

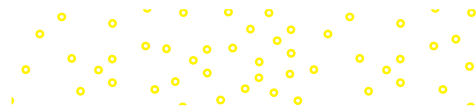
Tenth Edition

The **PHYSICS**  
of Everyday Phenomena  
A Conceptual Introduction to Physics

Mc  
Graw  
Hill

W. Thomas Griffith

Juliet W. Brosing



Tenth Edition

# The Physics of Everyday Phenomena

A Conceptual Introduction to Physics

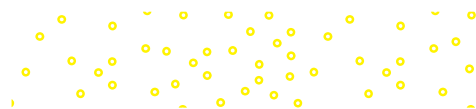
**W. Thomas Griffith**

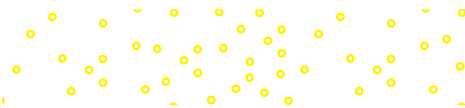
Pacific University

**Juliet W. Brosing**

Pacific University

**Mc  
Graw  
Hill**





THE PHYSICS OF EVERYDAY PHENOMENA: A CONCEPTUAL INTRODUCTION TO PHYSICS,  
TENTH EDITION

Published by McGraw Hill LLC, 1325 Avenue of the Americas, New York, NY 10121. Copyright ©2022 by McGraw Hill LLC. All rights reserved. Printed in the United States of America. Previous editions ©2019, 2015, and 2012. No part of this publication may be reproduced or distributed in any form or by any means, or stored in a database or retrieval system, without the prior written consent of McGraw Hill LLC, including, but not limited to, in any network or other electronic storage or transmission, or broadcast for distance learning.

Some ancillaries, including electronic and print components, may not be available to customers outside the United States.

This book is printed on acid-free paper.

1 2 3 4 5 6 7 8 9 LWI 24 23 22 21

ISBN 978-1-260-71893-5 (bound edition)

MHID 1-260-71893-X (bound edition)

ISBN 978-1-264-12121-2 (loose-leaf edition)

MHID 1-264-12121-0 (loose-leaf edition)

Portfolio Manager: *Beth Bettcher*

Senior Product Developer: *Mary Hurley*

Senior Marketing Manager: *Shannon O'Donnell*

Content Project Managers: *Jane Mohr and Samantha Donisi*

Buyer: *Susan K. Culbertson*

Designer: *Beth Blech*

Content Licensing Specialist: *Beth Cray*

Cover Image: *wangsong/123RF*

Compositor: *Aptara<sup>®</sup>, Inc.*

All credits appearing on page or at the end of the book are considered to be an extension of the copyright page.

**Library of Congress Cataloging-in-Publication Data**

Names: Griffith, W. Thomas, author. | Brosing, Juliet Wain, 1953- author.

Title: The physics of everyday phenomena : a conceptual introduction to physics / W. Thomas Griffith, Pacific University, Juliet W. Brosing, Pacific University.

Description: Tenth edition. | New York, NY : McGraw-Hill Education, [2022] | Includes index.

Identifiers: LCCN 2020021788 (print) | LCCN 2020021789 (ebook) | ISBN 9781260718935 (hardcover) | ISBN 9781264121212 (spiral bound) | ISBN 9781264121250 (ebook) | ISBN 9781264121267 (ebook other)

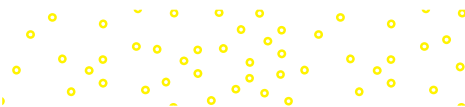
Subjects: LCSH: Physics—Textbooks.

Classification: LCC QC23.2 .G75 2022 (print) | LCC QC23.2 (ebook) | DDC 530—dc23

LC record available at <https://lccn.loc.gov/2020021788>

LC ebook record available at <https://lccn.loc.gov/2020021789>

The Internet addresses listed in the text were accurate at the time of publication. The inclusion of a website does not indicate an endorsement by the authors or McGraw Hill LLC, and McGraw Hill LLC does not guarantee the accuracy of the information presented at these sites.





# Brief Contents

---

<b>1</b>	Physics, the Fundamental Science	1
----------	----------------------------------	---

---

<b>Unit One</b>	The Newtonian Revolution	17
<b>2</b>	Describing Motion	18
<b>3</b>	Falling Objects and Projectile Motion	38
<b>4</b>	Newton's Laws: Explaining Motion	59
<b>5</b>	Circular Motion, the Planets, and Gravity	80
<b>6</b>	Energy and Oscillations	102
<b>7</b>	Momentum	124
<b>8</b>	Rotational Motion of Solid Objects	145

---

<b>Unit Two</b>	Fluids and Heat	169
<b>9</b>	The Behavior of Fluids	170
<b>10</b>	Temperature and Heat	192
<b>11</b>	Heat Engines and the Second Law of Thermodynamics	215

---

<b>Unit Three</b>	Electricity and Magnetism	237
<b>12</b>	Electrostatic Phenomena	238
<b>13</b>	Electric Circuits	260
<b>14</b>	Magnets and Electromagnetism	284

---

<b>Unit Four</b>	Wave Motion and Optics	307
<b>15</b>	Making Waves	308
<b>16</b>	Light Waves and Color	331
<b>17</b>	Light and Image Formation	354

---

<b>Unit Five</b>	The Atom and Its Nucleus	381
<b>18</b>	The Structure of the Atom	382
<b>19</b>	The Nucleus and Nuclear Energy	408

---

<b>Unit Six</b>	Relativity and Beyond	433
<b>20</b>	Relativity	434
<b>21</b>	Looking Deeper into Everyday Phenomena	457

---



# About the Authors

Tom Griffith is now Distinguished University Professor Emeritus at Pacific University in Forest Grove, Oregon, having retired after 36 years of teaching physics at Pacific. He still shows up on campus on occasion and might make a rare appearance with his guitar in a physics course. He now spends half of the year in Portland, Oregon, and his winters in Green Valley, Arizona. Over the years he has enjoyed hiking, bicycling, singing, and participating in musical comedies, and he still performs in a jam band in Arizona. During his years at Pacific, he served as Physics Department Chair, Natural Sciences Division Chair, Interim Dean of Enrollment Management, and Director of Institutional Research, among other things, but his primary focus was always teaching physics. He was active in the American Association of Physics Teachers (AAPT) and the Northwest Association for College Physics (PNACP). His wife of 42 years, Adelia, died of cancer in 2009. He married his wife Sally, an art photographer, in 2014 and they both enjoy exploring the western United States and more distant places.

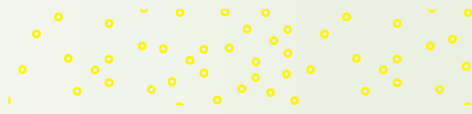


The author, Tom Griffith, and his wife, Sally.  
*Courtesy of Tom Griffith*

Juliet Brosing is now Distinguished University Professor Emeritus at Pacific University in Forest Grove, Oregon, where she taught physics for 30 years. Her research interests included nuclear physics, medical physics, and the application of teaching methods grounded in physics educational research. She has supported the importance of attracting young women into careers in science by helping to plan and run summer camps for seventh- and eighth-grade girls during the past 30 years. In 2012, she was named Oregon Professor of the Year by the Carnegie Foundation for the Advancement of Teaching and CASE (the Council for Advancement and Support of Education). She is the proud owner of three potato guns; parties with students at her house still involve projectiles, lots of noise, and fudge. Even though retired, Dr. Brosing retains contact with her many talented alumni. She now finds time for kayaking, gardening, and, of course, working on this book! Above all, Dr. Brosing is dedicated to helping faculty teach physics with a positive outlook and methods that encourage and benefit students, regardless of their chosen field of study.



The author, Juliet Brosing, and her husband, Keith LeComte, at the Oregon coast with their dog, Walter.  
*Karla Rumpf*



# Detailed Contents

Preface x  
Acknowledgments xv  
Secrets to Success in Studying Physics xviii

## 1 Physics, the Fundamental Science 1

- 1.1 What about Energy? 2
- 1.2 The Scientific Enterprise 5
  - Everyday Phenomenon Box 1.1**
  - The Case of the Malfunctioning Coffeemaker 7**
- 1.3 The Scope of Physics 8
- 1.4 The Role of Measurement and Mathematics in Physics 10
- 1.5 Physics and Everyday Phenomena 12
  - Everyday Phenomenon Box 1.2**
  - Scaling a Recipe 11**

*Summary 13, Key Terms 14, Conceptual Questions 14, Exercises 15, Synthesis Problems 16, Home Experiments and Observations 16*

## Unit One The Newtonian Revolution 17

## 2 Describing Motion 18

- 2.1 Average and Instantaneous Speed 19
  - Everyday Phenomenon Box 2.1**
  - Transitions in Traffic Flow 22**
- 2.2 Velocity 23
- 2.3 Acceleration 24
- 2.4 Graphing Motion 27
  - Everyday Phenomenon Box 2.2**
  - The 100-m Dash 30**
- 2.5 Uniform Acceleration 31

*Summary 33, Key Terms 33, Conceptual Questions 34, Exercises 36, Synthesis Problems 36, Home Experiments and Observations 37*

## 3 Falling Objects and Projectile Motion 38

- 3.1 Acceleration Due to Gravity 39
- 3.2 Tracking a Falling Object 42
  - Everyday Phenomenon Box 3.1**
  - Reaction Time 44**
- 3.3 Beyond Free Fall: Throwing a Ball Upward 46
- 3.4 Projectile Motion 48
- 3.5 Hitting a Target 50
  - Everyday Phenomenon Box 3.2**
  - Shooting a Basketball 52**

*Summary 54, Key Terms 55, Conceptual Questions 55, Exercises 57, Synthesis Problems 57, Home Experiments and Observations 58*

## 4 Newton's Laws: Explaining Motion 59

- 4.1 A Brief History 60
- 4.2 Newton's First and Second Laws 62
  - Everyday Phenomenon Box 4.1**
  - The Tablecloth Trick 65**
- 4.3 Mass and Weight 66
- 4.4 Newton's Third Law 68
  - Everyday Phenomenon Box 4.2**
  - Riding an Elevator 70**

- 4.5 Applications of Newton's Laws 71

*Summary 74, Key Terms 75, Conceptual Questions 75, Exercises 77, Synthesis Problems 78, Home Experiments and Observations 79*

## 5 Circular Motion, the Planets, and Gravity 80

- 5.1 Centripetal Acceleration 81
- 5.2 Centripetal Forces 84
  - Everyday Phenomenon Box 5.1**
  - Seat Belts, Air Bags, and Accident Dynamics 86**

- 5.3 Planetary Motion 87
- 5.4 Newton's Law of Universal Gravitation 91
- 5.5 The Moon and Other Satellites 94

**Everyday Phenomenon Box 5.2**  
**Explaining the Tides 96**

*Summary 97, Key Terms 98, Conceptual Questions 98, Exercises 99, Synthesis Problems 100, Home Experiments and Observations 101*

## 6 Energy and Oscillations 102

- 6.1 Simple Machines, Work, and Power 103
- 6.2 Kinetic Energy 106
- 6.3 Potential Energy 108
- 6.4 Conservation of Energy 110
  - Everyday Phenomenon Box 6.1**
  - Conservation of Energy 112**
  - Everyday Phenomenon Box 6.2**
  - Energy and the Pole Vault 114**
- 6.5 Springs and Simple Harmonic Motion 115

*Summary 118, Key Terms 119, Conceptual Questions 119, Exercises 121, Synthesis Problems 122, Home Experiments and Observations 123*

## 7 Momentum 124

- 7.1 Momentum and Impulse 125
- 7.2 Conservation of Momentum 128
  - Everyday Phenomenon Box 7.1**
  - The Egg Toss 129**
- 7.3 Recoil 131
- 7.4 Elastic and Inelastic Collisions 133
- 7.5 Collisions at an Angle 135
  - Everyday Phenomenon Box 7.2**
  - An Automobile Collision 137**

*Summary 139, Key Terms 140, Conceptual Questions 140, Exercises 142, Synthesis Problems 143, Home Experiments and Observations 144*

## 8 Rotational Motion of Solid Objects 145

- 8.1 What Is Rotational Motion? 146
- 8.2 Torque and Balance 149
- 8.3 Rotational Inertia and Newton's Second Law 152
- 8.4 Conservation of Angular Momentum 155
- 8.5 Riding a Bicycle and Other Amazing Feats 158

**Everyday Phenomenon Box 8.1**  
**Achieving the State of Yo 159**  
**Everyday Phenomenon Box 8.2**  
**Bicycle Gears 162**

*Summary 163, Key Terms 163, Conceptual Questions 164, Exercises 165, Synthesis Problems 166, Home Experiments and Observations 167*

---

## Unit Two Fluids and Heat 169

### 9 The Behavior of Fluids 170

- 9.1 Pressure and Pascal's Principle 171
- 9.2 Atmospheric Pressure and the Behavior of Gases 173
  - Everyday Phenomenon Box 9.1**
  - Measuring Blood Pressure 175**
- 9.3 Archimedes' Principle 178
- 9.4 Fluids in Motion 181
- 9.5 Bernoulli's Principle 184
  - Everyday Phenomenon Box 9.2**
  - Throwing a Curveball 187**

*Summary 188, Key Terms 189, Conceptual Questions 189, Exercises 190, Synthesis Problems 191, Home Experiments and Observations 191*

### 10 Temperature and Heat 192

- 10.1 Temperature and Its Measurement 193
- 10.2 Heat and Specific Heat Capacity 196
  - Everyday Phenomenon Box 10.1**
  - Heat Packs 200**
- 10.3 Joule's Experiment and the First Law of Thermodynamics 201
- 10.4 Gas Behavior and the First Law 203
- 10.5 The Flow of Heat 206
  - Everyday Phenomenon Box 10.2**
  - Solar Collectors, Greenhouses, and Global Warming 209**

*Summary 210, Key Terms 210, Conceptual Questions 211, Exercises 212, Synthesis Problems 213, Home Experiments and Observations 214*

# 11 Heat Engines and the Second Law of Thermodynamics 215

- 11.1 Heat Engines 216
  - Everyday Phenomenon Box 11.1**
  - Hybrid Automobile Engines 218**
- 11.2 The Second Law of Thermodynamics 220
- 11.3 Refrigerators, Heat Pumps, and Entropy 222
- 11.4 Thermal Power Plants and Energy Resources 225
- 11.5 Perpetual Motion and Energy Frauds 228
  - Everyday Phenomenon Box 11.2**
  - A Productive Pond 230**

*Summary 231, Key Terms 232, Conceptual Questions 232, Exercises 234, Synthesis Problems 234, Home Experiments and Observations 235*

---

## Unit Three Electricity and Magnetism 237

# 12 Electrostatic Phenomena 238

- 12.1 Effects of Electric Charge 239
- 12.2 Conductors and Insulators 242
- 12.3 The Electrostatic Force: Coulomb's Law 244
  - Everyday Phenomenon Box 12.1**
  - Cleaning Up the Smoke 245**
- 12.4 The Electric Field 248
- 12.5 Electric Potential 251
  - Everyday Phenomenon Box 12.2**
  - Lightning 254**

*Summary 255, Key Terms 256, Conceptual Questions 256, Exercises 258, Synthesis Problems 258, Home Experiments and Observations 259*

# 13 Electric Circuits 260

- 13.1 Electric Circuits and Electric Current 261
  - Everyday Phenomenon Box 13.1**
  - Electrical Impulses in Nerve Cells 264**

- 13.2 Ohm's Law and Resistance 266
- 13.3 Series and Parallel Circuits 268
- 13.4 Electric Energy and Power 272
- 13.5 Alternating Current and Household Circuits 274
  - Everyday Phenomenon Box 13.2**
  - The Hidden Switch in Your Toaster 275**

*Summary 278, Key Terms 279, Conceptual Questions 279, Exercises 281, Synthesis Problems 282, Home Experiments and Observations 283*

# 14 Magnets and Electromagnetism 284

- 14.1 Magnets and the Magnetic Force 285
- 14.2 Magnetic Effects of Electric Currents 288
- 14.3 Magnetic Effects of Current Loops 291
  - Everyday Phenomenon Box 14.1**
  - Direct-Current Motors 294**
- 14.4 Faraday's Law: Electromagnetic Induction 295
  - Everyday Phenomenon Box 14.2**
  - Vehicle Sensors at Traffic Lights 298**

*14.5 Generators and Transformers 299*  
*Summary 302, Key Terms 303, Conceptual Questions 303, Exercises 304, Synthesis Problems 305, Home Experiments and Observations 306*

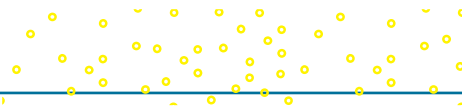
---

## Unit Four Wave Motion and Optics 307

# 15 Making Waves 308

- 15.1 Wave Pulses and Periodic Waves 309
  - Everyday Phenomenon Box 15.1**
  - Electric Power from Waves 310**
- 15.2 Waves on a Rope 313
- 15.3 Interference and Standing Waves 315
- 15.4 Sound Waves 319
  - Everyday Phenomenon Box 15.2**
  - A Moving Car Horn and the Doppler Effect 321**





**15.5** The Physics of Music 322  
*Summary 326, Key Terms 327, Conceptual Questions 327, Exercises 329, Synthesis Problems 329, Home Experiments and Observations 330*

## 16 Light Waves and Color 331

**16.1** Electromagnetic Waves 332  
**16.2** Wavelength and Color 336  
**16.3** Interference of Light Waves 338  
**Everyday Phenomenon Box 16.1**  
**Why Is the Sky Blue? 339**  
**Everyday Phenomenon Box 16.2**  
**Antireflection Coatings on Eyeglasses 343**  
**16.4** Diffraction and Gratings 343  
**16.5** Polarized Light 346  
*Summary 349, Key Terms 350, Conceptual Questions 350, Exercises 351, Synthesis Problems 352, Home Experiments and Observations 353*

## 17 Light and Image Formation 354

**17.1** Reflection and Image Formation 355  
**17.2** Refraction of Light 358  
**Everyday Phenomenon Box 17.1**  
**Rainbows 362**  
**17.3** Lenses and Image Formation 362  
**17.4** Focusing Light with Curved Mirrors 366  
**17.5** Eyeglasses, Microscopes, and Telescopes 369  
**Everyday Phenomenon Box 17.2**  
**Laser Refractive Surgery 372**  
*Summary 375, Key Terms 376, Conceptual Questions 376, Exercises 377, Synthesis Problems 378, Home Experiments and Observations 379*

## Unit Five The Atom and Its Nucleus 381

### 18 The Structure of the Atom 382

**18.1** The Existence of Atoms: Evidence from Chemistry 383  
**Everyday Phenomenon Box 18.1**  
**Fuel Cells and the Hydrogen Economy 386**

**18.2** Cathode Rays, Electrons, and X-rays 389  
**Everyday Phenomenon Box 18.2**  
**Television Development 390**

**18.3** Radioactivity and the Discovery of the Nucleus 393

**18.4** Atomic Spectra and the Bohr Model of the Atom 396

**18.5** Particle Waves and Quantum Mechanics 400

*Summary 404, Key Terms 404, Conceptual Questions 405, Exercises 406, Synthesis Problems 406, Home Experiments and Observations 407*

## 19 The Nucleus and Nuclear Energy 408

**19.1** The Structure of the Nucleus 409

**19.2** Radioactive Decay 412

**Everyday Phenomenon Box 19.1**  
**Smoke Detectors 414**

**19.3** Nuclear Reactions and Nuclear Fission 417

**19.4** Nuclear Reactors 420

**Everyday Phenomenon Box 19.2**  
**What Happened at Fukushima? 424**

**19.5** Nuclear Weapons and Nuclear Fusion 425

*Summary 428, Key Terms 429, Conceptual Questions 429, Exercises 430, Synthesis Problems 431, Home Experiments and Observations 431*

## Unit Six Relativity and Beyond 433

### 20 Relativity 434

**20.1** Relative Motion in Classical Physics 435

**20.2** The Speed of Light and Einstein's Postulates 438

**20.3** Time Dilation and Length Contraction 442

**20.4** Newton's Laws and Mass-Energy Equivalence 445

**Everyday Phenomenon Box 20.1**  
**The Twin Paradox 446**

# 21

## Looking Deeper into Everyday Phenomena 457

### 20.5 General Relativity 449

*Summary 453, Key Terms 454,  
Conceptual Questions 454,  
Exercises 455, Synthesis Problems 455,  
Home Experiments and Observations 456*

### 21.1 Quarks and Other

*Elementary Particles 458*

### 21.2 Cosmology: Looking Out into the Universe 461

### 21.3 Semiconductors

*and Microelectronics 464*

### 21.4 Superconductors

*and Other New Materials 468*

#### **Everyday Phenomenon Box 21.1**

#### **Holograms 471**

*Summary 473, Key Terms 473, Conceptual  
Questions 474, Exercises 474, Synthesis  
Problems 474, Home Experiments and  
Observations 475*

## Appendix A

Using Simple Algebra A-1

## Appendix B

Decimal Fractions, Percentages,  
and Scientific Notation A-3

## Appendix C

Vectors and Vector Addition A-7

## Appendix D

Answers to Selected Questions, Exercises, and  
Synthesis Problems A-11

## Appendix E

Conversion Factors and Periodic Table of the  
Elements A-19

Glossary G-1

Index I-1

# Preface

**T**he satisfaction of understanding how rainbows are formed, how ice skaters spin, or why ocean tides roll in and out—phenomena that we have all seen or experienced—is one of the best motivators available for building scientific literacy. This book attempts to make that sense of satisfaction accessible to non-science majors. Intended for use in a one-semester or two-quarter course in conceptual physics, this book is written in a narrative style, frequently using questions designed to draw the reader into a dialogue about the ideas of physics. This inclusive style allows the book to be used by anyone interested in exploring the nature of physics and explanations of everyday physical phenomena.

---

*“The origin of the book came from an effort to write usable conceptual questions. The concepts are what we hope non-science majors will carry with them. Quantitative exercises have their place, but should be subordinate to the concepts.”*

—W. Thomas Griffith, author

---

## How This Book Is Organized

The organization of chapters is traditional, with some minor variations. The chapter on energy (chapter 6) appears prior to that on momentum (chapter 7), so that energy ideas can be used in the discussion of collisions. Wave motion is found in chapter 15, following electricity and magnetism and prior to chapters 16 and 17 on optics. The chapter on fluids (chapter 9) follows mechanics and leads into the chapters on thermodynamics. The first 17 chapters are designed to introduce students to the major ideas of classical physics and can be covered in a one-semester course with some judicious paring.

The complete 21 chapters could easily support a two-quarter course, and even a two-semester course in which the ideas are treated thoroughly and carefully. Chapters 18 and 19, on atomic and nuclear phenomena, are considered essential by many instructors, even in a one-semester course. If included in such a course, we recommend curtailing

coverage in other areas to avoid student overload. Sample syllabi for these different types of courses can be found on the instructor’s website.

Some instructors would prefer to put chapter 20 on relativity at the end of the mechanics section or just prior to the modern physics material. Relativity has little to do with everyday phenomena, of course, but is included because of the high interest that it generally holds for students. The final chapter (21) introduces a variety of topics in modern physics—including particle physics, cosmology, semiconductors, and superconductivity—that could be used to stimulate interest at various points in a course.

One plea to instructors, as well as to students using this book: Don’t try to cram too much material into too short a time! We have worked diligently to keep this book to a reasonable length while still covering the core concepts usually found in an introduction to physics. These ideas are most enjoyable when enough time is spent in lively discussion and in consideration of questions, so that a real understanding develops. Trying to cover material too quickly defeats the conceptual learning and leaves students in a dense haze of words and definitions. Less can be more if a good understanding results.

## Mathematics in a Conceptual Physics Course

The use of mathematics in a physics course is a formidable block for many students, particularly non-science majors. Although there have been attempts to teach conceptual physics without any mathematics, these attempts miss an opportunity to help students gain confidence in using and manipulating simple quantitative relationships.

Clearly, mathematics is a powerful tool for expressing the quantitative relationships of physics. The use of mathematics can be carefully limited, however, and subordinated to the physical concepts being addressed. Many users of the first edition of this text felt that mathematical expressions appeared too frequently for the comfort of some students. In response, we substantially reduced the use of mathematics in the body of the text in the second edition. Most users have indicated that the current level is about right, so we have not changed the mathematics level in subsequent editions.

Logical coherence is a strong feature of this book. Formulas are introduced carefully after conceptual arguments are provided, and statements in words of these relationships generally accompany their introduction. We have continued to fine tune the example boxes that present sample exercises and questions. Most of these provide simple numerical illustrations of the ideas discussed. No mathematics prerequisite beyond high school algebra should be necessary. A discussion of the basic ideas of very simple algebra is found in appendix A, together with some practice exercises, for students who need help with these ideas.

## New to This Edition

Building on the existing strengths of the *Physics of Everyday Phenomena* text, we have made additions to our offerings based on reviewer feedback. The most significant changes in this edition have come with the digital enhancements.

- We have added to our Connect® offerings by incorporating the concept videos, narrated by one of the authors, into the Connect question bank. These videos explain how physics is involved in everyday situations, so question content has likewise been authored and enhanced to showcase the everyday application of physics. The Instructor's Manual for each chapter also lists the specific section of the text each video corresponds to, and the videos are then hyperlinked in the eBook and noted in the print text with an icon. These additional guides will help faculty, should they wish to use the videos during class. Each video is no more than 5 minutes long.
- We have developed additional conceptual questions and exercises and made them available as Connect online homework.
- The Instructor's Manual, downloadable from the instructor resources in Connect, has also been improved and describes which PowerPoint slides and which clicker questions go with each section of the text, making it easier for an instructor to prepare for an engaged class period with a minimum of effort. Within the Instructor's Manual, instructors will also find suggestions for demonstrations and discussions.
- For maximum flexibility, the test bank is available in both the Connect question bank and Test Builder. Found in Connect under the Library Tab, Test Builder is a cloud-based tool that enables instructors to format tests that can be printed or administered within a Learning Management System.

In addition to the enhanced digital offerings, we have continued to improve upon the text with the 10th edition. As the book has evolved, we have tried to remain faithful to the principles that have guided the writing of the book from the outset. One of these has been to keep the book to a manageable length, in both the number of chapters and the overall content.

We have revised and updated the end-of-chapter material in the text and added some new conceptual questions and exercises. All odd-numbered exercises have the answers in

appendix D in the hard copy of the text, as well as links to the answers in the e-book. Answers to about one-sixth of the conceptual questions are also included in appendix D. Answers to a different one-sixth of the conceptual questions are included as a Student Resource on the Connect instructor resources and may be provided to students at the instructor's discretion. We encourage users to adopt the digital homework system, Connect. The value of this is that parameters in the exercises have been randomized for students. Thus, students spend time discussing *how* to solve the problems, rather than simply focusing on the answer. We have found this to be very powerful pedagogically. We have worked hard to reword the conceptual questions as multiple choice offerings in Connect—a significant tool to enhance conceptual understanding.

The everyday phenomenon boxes have been praised by many users. We have updated several of these boxes, particularly those in chapters 10 and 18, and have added a new one in chapter 1 (on dealing with proportions). In addition to these specific changes, we have also revised the text in many places to enhance understanding of some of the more difficult concepts.

**Building an Energy Emphasis.** Although this book remains a basic conceptual physics text, we are working to make the book better serve instructors who want to teach a conceptual physics course with an energy emphasis. A syllabus for instructors wishing to teach a course with an energy emphasis can be found in the Connect instructor resources. We plan to continue building this emphasis in future editions.

**Continued Refinements in Artwork and Textual Clarity.** Although the textual clarity of this text has been extensively praised by many reviewers and users, it can always be improved. Reviewers continue to point out places where either the art or the text can be improved, and we have responded to many of these suggestions. To this end, we have made many changes, often subtle, to both the art and the text.

## Digital Learning Tools

### Connect

McGraw-Hill Connect® is a highly reliable, easy-to-use homework and learning management solution that utilizes learning science and award winning adaptive tools to improve student results.

### Homework and Adaptive Learning

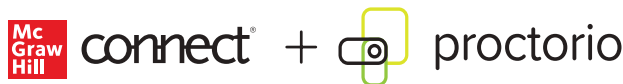
- Connect's assignments help students contextualize what they've learned through application, so they can better understand the material and think critically.
- Connect will create a personalized study path customized to individual student needs through SmartBook®.
- SmartBook helps students study more efficiently by delivering an interactive reading experience through adaptive highlighting and review.

**Robust Analytics and Reporting**

Connect Insight<sup>®</sup> generates easy-to-read reports on individual students, the class as a whole, and specific assignments.

- The Connect Insight dashboard delivers data on performance, study behavior, and effort. Instructors can quickly identify students who struggle and focus on material that the class has yet to master.
- Connect automatically grades assignments and quizzes, providing easy-to-read reports on individual and class performance.

**Remote Proctoring & Browser-Locking Capabilities**



New remote proctoring and browser-locking capabilities, hosted by Proctorio within Connect, provide control of the assessment environment by enabling security options and verifying the identity of the student.

Seamlessly integrated within Connect, these services allow instructors to control students' assessment experience by restricting browser activity, recording students' activity, and verifying students are doing their own work.

Instant and detailed reporting gives instructors an at-a-glance view of potential academic integrity concerns, thereby avoiding personal bias and supporting evidence-based claims.

**Trusted Service and Support**

Connect integrates with your Learning Management System (LMS) to provide single sign-on and automatic syncing of grades. Integration with Blackboard<sup>®</sup>, D2L<sup>®</sup>, Moodle, and Canvas also provides automatic syncing of the course calendar and assignment-level linking.

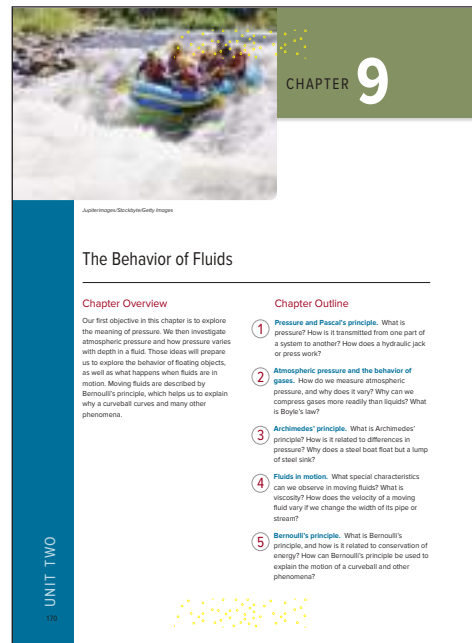
- Connect offers comprehensive service, support, and training throughout every phase of your implementation.
- If you're looking for some guidance on how to use Connect, or want to learn tips and tricks from super users, you can find tutorials as you work. Our Digital Faculty Consultants and Student Ambassadors offer insight into how to achieve the results you want with Connect.

**Learning Aids**

The overriding theme of this book is to introduce physical concepts by appealing to everyday phenomena whenever possible. To achieve this goal, this text includes a variety of features to make the study of *The Physics of Everyday Phenomena* more effective and enjoyable. A few key concepts form the basis for understanding physics, and the textual features described here reinforce this structure, so that the reader will not be lost in a flurry of definitions and formulas.

**Chapter Openers**

Each chapter begins with an illustration from everyday experience and then proceeds to use it as a theme for introducing relevant physical concepts. Physics can seem abstract to many students, but using everyday phenomena and concrete



examples reduces that abstractness. The chapter **overview** previews the chapter's contents and what students can expect to learn from reading the chapter. The overview introduces the concepts to be covered, facilitating the integration of topics and helping students to stay focused and organized while reading the chapter for the first time. The chapter **outline** includes all the major topic headings within the body of the chapter. It also contains questions that provide students with a guide of what they will be expected to know in order to comprehend the major concepts of the chapter. (These questions are then correlated to the end-of-chapter summaries.)

The chapter outlines, questions, and summaries provide a clear framework for the ideas discussed in each chapter. One of the difficulties that students have in learning physics (or any subject) is that they fail to construct the big picture of how things fit together. A consistent chapter framework can be a powerful tool in helping students see how ideas mesh.

**Other Text Features**

**Running summary paragraphs** are found at the end of each chapter section to supplement the more general summary at the end of the chapter.

Light rays are bent when they pass from one transparent substance to another, because the speed of light changes at the boundary between the two substances. The law of refraction describes how much bending occurs and whether the bending is toward or away from the surface normal. Because of this bending, the image of an underwater object appears to lie closer to the surface of the water than the actual position of the object. For light traveling initially inside glass or water, there is a critical angle of incidence beyond which the light is totally reflected rather than being refracted. The index of refraction varies with wavelength, producing the dispersion of colors we see when light passes through a prism.

**Subsection headings** are often cast in the form of questions to motivate the reader and pique curiosity.

### What happens to the gas in a hot-air balloon?

When the gas is heated in a hot-air balloon (fig. 10.17), the pressure, not the temperature, remains constant. The pressure of the gas inside the balloon cannot be significantly larger than that of the surrounding atmosphere. When pressure remains constant in a process, it is called **isobaric** (*baric* refers to pressure). The internal energy increases as the gas is heated, and so does the temperature. The gas also expands in this process, however, which removes some internal energy.

The gas expands in the isobaric heating process because of another property of ideal gases discovered near the beginning of the nineteenth century. A series of experiments showed that

**Everyday phenomenon boxes** relate physical concepts discussed in the text to real-world topics, societal issues, and modern technology, underscoring the relevance of physics and how it relates to our day-to-day lives. The list of topics includes

- The Case of the Malfunctioning Coffeemaker (chapter 1)
- Scaling a Recipe (chapter 1)
- Transitions in Traffic Flow (chapter 2)
- The 100-m Dash (chapter 2)
- Reaction Time (chapter 3)
- Shooting a Basketball (chapter 3)
- The Tablecloth Trick (chapter 4)
- Riding an Elevator (chapter 4)
- Seat Belts, Air Bags, and Accident Dynamics (chapter 5)
- Explaining the Tides (chapter 5)
- Conservation of Energy (chapter 6)
- Energy and the Pole Vault (chapter 6)
- The Egg Toss (chapter 7)
- An Automobile Collision (chapter 7)
- Achieving the State of Yo (chapter 8)
- Bicycle Gears (chapter 8)
- Measuring Blood Pressure (chapter 9)
- Throwing a Curveball (chapter 9)
- Heat Packs (chapter 10)
- Solar Collectors, Greenhouses, and Global Warming (chapter 10)
- Hybrid Automobile Engines (chapter 11)
- A Productive Pond (chapter 11)
- Cleaning Up the Smoke (chapter 12)
- Lightning (chapter 12)
- Electrical Impulses in Nerve Cells (chapter 13)
- The Hidden Switch in Your Toaster (chapter 13)
- Direct-Current Motors (chapter 14)
- Vehicle Sensors at Traffic Lights (chapter 14)
- Electric Power from Waves (chapter 15)

- A Moving Car Horn and the Doppler Effect (chapter 15)
- Why Is the Sky Blue? (chapter 16)
- Antireflection Coatings on Eyeglasses (chapter 16)
- Rainbows (chapter 17)
- Laser Refractive Surgery (chapter 17)
- Fuel Cells and the Hydrogen Economy (chapter 18)
- Television Development (chapter 18)
- Smoke Detectors (chapter 19)
- What Happened at Fukushima? (chapter 19)
- The Twin Paradox (chapter 20)
- Holograms (chapter 21)

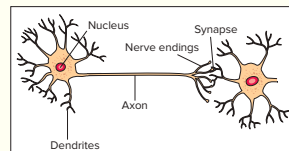
### Everyday Phenomenon Box 13.1

#### Electrical Impulses in Nerve Cells

**The Situation.** If you make a conscious decision to wiggle your big toe, the big toe will quickly wiggle. Somehow, a signal passes from your brain to the muscles in the toe, causing the muscles to contract. That process happens quickly—there is not much delay between the decision and the toe wiggle.

How does the wiggle command get from your brain to your toe? Does the signal travel over a biological wire or cable of some kind? Is a flow of electric charge involved similar to what happens in the wires of a landline telephone? We know that nerve cells are involved, but how do they work?

**The Analysis.** The study of electrical effects in nerve cells goes back to the work of Galvani and Volta on “animal electricity” that led to the invention of the battery. It was clear even then that an electrical process is involved. However, this process is much more complicated than the simple flow of charge in a wire.



A neuron has a long extension called an axon, which is often much longer relative to the rest of the cell than shown here. The nerve endings may contact dendrites of other cells in synapses.

The signal is transmitted through nerve cells (or *neurons*) like the one pictured in the first drawing. Like any biological cell, the main body of the neuron contains a nucleus and has a number of *dendrites* that can receive signals from other cells. Unlike most other cells, though, neurons have a long, tail-like segment called an *axon* that emerges from the main cell body. The axons can be as long as a meter or more, starting perhaps in the spinal cord and terminating in your foot or hand. At the end of the axon are a number of thinner filaments, or *nerve endings*, that may contact the dendrites of other cells in junctions called *synapses*.

Just as in a phone system, the signal that is transmitted involves a change in voltage. The change in voltage along the axon of a nerve cell is transmitted very differently than that in a metal wire, however. In fact, the primary flow of charge in a nerve cell occurs perpendicularly to the axon rather than along its length. To understand this, we need to take a closer look at the structure of the axon.

Any cell has a *membrane* that is essentially the outer covering of the cell that holds everything together. The membrane of an axon has some unusual properties. It maintains a balance between certain chemical ions (charged atoms) on the inside and outside surfaces of the membrane. In its normal (resting) state, positively charged sodium ions ( $\text{Na}^+$ ) are excluded from the inside of the cell. There is a small excess of positively charged ions (mostly potassium,  $\text{K}^+$ ) on the outside surface of the membrane and of negatively charged ions (mostly chlorine,  $\text{Cl}^-$ ) on the inside surface. This creates a voltage difference between the inside and outside surfaces of the axon. If we describe this difference as  $\Delta V = V_{\text{inside}} - V_{\text{outside}}$ , it is typically about  $-70 \text{ mV}$ .

**Study hints** and **study suggestions** provide students with pointers on their use of the textbook, tips on applying the principles of physical concepts, and suggestions for home experiments.

### Study Hint

If you have the materials handy, you should try the battery-and-bulb experiment before reading further. The delight of figuring out how to get the bulb to light is something not to be spoiled by reading on prematurely. Once you get it to light (without killing the battery), you may wish to experiment with other configurations and try to understand what distinguishes working arrangements from nonworking ones. Experimenting will help to make the concept of a circuit more vivid.

**Example boxes** are included within the chapter and contain one or more concrete, worked examples of a problem and its solution as it applies to the topic at hand. Through careful

study of these examples, students can better appreciate the many uses of problem solving in physics.

### Example Box 2.4

#### Sample Exercise: Uniform Acceleration

A car traveling due east with an initial velocity of 10 m/s accelerates for 6 seconds at a constant rate of 4 m/s<sup>2</sup>.

- What is its velocity at the end of this time?
- How far does it travel during this time?

a.  $v_0 = 10 \text{ m/s}$                        $v = v_0 + at$   
 $a = 4 \text{ m/s}^2$                            $= 10 \text{ m/s} + (4 \text{ m/s}^2)(6 \text{ s})$   
 $t = 6 \text{ s}$                                    $= 10 \text{ m/s} + 24 \text{ m/s}$   
 $v = ?$                                        $= \mathbf{34 \text{ m/s}}$

$v = 34 \text{ m/s due east}$

b.  $d = v_0t + \frac{1}{2}at^2$   
 $= (10 \text{ m/s})(6 \text{ s}) + \frac{1}{2}(4 \text{ m/s}^2)(6 \text{ s})^2$   
 $= 60 \text{ m} + (2 \text{ m/s}^2)(36 \text{ s}^2)$   
 $= 60 \text{ m} + 72 \text{ m} = \mathbf{132 \text{ m}}$

**Debatable Issues** provide open-ended, opinion questions on—but not limited to—energy and environmental issues to be used as class discussion, as writing assignments, and/or for Internet forums. Notes on discussion ideas and results are included in the instructor’s manual.

### Debatable Issue

France gets more than 75% of its power from nuclear energy and claims a substantial level of energy independence and almost the lowest-cost electricity in Europe. It also has an extremely low level of CO<sub>2</sub> emissions per capita from electricity generation. Why is nuclear power not used more extensively in other European countries or in the United States?

### End-of-Chapter Features

- The **summary** highlights the key elements of the chapter and correlates to the questions asked about the chapter’s major concepts in the chapter opener.

- Key terms** are page-referenced to where students can find the terms defined in context.

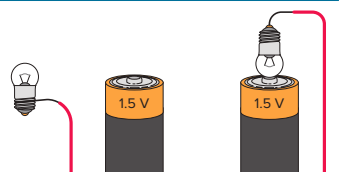
### Key Terms

### Conceptual Questions

#### Conceptual Questions

\* = more open-ended questions, requiring lengthier responses, suitable for group discussion  
**Q** = sample responses are available in appendix D  
**Q** = sample responses are available in Connect

Q1. Two arrangements of a battery, bulb, and wire are shown in the diagram. Which of the two arrangements, if either, will light the bulb? Explain.



#### Exercises

For the exercises in this chapter (and subsequent chapters), use the more accurate value of  $g = 9.8 \text{ m/s}^2$  for the acceleration due to gravity.

E1. A single force of 42 N acts upon a 6-kg block. What is the magnitude of the acceleration of the block?

E2. A heavy ball is moving at a rate of 10 m/s upon the floor.

E6. A 5-kg block being pushed across a table by an acceleration of 6.0 m/s<sup>2</sup>.

- What is the net force acting upon the block?
- If the magnitude of  $\mathbf{P}$  is 38 N, what is the magnitude of the frictional force acting upon the block?

#### Synthesis Problems

SP1. Two long, parallel wires carry currents of 8 A and 12 A in opposite directions, as shown in the diagram. The distance between the wires is 4 cm.

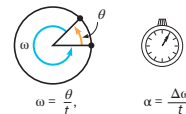
- What is the magnitude of the force per unit length exerted by one wire on the other?
- What are the directions of the forces on each wire?
- What is the total force exerted on a 30-cm length of the

- What is the direction of the magnetic field at the position shown in the diagram?
- Will this force change the magnitude of the ball’s velocity? Explain.
- From Newton’s second law, what is the acceleration of the charged ball?
- Because centripetal acceleration is directed toward the center of the circular path, what is the radius of the path?

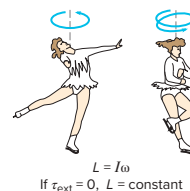
### Summary

We have considered the rotational motion of a solid object and what causes changes in rotational motion. We have used an analogy between linear motion and rotational motion to develop many of the concepts. The key points are the following:

1 **What is rotational motion?** Rotational displacement is described by an angle. Rotational velocity is the rate of change of that angle with time. Rotational acceleration is the rate of change of rotational velocity with time.



4 **Conservation of angular momentum.** By analogy to linear momentum, angular momentum is defined as the rotational inertia times the rotational velocity. It is conserved when no net external torque acts on the system.



### Key Terms

Rotational velocity, 146	Fulcrum, 149	Moment of inertia, 153
Rotational displacement, 146	Torque, 150	Angular momentum, 156
Radian, 146	Lever arm, 150	Conservation of angular momentum, 156
Linear displacement, 146	Center of gravity, 151	Right-hand rule, 158
	Rotational inertia, 153	

- Conceptual Questions** are designed to challenge students to demonstrate their understanding of the key concepts. Selected answers are provided in appendix D to assist students with their study of more difficult concepts.

- Exercises and synthesis problems** are intended to help students test their grasp of problem solving. The odd-numbered exercises have answers in appendix D. By working through the odd-numbered exercises and checking the answers in appendix D, students can gain confidence in tackling

### Exercises

### Synthesis Problems

the even-numbered exercises and thus reinforce their problem-solving skills.

- Because many courses for non-science majors do not have a laboratory component, **home experiments and observations** are found at the end of each chapter. The spirit of these home experiments is to enable students to explore the behavior of physical phenomena using easily available rulers, string, paper clips, balls, toy cars, flashlight batteries, and so on. Many instructors have found them useful for putting students into the exploratory and observational frame of mind that is important to scientific thinking. This is certainly one of our objectives in developing scientific literacy.

---

*“Students and faculty alike will find the home experiments engaging. Physics is not a spectator sport and participation is key.”*

---

—Juliet W. Brosing, author


## Supplements

### Instructor Resources

In addition, instructor resources, accessed by the library tab in Connect, provide instructors with useful tools designed to help improve student understanding of the material presented in the text and class and other tools designed to help ease the time burdens of the course by providing valuable presentation and preparation tools.

Accessible PowerPoint Lectures  
 Instructor’s Manual  
 Sample Syllabi  
 Clicker Questions  
 PowerPoint and Image Files of Art and Photos from the Text  
 Test Bank  
 Formula Summaries  
 Physics Interactives  
 Concept Videos  
 Practice Problems

For sharing with students:

- Author-narrated videos illustrating physics in everyday situations (noted in text with a video icon) 
- Student Solutions Manual
- Additional Solutions and Answers

### Personal Response Systems

Personal Response Systems can bring interactivity into the classroom or lecture hall. Wireless response systems such as Poll Everywhere give the instructor and students immediate feedback from the entire class. Poll Everywhere allows

## Home Experiments and Observations

### Home Experiments and Observations

**H1E1.** The concept of half-life, and the associated exponential decay curve, can be made more vivid by using piles of pennies (or other stackable objects) to represent atoms.

- Collect as many pennies as you can find on dresser tops, in your own pockets, flip up one hundred about 1000 times.
- Divide your pile into two equal stacks, placed side by side. The left pile represents the original number of atoms.
- Divide the right pile in half. Place one of the resulting stacks next to the original left stack. This represents the number of atoms remaining after one half-life has passed.
- Continue this process, always dividing the remaining right stack in half and placing the stack obtained from

**H1E2.** The concept of a chain reaction can be made more vivid by using the same piles of pennies (or other objects) you used in H1E1. Gather about \$3.00 worth of pennies. Each pile will represent the number of neutrons produced in the chain reaction.

- Assume each fission creates 2 neutrons, as shown in Figure 19.13. On the first pile, put one penny to indicate the neutron that initiated the fission.
- 2 neutrons created in the fission. 2 pennies, to indicate the 2 neutrons created in the fission.
- On the next pile, put 2 × 3, or 6, pennies, given that each of the 2 neutrons produced in the first reaction will create 3 neutrons.
- How many pennies do you need in the next pile? And in subsequent piles?

students to use their computer, smartphone, tablet, or text message device to respond to questions. Instructors are able to motivate student preparation, interactivity, and active learning, receiving immediate feedback to gauge which concepts students understand. Questions covering the content of the *Physics of Everyday Phenomena* text are formatted in PowerPoint and are available on the Connect Instructor Resources for use with any personal response system.

## Computerized Test Banks Online

For maximum flexibility, the test bank is available in both the Connect question bank and Test Builder. Found in Connect under the Library Tab, Test Builder is a cloud-based tool that enables instructors to format tests that can be printed or administered within a Learning Management System.

## Acknowledgments

A large number of people have contributed to this 10th edition, either directly or indirectly. We extend particular thanks to those who participated in reviews of the previous editions. Their thoughtful suggestions have had a direct impact on the clarity and accuracy of this edition, even when it was not possible to fully incorporate all of their ideas due to space limitations or other constraints.

We also wish to acknowledge the contributions of the editorial staff and book team members at McGraw-Hill Higher Education. Their commitment of time and enthusiasm for this work has helped enormously in pushing this project forward. We also owe a huge debt of thanks to our colleagues at Pacific University for helpful suggestions as well as for their forbearance when this project limited our time for other activities. Our 10th edition accuracy checker, Michael Faux of SUNY Oneonta, also provided constructive criticisms and many suggestions for improvement.

Last, but certainly not least, we would both like to acknowledge the support of our families, friends, and colleagues. Their encouragement has been essential and has allowed us to enjoy the pleasure of this endeavor.





# connect<sup>®</sup>

## Instructors: Student Success Starts with You

### Tools to enhance your unique voice

Want to build your own course? No problem. Prefer to use our turnkey, prebuilt course? Easy. Want to make changes throughout the semester? Sure. And you'll save time with Connect's auto-grading too.

# 65%

Less Time Grading



Laptop: McGraw Hill; Woman/dog: George Doyle/Getty Images

### Study made personal

Incorporate adaptive study resources like SmartBook<sup>®</sup> 2.0 into your course and help your students be better prepared in less time. Learn more about the powerful personalized learning experience available in SmartBook 2.0 at [www.mheducation.com/highered/connect/smartbook](http://www.mheducation.com/highered/connect/smartbook)

### Affordable solutions, added value



Make technology work for you with LMS integration for single sign-on access, mobile access to the digital textbook, and reports to quickly show you how each of your students is doing. And with our Inclusive Access program you can provide all these tools at a discount to your students. Ask your McGraw Hill representative for more information.

Padlock: Jobalou/Getty Images

### Solutions for your challenges



A product isn't a solution. Real solutions are affordable, reliable, and come with training and ongoing support when you need it and how you want it. Visit [www.supportateverystep.com](http://www.supportateverystep.com) for videos and resources both you and your students can use throughout the semester.

Checkmark: Jobalou/Getty Images

**SUPPORT** AT  
*every step*

## Students: Get Learning that Fits You

### Effective tools for efficient studying

Connect is designed to make you more productive with simple, flexible, intuitive tools that maximize your study time and meet your individual learning needs. Get learning that works for you with Connect.

### Study anytime, anywhere

Download the free ReadAnywhere app and access your online eBook or SmartBook 2.0 assignments when it's convenient, even if you're offline. And since the app automatically syncs with your eBook and SmartBook 2.0 assignments in Connect, all of your work is available every time you open it. Find out more at [www.mheducation.com/readanywhere](http://www.mheducation.com/readanywhere)

*"I really liked this app—it made it easy to study when you don't have your textbook in front of you."*

- Jordan Cunningham,  
Eastern Washington University



Calendar: owattaphotos/Getty Images

### Everything you need in one place

Your Connect course has everything you need—whether reading on your digital eBook or completing assignments for class, Connect makes it easy to get your work done.

### Learning for everyone

McGraw Hill works directly with Accessibility Services Departments and faculty to meet the learning needs of all students. Please contact your Accessibility Services Office and ask them to email [accessibility@mheducation.com](mailto:accessibility@mheducation.com), or visit [www.mheducation.com/about/accessibility](http://www.mheducation.com/about/accessibility) for more information.

Top: Jenner Images/Getty Images, Left: Hero Images/Getty Images, Right: Hero Images/Getty Images



# Secrets to Success in Studying Physics

First of all, we should admit that there are no secrets. Conscientious work and follow-through with reading, problem assignments, and class participation will reap the rewards that students can expect from such efforts in other courses. Failing to do so will also lead to expected results.

There are some ways, however, in which studying physics is different from your studies in biology, history, or many other courses. Physics is not an area of study that can be mastered by memorizing discrete facts or by cramming before tests. Students sometimes bring study strategies to physics that have worked in other courses and are disappointed when they fail to work in their physics class. The suggestions that follow are sure-fire steps to getting the most out of your physics course and this textbook.

1. **Experiment.** Experiments play a key role in the development of physics but also in the growth of understanding for anyone approaching physics concepts. We often suggest in the text that you try simple experiments that might involve throwing a ball, walking across a room, or other very rudimentary activities. Do them right away as they arise in the text. Not only will you gain the benefit of increased blood flow to various parts of the body including the brain, but what follows in your reading will make more sense. Experience with everyday phenomena cannot be gained passively.
2. **Get the big picture.** Physics is a big-picture subject. Your understanding of Newton's laws of motion, for example, cannot be encapsulated by a formula or by memorizing the laws themselves. You need to see the entire context, understand the definitions, and work with how the laws are applied. The outlines and summaries provided at the beginning and end of each chapter can help to provide the context. They cannot stand alone, however. You need to place the examples and descriptions provided in the classroom and text in the framework provided by the outlines and summaries. If you grasp the big picture, the details will often follow.
3. **Explore questions.** The textbook provides a list of conceptual questions at the end of each chapter, but also raises questions in the body of the text. The greatest benefit is gained by attacking these questions first on your own and then by discussion with classmates. Write out answers to these questions using full sentences, not just short-answer phrases. Compare your answers with those provided at the back of the text for selected questions, but only after having a good crack at answering the questions yourself.
4. **Try the exercises.** The textbook also provides exercises and synthesis problems at the end of each chapter. Their purpose is to provide

practice with simple numerical applications of physics concepts. They are useful only if you do them yourself and write out the solution steps in such a way that you can follow your work. Copying answers and steps from classmates or other sources may gain points on the assignment but provides no benefit in understanding. As in sports and many other activities, success on physics exams will come to those who practice.

5. **Be there.** College students set their own priorities for use of time, and sometimes class attendance is not at the top of the list. In some classes, this may be justified by the nature of the benefit of class activities, but that is seldom the case in physics. The demonstrations, explanations, working of exercises, and class discussions that are usually part of what occurs during a physics class provide an invaluable aid to grasping the big picture and filling in holes in your understanding. The demonstrations alone are often worth the price of admission. (You do pay—it's called tuition.)
6. **Ask questions.** If the explanations of demonstrations or other issues are not clear, ask questions. If you are confused, chances are good that many other students are likewise befuddled. They will love you for raising the flag. Unless the instructor is unusually insecure, he or she will also love you for providing the opportunity to achieve better clarity. Physics instructors already know this stuff, so they sometimes have difficulty seeing where student hang-ups may lie. Questions provide the lubrication for moving things forward.
7. **Review understanding.** Preparing for tests should not be a matter of last-minute cramming and memorization. Instead, you should review your understanding of the big picture and question yourself on why we did what we did in answering questions and working exercises done previously. Memorization is usually pointless because many physics instructors provide or permit formula sheets that may include definitions and other information. Late-night cramming is counterproductive because it detracts from getting a good night's sleep. Sleep can be critical to having a clear head the next day to meet the challenges provided by the test.

Although there is an element of common sense in most of these suggestions, you will probably not be surprised to learn that many students do not approach things following these guidelines. Old habits are hard to break and peer pressure can also be a negative influence at times. Students fall into patterns that they know are ineffective, but are unable to climb out of the rut. We have done our duty in disclosing these secrets. You are on your own if you choose a different path. Let us know if it works.



# CHAPTER 2

Shutterstock/Ellon L'ivoor

## Describing Motion

### Chapter Overview

The main purpose of this chapter is to provide clear definitions and illustrations of the terms used in physics to describe motion, such as the motion of the car described in this chapter's opening example. Speed, velocity, and acceleration are crucial concepts for the analysis of motion in later chapters. Precise description is the first step to understanding. Without it, we remain awash in vague ideas that are not defined well enough to test our explanations.

Each numbered topic in this chapter builds on the previous section, so it is important to obtain a clear understanding of each topic before going on. The distinctions between speed and velocity and velocity and acceleration are particularly important.

UNIT ONE

18

### Chapter Outline

- 1 **Average and instantaneous speed.** How do we describe how fast an object is moving? How does instantaneous speed differ from average speed?
- 2 **Velocity.** How do we introduce direction into descriptions of motion? What is the distinction between speed and velocity?
- 3 **Acceleration.** How do we describe changes in motion? What is the relationship between velocity and acceleration?
- 4 **Graphing motion.** How can graphs be used to describe motion? How can the use of graphs help us gain a clearer understanding of speed, velocity, and acceleration?
- 5 **Uniform acceleration.** What happens when an object accelerates at a steady rate? How do the velocity and distance traveled vary with time when an object is uniformly accelerating?

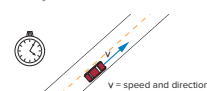
### Summary

The main purpose of this chapter is to introduce concepts that are crucial to a precise description of motion. To understand acceleration, you must first grasp the concept of velocity, which in turn builds on the idea of speed. The distinctions between speed and velocity, and between velocity and acceleration, are particularly important.

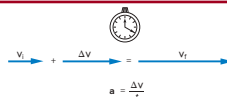
1 **Average and instantaneous speed.** Average speed is defined as the distance traveled divided by the time. It is the average rate at which distance is covered. Instantaneous speed is the rate at which distance is being covered at a given instant in time and requires that we use very short time intervals for computation.



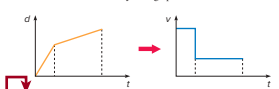
2 **Velocity.** The instantaneous velocity of an object is a vector quantity that includes both direction and size. The size of the velocity vector is equal to the instantaneous speed, and the direction is that of the object's motion.



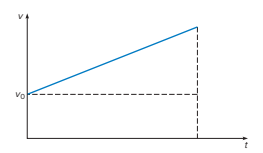
3 **Acceleration.** Acceleration is defined as the time rate of change of velocity and is found by dividing the change in velocity by the time. Acceleration is also a vector quantity. It can be computed as either an average or an instantaneous value. A change in the direction of the velocity can be as important as a change in magnitude. Both involve acceleration.



4 **Graphing motion.** Graphs of distance, speed, velocity, and acceleration plotted against time can illustrate relationships between these quantities. Instantaneous velocity is equal to the slope of the distance-time graph. The distance traveled is equal to the area under the velocity-time graph.



5 **Uniform acceleration.** When an object accelerates at a constant rate producing a constant-slope graph of velocity versus time, we say that it is uniformly accelerated. Graphs help us to understand the two formulas, describing how velocity and distance traveled vary with time for this important special case.



$$v = v_0 + at$$

$$d = v_0t + \frac{1}{2}at^2$$

The concepts of velocity and acceleration discussed in this chapter are often difficult to understand, particularly because we use the same terms in everyday life but often with different meanings. There are mastery quizzes and other helpful resources in Connect that will help you clarify your understanding of these ideas. We encourage you to try them.

### Key Terms

Speed, 19	Magnitude, 23	Average acceleration, 25
Average speed, 19	Vector, 23	Instantaneous acceleration, 25
Rate, 20	Vector quantity, 24	Slope, 28
Instantaneous speed, 21	Instantaneous velocity, 24	Uniform acceleration, 31
Velocity, 23	Acceleration, 24	

The chapter outline and chapter summary provide related frameworks for organizing concepts.

## study hint:

### How to Use the Features of This Book

This book has a number of features designed to make it easier for you to organize and grasp the concepts that we will explore. These features include the chapter overview and outline at the beginning of each chapter and the summary at the end of each chapter, as well as the structure of individual sections of the chapters. The questions, exercises, and synthesis problems at the end of each chapter also play an important role. How can these features be used to the best advantage?

### Chapter outlines and summaries

Knowing where you are heading before you set out on a journey can be the key to the success of your mission. Students get a better grasp of concepts if they have some structure or framework to help them to organize the ideas. Both the chapter overview and outline at the beginning of each chapter and the summary at the end are designed to provide such a framework. Having a clear idea of what you are trying to accomplish before you invest time in reading a chapter will make your reading more effective and enjoyable.

The list of topics and questions in the chapter outline can be used as a checklist for measuring your progress as you read. Each numbered topic in the outline, with its associated questions, pertains to a section of the chapter. The outline is designed to stimulate your curiosity by providing some blanks (unanswered questions) to be filled in by your reading. Without the blanks, your mind has no organizational structure to store the information. Without structure, recall is more difficult. You can use the questions in the outline to check the effectiveness of your reading. Can you answer all of the questions when you are done? Each section of a chapter also begins with questions, and the section subheadings are likewise often cast as questions. At the end of each section there is also an indented summary paragraph designed to help you tie the ideas in that section together.

The end-of-chapter summary gives a short description of the key ideas in each section, often cast in the form of answers to the questions raised in the outline (see diagram). Summaries provide a quick review, but they are no substitute for a careful reading of the main text. By following the same organizational structure as the outline, the summary reminds you where to find a more complete discussion of these ideas. The purpose of both the outlines and the summaries is to make your reading more organized and effective.

Studying any new discipline requires forming new patterns of thought that can take time to gel. The summaries at the end of each section, as well as at the end of the chapter, can help this gelling to take place. A structure is often built layer by layer, and the later layers will be shaky if the base is unstable.

### How should the questions and exercises be used?

At the end of each chapter you will find a group of questions, followed by a group of exercises, and, finally, by a small number of synthesis problems. Your grasp of the chapter will improve if you write out answers to the questions and exercises, either as assigned by your instructor or in independent study. The ideas contained in each chapter cannot be thoroughly mastered without this kind of practice.

The questions are crucial to helping you fix the important concepts and distinctions in your mind. Most of the questions call for a short answer as well as an explanation. A few of the questions, marked with asterisks, are more open-ended and call for lengthier responses. It is a good idea to write out the explanations in clear sentences when you answer these questions, because it is only through reinforcement that ideas become a part of you. Also, if you can explain something clearly to someone else, you understand it. A sample question and answer appears in example box 1.1.

The exercises are designed to give you practice in using the ideas and the related formulas to do simple computations. The exercises also help to solidify your understanding of concepts by giving you a sense of the units and the sizes of the quantities involved. Even though many of the exercises are straightforward enough to work in your head without writing much down, we recommend writing out the information given, the information sought, and the solution in the manner shown in example boxes 1.2 and 1.3 in section 1.3. This develops careful work habits that will help you avoid careless mistakes. Most students find the exercises easier than the questions. The sample exercises scattered through each chapter can help you get started.

The synthesis problems are more wide-ranging than the questions or exercises. They often involve features of both. Although not necessarily harder than the questions or exercises, they do take more time and are sometimes used to extend ideas beyond what was discussed in the chapter. Doing one or two of these in each chapter should build your confidence. They are

particularly recommended for those students who have worked the exercises and want to explore the topic in more depth.

Answers to the odd-numbered exercises, odd-numbered synthesis problems, and selected questions are found in the back of the book in appendix D. Looking up the answer before attempting the problem is self-defeating. It deprives you of practice in thinking things through on your own. Checking answers *after* you have worked an exercise can be a confidence builder. Answers should be used only to confirm or improve your own thinking.

### Home experiments and everyday phenomenon boxes

Reading or talking about physical ideas is useful, but there is no substitute for hands-on experience with the phenomena. You already have a wealth of experience with many of these phenomena, but you probably have not related it to the physical concepts you will be learning. Seeing things in new ways will make you a more astute observer.

In addition to the home experiments at the end of each chapter, we often suggest some simple experiments in the main text or in the study hints. We strongly recommend making these observations and doing the experiments. Lecture demonstrations can help, but doing something yourself imprints it vividly on your mind. There is excitement in discovering things yourself and seeing them in a new light.

The boxes that discuss everyday phenomena also give you practice in applying physical concepts. Most of the phenomena discussed in these boxes are familiar. The boxes allow us to explore these examples more thoroughly. Participating in these investigations of everyday phenomena can help bring the ideas home.

Connect has many features that will help you be successful in the course. The study hints given for each chapter often give a concise and thorough summary of the chapter. Read them to check if you have understood the key points of each chapter. There are both mastery quizzes and practice problems provided. Mastery quizzes test your conceptual understanding of the material. Many of your exam questions may be worded similar to these quizzes. Practice problems allow you to practice problems similar to the exercises at the end of each chapter in the text. Complete solutions are provided for these and you can check them after trying the problems.



Source: NASA/Langley Research Center (NASA-LaRC)

# Physics, the Fundamental Science

## Chapter Overview

The main objective of this chapter is to help you understand what physics is and where it fits in the broader scheme of the sciences. A secondary purpose is to acquaint you with the metric system of units and the advantages of the use of simple mathematics.

## Chapter Outline

- 1 What about energy?** What do concerns about global warming and climate change have to do with energy? How is physics involved in these discussions?
- 2 The scientific enterprise.** What is the scientific method? How do scientific explanations differ from other types of explanation?
- 3 The scope of physics.** What is physics? How is it related to the other sciences and to technology? What are the major subfields of physics?
- 4 The role of measurement and mathematics in physics.** Why are measurements so important? Why is mathematics so extensively used in science? What are the advantages of the metric system of units?
- 5 Physics and everyday phenomena.** How is physics related to everyday experience and common sense? What are the advantages of using physics to understand common experience?

Imagine that you are riding your bike on a country road on an Indian-summer afternoon. The sun has come out after a brief shower, and as the rain clouds move on, a rainbow appears in the east (fig. 1.1). A leaf flutters to the ground, and an acorn, shaken loose by a squirrel, misses your head by only a few inches. The sun is warm on your back, and you are at peace with the world around you.

No knowledge of physics is needed to savor the moment, but your curiosity may bring some questions to mind. Why does the rainbow appear in the east rather than in the west, where it may also be raining? What causes the colors to appear? Why does the acorn fall more rapidly than the leaf? Why is it easier to keep your bicycle upright while you are moving than when you are standing still?

Your curiosity about questions like these is similar to what motivates scientists. Learning to devise and apply theories or models that can be used to understand, explain, and predict such phenomena can be a rewarding intellectual game. Crafting an explanation and testing it with simple experiments or

observations is fun. That enjoyment is often missed when the focus of a science course is on accumulating facts.

This book can enhance your ability to enjoy the phenomena that are part of everyday experience. Learning to produce your own explanations and to perform simple experimental tests can be gratifying. The questions posed here lie in the realm of physics, but the spirit of inquiry and explanation is found throughout science and in many other areas of human activity. The greatest rewards of scientific study are the fun and excitement that come from understanding something that has not been understood before. This is true whether we are talking about a physicist making a major scientific breakthrough or about a bike rider understanding how rainbows are formed. There are also benefits to understanding the physics concepts that underlie issues arising in political and policy debates. The next section introduces questions in the very important areas of energy use and climate change. These involve everyday phenomena of a more pressing nature than rainbows.



**Figure 1.1** Rainbows appear to the east in late afternoon. How can this phenomenon be explained? (See everyday phenomenon box 17.1.) *Courtesy of Sally Cantrell Griffith*

## Study Hint

If you have a clear idea of what you want to accomplish before you begin to read a chapter, your reading will be more effective. The questions in the chapter outline—as well as those in the subheadings of each section—can serve as a checklist for measuring your progress as you read. A clear picture of what questions are going to be addressed and where the answers will be found forms a mental road map to guide you through the chapter. Take a few minutes to study the outline and fix this road map in your mind. It will be time well spent.

## 1.1 What about Energy?

Suppose that you have just emerged from a heated argument with a friend about global warming and energy. Your friend has a different political bent than your own and you suspect that his or her opinions on global warming are simply a matter of political bias. However, since you may know very little about the details of energy issues, you are really not in a position to counter the arguments. Where do you go from there?

All of us find ourselves in this position from time to time. Energy issues lie at the heart of the political debate on global

warming and climate change. Understanding the basics of these issues is important to politicians, policymakers, and ordinary citizens who discuss these issues and vote for or against ballot measures and candidates.

What is energy and how is it used? Which energy sources are renewable and which are not? What can you do to understand and coherently discuss energy issues?

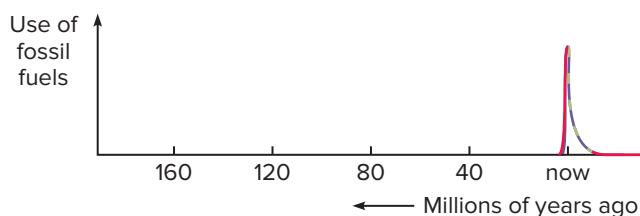
### How is energy involved in the global warming debate?

Much of our use of energy involves the burning of fossil fuels. The carbon that is released in this process was locked up millions of years ago in coal, oil, and natural gas. Therefore, this carbon has not been a part of ongoing processes that absorb and release carbon dioxide. From the perspective of geological time frames, this burning of fossil fuels is happening on a very short timescale. It is a geologic flash in the pan. (See fig. 1.2.)

What are the natural ongoing processes involving carbon? Trees and other green plants absorb carbon dioxide from the atmosphere—it is essential to their growth. When the plants die, they decay, releasing some carbon dioxide back to the atmosphere. Forest or brush fires release carbon dioxide to the atmosphere more quickly. A small portion of the carbon in plants may get buried and may ultimately, over a period of many millions of years, be converted to a fossil fuel. When we burn wood as a fuel, we release carbon dioxide, but this has no long-term effect on greenhouse gases, because the carbon dioxide released was absorbed from the atmosphere not too long ago. Wood burning does emit particles of ash and other pollutants that can have undesirable effects.

The reduction of forest cover to create cities, highways, and the like therefore also affects the balance of carbon dioxide in the atmosphere. But it is the burning of fossil fuels that has the greatest impact, and that is where the focus must be if we are to change the rate at which greenhouse gases are increasing. This, then, gets us into the familiar debates on how we produce energy, how we use energy, and what can be done to change these patterns.

But what is energy? Although the term is bandied about all the time and we all think we have some sense of what it means, it turns out that providing a satisfactory definition is



**Figure 1.2** A schematic sketch of our use of fossil fuels on a geologic timescale. Coal, oil, and natural gas were produced from 40 million to 200 million years ago.

not a trivial matter. Many of the misunderstandings involved in the global-warming debate result from poor understanding of what energy is. For example, is hydrogen a source of energy or merely a means of transporting energy, and what is the difference (see everyday phenomenon box 18.1)? Much of the political hoopla regarding the hydrogen economy failed to address this basic question.

In this book, we will define energy initially in chapter 6, titled “Energy and Oscillations.” The prior chapters on mechanics provide the underpinnings for the introduction of the energy concept. In fact, it is difficult to understand how energy is defined without having some knowledge of mechanics. Following the introduction in chapter 6, energy ideas appear and are expanded in all of the chapters that follow. These ideas are central to all of physics.

### Physics and energy

Understanding the definition of energy is obviously a good starting point for discussions of energy policies. The meaning of energy and the nature of energy transformations are firmly within the realm of physics. How we convert one form of energy to another, how we can use energy efficiently, and what it means to conserve energy are all topics that will come up in this book and in the study of physics more generally.

Many other topics within the realm of physics also play important roles in addressing energy issues. For example, transportation is a major area of energy use in our society. Cars, trucks, airplanes, boats, and trains are all part of the mix. They all utilize energy in some manner, but their basic physics can be understood from ideas in mechanics that are discussed in the early chapters of this book before energy ideas are introduced.

In the short term, one of our best options for reducing our use of fossil fuels involves energy conservation. Changes can be made in this realm more quickly than in the development of alternative energy resources. The rising costs of gasoline, diesel fuel, and fuel oil for heating have already been shown to significantly affect our energy consumption. Strictly speaking, we do not really consume energy—we simply convert it to less usable forms (see chapter 6 and chapter 11). The study of the mechanics of transportation (chapters 2–4) and the thermodynamics of engines (chapters 9–11) play important roles in energy conservation.

Questions regarding choices on how to generate usable forms of energy all involve physics concepts. Is it better to use natural gas than nuclear power (fig. 1.3), for example? Nuclear power has been a particularly contentious issue for many years and has suffered somewhat from the whims of political fashion. What is nuclear energy, and should we be rushing into a new commitment to its use, or should we be afraid of going there? Natural gas releases less carbon dioxide per unit of energy generated than does coal or oil, and it is a relatively clean fuel. It is, however, an emitter of greenhouse gases, and its long-term supply is questionable.





**Figure 1.3** Are nuclear power plants our salvation or relics of the past? Steve Allen/Brand X Pictures/Alamy Stock Photo

Nuclear power does not involve the burning of a carbon-based fuel, so it does not release carbon dioxide into the atmosphere. For this reason, it is now receiving renewed attention as a possible resource for reducing our “carbon footprint.” Nuclear power does involve the mining of a limited resource, uranium, and has serious environmental issues associated with mining, possible accidents, and waste disposal. However, the utilization of any energy resource has environmental consequences, so the weighing of such issues must be an important aspect of our decision making.

We will not provide a definitive answer to the questions we have just raised. What we will do is discuss some of the basic physics underlying nuclear power, natural-gas power plants, and other resources used in electric power generation. Fossil-fuel power plants are discussed in chapter 11, and nuclear power is addressed in chapter 19. Many other means of generating energy will also be discussed, and some of the pros and cons of their use will be indicated in many sections of the book.

After studying these issues, will you win your argument with your friend? Perhaps not, but you will be in a much better position to debate the questions. Both of you may come to a better understanding of the real issues involved.

Political debates on climate change and energy utilization are important features of current events. The two topics are intimately related, because the burning of fossil fuels for energy generation is the primary cause of release into the atmosphere of the greenhouse gas carbon dioxide. Physics is the science of energy and is therefore heavily involved in decisions on energy conversion and utilization. Thus, the study of physics provides a basis for understanding some of the fundamental issues in these debates.

## 1.2 The Scientific Enterprise

How do scientists go about explaining something like the temperature change of the Earth or the rainbow described in the introduction? How do scientific explanations differ from other types of explanations? Can we count on the scientific method to explain almost anything? It is important to understand what science can and cannot do.

Philosophers have devoted countless hours and pages to questions about the nature of knowledge, and of scientific knowledge in particular. Many issues are still being refined and debated. Science grew rapidly during the twentieth century and has had a tremendous impact on our lives. Innovations in medicine, communications, transportation, and computer technology all have resulted from advances in science. What is it about science that explains its impressive advances and steady expansion?

### Science and rainbows

Let’s consider a specific example of how a scientific explanation comes to be. Where would you turn for an explanation of how rainbows are formed? If you return from your bike ride with that question on your mind, you might look up *rainbow* in a textbook on physics or on the Internet and read the explanation found there. Are you behaving like a scientist?

The answer is both yes and no. Many scientists would do the same if they were unfamiliar with the explanation. When we do this, we appeal to the authority of the textbook author and to those who preceded the author in inventing the explanation. Appeal to authority is one way of gaining knowledge, but you are at the mercy of your source for the validity of your explanation. You are also hoping that someone has already raised the same question and done the work to create and test an explanation.

Suppose you go back three hundred years or more and try the same approach. One book might tell you that a rainbow is a painting of the angels. Another might speculate on the nature of light and its interactions with raindrops but be quite tentative in its conclusions. Either of these books might have seemed authoritative in its day. Where, then, do you turn? Which explanation will you accept?

If you are behaving like a scientist, you might begin by reading the ideas of other scientists about light and then test these ideas against your own observations of rainbows. You would carefully note the conditions when rainbows appear, the position of the sun relative to you and the rainbow, and the position of the rain shower. What is the order of the colors in the rainbow? Have you observed that order in other phenomena?

You would then invent an explanation, or **hypothesis**, using current ideas on light and your own guess about what happens as light passes through a raindrop. You could devise



**Figure 1.4** French physicist and chemist Marie Curie (1867–1937) gives a lecture to an audience of men and women at the Conservatory of Arts and Crafts, Paris, 1925. Curie won Nobel prizes for both Physics (1903) and Chemistry (1911). Jacques Boyer/Roger Violette/Getty Images

experiments with water drops or glass beads to test your hypothesis. (See chapter 17 for a modern view of how rainbows are formed.)

If your explanation is consistent with your observations and experiments, you could report it by giving a paper or talk to scientific colleagues. They may critique your explanation, suggest modifications, and perform their own experiments to confirm or refute your claims. If others confirm your results, your explanation will gain support and eventually become part of a broader **theory**\* about phenomena involving light. The experiments you and others do may also lead to the discovery of new phenomena, which will call for refined explanations and theories.

What is critical to the process just described? First is the importance of careful observation. Another aspect is the idea of testability. An acceptable scientific explanation should suggest some means to test its predictions by observations or experiment. Saying that rainbows are the paintings of angels may be poetic, but it certainly is not testable by mere humans. It is not a scientific explanation.

Another important part of the process is a social one, the communication of your theory and experiments to colleagues (fig. 1.4). Submitting your ideas to the criticism (at times blunt) of your peers is crucial to the advancement of science. Communication is also important

\*The concept of a theory, as used in science, is often misunderstood. It is much more than a simple hypothesis. A theory consists of a set of basic principles from which many predictions can be deduced. The basic principles involved in the theory are often widely accepted by scientists working in the field.

in assuring your own care in performing the experiments and interpreting the results. A scathing attack by someone who has found an important error or omission in your work is a strong incentive for being more careful in the future. One person working alone cannot hope to think of all the possible ramifications, alternative explanations, or potential mistakes in an argument or theory. The explosive growth of science has depended heavily on cooperation and communication.

### What is the scientific method?

Is there something we can call the **scientific method** within this description, and if so, what is it? The process just described is a sketch of how the scientific method works. Although there are variations on the theme, this method is often described as shown in table 1.1.

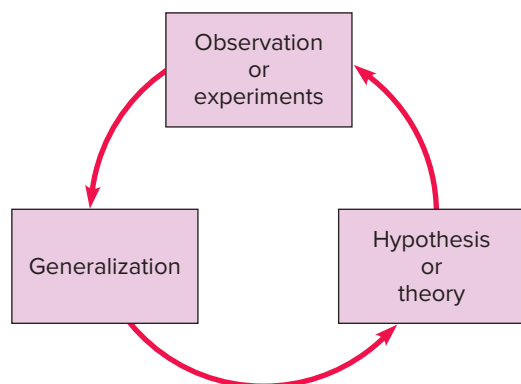
The steps in table 1.1 are all involved in our description of how to develop an explanation of rainbows. Careful observation may lead to **empirical laws** for when and where rainbows appear. An empirical law is a generalization derived from experiments or observations. An example of an empirical law is the statement that we see rainbows with the sun at our backs as we look at the rainbow. This is an important clue for developing our hypothesis, which must be consistent with this rule. The hypothesis, in turn, suggests ways of producing rainbows artificially that could lead to experimental tests and, eventually, to a broader theory.

This description of the scientific method is not bad, although it ignores the critical process of communication. Few scientists are engaged in the full cycle that these steps suggest. Theoretical physicists, for example, may spend all of their time with step 3. Although they have some interest in experimental results, they may never do any experimental work themselves. Today, little science is done by simple observation, as step 1 may seem to imply. Most observations are designed to test a hypothesis or existing theory and often involve carefully controlled

**Table 1.1**

#### Steps in the Scientific Method

1. Careful observation of natural phenomena.
2. Formulation of rules or empirical laws based on generalizations from these observations and experiments.
3. Development of hypotheses to explain the observations and empirical laws, and the refinement of hypotheses into theories.
4. Testing of the hypotheses or theories by further experiment or observation.



**Figure 1.5** The scientific method cycles back to observations or experiments as we seek to test our hypotheses or theories. Communication with peers is involved in all stages of the process.

experiments. Although the scientific method is presented here as a stepwise process, in reality these steps often happen simultaneously with much cycling back and forth between steps (fig. 1.5).

The scientific method is a way of testing and refining ideas. Note that the method applies only when experimental tests or other consistent observations of phenomena are feasible. Testing is crucial for weeding out unproductive hypotheses; without tests, rival theories may compete endlessly for acceptance. Example box 1.1 provides a sample question and response illustrating these ideas.

### How should science be presented?

Traditional science courses focus on presenting the results of the scientific process rather than the story of how scientists arrived at these results. This is why the general public often sees science as a collection of facts and established theories. To some extent, that charge could be made

## Example Box 1.1

### Sample Question: How Reliable Is Astrology?

**Question:** Astrologers claim that many events in our lives are determined by the positions of the planets relative to the stars. Is this a testable hypothesis?

**Answer:** Yes, it could be tested if astrologers were willing to make explicit predictions about future events that could be verified by independent observers. In fact, astrologers usually carefully avoid doing this, preferring to cast their predictions as vague statements subject to broad interpretation. This prevents clean tests. Astrology is not a science!

against this book, because it describes theories that have resulted from the work of others without giving the full picture of their development. Building on the work of others, without needing to repeat their mistakes and unproductive approaches, is a necessary condition for human and scientific progress.

This book attempts to engage you in the process of making your own observations and developing and testing your own explanations of everyday phenomena. By doing home experiments or observations, constructing explanations of the results, and debating your interpretations with your friends, you will appreciate the give-and-take that is the essence of science.

Whether or not we are aware of it, we all use the scientific method in our everyday activities. The case of the malfunctioning coffeemaker described in everyday phenomenon box 1.1 provides an example of scientific reasoning applied to ordinary troubleshooting.

The process of science begins with, and returns to, observations of or experiments on natural phenomena. Observations may suggest empirical laws, and these generalizations may be incorporated into a more comprehensive hypothesis. The hypothesis is then tested against more observations or by controlled experiments to form a theory. Working scientists are engaged in one or more of these activities, and we all use the scientific method on everyday problems.

### Debatable Issue

We are often told that there is a strong consensus among climate scientists that global warming and climate change are being caused by human activity that is producing growing amounts of greenhouse gases, particularly carbon dioxide, in the atmosphere. Does a strong consensus among scientists imply that this idea is correct? Why or why not?

## 1.3 The Scope of Physics

Where does physics fit within the sciences? Since this book is about physics, rather than biology, chemistry, geology, or some other science, it is reasonable to ask where we draw the lines between the disciplines. It is not possible, however, to make sharp distinctions among the disciplines or to provide a definition of physics that will satisfy everyone. The easiest way to give a sense of what physics is and does is by example—that is, by listing some of its subfields and exploring their content. First, let's consider a definition, however incomplete.

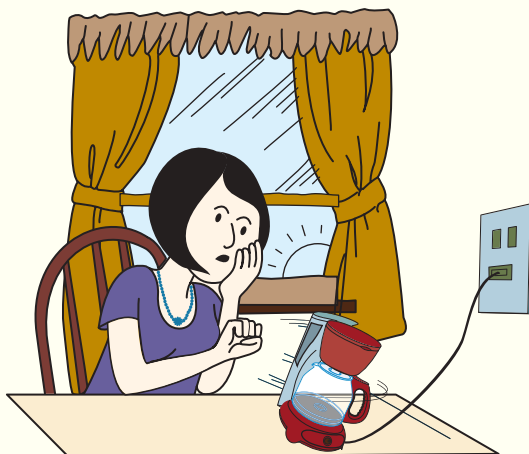
## Everyday Phenomenon

## Box 1.1

### The Case of the Malfunctioning Coffeemaker

**The Situation.** It is Monday morning and you are, as usual, only half-awake and feeling at odds with the world. You are looking forward to reviving yourself with a freshly brewed cup of coffee when you discover that your coffeemaker refuses to function. Which of these alternatives is most likely to work?

1. Pound on the appliance with the heel of your hand.
2. Search desperately for the instruction manual, which you probably threw away two years ago.
3. Call a friend who knows about these things.
4. Apply the scientific method to troubleshoot the problem.



Fixing a malfunctioning coffee pot—alternative 1.

**The Analysis.** All of these alternatives have some chance of success. The sometimes positive response of electrical or mechanical appliances to physical abuse is well documented. The second two alternatives are both forms of appeal to authority that could produce results. The fourth alternative, however, may be the most productive and quickest, barring success with alternative 1.

How would we apply the scientific method as outlined in table 1.1 to this problem? Step 1 involves calmly observing the symptoms of the malfunction. Suppose that the coffeemaker simply refuses to heat up. When the switch is turned on, no

sounds of warming water are heard. You notice that no matter how many times you turn the switch on or off, no heat results. This is the kind of simple generalization called for in step 2.

We can now generate some hypotheses about the cause of the malfunction, as suggested in step 3. Here are some candidates:

- a. The coffeemaker is not plugged in.
- b. The external circuit breaker or fuse has tripped.
- c. The power is off in the entire house or neighborhood.
- d. An internal fuse in the coffeemaker has blown.
- e. A wire has become loose or burned through inside the coffeemaker.
- f. The internal thermostat of the coffeemaker is broken.

No detailed knowledge of electrical circuits is needed to check these possibilities, although the last three call for more sophistication (and are more trouble to check) than the first three. The first three possibilities are the easiest to check and should be tested first (step 4 in our method). A simple remedy such as plugging in the coffeemaker or flipping on a circuit breaker may put you back in business. If the power is off in the building, other appliances (lights, clocks, and so on) will not work, either, which provides an easy test. There may be little that you can do in this case, but at least you have identified the problem. Abusing the coffeemaker will not help.

The appliance may or may not have an internal fuse. If it is blown, a trip to the hardware store may be necessary. A problem like a loose wire or a burnt-out connection often becomes obvious by looking inside after you remove the bottom of the coffeemaker or the panel where the power cord comes in. (You must unplug the appliance before making such an inspection!) If one of these alternatives is the case, you have identified the problem, but the repair is likely to take more time or expertise. The same is true of the last alternative.

Regardless of what you find, this systematic (and calm) approach to the problem is likely to be more productive and satisfying than the other approaches. Troubleshooting, if done this way, is an example of applying the scientific method on a small scale to an ordinary problem. We are all scientists if we approach problems in this manner.

### How is physics defined?

Physics can be defined as the *study of the basic nature of matter and the interactions that govern its behavior*. It is the most fundamental of the sciences. The principles and theories of physics can be used to explain the fundamental interactions involved in chemistry, biology, and other sciences at

the atomic or molecular level. Modern chemistry, for example, uses the physical theory of *quantum mechanics* to explain how atoms combine to form molecules. Quantum mechanics was developed primarily by physicists in the early part of the twentieth century, but chemists and chemical knowledge also played important roles. Ideas about

energy that arose initially in physics are now used extensively in chemistry, biology, and other sciences.

The general realm of science is often divided into the life sciences and the physical sciences. The life sciences include the various subfields of biology and the health-related disciplines that deal with living organisms. The physical sciences deal with the behavior of matter in both living and nonliving systems. In addition to physics, the physical sciences include chemistry, geology, astronomy, oceanography, and meteorology (the study of weather). Physics underlies all of them.

Physics is also generally regarded as the most quantitative of the sciences. It makes heavy use of mathematics and numerical measurements to develop and test its theories. This aspect of physics has often made it seem less accessible to students, even though the models and ideas of physics can be described more simply and cleanly than those of other sciences. As we will discuss in section 1.4, mathematics serves as a compact language, allowing briefer and more precise statements than would be possible without its use. However, the quantitative skills needed to understand this book are minimal.

### What are the major subfields of physics?

The primary subfields of physics are listed and identified in table 1.2. Mechanics, which deals with the motion (or lack of motion) of objects under the influence of forces, was the first subfield to be explained with a comprehensive theory. Newton's theory of mechanics, which he developed in the last half of the seventeenth century, was the first full-fledged physical theory that made extensive use of mathematics. It became a prototype for subsequent theories in physics.

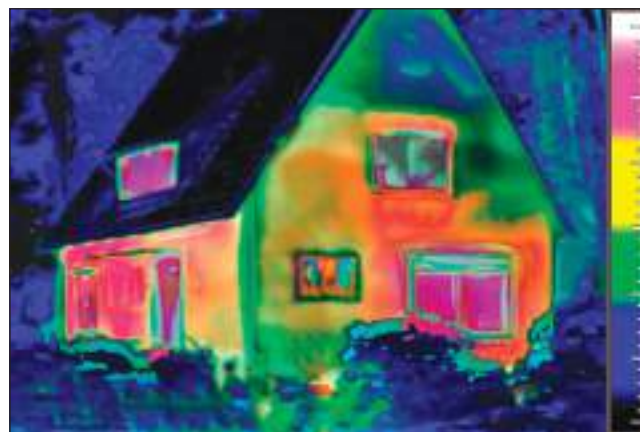
The first four subfields listed in table 1.2 were well developed by the beginning of the twentieth century, although all have continued to advance since then. These subfields—mechanics, thermodynamics, electricity and magnetism, and

optics—are sometimes grouped as **classical physics**. The last four subfields—atomic physics, nuclear physics, particle physics, and condensed-matter physics—are often grouped under the heading of **modern physics**, even though all of the subfields are part of the modern practice of physics. The distinction is made because the last four subfields all emerged during the twentieth century and only existed in rudimentary forms before the turn of that century. In addition to the subfields listed in table 1.2, many physicists work in interdisciplinary fields such as biophysics, geophysics, or astrophysics.

The photographs in this section (fig 1.6, fig. 1.7, fig. 1.8, and fig. 1.9) illustrate characteristic activities or applications



**Figure 1.6** A surgeon using a laser. *Larry Mulvehill/Corbis/SuperStock*



**Figure 1.7** An infrared photograph showing patterns of heat loss from a house is an application of thermodynamics. *Dirk Püschel/Hemera/Getty Images*

**Table 1.2**

The Major Subfields of Physics

**Mechanics.** The study of forces and motion.

**Thermodynamics.** The study of temperature, heat, and energy.

**Electricity and magnetism.** The study of electric and magnetic forces and electric current.

**Optics.** The study of light.

**Atomic physics.** The study of the structure and behavior of atoms.

**Nuclear physics.** The study of the nucleus of the atom.

**Particle physics.** The study of subatomic particles (quarks, etc.).

**Condensed-matter physics.** The study of the properties of matter in the solid and liquid states.



**Figure 1.8** A power plant at Nellis Air Force Base utilizes photovoltaic solar cells. *Stocktrek Images/Getty Images*



**Figure 1.9** The Large Hadron Collider (LHC) is an accelerator used to study interactions of subatomic particles at very high energies. It is located at CERN, the European Particle-physics laboratory in Switzerland. *Fabrice Coffrini/AFP/Getty Images*

of the subfields. The invention of the laser has been an extremely important factor in the rapid advances now taking place in optics, as well as many advances in the medical field (fig. 1.6). The development of the infrared camera has provided a tool for the study of heat flow from buildings, which involves thermodynamics (fig. 1.7). The rapid growth in consumer electronics, as seen in the availability of laptop computers, smartphones, and many other “essential” personal paraphernalia, has been made possible by developments in condensed-matter physics. These developments, as well as the development of photovoltaic solar cells (fig 1.8), all involve applications of semiconductors. Particle physicists use particle accelerators to study the interactions of subatomic particles in high-energy collisions. The Large Hadron Collider (fig. 1.9) was used in the discovery of the Higgs Boson in 2012.

Science and technology depend on each other for progress. Physics plays an important role in the education and work of engineers, whether they specialize in electrical, mechanical, nuclear, or other engineering fields. In fact, people with physics degrees often work as engineers when they are employed in industry. The lines between physics and engineering, or research and development, often blur. Physicists are generally concerned with developing a fundamental understanding of phenomena, and engineers with applying that understanding to practical tasks or products, but these functions often overlap.

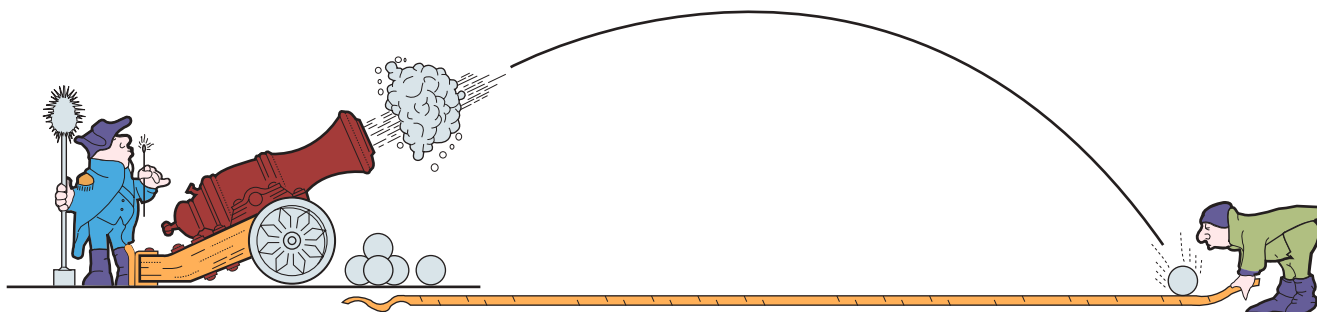
One final point: Physics is fun. Understanding how a bicycle works or how a rainbow is formed has an appeal that anyone can appreciate. The thrill of gaining insight into the workings of the universe can be experienced at any level. In this sense, we can all be physicists.

Physics is the study of the basic characteristics of matter and its interactions. It is the most fundamental of the sciences; many other sciences build on ideas from physics. The major subfields of physics are mechanics, electricity and magnetism, optics, thermodynamics, atomic and nuclear physics, particle physics, and condensed-matter physics. Physics plays an important role in engineering and technology, but the real fun of physics comes from understanding how the universe works.

## 1.4 The Role of Measurement and Mathematics in Physics

If you go into your college library, find a volume of *Physical Review* or some other major physics journal, and open it at random, you are likely to find a page with many mathematical symbols and formulas. It would probably be incomprehensible to you. In fact, even many physicists who are not specialists in the particular subfield covered by the article might have difficulty making sense of that page, because they would not be familiar with the particular symbols and definitions.

Why do physicists make such extensive use of mathematics in their work? Is knowledge of mathematics essential to understanding the ideas being discussed? Mathematics is a compact language for representing the ideas of physics that makes it easier to precisely state and manipulate the relationships between the quantities that we measure in physics. Once you are familiar with the language, its mystery disappears and its usefulness becomes more obvious. Still, this book uses mathematics in a very limited manner, because most ideas of physics can be discussed without extensive use of mathematics.



**Figure 1.10** Cannonballs and a measuring tape: the proof lies in the measurement.

### Why are measurements so important?

How do we test theories in physics? Without careful measurements, vague predictions and explanations may seem reasonable, and making choices between competing explanations may not be possible. A quantitative prediction, on the other hand, can be tested against reality, and an explanation or theory can be accepted or rejected based on the results of measurements. If, for example, one hypothesis predicts that a cannonball will land 100 meters from us and another predicts a distance of 200 meters under the same conditions, firing the cannon and measuring the actual distance provide persuasive evidence for one of these hypotheses (fig. 1.10). The rapid growth and successes of physics began when the idea of making precise measurements as a test was accepted.

Life is full of situations in which measurements and measurable quantities, as well as the ability to express relationships between them, are important. Imagine that you are working on a tree farm and want to impress your boss. You have just finished planting 300 seedlings on 2.4 acres, when your boss asks how many seedlings will be needed for a second location of 4 acres. You don't want to waste money on too many seedlings; nor do you want too few. Perhaps you can solve the problem in your head, but this might be hard to describe in words to your boss and might just confuse the issue.

### How can mathematics help?

You can reduce the confusion by creating a word statement for this situation. You can say, "The quantity needed for 4 acres is related to the quantity for 2.4 acres as 4 is to 2.4." This still takes quite a few words, though, and such a **proportion** statement may not be familiar to the boss.

To make your statement briefer, you can use the symbols  $Q$  to represent the quantity of seedlings needed for 4 acres and  $Q_o$  to represent the quantity needed for the original 2.4 acres, then express them as a mathematical equation:

$$\frac{Q}{Q_o} = \frac{4}{2.4}$$

Using symbols is simply a compact way of saying the same thing you previously expressed in words. This compact

statement also has the advantage of making it easier for you to manipulate the relationship. For example, if you multiply both sides of this equation by  $Q_o$ , it takes the form

$$Q = \left(\frac{4}{2.4}\right) Q_o$$

which, in words, says that the quantity needed for 4 acres is  $(4/2.4)$  times the quantity needed for 2.4 acres. If, instead, you want to find the number needed for 8 acres, you can easily see it is just  $Q = (8/2.4) Q_o$ . If you are comfortable with fractions, you can use this relationship to quickly find the proper quantity for any number of acres.

A common, everyday situation in which you might use this idea of proportion to your advantage is with recipes. Everyday phenomenon box 1.2 addresses the challenge of taking a frosting recipe for two cakes and scaling it up for five cakes.

There are a few important points to these examples. First, making measurements and using measurable quantities are both a routine and an important part of everyday experience. Second, using symbols to represent quantities in a mathematical statement is a shorter way of expressing an idea involving numbers than the same statement in words. Using mathematics also makes it easier to manipulate relationships to construct concise arguments. These are the reasons that physicists (and many other people) find mathematical statements useful.

### Why are metric units used?

*Units of measurement* are an essential part of any measurement. We do not communicate clearly if we just state a number. If you just talked about adding  $1\frac{1}{3}$  of milk, for example, your statement would be incomplete. You need to indicate whether you are talking about cups, pints, or milliliters.

The liter and milliliter are *metric* units of volume. Cups, pints, quarts, and gallons are holdovers from the older English system of units. Most countries have now adopted the **metric system**, which has several advantages over the English system still used in the United States. The main advantage of the metric system is its use of standard prefixes to represent multiples of 10, making unit conversion within the

## Everyday Phenomenon

## Box 1.2

## Scaling a Recipe

**The Situation.** You have an excellent recipe for vanilla frosting, which you have made to ice two cakes. However, your friends want you to take five cakes to your annual club meeting. How do you scale up the recipe, so that you have just enough icing for five cakes? How can your newfound understanding of proportions help you?



Putting finishing touches on a cake.

**The Analysis.** According to our understanding of proportions, the quantity of frosting needed for five cakes is to the quantity needed for two cakes as 5 is to 2. Another way we can look at this is by using symbols. If we let  $Q_2$  be the quantity needed for two cakes and  $Q_5$  be the quantity needed for five cakes, then we can write the relationship as

$$\frac{Q_5}{Q_2} = \frac{5}{2}$$

We can rewrite this equation to solve for  $Q_5$  (which is the quantity we are looking for) by multiplying both sides by  $Q_2$ :

$$(Q_2) \left( \frac{Q_5}{Q_2} \right) = (Q_2) \left( \frac{5}{2} \right)$$

Notice that on the left-hand side the  $Q_2$  in the numerator cancels the  $Q_2$  in the denominator, so the equation becomes

$$Q_5 = (Q_2) \left( \frac{5}{2} \right)$$

In words, this translates to “the quantity needed for five cakes is equal to the quantity used for two cakes times the ratio (5/2).”

Now, let’s look at the recipe. The recipe for two cakes is as follows:

- 16 cups confectioners’ sugar
- 1 cup butter, softened
- 1 cup whole milk
- 1 tablespoon vanilla extract

Combine butter, milk, and vanilla. Beat on medium speed until smooth. Gradually add sugar while beating until smooth and fluffy.

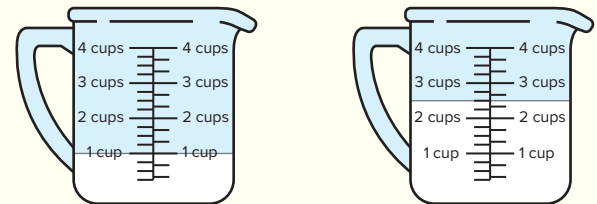
To expand the recipe for five cakes, we would multiply each quantity by (5/2). Let’s look at the amount of milk:

$$(1 \text{ cup}) \left( \frac{5}{2} \right) = \frac{5}{2} \text{ cups} = 2\frac{1}{2} \text{ cups} = 2.5 \text{ cups}$$

We can do the same for the other ingredients. Our revised frosting recipe for five cakes is thus

- 40 cups confectioners’ sugar
- 2.5 cups butter, softened
- 2.5 cups whole milk
- 2.5 tablespoons vanilla extract

Once you know how to use proportions to scale recipes up (or down), you will be much more confident when determining the quantities needed. This skill is useful in many aspects of everyday living. Determining quantities such as the amount of paint needed for a project, or the number of pizzas to order, becomes less problematic. In fact, you just might find yourself the person your friends turn to when scaling quantities up or down.



Two measuring cups, one containing enough milk for frosting two cakes and one for frosting five cakes.

system quite easy. The fact that a kilometer (km) is 1000 meters and a centimeter (cm) is  $1/100$  of a meter, and that the prefixes *kilo* and *centi* always mean 1000 and  $1/100$ , makes these conversions easy to remember (see table 1.3).

To convert 30 centimeters to meters, all we have to do is move the decimal point two places to the left to get 0.30 meter. Moving the decimal point two places to the left is equivalent to dividing by 100.



Table 1.3

Prefix	Meaning		
	in figures	in scientific notation	in words
tera	1 000 000 000 000	$= 10^{12}$	= 1 trillion
giga	1 000 000 000	$= 10^9$	= 1 billion
mega	1 000 000	$= 10^6$	= 1 million
kilo	1000	$= 10^3$	= 1 thousand
centi	$\frac{1}{100}$ = 0.01	$= 10^{-2}$	= 1 hundredth
milli	$\frac{1}{1000}$ = 0.001	$= 10^{-3}$	= 1 thousandth
micro	$\frac{1}{1\,000\,000}$ = $\frac{1}{10^6}$	$= 10^{-6}$	= 1 millionth
nano	$\frac{1}{1\,000\,000\,000}$ = $\frac{1}{10^9}$	$= 10^{-9}$	= 1 billionth
pico	$= \frac{1}{10^{12}}$	$= 10^{-12}$	= 1 trillionth

Table 1.3 is a list of the common prefixes used in the metric system. (See appendix B for a discussion of the **powers of 10**, or **scientific notation**, used for describing very large and very small numbers.) The basic unit of volume in the metric system is the liter (L), which is slightly larger than a quart (1 liter = 1.057 quarts). A milliliter (mL) is  $\frac{1}{1000}$  of a liter, a convenient size for quantities in recipes. One milliliter is also equal to  $1 \text{ cm}^3$ , or 1 cubic centimeter, so there is a simple relationship between the length and volume measurements in the metric system. Such simple relationships are hard to find in the English system, where 1 cup is  $\frac{1}{4}$  of a quart, and a quart is 67.2 cubic inches.

### Example Box 1.2

#### Sample Exercise: Length Conversions

If you are told that there are 2.54 cm in 1 inch,

- How many centimeters are there in 1 foot (12 inches)?
- How many meters does 1 foot represent?

- a. 1 inch = 2.54 cm  
1 foot = 12 inches  
1 foot = ? (in cm)

$$(1 \text{ ft}) \left( \frac{12 \text{ in}}{1 \text{ ft}} \right) \left( \frac{2.54 \text{ cm}}{1 \text{ in}} \right) = 30.5 \text{ cm}$$

$$\mathbf{1 \text{ foot} = 30.5 \text{ cm}}$$

- b. 1 foot = 30.5 cm  
1 m = 100 cm  
1 foot = ? (in m)

$$(1 \text{ ft}) \left( \frac{30.5 \text{ cm}}{1 \text{ ft}} \right) \left( \frac{1 \text{ m}}{100 \text{ cm}} \right) = 0.305 \text{ m}$$

$$\mathbf{1 \text{ foot} = 0.305 \text{ m}}$$

Lines drawn through the units indicate cancellation.

The metric system predominates in this book. English units will be used occasionally because they are familiar to many and can help in learning new concepts. Most people in the United States still relate more readily to distances in miles than in kilometers, for example. That there are 5280 feet in a mile is a nuisance, however, compared to the tidy 1000 meters in 1 kilometer. Becoming familiar with the metric system is a worthy objective. Your ability to participate in international trade (for business or pleasure) will be enhanced if you are familiar with the system of units used in most of the world. Example boxes 1.2 and 1.3 provide unit conversion exercises involving metric units.

### Example Box 1.3

#### Sample Exercise: Rate Conversions

If the rate of flow in an automatic watering system is 2 gallons/hour, how many milliliters per minute is this?

- 1 gallon = 3.786 liters  
1 liter = 1000 mL  
2 gal/h = ? (in mL/min)

$$\left( \frac{2 \text{ gallons}}{\text{hour}} \right) \left( \frac{3.786 \text{ liter}}{1 \text{ gallon}} \right) \left( \frac{1000 \text{ mL}}{1 \text{ liter}} \right) \left( \frac{1 \text{ hour}}{60 \text{ min}} \right) = 126.2 \text{ mL/min}$$

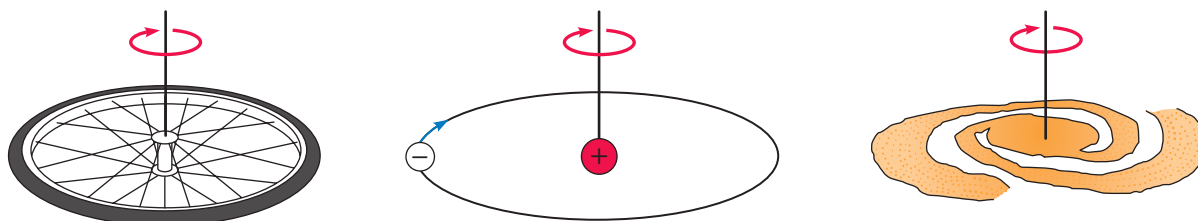
$$2 \text{ gallons/hour} = \mathbf{126.2 \text{ mL/min}}$$

Lines drawn through the units indicate cancellation.

Stating a result or prediction in numbers lends precision to otherwise vague claims. Measurement is an essential part of science and of everyday life. Using mathematical symbols and statements is an efficient way of stating the results of measurements and eases manipulating the relationships between quantities. Units of measurement are an essential part of any measurement, and the metric system of units used in most of the world has a number of advantages over the older English system.

## 1.5 Physics and Everyday Phenomena

Studying physics can and will lead us to ideas as earthshaking as the fundamental nature of matter and the structure of the universe. With ideas like these available, why spend time on more mundane matters like explaining how a bicycle stays upright or how a flashlight works? Why not just plunge into far-reaching discussions of the fundamental nature of reality?



**Figure 1.11** A bicycle wheel, a model of an atom, and a galaxy all involve the concept of angular momentum.

### Why study everyday phenomena?

Our understanding of the fundamental nature of the universe is based on concepts such as mass, energy, and electric charge that are abstract and not directly accessible to our senses. It is possible to learn some of the words associated with these concepts and to read and discuss ideas involving them without ever acquiring a good understanding of their meaning. This is one risk of playing with the grand ideas without laying the proper foundation.

Using everyday experience to raise questions, introduce concepts, and practice devising physical explanations has the advantage of dealing with examples that are familiar and concrete. These examples also appeal to your natural curiosity about how things work, which, in turn, can motivate you to understand the underlying concepts. If you can clearly describe and explain common events, you gain confidence in dealing with more abstract concepts. With familiar examples, the concepts are set on firmer ground, and their meaning becomes more real.

For example, why a bicycle (or a top) stays upright while moving but falls over when at rest involves the concept of angular momentum, which is discussed in chapter 8. Angular momentum also plays a role in our understanding of atoms and the atomic nucleus—both in the realm of the very small—and the structure of galaxies at the opposite end of the scale (fig. 1.11). You are more likely to understand angular momentum, though, by discussing it first in the context of bicycle wheels or tops.

The principles explaining falling bodies, such as the acorn mentioned in the chapter introduction, involve the concepts of velocity, acceleration, force, and mass, which are discussed in chapter 2, chapter 3, and chapter 4. Like angular momentum, these concepts are also important to

our understanding of atoms and the universe. Energy ideas, introduced initially in chapter 6, appear throughout the chapters that follow in the textbook. These ideas are crucial to the understanding of the universe, as well as to everyday concerns such as climate change and energy conservation.

Our “common sense” sometimes misleads us in our understanding of everyday phenomena. Adjusting common sense to incorporate well-established physical principles is one of the challenges we face in dealing with everyday experience. By performing simple experiments, either in laboratories and demonstrations associated with your course in physics or at home (as is often suggested in this book), you can take an active part in building your own scientific worldview.

Although it may seem like an oxymoron, everyday experience is extraordinary. A bright rainbow is an incredible sight. Understanding how rainbows originate does not detract from the experience. It adds excitement to explain such a beautiful display with just a few elegant concepts. In fact, people who understand these ideas see more rainbows because they know where to look. This excitement, and the added appreciation of nature that is a part of it, is accessible to all of us.

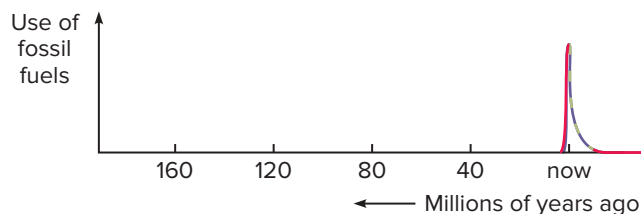
Studying everyday phenomena can make abstract ideas more accessible. These ideas are needed to understand the fundamental nature of matter and the universe, but they are best encountered first in familiar examples. Being able to explain common phenomena builds confidence in using the ideas and enhances our appreciation of what happens around us.

## Summary

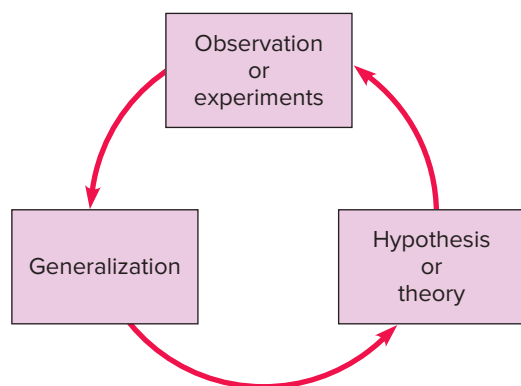
This first chapter introduces the connections between physics and everyday phenomena, including current issues involving energy. We also introduce the scientific enterprise and its methods, the scope of physics, and the use of mathematics and measurement in physics. The key points include the following:

**1 What about energy?** Most of our use of energy involves the burning of fossil fuels, which release carbon, and this affects many aspects of the Earth’s climate, including global warming. The definition and science of energy are in the realm of physics,

and therefore some understanding of this physics is crucial to meaningful participation in these debates.



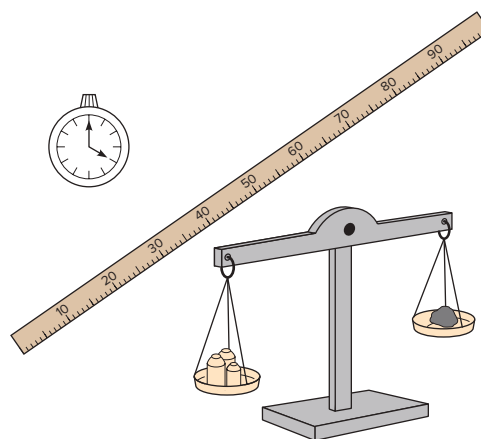
**2 The scientific enterprise.** Scientific explanations are developed by generalizing from observations of nature; forming hypotheses, or theories; and then testing these theories by further experiments or observations. This process is often called the *scientific method*, but actual practice may depart in various ways from this model.



**3 The scope of physics.** Physics is the most fundamental of the natural sciences, because physical theories often underlie explanations in the other sciences. Its major subfields include mechanics, thermodynamics, electricity and magnetism, optics, atomic physics, nuclear physics, condensed-matter physics, and particle physics.

**4 The role of measurement and mathematics in physics.** Much of the progress in physics can be attributed to its use of quantitative models, which yield precise predictions that can be tested by making physical measurements (with well-defined

units). Mathematics is a compact language for describing and manipulating these results. The basic concepts of physics can often be described and understood with a minimum of mathematics.



**5 Physics and everyday phenomena.** Many of the basic concepts of physics become clearer if applied to everyday phenomena. Being able to understand and explain familiar phenomena makes the concepts more vivid. This adds to the enjoyment of studying physics.



If you want an extra drill in doing algebraic manipulations of equations, or doing unit conversions, try the practice problems in Connect.

## Key Terms

Hypothesis, 4  
Theory, 5  
Scientific method, 5  
Empirical law, 5  
Classical physics, 8  
Modern physics, 8

Mechanics, 8  
Thermodynamics, 8  
Electricity and magnetism, 8  
Optics, 8  
Atomic physics, 8  
Nuclear physics, 8

Particle physics, 8  
Condensed-matter physics, 8  
Proportion, 10  
Metric system, 10  
Powers of 10, 12  
Scientific notation, 12

## Conceptual Questions

\* = more open-ended questions, requiring lengthier responses, suitable for group discussion

Q = sample responses are available in appendix D

Q = sample responses are available on Connect

Q1. Are fossil fuels produced within a few hundred years after dead plant remains are covered by dirt? Explain.

Q2. Do trees and other green plants have any impact on the amount of carbon dioxide in the atmosphere? Explain.

Q3. Since burning wood releases carbon dioxide to the atmosphere, should wood be considered a fossil fuel? Explain.

\*Q4. If the amount of carbon dioxide in the atmosphere is increasing with time, should we expect an increase in the average global temperature? Explain.

Q5. Has the burning of fossil fuels been taking place on a significant scale over many thousands of years? Explain.

Q6. Does the use of nuclear power significantly increase the amount of carbon dioxide in the atmosphere? Explain.

\*Q7. Which of these criteria best distinguish between explanations provided by science and those provided by religion: truth, testability, or appeal to authority? How do religious explanations differ from scientific explanations?

Q8. A person claiming to have paranormal powers states that she can predict which card will come up next in a shuffled deck of cards simply by exercising her mental powers. Is this a testable claim? Explain.

Q9. Historians sometimes develop theories to explain observed patterns in the history of different countries. Are these

- theories testable in the same sense as a theory in physics? Explain.
- \*Q10. Over the years, there have been several credible claims by experienced observers of sightings of unidentified flying objects (UFOs). Despite this, scientists have shied away from taking up a serious study of UFOs, although there are ongoing searches for signals from extraterrestrial intelligent beings. Can you think of reasons that scientists have not taken UFOs seriously? What problems can you see in trying to study UFOs?
- Q11. Suppose that your car will not start and you form the hypothesis that the battery is dead. How would you test this hypothesis? Explain. (See everyday phenomenon box 1.1.)
- Q12. Suppose that your phone has not rung in several days, but a friend tells you he has tried to call. Develop two hypotheses that could explain why the phone has not rung and state how you would test these hypotheses. (See everyday phenomenon box 1.1.)
- \*Q13. Suppose that a friend states the hypothesis that the color of socks that he wears on a given day, brown or black, will determine whether the stock market will go up or down. He can cite several instances in which this hypothesis has been apparently verified. How would you go about evaluating this hypothesis?
- Q14. Which of the three science fields—biology, chemistry, or physics—would you say is the most fundamental? Explain by describing in what sense one of these fields may be more fundamental than the others.
- Q15. Based on the brief descriptions provided in table 1.2, which subfield of physics would you say is involved in the explanation of rainbows? Which subfield is involved in describing how an acorn falls? Explain.
- Q16. Based on the descriptions provided in table 1.2, which subfields of physics are involved in explaining why an ice cube melts? Which subfields are involved in explaining how an airplane flies? Explain.
- Q17. Suppose you are told that speed is defined by the relationship  $s = d/t$ , where  $s$  represents speed,  $d$  represents distance, and  $t$  represents time. State this relationship in words, using no mathematical symbols.
- Q18. Impulse is defined as the average force acting on an object multiplied by the time the force acts. If we let  $I$  represent impulse,  $F$  the average force, and  $t$  the time, is  $I = F/t$  a correct way of expressing this definition? Explain.
- Q19. The distance that an object travels when it starts from rest and undergoes constant acceleration is one-half the acceleration multiplied by the square of the time. Invent your own symbols and express this statement in symbolic form.
- Q20. What are the primary advantages of the metric system of units over the older English system of units? Explain.
- Q21. What are the advantages, if any, of continuing to use the English system of units in industry and commerce rather than converting to the metric system? Explain.
- Q22. Which system of units, the metric system or English system, is used more widely throughout the world? Explain.
- Q23. The width of a man's hand was used as a common unit of length several hundred years ago. What are the advantages and disadvantages of using such a unit? Explain.
- Q24. A pirate map indicates that a treasure is buried 50 paces due east and 120 paces due north of a big rock. Will you know where to dig? Explain.
- Q25. List the following volumes in descending order: gallon, quart, liter, milliliter. The conversion factors given in appendix E may be useful.
- Q26. List the following lengths in descending order: kilometer, feet, mile, centimeter, inch. The conversion factors given in appendix E may be useful.

## Exercises

- E1. Suppose that a pancake recipe designed to feed five people calls for 310 grams of flour. How many grams of flour would you use if you wanted to reduce the recipe to only feed two people? (See everyday phenomenon box 1.2.)
- E2. Suppose that a cupcake recipe designed to produce 16 cupcakes calls for 240 grams of flour. How many grams of flour would you use if you wanted to make 20 cupcakes? (See everyday phenomenon box 1.2.)
- E3. It is estimated that eight medium pizzas are about right to serve a physics club meeting of 32 students. How many pizzas would be required if the group, due to a conflicting math club meeting, were only going to have 20 students in attendance? (See everyday phenomenon box 1.2.)
- E4. A child uses her hand to measure the width of a tabletop. If her hand has a width of 8 cm at its widest point, and she finds the tabletop to be 16.5 hands wide, what is the width of the tabletop in cm? In meters?
- E5. A small woman's foot is 7 inches long. If she steps off the length of a room by placing one foot directly in front of the other, and finds the room to be 15 foot-lengths long, what is the length of the room in inches? In feet?
- E6. A paperback book is 220 mm in height. What is this height in centimeters? In meters?
- E7. A crate has a mass of  $8.30 \times 10^6$  mg (milligrams). What is this mass in grams? In kilograms? (Hint: See table 1.3.)
- E8. A tank holds 5260 L (liters) of water. How many kiloliters is this? How many milliliters? (Hint: See table 1.3.)
- E9. A mile is 5280 ft long. The sample exercise in example box 1.2 shows that 1 foot is approximately 0.305 m. How many meters are in a mile? How many kilometers (km) are in a mile?
- E10. If a mile is 5280 ft long and a yard contains 3 ft, how many yards are in a mile?

- E11. Area is found by multiplying the length of a surface times the width. If a floor measures  $5.28 \text{ m}^2$ , how many square centimeters does this represent? How many square centimeters are in  $1 \text{ m}^2$ ?
- E12. A common speed limit in Vancouver, British Columbia, is  $70 \text{ km/h}$ . If you are going  $45 \text{ MPH}$ , are you speeding? Show by converting  $45 \text{ MPH}$  to  $\text{km/h}$  using the conversion factors in appendix E.
- E13. If gas costs  $\$1.27$  a liter, how much does a gallon of gas cost? Show by converting gallons to liters using the conversion factors in appendix E.
- E14. The volume of a cube is found by multiplying length times width times height. If an object has a volume of  $1.44 \text{ m}^3$ , what is the volume in cubic centimeters? Remember to multiply each side by the conversion factor.
- E15. If the area of a square has increased by a factor of 16, by how much has each side increased?
- E16. A cube has a certain volume. If the length of each side is tripled, by what factor will the volume increase?

## Synthesis Problems

- SP1. Astrologers claim that they can predict important events in your life by the configuration of the planets and the astrological sign under which you were born. Astrological predictions, called horoscopes, can be found in most daily newspapers. Find these predictions in a newspaper and address the questions:
- Are the astrological predictions testable?
  - Choosing the prediction for your own sign, how would you go about testing its accuracy over the next month or so?
  - Why do newspapers print these readings? What is their appeal?
- SP2. In the United States, a common quantity of hard liquor was historically a fifth, which represents a fifth of a U.S. gallon. However, because the United States wants to market its alcohol globally, and everyone else uses the metric system, it has retooled its packaging, so a common quantity is now  $750 \text{ mL}$ .
- How many liters are in a fifth?
  - How many milliliters are in a fifth?
  - Which is larger,  $750 \text{ mL}$  or a fifth of a gallon?
- SP3. A compact fluorescent light (CFL) bulb is very energy-efficient. A  $22\text{W}$  CFL bulb has the same brightness as a  $100\text{W}$  incandescent bulb. (Note that these calculations ignore the fact that the CFL bulb can last up to 10 times as long as the incandescent bulb. This would increase your savings even more.)
- If you have this lightbulb on for 5 hours a day, for 350 days during a year, how many hours is it on?
  - A kilowatt is 1000 watts. The kilowatt-hour is a common unit for energy, obtained by multiplying the power in kilowatts by the time used in hours. How many kilowatt-hours (kWh) will you use when burning the  $100\text{W}$  bulb for the year (don't forget to convert the  $100\text{W}$  to kW first)?
  - How many kilowatt-hours (kWh) will you use when burning the  $22\text{W}$  bulb for the year (be sure to convert the  $22\text{W}$  to kW before multiplying by the time in hours)?
  - Assuming that the cost of electricity is  $15\text{¢}$  per kWh, what is the cost of using the  $100\text{W}$  incandescent bulb for the year?
  - Assuming this same cost, what is the cost of using the  $22\text{W}$  CFL bulb for the year?
  - How much do you save per year by using the  $22\text{W}$  CFL bulb?
  - How much would you save every year if you replaced 20 of the  $100\text{W}$  incandescent bulbs with the  $22\text{W}$  CFL bulbs?

## Home Experiments and Observations

- HE1. Look around your house, car, or dormitory room to see what measuring tools (rulers, measuring cups, speedometers, etc.) you have handy. Which of these tools, if any, provides both English and metric units? For those that do, determine the conversion factor needed to convert the English units to metric units.
- HE2. Find 200 pennies (or other small, identical objects—cardboard squares will work). Create a square with 3 pennies in each of 3 rows. Represent the area as width  $\times$  length, or  $3 \times 3$  pennies, or 9 pennies.
- Double the number of pennies in each row and column. What is the area now? How much bigger is it than the original area? Is it twice as big? Is it four times as big?
  - Now double the number of pennies in each row and column once more. Can you correctly predict the area?
  - What is the pattern? If you started with a square with 2 pennies to the side, and you tripled the number of pennies in each row and column, how much greater would the area be? See if you can predict the answer before trying it.
  - Can you state the rule? If you multiply each side of an area by "n," by how much does the area increase, in terms of "n"?

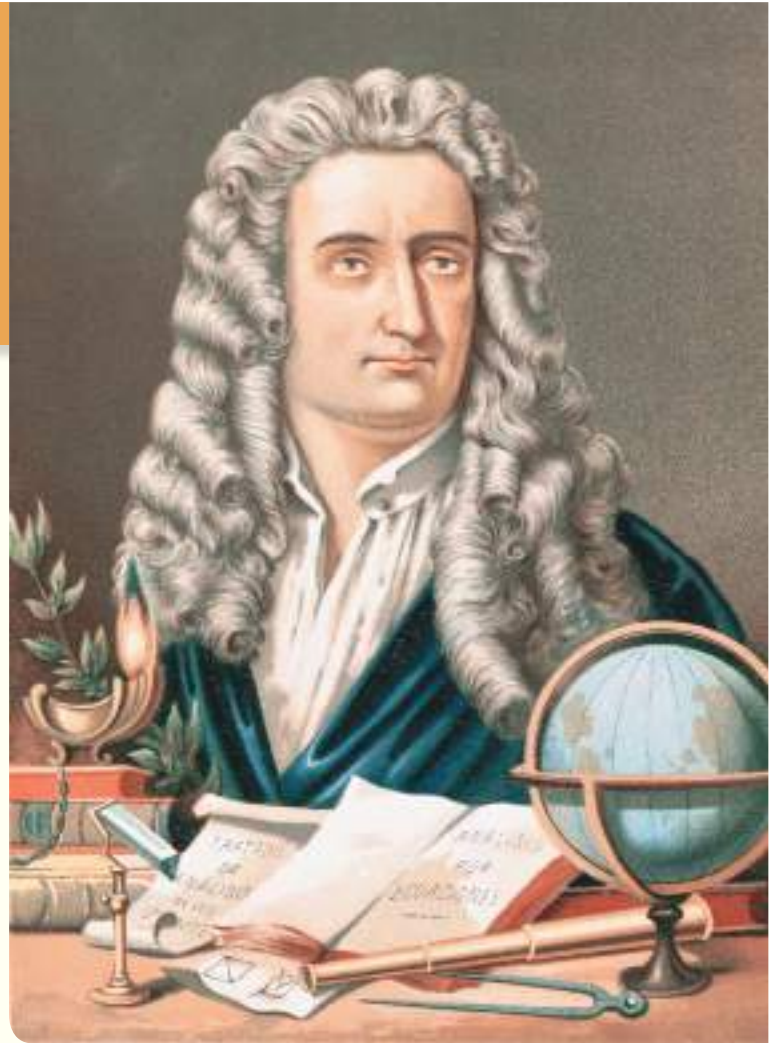
# UNIT 1

## The Newtonian Revolution

In 1687, Isaac Newton published his *Philosophiæ Naturalis Principia Mathematica*, or *Mathematical Principles of Natural Philosophy*. This treatise, often called simply Newton's *Principia*, presented his theory of motion, which included his three laws of motion and his law of universal gravitation. Together these *laws* explain most of what was then known about the motion of ordinary objects near Earth's surface (terrestrial mechanics), as well as the motion of the planets around the sun (celestial mechanics). Along the way, Newton had to invent the mathematical techniques that we call calculus.

Newton's theory of mechanics described in the *Principia* was an incredible intellectual achievement that revolutionized both science and philosophy. The revolution did not begin with Newton, though. The true rebel was Italian scientist Galileo Galilei, who died just a few months after Newton was born in 1642. Galileo championed the sun-centered view of the solar system proposed a hundred years earlier by Nicolaus Copernicus and stood trial under the Inquisition for his pains. Galileo also challenged the conventional wisdom, based on Aristotle's teachings, about the motion of ordinary objects. In the process, he developed many of the principles of terrestrial mechanics that Newton later incorporated into his theory.

Although Newton's theory of motion does not accurately describe the motion of very fast objects (which are now described using Einstein's theory of relativity) and very small objects (for which quantum mechanics must be used), it is still used extensively in physics and engineering to explain motion and to analyze structures. Newton's



Pixtal/age fotostock

theory has had enormous influence over the last three hundred years in realms of thought that extend well beyond the natural sciences and deserves to be understood by anyone claiming to be well educated.

Central to Newton's theory is his second law of motion. It states that the acceleration of an object is proportional to the net force acting on the object and inversely proportional to the mass of the object. Push an object and that object accelerates in the direction of the applied force. Contrary to intuition and to Aristotle's teachings, acceleration, not velocity, is proportional to the applied force. To understand this idea, we will thoroughly examine acceleration, which involves a *change* in the motion of an object.

Rather than plunging into Newton's theory, we begin this unit by studying Galileo's insights into motion and free fall. This provides the necessary foundation to tackle Newton's ideas. To see well, we need to stand on the shoulders of these giants.



Shutterstock/Lilian Liivaar

## Describing Motion

### Chapter Overview

The main purpose of this chapter is to provide clear definitions and illustrations of the terms used in physics to describe motion, such as the motion of the car described in this chapter's opening example. Speed, velocity, and acceleration are crucial concepts for the analysis of motion in later chapters. Precise description is the first step toward understanding. Without it, we remain awash in vague ideas that are not defined well enough to test our explanations.

Each numbered topic in this chapter builds on the previous section, so it is important to obtain a clear understanding of each topic before going on. The distinctions between speed and velocity and velocity and acceleration are particularly important.

### Chapter Outline

- 1 **Average and instantaneous speed.** How do we describe how fast an object is moving? How does instantaneous speed differ from average speed?
- 2 **Velocity.** How do we introduce direction into descriptions of motion? What is the distinction between speed and velocity?
- 3 **Acceleration.** How do we describe changes in motion? What is the relationship between velocity and acceleration?
- 4 **Graphing motion.** How can graphs be used to describe motion? How can the use of graphs help us gain a clearer understanding of speed, velocity, and acceleration?
- 5 **Uniform acceleration.** What happens when an object accelerates at a steady rate? How do the velocity and distance traveled vary with time when an object is uniformly accelerating?

Imagine that you are in your car, stopped at an intersection. After waiting for cross traffic, you pull away from the stop sign, accelerating eventually to a speed of 56 kilometers per hour (35 miles per hour). You maintain that speed until a dog runs in front of your car and you hit the brakes, reducing your speed rapidly to 10 km/h (fig. 2.1). Having missed the dog, you speed up again to 56 km/h. After another block, you come to another stop sign and reduce your speed gradually to zero.

We can all relate to this description. Measuring speed in miles per hour (MPH) may be more familiar than the use of kilometers per hour (km/h), but speedometers in cars now show both. The use of the term *acceleration* to describe an increase in speed is also common. In physics, however, these concepts take on more precise and specialized meanings that make them even more useful in describing exactly what

is happening. These meanings are sometimes different from those in everyday use. The term *acceleration*, for example, is used by physicists to describe any situation in which velocity is changing, even when the speed is decreasing or only the direction of the motion is changing.

How would you define the term *speed* if you were explaining the idea to a younger brother or sister? Does *velocity* mean the same thing? What about *acceleration*—is the notion vague or does it have a precise meaning? Is it the same thing as velocity? Clear definitions are essential to developing clear explanations. The language used by physicists differs from our everyday language, even though the ideas are related and the same words are used. What are the exact meanings that physicists attach to these concepts, and how can they help us to understand motion?



**Figure 2.1** As the car brakes for the dog, there is a sudden change in speed.

## 2.1 Average and Instantaneous Speed

Since driving or riding in cars is a common activity in our daily lives, we are familiar with the concept of speed. Most of us have had experience in reading a speedometer (or perhaps failing to read it carefully enough to avoid the attention of law enforcement). If you describe how fast something is moving, as we did in our example in the introduction, you are talking about **speed**.

### How is average speed defined?

What does it mean to say that we are traveling at a speed of 55 MPH? It means that we would cover a distance of 55 miles in a time of 1 hour if we traveled steadily at that speed. Carefully note the structure of this description: There is a number, 55, and some units or dimensions, miles per hour. Numbers and units are both essential parts of a description of speed.

The term *miles per hour* implies that miles are divided by hours in arriving at the speed. This is exactly how we would compute the **average speed** for a trip: Suppose, for example, that we travel a distance of 260 miles in a time of 5 hours, as

shown on the road map of figure 2.2. The average speed is then 260 miles divided by 5 hours, which is equal to 52 MPH. This type of computation is familiar to most of us.

We can also express the definition of average speed in a word equation as

Average speed equals the distance traveled divided by the time of travel.

or

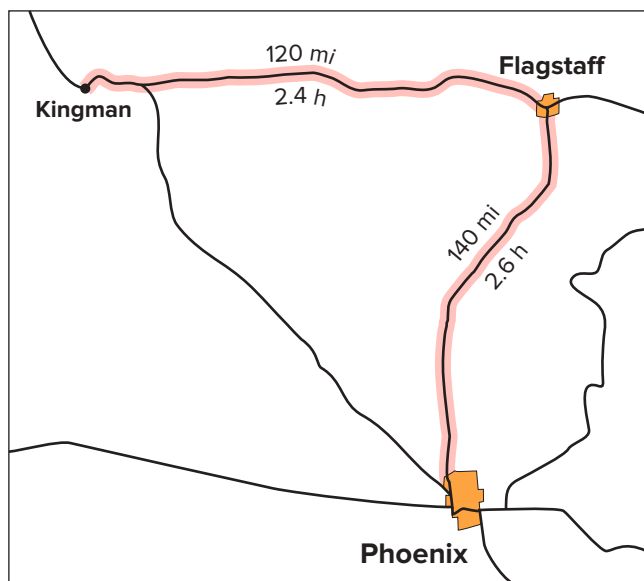
$$\text{Average speed} = \frac{\text{distance traveled}}{\text{time of travel}}$$

We can represent the same definition with symbols by writing

$$s = \frac{d}{t}$$

where the letter *s* represents the speed, *d* represents distance, and *t* represents the time. As noted in chapter 1, letters or





**Figure 2.2** A road map showing a trip of 260 miles, with driving times for the two legs of the trip.

symbols are a compact way of saying what could be said with words (and a little more effort and space). Judge for yourself which is the more efficient way of expressing this definition of average speed. Most people find the symbolic expression easier to remember and use.

The average speed that we have just defined is the **rate** at which distance is covered over time. Rates always represent one quantity divided by another. Gallons per minute, pesos per dollar, and points per game are all examples of rates. If we are considering time rates, the quantity that we divide by is *time*, which is the case with average speed. Many other quantities that we will be considering involve time rates.

### What are the units of speed?

Units are an essential part of the description of speed. Suppose you say that you were doing 70—without stating the units. In the United States, that would probably be understood as 70 MPH, because that is the unit most frequently used. In Europe, on the other hand, people would probably assume you were talking about the considerably slower speed of 70 km/h. If you do not state the units, you will not communicate effectively.

It is easy to convert from one unit to another if the conversion factors are known. For example, if we want to convert kilometers per hour to miles per hour, we need to know the relationship between miles and kilometers. A kilometer is roughly  $\frac{6}{10}$  of a mile (0.6214, to be more precise). As shown in example box 2.1, 90 km/h is equal to 55.9 MPH. The process involves multiplication or division by the appropriate conversion factor.

Units of speed will always be a distance divided by a time. In the metric system, the fundamental unit of speed is meters per second (m/s). Example box 2.1 also shows the

## Example Box 2.1

### Sample Exercise: Speed Conversions

Convert 90 kilometers per hour to (a) miles per hour and (b) meters per second.

- a. 1 km = 0.6214 miles  
90 km/h = ? (in MPH)

$$\left(\frac{90 \text{ km}}{\text{h}}\right)\left(\frac{0.6214 \text{ miles}}{\text{km}}\right) = 55.9 \text{ MPH}$$

$$90 \text{ km/h} = \mathbf{55.9 \text{ MPH}}$$

- b. 1 km = 1000 m

$$\left(\frac{90 \text{ km}}{\text{h}}\right)\left(\frac{1000 \text{ m}}{\text{km}}\right) = 90,000 \text{ m/h}$$

$$\text{However, } (1 \text{ h})\left(\frac{60 \text{ min}}{\text{h}}\right)\left(\frac{60 \text{ sec}}{\text{min}}\right) = 3600 \text{ s}$$

$$\left(\frac{90,000 \text{ m}}{\text{h}}\right)\left(\frac{1 \text{ h}}{3600 \text{ s}}\right) = 25.0 \text{ m/s}$$

$$90 \text{ km/h} = \mathbf{25.0 \text{ m/s}}$$

Part b can also be done using the conversion factors for speed in appendix E:

$$1 \text{ km/h} = 0.278 \text{ m/s}$$

$$(90 \text{ km/h})\left(\frac{0.278 \text{ m/s}}{1 \text{ km/h}}\right) = 25.0 \text{ m/s}$$

$$90 \text{ km/h} = \mathbf{25.0 \text{ m/s}}$$

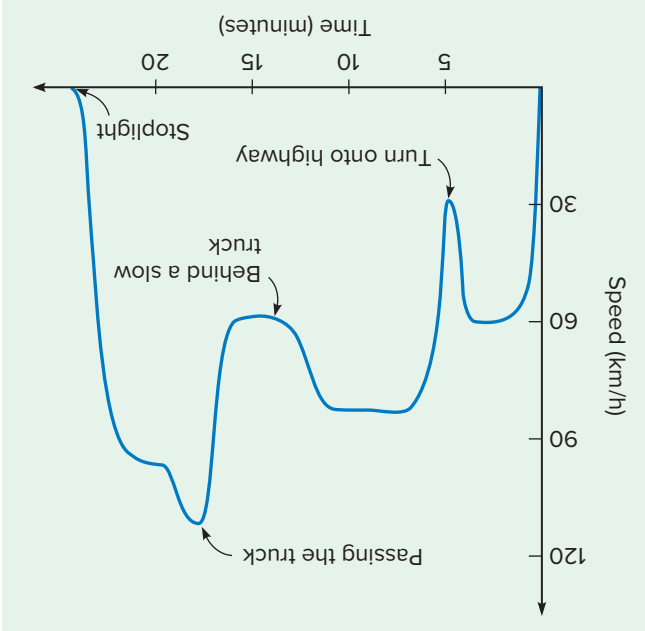
Lines drawn through the units indicate cancellation.

conversion of kilometers per hour to meters per second, done as a two-step process. As you can see, 90 km/h can also be expressed as 25.0 m/s. This is a convenient size for discussing the speeds of ordinary objects. (As shown in example box 2.2, the convenient unit for measuring the growth of grass has a very different size.) Table 2.1 shows some familiar speeds expressed in miles per hour, kilometers per hour, and meters per second to give you a sense of their relationships.

**Table 2.1**

Familiar Speeds in Different Units

20 MPH	=	32 km/h	=	9 m/s
40 MPH	=	64 km/h	=	18 m/s
60 MPH	=	97 km/h	=	27 m/s
80 MPH	=	130 km/h	=	36 m/s
100 MPH	=	160 km/h	=	45 m/s



**Figure 2.4** Variations in instantaneous speed for a portion of a trip on a local highway.

Even though we all have some intuitive sense of what instantaneous speed means from our experience in reading speedometers, computing this quantity presents some problems that we did not encounter in defining average speed. We could say that instantaneous speed is the rate that distance is being covered at a given instant in time, but how do we compute this rate? What time interval should we use? What is an instant in time?

Our solution to this problem is simply to choose a very short interval of time during which a very short distance is covered and the speed does not change drastically. If we know, for example, that in 1 second a distance of 20 meters was covered, dividing 20 meters by 1 second to obtain a speed of 20 m/s would give us a good estimate of the instantaneous speed, provided that the speed did not change much during that single second. If the speed was changing rapidly, we would have to choose an even shorter interval of time. In principle, we can choose time intervals as small as we wish, but in practice it can be hard to measure such small quantities. If we put these ideas into a word definition of instantaneous speed, we could state it as

Instantaneous speed is the rate at which distance is being covered at a given instant in time. It is found by computing the average speed for a very short time interval in which the speed does not change appreciably.

Instantaneous speed is closely related to the concept of average speed but involves very short time intervals. When discussing traffic flow, average speed is the critical issue, as shown in everyday phenomenon box 2.1.

## Example Box 2.2

### Sample Question: Watching Grass Grow

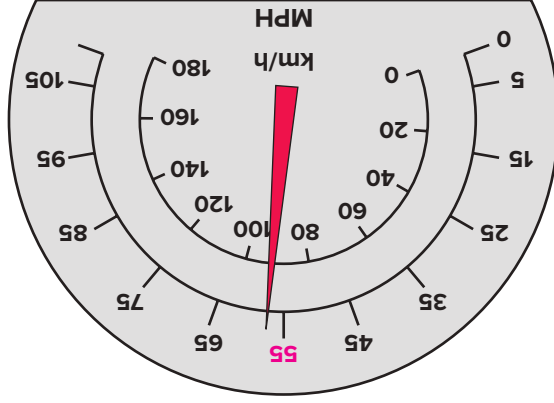
**Question:** The units km/h and m/s have an appropriate size for moving cars and people. Many other processes move much more slowly, though. What units would have an appropriate size for measuring the average speed with which a blade of grass grows?

**Answer:** When grass is well fertilized and watered, it is not unusual for it to grow 3 to 6 centimeters in the course of a week. This can be seen by measuring the length of the clippings after mowing. If we measured the speed in m/s, we would obtain an extremely small number that would not provide a good intuitive sense of the rate of growth. The units of cm/week and mm/day would provide a better indication of this speed.

### What is instantaneous speed?

If we travel a distance of 260 miles in 5 hours, as in our earlier example, is it likely that the entire trip takes place at a speed of 52 MPH? Of course not; the speed goes up and down as the road goes up and down, when we overtake slower vehicles, when rest breaks occur, or when the highway patrol looms on the horizon. If we want to know how fast we are going at a given instant in time, we read the speedometer, which displays the **instantaneous speed** (Fig. 2.3).

How does instantaneous speed differ from average speed? The instantaneous speed tells us how fast we are going at a given instant but tells us little about how long it will take to travel several miles, unless the speed is held constant. The average speed, on the other hand, allows us to compute how long a trip might take but says little about the variation in speed during the trip. A more complete description of how the speed of a car varies during a trip could be provided by a graph such as that shown in Figure 2.4. Each point on this graph represents the instantaneous speed at the time indicated on the horizontal axis.



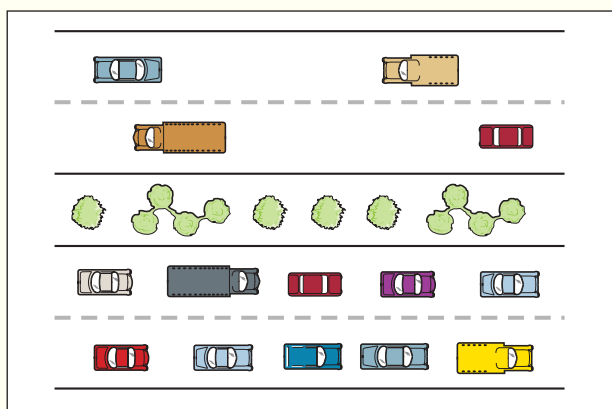
**Figure 2.3** A speedometer with two scales for measuring instantaneous speed: MPH and km/h.

## Everyday Phenomenon

## Box 2.1

## Transitions in Traffic Flow

**The Situation.** Jennifer commutes into the city on a freeway every day for work. As she approaches the city, the same patterns in traffic flow seem to show up in the same places each day. She will be moving with the flow of traffic at a speed of approximately 60 MPH when suddenly things will come to a screeching halt. The traffic will be stop-and-go briefly and then will settle into a wavelike mode, with speeds varying between 10 and 30 MPH. Unless there is an accident, this will continue for the rest of the way into the city.



The traffic in the upper lanes is flowing freely with adequate spacing to allow higher speeds. The higher-density traffic in the lower lanes moves much more slowly.

What causes these patterns? Why does the traffic stop when there is no apparent reason such as an accident? Why do ramp traffic lights seem to help the situation? Questions like these are the concern of the growing field of traffic engineering.

**The Analysis.** Although a full analysis of traffic flow is complex, there are some simple ideas that can explain many of the patterns that Jennifer observes. The density of vehicles, measured in vehicles per mile, is a key factor. Adding vehicles at entrance ramps increases this vehicle density.

When Jennifer and other commuters are traveling at 60 MPH, they need to keep a spacing of several car lengths between vehicles. Most drivers do this without thinking about it, although there are always some who follow too closely, or *tailgate*. Tailgating runs the risk of rear-end collisions when the traffic suddenly slows. Reaction time, and its implications for tailgating, is discussed in everyday phenomenon box 3.1.

When more vehicles are added at an entrance ramp, the density of vehicles increases, reducing the distance between vehicles. As the distance between vehicles decreases, drivers should reduce their speed to maintain a safe stopping distance. If this occurred uniformly, there would be a gradual decrease in

the average speed of the traffic to accommodate the greater density. This is not what usually happens, however.

A significant proportion of drivers will attempt to maintain their speed at 50 to 60 MPH, even when densities have increased beyond the point where this is advisable. This creates an unstable situation. At some point, usually near an entrance ramp, the vehicle density becomes too large to sustain these speeds. At this point, there is a sudden drop in average speed and a large increase in the local density. As shown in the drawing, cars can be separated by less than a car length when they are stopped or moving very slowly.

Once the average speed of a few vehicles has slowed to less than 10 MPH, vehicles moving at 50 to 60 MPH begin to pile up behind this slower-moving jam. Because this does not happen smoothly, some vehicles must come to a complete stop, further slowing the flow. At the front end of the jam, on the other hand, the density is reduced due to the slower flow behind. Cars can then start moving at a speed consistent with the new density, perhaps around 30 MPH. If every vehicle moved with the appropriate speed, flow would be smooth and the increased density could be safely accommodated. More often, however, overanxious drivers exceed the appropriate speed, causing fluctuations in the average speed as vehicles begin to pile up again.

Notice that we are using *average speed* with two different meanings in this discussion. One is the average speed of an individual vehicle as its instantaneous speed increases and decreases. The other is the average speed of the overall traffic flow involving many vehicles. When the traffic is flowing freely, the average speed of different vehicles may differ. When the traffic is in a slowly moving jam, the average speeds of different vehicles are essentially the same, at least within a given lane.

Traffic lights at entrance ramps that permit vehicles to enter one-at-a-time at appropriate intervals can help to smoothly integrate the added vehicles to the existing flow. This reduces the sudden changes in speed caused by a rapid increase in density. Once the density increases beyond the certain level, however, a slowing of traffic is inevitable. The abrupt change from low-density, high-speed flow to higher-density, slow flow is analogous to a phase transition from a gas to a liquid. (Phase transitions are discussed in chapter 10.) Traffic engineers have used this analogy to better understand the process.

If we could automatically control and coordinate the speeds of all the vehicles on the highway, the highway could carry a much greater volume of traffic at a smooth rate of flow. Speeds could be adjusted to accommodate changes in density, and smaller vehicle separations could be maintained at higher speeds, because all the vehicles would be moving in a synchronized fashion. Better technology may someday achieve this dream.

We find an average speed by dividing the distance traveled by the time required to cover that distance. Average speed is therefore the average rate at which distance is being covered. Instantaneous speed is the rate that distance is being covered at a given instant in time and is found by considering very small time intervals or by reading a speedometer. Average speed is useful for estimating how long a trip will take, but instantaneous speed is of more interest to the highway patrol.

### Debatable Issue

A radar gun used by a police officer measures your speed at a certain instant in time, whereas an officer in a plane measures the time it takes for you to travel the known distance between two stripes painted on the highway. What is the difference in nature between these two types of measurement and which is the fairer basis for issuing a speeding ticket?

## 2.2 Velocity

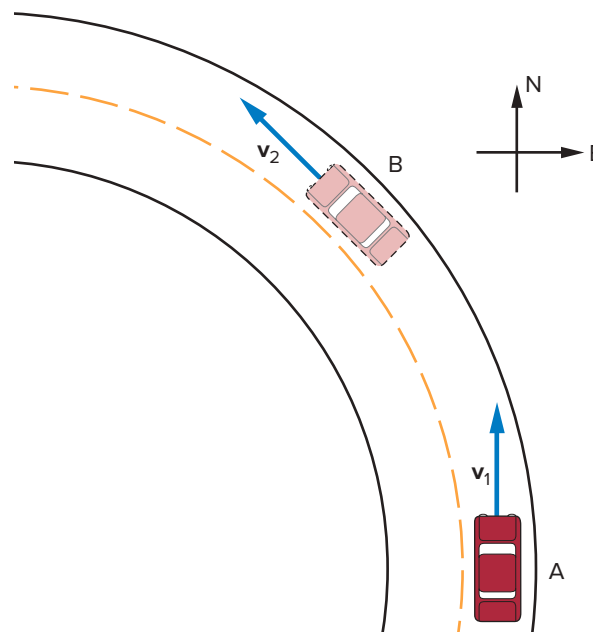
Do the words *speed* and *velocity* mean the same thing? They are often used interchangeably in everyday language, but physicists make an important distinction between the two terms. The distinction has to do with direction: Which way is the object moving? This distinction turns out to be essential to understanding Newton's theory of motion (introduced in chapter 4), so it is not just a matter of whim or jargon.

### What is the difference between speed and velocity?

Imagine you are driving a car around a curve (as illustrated in fig. 2.5) and you maintain a constant speed of 60 km/h. Is your velocity also constant in this case? The answer is no, because **velocity** involves the direction of motion, as well as how fast the object is going. The direction of motion is changing as the car goes around the curve.

To simply state this distinction, speed as we have defined it tells us how fast an object is moving but says nothing about the direction of the motion. Velocity includes the idea of direction. To specify a velocity, we must give both its size or **magnitude** (how fast) and its direction (north, south, east, up, down, or somewhere in between). If you tell me that an object is moving 15 m/s, you have told me its *speed*. If you tell me that it is moving due west at 15 m/s, you have told me its *velocity*.

At point A on the diagram in figure 2.5, the car is traveling due north at 60 km/h. At point B, because the road curves, the car is traveling northwest at 60 km/h. Its velocity at point B is different from its velocity at point A (because the directions are different). The speeds at points A and B are the same.







**Figure 2.5** The direction of the velocity changes as the car moves around the curve, so that the velocity  $v_2$  is not the same as the velocity  $v_1$  even though the speed has not changed.

Direction is irrelevant in specifying the speed of the object. It has no effect on the reading on your speedometer.

Changes in velocity are produced by forces acting upon the car, as we will discuss further in chapter 4. The most important force involved in changing the velocity of a car is the frictional force exerted on the tires of the car by the road surface. A force is required to change either the size or the direction of the velocity. If no net force were acting on the car, it would continue to move at constant speed in a straight line. This happens sometimes when there is ice or oil on the road surface, which can reduce the frictional force to almost zero.

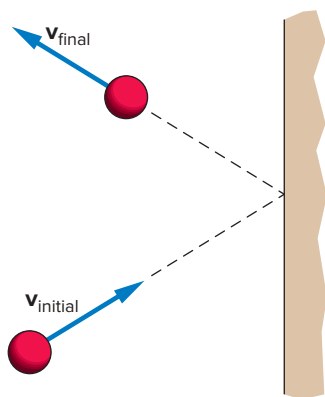
### Study Hint

Science has always relied on pictures and charts to get points across. Throughout the book, a number of concepts will be introduced and illustrated. In the illustrations, the same color will be used for certain phenomena.

-  Blue arrows are velocity vectors.
-  Green arrows depict acceleration vectors.
-  Red arrows depict force vectors.
-  Purple arrows show momentum, a concept we will explore in chapter 7.

### What is a vector?

Velocity is a quantity for which both the size and direction are important. We call such quantities **vectors**. To describe



**Figure 2.6** The direction of the velocity changes when a ball bounces from a wall. The wall exerts a force on the ball in order to produce this change.

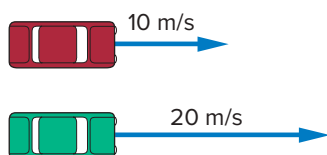
these quantities fully, we need to state *both the size and the direction*. Velocity is a vector that describes how fast an object is moving and in what direction it is moving. Many of the quantities used in describing motion (and in physics more generally) are **vector quantities**. These include velocity, acceleration, force, and momentum.

Think about what happens when you throw a rubber ball against a wall, as shown in figure 2.6. The speed of the ball may be about the same after the collision with the wall as it was before the ball hit the wall. The velocity has clearly changed in the process, though, because the ball is moving in a different direction after the collision. Something has happened to the motion of the ball. A strong force had to be exerted on the ball by the wall to produce this change in velocity.

The velocity vectors in figures 2.5 and 2.6 are represented by arrows. This is a natural choice for depicting vectors, because the direction of the arrow clearly shows the direction of the vector, and the length can be drawn proportional to the size. In other words, the larger the velocity, the longer the arrow (fig. 2.7). In the text, we will represent vectors by printing their symbols in boldface and making them larger than other symbols:  $\mathbf{v}$  is thus the symbol for velocity. A fuller description of vectors can be found in appendix C.

### How do we define instantaneous velocity?

In considering automobile trips, *average* speed is the most useful quantity. We do not really care about the direction of motion in this case. *Instantaneous* speed is the quantity of



**Figure 2.7** The length of the arrows show the relative size of the velocity vectors.

interest to the highway patrol. **Instantaneous velocity**, however, is most useful in considering physical theories of motion. We can define instantaneous velocity by drawing on our earlier definition of instantaneous speed.

Instantaneous velocity is a vector quantity having a size equal to the instantaneous speed at a given instant in time and having a direction corresponding to that of the object's motion at that instant.

Instantaneous velocity and instantaneous speed are closely related, but velocity includes direction as well as size. It is *changes* in instantaneous velocity that require the intervention of forces. These changes will be emphasized when we explore Newton's theory of mechanics in chapter 4. We can also define the concept of average velocity, but that is a much less useful quantity for our purposes than either instantaneous velocity or average speed.\*

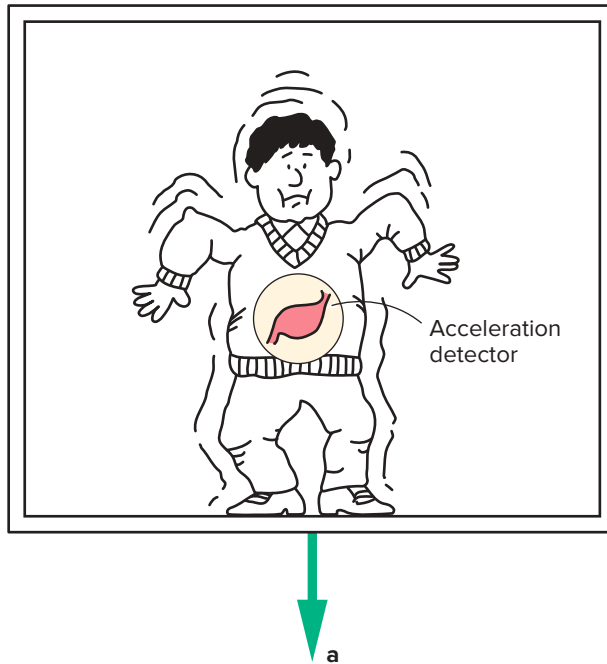
To specify the velocity of an object, we need to state both how fast and in what direction the object is moving; velocity is a vector quantity. Instantaneous velocity has a magnitude equal to the instantaneous speed, and it points in the direction that the object is moving. Changes in instantaneous velocity are where the action is, so to speak, and we will consider these in more detail when we discuss acceleration in section 2.3.

## 2.3 Acceleration

Acceleration is a familiar idea. We use the term in speaking of the acceleration of a car away from a stop sign or the acceleration of a running back in football. We feel the effects of acceleration on our bodies when a car's velocity changes rapidly and even more strikingly when an elevator lurches downward, leaving our stomachs slightly behind (fig. 2.8). These are all accelerations. You can think of your stomach as an acceleration detector—a roller coaster gives it a real workout!

Understanding acceleration is crucial to our study of motion. **Acceleration** is the rate at which velocity *changes*. (Note that we said velocity, not speed.) It plays a central role in Newton's theory of motion. How do we go about finding

\*Strictly speaking, velocity is the change in displacement divided by time, where displacement is a vector representing the change in position of an object. See appendix C and figure C.2 for a discussion of displacement vectors. In one-dimensional motion when an object does not change direction, the distance traveled is equal to the magnitude of the displacement.



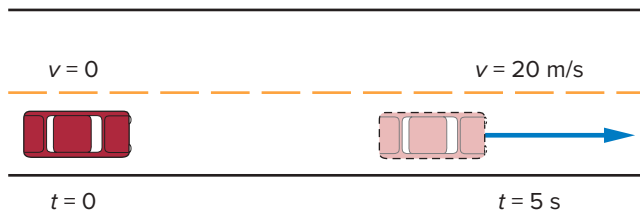
**Figure 2.8** Your acceleration detector senses the downward acceleration of the elevator.

a value of an acceleration, though? As with speed, it is convenient to start with a definition of average acceleration and then extend it to the idea of instantaneous acceleration.

### How is average acceleration defined?

How would we go about providing a quantitative description of an acceleration? Suppose that your car, pointing due east, starts from a full stop at a stop sign, and its velocity increases from zero to 20 m/s, as shown in figure 2.9. The change in velocity is found simply by subtracting the initial velocity from the final velocity ( $20 \text{ m/s} - 0 \text{ m/s} = 20 \text{ m/s}$ ). To find its *rate of change*, however, we also need to know the time needed to produce this change. If it took just 5 seconds for the velocity to change, the rate of change would be larger than if it took 30 seconds.

Suppose that a time of 5 seconds was required to produce this change in velocity. The rate of change in velocity could then be found by dividing the size of the change in velocity by the time required to produce that change. Thus, the size



**Figure 2.9** A car, starting from rest, accelerates to a velocity of 20 m/s due east in a time of 5 s.

of the **average acceleration**,  $a$ , is found by dividing the change in velocity of 20 m/s by the time of 5 seconds,

$$a = \frac{20 \text{ m/s}}{5 \text{ s}} = 4 \text{ m/s/s}$$

The unit m/s/s is usually written  $\text{m/s}^2$  and is read as *meters per second squared*. It is easier to understand it, however, as *meters per second per second*. The car's velocity (measured in m/s) is changing at a rate of 4 m/s every second. Other units could be used for acceleration, but they will all have this same form: distance per unit of time per unit of time. In discussing the acceleration of a car on a drag strip, for example, the unit *miles per hour per second* is sometimes used.

The quantity we have just computed is the size of the average acceleration of the car. The average acceleration is found by dividing the total change in velocity for some time interval by that time interval, ignoring possible differences in the rate of change of velocity that might be occurring within the time interval. Its definition can be stated in words as follows:

Average acceleration is the change in velocity divided by the time required to produce that change.

We can restate it in symbols as

$$\text{Acceleration} = \frac{\text{change in velocity}}{\text{elapsed time}}$$

or

$$\mathbf{a} = \frac{\Delta \mathbf{v}}{t}$$

Because change is so important in this definition, we have used the special symbol  $\Delta$  (the Greek letter delta) to mean a change in a quantity. Thus,  $\Delta \mathbf{v}$  is a compact way of writing *the change in velocity*, which otherwise could be expressed as  $\mathbf{v}_f - \mathbf{v}_i$ , where  $\mathbf{v}_f$  is the final velocity and  $\mathbf{v}_i$  is the initial velocity. Because the concept of change is critical, this delta ( $\Delta$ ) notation will appear often.

The idea of change is all-important. Acceleration is *not* velocity over time. It is the *change* in velocity divided by time. It is common for people to associate large accelerations with large velocities when, in fact, the opposite is often true. The acceleration of a car may be largest, for example, when it is just starting up and its velocity is near zero. The rate of change of velocity is greatest then. On the other hand, a car can be traveling at 100 MPH but still have a zero acceleration if its velocity is not changing.

### What is instantaneous acceleration?

**Instantaneous acceleration** is similar to average acceleration, with an important exception. Just as with instantaneous speed or velocity, we are now concerned with the rate of

change at a given instant in time. It is *instantaneous* acceleration that our stomachs respond to. It can be defined as follows:

Instantaneous acceleration is the rate at which velocity is changing at a given instant in time. It is computed by finding the average acceleration for a very short time interval during which the acceleration does not change appreciably.

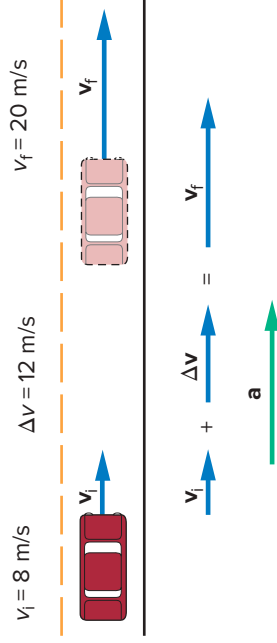
If the acceleration is changing with time, choosing a very short time interval guarantees that the acceleration computed for that time interval will not differ too much from the instantaneous acceleration at any time within the interval. This is the same idea used in finding an instantaneous speed or instantaneous velocity.

### What is the direction of an acceleration?

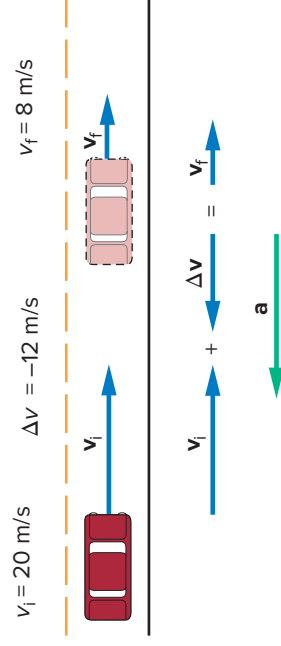
Like velocity, acceleration is a vector quantity. Its direction is important. The direction of the acceleration vector is that of the *change* in velocity  $\Delta v$ . If, for example, a car is moving in a straight line and its velocity is increasing, the change in velocity is in the same direction as the velocity itself, as shown in figure 2.10. The change in velocity  $\Delta v$  must be added to the initial velocity  $v_i$  to obtain the final velocity  $v_f$ . All three vectors point forward. The process of adding vectors can be readily seen when we represent the vectors as arrows on a graph. (More information on vector addition can be found in appendix C.)

If the velocity is decreasing, however, the change in velocity  $\Delta v$  points in the opposite direction to the two velocity vectors, as shown in figure 2.11. Because the initial velocity  $v_i$  is larger than the final velocity  $v_f$ , the change in velocity must point in the opposite direction to produce a shorter  $v_f$  arrow. The acceleration is also in the opposite direction to the velocity, because it is in the direction of the *change* in velocity.

In Newton's theory of motion (chapter 4), the force required to produce this acceleration would also be opposite in direction to the velocity. It must push backward on the car to slow it down. In general, if an object's velocity is decreasing, velocity and acceleration vectors point in opposite directions and therefore have opposite signs. If an object is speeding up, the signs of the velocity and acceleration are the same.



**Figure 2.10** The acceleration vector is in the same direction as the velocity vectors when the velocity is increasing.



**Figure 2.11** The velocity and acceleration vectors for decreasing velocity:  $\Delta v$  and  $a$  are now opposite in direction to the velocity. The acceleration  $a$  is proportional to  $\Delta v$ .

The term *acceleration* describes the rate of *any* change in an object's velocity. The change could be an increase (as in our initial example), a decrease, or a change in direction. The term applies even to decreases in velocity (*decelerations*). To a physicist these are simply accelerations with a direction opposite that of the velocity. If a car is braking while traveling in a straight line, its velocity is decreasing and its acceleration is negative if the velocity is positive. This situation is illustrated in the sample exercise in example box 2.3. If, on the other hand, the car is moving in the negative direction and slowing down, the acceleration is in the positive direction. When an object is slowing down, the velocity and acceleration vectors point in opposite directions.

The minus sign is an important part of the result in the example in example box 2.3, because it indicates that the change in velocity is negative. The velocity is getting smaller. We can call it a deceleration if we like, but it is the same thing as a negative acceleration. One word, *acceleration*, covers all situations in which the velocity is changing.

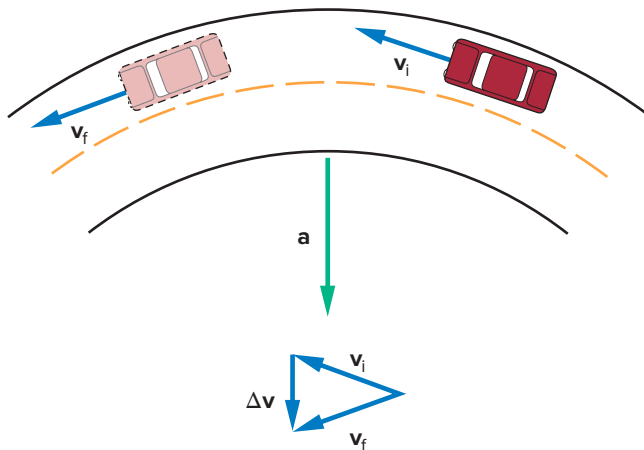
## Example Box 2.3

### Sample Exercise: Negative Accelerations

The driver of a car steps on the brakes, and the velocity drops from 30 m/s due east to 10 m/s due east in a time of 4.0 seconds. What is the acceleration?

$$\begin{aligned}
 v_i &= 30 \text{ m/s due east} & a &= \frac{\Delta v}{t} = \frac{v_f - v_i}{t} \\
 v_f &= 10 \text{ m/s due east} & &= \frac{10 \text{ m/s} - 30 \text{ m/s}}{4.0 \text{ s}} \\
 t &= 4.0 \text{ s} & &= \frac{-20 \text{ m/s}}{4.0 \text{ s}} \\
 a &=? & &= -5 \text{ m/s}^2 \\
 & & &= -5 \text{ m/s}^2 \text{ due west}
 \end{aligned}$$

Notice that when we are dealing just with the magnitude of a vector quantity, we do not use the boldface notation. The sign can indicate direction, however, in a problem involving straight-line motion.



**Figure 2.12** A change in the direction of the velocity vector also involves an acceleration, even though the speed may be constant.

### Can a car be accelerating when its speed is constant?

What happens when a car goes around a curve at constant speed? Is it accelerating? The answer is yes, because the direction of its velocity is changing. If the direction of the velocity vector is changing, the velocity is changing. This means there must be an acceleration.

This situation is illustrated in figure 2.12. The arrows in this drawing show the direction of the velocity vector at different points in the motion. The change in velocity  $\Delta\mathbf{v}$  is the vector that must be added to the initial velocity  $\mathbf{v}_i$  to obtain the final velocity  $\mathbf{v}_f$ . The vector representing the change in velocity points toward the center of the curve, and therefore the acceleration vector also points in that direction. The size of the change is represented by the length of the arrow  $\Delta\mathbf{v}$ . From this, we can find the acceleration.

Acceleration is involved whenever there is a change in velocity, regardless of the nature of that change. Cases like figure 2.12 will be considered more fully in chapter 5, where circular motion is discussed.

Acceleration is the rate of change of velocity and is found by dividing the change in the velocity by the time required to produce that change. Any change in velocity involves an acceleration, whether an increase or a decrease in speed, or a change in direction. Acceleration is a vector having a direction corresponding to the direction of the change in velocity, which is not necessarily the same direction as the instantaneous velocity itself. The concept of change is crucial. The graphical representations in section 2.4 will help you visualize changes in velocity as well as changes in other quantities.

## 2.4 Graphing Motion

It is often said that a picture is worth a thousand words, and the same can be said of graphs. Imagine trying to describe the motion depicted in figure 2.4 precisely in words and numbers. The graph provides a quick overview of what took place. A description in words would be much less efficient. In this section, we will show how graphs can also help us to understand velocity and acceleration.

### What can a graph tell us?

How can we produce and use graphs to help us describe motion? Imagine you are watching a battery-powered toy car moving along a meter stick (fig. 2.13). If the car were moving slowly enough, you could record the car's position while also recording the elapsed time using a digital watch. At regular time intervals (say, every 5 seconds), you would note the value of the position of the front of the car on the meter stick and write down these values. The results would be something like those shown in table 2.2.

How do we graph these data? First, we create evenly spaced intervals on each of two perpendicular axes, one for distance traveled (or position) and the other for time. To show how distance varies with time, we usually put time on the horizontal axis and distance on the vertical axis. Such a graph is shown in figure 2.14, where each data point from table 2.2 is plotted and a line is drawn through the points. To make sure you understand this process, choose different points from table 2.2 and find where they are located on the graph. Where would the point go if the car were at 21 centimeters at 25 seconds?

The graph summarizes the information presented in the table in a visual format that makes it easier to grasp at a glance. The graph also contains information on the velocity and acceleration of the car, although that is less obvious.



**Figure 2.13** A toy car moving along a meter stick. Its position can be recorded at different times.

*Michelle Mauser/McGraw-Hill Education*



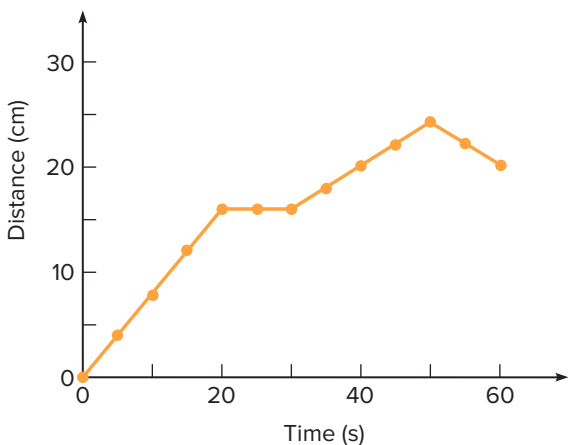
**Table 2.2**

Position of the Toy Car along the Meter Stick at Different Times

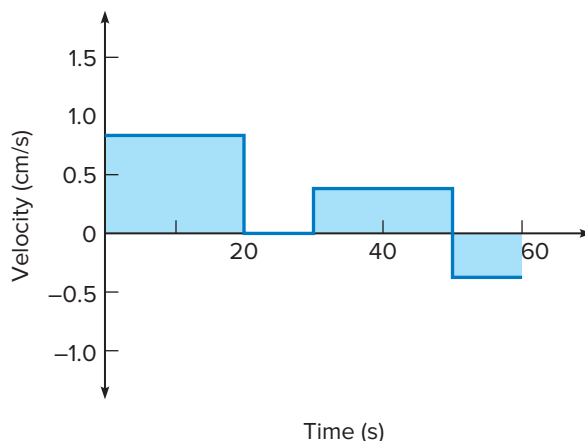
Time	Position
0 s	0 cm
5 s	4.1 cm
10 s	7.9 cm
15 s	12.1 cm
20 s	16.0 cm
25 s	16.0 cm
30 s	16.0 cm
35 s	18.0 cm
40 s	20.1 cm
45 s	21.9 cm
50 s	24.0 cm
55 s	22.1 cm
60 s	20.0 cm

For example, what can we say about the average velocity of the car between 20 and 30 seconds? Is the car moving during this time? A glance at the graph shows us that the distance is not changing during that time interval, so the car is *not* moving. The velocity is zero during that time, which is represented by a horizontal line on our graph of distance versus time.

What about the velocity at other points in the motion? The car is moving more rapidly between 0 and 20 seconds than it is between 30 and 50 seconds. The distance curve is rising more rapidly between 0 and 20 seconds than between 30 and 50 seconds. Because more distance is covered in the same time, the car must be moving faster there. A steeper slope to the curve is associated with a larger speed.



**Figure 2.14** Distance plotted against time for the motion of the toy car. The data points are those listed in table 2.2.



**Figure 2.15** Instantaneous velocity plotted against time for the motion of the toy car. The velocity is greatest when distance traveled is changing most rapidly.

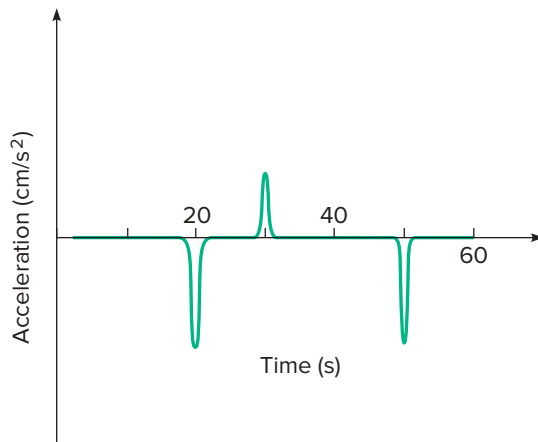
In fact, the **slope** of the distance-versus-time curve at any point on the graph is equal to the *instantaneous velocity* of the car.\* The slope indicates how rapidly the distance is changing with time at any instant in time. The rate of change of distance with time is the instantaneous speed according to the definition given in section 2.1. Because the motion takes place along a straight line, we can then represent the direction of the velocity with plus or minus signs. There are only two possibilities, forward or backward. We then have the instantaneous velocity, which includes both the size (speed) and direction of the motion.

When the car travels backward, its distance from the starting point decreases. The curve goes down, as it does between 50 and 60 seconds. We refer to this downward-sloping portion of the curve as having a *negative slope* and say that the velocity is negative during this portion of the motion. A large upward slope represents a large instantaneous velocity, a zero slope (horizontal line) a zero velocity, and a downward slope a negative (backward) velocity. Looking at the slope of the graph tells us all we need to know about the velocity of the car.

### Velocity and acceleration graphs

These ideas about velocity can be best summarized by plotting a graph of velocity against time for the car (fig. 2.15). The velocity is constant wherever the *slope* of the distance-versus-time graph of figure 2.14 is constant. Any straight-line segment of a graph has a constant slope, so the velocity

\*Because the mathematical definition of slope is the change in the vertical coordinate  $\Delta d$  divided by the change in the horizontal coordinate  $\Delta t$ , the slope,  $\Delta d/\Delta t$ , is equal to the instantaneous velocity, provided that  $\Delta t$  is sufficiently small. It is possible to grasp the concept of slope, however, without appealing to the mathematical definition.



**Figure 2.16** An approximate sketch of acceleration plotted against time for the toy-car data. The acceleration is nonzero only when the velocity is changing.

changes only where the slope of the distance graph in figure 2.14 changes. If you carefully compare the graph in figure 2.15 to the graph in figure 2.14, these ideas should become clear.

What can we say about the acceleration from these graphs? Because acceleration is the rate of change of velocity with time, the velocity graph (fig. 2.15) also provides information about the acceleration. In fact, the instantaneous acceleration is equal to the slope of the velocity-versus-time graph. A steep slope represents a rapid change in velocity and thus a large acceleration. A horizontal line has zero slope and represents zero acceleration. The acceleration turns out to be zero for most of the motion described by our data. The velocity changes at only a few points in the motion. The acceleration would be large at these points and zero everywhere else.

Because our data do not indicate how rapidly the changes in velocity actually occur, we do not have enough information to say just how large the acceleration is at those few points where it is not zero. We would need measurements of distance or velocity every tenth of a second or so to get a clear idea of how rapid these changes are. As we will see in chapter 4, we know that these changes in velocity cannot occur instantly. Some time is required. Thus, we can sketch an approximate graph of acceleration versus time, as shown in figure 2.16.

The spikes in figure 2.16 occur when the velocity is changing. At 20 seconds, there is a rapid decrease in the velocity represented by a downward spike or negative acceleration. At 30 seconds, the velocity increases rapidly from zero to a constant value, and this is represented by an upward spike or positive acceleration. At 50 seconds, there is another negative acceleration as the velocity changes from a positive value to a negative value. If you could put yourself

inside the toy car, you would definitely feel these accelerations. (Everyday phenomenon box 2.2 provides another example of how a graph is useful for analyzing motion.)

### Can we find the distance traveled from the velocity graph?

What other information can be gleaned from the velocity-versus-time graph of figure 2.15? Think for a moment about how you would find the distance traveled if you knew the velocity. For a constant velocity, you can get the distance simply by multiplying the velocity by the time,  $d = vt$ . In the first 20 seconds of the motion, for example, the velocity is 0.8 cm/s and the distance traveled is 0.8 cm/s times 20 seconds, which is 16 cm. This is just the reverse of what we used in determining the velocity in the first place. We found the velocity by dividing the distance traveled by the time.

How would this distance be represented on the velocity graph? If you recall formulas for computing areas, you may recognize that the distance  $d$  is the area of the shaded rectangle on figure 2.15. The area of a rectangle is found by multiplying the height times the width, just what we have done here. The velocity, 0.8 cm/s, is the height, and the time, 20 seconds, is the width of this rectangle on the graph.

It turns out that we can find the distance this way even when the areas involved on the graph are not rectangles, although the process is more difficult when the curves are more complicated. The general rule is that the distance traveled is equal to the area under the velocity-versus-time curve. When the velocity is negative (below the time axis on the graph), the object is traveling backward and its distance from the starting point is decreasing.

Even without computing the area precisely, it is possible to get a rough idea of the distance traveled by studying the velocity graph. A large area represents a large distance. Quick visual comparisons give a good picture of what is happening without the need for lengthy calculations. This is the beauty of a graph.

A good graph can present a picture of motion that is rich in insight. Not only does distance traveled plotted against time tell us where the object is at any time, but also its slope indicates how fast it was moving. The graph of velocity plotted against time also contains information on acceleration and on the distance traveled. Producing and studying such graphs can give us a more general picture of the motion and the relationships between distance, velocity, and acceleration.

## Everyday Phenomenon

## Box 2.2

## The 100-m Dash

**The Situation.** A world-class sprinter can run 100 m in a little under 10 s. The race begins with the runners in a crouched position in the starting blocks, waiting for the sound of the starter's pistol. The race ends with the runners lunging across the finish line, where their times are recorded by stopwatches or automatic timers.



Runners in the starting blocks, waiting for the starter's pistol to fire. *Stockbyte/Getty Images*

What happens between the start and finish of the race? How do the velocity and acceleration of the runners vary during the race? Can we make reasonable assumptions about what the velocity-versus-time graph looks like for a typical runner? Can we estimate the maximum velocity of a good sprinter? Most importantly for improving performance, what factors affect the success of a runner in the dash?

**The Analysis.** Let's assume that the runner covers the 100-m distance in a time of exactly 10 s. We can compute the average speed of the runner from the definition  $s = d/t$ :

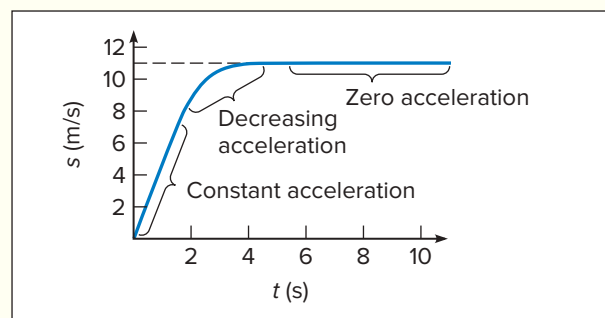
$$s = \frac{100 \text{ m}}{10 \text{ s}} = 10 \text{ m/s}$$

Clearly, this is not the runner's instantaneous speed throughout the course of the race, because the runner's speed at the beginning of the race is zero and it takes some time to accelerate to the maximum speed.

The objective in the race is to reach a maximum speed as quickly as possible and to sustain that speed for the rest of the race. Success is determined by two things: how quickly the runner can accelerate to this maximum speed and the value of this maximum speed. A smaller runner often has better acceleration but a smaller maximum speed, while a larger runner sometimes takes longer to reach top speed but has a larger maximum speed.

The typical runner takes at least 10 to 20 m to reach top speed. If the average speed is 10 m/s, the runner's maximum

speed must be somewhat larger than this value, because we know that the instantaneous speed will be less than 10 m/s while the runner is accelerating. These ideas are easiest to visualize by sketching a graph of speed plotted against time, as shown. Because the runner travels in a straight line, the magnitude of the instantaneous velocity is equal to the instantaneous speed. The runner reaches top speed at approximately 2 to 3 s into the race.



A graph of speed versus time for a hypothetical runner in the 100-m dash.

The average speed (or velocity) during the time that the runner is accelerating is approximately half of its maximum value if the runner's acceleration is more or less constant during the first 2 s. If we assume that the runner's average speed during this time is about 5.5 m/s (half of 11 m/s), then the speed through the remainder of the race would have to be about 11.1 m/s to give an average speed of 10 m/s for the entire race. This can be seen by computing the distance from these values:

$$\begin{aligned} d &= (5.5 \text{ m/s})(2 \text{ s}) + (11.1 \text{ m/s})(8 \text{ s}) \\ &= 11 \text{ m} + 89 \text{ m} = 100 \text{ m} \end{aligned}$$

What we have done here is make some reasonable guesses for these values that will make the average speed come out to 10 m/s. We then checked these guesses by computing the total distance. This suggests that the maximum speed of a good sprinter must be about 11 m/s (25 MPH). For the sake of comparison, a distance runner who can run a 4-minute mile has an average speed of about 15 MPH, or 6.7 m/s.

The runner's strategy should be to get a good jump out of the blocks, keeping the body low initially and leaning forward to minimize air resistance and maximize leg drive. To maintain top speed during the remainder of the race, the runner needs good endurance. A runner who fades near the end needs more conditioning drills. For a given runner with a fixed maximum speed, the average speed depends on how quickly the runner can reach top speed. This ability to accelerate rapidly depends on leg strength (which can be improved by working with weights and other training exercises) and natural quickness.

## 2.5 Uniform Acceleration

If you drop a rock, it falls toward the ground with a constant acceleration, as we will see in chapter 3. An unchanging, or **uniform, acceleration** is the simplest form of accelerated motion. It occurs whenever there is a constant force acting on an object, which is the case for a falling rock, as well as for many other situations.

How do we describe the resulting motion? The importance of this question was first recognized by Galileo, who studied the motion of balls rolling down inclined planes as well as objects in free fall. In his famous work *Dialogues Concerning Two New Sciences*, published in 1638 near the end of his life, Galileo developed the graphs and formulas that are introduced in this section and that have been studied by students of physics ever since. His work provided the foundation for much of Newton's thinking a few decades later.

### How does velocity vary in uniform acceleration?

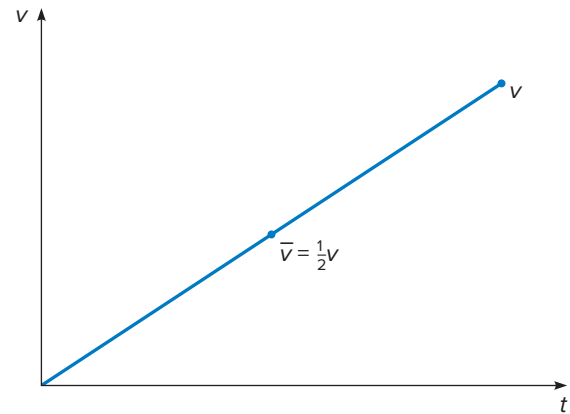
Suppose a car is moving along a straight road and accelerating at a constant rate. We have plotted the acceleration against time for this situation in figure 2.17. The graph is very simple, but it illustrates what is meant by uniform acceleration. A uniform acceleration is one that does not change as the motion proceeds. It has the same value at any time, which produces a horizontal-line graph.

The graph of velocity plotted against time for the same situation tells a more interesting story. From our discussion in section 2.4, we know that the slope of a velocity-versus-time graph is equal to the acceleration. For a uniform positive acceleration, the velocity graph should have a constant upward slope; the velocity increases at a steady rate. A constant slope produces a straight line, which slopes upward if the acceleration is positive, as shown in figure 2.18. In plotting this graph, we assume that the initial velocity is zero.

This graph can also be represented by a formula. The velocity at any time  $t$  is equal to the original velocity *plus* the velocity that has been gained because the car is accelerating. The change in velocity  $\Delta v$  is equal to the acceleration times



**Figure 2.17** The acceleration graph for uniform acceleration is a horizontal line. The acceleration does not change with time.



**Figure 2.18** Velocity plotted against time for uniform acceleration, starting from rest. For this special case, the average velocity is equal to one-half the final velocity.

the time,  $\Delta v = at$  because acceleration is defined as  $\Delta v/t$ . These ideas result in the relationship

$$v = v_0 + at$$

The first term on the right,  $v_0$ , is the original velocity (assumed to be zero in figure 2.18), and the second term,  $at$ , represents the change in velocity due to the acceleration. Adding these two terms together yields the velocity at any later time  $t$ .

A numerical example applying these ideas to an accelerating car is found in part a of example box 2.4. The car could not keep on accelerating indefinitely at a constant rate, because the velocity would soon reach incredible values. Not only is this dangerous, but physical limits imposed by air resistance and other factors prevent this from happening.

### Example Box 2.4

#### Sample Exercise: Uniform Acceleration

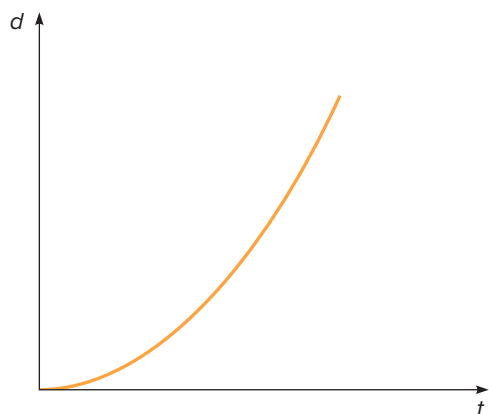
A car traveling due east with an initial velocity of 10 m/s accelerates for 6 seconds at a constant rate of 4 m/s<sup>2</sup>.

- What is its velocity at the end of this time?
- How far does it travel during this time?

$$\begin{array}{ll} \text{a. } v_0 = 10 \text{ m/s} & v = v_0 + at \\ a = 4 \text{ m/s}^2 & = 10 \text{ m/s} + (4 \text{ m/s}^2)(6 \text{ s}) \\ t = 6 \text{ s} & = 10 \text{ m/s} + 24 \text{ m/s} \\ v = ? & = \mathbf{34 \text{ m/s}} \end{array}$$

$$v = 34 \text{ m/s due east}$$

$$\begin{array}{l} \text{b. } d = v_0 t + \frac{1}{2} at^2 \\ = (10 \text{ m/s})(6 \text{ s}) + \frac{1}{2} (4 \text{ m/s}^2)(6 \text{ s})^2 \\ = 60 \text{ m} + (2 \text{ m/s}^2)(36 \text{ s}^2) \\ = 60 \text{ m} + 72 \text{ m} = \mathbf{132 \text{ m}} \end{array}$$



**Figure 2.19** As the car accelerates uniformly, the distance covered grows more and more rapidly with time, because the velocity is increasing.

What happens if the acceleration is negative? Velocity would decrease rather than increase, and the slope of the velocity graph would slope downward rather than upward. Because the acceleration is then negative, the second term in the formula for  $v$  would subtract from the first term, causing the velocity to decrease from its initial value. The velocity then decreases at a steady rate.

### How does distance traveled vary with time?

If the velocity is increasing at a steady rate, what effect does this have on the distance traveled? As the car moves faster and faster, the distance covered grows more and more rapidly. Galileo showed how to find the distance for this situation.

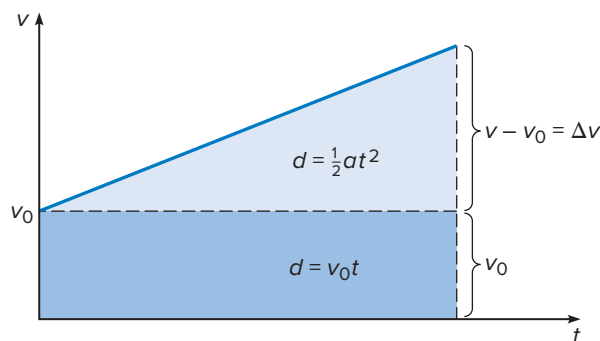
We find distance by multiplying velocity by time, but in this case we must use an average velocity, because the velocity is changing. By appealing to the graph in figure 2.18, we can see that the average velocity should be just half the final velocity,  $v$ . If the initial velocity is zero, the final velocity is  $at$ , so multiplying the average velocity by the time yields

$$d = \frac{1}{2}at^2$$

The time  $t$  enters twice, once in finding the average velocity and then again when we multiply the velocity by time to find the distance.\*

The graph in figure 2.19 illustrates this relationship; the distance curve slopes upward at an ever-increasing rate as the velocity increases. This formula and graph are only valid if the object starts from rest, as shown in figure 2.18. Because distance traveled is equal to the area under the velocity-versus-time curve (as discussed in section 2.4), this expression for distance can also be thought of as the area under the triangle in figure 2.18. The area of a triangle is equal to one-half its base times its height, which produces the same result.

\*Expressing this argument in symbolic form, it becomes the average velocity  $\bar{v} = \frac{1}{2}v = \frac{1}{2}at$  and  $d = \bar{v}t = \left(\frac{1}{2}at\right)t = \frac{1}{2}at^2$ .



**Figure 2.20** The velocity-versus-time graph redrawn for an initial velocity different from zero. The area under the curve is divided into two portions, a rectangle and a triangle.

If the car is already moving before it begins to accelerate, the velocity graph can be redrawn as in figure 2.20. The total area under the velocity curve can then be split into two pieces, a triangle and a rectangle, as shown. The total distance traveled is the sum of these two areas,

$$d = v_0t + \frac{1}{2}at^2$$

The first term in this formula represents the distance the object would travel if it moved with constant velocity  $v_0$ , and the second term is the additional distance traveled because the object is accelerating (the area of the triangle in figure 2.20). If the acceleration is negative, meaning that the object is slowing down, this second term will subtract from the first.

This more general expression for distance may seem complex, but the trick to understanding it is to break it down into its parts, as just suggested. We are merely adding two terms representing different contributions to the total distance. Each one can be computed in a straightforward manner, and it is not difficult to add them together. The two portions of the graph in figure 2.20 represent these two contributions.

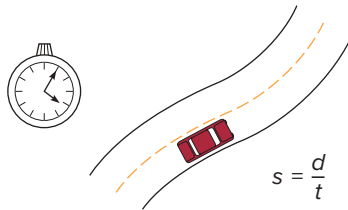
The sample exercise in example box 2.4 provides a numerical example of these ideas. The car in this example accelerates uniformly from an initial velocity of 10 m/s due east to a final velocity of 34 m/s due east and covers a distance of 132 meters while this acceleration is taking place. Had it not been accelerating, it would have gone only 60 meters in the same time. The additional 72 meters come because the car is accelerating.

Acceleration involves change, and uniform acceleration involves a steady rate of change. It therefore represents the simplest kind of accelerated motion that we can imagine. Uniform acceleration is essential to an understanding of free fall, discussed in chapter 3, as well as to many other phenomena. Such motion can be represented by either the graphs or the formulas introduced in this section. Looking at both and seeing how they are related will reinforce these ideas.

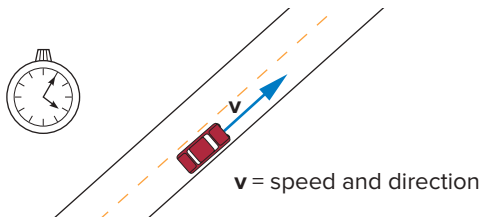
## Summary

The main purpose of this chapter is to introduce concepts that are crucial to a precise description of motion. To understand acceleration, you must first grasp the concept of velocity, which in turn builds on the idea of speed. The distinctions between speed and velocity, and between velocity and acceleration, are particularly important.

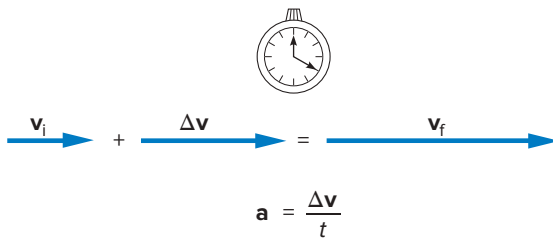
**1 Average and instantaneous speed.** Average speed is defined as the distance traveled divided by the time. It is the average rate at which distance is covered. Instantaneous speed is the rate at which distance is being covered at a given instant in time and requires that we use very short time intervals for computation.



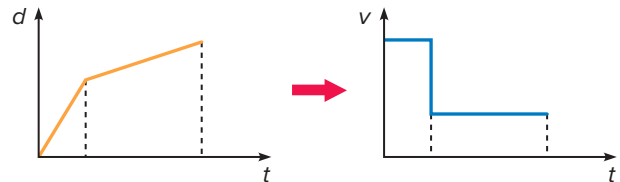
**2 Velocity.** The instantaneous velocity of an object is a vector quantity that includes both direction and size. The size of the velocity vector is equal to the instantaneous speed, and the direction is that of the object's motion.



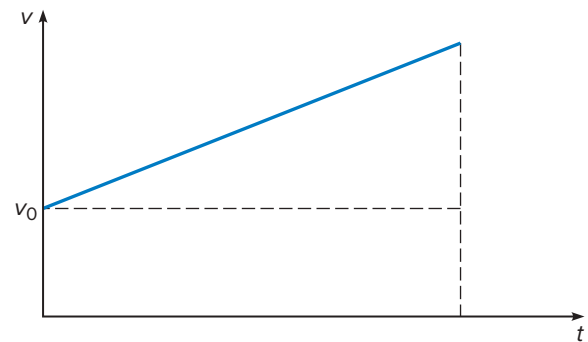
**3 Acceleration.** Acceleration is defined as the time rate of change of velocity and is found by dividing the *change* in velocity by the time. Acceleration is also a vector quantity. It can be computed as either an average or an instantaneous value. A change in the direction of the velocity can be as important as a change in magnitude. Both involve acceleration.



**4 Graphing motion.** Graphs of distance, speed, velocity, and acceleration plotted against time can illustrate relationships between these quantities. Instantaneous velocity is equal to the slope of the distance-time graph. Instantaneous acceleration is equal to the slope of the velocity-time graph. The distance traveled is equal to the area under the velocity-time graph.



**5 Uniform acceleration.** When an object accelerates at a constant rate, producing a constant-slope graph of velocity versus time, we say that it is uniformly accelerated. Graphs help us to understand the two formulas, describing how velocity and distance traveled vary with time for this important special case.



$$v = v_0 + at$$

$$d = v_0t + \frac{1}{2}at^2$$



The concepts of velocity and acceleration discussed in this chapter are often difficult to understand, particularly because we use the same terms in everyday life but often with different meanings. There are mastery quizzes and other helpful resources in Connect that will help you clarify your understanding of these ideas. We encourage you to try them.

## Key Terms

Speed, 19  
Average speed, 19  
Rate, 20  
Instantaneous speed, 21  
Velocity, 23

Magnitude, 23  
Vector, 23  
Vector quantity, 24  
Instantaneous velocity, 24  
Acceleration, 24

Average acceleration, 25  
Instantaneous acceleration, 25  
Slope, 28  
Uniform acceleration, 31

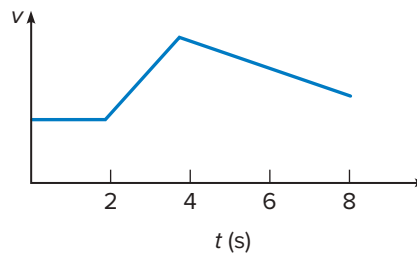
## Conceptual Questions

\* = more open-ended questions, requiring lengthier responses, suitable for group discussion

Q = sample responses are available in appendix D

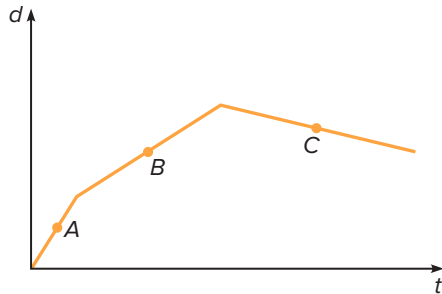
Q = sample responses are available in Connect

- Q1. Suppose that critters are discovered on Mars that measure distance in *boogles* and time in *bops*.
- What would the units of speed be in this system? Explain.
  - What would the units of velocity be? Explain.
  - What would the units of acceleration be? Explain.
- Q2. Suppose we chose inches as our basic unit of distance and days as our basic unit of time.
- What would the units of velocity and acceleration be in this system? Explain.
  - Would this be a good choice of units for measuring the acceleration of an automobile? Explain.
- Q3. What units would have an appropriate size for measuring the rate at which fingernails grow? Explain.
- Q4. A tortoise and a hare cover the same distance in a race. The hare goes very fast for brief intervals but stops frequently, whereas the tortoise plods along steadily and finishes the race ahead of the hare.
- Which of the two racers has the greater average speed over the duration of the race? Explain.
  - Which of the two racers is likely to reach the greatest instantaneous speed during the race? Explain.
- Q5. A driver states that she was doing 80 when stopped by the police. Is that a clear statement? Would this be interpreted differently in England than in the United States? Explain.
- Q6. Does the speedometer on a car measure average speed or instantaneous speed? Explain.
- Q7. Is the average speed over several minutes more likely to be close to the instantaneous speed at any time for a car traveling in freely flowing, low-density traffic or for one traveling in high-density traffic? Explain.
- \*Q8. The highway patrol sometimes uses radar guns to identify possible speeders and at other times uses associates in airplanes, who note the time taken for a car to pass between two marks some distance apart on the highway. What does each of these methods measure, average speed or instantaneous speed? Can you think of situations in which either one of these methods might unfairly penalize a driver? Explain.
- Q9. Is the term *vehicle density* (as used in everyday phenomenon box 2.1) related to the weight of an individual vehicle, or does it refer to a property of several vehicles? Explain.
- Q10. Under what traffic conditions is the average speed of several vehicles equal to the average speed of individual vehicles within the group? Explain. (See everyday phenomenon box 2.1.)
- Q11. At the front end of a traffic jam, is the vehicle density higher or lower than at the back end of the traffic jam? Explain. (See everyday phenomenon box 2.1.)
- Q12. A hockey puck is sliding on frictionless ice. It slams against a wall and bounces back toward the player with the same speed it had before hitting the wall. Does the velocity of the hockey puck change in this process? Explain.
- Q13. A ball attached to a string is whirled in a horizontal circle such that it moves with constant speed.
- Does the velocity of the ball change in this process? Explain.
  - Is the acceleration of the ball equal to zero? Explain.
- \*Q14. A ball tied to a string fastened at the other end to a rigid support forms a pendulum. If we pull the ball to one side and release it, the ball moves back and forth along an arc determined by the string length.
- Is the velocity constant in this process? Explain.
  - Is the speed likely to be constant in this process? What happens to the speed when the ball reverses direction?
- Q15. A dropped ball gains speed as it falls. Can the velocity of the ball be constant in this process? Explain.
- Q16. A driver of a car steps on the brakes, causing the velocity of the car to decrease. According to the definition of acceleration provided in this chapter, does the car accelerate in this process? Explain.
- Q17. At a given instant in time, two cars are traveling at different velocities, one twice as large as the other. Based on this information, is it possible to say which of these two cars has the larger acceleration at this instant in time? Explain.
- Q18. A car just starting up from a stop sign has zero velocity at the instant it starts. Must the acceleration of the car also be zero at this instant? Explain.
- Q19. A car traveling with constant speed rounds a curve in the highway. Is the acceleration of the car equal to zero in this situation? Explain.
- Q20. A racing sports car traveling with a constant velocity of 100 MPH due west startles a turtle by the side of the road and the turtle begins to move out of the way. Which of these two objects is likely to have the larger acceleration at that instant? Explain.
- Q21. In the graph shown here, velocity is plotted as a function of time for an object traveling in a straight line.
- Is the velocity constant for any time interval shown? Explain.
  - During which time interval shown does the object have the greatest acceleration? Explain.



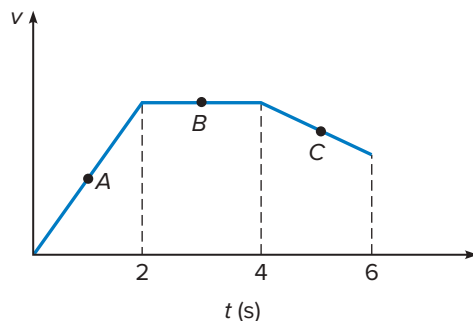
Q21 Diagram

- Q22. A car moves along a straight line, so that its position (distance from some starting point) varies with time as described by the graph shown here.
- Does the car ever go backward? Explain.
  - Is the instantaneous velocity at point A greater or less than that at point B? Explain.



Q22 Diagram

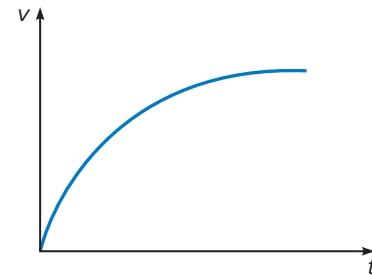
- Q23. For the car whose distance is plotted against time in question 22, is the velocity constant during any time interval shown in the graph? Explain.
- Q24. A car moves along a straight section of road, so that its velocity varies with time as shown in the graph.
- Does the car ever go backward? Explain.
  - At which of the labeled points on the graph, A, B, or C, is the magnitude of the acceleration the greatest? Explain.



Q24 Diagram

- Q25. For the car whose velocity is plotted in question 24, in which of the equal time segments 0–2 seconds, 2–4 seconds, or 4–6 seconds is the distance traveled by the car the greatest? Explain.
- Q26. Look again at the velocity-versus-time graph for the toy car shown in figure 2.15.
- Is the instantaneous speed greater at any time during this motion than the average speed for the entire trip? Explain.
  - Is the car accelerated when the direction of the car is reversed at  $t = 50$  s? Explain.
- Q27. Suppose the acceleration of a car increases with time. Could we use the relationship  $v = v_0 + at$  in this situation? Explain.

- Q28. When a car accelerates uniformly from rest, which of these quantities increases with time: acceleration, velocity, and/or distance traveled? Explain.
- Q29. The velocity-versus-time graph of an object curves as shown in the diagram. Is the acceleration of the object constant? Explain.



Q29 Diagram

- Q30. For a uniformly accelerated car, is the average acceleration equal to the instantaneous acceleration? Explain.
- Q31. A car traveling in the forward direction experiences a *negative* uniform acceleration for 10 seconds. Is the distance covered during the first 5 seconds equal to, greater than, or less than the distance covered during the second 5 seconds? Explain.
- Q32. A car starts from rest, accelerates uniformly for 5 seconds, travels at constant velocity for 5 seconds, and finally decelerates uniformly for 5 seconds. Sketch graphs of velocity versus time and acceleration versus time for this situation.
- Q33. Suppose that two runners run a 100-meter dash, but the first runner reaches maximum speed more quickly than the second runner. Both runners maintain constant speed once they have reached their maximum speed and cross the finish line at the same time. Which runner has the larger maximum speed? Explain. (See everyday phenomenon box 2.2.)
- Q34. Sketch a graph showing velocity-versus-time curves for the two runners described in question 33. Sketch both curves on the same graph, so that the differences are apparent. (See everyday phenomenon box 2.2.)
- \*Q35. A physics instructor walks with increasing speed across the front of the room, then suddenly reverses direction and walks backward with constant speed. Sketch graphs of velocity and acceleration consistent with this description.
- Q36. Draw a velocity-versus-time graph for the situation described in example box 2.4. Then, determine the distance traveled from the area under the curve.
- Q37. Return to example box 2.4, but this time assume the acceleration is a negative  $1 \text{ m/s}^2$ ; in other words, the car is slowing down. Using the same equations (and same initial velocity of  $+10 \text{ m/s}$ ), determine the final velocity after 6 seconds, and the distance traveled after 6 seconds. Then, graph the velocity-versus-time graph and determine the distance traveled from the area under the curve.



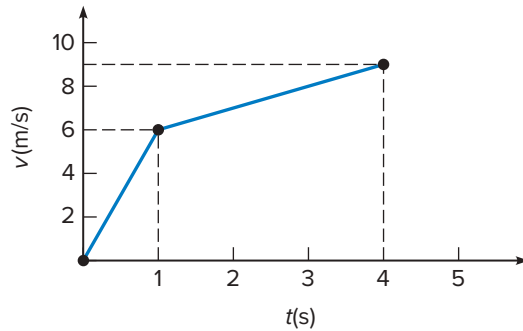
## Exercises

- E1. A traveler covers a distance of 413 miles in a time of 7 hours. What is the average speed for this trip?
- E2. A walker covers a distance of 2.4 km in a time of 30 minutes. What is the average speed of the walker for this distance in km/h?
- E3. Grass clippings are found to have an average length of 5.2 cm when a lawn is mowed 2 weeks (14 days) after the previous mowing. What is the average speed of growth of this grass in cm/day?
- E4. A driver drives for 2.5 hours at an average speed of 68 MPH. What distance does she travel in this time?
- E5. A woman walks a distance of 504 m, with an average speed of 1.4 m/s. What time was required to walk this distance?
- E6. A person in a hurry averages 70 MPH on a trip covering a distance of 500 miles. What time was required to travel that distance?
- E7. A hiker walks with an average speed of 1.3 m/s. What distance in kilometers has the hiker traveled after 1.5 hours at this pace?
- E8. A car travels with an average speed of 28 m/s.  
a. What is this speed in km/s?  
b. What is this speed in km/h?
- E9. A car travels with an average speed of 65 MPH. What is this speed in km/h? (See example box 2.1.)
- E10. Starting from rest and moving in a straight line, a cheetah can achieve a velocity of 31 m/s (approximately 69 mph!) in 4 seconds. What is the average acceleration of the cheetah?
- E11. The velocity of a car decreases from 28 m/s to 20 m/s in a time of 4 seconds. What is the average acceleration of the car in this process? (See example box 2.3.)
- E12. Starting from rest, a car accelerates at a rate of  $6.7 \text{ m/s}^2$  for a time of 4 seconds. What is its velocity at the end of this time? (See example box 2.4a.)
- E13. A car traveling with an initial velocity of 27 m/s slows down at a constant rate of  $5.4 \text{ m/s}^2$  for 3 seconds. What is its velocity at the end of this time?
- E14. A car traveling with an initial velocity of 16 m/s accelerates at a constant rate of  $2.8 \text{ m/s}^2$  for a time of 3 seconds. (See example box 2.4.)  
a. What is its velocity at the end of this time?  
b. What distance does the car travel during this process?
- E15. A runner traveling with an initial velocity of 1.1 m/s accelerates at a constant rate of  $0.8 \text{ m/s}^2$  for a time of 2 seconds.  
a. What is his velocity at the end of this time?  
b. What distance does the runner cover during this process?
- E16. A car moving with an initial velocity of 32 m/s slows down at a constant rate of  $-4 \text{ m/s}^2$ .  
a. What is its velocity after 5 seconds of deceleration?  
b. What distance does the car cover in this time?
- E17. A runner moving with an initial velocity of 4.0 m/s slows down at a constant rate of  $-1.6 \text{ m/s}^2$  over a period of 2 seconds.  
a. What is her velocity at the end of this time?  
b. What distance does she travel during this process?
- E18. If a world-class sprinter ran a distance of 100 meters starting at his top speed of 9 m/s and running with constant speed throughout, how long would it take him to cover the distance?
- E19. In 1950, the world record holder for the 400-meter dash was Jamaican George Rhoden. If his average speed during his record dash was 8.73 m/s, how long did it take him to run the race?
- E20. Starting from rest, a cheetah accelerates at a constant rate of  $7.75 \text{ m/s}^2$  for a time of 4 seconds.  
a. Compute the velocity of the cheetah at 1 s, 2 s, 3 s, and 4 s and plot these velocity values against time.  
b. Compute the distance traveled by the cheetah for these same times and plot the distance values against time.
- E21. A race car has a speed of 90 m/s. The driver hits the brakes, causing the car to slow down at a constant rate of  $11 \text{ m/s}^2$  for a period of 8 seconds.  
a. Compute the speed of the car at 2 s, 4 s, 6 s, and 8 s after the driver hits the brakes, and plot these values against time.  
b. Compute the distance traveled by the car for the same times, and plot the distance values against time.

## Synthesis Problems

- SP1. A railroad engine moves forward along a straight section of track for a distance of 70 m due west at a constant speed of 5 m/s. It then reverses its direction and travels 32 m due east at a constant speed of 4 m/s. The time required for this deceleration and reversal is very short due to the small speeds involved.  
a. What is the time required for the entire process?  
b. Sketch a graph of average speed versus time for this process. Show the deceleration and reacceleration upon reversal as occurring over a very short time interval.  
c. Using negative values of velocity to represent reversed motion, sketch a graph of velocity versus time for the engine (see fig. 2.15).  
d. Sketch a graph of acceleration versus time for the engine (see fig. 2.16).
- SP2. The velocity of a car increases with time, as shown in the graph.  
a. What is the average acceleration between 0 seconds and 1 second?

- What is the average acceleration between 1 second and 4 seconds?
- What is the average acceleration between 0 seconds and 4 seconds?
- Is the result in part c equal to the average of the two values in parts a and b? Compare and explain.



SP2 Diagram

- SP3. A car traveling due west on a straight road accelerates at a constant rate for 10 seconds, increasing its velocity from 0 to 30 m/s. It then travels at a constant speed for 10 seconds and decelerates at a steady rate for the next 5 seconds to a velocity of 20 m/s. It travels at this velocity for 5 seconds and then decelerates rapidly to a stop in a time of 4 seconds.

- Sketch a graph of the car's velocity versus time for the entire motion. Label the axes of your graph with the appropriate velocities and times.
- Sketch a graph of acceleration versus time for the car.
- Does the distance traveled by the car continually increase in the motion described? Explain.

- SP4. A car traveling in a straight line with an initial velocity of 10 m/s accelerates at a rate of  $3.0 \text{ m/s}^2$  to a velocity of 34 m/s.

- How much time does it take for the car to reach the velocity of 34 m/s?
- What is the distance covered by the car in this process?
- Compute values of the distance traveled at 1-second intervals and carefully draw a graph of distance plotted against time for this motion.

- SP5. Just as car A is starting up, it is passed by car B. Car B travels with a constant velocity of 7 m/s, while car A accelerates with a constant acceleration of  $4.2 \text{ m/s}^2$ , starting from rest.

- Compute the distance traveled by each car for times of 1 s, 2 s, 3 s, and 4 s.
- At what time, approximately, does car A overtake car B?
- How might you go about finding this time exactly? Explain.

## Home Experiments and Observations

- HE1. How fast do you normally walk? Using a meter stick or a string of known length, lay out a straight course of 40 or 50 meters. Then, use a watch with a second hand or a stopwatch to determine
- Your normal walking speed in m/s.
  - Your walking speed for a brisk walk.
  - Your jogging speed for this distance.
  - Your sprinting speed for this distance.

Record and compare the results for these different cases. Is your sprinting speed more than twice your speed for a brisk walk?

- HE2. The speed with which hair and fingernails grow provides some interesting measurement challenges. Using a millimeter rule, estimate the speed of growth for one or more of these: fingernails, toenails, facial hair if you shave regularly, or hair near your face (such as sideburns) that will provide an easy reference point. Measure the average size of clippings or of growth at regular time intervals.
- What is the average speed of growth? What units are most appropriate for describing this speed?
  - Does the speed appear to be constant with time? Does the speed appear to be the same for different nails (thumb versus fingers, fingernails versus toenails) or, in the case of hair, for different positions on your face?

Studio Photogram/Alamy Stock Photo

## Falling Objects and Projectile Motion

### Chapter Overview

Our main purpose in this chapter is to explore how objects move under the influence of the gravitational acceleration near the Earth's surface. Uniform acceleration, introduced in chapter 2, plays a prominent role. We begin by considering carefully the acceleration of a dropped object, and then we extend these ideas to thrown objects or objects projected at an angle to the ground.

### Chapter Outline

- 1 Acceleration due to gravity.** How does a dropped object move under the influence of the Earth's gravitational pull? How is its acceleration measured, and in what sense is it constant?
- 2 Tracking a falling object.** How do velocity and distance traveled vary with time for a falling object? How can we quickly estimate these values knowing the gravitational acceleration?
- 3 Beyond free fall: Throwing a ball upward.** What changes when a ball is thrown upward rather than dropped? Why does the ball appear to hover near the top of its flight?
- 4 Projectile motion.** What determines the motion of an object that is fired horizontally? How do the velocity and position of the object change with time in this case?
- 5 Hitting a target.** What factors determine the trajectory of a rifle bullet or football that has been launched at some angle to the horizontal to hit a target?

**H**ave you ever watched a leaf or a ball fall to the ground? At times during your first few years of life, you probably amused yourself by dropping an object repeatedly and watching it fall. As we grow older, that experience becomes so common that we usually do not stop to think about it or to ask why objects fall as they do, yet this question has intrigued scientists and philosophers for centuries.

To understand nature, we must first carefully observe it. If we control the conditions under which we make our observations, we are doing an experiment. The observations of falling objects that you performed as a young child were a simple form of experiment, and we would like to rekindle that interest in experimentation here. Progress in science has depended on carefully controlled experiments, and your own progress in understanding nature will depend on your active testing of ideas through experiments. You may be amazed at what you discover.

Look around for some small, compact objects. A short pencil, a rubber eraser, a paper clip, or a small ball will all do nicely. Holding two objects at arm's length, release them simultaneously and watch them fall to the floor (fig. 3.1). Be careful to release them from the same height above the floor without giving either one an upward or downward push.

How would you describe the motion of these falling objects? Is their motion accelerated? Do they reach the floor at the same time? Does the motion depend on the shape and composition of the object? To explore this last question, you might take a small piece of paper and drop it at the same time as an eraser or a ball. First, drop the paper unfolded.



**Figure 3.1** An experimenter dropping objects of different mass. Do they reach the ground at the same time?

*Jill Braaten/McGraw-Hill Education*

Then, try folding it or crumpling it into a ball. What difference does this make?

From these simple experiments, we can draw some general conclusions about the motion of falling objects. We can also try throwing or projecting objects at different angles to study the motion of a projectile. We will find that a constant downward gravitational acceleration is involved in all of these cases. This acceleration affects virtually everything we do when we move or play on the surface of the Earth.

### 3.1 Acceleration Due to Gravity

If you dropped a few objects as suggested in this chapter's introduction, you already know the answer to one of the questions posed there. Are the falling objects accelerated? Think for a moment about whether the velocity is changing. Before you release an object, its velocity is zero, but an instant after the object is released, the velocity has some value different from zero. There has been a change in velocity. If the velocity is changing, there is an acceleration.

Things happen so rapidly that it is difficult, just from watching the fall, to say much about the acceleration. It does appear to be large, because the velocity increases rapidly. Does the object reach a large velocity instantly, or does the acceleration occur more uniformly? To answer this question, we must slow down the motion somehow, so that our eyes and brains can keep up with what is happening.

#### How can we measure the gravitational acceleration?

There are several ways to view the action in slow motion. One was pioneered by Italian scientist Galileo Galilei (1564–1642), who was the first to accurately describe the *acceleration due to gravity*. Galileo's method was to roll or

slide objects down a slightly inclined plane. This allows only a small portion of the gravitational acceleration to come into play, just that part in the direction of motion along the plane. Thus, a smaller acceleration results. Other methods (not available to Galileo) use time-lapse photography, ultrasonic motion detectors, or video recording to locate the position of the falling object at different times.

If you happen to have a grooved ruler and a small ball or marble handy, you can make an inclined plane. Lift one end of the ruler slightly by placing a pencil under one end, and let the ball or marble roll down the ruler under the influence of gravity (fig. 3.2). Can you see it gradually pick up speed as it rolls? Is it clearly moving faster at the bottom of the incline than it was halfway down?

Galileo was handicapped by a lack of accurate timing devices. He often had to use his own pulse as a timer. Despite this limitation, he was able to establish that the acceleration was uniform, or constant, with time and to estimate its value using inclined planes. We are more fortunate. We have devices that allow us to study the motion of a falling object more directly. One such device is a stroboscope, a rapidly blinking light whose flashes occur at regular intervals in time. Figure 3.3 is a photograph taken using a stroboscope to illuminate an object as it falls. The position of the object is pinpointed every time the light flashes.

increasing in the downward direction. (For this example, it is convenient to choose downward as positive.)

Computing values of the average velocity for each time interval will make this even clearer. The computation can be done if we know the time interval between flashes and can measure the position of the ball from the photograph, knowing the distance between the grid marks. Table 3.1 displays data obtained in this manner. It shows the position of a ball at intervals of  $1/20$  of a second (0.05 second).

To see that the velocity is indeed increasing, we compute the average velocity for each successive time interval. For example, between the second and third flashes, the ball traveled a distance of 3.6 centimeters, which is found by subtracting 1.2 centimeters from 4.8 centimeters. Dividing this distance by the time interval of 0.05 second yields the average size of the velocity:

$$v = \frac{3.6 \text{ cm}}{0.05 \text{ s}} = 72 \text{ cm/s}$$

You could verify the other values shown in the third column of table 3.1 by doing similar computations.

It is clear in table 3.1 that the velocity values steadily increase. To see that velocity is increasing at a constant rate, we can plot velocity against time (fig. 3.4). Notice that each velocity data point is plotted at the midpoint between the two times (or flashes) from which it was computed. This is because these values represent the average velocity for the short time intervals between flashes. For constant acceleration, the

**Table 3.1** Distance and Average Velocity Values for a Falling Ball

Time	Distance	Average Velocity
0	0	
0.05 s	1.2 cm	24 cm/s
0.10 s	4.8 cm	72 cm/s
0.15 s	11.0 cm	124 cm/s
0.20 s	19.7 cm	174 cm/s
0.25 s	30.6 cm	218 cm/s
0.30 s	44.0 cm	268 cm/s
0.35 s	60.0 cm	320 cm/s
0.40 s	78.4 cm	368 cm/s
0.45 s	99.2 cm	416 cm/s
0.50 s	122.4 cm	464 cm/s

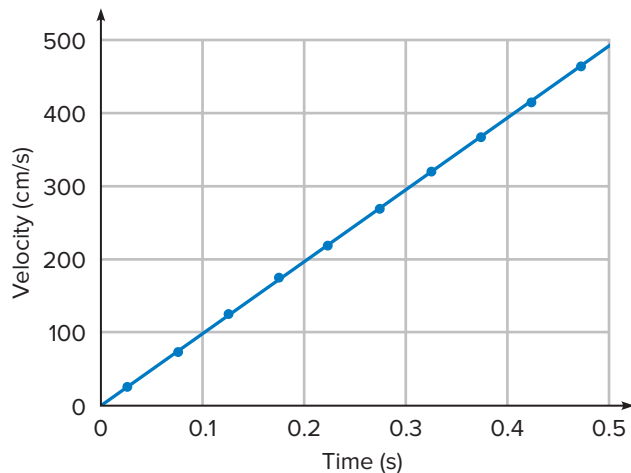


**Figure 3.2** A marble rolling down a ruler serving as an inclined plane. Does the velocity of the marble increase as it rolls down the incline?  
Jill Bratton/McGraw-Hill Education

If you look closely at figure 3.3, you will notice that the distance covered in successive time intervals increases regularly. The time intervals between successive positions of the ball are all equal. (If the stroboscope light flashes every  $1/20$  of a second, you are seeing the position of the ball in equal time intervals.) Since the distance covered by the ball increases, the velocity is increasing, the velocity must be increasing. Figure 3.3 shows a ball whose velocity is steadily



**Figure 3.3** A falling ball is illuminated by a rapidly blinking stroboscope. The stroboscope blinks at regular time intervals.  
Richard Megna/Fundamental Photographs, NYC



**Figure 3.4** Velocity plotted against time for the falling ball. The velocity values are those shown in table 3.1.

average velocity for any time interval is equal to the instantaneous velocity at the midpoint of that interval.

Did you notice that the slope of the line is constant in figure 3.4? The velocity values all fall approximately on a constant-slope straight line. Because acceleration is the slope of the velocity-versus-time graph, the acceleration must also be constant. The velocity increases uniformly with time.

To find the value of the acceleration, we choose two velocity values that lie on the straight line and calculate how rapidly the velocity is changing. For example, the last velocity value, 464 cm/s, and the second value, 72 cm/s, are separated by a time interval corresponding to eight flashes, or 0.40 second. The increase in velocity  $\Delta v$  is found by subtracting 72 cm/s from 464 cm/s, obtaining 392 cm/s. To find the acceleration, we divide this change in velocity by the time interval ( $a = \Delta v/t$ ),

$$a = \frac{392 \text{ cm/s}}{0.4 \text{ s}} = 980 \text{ cm/s}^2 = 9.8 \text{ m/s}^2$$

This result gives us the **acceleration due to gravity** for objects falling near the Earth's surface. Its value actually varies slightly from point to point on the Earth's surface because of differences in altitude and other effects. This acceleration is used so often that it is given its own symbol,  $g$ , where

$$g = 9.8 \text{ m/s}^2$$

Called the *gravitational acceleration* or *acceleration due to gravity*, it is valid only near the Earth's surface and thus is not a fundamental constant.

### How did Galileo's ideas on falling objects differ from Aristotle's?

There is another sense in which the gravitational acceleration is constant, which takes us back to the experiments suggested in the chapter opener: When you drop objects of different sizes and weights, do they reach the floor at the

same time? Except for an unfolded piece of paper, it is likely that all of the objects that you test, regardless of their weight, reach the floor at the same time when released simultaneously. This finding suggests that the gravitational acceleration does not depend on the weight of the object.

Galileo used similar experiments to prove this point. His experiments contradicted Aristotle's view that heavier objects fall more rapidly. How could Aristotle's idea have been accepted for so long when simple experiments can disprove it? Experimentation was not part of the intellectual outlook of Aristotle and his followers; they valued pure thought and logic more highly. Galileo and other scientists of his time broke new ground by using experiments as an aid to thinking. A new tradition was emerging.

On the other hand, Aristotle's view agrees with our intuition that heavy objects do fall more rapidly than some lighter objects. If, for example, we drop a brick together with a feather or an unfolded piece of paper (fig. 3.5), the brick will reach the floor first. The paper or feather will not fall in a straight line but instead will flutter to the floor much as a leaf falls from a tree. What is happening here?

You will probably recognize that the effects of **air resistance** impede the fall of the feather or paper much more than the fall of the brick, a steel ball, or a paper clip. When we crumple the piece of paper into a ball and drop it simultaneously with a brick or other heavy object, the two objects reach the floor at approximately the same time. We live at the bottom of a sea of air, and the effects of air resistance can be substantial for objects like leaves, feathers, or pieces of paper. These effects produce a slower and less regular flight for light objects that have a large surface area.

If we drop a feather and a brick simultaneously in a vacuum or in the very thin atmosphere of the moon, they do reach the ground at the same time. Moonlike conditions are not part of our everyday experience, however, so we are used to seeing feathers fall more slowly than rocks or bricks. Galileo's insight was that the gravitational acceleration is the same for all objects, regardless of their weight, provided that



**Figure 3.5** When a brick and a feather are dropped at the same time, the brick reaches the floor first.

Jill Braaten/McGraw-Hill Education

the effects of air resistance are not significant. Aristotle did not separate the effect of air resistance from that of gravity in his observations.

The gravitational acceleration for objects near the Earth's surface is uniform and has the value of  $9.8 \text{ m/s}^2$ . It can be measured by using stroboscopes or similar techniques to record the position of a falling object at regular, very small time intervals. This acceleration is constant in time. Contrary to Aristotle's belief, it also has the same value for objects of different weight.

### 3.2 Tracking a Falling Object

Imagine yourself dropping a ball from a sixth-story window, as in figure 3.6. How long does it take for the ball to reach the ground below? How fast is it traveling when it gets there? Things happen quickly, so the answers to these questions are not obvious.

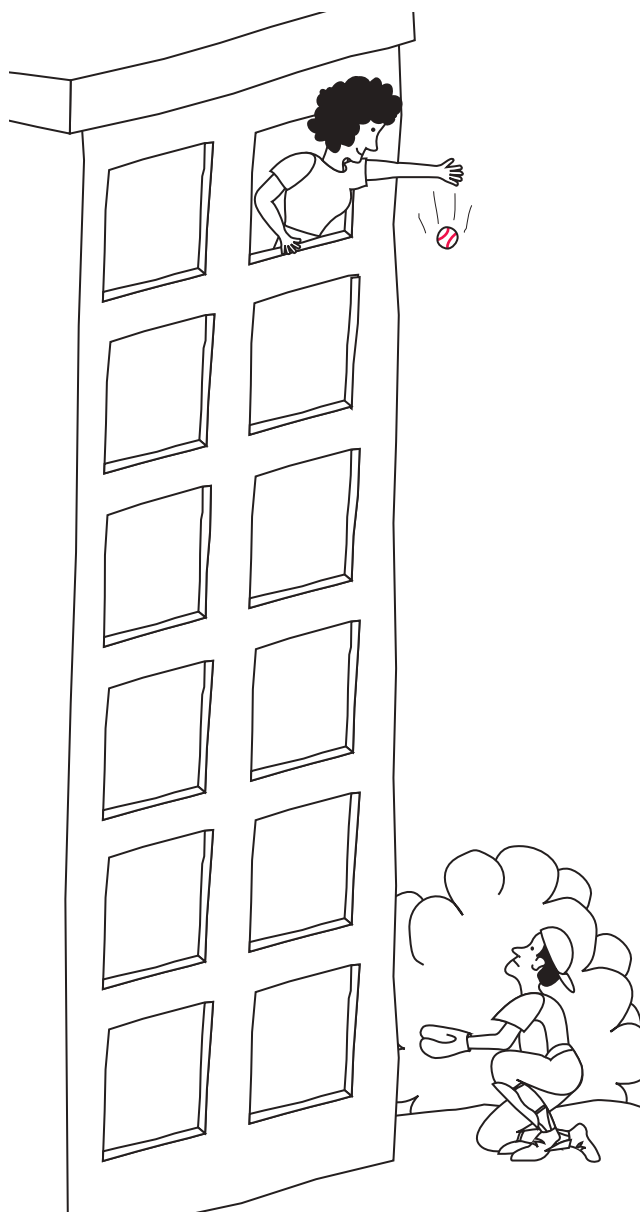
If we assume that air-resistance effects are small for the object we are tracking, we know that it accelerates toward the ground at the constant rate of  $9.8 \text{ m/s}^2$ . Let's make some quick estimates of how these values change with time without doing detailed computations.

#### How does the velocity vary with time?

In making estimates of velocity and distance for a falling object, we often take advantage of the fact that the gravitational-acceleration value of  $9.8 \text{ m/s}^2$  is almost  $10 \text{ m/s}^2$  and round it up. (*Here we are choosing the downward direction as positive.*) This makes the numerical values easier to calculate without sacrificing much in accuracy. Multiplying by 10 is quicker than multiplying by 9.8.

How fast is our dropped ball moving after 1 second? An acceleration of  $10 \text{ m/s}^2$  means that the velocity is increasing by  $10 \text{ m/s}$  each second. If its original velocity is zero, then after 1 second its velocity has increased to  $10 \text{ m/s}$ , in 2 seconds to  $20 \text{ m/s}$ , and in 3 seconds to  $30 \text{ m/s}$ . For each additional second, the ball gains  $10 \text{ m/s}$  in velocity.\*

To help you appreciate these values, look back at table 2.1, which shows unit comparisons for familiar speeds. A velocity of  $30 \text{ m/s}$  is roughly  $70 \text{ MPH}$ , so after 3 seconds the ball is moving quickly. After just 1 second, it is moving with a downward velocity of  $10 \text{ m/s}$ , which is over  $20 \text{ MPH}$ . The ball gains velocity at a faster rate than is possible for a high-powered automobile on a level surface.



**Figure 3.6** A ball is dropped from a sixth-story window. How long does it take to reach the ground?

#### How far does the ball fall in different times?

The high velocities are more meaningful if we examine how far the ball falls during these times. As the ball falls, it gains speed, so it travels farther in each successive time interval, as in the photograph in figure 3.3. Because of uniform acceleration, the distance increases at an ever-increasing rate.

During the first second of motion, the velocity of the ball increases from zero to  $10 \text{ m/s}$ . Its average velocity during that first second is  $5 \text{ m/s}$ , and it travels a distance of 5 meters in that second. This can also be found by using the relationship between distance, acceleration, and time in section 2.5.

\*In section 2.5, we noted that the velocity of an object moving with uniform acceleration is  $v = v_0 + at$ , where  $v_0$  is the original velocity and the second term is the change in velocity,  $\Delta v = at$ . When a ball is dropped,  $v_0 = 0$ , so  $v$  is just  $at$ , the change in velocity.

If the starting velocity is zero, we found that  $d = 1/2 at^2$ . After 1 second, the ball has fallen a distance

$$d = \frac{1}{2}(10 \text{ m/s}^2)(1 \text{ s})^2 = 5 \text{ m}$$

Because the height of a typical story of a multistory building is less than 4 meters, the ball falls more than one story in just a second.

During the next second of motion, the velocity increases from 10 m/s to 20 m/s, yielding an average velocity of 15 m/s for that interval. The ball travels 15 meters in that second, which, when added to the 5 meters covered in the first second, yields a total of 20 meters. After 2 seconds, the distance fallen is four times as large as the 5 meters traveled after 1 second.\* Because 20 meters is roughly five stories in height, the ball dropped from the sixth story will be near the ground after 2 seconds. Everyday phenomenon box 3.1 discusses how to approximate your reaction time using these ideas.

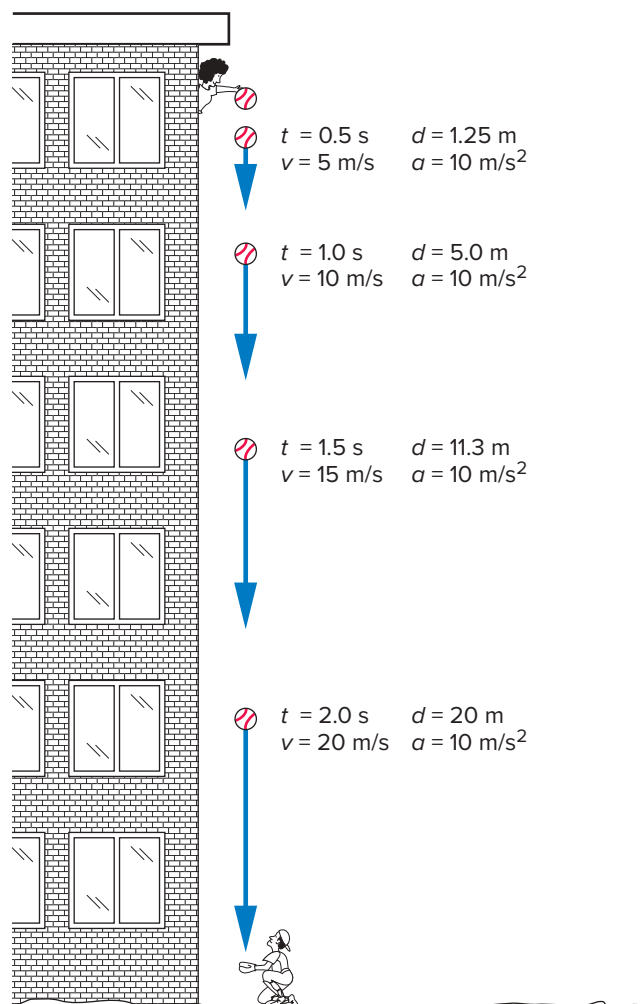
Figure 3.7 gives the velocity and distance fallen at half-second time intervals for a ball dropped from a six-story building. Notice that in just half a second, the ball falls 1.25 meters. An object dropped to the floor from an outstretched arm therefore hits the floor in roughly half a second. This makes it difficult to time with a stopwatch. (See example box 3.1.)

The change in velocity is proportional to the size of the time interval selected. In 1 second, the change in velocity is 10 m/s, so in half a second the change in velocity is 5 m/s. In each half-second, the ball gains approximately 5 m/s in velocity, as illustrated in figure 3.7. As the velocity gets larger, the arrows representing the velocity vectors grow. If we plotted these velocity values against time, we would get a simple, upward-sloping, straight-line graph, as in figure 3.4.

What does the graph of the distance values look like? The distance values increase in proportion to the square of the time, which means they increase more and more rapidly as time elapses. Instead of being a straight-line graph, the graph of the distance values curves upward, as in figure 3.8. The rate of change of distance with time is itself increasing with time.

### Throwing a ball downward

Suppose that instead of just dropping the ball, we throw it straight down, giving it a starting velocity  $v_0$  different from zero. How does this affect the results? Will the ball reach the ground more rapidly and with a larger velocity? You would probably guess correctly that the answer is yes.



**Figure 3.7** Approximate velocity and distance values for the dropped ball shown at half-second time intervals (using the approximate value  $g = 10 \text{ m/s}^2$ ).

### Example Box 3.1

#### Sample Question: Using a Pulse Rate to Time a Falling Object

**Question:** Suppose that Galileo's resting pulse rate was 60 beats per minute. Would his pulse be a useful timer for getting position-versus-time data for an object dropped from the height of 2 to 3 meters?

**Answer:** A pulse rate of 60 beats per minute corresponds to one beat per second. In the time of 1 second, a dropped object falls a distance of approximately 5 m. (It falls 1.22 m in just half a second, as seen in table 3.1.) Thus, this pulse rate (or most pulse rates) would not be an adequate timer for an object dropped from a height of a few meters. It could be slightly more effective for an object dropped from a tower several stories in height.

\*This is a result of the time being squared in the formula for distance. Putting 2 s in place of 1 s in the formula  $d = \frac{1}{2}at^2$  multiplies the result by a factor of  $4(2^2 = 4)$ , yielding a distance of 20 m.



## Everyday Phenomenon

## Box 3.1

## Reaction Time

**The Situation.** Have you ever wondered how fast your reaction time is? Many activities in our everyday lives are affected by how quickly we can react. The time it takes us to respond to a sudden slowdown in traffic when driving is one of the most important. Your score on video games is also a direct result of your reaction time to different stimuli.

How can we measure reaction time? A simple measurement can accomplish this without much difficulty. The Home Experiment HE2 at the end of this chapter describes a procedure in which a partner drops a meter stick placed between your open fingers. You catch it and measure how far it has fallen in the time that it takes for you to react to its motion and close your fingers. How does this permit you to calculate your reaction time, and what is the significance of the result?

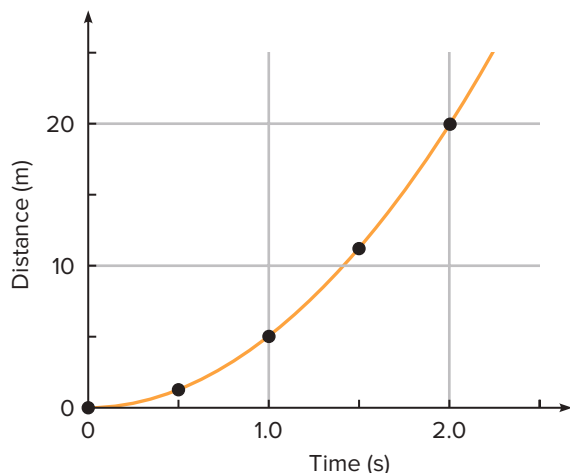
**The Analysis.** Home Experiment HE2 uses the equation relating the distance traveled by an accelerated object to the time of flight,  $d = 1/2at^2$ . Is the meter stick accelerating? Of course, it is, because its velocity is changing from an initial velocity of zero at its release to an increasing velocity as it falls. An object is said to be in **free fall** if the only force on the object is the gravitational force. The only other force acting on the meter stick is that of air resistance, which is discussed in chapter 4. However, air resistance is essentially negligible in the early part of the flight of an object such as a falling meter stick.

Thus, the acceleration of the meter stick is that due to gravity,  $a = g = 9.8 \text{ m/s}^2$ , as discussed in this section. In the Home Experiment, we solve the distance equation for the time, so if we know the distance that the meter stick has fallen until your



Jill Braaten

(continued)



**Figure 3.8** A plot of approximate distance versus time for the dropped ball.

In the case of the velocity values, the effect of the starting velocity is not difficult to see. The ball is still being accelerated by gravity, so that the change in velocity for each second of motion is still  $\Delta v = 10 \text{ m/s}$ , or for a half-second,  $5 \text{ m/s}$ . If the initial downward velocity is  $20 \text{ m/s}$ , after half a second the velocity is  $25 \text{ m/s}$ , and after 1 second it is  $30 \text{ m/s}$ . We simply add the change in velocity to the initial velocity, as indicated by the formula  $v = v_0 + at$ .

In the case of distance, however, the values increase more rapidly. The full expression for distance traveled by a uniformly accelerated object (introduced in section 2.5) is

$$d = v_0t + \frac{1}{2}at^2$$

The first term is the distance the ball would travel if it continued to move with just its original velocity. This distance

fingers close, we can calculate the time of flight. This time is your reaction time.

Some issues arise in determining an accurate reaction time. Those measuring the reaction time should not look at the person dropping the meter stick—they should keep their eyes on the stick itself. It is extremely difficult for your partner to avoid indicating in subtle, but recognizable, ways that he or she is about to release the meter stick. A few practice trials are in order to get a feel for the procedure. Doing the experiment several times and averaging the results will produce a much more accurate value than that of a single trial.

What processes are taking place when you react to a falling meter stick? Obviously, the sight of the meter stick dropping must be transmitted to the brain, and then the brain must signal the fingers to close. Details of these processes lie in the realm of biological physics and neurobiology. A “normal” reaction time for a young adult is between 0.2 and 0.25 second. Does your reaction time fall in this range?

How does your reaction time affect your stopping distance when driving a car? A general guideline when driving is to allow at least one car length (usually assumed to be 16 ft, or 4.9 m) between you and the car in front of you for every 10 MPH of your speed. This guideline takes into account not only your reaction time but also how long it takes to stop the car once you step on the brakes. How far will you travel while your brain is processing that you need to stop and then while a signal from the brain is reaching your foot?

The accompanying table gives the distance in meters that you would travel at different speeds before you even began to apply the brakes, assuming that you had a reaction time of 0.25 second. Thus, if you are traveling at 50 MPH, you will travel more than a car length before you touch the brakes.

Even at 40 MPH, you will travel almost one car length. Are you surprised?

MPH	km/hr	Meters Covered in 0.25 sec
10	16	1.1
20	32	2.2
30	48	3.4
40	64	4.5
50	81	5.6
60	97	6.7
70	113	7.8

These ideas demonstrate the danger of tailgating. If you are tailgating a car at 50 MPH and you see its brake lights go on, you will travel 5.6 meters before you can apply your brakes. Because the other car is already slowing down, this is likely to result in a rear-end collision, assuming that your brakes are no better than the other car’s.

Once you know how to compute your reaction time using this simple technique, you can explore how various conditions affect it. Does sleep deprivation affect your reaction time? If you consume a lot of caffeine, does your reaction time improve or get worse? Does your reaction time change during the course of the day? You can do simple scientific experiments to answer these questions. Perhaps you will discover the best conditions to improve your video game scores, or when it is safest to get behind the wheel of a car.

also increases with time. The second term is due to the acceleration and has the same values as shown in figures 3.7 and 3.8.

In the sample exercise in example box 3.2, we calculate velocity and distance traveled during the first 2 seconds of motion for a ball thrown downward. Notice that after 2 seconds the ball has traveled a distance of 60 meters, much farther than the 20 meters when the ball is simply dropped. After just 1 second, the ball has already traveled 25 meters, which means it would be near the ground if thrown from our sixth-story window.

Keep in mind, though, that we have ignored the effects of air resistance in arriving at these results. For a compact object falling just a few meters, the effects of air resistance are very small. These effects increase as the velocity increases, however, so that the farther the object falls, the

greater the effects of air resistance. In chapter 4, we will discuss the role of air resistance in more depth in the context of sky diving.

When an object is dropped, its velocity increases by approximately 10 m/s every second due to the gravitational acceleration. The distance traveled increases at an ever-increasing rate, because the velocity is increasing. In just a few seconds, the object is moving very rapidly and has fallen a large distance. In section 3.3, we will explore the effects of gravitational acceleration on an object thrown upward.

### Example Box 3.2

#### Sample Exercise: Throwing a Ball Downward

A ball is thrown downward with an initial velocity of  $+20 \text{ m/s}$ . \* Using the approximate value  $10 \text{ m/s}^2$  for the gravitational acceleration, find (a) the velocity and (b) the distance traveled at 1-s time intervals for the first 2 s of motion.

a.  $v_0 = 20 \text{ m/s}$   
 $a = 10 \text{ m/s}^2$   
 for  $t = 1 \text{ s}$   
 $v = v_0 + at$   
 $= 20 \text{ m/s} + (10 \text{ m/s}^2)(1 \text{ s})$   
 $= 20 \text{ m/s} + 10 \text{ m/s}$   
 $= 30 \text{ m/s}$

$t = 2 \text{ s}$   
 $v = 20 \text{ m/s} + (10 \text{ m/s}^2)(2 \text{ s})$   
 $= 20 \text{ m/s} + 20 \text{ m/s} = 40 \text{ m/s}$

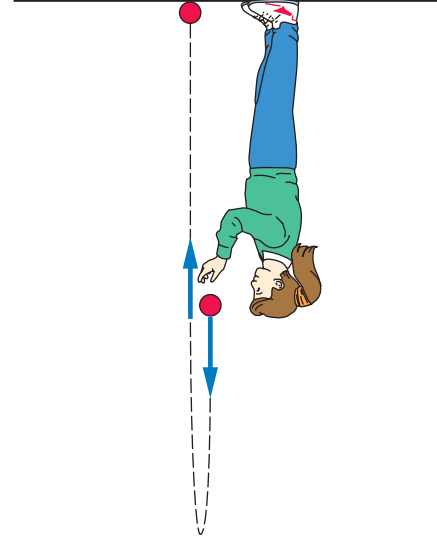
b.  $d = ?$   
 $d = v_0 t + \frac{1}{2}at^2$   
 $= (20 \text{ m/s})(1 \text{ s}) + \frac{1}{2}(10 \text{ m/s}^2)(1 \text{ s})^2$   
 $= 20 \text{ m} + 5 \text{ m} = 25 \text{ m}$

$t = 2 \text{ s}$   
 $d = (20 \text{ m/s})(2 \text{ s}) + \frac{1}{2}(10 \text{ m/s}^2)(2 \text{ s})^2$   
 $= 40 \text{ m} + 20 \text{ m} = 60 \text{ m}$

\*choosing downward as positive

### 3.3 Beyond Free Fall: Throwing a Ball Upward

In section 3.2, we discussed what happens when a ball is dropped or thrown downward. In both of these cases, the ball gains velocity as it falls due to the gravitational acceleration. What if the ball is thrown upward instead, as in figure 3.9? How does gravitational acceleration affect the ball's motion? What goes up must come down—but when and how fast are interesting questions with everyday applications.



**Figure 3.9** A ball thrown upward returns to the ground. What are the magnitude and direction of the velocity at different points in the flight?

The directions of the acceleration and velocity vectors merit our close attention. The gravitational acceleration is always directed downward toward the center of the Earth, because that is the direction of the gravitational force that produces this acceleration. This means that the acceleration is in the opposite direction to the original upward velocity.

#### How does the ball's velocity change?

Suppose we throw a ball straight up with an original velocity of  $20 \text{ m/s}$ . Many of us can throw a ball at this velocity: It is approximately  $45 \text{ MPH}$ . This is a lot slower than a  $90\text{-MPH}$  fastball, but throwing a ball upward with good velocity is harder than throwing it horizontally.

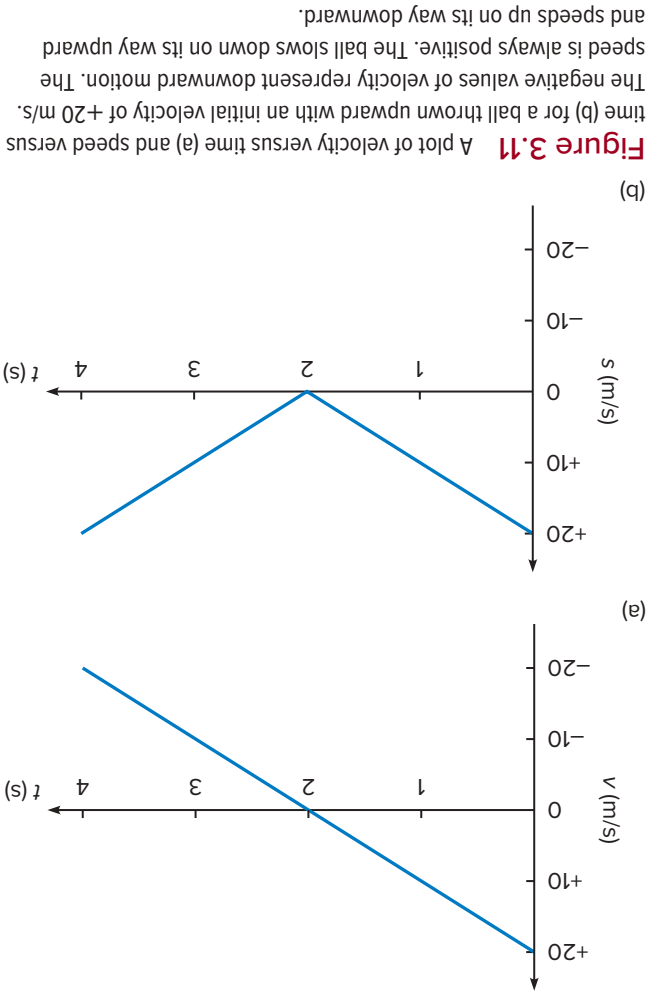
Once the ball leaves our hand, the primary force acting on it is gravity, which produces a downward acceleration of  $9.8 \text{ m/s}^2$  or approximately  $10 \text{ m/s}^2$ . (If we now choose the upward direction as positive, this acceleration is negative, because it is downward.) Every second, there is a change in velocity of  $10 \text{ m/s}$ . This change in velocity is directed downward, however, opposite the direction of the original velocity. It subtracts from the original velocity rather than adding to it. Once you are aware of how important direction is in observing the ball thrown upward, finding the velocity at different times is not hard. After  $1 \text{ second}$ , the velocity of the ball has decreased by  $10 \text{ m/s}$ , so if it started at  $+20 \text{ m/s}$  (choosing the positive direction to be upward in this case), it is now moving upward with a velocity of just  $+10 \text{ m/s}$ . After  $2 \text{ seconds}$ , it loses another  $10 \text{ m/s}$ , so its velocity is then zero. It does not stop there, of course. In another second ( $3 \text{ seconds}$  from the start), its velocity decreases by another  $10 \text{ m/s}$ , and it is then moving downward at  $-10 \text{ m/s}$ . The sign of the velocity indicates its direction. All of these values can be found from the relationship  $v = v_0 + at$ , where  $v_0 = +20 \text{ m/s}$  and  $a = -10 \text{ m/s}^2$ .

Clearly, the ball has changed direction, as you might expect. Just as before, the velocity changes steadily at  $-10 \text{ m/s}$  each second, due to the constant downward acceleration. After  $4 \text{ seconds}$ , the ball is moving downward with a velocity of  $-20 \text{ m/s}$  and is back at its starting position. These results are illustrated in figure 3.10. The high point in the motion occurs at a time  $2 \text{ seconds}$  after the ball is thrown, where the velocity is zero. If the velocity is zero, the ball is moving neither upward nor downward, so this is the turnaround point.

An interesting question, a favorite on physics tests (and often missed by students), asks for the value of acceleration at the high point in the motion. If the velocity is zero at this point, what is the value of the acceleration? The quick, but incorrect, response given by many people is that the acceleration must also be zero at that point. The correct answer is that the acceleration is still  $-10 \text{ m/s}^2$ . The gravitational acceleration is constant and does not change.

What if the acceleration were zero? That would imply the velocity was not changing. Because the instantaneous velocity is zero at the high point of the motion, it would remain zero. In other words, it would not move and would stay suspended at the top of the motion forever. When asked for a value of acceleration, we need to think about whether the velocity is





### Example Box 3.3

#### Sample Exercise: Throwing a Ball Upward

A ball is thrown upward with an initial velocity of +20 m/s.\* Find its estimated height at 1-s intervals for the first 5 s of its flight, using the approximate value of  $g = 10 \text{ m/s}^2$ .

$$d = ? \quad v = v_0 t + \frac{1}{2} a t^2$$

$$t = 1 \text{ s} \quad d = (20 \text{ m/s})(1 \text{ s}) + \frac{1}{2}(-10 \text{ m/s}^2)(1 \text{ s})^2 = 20 \text{ m} - 5 \text{ m} = 15 \text{ m}$$

$$t = 2 \text{ s} \quad d = (20 \text{ m/s})(2 \text{ s}) + \frac{1}{2}(-10 \text{ m/s}^2)(2 \text{ s})^2 = 40 \text{ m} - 20 \text{ m} = 20 \text{ m}$$

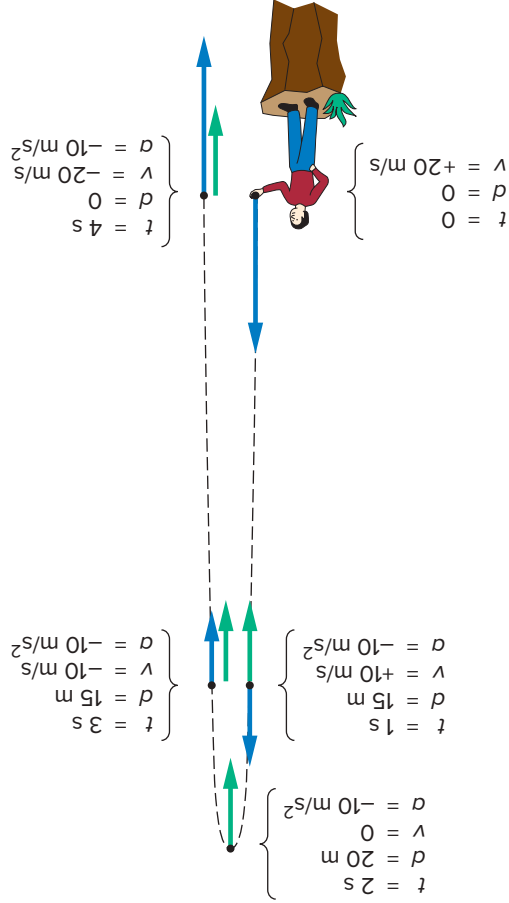
$$t = 3 \text{ s} \quad d = (20 \text{ m/s})(3 \text{ s}) + \frac{1}{2}(-10 \text{ m/s}^2)(3 \text{ s})^2 = 60 \text{ m} - 45 \text{ m} = 15 \text{ m}$$

$$t = 4 \text{ s} \quad d = (20 \text{ m/s})(4 \text{ s}) + \frac{1}{2}(-10 \text{ m/s}^2)(4 \text{ s})^2 = 80 \text{ m} - 80 \text{ m} = 0 \text{ m}$$

$$t = 5 \text{ s} \quad d = (20 \text{ m/s})(5 \text{ s}) + \frac{1}{2}(-10 \text{ m/s}^2)(5 \text{ s})^2 = 100 \text{ m} - 125 \text{ m} = -25 \text{ m}$$

\*choosing upward as positive

**Figure 3.10** The changing velocity in the flight of a ball thrown upward with a starting velocity of +20 m/s. The constant downward acceleration is shown as a green vector at each point.



changing. In this instant, the ball's velocity is still changing; from a positive to a negative value, even though the instantaneous velocity is zero. Acceleration is the *rate of change* of velocity and is *unrelated* to the size of the velocity. What would a graph of velocity plotted against time look like for the motion just described? If we make the upward direction of motion positive, the velocity starts with a value of +20 m/s and changes at a steady rate, decreasing by  $-10 \text{ m/s}$  each second. This is a straight-line graph, sloping downward, as in Figure 3.11. The positive values of velocity represent upward motion, where the size of the velocity is decreasing, and the negative values of velocity represent downward motion. If the ball did not hit the ground, but was thrown from the edge of a cliff, it would continue to gain negative velocity as it moved downward.

### How high does the ball go?

The position or height of the ball at different times can be computed using the methods in section 3.2. These distance computations involve the formula for uniform acceleration developed in section 2.5. In the sample exercise in example box 3.3, we compute the height or distance traveled at

1-second intervals for the ball thrown upward at  $+20\text{ m/s}$ , using  $-10\text{ m/s}^2$  for the gravitational acceleration.

What should you notice about these results? First, the high point of the motion is 20 meters above the starting point. The high point is reached when the velocity is zero, and we determined earlier that this occurs at a time of 2 seconds. This time depends on how fast the ball is thrown initially. The larger the original velocity, the greater the time to reach the high point. Knowing this time, we can use the distance formula to find the height.

You should also notice that after just 1 second, the ball has reached a height of 15 meters. It covers just 5 additional meters in the next second of motion, then falls back to 15 meters in the following second. The ball spends a full 2 seconds above the height of 15 meters, even though it reaches a height of only 20 meters. The ball is moving more slowly near the top of its flight than it is at lower points—this is why the ball appears to “hang” near the top of its flight.

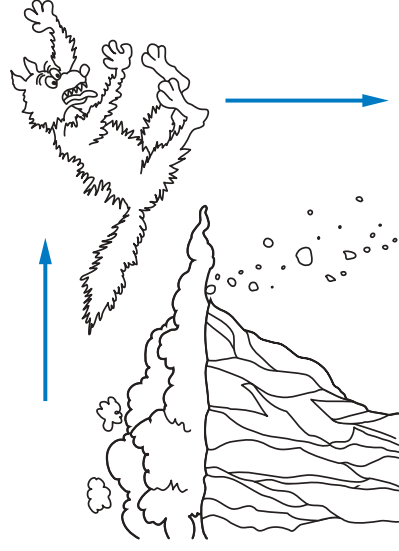
Finally, the time the ball takes to fall back to its starting point from the high point is equal to the time it takes to reach the high point in the first place. It takes 2 seconds to reach the high point and another 2 seconds to return to the starting point. (For times greater than 4 seconds, the distance  $d$  becomes negative, indicating the ball is now below its starting point.) The total time of flight to return to the starting point is just twice the time needed to reach the high point. In this case, 4 seconds is the total time in the air. A larger starting velocity would produce a higher turnaround point and a greater “hang time” for the ball.

A ball thrown upward is slowed by the constant downward gravitational acceleration until its velocity is reduced to zero at the high point. Remember that although the velocity is zero at the high point, the gravitational acceleration is not; it remains constant. The ball then falls from that high point, accelerating downward at the same constant rate as when it was rising. The ball travels more slowly near the top of its flight, so it appears to “hang” there. It spends more time in the top few meters than it does in the rest of the flight. We will find that these features are also present when a ball is projected at an angle to the horizontal, as discussed in section 3.5.

### 3.4 Projectile Motion

Suppose that instead of throwing a ball straight up or down, you throw it horizontally from some distance above the ground. What happens? Does the ball go straight out until it loses all of its horizontal velocity and then starts to fall, like the perplexed coyote in the *Roadrunner* cartoons (fig. 3.12)? What does the real path, or **trajectory**, look like?

Cartoons give us a misleading impression. In fact, two different things are happening at the same time: (1) The ball is accelerating downward under the influence of gravity, and (2) the ball is also moving sideways with an approximately



**Figure 3.12** A cartoon coyote falling off a cliff. Is this a realistic picture of what happens?

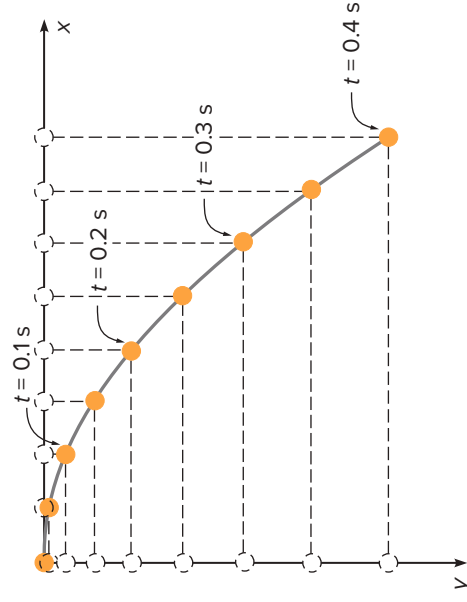
constant horizontal velocity. Combining these two motions gives the overall trajectory.

#### What does the trajectory look like?

You can perform a simple experiment to help you visualize the trajectory that the projectile follows. Roll a marble or small ball along the top of a desk or table, and let it roll off the edge. What does the trajectory of the ball look like as it travels through the air to the floor? Is it like the coyote in figure 3.12? Roll the ball at different velocities and see how the trajectory changes. Try to sketch the trajectory after making these observations.

How do we go about analyzing this motion? The key lies in thinking about the horizontal and vertical components of the motion separately and then combining them to get the actual trajectory (fig. 3.13).

The acceleration of the horizontal motion is zero, provided that air resistance is small enough to be ignored. This implies that the ball moves with a constant horizontal velocity once it has rolled off the table or has left the hand. The ball travels equal horizontal distances in equal time



**Figure 3.13** The horizontal and vertical motions combine to produce the trajectory of the projected ball. The vertical and horizontal positions are shown at regular time intervals.

intervals, as shown across the top of figure 3.13. In constructing this diagram, we assume an initial horizontal velocity of 2 m/s for the ball. Every tenth of a second, then, the ball travels a horizontal distance of 0.2 meter.

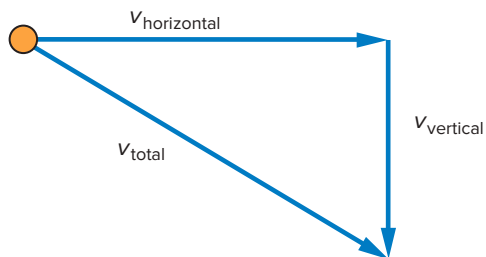
At the same time that the ball travels with constant horizontal velocity, it accelerates downward with the constant gravitational acceleration  $g$ . Its vertical velocity increases exactly like that of the falling ball photographed for figure 3.3. This motion is depicted along the left side of figure 3.13. In each successive time interval, the ball falls a greater distance than in the time interval before, because the vertical velocity increases with time.

Combining the horizontal and vertical motions, we get the trajectory shown curving downward in figure 3.13. For each time shown, we draw a horizontal dashed line locating the vertical position of the ball and a vertical dashed line for the horizontal position. The position of the ball at any time is the point where these lines intersect. The resulting trajectory (the solid curve) should look familiar if you have performed the simple experiments suggested in the first paragraph in this section.

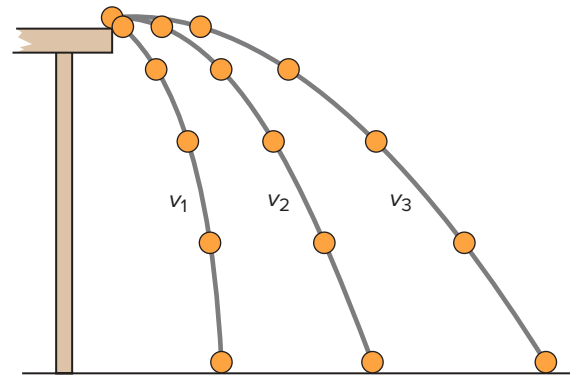
If you understand how we obtained the trajectory of the ball, you are well on your way to understanding **projectile motion**. The total velocity of the ball at each position pictured is in the direction of the trajectory at that point, because this is the actual direction of the ball's motion. This total velocity is a vector sum of the horizontal and vertical components of the velocity (fig. 3.14). (See appendix C for a discussion of vector components.) The horizontal velocity remains constant, because there is no acceleration in that direction. The downward (vertical) velocity gets larger and larger.

## Study Hint

If you are not familiar with vectors, you should take the time to read and do the exercises in appendix C. Appendix C describes what vectors are, how they are added using simple graphical procedures, and how vector components are defined. In this section, we use the ideas that a vector quantity such as velocity can have both horizontal and vertical components and that these components add up to give the total velocity. These concepts are critical to your understanding of projectile motion. Vector addition and vector components are also used in many other situations we will encounter in later chapters.



**Figure 3.14** The total velocity at any point is found by adding the vertical component of the velocity to the horizontal component.



**Figure 3.15** Trajectories for different initial velocities of a ball rolling off a table:  $v_3$  is larger than  $v_2$ , which in turn is larger than  $v_1$ . The positions are shown at equal time intervals.

The actual shape of the trajectory followed by the ball depends on the original horizontal velocity given the ball by throwing it or rolling it from the tabletop. If this initial horizontal velocity is small, the ball does not travel very far horizontally. Its trajectory will then be like the smallest starting velocity  $v_1$  in figure 3.15.

The three trajectories shown in figure 3.15 have three different starting velocities. As you would expect, the ball travels greater horizontal distances when projected with a larger initial horizontal velocity.

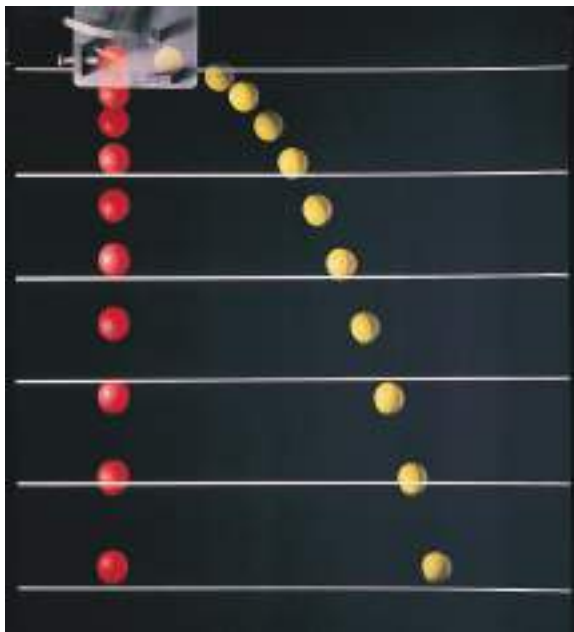
## What determines the time of flight?

Which of the three balls in figure 3.15 would hit the floor first if all three left the tabletop at the same time? Does the time taken for the ball to hit the floor depend on its horizontal velocity? There is a natural tendency to think that the ball that travels farther takes a longer time to reach the floor.

In fact, the three balls should all reach the floor at the same time. The reason is that they are all accelerating downward at the same rate of  $9.8 \text{ m/s}^2$ . This downward acceleration is not affected by how fast the balls travel horizontally. The time taken to reach the floor for the three balls in figure 3.15 is determined strictly by how high above the floor the tabletop is. The vertical motion is *independent* of the horizontal velocity.

This fact often surprises people. It contradicts our intuitive sense of what is going on but can be confirmed by doing simple experiments using two similar balls (fig. 3.16). If you throw one ball horizontally at the same time that you simply drop the second ball from the same height, the two balls should reach the floor at roughly the same time. They may fail to hit at the same time, but this is likely because it is hard to throw the first ball completely horizontally and to release both balls at the same time. A special spring gun, often used in demonstrations, can do this more precisely.

If we know how far a ball falls, we can compute the time of flight. This can then be used to determine the horizontal distance the ball will travel, if we know the initial horizontal velocity. The sample exercise in example box 3.4 shows this type of analysis. Notice that the horizontal distance traveled is determined by two factors: the time of flight and the initial velocity.



**Figure 3.16** A ball is dropped at the same time that a second ball is projected horizontally from the same height. Which ball reaches the floor first?  
Richard Megna/Fundamental Photographs, NYC

Treating the vertical motion independently of the horizontal motion and then combining them to find the trajectory is the secret to understanding projectile motion. A horizontal glide combines with a vertical plunge to produce a graceful curve. The downward gravitational acceleration behaves the same as for any falling object, but there is no acceleration in the horizontal direction if air resistance can be ignored. The projectile moves with constant horizontal velocity while it is accelerating downward.

### Example Box 3.4

#### Sample Exercise: Projectile Motion

A ball rolls off a tabletop with an initial velocity of 3 m/s. If the tabletop is 1.25 m above the floor,

- a. Estimate the time it takes for the ball to hit the floor (using the approximate value of  $g = 10 \text{ m/s}^2$ )?
  - b. How far does the ball travel horizontally?
- a. In figure 3.7, we saw that a ball will fall a distance of 1.25 m in approximately half a second. This can be found directly in this way:

$$d_{\text{vertical}} = 1.25 \text{ m} \qquad d_{\text{vertical}} = \frac{1}{2}at^2$$

$$a = g = 10 \text{ m/s}^2 \qquad \text{Solving for } t^2:$$

$$t = ? \qquad t^2 = \frac{d}{\frac{1}{2}a}$$

$$= \frac{1.25 \text{ m}}{5 \text{ m/s}^2}$$

$$= 0.25 \text{ s}^2$$

Taking the square root to get  $t$ :

$$t = 0.5 \text{ s}$$

- b. Knowing the time of flight  $t$ , we can now compute the horizontal distance traveled:

$$v_0 = 3 \text{ m/s} \qquad d_{\text{horizontal}} = v_0t$$

$$t = 0.5 \text{ s} \qquad = (3.0 \text{ m/s})(0.50 \text{ s})$$

$$d_{\text{horizontal}} = ? \qquad = 1.5 \text{ m}$$

### 3.5 Hitting a Target

As long as humans have been hunters or warriors, they have wanted to predict where a projectile such as a cannonball will land after it is fired. Being able to hit a target such as a bird in a tree or a ship at sea has obvious implications for survival. Being able to hit a catcher’s mitt with a baseball thrown from center field is also a highly valued skill.

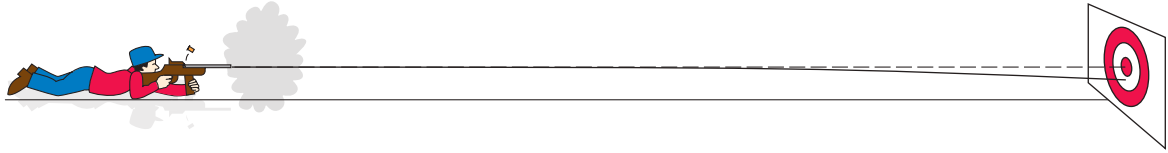
#### Does the bullet fall when a rifle is fired?

Imagine you are firing a rifle at a small target some distance away, with the rifle and target at exactly the same distance above the ground (fig. 3.17). If the rifle is fired directly at the target in a horizontal direction, will the bullet hit the center of the target? If you think of the ball rolling off the table in section 3.4, you should conclude that the bullet will strike the target slightly below the center. Why? The bullet will be accelerated downward by Earth’s gravitational pull and will fall slightly as it travels to the target.

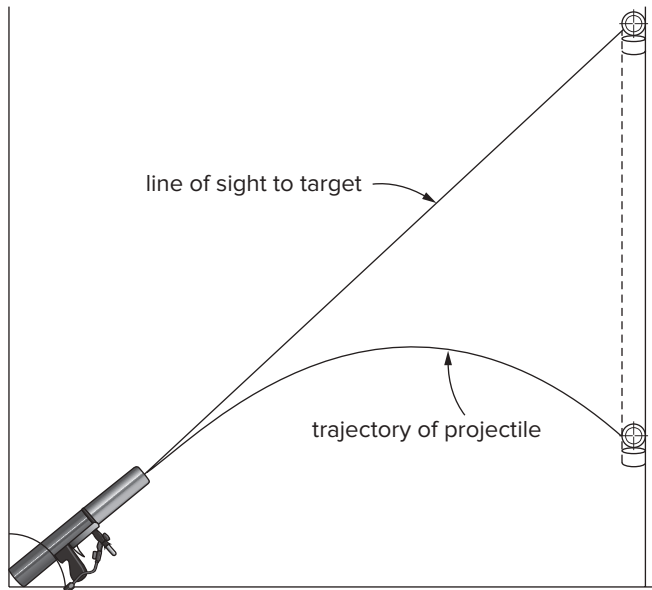
Because the time of flight is small, the bullet does not fall very far, but it falls far enough to miss the center of the target. How do you compensate for the fall of the bullet? You aim a little high. You correct your aim either through trial and error or by adjusting your rifle sight, so that your aim is automatically a little above center. Rifle sights are often adjusted for some average distance to the target. For longer distances you must aim high, for shorter distances a little low.

If you aim a little high, the bullet no longer starts out in a completely horizontal direction. The bullet travels up slightly during the first part of its flight and then comes down to meet the target. This also happens when you fire a cannon or throw a ball at a distant target.

A frequently used demonstration to illustrate the independence of the vertical and horizontal motions of projectiles is referred to as “Shoot the Monkey” or “Monkey in a Tree.” A projectile is aimed directly at a toy monkey (or other suitable target) hanging from the ceiling. An electronic trigger allows the target to drop at the same time the projectile is launched. The target falls straight down at a rate governed by the acceleration of gravity. The projectile starts to move toward



**Figure 3.17** A target shooter fires at a distant target. The bullet falls as it travels to the target.



**Figure 3.18** If the projectile is launched at the same time the target is dropped, will it hit the target?

the initial position of the target but also starts to fall at a rate governed by the acceleration of gravity.

Due to the fact that both the projectile and the target begin falling in the vertical direction at exactly same time and with the same downward acceleration, the projectile will always hit the target (fig. 3.18). It is crucial to recognize that the projectile hits below where it was aimed by an amount equal to the vertical distance the target drops, because the acceleration of gravity has the same effect on both the projectile and the target. It is also important that the target is released and the projectile is fired *at exactly the same time*.

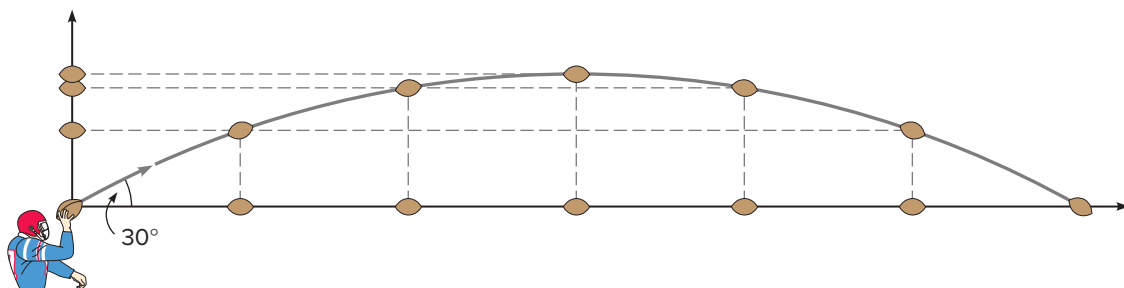
If the target were stationary, the projectile would have to be aimed above the target to compensate for the vertical drop due to the acceleration of gravity.

### The flight of a football

Whenever you throw a ball, such as a football, at a somewhat distant target, the ball must be launched at an angle above the horizontal, so that the ball does not fall to the ground too soon. A good athlete does this automatically as a result of practice. The harder you throw, the less you need to direct the ball upward, because a larger initial velocity causes the ball to reach the target more quickly, giving it less time to fall.

Figure 3.19 shows the flight of a football thrown at an angle of  $30^\circ$  above the horizontal. The vertical position of the ball is plotted on the left side of the diagram, as in figure 3.13 for the horizontally projected ball. The horizontal position of the ball is shown across the bottom of the diagram. We have assumed that air resistance is small, so the ball travels with a constant horizontal velocity. Combining these two motions yields the overall trajectory.

As the football climbs, the vertical component of its velocity decreases because of the constant downward gravitational acceleration. At the high point, this vertical component of the velocity is zero, just as it is for a ball thrown straight upward. The velocity of the ball is completely horizontal at this high point. The ball then begins to fall, gaining downward velocity as it accelerates. Unlike the ball thrown straight upward, however, there is a constant horizontal component to the velocity throughout the flight. The horizontal component is not zero at the top. We need to add this horizontal motion to the up-and-down motion described in section 3.3.



**Figure 3.19** The flight of a football launched at an angle of  $30^\circ$  to the horizontal. The vertical and horizontal positions of the ball are shown at regular time intervals.



## Everyday Phenomenon

## Box 3.2

**Shooting a Basketball**

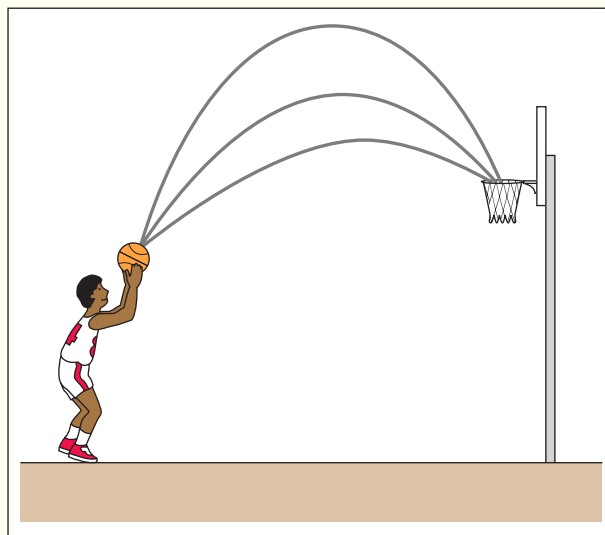
**The Situation.** Whenever you shoot a basketball, you unconsciously select a trajectory for the ball that you believe will have the greatest likelihood of getting the ball to pass through the basket. Your target is above the launch point (with the exception of dunk shots and sky hooks), but the ball must be on the way down for the basket to count.

What factors determine the best trajectory? When is a high, arching shot desirable, and when might a flatter trajectory be more effective? Will these factors be different for a free throw than for a shot taken when you are guarded by another player? How can our understanding of projectile motion help us answer these questions?

**The Analysis.** The diameter of the basketball and the diameter of the basket opening limit the angle at which the basketball can pass cleanly through the hoop. The second drawing shows the range of possible paths for a ball coming straight down and for one coming in at a  $45^\circ$  angle to the basket. The shaded area in each case shows how much the center of the ball can vary from the center line if the ball is to pass through the hoop. As you can see, a wider range of paths is available when the ball is coming straight down. The diameter of the basketball is a little more than half the diameter of the basket.

The second drawing illustrates the advantage of an arched shot. There is a larger margin of error in the path that the ball can take and still pass through the hoop cleanly. For the

dimensions of a regulation basketball and basket, the angle must be at least  $32^\circ$  for a clean shot. As the angle gets larger, the range of possible paths increases. At smaller angles, appropriate spin on the basketball will sometimes cause the ball to rattle through, but the smaller the angle, the less the likelihood of that happening.



Different possible trajectories for a basketball free throw. Which has the greatest chance of success?

(continued)

In throwing a ball, you can vary two quantities to help you hit your target. One is the initial velocity, which is determined by how hard you throw the ball. The other is the launch angle, which can be varied to fit the circumstances. A ball thrown with a large initial velocity does not have to be aimed as high and will reach the target more quickly. It may not clear the onrushing linemen, however, and it might be difficult to catch because of its large velocity.

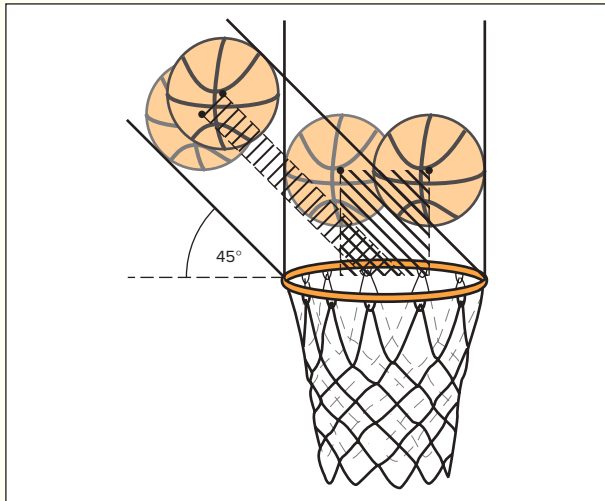
There is no time like the present to test these ideas. Take a page of scrap paper and crumple it into a compact ball. Then, put your wastebasket on your chair or desk. Throwing underhand, experiment with different throwing speeds and launch angles to see which is most effective in making a basket. Try to get a sense of how the launch angle and throwing speed interact to produce a successful shot. A low, flat-trajectory shot should require a greater throwing speed than a higher, arching shot. The flatter shot must also be aimed more accurately, because the effective area of the opening in

the basket is smaller when the ball approaches at a flat angle. The ball “sees” a smaller opening. (This effect is discussed in everyday phenomenon box 3.2.)

**How can we achieve maximum distance?**

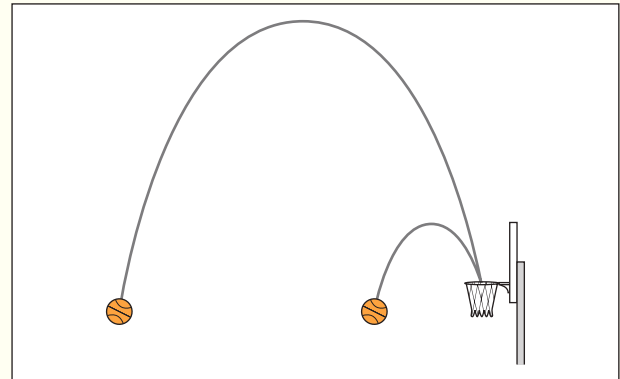
In firing a rifle or cannon, the initial velocity of the projectile is usually set by the amount of gunpowder in the shell. The launch angle is then the only variable we can change in attempting to hit a target. Figure 3.20 shows three possible trajectories for a cannonball fired at different launch angles for the same initial speed. For different launch angles, we tilt the cannon barrel by different amounts from the position shown.

Note that the greatest distance is achieved using an intermediate angle—an angle of  $45^\circ$  if the effects of air resistance are negligible. The same considerations are involved in the shot put in track-and-field events. The launch angle is



Possible paths for a basketball coming straight down and for one coming in at a  $45^\circ$  angle. The ball coming straight down has a wider range of possible paths.

The disadvantage of the arched shot is less obvious. As you get farther away from the basket, launching conditions for an arched shot must be more precise for the ball to travel the horizontal distance to the basket. If an arched shot is launched from 30 ft, it must travel a much higher path than a shot launched at the same angle closer to the basket, as shown in the third drawing. Because the ball stays in the air for a longer time, small variations in either the release speed or the angle can cause large errors in the distance traveled. This distance depends on both the time of flight and the horizontal component of the velocity.



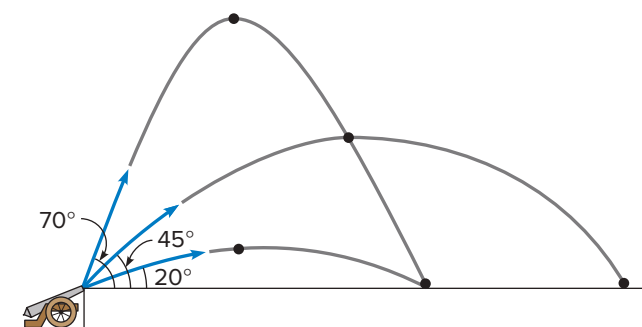
An arched shot launched from a large distance stays in the air longer than one launched at the same angle from much closer to the basket.

A highly arched shot is more effective when you are close to the basket. You can then take advantage of the greater range of paths available to the arched shot without suffering much from the uncertainty in the horizontal distance. Away from the basket, the desirable trajectories gradually become flatter, permitting more accurate control of the shot. An arched shot is sometimes necessary from anywhere on the court, however, to avoid having the shot blocked.

The spin of the basketball, the height of the release, and other factors all play a role in the success of a shot. A fuller analysis can be found in an article by Peter J. Brancazio in the *American Journal of Physics* (April 1981) entitled "Physics of Basketball." A good understanding of projectile motion might improve the game of even an experienced player.

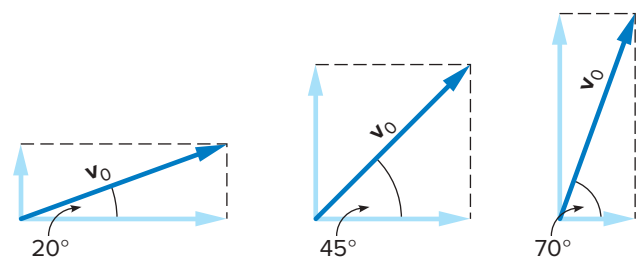
very important and, for the greatest distance, will be near  $45^\circ$ . Air resistance and the fact that the shot hits the ground below the launch point are also factors, so the most effective angle is somewhat less than  $45^\circ$  in the shot put.

Thinking about what happens to the horizontal and vertical components of the initial velocity at different launch



**Figure 3.20** Cannonball paths for different launch angles but the same initial launch speed.

angles will show us why the angle for maximum distance is approximately  $45^\circ$ . (See fig. 3.21.) Velocity is a vector, and its horizontal and vertical components can be found by drawing the vector to scale and adding dashed lines to the horizontal and vertical directions (fig. 3.21). This process is described more fully in appendix C.



**Figure 3.21** Vector diagrams showing the horizontal and vertical components of the initial velocity for the three cases illustrated in figure 3.20.

For the lowest launch angle of  $20^\circ$ , we see that the horizontal component of the velocity is much larger than the vertical. Because the initial upward velocity is small, the ball does not go very high. Its time of flight is short, and it hits the ground sooner than in the other two cases shown. The ball gets there quickly because of its large horizontal velocity and short travel time, but it does not travel very far before hitting the ground.

The high launch angle of  $70^\circ$  produces a vertical component much larger than the horizontal component. The ball thus travels much higher and stays in the air for a longer time than at  $20^\circ$ . It does not travel very far horizontally, however, because of its small horizontal velocity. The ball travels the same horizontal distance as for the  $20^\circ$  launch, but it takes longer getting there.\* (If we shot it straight up, the horizontal distance covered would be zero, of course.)

The intermediate angle of  $45^\circ$  splits the initial velocity into equal-sized horizontal and vertical components. The ball therefore stays in the air longer than in the low-angle launch but also travels with a greater horizontal velocity than in the high-angle launch. In other words, with relatively large values for both the vertical and horizontal components

\*The angles  $20^\circ$  and  $70^\circ$  are complementary, because their sum is  $90^\circ$ . Any pair of complementary launch angles ( $30^\circ$  and  $60^\circ$ , for example) yields the same horizontal range as each other.

of velocity, the vertical motion keeps the ball in the air long enough for the horizontal velocity to be effective. This produces the greatest distance of travel.

The time of flight and the horizontal distance traveled can be found if the launch angle and the size of the initial velocity are known. It is first necessary to find the horizontal and vertical components of the velocity to do these computations, however, and this makes the problem more complex than those discussed earlier. The ideas can be understood without doing the computations. The key is to think about the vertical and horizontal motions separately and then combine them.

For a projectile launched at an angle, the initial velocity can be broken down into vertical and horizontal components. The vertical component determines how high the object will go and how long it stays in the air, while the horizontal component determines how far it will go in that time. The launch angle and the initial speed interact to dictate where the object will land. Through the entire flight, the constant downward gravitational acceleration is at work, but it changes only the vertical component of the velocity. Producing or viewing such trajectories is a common part of our everyday experience.

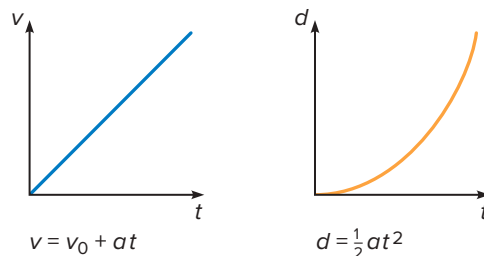
## Summary

The primary aim in this chapter has been to introduce you to the gravitational acceleration for objects near the Earth's surface and to show how that acceleration affects the motion of objects dropped or launched in various ways.

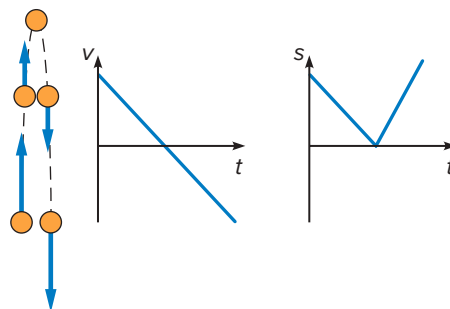
**1 Acceleration due to gravity.** To find the acceleration due to gravity, we use measurements of the position of a dropped object at different times. The gravitational acceleration is  $9.8 \text{ m/s}^2$ . It does not vary with time as the object falls, and it has the same value for different objects regardless of their weight.



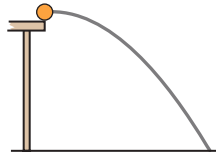
**2 Tracking a falling object.** The velocity of a falling object increases by approximately  $10 \text{ m/s}$  every second of its fall. Distance traveled increases in proportion to the square of the time, so that it increases at an ever-increasing rate. In just 1 second, a dropped ball is moving with a velocity of  $10 \text{ m/s}$  and has traveled 5 meters.



**3 Beyond free fall: Throwing a ball upward.** The speed of an object thrown upward first decreases due to the downward gravitational acceleration, passes through zero at the high point, and then increases as the object falls. The object spends more time near the top of its flight, because it is moving more slowly there. If we choose the upward direction as positive, the velocity values change from positive to negative as the ball changes direction.

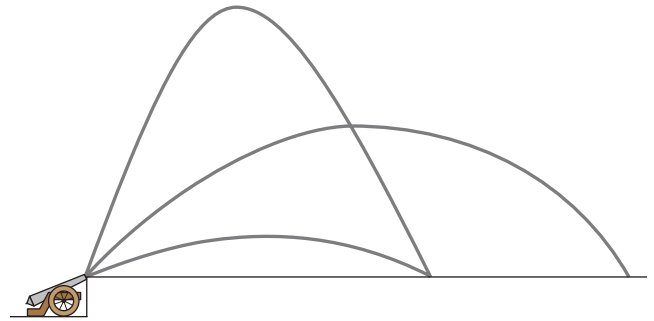


**4 Projectile motion.** If an object is launched horizontally, it moves with a constant horizontal velocity at the same time it accelerates downward due to gravity. These two motions combine to produce the object's curved trajectory.



**5 Hitting a target.** Two factors, the launch speed and the launch angle, can be varied to determine the path of an object launched at an angle to the horizontal. Once again, the horizontal

and vertical motions combine to produce the overall motion as the projectile moves toward a target.



One of the key points of this chapter is that you can't turn off gravity. Therefore, the acceleration in the downward vertical direction remains the same all the time! Try your hand at the mastery quizzes in Connect. They will give you some useful practice at clarifying these ideas.

## Key Terms

Acceleration due to gravity, 41

Air resistance, 41

Free fall, 44

Trajectory, 48

Projectile motion, 49

## Conceptual Questions

\* = more open-ended questions, requiring lengthier responses, suitable for group discussion

Q = sample responses are available in appendix D

Q = sample responses are available in Connect

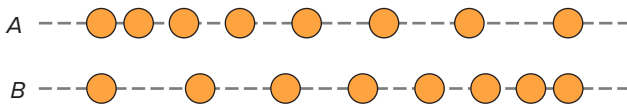
Q1. A small piece of paper is dropped and flutters to the floor. Is the piece of paper accelerating at any time during this motion? Explain.

Q2. The diagram shows the positions at intervals of 0.10 second of a ball moving from left to right (as in a photograph taken with a stroboscope that flashes every tenth of a second). Is the ball accelerated? Explain.



Q2 Diagram

Q3. The diagram shows the positions at intervals of 0.05 second of two balls moving from left to right. Is either or both of these balls accelerated? Explain.



Q3 Diagram

Q4. A lead ball and an aluminum ball, each 1 inch in diameter, are released simultaneously and allowed to fall to the ground. Due to its greater density, the lead ball has a substantially larger mass than the aluminum ball. Which of these balls, if either, has the greater acceleration due to gravity? Explain.

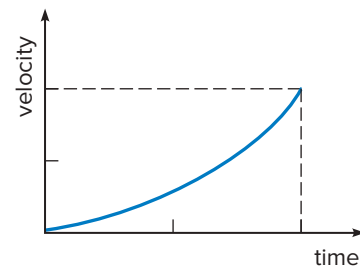
Q5. Two identical pieces of paper, one crumpled into a ball and the other left uncrumpled, are released simultaneously from the same height above the floor. Which one, if either, do you expect to reach the floor first? Explain.

Q6. Two identical pieces of paper, one crumpled into a ball and the other left uncrumpled, are released simultaneously from inside the top of a large evacuated tube. Which one, if either, do you expect will reach the bottom of the tube first? Explain.

\*Q7. Aristotle stated that heavier objects fall faster than lighter objects. Was Aristotle wrong? In what sense could Aristotle's view be considered correct?

Q8. A rock is dropped from the top of a diving platform into the swimming pool below. Will the distance traveled by the rock in a 0.1-second interval near the top of its flight be the same as the distance covered in a 0.1-second interval just before it hits the water? Explain.

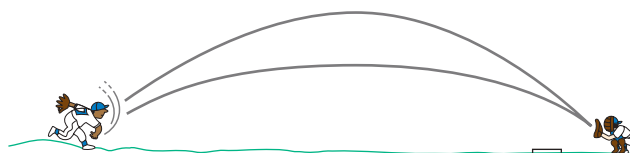
Q9. The graph shows the velocity plotted against time for a certain falling object. Is the acceleration of this object constant? Explain.



Q9 Diagram

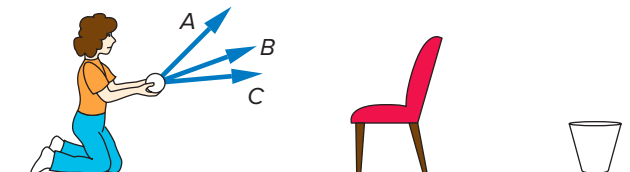
- Q10. If cars are traveling on a highway at constant speed, what is the advantage, if any, of remaining more than a car length behind the car in front of you? Explain. (See everyday phenomenon box 3.1.)
- Q11. If an object is in free fall, what forces are acting on it? (See everyday phenomenon box 3.1.)
- Q12. A ball is thrown downward with a large starting velocity.
- Will this ball reach the ground sooner than one that is just dropped at the same time from the same height? Explain.
  - Will this ball accelerate more rapidly than one that is dropped with no initial velocity? Explain.
- Q13. A ball thrown straight upward moves initially with a decreasing upward velocity. What are the directions of the velocity and acceleration vectors during this part of the motion? Does the acceleration decrease also? Explain.
- Q14. A rock is thrown straight upward, reaching a height of 20 meters. On its way up, does the rock spend more time in the top 5 meters of its flight than in the first 5 meters of its flight? Explain.
- Q15. A ball is thrown straight upward and then returns to the Earth. Choosing the positive direction to be upward, sketch a graph of the velocity of this ball against time. Where does the velocity change direction? Explain. Indicate this point on your graph.
- Q16. A ball is thrown straight upward and then returns to the Earth. Sketch a graph of the speed (not velocity) of this ball against time. Where does the direction of the ball's motion change? Explain. Indicate this point on your graph. Compare your graph to the graph of velocity versus time from question 15.
- Q17. A ball is thrown straight upward. At the very top of its flight, the velocity of the ball is zero. Is its acceleration at this point also zero? Explain.
- Q18. A ball is thrown straight upward and then returns to the Earth. Does the acceleration change direction during this motion? Explain.
- \*Q19. A ball rolls up an inclined plane, slows to a stop, and then rolls back down. Do you expect the acceleration to be constant during this process? Is the velocity constant? Is the acceleration equal to zero at any point during this motion? Explain.
- Q20. A ball rolls rapidly along a tabletop, off its edge, and then to the floor. At the instant the ball leaves the edge of the table, a second ball is dropped from the same height. Which ball, if either, reaches the floor first? Explain.
- Q21. For the two balls in question 20, which, if either, has the larger total velocity when it hits the floor? Explain.
- Q22. Is it possible for an object to have a horizontal component of velocity that is constant at the same time that the object is accelerating in the vertical direction? Explain by giving an example, if possible.
- Q23. A ball rolls off a table with a large horizontal velocity. Does the direction of the velocity vector change as the ball moves through the air? Explain.

- Q24. A ball rolls off a table with a horizontal velocity of 5 m/s. Is this velocity an important factor in determining the time it takes for the ball to hit the floor? Explain.
- Q25. An expert marksman aims a high-speed rifle directly at the center of a nearby target. Assuming that the rifle sight has been accurately adjusted for more distant targets, will the bullet hit the near target above or below the center? Explain.
- Q26. In the diagram, two different trajectories are shown for a ball thrown by a center fielder to home plate in a baseball game. Which of the two trajectories (if either), the higher one or the lower one, will result in a longer time for the ball to reach home plate? Explain.



Q26 Diagram

- Q27. For either of the trajectories shown in the diagram for question 26, is the velocity of the ball equal to zero at the high point in the trajectory? Explain.
- Q28. Assuming that the two trajectories in the diagram for question 26 represent throws by two different center fielders, which of the two is likely to have been thrown by the player with the stronger arm? Explain.
- Q29. A cannonball fired at an angle of  $70^\circ$  to the horizontal stays in the air longer than one fired at  $45^\circ$  from the same cannon. Will the  $70^\circ$  shot travel a greater horizontal distance than the  $45^\circ$  shot? Explain.
- Q30. Will a shot fired from a cannon at a  $20^\circ$  launch angle travel a longer horizontal distance than a  $45^\circ$  shot? Explain.
- Q31. The diagram shows a wastebasket placed behind a chair. Three different directions are indicated for the velocity of a ball thrown by the kneeling woman. Which of the three directions—A, B, or C—is most likely to result in the ball landing in the basket? Explain.



Q31 Diagram

- Q32. In the situation pictured in question 31, is the magnitude of the velocity important to the success of the shot? Explain.
- Q33. In shooting a free throw in basketball, what is the primary advantage that a high, arching shot has over one with a flatter trajectory? Explain. (See everyday phenomenon box 3.2.)
- Q34. In shooting a basketball from greater than free-throw range, what is the primary disadvantage of a high, arching shot? Explain. (See everyday phenomenon box 3.2.)
- \*Q35. A football quarterback must hit a moving target while eluding onrushing linemen. Discuss the advantages and disadvantages of a hard, low-trajectory throw over a higher-lofted throw.

## Exercises

For the exercises in this chapter, use the approximate value of  $g = 10 \text{ m/s}^2$  for the acceleration due to gravity.

- E1. A steel ball is dropped from a diving platform (with an initial velocity of zero). Using the approximate value of  $g = 10 \text{ m/s}^2$ ,
- What is the velocity of the ball 0.7 second after its release?
  - What is its velocity 1.4 seconds after its release?
- E2. A large rock is dropped from the top of a high cliff. Assuming that air resistance can be ignored and that the acceleration has the constant value of  $10 \text{ m/s}^2$ , how fast would the rock be traveling 6 seconds after it is dropped? What is this speed in MPH? (See conversion factors in appendix E.)
- E3. For the ball in exercise E1,
- Through what distance does the ball fall in the first 0.7 second of its flight? (Assume  $g = 10 \text{ m/s}^2$ .)
  - How far does it fall in the first 1.4 seconds of its flight?
- E4. Suppose Galileo's pulse rate was 75 beats per minute.
- How many beats per second is this?
  - What is the time in seconds between consecutive pulse beats?
  - How far (in meters) does an object fall in this time when dropped from rest?
  - What is this distance in feet (use the conversion factors in appendix E.)?
- E5. A ball is thrown downward with an initial velocity of 14 m/s. Using the approximate value of  $g = 10 \text{ m/s}^2$ , what is the velocity of the ball 3.0 seconds after it is released? (See example box 3.2.)
- E6. A ball is dropped from a high building. Using the approximate value of  $g = 10 \text{ m/s}^2$ , find the *change* in velocity between the first and sixth seconds of its flight.
- E7. A ball is thrown upward, from the ground, with an initial velocity of 13 m/s. Using the approximate value of  $g = 10 \text{ m/s}^2$ , what are the magnitude and direction of the ball's velocity (see example box 3.3)
- 1 second after it is thrown?
  - 2 seconds after it is thrown?
- E8. How high above the ground is the ball in exercise 7
- 1 second after it is thrown?
  - 2 seconds after it is thrown?
- E9. At what time does the ball in exercise E7 reach the high point in its flight? (Use the approximate value of  $g = 10 \text{ m/s}^2$ , and remember that the velocity is equal to zero at the highest point.)
- E10. Suppose that the gravitational acceleration on a certain planet is only  $4.0 \text{ m/s}^2$ . A space explorer standing on this planet throws a ball straight upward with an initial velocity of 17 m/s.
- What is the velocity of the ball 3 seconds after it is thrown?
  - How much time elapses before the ball reaches the high point in its flight?
- E11. A bullet is fired horizontally with an initial velocity of 800 m/s at a target located 200 m from the rifle.
- How much time is required for the bullet to reach the target?
  - Using the approximate value of  $g = 10 \text{ m/s}^2$ , how far does the bullet fall in this time?
- E12. A ball rolls off a shelf with a horizontal velocity of 3 m/s. At what horizontal distance from the shelf does the ball land if it takes 0.45 second to reach the floor?
- E13. A ball rolls off a table with a horizontal velocity of 3 m/s. If it takes 0.45 second for the ball to reach the floor, how high above the floor is the tabletop? (Use  $g = 10 \text{ m/s}^2$ .)
- E14. A ball rolls off a table with a horizontal velocity of 3 m/s to the right. If it takes 0.4 second for it to reach the floor,
- What is the downward component of the ball's velocity just before it hits the floor? (Use  $g = 10 \text{ m/s}^2$ .)
  - What is the horizontal component of the ball's velocity just before it hits the floor?
- E15. A ball rolls off a platform that is 3 meters above the ground. The ball's horizontal velocity as it leaves the platform is 5 m/s.
- How much time does it take for the ball to hit the ground? (See example box 3.4; use  $g = 10 \text{ m/s}^2$ .)
  - How far from the base of the platform does the ball hit the ground?
- E16. A projectile is fired at an angle such that the vertical component of its velocity and the horizontal component of its velocity are both equal to 50 m/s.
- Using the approximate value of  $g = 10 \text{ m/s}^2$ , how long does it take for the projectile to reach its high point?
  - What horizontal distance does the projectile travel in this time?

## Synthesis Problems

For the synthesis problems in Chapter 3, use the approximate value of  $g = 10 \text{ m/s}^2$  for the acceleration due to gravity. Ignore air resistance.

- SP1. A ball is thrown straight upward with an initial velocity of 18 m/s. Use  $g = 10 \text{ m/s}^2$  for computations listed here.
- What is its velocity at the high point in its motion?
  - How much time is required to reach the high point?
  - How high above its starting point is the ball at its high point?
  - How high above its starting point is the ball 3 seconds after it is released?
  - Is the ball moving up or down 2 seconds after it is released?
- SP2. Two balls are released simultaneously from the top of a tall building. Ball A is simply dropped with no initial velocity, and ball B is thrown downward with an initial velocity of 15 m/s.
- What are the velocities of the two balls 1.3 seconds after they are released?
  - How far has each ball dropped in 1.3 seconds?
  - Does the difference between the velocities of the two balls change at any time after their release? Explain.
- SP3. Two balls are rolled off a tabletop that is 0.7 m above the floor. Ball A has a horizontal velocity of 4 m/s, and that of ball B is 6 m/s.
- Assuming  $g = 10 \text{ m/s}^2$ , how long does it take each ball to reach the floor after it rolls off the edge?
  - How far does each ball travel horizontally before hitting the floor?

- c. If the two balls started rolling at the same time at a point 1.5 m behind the edge of the table, will they reach the floor at the same time? Explain.
- SP4. A cannon is fired over level ground at an angle of  $35^\circ$  to the horizontal. The initial velocity of the cannonball is 500 m/s, but because the cannon is fired at an angle, the vertical component of the velocity is 287 m/s and the horizontal component is 410 m/s.
- How long is the cannonball in the air? (Use  $g = 10 \text{ m/s}^2$  and the fact that the total time of flight is twice the time required to reach the high point.)
  - How far does the cannonball travel horizontally?
  - Repeat these calculations, assuming that the cannon was fired at a  $55^\circ$  angle to the horizontal, resulting in a vertical component of velocity of 410 m/s and a horizontal component of 287 m/s. How does the distance traveled compare to the earlier result? (See fig. 3.20.)
- SP5. An excellent major league pitcher can throw a baseball at a speed of 100 MPH. The pitcher's mound is approximately 60 ft from home plate.
- What is the speed in m/s?
  - What is the distance to home plate in meters?
  - How much time is required for the ball to reach home plate?
  - If the ball is launched horizontally, how far does the ball drop in this time, ignoring the effects of spin?
  - What is this distance in feet (this explains why the pitchers stand on a mound)?
- SP6. An archeologist is running at 8 m/s with her hands outstretched above her head (1.85 m from feet to fingertips) while being chased by a tiger. She runs exactly horizontally off the edge of a chasm and attempts to grab on to the opposite side.
- If the chasm is 5.0 meters wide, how long does she take to cover this distance?
  - During this time, what distance has she fallen vertically (use  $g = 10 \text{ m/s}^2$ )?
  - How far above or below the edge of the opposite side do her fingertips fall? (Use + to indicate distances above the edge, - to indicate distances below the edge.)

## Home Experiments and Observations

- HE1. Gather numerous small objects and drop them from equal heights, two at a time. Record which objects fall significantly more slowly than a compact, dense object such as a marble. Rank order these slower objects by their time of descent. What factors seem to be important in determining this time?
- HE2. Working with a partner, you can get an estimate of your reaction time by catching a falling meter stick. (See everyday phenomenon box 3.1.) Have your partner hold the meter stick from a point near the top while you place the finger and thumb of your catching hand about an inch apart on both sides of the 50-cm mark. Without giving any cues, your partner then drops the meter stick; when you see it move, react to catch it by closing your finger and thumb. Record the distance that the meter stick moves between the times that your partner releases it and you catch it.
- Repeat this process several times for each partner and compute the average distance the meter stick traveled for each partner. Tabulate your results.
  - Because the distance traveled in the time  $t$  that it takes for you to react is  $d = 1/2 gt^2$ , the time of travel is  $t = \sqrt{\frac{2d}{g}}$ . Use a calculator to compute the reaction time  $t$  for each partner from the average distance  $d$  (expressed in meters). Use  $g = 10 \text{ m/s}^2$ . How does your average reaction time compare to your partner's?
  - A "normal" reaction time is between 0.2 and 0.25 second. Is your reaction time close to this? If not, explain why you think your reaction time is different.
- HE3. Try dropping a ball from one hand at the same time you throw a second ball with your other hand. At first, try to throw the second ball horizontally, with no upward or downward component to its initial velocity. (It may take some practice.)
- Do the balls reach the floor at the same time? (It helps to enlist a friend for making this judgment.)
  - If the second ball is thrown slightly upward from the horizontal, which ball reaches the ground first?
  - If the second ball is thrown slightly downward from the horizontal, which ball reaches the ground first?
- HE4. Take a ball outside and throw it straight up in the air as hard as you can. By counting seconds, or by enlisting a friend with a watch, estimate the time that the ball remains in the air. From this information, can you find the initial velocity that you gave to the ball? (The time required for the ball to reach the high point is just half the total time of flight.)
- HE5. Take a stopwatch to a football game and estimate the hang time of several punts. Also note how far (in yards) each punt travels horizontally. Do the highest punts have the longest hang times? Do they travel the greatest distances horizontally?
- HE6. Using rubber bands and a plastic rule or other suitable support, design and build a marble launcher. By pulling the rubber band back by the same amount each time, you should be able to launch the marble with approximately the same speed each time. (*Warning:* Leave yourself ample room free of breakable objects!)
- Produce a careful drawing of your launcher and note the design features you used. (Prizes may be available for the best design.)
  - Placing your launcher at a number of different angles to the horizontal, launch marbles over a level surface and measure the distance they travel from the point of launch. Which angle yields the greatest distance?
  - Fire the marbles at different angles from the edge of a desk or table. Which angle yields the greatest horizontal distance?
- HE7. Try throwing a ball or wadded piece of paper into a wastebasket placed a few meters from your launch point.
- Which is most effective, an overhanded or underhanded throw? (Five practice shots followed by 10 attempts for each might produce a fair test.)
  - Repeat this process with a barrier such as a chair placed near the wastebasket.

# CHAPTER 4



Boonyarak Voranimmanont/Shutterstock

## Newton's Laws: Explaining Motion

### Chapter Overview

The primary purpose of this chapter is to explain Newton's three laws of motion and how they apply in familiar situations. We begin with a historical sketch of their development and then proceed to a careful discussion of each law. The concepts of force, mass, and weight play critical roles in this discussion. We conclude the chapter by applying Newton's theory to several familiar examples.

### Chapter Outline

- 1 A brief history.** Where do our ideas and theories about motion come from? What roles were played by Aristotle, Galileo, and Newton?
- 2 Newton's first and second laws.** How do forces affect the motion of an object? What do Newton's first and second laws of motion tell us, and how are they related to each other?
- 3 Mass and weight.** How can we define mass? What is the distinction between mass and weight?
- 4 Newton's third law.** Where do forces come from? How does Newton's third law of motion help us to define force, and how is the third law applied?
- 5 Applications of Newton's laws.** How can Newton's laws be applied in different situations, such as pushing a chair, skydiving, throwing a ball, and pulling two connected carts across the floor?



A large person gives you a shove, and you move in the direction of that push. A child pulls a toy wagon with a string, and the wagon lurches along. An athlete kicks a football or a soccer ball, and the ball is launched toward the goal. These are familiar examples involving forces in the form of pushes or pulls that cause changes in motion.

To pick a less complex example, imagine yourself pushing a chair across a wood or tile floor (fig. 4.1). Why does the chair move? Will it continue its motion if you stop pushing? What factors determine the velocity of the chair? If you push harder, will the chair's velocity increase? Up to this point, we have introduced ideas useful in describing motion, but we have not talked much about what causes changes in motion. Explaining motion is more challenging than describing it.

You already have some intuitive notions about what causes the chair to move. Certainly, the push you exert on the chair has something to do with it. But is the strength of that push more directly related to the velocity of the chair or to its acceleration? At this point, intuition often serves us poorly.

Over two thousand years ago, Greek philosopher Aristotle (384–322 B.C.) attempted to provide answers to some of these questions. Many of us would find that his explanations match our intuition for the case of the moving chair, but they are less satisfactory in the case of a thrown object where the push is not sustained. Aristotle's ideas were widely accepted until they were replaced by a theory introduced by Isaac Newton in the seventeenth century. Newton's theory of motion has proved to be a much more complete and satisfactory explanation of motion, and it permits quantitative predictions that were largely lacking in Aristotle's ideas.

Newton's three laws of motion form the foundation of his theory. What are these laws, and how are they used in explaining motion? How do Newton's ideas differ from those of Aristotle, and why do Aristotle's ideas often seem to fit our commonsense notions of what is happening? A good understanding of Newton's laws will permit you to analyze and



**Figure 4.1** Moving a chair. Will the chair continue to move when the person stops pushing?

*Keith Eng 2008*

explain almost any simple motion. This understanding will provide you with insights useful in driving a car, moving heavy objects, and many other everyday activities.

## 4.1 A Brief History

Did some genius, sitting under an apple tree, concoct a full-blown theory of motion in a sudden, blinding flash of inspiration? Not quite. The story of how theories are developed and gain acceptance involves many players over long periods of time.

Let's highlight the roles of a few key people whose insights produced major advances. A glimpse of this history can help you appreciate the physical concepts we will discuss by showing when and how the theories emerged. It is important, for example, to know whether a theory was just proposed yesterday or has been tried and tested over a long time. Not all theories carry equal weight in their acceptance and use by scientists. Aristotle, Galileo, and Newton were major players in shaping our views of the causes of motion.

### Aristotle's view of the cause of motion

Questions about the causes of motion and changes in motion perplexed philosophers and other observers of nature for centuries. For over a thousand years, Aristotle's views prevailed. Aristotle was a careful and astute philosopher of nature. Aristotle investigated an incredible range of subjects, and he (or perhaps his students) produced extensive writings on topics such as logic, metaphysics, politics, literary criticism, rhetoric, psychology, biology, and physics.

In his discussions of motion, Aristotle conceived of force much as we have talked about it to this point: as a push or pull acting on an object. He believed that a force had to act for an object to move and that the velocity of the object was proportional to the strength of the force. A heavy object would fall more quickly toward the Earth than a lighter object, because there was a larger force pulling the object to

the Earth. The strength of this force could be appreciated simply by holding the object in your hand.

Aristotle was also aware of the resistance that a medium offers the motion of an object. A rock falls more rapidly through air than through water. Water provides greater resistance to motion than air, as you surely know from trying to walk through waist-deep water at the beach. Aristotle thus saw the velocity of the object as being proportional to the force acting on it and inversely related to the resistance, but he never defined the concept of resistance quantitatively. He did not distinguish acceleration from velocity, and he spoke of velocity by stating the time required to cover a fixed distance.

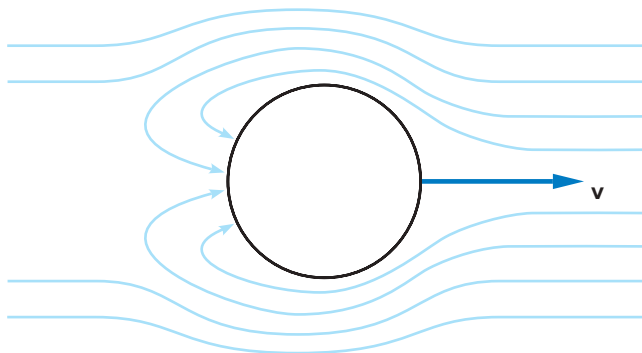
Aristotle was an observer of nature rather than an experimenter. He did not make quantitative predictions that he checked by experiment. Even without such tests, however, some problems with his basic ideas of motion troubled Aristotle himself, as well as later thinkers. For example, in the case of a thrown ball or rock, the force that initially propels the object no longer acts once the ball leaves the hand. What keeps the ball moving?

Because the ball does keep moving for some time after leaving the hand that throws it, a force was necessary, according to Aristotle's theory. He suggested that the force that maintains the motion once the ball leaves the hand is provided by air rushing around to fill the vacuum in the spot where the ball has just been (fig. 4.2). This flow of air then pushes the ball from behind. Does this seem reasonable?

Following the decline of the Roman Empire, only fragments of Aristotle's writings were known to European thinkers for several centuries. His complete works, which had been preserved by Arab scholars, did not resurface in Europe until the twelfth century. Along with the work of other Greek thinkers, Aristotle's works were translated into Latin during the twelfth and thirteenth centuries.

### How did Galileo challenge Aristotle's views?

By the time Italian scientist Galileo Galilei (1564–1642) came on the scene, Aristotle's ideas were well established at European universities, including the universities of Pisa and



**Figure 4.2** Aristotle pictured air rushing around a thrown object to continue pushing the object forward. Does this picture seem reasonable?

Padua, where Galileo studied and taught. In fact, education at the universities was organized around the disciplines defined by Aristotle, and much of Aristotle's natural philosophy had been incorporated into the teaching of the Roman Catholic Church. Italian theologian Thomas Aquinas had carefully interwoven Aristotle's thinking with the theology of the church.

To challenge Aristotle was equivalent to challenging the authority of the church and could carry heavy consequences. Galileo was not alone in questioning Aristotle's ideas on motion; others had noted that dropped objects of similar form but radically different weights fall at virtually the same rate, contrary to Aristotle's theory. Although Galileo may never have dropped objects from the Leaning Tower of Pisa, he did perform careful experiments with dropped objects and actively publicized his results.

Galileo's primary problems with the church came from advocating the ideas of Copernicus. Copernicus had proposed a sun-centered (*heliocentric*) model of the solar system (discussed in chapter 5), which opposed the prevailing Earth-centered models of Aristotle and others. Galileo was an activist on several fronts in challenging Aristotle and the traditional thinking. This placed him in conflict with many of his university colleagues and with members of the church hierarchy. He was eventually tried by the Inquisition and found guilty of heresy. He was placed under house arrest and forced to retract some of his teachings.

In addition to his work on falling objects, Galileo developed new ideas on motion that contradicted Aristotle's theory. Galileo argued that the natural tendency of a moving object is to continue moving: No force is required to maintain this motion. (Think about the pushed chair again. Does this statement make sense in that situation?) Building on the work of others, Galileo also developed a mathematical description of motion that included acceleration. The relationship  $d = \frac{1}{2} at^2$  for the distance covered by a uniformly accelerating object was carefully demonstrated by Galileo in experiments involving balls rolling down an inclined plane. He published many of these ideas near the end of his life in his famous *Dialogues Concerning Two New Sciences*.

### What did Newton accomplish?

Isaac Newton (1642–1727; fig. 4.3) was born in England within a year of Galileo's death in Italy. Building on the work of Galileo, he proposed a theory of the causes of motion that could explain the motion of any object—the motion of ordinary objects such as a ball or chair as well as the motion of heavenly bodies such as the moon and the planets. In the Greek tradition, celestial motions were thought of as in an entirely different realm from Earthbound motions, thus requiring different explanations. Newton abolished this distinction by explaining both terrestrial and celestial mechanics with one theory.

The central ideas in Newton's theory are his three laws of motion (discussed in sections 4.2 and 4.4) and his law of



**Figure 4.3** A portrait of Isaac Newton.  
Pixtal/age Fotostock

universal gravitation (discussed in chapter 5). Newton's theory provided successful explanations of aspects of motion already known, as well as offered a framework for many new studies in physics and astronomy. Some of these studies led to predictions of phenomena not previously observed. For example, calculations applying Newton's theory to irregularities in the orbits of the known planets led to the prediction of the existence of Neptune, which was quickly confirmed by observation. Confirmed predictions are one of the marks of a successful theory. Newton's theory served as the basic theory of mechanics for over two hundred years and is still used extensively in physics and engineering.

Newton developed the basic ideas of his theory around 1665, when he was still a young man. To avoid the plague, he had returned to his family's farm in the countryside, where he had time to engage in serious thought with little interruption. The story has it that seeing an apple fall led to his insight that the moon also falls toward the Earth and that the force of gravity is involved in both cases. (See chapter 5.) Flashes of insight or inspiration were surely a part of the process.

Although Newton developed much of his theory and its details in 1665, he did not formally publish his ideas until 1687. One reason for this delay was his need to develop some of the mathematical techniques required to calculate the effects of the proposed gravitational force on objects such as planets. (He is generally credited with being the co-inventor of what we now call *calculus*.) The English title of Newton's 1687 treatise is *The Mathematical Principles of Natural Philosophy* (*Philosophiæ Naturalis Principia*

*Mathematica* in Latin), which is often referred to as Newton's *Principia*. His development and use of calculus in physics are considered a major milestone.

Scientific theories like Newton's do not just emerge in an intellectual vacuum. They are products of both their time and the state of knowledge and current worldviews. They usually replace earlier and often cruder theories. The accepted theory of motion in Newton's day was still that of Aristotle, although it had come under attack by Galileo and others. Its shortcomings were generally recognized. Newton provided the capstone for a revolution in thought that was already well under way.

Although Aristotle's ideas on motion are now considered unsatisfactory and are worthless for making quantitative predictions, they do have an intuitive appeal much like that of our own untrained thinking about motion. For this reason, we often speak of the need to replace Aristotelian ideas about motion with Newtonian concepts as we learn mechanics. Even though our own naive ideas about motion are not usually as fully developed as those of Aristotle, you may find that some of your commonsense notions will require modification.

Newton's theory, in turn, has been partially superseded by more sophisticated theories that provide more accurate descriptions of motion. These include Einstein's theory of relativity and the theory of quantum mechanics, both of which arose early in the twentieth century. Although the predictions of these theories differ substantially from Newton's theory in the realm of the very fast (in the case of relativity) and the very small (quantum mechanics), they differ insignificantly for the motion of ordinary objects traveling at speeds much less than that of light. Newton's theory was a tremendous step forward and is still used extensively to analyze the motion of ordinary objects.

Aristotle's ideas on motion, although not capable of making quantitative predictions, provided explanations that were widely accepted for many centuries and that fit well with commonsense thinking. Galileo challenged Aristotle's ideas on free fall, as well as his general assumption that a force was required to keep an object in motion. Building on Galileo's work, Newton developed a more comprehensive theory of motion that replaced Aristotle's ideas. Newton's theory is still widely used to explain the motion of ordinary objects.

## 4.2 Newton's First and Second Laws

If we push a chair across the floor, what causes the chair to move or to stop moving? Newton's first two laws of motion address these questions and, in the process, provide part of a definition of **force**. The first law tells us what happens in the absence of a force, and the second describes the effects of applying a force to an object.

We discuss the first and second laws of motion together because the first law is closely related to the more general

second law. Newton felt the need to state the first law separately, however, to counter strongly held Aristotelian ideas about motion. In doing so, Newton was following the lead of Galileo, who had stated a principle similar to Newton's first law several years earlier.

### Newton's first law of motion

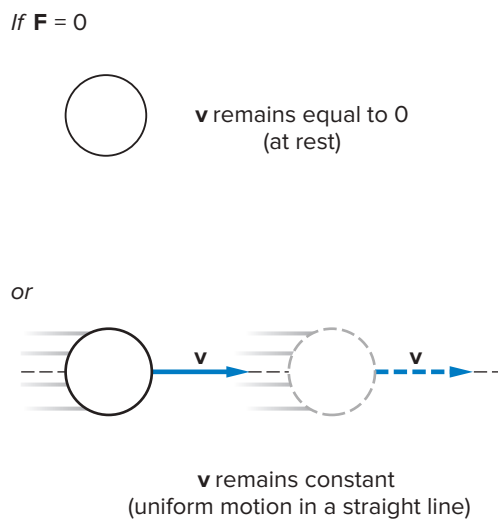
In language not too different from his own, **Newton's first law of motion** can be stated as follows:

An object remains at rest, or in uniform motion in a straight line, unless it is compelled to change by an externally imposed force.

In other words, unless there is a force acting on the object, its *velocity* will not change. If it is initially at rest, it will remain at rest; if it is moving, it will continue to do so with constant velocity (fig. 4.4). In essence, Newton was reinforcing one of Galileo's key ideas of motion in stating the first law.

Notice that in paraphrasing Newton's first law, we have used the term *velocity* rather than the term *speed*. Constant velocity implies that neither the direction nor the magnitude of the velocity changes. When the object is at rest, its velocity is zero, and that value remains constant in the absence of an external force. If there is no force acting on the object, the acceleration of the object is zero. The velocity does not change.

Although this law seems simple enough, it directly contradicts Aristotle's ideas (and perhaps your own intuition as well). Aristotle believed that a force is required to keep an object moving. His views make intuitive sense if we are talking about moving a heavy object, such as the chair mentioned in our introduction. If you stop pushing, the chair stops moving. This view encounters problems, however, if we consider the motion of a thrown ball, or even a chair moving on a slippery surface. These objects continue to move after the initial



**Figure 4.4** Newton's first law: In the absence of a force, an object remains at rest or moves with constant velocity.

push. Newton (and Galileo) made the strong statement that no force is needed to keep an object moving.

How can Aristotle's ideas be so different from those of Newton and Galileo and yet seem so reasonable in some situations? The key to answering that question involves the existence of resistive, or **frictional, forces**. The chair does not move far after you stop pushing because the frictional forces of the floor acting on the chair cause the velocity to quickly decrease to zero. A thrown ball would eventually stop moving, even if it did not fall to the ground, because the force of air resistance is pushing against it. It is quite difficult to find a situation in which there are *no* forces acting upon an object. Aristotle recognized the presence of air resistance and similar effects but did not treat them as forces in his theory.

### How is force related to acceleration?

**Newton's second law of motion** is a more complete statement about the effect of an imposed force on the motion of an object. Stated in terms of acceleration, it says

The acceleration of an object is directly proportional to the magnitude of the imposed force and inversely proportional to the mass of the object. The acceleration is in the same direction as that of the imposed force.

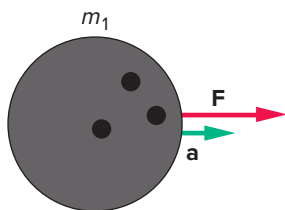
This statement is most easily grasped in symbolic form. By choosing appropriate units for force, we can state the proportionality of Newton's second law as the equation

$$\mathbf{a} = \frac{\mathbf{F}_{\text{net}}}{m}$$

where  $\mathbf{a}$  is the acceleration,  $\mathbf{F}_{\text{net}}$  is the total, or **net, force** acting on the object, and  $m$  is the mass of the object. Because the acceleration is directly proportional to the imposed force, if we double the force acting on the object, we double the acceleration of the object. The same force acting on an object with a larger mass, however, will produce a smaller acceleration (fig. 4.5).

Note that the *acceleration* is directly related to the imposed force, not the velocity. Aristotle did not make a clear distinction between acceleration and velocity. Many of us also fail to make the distinction when we think informally about motion. In Newton's theory, this distinction is critical.

Newton's second law is the central quantitative idea of his theory of motion. According to this law, the acceleration of an object is determined by two quantities: the net force acting on the object and the mass of the object. In fact, the concepts of force and mass are, in part, defined by the second law. The net force acting on the object is the cause of its acceleration. Newton's third law, discussed in section 4.4, completes the definition of force by making clear that forces result from interaction of the object with other objects. ▶



**Figure 4.5** The smaller-mass object experiences a larger acceleration than the larger-mass object when identical forces are applied to the two objects.

The **mass** of an object is a quantity that tells us how much resistance an object has to a change in its motion, as indicated by the second law. We call this resistance to a change in motion **inertia**, following Galileo. (See everyday phenomenon box 4.1.) We can define mass as follows:

Mass is a measure of an object's inertia, the property that causes it to resist a change in its motion.

The standard metric unit for mass is the kilogram (kg). We will say more about the determination of mass and its relationship to the weight of an object in section 4.3.

Units of force can also be derived from Newton's second law. If we solve for  $F_{\text{net}}$  by multiplying both sides of the second-law equation by the mass, it can be expressed as

$$F_{\text{net}} = ma$$

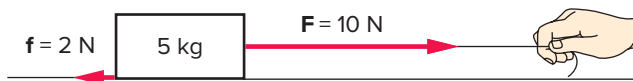
The appropriate unit for force must therefore be the product of a unit of mass and a unit of acceleration, or in the metric system, kilograms times meters per second squared. This frequently used unit is called the **newton (N)**. Accordingly,

$$1 \text{ newton} = 1 \text{ N} = 1 \text{ kg} \cdot \text{m/s}^2$$

### How do forces add?

Our version of the second law implies that the imposed force is the total, or *net, force* acting on the object. Force is a vector quantity whose direction is clearly important. If there is more than one force acting on an object, as there often is, we must then add these forces as vectors, taking into account their directions.

This process is illustrated in figure 4.6 and the sample exercise in example box 4.1. A block is being pulled across a table by a force of 10 N applied through a string attached to the front end of the block. A frictional force of 2 N acts on the block, a result of contact with the table. What is the total force acting on the block?



**Figure 4.6** A block being pulled across a table. Two horizontal forces are involved.

## Example Box 4.1

### Sample Exercise: Finding the Net Force

A block with a mass of 5 kg is being pulled across a tabletop by a force of 10 N applied by a string tied to the front end of the block (fig. 4.6). The table exerts a 2-N frictional force on the block. What is the acceleration of the block?

$$\begin{aligned} F_{\text{string}} &= 10 \text{ N (to the right)} & F_{\text{net}} &= F_{\text{string}} - f_{\text{table}} \\ f_{\text{table}} &= 2 \text{ N (to the left)} & &= 10 \text{ N} - 2 \text{ N} = 8 \text{ N} \\ m &= 5 \text{ kg} & F_{\text{net}} &= 8 \text{ N (to the right)} \\ a &= ? \end{aligned}$$

$$\begin{aligned} a &= \frac{F_{\text{net}}}{m} \\ &= \frac{8 \text{ N}}{5 \text{ kg}} \\ &= 1.6 \text{ m/s}^2 \end{aligned}$$

$$(a = 1.6 \text{ m/s}^2 \text{ to the right})$$

Is the net force the numerical sum of the two forces, 10 N plus 2 N, or 12 N? Looking at the diagram in figure 4.6 should convince you this cannot be true. The two forces oppose each other. Because the forces are in opposite directions, the net force is found by subtracting the frictional force from the force applied by the string, resulting in a net force of 8 N. We cannot ignore the directions of the forces involved.

That forces are vectors whose directions must be taken into account when finding the net force is an important aspect of the second law. For forces restricted to one dimension, as in example box 4.1, finding the net force is not difficult. In problems involving forces in two or three dimensions, addition is more complex but can be accomplished using techniques described in appendix C. In this chapter, we will consider only one-dimensional cases.

A final point about Newton's first and second laws bears repeating: The first law is contained within the second law, but it was very important for Newton to state the first law as a separate law so as to counter long-standing beliefs about motion. The relationship between the two laws can be demonstrated by asking what happens, according to the second law, when the net force acting on an object is zero. In this case, the acceleration  $a = \frac{F_{\text{net}}}{m}$  must also be zero. If the acceleration is zero, the velocity must be constant. The first

## Everyday Phenomenon

## Box 4.1

**The Tablecloth Trick**

**The Situation.** When he was a child, Ricky Mendez saw a magician do the tablecloth trick. A full dinner place setting, including a filled wineglass, sat on a tablecloth covering a small table. The magician, with appropriate fanfare, pulled the tablecloth from the table without disturbing the dinnerware. Ricky ended up in the doghouse, however, when he tried this at home, with disastrous results.

More recently, Ricky saw his physics instructor do a similar trick with a simpler place setting. The students were told that the demonstration had something to do with inertia. Why does the trick work, and how is inertia involved? Why did the trick not work when Ricky tried it at home as a child?

**The Analysis.** The magician's trick, which is frequently used as a physics demonstration, is indeed an illustration of the effects of inertia. Because the nature of frictional forces also plays a role, the choice of a smooth material for the tablecloth is important. (Butcher paper is sometimes substituted in physics demonstrations.) Some practice is usually essential to the successful execution of the trick.

The performer, be it a magician, an instructor, or a student, must pull the cloth or paper very quickly, giving it a large initial acceleration. Pulling slightly downward across the edge of the table helps to assure that there is no upward component to the acceleration and that the acceleration is reasonably uniform across the width of the tablecloth. As the tablecloth accelerates, it exerts a frictional force on the tableware. If we pulled slowly, this frictional force would pull the dishes and glasses along with the tablecloth.

Inertia is the tendency of an object (related to its mass) to resist a change in its motion. When an object is at rest, it remains at rest unless a force is applied. There *is* a force acting on the plates and glasses, however—the frictional force exerted by the tablecloth. If the tablecloth is pulled quickly enough, the frictional force is in effect for only a very short time, so the acceleration of the objects is very brief. The objects will accelerate slightly, but not nearly as much as the tablecloth.

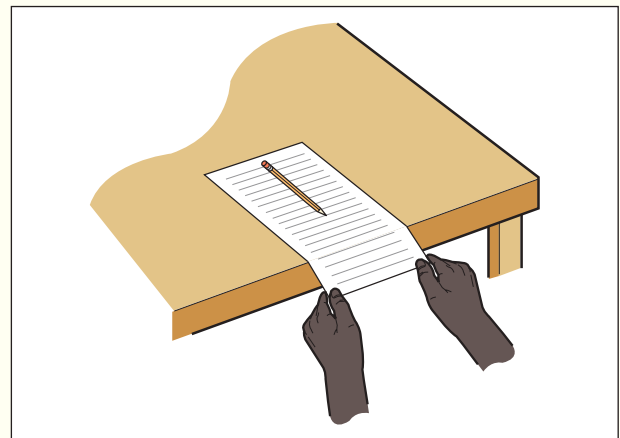
Two aspects of the frictional force are important to our understanding of what happens. One is that the force of static friction (in effect when the surfaces are not sliding relative to each other) has a maximum value that is determined by the nature of the contacting surfaces and by the force pushing the surfaces together. The second is that once the objects start to slide, kinetic, or sliding, friction comes into play. The force of kinetic friction is usually smaller than that of static friction.

When the tablecloth is given a large lateral acceleration, the force needed to also accelerate the tableware ( $F_{\text{net}} = ma$ ) exceeds the maximum force of static friction between the dish or

glass and the tablecloth. The tablecloth then begins to slide underneath the dish, reducing the size of the frictional force. If the surfaces are smooth, the frictional force is never large enough to produce an acceleration of the dish or glass that is anywhere near the size of the acceleration of the tablecloth. In the fraction of a second that this force acts, it does not have a chance to increase the velocity very much or to move the object very far. (See synthesis problem SP3.) Once the tablecloth is no longer in contact with the object, the frictional force exerted by the table quickly decelerates the object.

You can test these ideas yourself with a pencil, cup, or similar object (preferably nonbreakable) and a sheet of smooth tablet paper. Place the paper on a smooth desk or table surface with the end of the paper extending over the edge. Grasping the paper with both hands near the corners, as shown in the drawing, pull it downward across the edge of the desk or table. Notice that a slow pull brings the object along with the paper, but a very rapid pull leaves the object essentially in place. (The objects will usually move slightly in the direction of the pull.)

Before you graduate to tablecloths and full dinner place settings, a few cautions are in order. Objects that can tip, like filled wineglasses, are more difficult to work with. The bottom may start to move while the top portion (with its greater inertia) remains in place, causing the glass to tip and spill the wine or water. Also, the larger the tablecloth, the more difficult it is to pull it clear of the table—your hands must move very rapidly through a large distance in the pull. Practice is essential, which is the case for most of the tricks that magicians (and physics instructors) perform.



Grasp the paper near the corners and pull slightly downward across the edge of the table. A quick pull will leave the pencil near its initial position.

law tells us that if the net force is zero, the object moves with constant velocity (or remains at rest). Newton's first law addresses the special case of the second law in which the net force acting on an object is zero.

The central principle in Newton's theory of motion is his second law of motion. This law states that the acceleration of an object is proportional to the net force applied to the object and inversely proportional to the mass of the object. The mass of an object is its inertia, or resistance to change in motion. Newton's first law is a restatement of Galileo's principle of inertia, which defines what happens when the net force acting on the object is zero. To find the net force acting on the object, we take into account the directions of the individual forces and add them as vectors.

### 4.3 Mass and Weight

What exactly is weight? Is your *weight* the same as your *mass*, or is there a difference in the meaning of these two terms? Clearly, mass plays an important role in Newton's second law. *Weight* is a familiar term often used interchangeably with *mass* in everyday language. Here again, physicists are very specific with the words they use. There is a distinction between mass and weight that is important to Newton's theory.

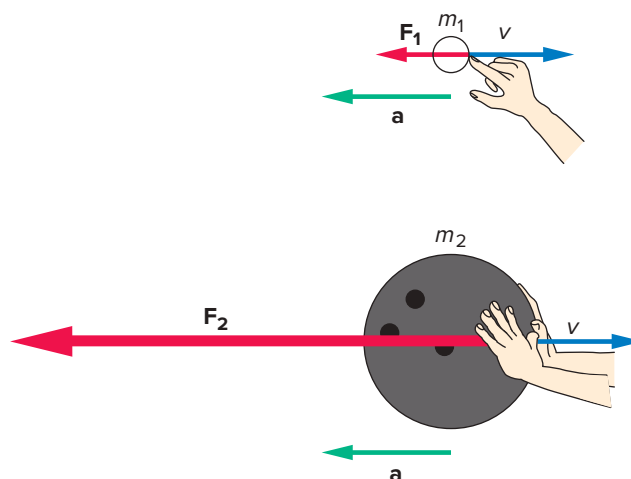
#### How can masses be compared?

From the role that mass plays in Newton's second law, we can devise experimental methods of comparing masses. Mass is defined as the property of matter that determines how much an object resists a change in its motion. The greater the mass, the greater the *inertia*, or resistance to change, and the smaller the acceleration provided by a given force. Imagine, for example, trying to stop (decelerate) a bowling ball and a Ping-Pong ball that are moving initially with equal velocities (fig. 4.7). A much greater force is required to stop the bowling ball than to stop the Ping-Pong ball because of the difference in mass. According to the second law, the force required is proportional to the mass.

In effect, we are using Newton's second law to define mass. If we used the same force to accelerate different masses, the different accelerations could be used to compare the masses involved. If we choose one mass as a standard, any other mass can be measured against the standard mass by comparing the accelerations produced by equal forces. We could, in principle, determine the mass of any object this way.

#### How do we define weight?

In practice, the method just described is not convenient for comparing masses because of the difficulty of measuring

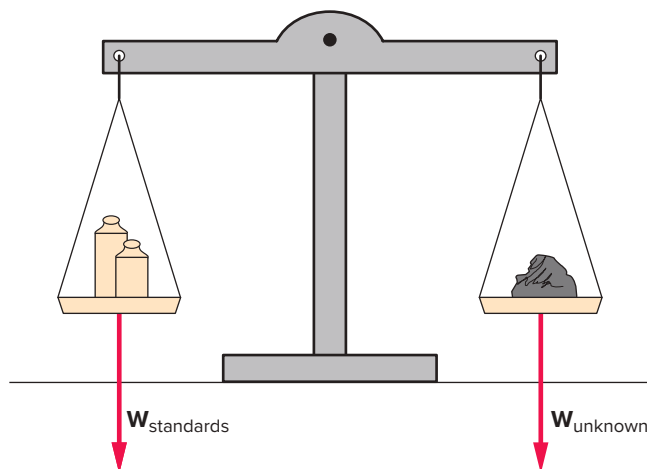


**Figure 4.7** Stopping a bowling ball and a Ping-Pong ball. A much larger force is required to produce the same *rate* of change in velocity for the larger mass.

acceleration. The more common method of comparing masses is to “weigh” the objects on a balance or scale (fig. 4.8). What we actually do in weighing is to compare the gravitational force acting on the mass we wish to measure with that acting on some standard mass. The gravitational force acting on an object is the **weight** of the object. As a force, weight has different units (newtons) than mass (kilograms).

How is weight related to mass? From our discussion of gravitational acceleration in chapter 3, we know that objects of different mass experience the same gravitational acceleration near the Earth's surface ( $g = 9.8 \text{ m/s}^2$ ). This acceleration is caused by the gravitational force exerted by the Earth on the object, which is the weight of the object. According to Newton's second law, the force (the weight) is equal to the mass times the acceleration, or

$$W = mg$$



**Figure 4.8** Comparing an unknown mass to standard masses on a balance.

## Example Box 4.2

### Sample Exercise: Computing Weights

Suppose that a woman has a mass of 50 kg. What is her weight in

- newtons?
- pounds?

a.  $m = 50 \text{ kg}$                        $W = mg$   
 $W = ?$                                        $= (50 \text{ kg})(9.8 \text{ m/s}^2)$   
     $= \mathbf{490 \text{ N}}$

b.  $W = ?$  in pounds  
 $1 \text{ lb} = 4.45 \text{ N}$                        $W = \frac{490 \text{ N}}{4.45 \text{ N/lb}}$   
     $= \mathbf{110 \text{ lb}}$

The symbol **W** represents the weight. It is a vector whose direction is straight down toward the center of the Earth.

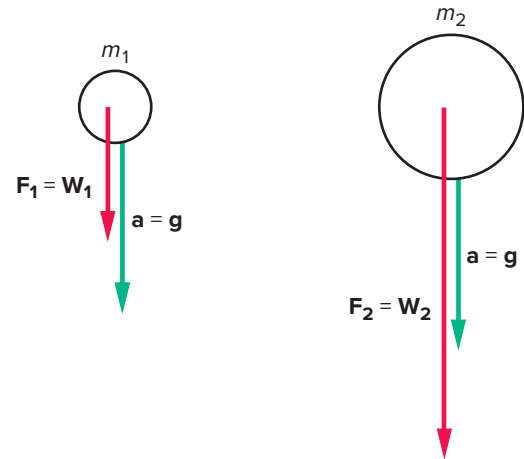
If we know the mass of an object, we can then compute its weight. An example is provided in example box 4.2, in which a woman with a mass of 50 kg has a weight of 490 N. Since we are more used to expressing weights in the English system, we also convert her weight in newtons to pounds (lb), which yields a weight of 110 lb. The pound is most commonly used as a unit of *force*, not mass, in the English system. A mass of 1 kg weighs approximately 2.2 lb near the Earth's surface.

Although weight is proportional to mass, it also depends on the gravitational acceleration  $g$ . Because  $g$  varies slightly from place to place on the surface of the Earth—and has a much smaller value on the moon or the smaller planets—the weight of an object clearly depends on where that object is. On the other hand, the mass of an object is a property of the object related to the quantity of matter making up that object and does not depend on the location of the object.

The gravitational acceleration on the moon is approximately one-sixth that on the Earth's surface. If we transported the woman whose weight we have just determined to the moon, her weight would decrease to about 18 lb (or 82 N), one-sixth her weight on Earth. The woman's mass would still be 50 kg, provided that the trip did not take too much out of her. The mass of an object changes only if we add or subtract matter from it.

### Why is the gravitational acceleration independent of mass?

The distinction between weight and mass can provide insight into why the gravitational acceleration is independent of mass. Let's turn to the case of a falling object and consider its motion using Newton's second law. Reversing the argument that we used in defining weight, we use the



**Figure 4.9** Different gravitational forces (weights) act on falling objects of different masses, but because acceleration is inversely proportional to mass, the objects have the same acceleration.

gravitational force (the weight) to determine the acceleration. By Newton's second law, the acceleration can be found by dividing the force ( $\mathbf{W} = m\mathbf{g}$ ) by the mass:

$$\mathbf{a} = \frac{m\mathbf{g}}{m} = \mathbf{g}$$

Mass cancels out of the equation when we compute the acceleration for a falling object. The gravitational force is proportional to the mass, but by Newton's second law, the acceleration is inversely proportional to the mass: These two effects cancel each other. This holds true only for falling objects. In most other cases, the net force does not depend directly on the mass.

Force and acceleration are *not* the same, although they are closely related by Newton's second law. A heavy object experiences a larger gravitational force (its weight) than a lighter object, but the two objects will have the same gravitational acceleration (fig. 4.9). Because the gravitational force is proportional to mass, we find the same acceleration for different masses. The gravitational force will be discussed further in chapter 5 when we take up Newton's law of gravitation, a critical piece of his overall theory of motion.

Weight and mass are not the same. Weight is the gravitational force acting on an object, and mass is an inherent property related to the amount of matter in the object. Near the Earth's surface, weight is equal to the mass multiplied by the gravitational acceleration ( $\mathbf{W} = m\mathbf{g}$ ), but the weight would change if we took the object to another planet where  $\mathbf{g}$  had a different value. The reason that all objects experience the same gravitational acceleration near the Earth's surface is that the gravitational force is proportional to the mass of the object, but acceleration is equal to the force divided by the mass.



## 4.4 Newton's Third Law

Where do forces come from? If you push on a chair to move it across the floor, does the chair also push back on you? If so, how does that push affect your own motion? Questions like these are important to what we mean by *force*. Newton's third law provides some answers.

**Newton's third law of motion** is an important part of his definition of force. It is an essential tool for analyzing the motion or lack of motion of real objects, but it is often misunderstood. For this reason, it is good to take a careful look at the statement and use of the third law.

### How does the third law help us to define force?

If you push with your hand against a large chair or any other large object, such as the wall of your room, you will feel the object push back against your hand. A force is acting on your hand that you can sense as it compresses your hand. Your hand is interacting with the chair or wall, and that object pushes back against your hand as you push against the object.

Newton's third law contains the idea that forces are caused by such interactions of two objects, each exerting a force on the other. It can be stated thus:

If object A exerts a force on object B, object B exerts a force on object A that is equal in magnitude but opposite in direction to the force exerted on B.

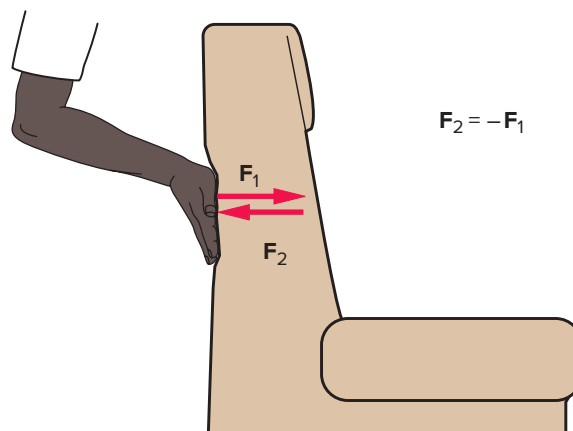
The third law is sometimes referred to as the **action/reaction principle**—for every action there is an equal but opposite reaction. Note that the two forces always act on two *different* objects, never on the same object. Newton's definition of force includes the idea of an *interaction* between objects. The forces represent that interaction.

If you exert a force  $\mathbf{F}_1$  on the chair with your hand, the chair pushes back on your hand with a force  $\mathbf{F}_2$  that is equal in size but opposite in direction (fig. 4.10). Using this notation, Newton's third law can be stated in symbolic form as

$$\mathbf{F}_2 = -\mathbf{F}_1$$

The minus sign indicates that the two forces have opposite directions. The force  $\mathbf{F}_2$  acts on your hand and partly determines your own motion, but it has nothing to do with the motion of the chair. Of this pair of forces, the only one that affects the motion of the chair is the one acting on the chair,  $\mathbf{F}_1$ .

Our definition of force is now complete. Newton's second law tells us how the motion of an object is affected by a force, and his third law tells where forces come from. They come from interactions with other objects. With a suitable definition of mass, which also depends on the second law, we know



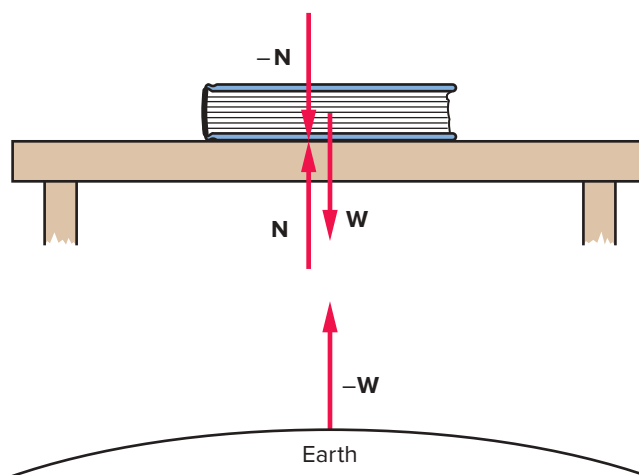
**Figure 4.10** The chair pushes back on the hand with a force  $\mathbf{F}_2$  that is equal in size but opposite in direction to the force  $\mathbf{F}_1$  exerted by the hand on the chair.

how to measure the size of forces by determining the acceleration that they produce ( $\mathbf{F} = m\mathbf{a}$ ). Both the second and third laws are necessary to define what we mean by *force*.

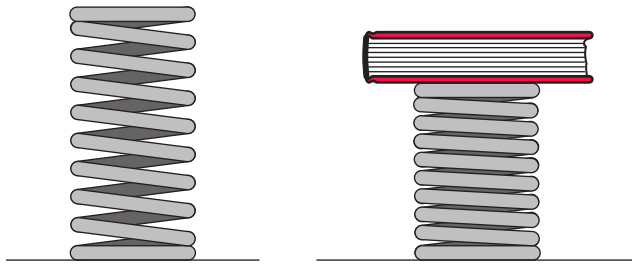
### How can we use the third law to identify forces?

How do we identify the forces that act on an object to analyze how that object will move? First, we identify other objects that interact with the object of interest. Consider a book lying on a table (fig. 4.11). What objects are interacting with the book? Because it is in direct contact with the table, the book must be interacting with the table, but it also interacts with the Earth through the gravitational attraction.

The downward pull of gravity that the Earth exerts on the book is the book's weight  $\mathbf{W}$ . The object interacting with the book to produce this force is the Earth itself. The book and the Earth are attracted to each other (through gravity) with equal and opposite forces that form a third-law pair. The Earth pulls down on the book with the force  $\mathbf{W}$ , and the



**Figure 4.11** Two forces,  $\mathbf{N}$  and  $\mathbf{W}$ , act on a book resting on a table. The third-law reaction forces  $-\mathbf{N}$  and  $-\mathbf{W}$  act on different objects: the table and the Earth.



**Figure 4.12** An uncompressed spring and the same spring supporting a book. The compressed spring exerts an upward force on the book.

book pulls upward on the Earth with the force  $-\mathbf{W}$ . Because of the Earth's enormous mass, the effect of this upward force on the Earth is extremely small.

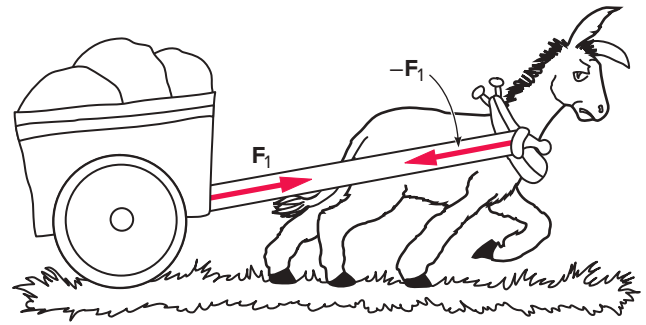
The second force acting on the book is an upward force exerted on the book by the table. This force is often called the **normal force**, where the word *normal* means “perpendicular” rather than “ordinary” or “usual.” The normal force  $\mathbf{N}$  is always perpendicular to the surfaces of contact. The book, in turn, exerts an equal but oppositely directed downward force  $-\mathbf{N}$  on the table. These two forces,  $\mathbf{N}$  and  $-\mathbf{N}$ , constitute another third-law pair. They result from the mutual compression of the book and table as they come into contact with each other. You could think of the table as a large and very stiff spring that compresses ever so slightly when the book is placed on it (fig. 4.12).

The two forces acting on the book, the force of gravity and the force exerted by the table, also happen to be equal in size and opposite to each other, but this is *not* due to the third law. How do we know that they must be equal? Because the book's velocity is not changing, its acceleration must be zero. According to Newton's *second* law, the net force  $\mathbf{F}_{\text{net}}$  acting on the book must then be zero, because  $\mathbf{F}_{\text{net}} = m\mathbf{a}$  and the acceleration  $\mathbf{a}$  is zero. The only way that the net force can be zero is for the two contributing forces,  $\mathbf{W}$  and  $\mathbf{N}$ , to cancel each other. They must be equal in magnitude and opposite in direction for their sum to be zero.

Even though equal in size and opposite in direction, these two forces do not constitute a third-law action/reaction pair. ▶ They both act on the *same* object, the book, and the third law always deals with interactions between *different* objects. Thus,  $\mathbf{W}$  and  $\mathbf{N}$  are equal in size and opposite in direction in this case as a consequence of the second law rather than the third law. If they did not cancel each other, the book would accelerate away from the tabletop. (Both the second and third laws are critical to the analysis of the elevator example in everyday phenomenon box 4.2.)

### Can a mule accelerate a cart?

Consider the story of a stubborn mule, which, having had a brief exposure to physics, argued to his handler that there was no point in pulling on the cart to which he was connected. According to Newton's third law, the mule argued,



**Figure 4.13** A mule and a cart. Does Newton's third law prevent the mule from moving the cart? There are additional forces not shown here (see the text).

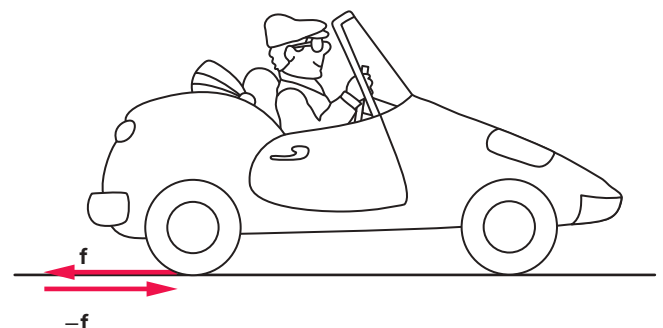
the harder he pulls on the cart, the harder the cart pulls back on him (fig. 4.13). The net result is, therefore, nothing. Is he right, or is there a fallacy in his argument?

The fallacy is simple but perhaps not obvious. The motion of the cart is affected by only one of the two forces that the mule is talking about—namely, the force that acts *on the cart*. The other force in this third-law pair acts on the mule and must be considered in conjunction with other forces that act on the mule to determine how he will move. The cart will accelerate if the force exerted by the mule *on the cart* is larger than the frictional forces acting *on the cart*. Try placing yourself in the role of the handler and explain the fallacy to the mule.

### What force causes a car to accelerate?

As with the mule, the **reaction force** to a push or pull exerted by an object is often extremely important in describing the motion of the object itself. Consider the acceleration of a car. The engine cannot push the car because it is part of the car. The engine drives either the rear or front axle of the car, which causes the tires to rotate. The tires in turn push against the road surface through the force of friction  $\mathbf{f}$  between the tires and the road (fig. 4.14).

According to Newton's third law, the road must then push against the tires with an equal but oppositely directed force  $-\mathbf{f}$ . This external force causes the car to accelerate.



**Figure 4.14** The car pushes against the road; in turn, the road pushes against the car.

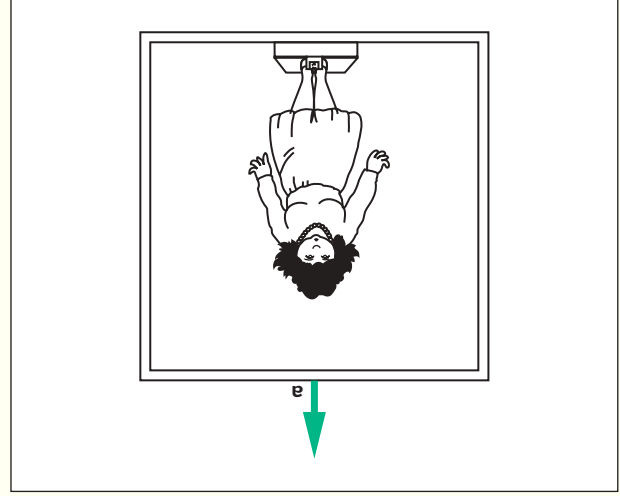
## Everyday Phenomenon

### Box 4.2

#### Riding an Elevator

**The Situation.** We have all had the experience of riding an elevator and feeling sensations of heaviness or lightness as the elevator accelerates up or down. The feeling of lightness as the elevator accelerates downward is generally more striking, particularly if the acceleration is not smooth.

Do we really weigh more or less than usual in these situations? If you took a bathroom scale into the elevator, would it read your true weight when the elevator is accelerating? How can we apply Newton's laws of motion to explore these questions?



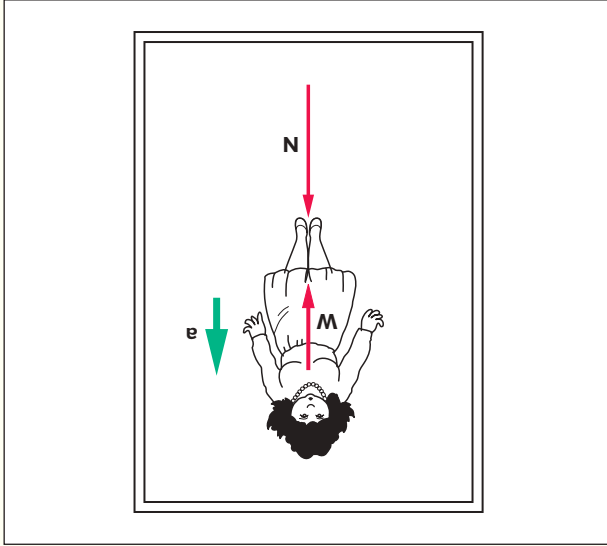
A woman standing on a bathroom scale inside an accelerating elevator. Will she read her true weight on the scale?

**The Analysis.** The first step in analyzing any situation using Newton's laws is to isolate the body of interest and carefully identify the forces that act on just that body. Different choices are possible for which objects to isolate, but some choices will be more productive than others. In this case, it makes sense to isolate the person standing on the scale, because her weight is the focus of our questions. The second drawing shows a **free-body diagram** of the woman indicating just those forces that act on her.

In this case, just two other objects interact with the woman, resulting in two forces. The Earth pulls downward on the woman through the force of gravity **W**. The scale pushes upward on her with a force **N**, the normal force. The vector sum of these two forces determines her acceleration. If the elevator is accelerating upward with an acceleration **a**, the woman must also be accelerating upward at that rate. The net force must also be upward, which implies that the normal force **N** is larger than the gravitational force **W**. Using signs to indicate direction, and letting the positive direction be upward, Newton's second law requires that

$$F_{\text{net}} = N - W = ma$$

A free-body diagram of the woman in the elevator when accelerating upward. Why is the normal force **N** larger than the weight **W**?



What about the scale reading? According to Newton's third law, the woman exerts a downward force on the scale equal in size to the normal force **N**, but opposite in direction. Because this is the force pushing down on the scale, the scale should read the value **N**, the magnitude of the normal force. The woman's true weight has not changed, but her apparent weight as measured by the scale has increased by an amount equal to **ma**. (Rearranging the second-law equation yields  $N = W + ma$ .)

What happens when the elevator is accelerating downward? In that case, the net force acting upon the woman must be downward, and the normal force must be less than her weight. The scale reading **N** will then be less than the woman's true weight by the amount **ma**, perhaps producing a smile rather than a scowl. If the elevator cable breaks, we have a particularly interesting special case. Both the woman and the elevator will accelerate downward with the gravitational acceleration **g**. Because the woman's weight is all that is required to give her that acceleration, the normal force acting on her feet must then be zero. The scale reading will likewise be zero, and the woman is apparently weightless!

The sensation of our own weight is produced in part by the pressure on our feet and forces in our leg muscles needed to maintain our posture. The woman will feel weightless in this situation even though her true weight (the gravitational force acting on her) has not changed. In fact, she will be able to float around in the elevator just as astronauts do in the orbiting space station. (The space station is also falling toward the Earth as it moves laterally in its orbit.) This happy scenario will come to a crashing halt for the woman, however, when the elevator reaches the bottom of the shaft.

Obviously, friction is desirable in this case. Without friction, the tires would spin, and the car would go nowhere. The case of the mule is similar. The frictional force exerted by the ground on his hooves causes him to accelerate forward. This frictional force is the reaction to his pushing against the ground.

Think about this next time you find yourself walking. What external force causes you to accelerate as you start out? What is your role, and that of friction, in producing this force? How would you walk on an icy or slippery surface?

To figure out what forces are acting on any object, we need first to identify the other objects with which it is interacting. Some of these will be obvious. Any object in direct contact with the object of interest will presumably contribute a force. Interactions producing other forces, such as air resistance or gravity, may be less obvious but still recognizable with a little thought. The third law is the principle we use to identify any of these forces.

Newton's third law of motion completes his definition of force. The third law notes that forces arise from interactions between different objects. If object A exerts a force on object B, object B exerts an equal-size but oppositely directed force on A. In order to apply the second law of motion, we use the third law to identify the external forces that act on an object.

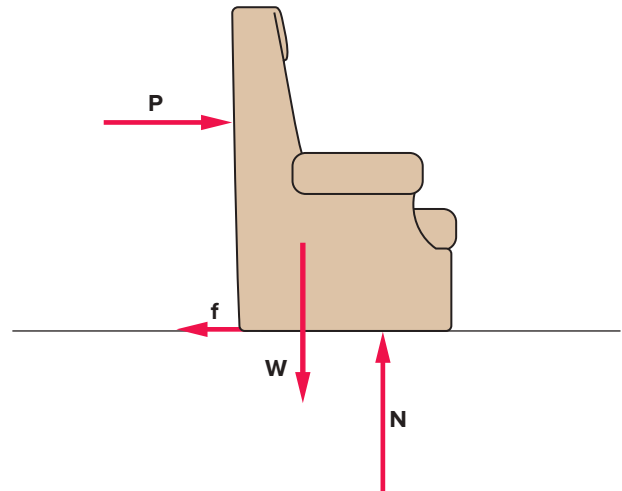
## 4.5 Applications of Newton's Laws

We have now discussed Newton's laws of motion and the definitions of force and mass within these laws. To appreciate their usefulness, however, we must be able to apply them to some familiar examples, such as pushing a chair or throwing a ball. How do Newton's laws help us make sense of these motions? Do they provide a satisfactory picture of what is going on?

### What forces are involved in moving a chair?

We have returned from time to time to the example of a chair being pushed but have not yet analyzed how and why it moves. As indicated in section 4.4, the first step in any analysis is to identify the forces that act on the chair. As shown in figure 4.15, four forces act on the chair from four separate interactions:\*

1. The force of gravity (the weight)  $\mathbf{W}$  due to interaction with the Earth.
2. The upward (normal) force  $\mathbf{N}$  exerted by the floor due to compression of the floor.



**Figure 4.15** Four forces act on a chair being pushed across the floor: the weight  $\mathbf{W}$ , the normal force  $\mathbf{N}$ , the force  $\mathbf{P}$  exerted by the person pushing, and the frictional force  $\mathbf{f}$ .

3. The force exerted by the hand of the person pushing,  $\mathbf{P}$ .
4. The frictional force  $\mathbf{f}$  exerted by the floor.

Two of these forces, the normal force  $\mathbf{N}$  and the frictional force  $\mathbf{f}$ , are actually due to interactions with a single object, the floor. Because they are due to different effects and are perpendicular to one another, they are usually treated separately.

The effects of the two vertical forces acting on the chair, the weight  $\mathbf{W}$  and the normal force  $\mathbf{N}$ , cancel each other. Like the book on the table in section 4.4, this results because there is no acceleration of the chair in the vertical direction. According to Newton's second law, the sum of the vertical forces must then be zero, which implies that the weight  $\mathbf{W}$  and the normal force  $\mathbf{N}$  are equal in size but opposite in direction. (But they do not constitute a third-law pair.) They play no direct role in the horizontal motion of the chair.

The other two forces, the push of the hand  $\mathbf{P}$  and the frictional force  $\mathbf{f}$ , do not necessarily cancel. These two forces together determine the horizontal acceleration of the chair. The push  $\mathbf{P}$  must be larger than the frictional force  $\mathbf{f}$  for the chair to accelerate. In the most likely scenario for moving the chair, you first give a push with your hand that is larger than the frictional force. This produces a total force, with magnitude  $P - f$ , in the forward direction, causing the chair to accelerate.

Once you have accelerated the chair to a reasonable velocity, you reduce the strength of your push  $\mathbf{P}$ , so that it is equal in size to the frictional force. The net horizontal force becomes equal to zero, and the horizontal acceleration is also zero by Newton's second law. If you sustain the push at this level, the chair moves across the floor with constant velocity.

Finally, you remove your hand and its push  $\mathbf{P}$ , and the chair quickly decelerates to zero velocity under the influence of the frictional force  $\mathbf{f}$ . If you happen to have a chair and a smooth floor handy, try to produce this motion. See if you can feel differences in the force you are exerting with your

\*A figure such as figure 4.15, showing all the forces acting on an object, is often called a free-body diagram. See also everyday phenomenon box 4.2.

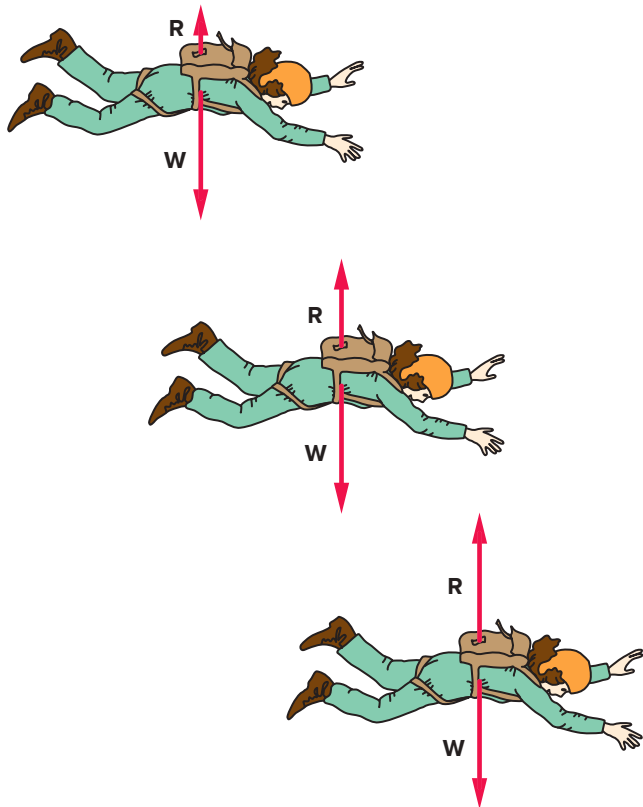
hand at various points in the motion. The force should be largest at the beginning of the motion.

The size of the force needed to keep the chair moving with constant velocity is determined by the strength of the frictional force, which, in turn, is influenced by the weight of the chair and the condition of the floor surface. If you fail to recognize the importance of the frictional force, you may be led, like Aristotle, to think that a force is always needed to keep an object moving. Frictional forces are almost always present, but they are not as obvious as the forces applied directly.

### Does a skydiver continue to accelerate?

In chapter 3, we considered the fact that an object falls with constant acceleration  $g$  if air resistance is not a significant factor. What about objects such as skydivers who fall for large distances? Do they continue to accelerate at this rate, gaining larger and larger downward velocities? Any person with experience in skydiving knows that this does not happen. Why not?

If air resistance were not a factor, a falling object would experience only the gravitational force (its weight) and would indeed continue to accelerate. In skydiving, air resistance is an important factor, and its effects get larger as the velocity of the skydiver (or any object) increases. The skydiver has an initial acceleration of  $g$ , but as her velocity increases, the force of air resistance becomes significant. Her acceleration decreases (fig. 4.16).



**Figure 4.16** The force of air resistance  $R$  acting on a skydiver increases as the velocity increases.

## Example Box 4.3

### Sample Exercise: Air Resistance

As an 8-kg rock is falling from a high cliff, it experiences air resistance, which increases as the velocity of the rock increases. At a particular instant in time, assume the rock experiences an *upward* force due to air resistance of 30 N.

- What is the gravitational force on the rock? What is the direction of this force?
- What is the net force on the rock? What is the direction of this force?
- What are the magnitude and direction of the acceleration on the rock at this instant in time?

$$\begin{aligned} \text{a. } m &= 8 \text{ kg} & W &= mg = (8 \text{ kg})(9.8 \text{ m/s}^2) \\ & & g &= 9.8 \text{ m/s}^2 & \mathbf{W} &= \mathbf{78.4 \text{ N, downward}} \end{aligned}$$

- There are two forces on the rock; the upward force of air resistance and the downward gravitational force. The net force is the difference between the two. Since the gravitational force is greater the net force will be downward. We will assume upward is positive.

$$\begin{aligned} \mathbf{F}_{\text{air}} &= 30 \text{ N, upward} & F_{\text{net}} &= F_{\text{air}} - W \\ \mathbf{W} &= \mathbf{78.4 \text{ N, downward}} & &= 30 \text{ N} - 78.4 \text{ N} \\ & & &= -48.4 \text{ N} \\ & & \mathbf{F}_{\text{net}} &= \mathbf{48.4 \text{ N, downward}} \end{aligned}$$

$$\begin{aligned} \text{c. } m &= 8 \text{ kg} & F_{\text{net}} &= ma \\ F_{\text{net}} &= -48.4 \text{ N} & a &= F_{\text{net}}/m \\ & & a &= -48.4 \text{ N}/8 \text{ kg} \\ & & a &= -6.05 \text{ m/s}^2 \\ & & \mathbf{a} &= \mathbf{6.05 \text{ m/s}^2, \text{downward}} \end{aligned}$$

For small velocities, the air-resistive force  $R$  is small, and the weight is the dominant force. As the velocity increases, the air-resistive force gets larger, causing the total magnitude of the downward force,  $W - R$ , to decrease. Because the net force is responsible for the acceleration, the acceleration will also decrease. A sample calculation is shown in example box 4.3. Ultimately, as the velocity continues to increase, the air-resistive force reaches a value equal in size to the gravitational force. The net force is then zero, and the skydiver stops accelerating. We say that she has reached **terminal velocity**, and from there on, she moves downward with constant velocity. This terminal velocity is usually between 100 and 120 MPH.

Frictional or resistive forces play a critical role in analyzing the motion. Aristotle did not have the opportunity to try skydiving (nor have many of us), so this example was not a part of his experience. He did observe the terminal velocity, however, of very light objects, such as feathers or leaves. The weight of such objects is small and the surface area is

large relative to the weight, so the air-resistive force  $\mathbf{R}$  becomes equal in size to the weight much sooner than for a heavier object.

Try tearing a small corner from a piece of paper and watching it fall. Does it appear to reach a constant (terminal) velocity? It will flutter as it falls, but it does not seem to accelerate much for most of its downward motion. You can see why Aristotle concluded that heavier objects fall faster than lighter objects. Dropping heavier objects through water can also show the terminal velocity. Water exerts a larger resistive force at lower velocities than air.

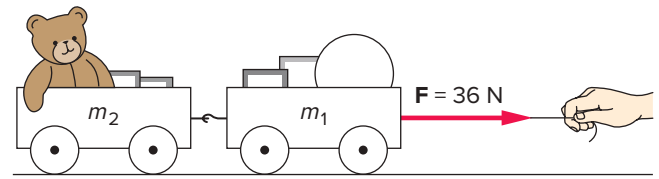
### What happens when a ball is thrown?

Aristotle had trouble explaining the motion of a thrown object, such as a ball, once it had left the thrower's hand. Let's reconsider this example from a Newtonian perspective. Do we need a force to keep the ball moving? Not according to Newton's first law. Three forces, however, are involved in the flight of the ball: the initial push by the thrower, the downward pull of gravity, and (once again) air resistance (fig. 4.17).

To highlight Newton's approach, it is best to break down the motion into two different spans of time. The first is the process of throwing, when the hand is in contact with the ball. During this interval, the force  $\mathbf{P}$  exerted by the hand dominates the motion. The combined effects of the other forces (gravity and air resistance) must be smaller than the force  $\mathbf{P}$  if the ball is to accelerate. Thus,  $\mathbf{P}$  accelerates the ball to a velocity that we often refer to as the *initial* velocity. The magnitude and direction of the initial velocity are determined by the strength and direction of the force  $\mathbf{P}$  and the length of time it acts on the ball. Because this force usually varies with time, a full analysis of the process of throwing gets quite complex.

Once the ball leaves the hand, however, we are in the second time period, where  $\mathbf{P}$  is no longer a consideration. During this interval, the gravitational force  $\mathbf{W}$  and the air-resistive force  $\mathbf{R}$  produce changes in the ball's velocity. From this point on, the problem becomes one of projectile motion (see section 3.4). The gravitational force accelerates the ball downward, and the air-resistive force acts in a direction opposite to the velocity, gradually reducing the ball's velocity.

Contrary to Aristotle's view, no forces are needed to keep the ball moving once it has been thrown. In fact, if an object were thrown in deep space, where air resistance is nonexistent



**Figure 4.18** Two connected carts being accelerated by a force  $\mathbf{F}$  applied by a string.

and gravitational forces are very weak, it would keep moving with constant velocity, as stated in Newton's first law.

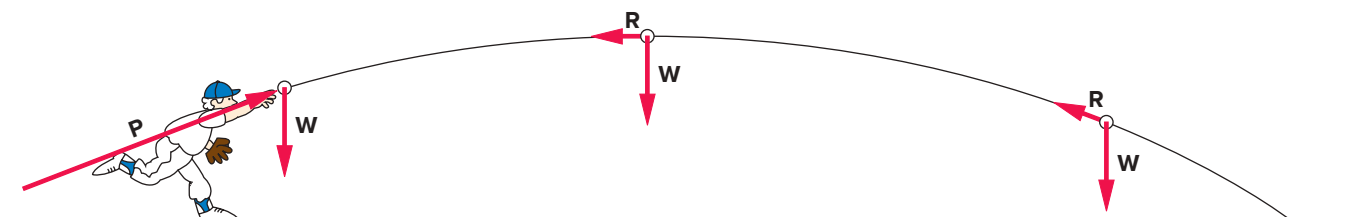
Because the air-resistive force or the push exerted by a person throwing a ball varies with time, we have avoided working out numerical examples for these situations. Just identifying the forces involved and their causes due to third-law interactions with other objects provides a useful description of what is happening.

### How do we analyze the motion of connected objects?

Verification of Newton's laws of motion came initially from simpler examples that could be easily set up in the laboratory. One example not difficult to picture and set up in a physics laboratory (or even at home if suitable toys are available) is two connected carts accelerated by the pull of a string (fig. 4.18). To keep things simple, we will assume that the carts have excellent wheel bearings, so that they roll with very little friction. We will also assume that a scale is available to determine the masses of the carts and their contents.

To measure the magnitude of the force applied by the string, we would have to insert a small spring balance somewhere between the hand and the carts. The trickiest part of the entire experiment is applying a steady force with this arrangement while the carts are accelerating.

If we know the masses of the carts and their contents, and the magnitude of the force applied by the string, we should be able to predict the value of the acceleration of the system from Newton's second law. (See example box 4.4.) For the masses given in the example, and an applied force of 36 N, we find an acceleration of  $2.0 \text{ m/s}^2$  for the two carts. The acceleration could be verified experimentally by measuring the time required for the carts to travel a fixed distance and using the equations developed for constant acceleration in chapter 2 to calculate an experimentally determined value.



**Figure 4.17** Three forces act on a thrown ball: the initial push  $\mathbf{P}$ , the weight  $\mathbf{W}$ , and air resistance  $\mathbf{R}$ .

## Example Box 4.4

### Sample Exercise: Connected Objects

Two connected carts are pulled across the floor under the influence of a force of 36 N applied by a string (fig. 4.18). The forward cart and its contents have a mass of 10 kg, and the second cart and contents have a mass of 8 kg. Assuming that frictional forces are negligible,

- What is the acceleration of the two carts?
- What is the net force acting on each cart?

- a. Defining the system as both carts, as discussed in the text,

$$m_1 = 10 \text{ kg} \quad F_{\text{net}} = ma$$

$$m_2 = 8 \text{ kg}$$

$$F = 36 \text{ N} \quad \text{or: } a = \frac{F_{\text{net}}}{m} = \frac{36 \text{ N}}{10 \text{ kg} + 8 \text{ kg}}$$

$$a = ? = \frac{36 \text{ N}}{18 \text{ kg}} = 2.0 \text{ m/s}^2$$

$$a = 2.0 \text{ m/s}^2 \text{ in the forward direction}$$

- b. Treating each cart separately:

$$F_{\text{net}} = ? \quad \text{first cart}$$

$$(\text{for each cart}) \quad F_{\text{net}} = ma$$

$$= (10 \text{ kg})(2 \text{ m/s}^2)$$

$$= 20 \text{ N}$$

$$F_{\text{net}} = 20 \text{ N in the forward direction}$$

$$\text{second cart}$$

$$F_{\text{net}} = ma$$

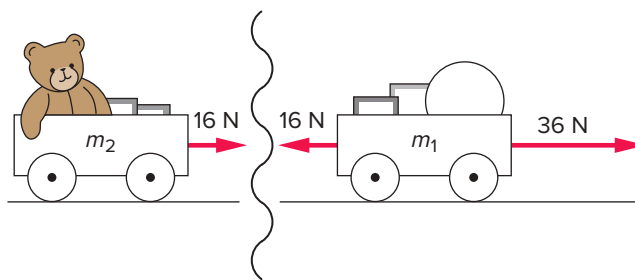
$$= (8 \text{ kg})(2 \text{ m/s}^2)$$

$$= 16 \text{ N}$$

$$F_{\text{net}} = 16 \text{ N in the forward direction}$$

In example box 4.4, we first treat the two carts as a single system to find the acceleration. Suppose, however, that we want to know the magnitude of the force exerted by the hooks connecting the two carts. In this case, it makes sense to treat the motion of the individual carts separately. Once we know the acceleration, we again apply Newton's second law to find the net force acting on each cart. This computation is done in the second part of example box 4.4 and is illustrated in figure 4.19.

For the second cart, a force of 16 N is required to produce the acceleration of 2 m/s<sup>2</sup>. By Newton's third law, there should then be a force of 16 N pulling back on the first cart.



**Figure 4.19** The interaction between the two carts illustrates Newton's third law.

Combined with the forward force of 36 N applied by the string, this results in a net force of 20 N acting on the first cart (36 N – 16 N). This is exactly the value required to give the first cart an acceleration of 2 m/s<sup>2</sup>.

From this example, we see that Newton's laws provide a completely consistent picture of the forces and accelerations of the different parts of the connected-cart system. This is a necessary condition for us to accept the laws as valid. Obviously, another condition is that any predictions be confirmed by experimental measurements. This has been done many times by experiments similar to the one we have dealt with here.

We could try many variations on this experiment in the laboratory to see if the results agree with predictions derived from Newton's laws. Even with careful experimental technique using accurate stopwatches and balances, however, our results are unlikely to agree exactly with our predictions. It is impossible to eliminate the effects of friction completely, and none of our measurements can be made with infinite precision. The art of the experimentalist is to reduce these inaccuracies to a minimum, as well as to predict how they affect our results.

Newton's laws of motion provide both qualitative and quantitative explanations of any familiar motion. First, we identify the forces acting on the object by examining interactions with other objects. The relative sizes of these forces, when added together, give the acceleration of the object. The acceleration may change as the forces change with time, as in the case of a skydiver. Newton's laws have been verified many times by experimental tests of their quantitative predictions. They are a much more consistent theory of the causes of motion than the older Aristotelian view.

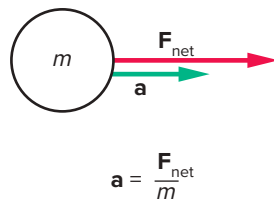
## Summary

In 1685, Newton published his *Principia*, in which he introduced three laws of motion as the foundation of his theory of mechanics. These laws continue to serve as an extremely useful model for explaining the causes of motion and for predicting how objects will move in many familiar situations.

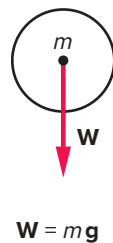
**1 A brief history.** Newton's theory was constructed on groundwork laid by Galileo and replaced a much earlier and less quantitative model developed by Aristotle to explain motion. Newton's theory had much greater predictive power than

Aristotle's ideas. Although we now recognize its limitations, Newton's theory is still used extensively to explain the motion of ordinary objects.

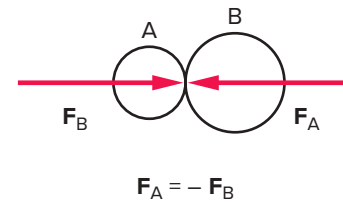
**2 Newton's first and second laws.** Newton's second law states that the acceleration of an object is proportional to the net external force acting on that object and inversely proportional to the mass of the object. The first law, the principle of inertia, describes what happens when the net force is zero. The acceleration must be zero, when the net force is zero, and the object then moves with constant velocity.



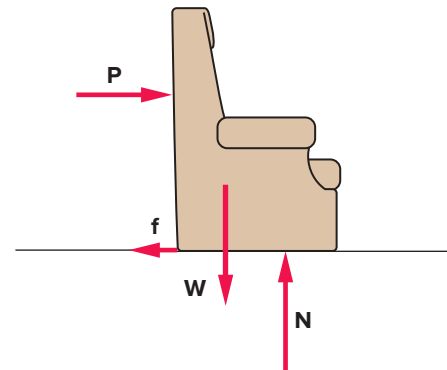
**3 Mass and weight.** Newton's second law defines the inertial mass of an object as the property that causes the object to resist a change in its motion. The weight of an object is the gravitational force acting on the object and is equal to the mass multiplied by the gravitational acceleration  $g$ . The weight of an object may vary as  $g$  varies, but mass is an inherent property of the object related to its quantity of matter.



**4 Newton's third law.** Newton's third law completes the definition of force by showing that forces result from interactions between objects. If object A exerts a force on object B, then object B exerts an equal-size but oppositely directed force on object A.



**5 Applications of Newton's laws.** In analyzing the motion of an object using Newton's laws, the first step is to identify the forces that act on the object due to interactions with other objects. The strength and direction of the net force then determine how the object's motion will change.



The study hints found on Connect are a concise summary of the chapter. You might find them useful as a review before an exam.

## Key Terms

Force, 62	Mass, 64	Action/reaction principle, 68
Newton's first law of motion, 63	Inertia, 64	Normal force, 69
Frictional forces, 63	Newton, 64	Reaction force, 69
Newton's second law of motion, 63	Weight, 66	Free-body diagram, 70
Net force, 63	Newton's third law of motion, 68	Terminal velocity, 72

## Conceptual Questions

\* = more open-ended questions, requiring lengthier responses, suitable for group discussion

Q = sample responses are available in appendix D

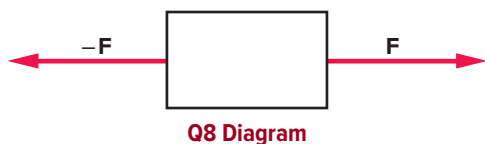
Q = sample responses are available on Connect

- Q1. Did Galileo's work on motion precede that of Aristotle or Newton? Explain.
- Q2. Why did Aristotle believe that heavier objects fell faster than lighter objects? Explain.

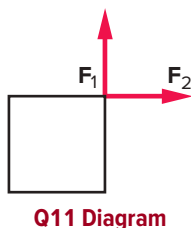
- Q3. Aristotle believed that a force was necessary to keep an object moving. Where, in his view, did this force come from in the case of a ball moving through the air? Explain.
- \*Q4. How did Aristotle explain the continued motion of a thrown object? Does this explanation seem reasonable to you? Explain.
- Q5. Did Galileo develop a more complete theory of motion than that of Newton? Explain.



- Q6.** Two equal forces act on two different objects, one of which has a mass 10 times as large as the other. Will the more massive object have a larger acceleration, an equal acceleration, or a smaller acceleration than the less massive object? Explain.
- Q7.** A 3-kg block is observed to accelerate at a rate twice that of a 6-kg block. Is the net force acting on the 3-kg block therefore twice as large as that acting on the 6-kg block? Explain.
- Q8.** Two equal-magnitude horizontal forces act on a box as shown in the diagram. Is the object accelerated horizontally? Explain.



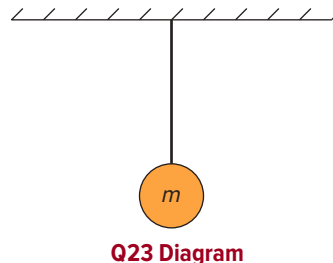
- Q9.** Is it possible that the object pictured in question 8 is moving, given the fact that the two forces acting on it are equal in size but opposite in direction? Explain.
- Q10.** Suppose that a bullet is fired from a rifle in outer space, where there are no appreciable forces due to gravity or air resistance acting on the bullet. Will the bullet slow down as it travels away from the rifle? Explain.
- Q11.** Two equal forces act on an object in the directions pictured in the diagram. If these are the only forces involved, will the object be accelerated? Explain, using a diagram.



- Q12.** An object moving horizontally across a table is observed to slow down. Is there a nonzero net force acting on the object? Explain.
- Q13.** A car goes around a curve, traveling at constant speed.
- Is the acceleration of the car zero in this process? Explain.
  - Is there a nonzero net force acting on the car? Explain.
- \*Q14.** Is Newton's first law of motion explained by the second law? Explain. Why did Newton state the first law as a separate law of motion?
- Q15.** Is the mass of an object the same thing as its weight? Explain.
- Q16.** The gravitational force acting on a lead ball is much larger than that acting on a wooden ball of the same size. When both are dropped, does the lead ball accelerate at the same rate as the wooden ball? Explain, using Newton's second law of motion.
- Q17.** The acceleration due to gravity on the moon is approximately one-sixth the gravitational acceleration near the Earth's surface. If a rock is transported from the Earth to

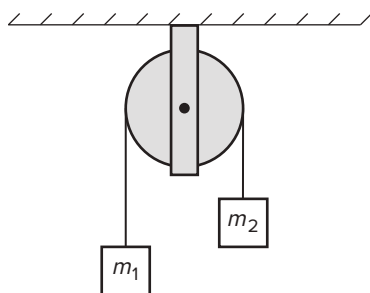
the moon, will either its mass or its weight change in the process? Explain.

- Q18.** Is mass a force? Explain.
- Q19.** Two identical cans, one filled with lead shot and the other with feathers, are dropped from the same height by a student standing on a chair.
- Which can (if either) experiences the greater force due to the gravitational attraction of the Earth? Explain.
  - Which can (if either) experiences the greater acceleration due to gravity? Explain.
- Q20.** A boy sits at rest on the floor. What two vertical forces act upon the boy? Do these two forces constitute an action/reaction pair as defined by Newton's third law of motion? Explain.
- Q21.** The engine of a car is part of the car and cannot push directly on the car in order to accelerate it. What external force acting on the car is responsible for the acceleration of the car on a level road surface? Explain.
- Q22.** It is difficult to stop a car on an icy road surface. Is it also difficult to accelerate a car on the same icy road? Explain.
- Q23.** A ball hangs from a string attached to the ceiling, as shown in the diagram.
- What forces act on the ball? How many are there?
  - What is the net force acting on the ball? Explain.
  - For each force identified in part a, what is the reaction force described by Newton's third law of motion?



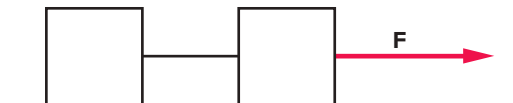
- Q24.** Would the tablecloth trick (see everyday phenomenon box 4.1) work if a bath towel were used instead of a tablecloth? Explain.
- \*Q25.** When a magician performs the tablecloth trick (see everyday phenomenon box 4.1), the objects on the table do not move very far. Is there a horizontal force acting on these objects while the tablecloth is being pulled off the table? Why do the objects not move very far? Explain.
- Q26.** A sprinter accelerates at the beginning of a 100-meter race and then tries to maintain maximum speed throughout the rest of the race.
- What external force is responsible for accelerating the runner at the beginning of the race? Explain carefully how this force is produced.
  - Once the runner reaches her maximum velocity, is it necessary to continue pushing against the track in order to maintain that velocity? Explain.
- Q27.** A mule is attempting to move a cart loaded with rock. Since the cart pulls back on the mule with a force equal in size to the force that the mule exerts on the cart (according to Newton's third law), is it possible for the mule to accelerate the cart? Explain.

- Q28. The upward normal force exerted by the floor on a chair is equal in size but opposite in direction to the weight of the chair. Is this equality an illustration of Newton's third law of motion? Explain.
- Q29. A toy battery-powered tractor pushes a book across a table. Draw separate diagrams of the book and the tractor, identifying all of the forces that act upon each object. What is the reaction force described by Newton's third law of motion for each of the forces that you have drawn?
- Q30. If you get into an elevator on the top floor of a large building and the elevator begins to accelerate downward, will the normal force pushing up on your feet be greater than, equal to, or less than the force of gravity pulling downward on you? Explain. (See everyday phenomenon box 4.2.)
- Q31. If the elevator cable breaks and you find yourself in a condition of apparent weightlessness as the elevator falls, is the gravitational force acting upon you equal to zero? Explain. (See everyday phenomenon box 4.2.)
- Q32. Two masses,  $m_1$  and  $m_2$ , connected by a string, are placed on a fixed, frictionless pulley, as shown in the diagram. If  $m_2$  is larger than  $m_1$ , will the two masses accelerate? Explain.



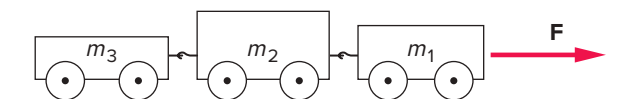
Q32 Diagram

- Q33. Two blocks with the same mass are connected by a string and are pulled across a frictionless surface by a constant force,  $\mathbf{F}$ , exerted by a string (see diagram).
- a. Will the two blocks move with constant velocity? Explain.



Q33 Diagram

- \*Q34. Suppose that a skydiver wears a specially lubricated suit that reduces air resistance to a small, constant force that does not increase as the diver's velocity increases. Will the skydiver ever reach a terminal velocity before opening her parachute? Explain.
- Q35. Does a skydiver experience constant acceleration throughout her descent from the plane to the ground?
- Q36. When a skydiver reaches the point where the upward force of air resistance is equal to her weight, does her velocity continue to increase?
- Q37. Does the force of gravity on a skydiver change as he falls toward Earth?
- Q38. You have three carts connected by strings, as shown in the diagram. Assume their masses  $m_1$ ,  $m_2$ , and  $m_3$  are different from one another. If a force,  $\mathbf{F}$ , is applied to  $m_1$ , how do their accelerations compare? Are they the same? Are they different? Explain.



Q38 Diagram

- Q39. You have three carts connected by strings, as shown in the diagram for question 38. Assume their masses  $m_1$ ,  $m_2$ , and  $m_3$  are different from one another. If a force,  $\mathbf{F}$ , is applied to  $m_1$ , how does the net force on each cart compare? Are the net forces the same? Are they different? Explain.

## Exercises

For the exercises in this chapter (and subsequent chapters), use the more accurate value of  $g = 9.8 \text{ m/s}^2$  for the acceleration due to gravity.

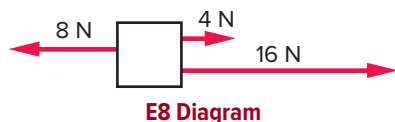
- E1. A single force of 42 N acts upon a 6-kg block. What is the magnitude of the acceleration of the block?
- E2. A heavy ball with a mass of 4.5 kg is observed to accelerate at a rate of  $7.0 \text{ m/s}^2$ . What is the size of the net force acting upon this ball?
- E3. A net force of 32 N acting upon a wooden block produces an acceleration of  $4.0 \text{ m/s}^2$  for the block. What is the mass of the block?
- E4. A 4.0-kg block being pulled across a table by a horizontal force of 70 N also experiences a frictional force of 15 N. What is the acceleration of the block?
- E5. A pulled tablecloth exerts a frictional force of 3.6 N on a plate with a mass of 0.4 kg. What is the acceleration of the plate?

- E6. A 5-kg block being pushed across a table by a force  $\mathbf{P}$  has an acceleration of  $6.0 \text{ m/s}^2$ .
- a. What is the net force acting upon the block?
- b. If the magnitude of  $\mathbf{P}$  is 38 N, what is the magnitude of the frictional force acting upon the block?
- E7. Two forces, one of 70 N and the other of 30 N, act in opposite directions upon a box, as shown in the diagram. What is the mass of the box if its acceleration is  $5.0 \text{ m/s}^2$ ?



E7 Diagram

- E8. A 5-kg block is acted upon by three horizontal forces, as shown in the diagram.
- What is the net horizontal force acting upon the block?
  - What is the horizontal acceleration of the block?



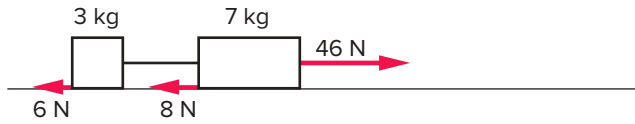
- E9. A 9-kg sled sliding freely on an icy surface experiences a 3-N frictional force exerted by the ice and an air-resistive force of 0.6 N.
- What is the net force acting upon the sled?
  - What is the acceleration of the sled?
- E10. What is the weight of a 45-kg mass?
- E11. What is the mass of a 735-N weight?
- E12. Patricia has a weight of 125 lb.
- What is her weight in newtons? (1 lb = 4.45 N)
  - What is her mass in kilograms?
- E13. One of the authors of this text has a weight of 660 N.
- What is her mass in kilograms?
  - What is her weight in pounds? (1 lb = 4.45 N)
- E14. Who has the larger mass, a woman weighing 160 lb or one weighing 690 N?
- E15. At a given instant in time, a 6-kg rock that has been dropped from a high cliff experiences an upward force of air resistance of 12 N.
- What is the gravitational force on the rock?
  - What is the net force on the rock? (Note the directions of the two forces!)
- What are the magnitude and direction of the acceleration of the rock?
- E16. At a given instant in time, a 12-kg rock is observed to be falling with an acceleration of  $6.25 \text{ m/s}^2$ .
- What are the magnitude and direction of the net force on the rock?
  - What are the magnitude and direction of the gravitational force on the rock?
  - What is the magnitude of the force of air resistance acting on the rock at this instant?
- E17. A 0.8-kg book rests on a table. A downward force of 12 N is exerted on the top of the book by a hand pushing down on the book.
- What is the net force on the book? Is it accelerating?
  - What is the magnitude of the gravitational force acting upon the book?
  - What is the magnitude of the upward (normal) force exerted by the table on the book? (Is the book accelerated?)
- E18. An upward force of 32.6 N is applied via a string to lift a ball with a mass of 2.8 kg.
- What is the gravitational force acting upon the ball?
  - What is the net force acting upon the ball?
  - What is the acceleration of the ball?
- E19. A 75-kg woman in an elevator is accelerating upward at a rate of  $0.6 \text{ m/s}^2$ .
- What is the net force acting upon the woman?
  - What is the gravitational force acting upon the woman?
  - What is the normal force pushing upward on the woman's feet? (Note: A picture of the forces on her will help.)

## Synthesis Problems

For the synthesis problems in this chapter (and subsequent chapters), use the more accurate value of  $g = 9.8 \text{ m/s}^2$  for the acceleration due to gravity.

- SP1. A constant horizontal force of 28 N is exerted by a string attached to an 8-kg block being pulled across a tabletop. The block also experiences a frictional force of 6 N due to contact with the table.
- What is the horizontal acceleration of the block?
  - If the block starts from rest, what will its velocity be after 3 seconds?
  - How far will it travel in these 3 seconds?
- SP2. A rope exerts a constant horizontal force of 350 N to pull a 40-kg crate across the floor. The velocity of the crate is observed to increase from 1 m/s to 9 m/s in a time of 2 seconds under the influence of this force and the frictional force exerted by the floor on the crate.
- What is the acceleration of the crate?
  - What is the net force acting upon the crate?
  - What is the magnitude of the frictional force acting upon the crate?
  - What force would have to be applied to the crate by the rope in order for the crate to move with constant velocity? Explain.
- SP3. A dish with a mass of 0.3 kg has a force of kinetic friction of 0.18 N exerted on it by a moving tablecloth for a time of 0.2 s.
- What is the acceleration of the dish?
  - What velocity does it reach in this time, starting from rest?
  - How far (in cm) does the dish move in this time?
- SP4. A 60-kg crate is lowered from a loading dock to the floor using a rope passing over a fixed support. The rope exerts a constant upward force on the crate of 500 N.
- Will the crate accelerate? Explain.
  - What are the magnitude and direction of the acceleration of the crate?
  - How long will it take for the crate to reach the floor if the height of the loading dock is 1.4 m above the floor?
  - How fast is the crate traveling when it hits the floor?
- SP5. Two blocks tied together by a horizontal string are being pulled across the table by a horizontal force of 46 N, as shown in the diagram. The 3-kg block has a 6-N frictional force exerted on it by the table, and the 7-kg block has an 8-N frictional force acting on it.
- What is the net force acting upon the entire two-block system?
  - What is the acceleration of this system?

- What force is exerted on the 3-kg block by the connecting string? (Consider only the forces acting upon this block. Its acceleration is the same as that of the entire system.)
- Find the net force acting upon the 7-kg block, and calculate its acceleration. How does this value compare to that found in part b?



SP5 Diagram

- SP6. An 85-kg man is in an elevator that is accelerating downward at the rate of  $1.3 \text{ m/s}^2$ .
- What is the true weight of the man in newtons?
  - What is the net force acting upon the man required to produce the acceleration?
  - What is the force exerted on the man's feet by the floor of the elevator?

- What is the apparent weight of the man in newtons? (This is the weight that would be read on the scale dial if the man were standing on a bathroom scale in the accelerating elevator.)
- How would your answers to parts b through d change if the elevator were accelerating upward with an acceleration of  $1.3 \text{ m/s}^2$ ?

- SP7. A skydiver has a weight of 850 N. Suppose that the air-resistive force acting on the diver increases in direct proportion to his velocity such that for every 10 m/s that the diver's velocity increases, the force of air resistance increases by 100 N.
- What is the net force acting upon the skydiver when his velocity is 30 m/s?
  - What is the acceleration of the diver at this velocity?
  - What is the terminal velocity of the skydiver?
  - What would happen to the velocity of the skydiver if, for some reason (perhaps a brief down draft), his velocity exceeded the terminal velocity? Explain.

## Home Experiments and Observations

- HE1. Collect a variety of small objects such as coins, pencils, keys, and bottle caps. Ice cubes, if they are available, also make excellent test objects. Try sliding these objects across a smooth surface such as a tabletop or floor, being as consistent as possible in the initial velocity that you give to them.
- Do the objects slide the same distance after they leave your hand? What differences are apparent, and how are they related to the nature of the surface and size of the objects? Which objects come closest to demonstrating Newton's first law of motion?
  - What factors seem to be important in reducing the frictional force between the objects and the surface on which they are sliding? If you see some general principle at work, test this idea by finding other objects that would support your hypothesis.
- HE2. Place a sheet of paper under a medium-sized book lying on a smooth tabletop or desktop.
- Try to accelerate the book smoothly by exerting a constant pull on the sheet of paper. What happens if you try to accelerate the book too rapidly? Can you pull the paper cleanly from underneath the book without moving the book? Explain your observations in terms of Newton's laws of motion.
  - Repeat these observations with a few books in a stack. How does increasing the mass of the books affect the results?
  - Try other objects. Which objects move the least when the paper is pulled rapidly?
- HE3. Falling objects whose surface area is large relative to their weight will reach terminal velocity more readily than a ball or a rock. Test several objects, such as a balloon, small pieces of paper, plant parts (leaves, flowers, or seeds), or anything else you think might work. Do these objects reach a terminal velocity? How far does each object fall before reaching constant velocity? How does the rate of fall differ for different objects when dropped at the same time? Which of the objects tested produces the clearest demonstration of terminal velocity, showing first a brief acceleration followed by a constant velocity?
- HE4. Using elevators in your dormitory or other campus buildings, observe the effects of the elevator's acceleration. Most elevators accelerate briefly as they start, and again as they stop (deceleration). Express elevators in high-rise buildings are best for observing the effects of acceleration.
- If you have a bathroom scale, see how much your apparent weight differs from your true weight when the elevator is stopping or starting. Can you estimate the rate of acceleration from this information? (See everyday phenomenon box 4.2 and synthesis problem 6.)
  - Try holding your arm away from your body and maintaining it in this position as the elevator accelerates. How difficult is this to do for different conditions during the motion of the elevator? Explain your observations.



# CHAPTER 5

Source: NASA/JPL

## Circular Motion, the Planets, and Gravity

---

### Chapter Overview

Using the example of a ball on a string, we first examine the acceleration involved in changing the direction of the velocity in circular motion (centripetal acceleration). Next, we consider the forces involved in producing a centripetal acceleration in different cases, including that of a car rounding a curve. Kepler's laws of planetary motion are then examined, and Newton's law of universal gravitation is introduced to explain the motion of the planets. We also show how this gravitational force relates to the weight of an object and the gravitational acceleration near the Earth's surface.

### Chapter Outline

- 1 **Centripetal acceleration.** How can we describe the acceleration involved in changing the *direction* of an object's velocity? How does this acceleration depend on the object's speed?
- 2 **Centripetal forces.** What types of forces are involved in producing centripetal accelerations in different situations? What forces are involved for a car rounding a curve?
- 3 **Planetary motion.** How do the planets move around the sun? How has our understanding of planetary motion changed historically? What are Kepler's laws of planetary motion?
- 4 **Newton's law of universal gravitation.** What is the fundamental nature of the gravitational force, according to Newton? How does this force help to explain planetary motion?
- 5 **The moon and other satellites.** How does the moon orbit the Earth? How do the orbits of artificial satellites differ from those of the moon and from those of one another?

“The car failed to negotiate the curve.” How many times have you seen a phrase like that in an accident report in the newspapers? Either the road surface was slippery or the driver was driving too fast for the sharpness of the curve. In either case, poor judgment and probably a poor sense of the physics of the situation were at work (fig. 5.1).

When a car goes around a curve, the direction of its velocity changes. A change in velocity means acceleration, and according to Newton’s second law, an acceleration requires a force. The situation has much in common with a ball being twirled in a circle at the end of a string, as well as other examples of circular motion.

What forces keep a car moving around a curve? How does the force required depend on the speed of the car and the sharpness of the curve? What other factors are involved? Finally, what does the car rounding a curve have in common with the ball on a string and the motions of the planets around the sun?

The motions of the planets around the sun and the moon around the Earth played important roles in the development of Newton’s theory of mechanics. Newton’s law of universal gravitation was a crucial part of that theory. The gravitational force explains the behavior of objects falling near the Earth’s surface, but it also explains why the



**Figure 5.1** The white SUV apparently failed to negotiate the curve and slid into the oncoming lane. How do Newton’s laws handle this situation?

*eyecrave/Getty Images*

planets move in curved paths about the sun. Circular motion is a very important special case of motion in two dimensions, both in the history of physics and in our everyday experience.

## 5.1 Centripetal Acceleration

Suppose that we attach a ball to a string and twirl the ball in a horizontal circle (fig. 5.2). With a little practice, it is not hard to keep the ball moving with a constant speed, but the direction of its velocity changes continually. A change in velocity implies an acceleration, but what is the nature of this acceleration?

The key to this situation involves taking a careful look at what happens to the velocity vector as the ball moves in a circle. How does this vector change as the path of the ball changes direction?

Can we evaluate the size of this change and how it is related to the speed of the ball or the radius of the curve? To define the concept of *centripetal acceleration*, we need to answer these questions.

### What is a centripetal acceleration?

What do we have to do to get the ball on the string to change its direction? If you try twirling a ball as pictured in figure 5.2, you will feel a tension in the string. In other words, you have to apply a force by pulling on the string to cause the change in direction of the ball’s velocity.

What would happen if this force were not present? According to Newton’s first law of motion, an object will continue moving in a straight line with constant speed if there is no net force acting on the object. If the string breaks,

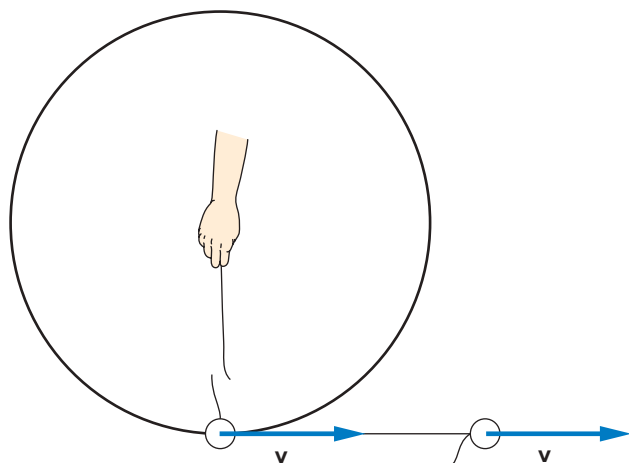


**Figure 5.2** A ball being twirled in a horizontal circle. Is the ball accelerated?

*Mark Dierker/McGraw-Hill Education*

or if we let go of the string, this is exactly what will happen. The ball will fly off in the direction in which it was traveling when the string broke (fig. 5.3). Without the pull of the string, the ball will move in a straight line. It will also fall, of course, as it is pulled down by the gravitational force.

According to Newton’s second law of motion, if there is a net force, there must be an acceleration ( $\mathbf{F}_{\text{net}} = m\mathbf{a}$ ). Acceleration can be associated with the change in the magnitude of the velocity or the *direction* of the velocity, or both. In the case of the ball on the string, the string pulls the ball toward the center



**Figure 5.3** If the string breaks, the ball flies off in a straight-line path in the direction in which it was traveling at the instant the string broke.

of the circle, causing the direction of the velocity vector to change continually. The direction of the force, and of the acceleration it produces, is *toward the center* of the circle. We call this acceleration the **centripetal acceleration**:

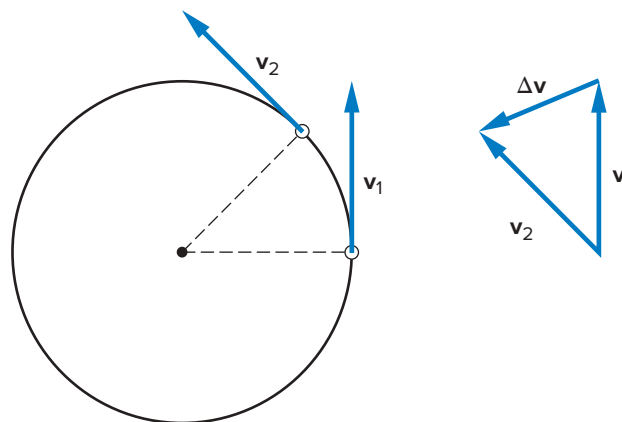
Centripetal acceleration is the rate of change in velocity of an object that is associated with the change in *direction* of the velocity. Centripetal acceleration is always perpendicular to the velocity vector itself and toward the center of the curve.

To find the size of the centripetal acceleration, we need to determine how fast the velocity is changing. You might guess that this depends on how rapidly you are twirling the ball, but it also depends on the radius of the curve—the size of the circle.

### How do we find the change in velocity $\Delta\mathbf{v}$ ?

Figure 5.4 shows the ball and string as seen from above. The ball is moving in a horizontal circle. Velocity vectors are drawn on the circle at two positions separated by a short time interval. The velocity  $\mathbf{v}_2$  occurs a short time after the velocity  $\mathbf{v}_1$ , as the ball moves counterclockwise around the circle. These two vectors are drawn with the same length, indicating that the speed of the ball is unchanged.

The change in velocity,  $\Delta\mathbf{v}$ , is the difference between the initial velocity and the final velocity for a given time interval. In other words, the change in velocity is a vector that is added to the initial velocity to produce the final velocity. Adding  $\Delta\mathbf{v}$  to  $\mathbf{v}_1$  produces  $\mathbf{v}_2$ . This vector addition is shown in the vector triangle to the right of the circle in figure 5.4. (See appendix C for a discussion of vector addition by graphical methods.)



**Figure 5.4** The velocity vectors for two positions of a ball moving in a horizontal circle. The change in velocity,  $\Delta\mathbf{v}$ , adds to  $\mathbf{v}_1$  to yield  $\mathbf{v}_2$ .

Note that the vector  $\Delta\mathbf{v}$  has a direction different from that of either of the velocity vectors. If we choose a short enough time interval between the two positions, the direction of the *change* in velocity points toward the center of the circle, the direction of the instantaneous acceleration of the ball. (Acceleration always has the same direction as the change in velocity.) The ball is being accelerated toward the center of the circle, the direction of the tension in the string. This is consistent with Newton's second law from chapter 4. Recall that the acceleration is in the direction of the net force on an object.

### What is the size of the centripetal acceleration?

How large is this centripetal acceleration, and how does it depend on the speed of the ball and the radius of the curve? The triangle illustrating the vector addition in figure 5.4 can be used to explore these questions. There are three effects to consider:

1. As the speed of the ball increases, the velocity vectors become longer, which makes  $\Delta\mathbf{v}$  longer. The triangle in figure 5.4 becomes larger.
2. The greater the speed of the ball, the more rapidly the direction of the velocity vector changes, because the ball reaches the second position in figure 5.4 more quickly.
3. As the radius of the curve decreases, the rate of change in velocity increases, because the direction of the ball changes more rapidly. A tight curve (small radius) produces a large change, but a gentle curve (large radius) produces a small change.

The first two effects indicate that the rate of change in velocity will increase with an increase in the speed of the ball. Combining these two effects suggests that the centripetal acceleration should be proportional to the square of the speed. We need to multiply by the speed twice. The third

effect suggests that the rate of change of velocity is inversely proportional to the radius of the curve. The larger the radius, the smaller the rate of change. Taken together, these effects produce the expression

$$a_c = \frac{v^2}{r}$$

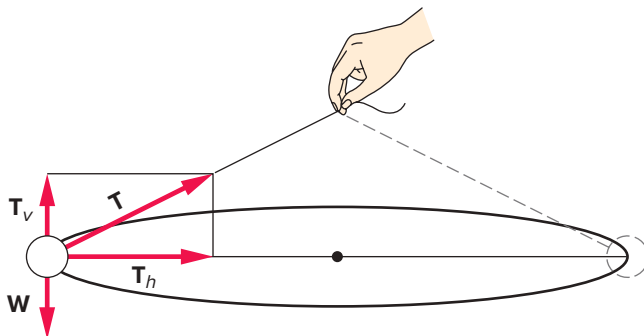
for the size of the centripetal acceleration,  $\mathbf{a}_c$ . It is proportional to the square of the speed and inversely proportional to the radius,  $r$ , of the curve. The direction of the centripetal acceleration vector  $\mathbf{a}_c$  is always toward the center of the curve, the direction of the change in velocity  $\Delta\mathbf{v}$ .

The ball moving in a circle is accelerated, even though its speed remains constant. To change the direction of the velocity vector is to change the velocity, and an acceleration is involved. People often resist this idea: We use the term *acceleration* in everyday language to describe increases in speed without taking into account changes in direction.

### What force produces the centripetal acceleration?

Because an object moving in a circle is accelerated, a force must be acting to produce that acceleration, according to Newton's second law. For the ball on the string, the tension in the string pulling on the ball provides the centripetal acceleration. A closer look shows that this tension has both horizontal and vertical components, because the string is not completely within the horizontal plane. As shown in figure 5.5, the horizontal component of the tension pulls the ball toward the center of the horizontal circle and produces the centripetal acceleration.

The total tension in the string is determined by both the horizontal and the vertical components of the tension. The vertical component is equal to the weight of the ball, because the net force in the vertical direction should be zero. The ball stays in the horizontal plane of the circle and is not accelerated in the vertical direction. In example box 5.1,



**Figure 5.5** The horizontal component of the tension,  $T_h$ , is the force that produces the centripetal acceleration. The vertical component of the tension,  $T_v$ , is equal to the weight of the ball.

## Example Box 5.1

### Sample Exercise: Circular Motion of a Ball on a String

A ball has a mass of 50 g (0.050 kg) and is revolving at the end of a string in a circle with a radius of 40 cm (0.40 m). The ball moves with a speed of 2.5 m/s, or one revolution per second. (See fig. 5.5.)

- What is the centripetal acceleration?
- What is the horizontal component of the tension needed to produce this acceleration?

$$\begin{aligned} \text{a. } v &= 2.5 \text{ m/s} & a_c &= \frac{v^2}{r} \\ r &= 0.40 \text{ m} & &= \frac{(2.5 \text{ m/s})^2}{(0.4 \text{ m})} \\ a_c &= ? & &= \mathbf{15.6 \text{ m/s}^2} \end{aligned}$$

$$\begin{aligned} \text{b. } m &= 0.05 \text{ kg} & F_{\text{net}} &= T_h = ma \\ T_h &= ? & &= (0.05 \text{ kg})(15.6 \text{ m/s}^2) \\ & & &= \mathbf{0.78 \text{ N}} \end{aligned}$$

The horizontal component of the tension must equal 0.78 N in magnitude. The vertical component of the tension must equal the weight of the ball (0.50 N), as discussed in the text.

the weight of the ball is approximately 0.50 N ( $\mathbf{W = mg}$ ), so that becomes the value of the vertical component of the tension.

The ball in example box 5.1 has a slow speed. Even at this low speed, the horizontal component of the tension is larger than the vertical component. As the ball twirls at a faster rate, the centripetal acceleration increases even more rapidly, because it is proportional to the square of the speed of the ball. The horizontal component of the tension then becomes much larger than the vertical component, which remains equal to the weight of the ball (fig. 5.6). These effects can be readily observed with your own ball and string. Give it a try. You will feel the tension increase with increasing speed.

Centripetal acceleration involves the rate of change in the direction of the velocity vector. Its size is equal to the square of the speed of the object divided by the radius of the curve ( $a_c = v^2/r$ ). Its direction is toward the center of the curve. Just as with any acceleration, there must be a force acting on the object to produce the centripetal acceleration. For a ball on a string, that force is the horizontal component of the tension in the string.





**Figure 5.7** The centripetal acceleration of a car rounding a level curve is produced by frictional forces exerted on the tires by the road surface.

Takeshi Takahara/Science Source

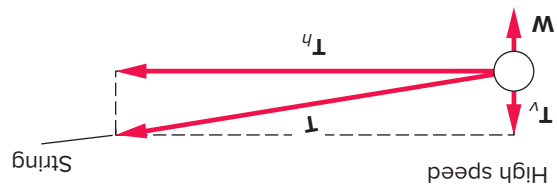
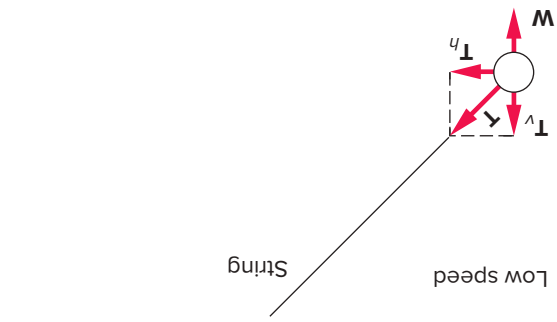
The frictional force acting on the tires points toward the center of the curve. If this force were not present, the car could not turn.

The size of a frictional force depends on whether or not there is motion along the surfaces of contact producing the friction. If there is no motion in the direction of the force, we call it the **static force of friction**. If the object is sliding, as it might on a wet or icy surface, the **kinetic force of friction** is involved. Usually, the kinetic force of friction is smaller than the maximum possible static force of friction, so whether or not the car is skidding becomes an important factor.

Unless the car has already begun to skid, the *static* force of friction produces the centripetal acceleration for the car rounding the curve. The part of the tire in contact with the road is momentarily at rest on the road; it does not slide along the road. If the tires do not move in the direction of the frictional force, the static force is in effect.

How large is the required frictional force? It depends on the speed of the car and the radius of the curve. From Newton's second law, we know that the magnitude of the required force is  $F_{\text{net}} = ma_c$ , where the centripetal acceleration  $a_c$  is equal to  $v^2/r$ . Putting these two ideas together, we see that the frictional force  $f$  must be equal to  $mv^2/r$ , because it is the only force operating to produce the centripetal acceleration. The speed of the car is a critical factor in determining how large a force is needed, which is why we often slow down when approaching a curve.

If the mass times the centripetal acceleration is greater than the maximum possible frictional force, we are in trouble. Because the square of the speed is involved in this relationship, doubling the speed would require a frictional force four times as large as that for the lower speed. Also, because we cannot control the frictional force, a sharper curve with a



**Figure 5.6** At higher speeds, the string comes closer to lying in the horizontal plane because a large, horizontal component of the tension is needed to provide the required centripetal force.

## 5.2 Centripetal Forces

For a ball twirled at the end of a string, the string pulls inward on the ball, providing the force that causes the centripetal acceleration. For a car rounding a curve, however, there is no string attached. Different forces must be at work to provide the centripetal acceleration. A person riding on a Ferris wheel also experiences circular motion. What forces produce centripetal acceleration in these situations?

The *net* force that produces a centripetal acceleration is often referred to as the **centripetal force**. This term is sometimes a source of confusion, because it implies that a special force is somehow involved. In fact, centripetal forces are *any* force, or combination of forces, that acts on an object in certain situations to *produce* the centripetal acceleration. Almost any force can play this role: pulls from strings, pushes from contact with other objects, friction, gravity, and so on. We need to analyze each situation separately to identify the forces and determine their effects.

### What force helps a car negotiate a flat curve?

What forces are involved in producing the centripetal acceleration for a car rounding a curve? It depends on whether or not the curve is banked. The easiest situation in which to analyze when a curve is not banked is a flat road surface. For a flat road surface, friction alone produces the necessary centripetal acceleration. The tendency of the car to move in a straight line causes the tires to pull against the pavement as the car turns. By Newton's third law, the pavement then pulls in the opposite direction on the tires (fig. 5.7).

smaller radius  $r$  requires a lower speed. Both the speed and the radius must be considered in making driving judgments.

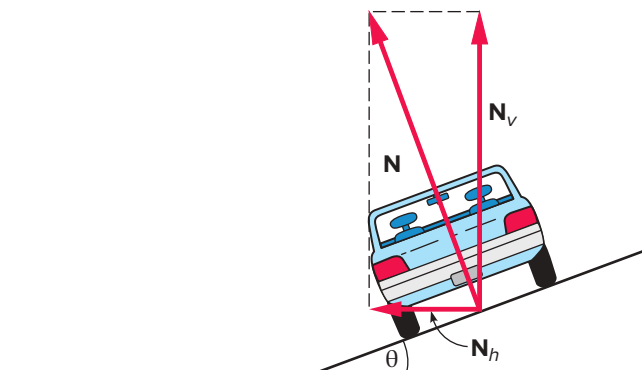
What happens if the required centripetal force is larger than the maximum possible frictional force? The frictional force cannot produce the necessary centripetal acceleration, and the car begins to skid. Once it is skidding, kinetic friction rather than static friction comes into play. Because the force of kinetic friction is generally smaller than that of static friction, the frictional force decreases and the skid gets worse. The car, like the ball on the broken string, follows its natural tendency to move in a straight line.

The maximum possible value of the frictional force is dictated by the road and tire conditions. Any factor that reduces the force of static friction will cause problems. Wet or icy road surfaces are the usual culprits. In the case of ice, the force of friction may diminish almost to zero, and an extremely slow speed will be necessary to negotiate a curve. There is nothing like driving on an icy road to give you an appreciation of the value of friction. Newton's first law is illustrated vividly. (See also everyday phenomenon box 5.1.)

### What happens if the curve is banked?

If the road surface is properly banked, we are no longer totally dependent on friction to produce the centripetal acceleration. For the banked curve, the normal force between the car's tires and the road surface can also be helpful (fig. 5.8). As discussed in chapter 4, the **normal force,  $\mathbf{N}$** , is always perpendicular to the surfaces involved, so it points in the direction shown in the diagram. The total normal force acting on the car (indicated in the diagram) is the sum of those for each of the four tires.

Because the car is not accelerated vertically, the net force in the vertical direction must be zero. The vertical component of the normal force  $\mathbf{N}_v$  must be equal in magnitude to the weight of the car to yield a net vertical force of zero. This fact determines how large the normal force will be. Only the horizontal component of the normal force  $\mathbf{N}_h$  is in the appropriate direction to produce the centripetal acceleration.



**Figure 5.8** The horizontal component of the normal force  $\mathbf{N}_h$  exerted by the road on the car can help to produce the centripetal acceleration when the curve is banked.

The angle of the banking and the weight of the car determine the size of the normal force. They also determine the size of its horizontal component. At the appropriate speed, this horizontal component pushing on the tires of the car is all that is needed to provide the centripetal acceleration. The higher the speed, the steeper the required banking angle, because a steeper angle produces a larger horizontal component for the normal force. Fortunately, because both the normal force and the required centripetal force are proportional to the mass of the car, the same banking angle will work for vehicles of different mass.

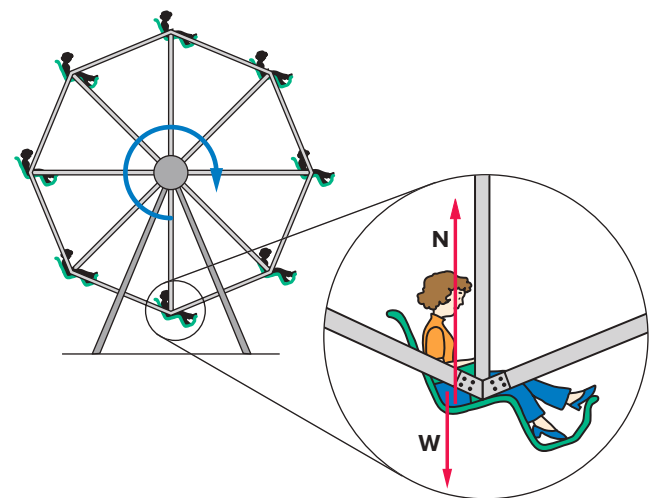
A banked curve is designed for a particular speed. Because friction is also usually present, the curve can be negotiated at a range of speeds above and below the intended speed. Friction and the normal force combine to produce the required centripetal acceleration.

If the road is icy and there is no friction, the curve can still be negotiated at the intended speed. Speeds higher than that speed will cause the car to fly off the road, just as on a flat road surface. Speeds too low, on the other hand, will cause the car to slide down the icy banked incline toward the center of the curve.

### What forces are involved in riding a Ferris wheel?

Riding a Ferris wheel is another example of circular motion that many of us have experienced. On a Ferris wheel, the circular motion is vertical, unlike the horizontal circles of our previous examples.

Figure 5.9 shows the forces exerted on the rider at the bottom of the circle as the Ferris wheel turns. At this point in the ride, the normal force acts upward and the weight downward. Because the centripetal acceleration of the rider is directed upward, toward the center of the circle, the net force acting on the rider must also be upward. In other words, the normal force of the seat pushing on the rider must be larger than the weight of the rider.



**Figure 5.9** At the bottom of the cycle, the weight of the rider and the normal force exerted by the seat combine to produce the centripetal acceleration for a rider on a Ferris wheel.

## Everyday Phenomenon

## Box 5.1

## Seat Belts, Air Bags, and Accident Dynamics

**The Situation.** In automobile accidents, serious or fatal injuries are often the result of riders' being thrown from the vehicle. Since the 1960s, federal regulations have required that cars be equipped with seat belts. Since 1998, front-seat air bags have also been required in an effort to reduce the carnage. Still, we often read of people being thrown from their vehicle in accident reports.

How do air bags and seat belts help? If your car is equipped with air bags, as most now are, is it still necessary to wear your seat belt? In what situations are air bags most effective, and when are seat belts essential?

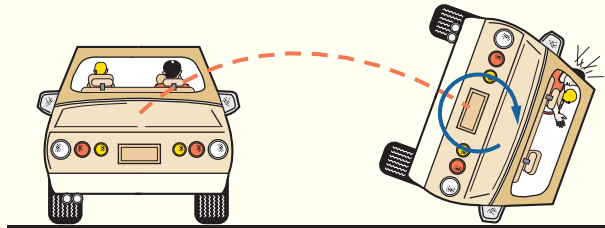
**The Analysis.** Except in high-speed collisions where the passenger compartment of the vehicle is crushed, most injuries and fatalities are caused by motion of the rider within, and outside of, the vehicle. The vehicle stops or turns suddenly due to the collision and the rider continues to move in a straight line, following Newton's first law of motion.

In a head-on collision, the car stops while the rider continues to move forward unless constrained. In the absence of either seat belts or air bags, front-seat riders hit the windshield or the steering column, resulting in serious head or chest injuries. Seat belts can prevent this when used properly, but air bags are also designed to protect against these injuries. As the rider begins to move forward relative to the vehicle, the air bag inflates rapidly, providing a cushion between the rider and other objects in the car. The rider then decelerates more gradually, involving a smaller force and less trauma. (This idea is best understood in terms of the concept of impulse, discussed in chapter 7.) Air bag usage has resulted in a significant reduction in serious head and chest injuries in head-on collisions with other vehicles or with fixed objects.

Head-on collisions are not the most frequent type of serious accident, however. Rollover accidents involving single vehicles are common, and vehicles can also collide in intersections, providing impacts



In a head-on collision, the air bag inflates rapidly to prevent the rider from moving forward and colliding with the windshield or steering column.  
*fStop Images GmbH/Alamy Stock Photo*



As the vehicle rolls, a rear-seat passenger is thrown against the side of the vehicle (viewed from the back). A properly adjusted seat belt and shoulder harness can prevent this.

to the side of the car. In the latter case, the struck vehicle will often go into a spin. In both of these cases, the vehicle undergoes rotational motion while the rider moves forward in a straight line.

These are the accidents in which the rider is likely to be thrown from the vehicle.

Will air bags help in these situations? Air bags are most effective in head-on collisions and do not provide much protection against sideways motion of the rider. (Some newer vehicles do come equipped with air bags in the front-seat doors, which can protect against sideways movement, but air bags are not usually provided for the rear seats.) In a rollover accident, the vehicle goes into a spin about an axis through its long dimension. The doors will sometimes open or the windows will shatter during the first roll, providing openings for the rider to fly through as he or she continues to move forward while the vehicle turns. In some cases, the rider is thrown from the vehicle and the vehicle then rolls over the victim.

Seat belts can make a big difference. Because the vehicle is turning rapidly in a rollover accident, a centripetal force acting on the rider is necessary to hold the rider against the seat and keep him or her from moving forward in a straight line. In the absence of such a force, the rider is thrown outward against the sides of the vehicle. Attempts by riders to brace themselves are usually totally inadequate to provide the required centripetal force. The seat belt and shoulder harness, on the other hand, can provide the force necessary to hold the rider in place.

Statistics on accident fatalities are compelling. In rollover accidents, riders who are wearing their seat belts generally survive, while those who are not using their belts and shoulder harnesses are frequently killed or seriously injured. Often, those killed are thrown from the vehicle, but even when riders remain inside the vehicle, trauma from being thrown around inside the vehicle can be fatal. Statistics indicate that a high percentage of the deaths in rollover accidents involve riders ejected from the vehicle.

Newton's first law of motion is vividly illustrated in automobile accidents. An object keeps moving in a straight line with constant speed unless acted upon by an external force. Air bags and seat belts can provide that force, but seat belts provide better protection for all passengers in rollover accidents.

According to Newton's second law, the net force must be equal to the mass times the centripetal acceleration. In this case, the centripetal force is the difference of two forces, the upward normal force and the downward weight of the rider, so

$$F_{\text{net}} = N - W = ma_c$$

Because the normal force is larger than her weight, she feels heavy in this position ( $N = W + ma_c$ ). The situation is similar to that in an upward accelerating elevator (see everyday phenomenon box 4.2).

As the rider moves up or down along the sides of the circle, a horizontal component of the normal force is needed to provide the centripetal acceleration. This horizontal component may be provided by the frictional force exerted by the seat on the rider, by the seat back pushing on the rider on the left side of the cycle, or by a seat belt or handbar on the right side of the cycle. The latter case is more exciting.

At the top of the cycle, the weight of the rider is the only force (other than a possible seat-belt force) in the appropriate direction to produce the centripetal acceleration. Again, from Newton's second law, the net force must equal the mass of the rider times the centripetal acceleration, which is now directed downward. This yields the relationship

$$F_{\text{net}} = W - N = ma_c$$

As the speed gets larger and the centripetal acceleration,  $a_c = v^2/r$ , increases, the normal force must get smaller to increase the total force. Usually, the top speed of the Ferris wheel is adjusted, so that the normal force is small when the rider is at the top of the cycle. Because the force exerted by the seat on the rider is small, the rider feels light, part of the thrill of the ride.

If there is one nearby, take a break and go ride a Ferris wheel. There is nothing like direct experience to bring home the ideas we have just described. As you ride, try to sense the direction and magnitude of the normal force. The light feeling at the top and the sense of plunging outward in the downward portion of the cycle are what the price of the ride is all about.

A centripetal force is any force or combination of forces that produces the centripetal acceleration for an object moving around a curve. In the case of a car negotiating a curve on a flat road surface, the centripetal force is provided by friction. If the road surface is banked, the normal force of the road pushing on the tires of the car also helps. In the case of a Ferris wheel, the weight of the rider and the normal force exerted by the seat on the rider combine to provide the centripetal force. We use Newton's laws of motion to identify the forces and analyze each situation.

## 5.3 Planetary Motion

Have you ever watched Venus or Mars in the night sky and wondered how and why their positions change from night to night? From the standpoint of the history of science, the motions of the planets are the most important examples of centripetal acceleration. These objects are a part of our everyday experience, yet many of us are surprisingly unaware of how they move. How do the sun, the stars, and the planets move? How can we make sense of the motions?

### Early models of the heavens

Observing the heavens was probably a more popular pastime when there were fewer roofs over our heads. If you have ever spent a night in a sleeping bag under the stars, you probably experienced a sense of wonder and amazement at all of those bright objects out there. If you spent night after night observing the stars, you might have noticed, as the ancients did, that some of the brightest objects move relative to the other stars.

These wanderers are the planets. The so-called fixed stars always maintain the same position relative to one another as they move across the sky (fig. 5.10). The Big Dipper never seems to change its shape, but the planets roam about with respect to the fixed stars in a regular but curious fashion. Their motions excited the curiosity of ancient observers of the heavens. They were carefully tracked and often incorporated into religious and cultural beliefs.

Suppose you are an early philosopher-scientist trying to make sense of these motions. What kind of model might you develop? Some features seem simple and regular. The sun, for example, moves across the sky each day, from east to west, as if it were at the end of an enormously long and invisible rope tethered at the center of the Earth. The stars



**Figure 5.10** A time-lapse photograph showing the apparent motion of stars in the northern sky. Polaris (the “North Star”) lies near the center of the pattern and does not appear to move very much. The entire pattern appears to rotate during the night around a point near Polaris. *Photo by Vincent Ting/Moment/Getty Images*

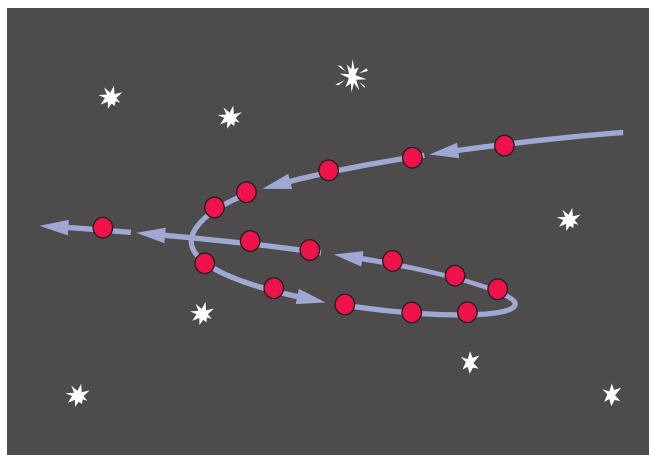
follow a similar pattern. Their apparent motion as seen from Earth could be explained by picturing them as lying on a giant sphere that revolved around the Earth. This Earth-centered, or *geocentric*, view of the universe seemed natural and reasonable.

The moon also moves across the sky in an apparently circular orbit around the Earth. Unlike the stars, the moon does not reappear in the same position each night. Instead, it goes through a series of regular changes in position and phase in a cycle of approximately 30 days. How many of us can provide a clear explanation of the phases of the moon? The motion of the moon will be considered more fully in section 5.5.

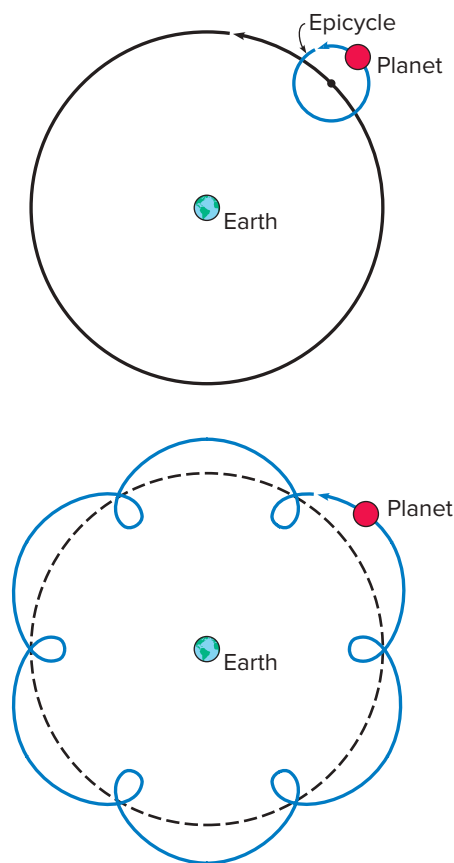
Early models of the motions of the heavenly bodies developed by Greek philosophers involved a series of concentric spheres centered on the Earth. Plato and others of his time viewed spheres and circles as ideal shapes that would reflect the beauty of the heavens. The sun, the moon, and the five planets known then each had its own sphere. The fixed stars were on the outermost sphere. These spheres were thought to revolve around the Earth in ways that explained the positions of the heavenly bodies.

Unfortunately, the planets do not behave as though they were on a continuously revolving sphere. The planets sometimes appear to move backward relative to their normal direction of motion against the background of the fixed stars. We call this **retrograde motion**. It takes a few months for Mars to trace one of these retrograde patterns (fig. 5.11).

To explain the apparent retrograde motion of these planets, Ptolemy (Claudius Ptolemaeus), working in the second century A.D., devised a more sophisticated model than the one used by earlier Greek philosophers. Ptolemy's model used circular orbits rather than spheres but was still geocentric. He invented the idea of **epicycles**, circles that rolled along the larger basic orbit of the planet around the Earth



**Figure 5.11** An example of the retrograde motion of Mars relative to the background of fixed stars. These changes take place over a period of several months.



**Figure 5.12** Ptolemy's epicycles were circles rolling along the circular orbits of the planets. This model explained the retrograde motion observed for the outer planets.

(fig. 5.12). The epicycles accounted for the retrograde motion and could be used to explain other irregularities in planetary orbits.

Ptolemy's model accurately predicted where to find the planets at any given time of any year. As more accurate observations became available, refinements were needed, however, to improve the predictions. In some cases, this meant adding epicycles to epicycles, but the basic scheme of circles was retained. Ptolemy's system became part of the accepted knowledge during the Middle Ages and was incorporated, along with many of Aristotle's works, into the teachings of the Roman Catholic Church and the emerging European universities.

### How did the Copernican model differ from Ptolemy's conception?

Ptolemy's model is not the one you were introduced to in elementary school. It has been superseded. During the sixteenth century, a Polish astronomer, Nicolaus Copernicus (1473–1543), put forth a sun-centered, or **heliocentric**, view, later championed by Galileo. Copernicus was not the

first to suggest such a model, but earlier heliocentric versions had not taken hold. Copernicus spent many years working out the details of his model, but he did not publish it until within a year of his death.

Galileo was an early advocate of the Copernican model and promoted it more vigorously than Copernicus himself. In 1610, hearing of the invention of the telescope, Galileo built his own improved version and turned it to the heavens. He discovered that the moon has mountains, that Jupiter has moons, and that Venus goes through phases like our moon. He showed that the phases of Venus could be explained better by the Copernican model than by a geocentric model. Galileo became famous throughout Europe for his discoveries and ended up in trouble with church authorities, a problem not to be taken lightly in his day. People had been burned at the stake for similar offenses.

Copernicus placed the sun at the center of the circular orbits of the planets and demoted the Earth to the status of just another planet. Also, the Copernican model requires that the Earth *rotate* on an axis through its center—thus explaining the daily motions of the sun and the other heavenly bodies (including the fixed stars). This idea was revolutionary at the time. Why are we not blown away by the enormous winds that rotation might produce? Perhaps the air near the Earth's surface is dragged along with the Earth.

The advantage of the Copernican view is that it does not require complicated epicycles to explain retrograde motion, although epicycles were still used to make other adjustments to planetary orbits. Retrograde motion comes about because the Earth is orbiting the sun along with the other planets. The position of Mars appears to change as *both* Mars and Earth move in the same direction against the background of the fixed stars (fig. 5.13). As the more rapidly moving Earth passes Mars, Mars slips behind and briefly appears to move backward.

Accepting the Copernican model meant giving up the Earth-centered view of the universe to endorse what seemed to some an absurd proposition: that the Earth rotates, with a

frequency of one cycle per day. Because an approximation of the radius of Earth was known (6400 km), rotation implied that we must be moving at roughly 1680 km/h (or just over 1000 MPH) if we are standing near the equator on the Earth! We certainly do not feel that motion.

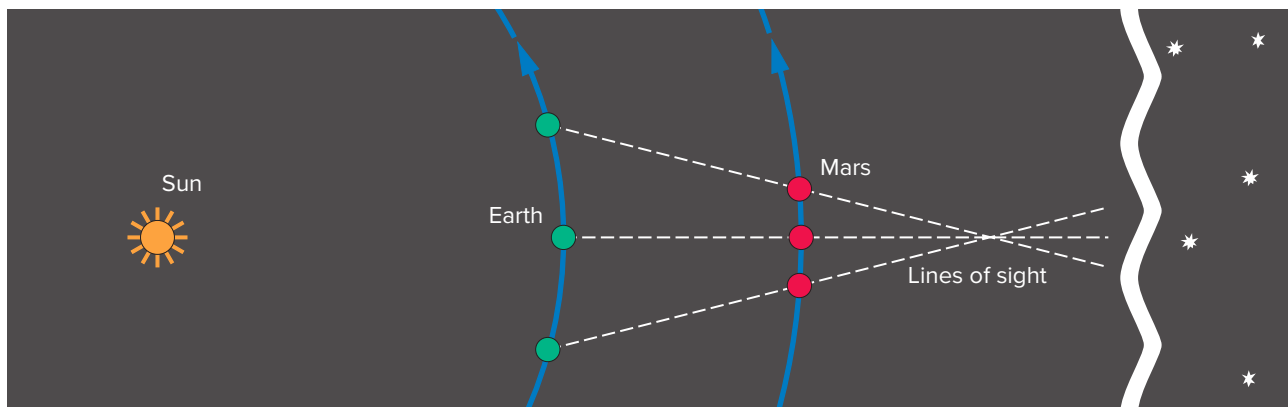
Because Copernicus assumed the planets' orbits to be circular, the accuracy of his model for predicting was no better than Ptolemy's model. In fact, it required some adjustments (for which Copernicus used epicycles) just to make it agree with already known astronomical data. Settling the controversy generated by the competition between the two models called for more accurate observations, a project undertaken by a Danish astronomer, Tycho Brahe (1546–1601).

Tycho was the last great naked-eye astronomer. He developed a large quadrant (fig. 5.14), which he used to make very accurate sightings of the positions of the planets and stars. It was capable of measuring these positions to an accuracy of  $1/60$  of a degree, considerably better than the accuracy of previously available data. Tycho spent several years painstakingly collecting data on the precise positions of the planets and other bodies—all without the benefit of a telescope.

### Kepler's laws of planetary motion

Analyzing the data collected by Tycho fell to his assistant, Johannes Kepler (1571–1630), after Tycho's death. It was an enormous task requiring the transformation of the data to coordinates around the sun and then numerical trial and error to find regular planetary orbits. It was already known that these orbits are not perfect circles. Kepler was able to show that the orbits of the planets around the sun are ellipses, with the sun at one focus.

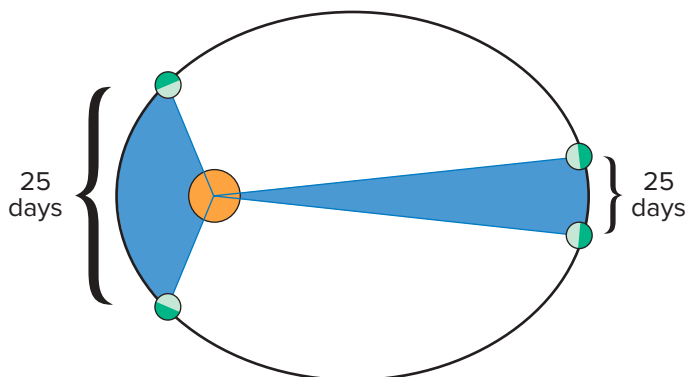
An **ellipse** can be drawn by attaching a string between two fixed foci and then moving a pencil around the perimeter of the path allowed by the string (fig. 5.15). A circle is a special case of an ellipse in which the two foci coincide. The orbits of most of the planets are very close to being circles, but Tycho's data were so precise that they



**Figure 5.13** As the Earth passes the more slowly moving Mars, Mars appears to move backward as seen against the background of the much more distant fixed stars. (Not drawn to scale.)



**Figure 5.14** Tycho Brahe's large quadrant permitted accurate measurement of the positions of the planets and other heavenly bodies. *Photo Josse/Leemage/Getty Images*

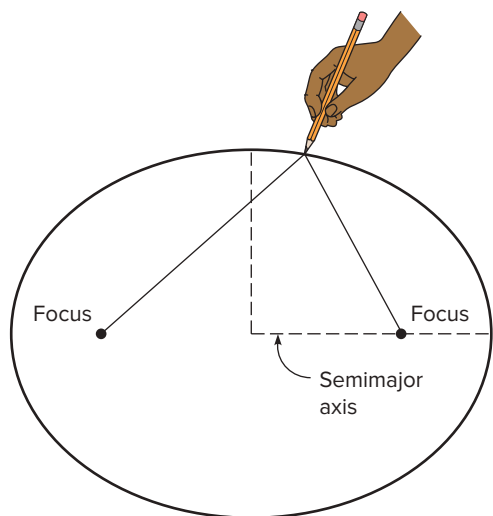


**Figure 5.16** Because planets move faster when nearer to the sun, the radius line for each planet sweeps out equal areas in equal times (Kepler's second law). In other words, the two blue sections each cover the same span of time and have the same area. (Not drawn to scale.)

Kepler's other two laws of planetary motion came after even more laborious numerical trial and error with Tycho's data. Kepler's second law describes how the planets move faster when they are nearer to the sun, so that an imaginary line drawn from the sun to the planet moves through equal areas in equal times regardless of where it is in its orbit (fig. 5.16).\* The first two laws were published in 1609.

The third law (published in 1619) states a relationship between the average radius of the orbit and the time taken for one complete cycle around the sun (the **period** of the orbit). Kepler found his third law after trying many other possible relationships between the periods,  $T$ , and the average radii of the planetary orbits,  $r$ , all without the use of a computer! To a high degree of accuracy, he found that the ratio of the square of the period to the cube of the radius ( $T^2/r^3$ ) was the same for all of the known planets (see example box 5.2). The behavior of the planets is surprisingly regular. Kepler published his findings in papers that also contained elaborate speculations on numerical mysticism and musical harmonies associated with the planets. Some of these ideas must have seemed strange to Galileo and others who admired Kepler's work.

Kepler's laws added to the accuracy with which we can predict the positions of the planets as they appear to wander among the fixed stars. Like the Copernican model, Kepler's model was heliocentric (sun-centered), so it supported Galileo's efforts to overthrow the geocentric (Earth-centered) model of Ptolemy. More important, however, Kepler's laws described a new set of precisely stated relationships that called for explanation. The stage was set for Isaac Newton to incorporate these relationships into a grand theory that



**Figure 5.15** An ellipse can be drawn by fixing a string at two points (foci) and moving a pencil around the path permitted by the string.

showed a difference between a perfect circle, on one hand, and an ellipse with two closely spaced foci. Kepler's first law of planetary motion states that the orbits of the planets are ellipses.

\*The second law turns out to be a consequence of conservation of angular momentum, which is discussed in chapter 8.

## Example Box 5.2

### Sample Exercise: Using Kepler's Third Law

How long does it take Mars to complete one orbit around the sun? The distance of Mars from the sun is approximately 1.5 astronomical units (AU). (An AU is the average distance from the Earth to the sun; thus, the radius of the Earth's orbit,  $r_{\text{Earth}}$ , is just 1 AU.)

$$r_{\text{Earth}} = 1 \text{ AU} = \text{the distance from Earth to the sun}$$

$$r_{\text{Mars}} = 1.5 \text{ AU} = \text{the distance from Mars to the sun}$$

$$T_{\text{Earth}} = 1 \text{ Earth year (yr)}$$

$$T_{\text{Mars}} = ? \text{ (in Earth years)}$$

Kepler's third law for this case can be stated as

$$\frac{r_{\text{Mars}}^3}{T_{\text{Mars}}^2} = \frac{r_{\text{Earth}}^3}{T_{\text{Earth}}^2}$$

Cross multiplying, we find  $(r_{\text{Earth}}^3)(T_{\text{Mars}}^2) = (r_{\text{Mars}}^3)(T_{\text{Earth}}^2)$ .

Therefore,

$$T_{\text{Mars}}^2 = \frac{(r_{\text{Mars}}^3)(T_{\text{Earth}}^2)}{r_{\text{Earth}}^3}$$

Inserting the values for the planets listed above,

$$T_{\text{Mars}}^2 = \frac{((1.5 \text{ AU})^3)((1 \text{ yr})^2)}{(1 \text{ AU})^3},$$

$$T_{\text{Mars}}^2 = 3.4 \text{ yr}^2 \text{ (notice that the AU units cancel)}$$

$$T_{\text{Mars}} = \sqrt{3.4 \text{ yr}^2} \approx \mathbf{1.8 \text{ Earth years}}$$

explains both celestial mechanics (the motion of the heavenly bodies) and the more mundane motion of everyday objects near the Earth's surface.

### Kepler's Laws of Planetary Motion

1. The planets all move in elliptical orbits about the sun, with the sun located at one focus of the ellipse.
2. An imaginary line drawn from the sun to any planet moves through equal areas in equal intervals of time.
3. If  $T$  is the amount of time taken for the planet to complete one full orbit around the sun (*period*) and if  $r$  is the average radius of the distance of the orbit around the sun for each planet, then the ratio of the square of the period to the cube of the radius ( $T^2/r^3$ ) is the same for all of the known planets.

Many of the early models for describing the motion of the planets were geocentric (Earth-centered). Ptolemy's model included epicycles to explain the apparent retrograde motion of the planets. Copernicus introduced a heliocentric (sun-centered) model, which explained retrograde motion more simply. This model was championed by Galileo. Galileo was one of the first scientists to use a telescope systematically, and he made significant discoveries supporting the heliocentric view. Kepler refined the heliocentric model by showing that planetary orbits are ellipses with some surprising regularities.

## 5.4 Newton's Law of Universal Gravitation

Planetary motion and centripetal acceleration lead us to the next question. If the planets are moving in curved paths around the sun, what force must be present to produce the centripetal acceleration? You are probably aware that gravity is involved, but that involvement was not at all obvious when Newton began his work. How did Newton put it all together?

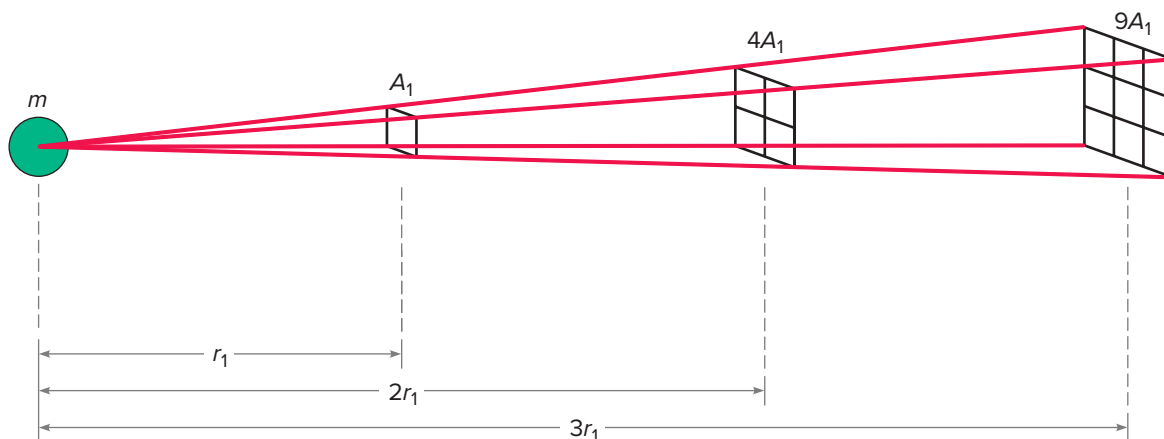
### What was Newton's breakthrough?

Newton realized that there is a similarity between the motion of a projectile launched near the Earth's surface and the orbit of the moon. To illustrate this point, Newton produced a famous drawing similar to that shown in figure 5.17.



**Figure 5.17** In a diagram similar to this, Newton imagined a projectile fired from an incredibly high mountain. If fired with a large enough horizontal velocity, the projectile falls toward the Earth but never gets there.





**Figure 5.18** If lines are drawn radiating outward from a point mass, the areas intersected by these lines increase in proportion to  $r^2$ . Does this suggest that the force exerted by the mass on a second mass might become weaker in proportion to  $1/r^2$ ?

The idea is simple but earthshaking. Imagine, as Newton did, a projectile being launched horizontally from an incredibly high mountain. The larger the launch velocity, the farther away from the base of the mountain the projectile will land. At very large launch velocities, the curvature of the Earth becomes a significant factor. In fact, if the launch velocity is large enough, the projectile will never reach the Earth’s surface. It keeps falling, but the curvature of the Earth falls away, too. The projectile goes into a circular orbit around the Earth.

Newton’s insight was that the moon, under the influence of gravity, is actually falling, just as a projectile does. The moon, of course, is at a distance from the Earth much greater than the height of any mountain. The same force that accounts for the acceleration of objects near the Earth’s surface, as described by Galileo, explains the orbit of the moon.

### Newton’s explanation of Kepler’s laws

From Galileo’s work, Newton knew that near the Earth’s surface the gravitational force is proportional to the mass of the object,  $F = mg$ . Mass, then, should be involved in any more general expression for the gravitational force.

Does the gravitational force vary with distance, though, and, if so, how? The idea that a force could influence two masses separated by a large distance was hard to accept in Newton’s day (and, in some ways, is hard to accept even now). If such a force exists, we would expect that this force “acting at a distance” would decrease in strength as the distance increased. Using geometrical reasoning (fig. 5.18), other scientists had speculated that the force might be inversely proportional to the square of the distance  $r$  between the masses, but they could not prove it.

At this point, Kepler’s laws of planetary motion and the concept of centripetal acceleration came into play. Newton was able to prove mathematically that Kepler’s first and third laws of planetary motion could be derived

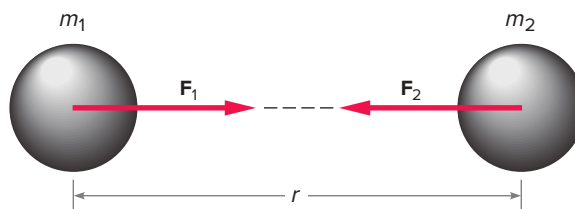
from the assumption that the gravitational force between the planets and the sun falls off with the inverse square of the distance. The proof involved setting the assumed  $1/r^2$  force equal to the required centripetal force in Newton’s second law of motion. All of Kepler’s laws are consistent with this assumption.

The proof that Kepler’s laws could be explained by a gravitational force proportional to the masses of two interacting objects, and inversely proportional to the square of the distance between the objects, led to **Newton’s law of universal gravitation**. This law and Newton’s three laws of motion are the fundamental postulates of his theory of mechanics. The law of gravitation can be stated as follows:

The gravitational force between two objects is proportional to the mass of each object and inversely proportional to the square of the distance between the centers of the masses:

$$F = \frac{Gm_1m_2}{r^2}$$

where  $G$  is a constant. The direction of the force is attractive and lies along the line joining the centers of the two masses (fig. 5.19).



**Figure 5.19** The gravitational force is attractive and acts along the line joining the center of the two masses. It obeys Newton’s third law of motion ( $F_2 = -F_1$ ).

For this statement to be completely valid, the masses in question must be either point masses or perfect spheres.

In Newton's law of gravitation,  $G$  is the **universal gravitational constant**. It has the same value for any two objects. Newton did not actually know the value of this constant, because he did not know the masses of the Earth, the sun, and the other planets. Its value was determined more than a hundred years later in an experiment done by Henry Cavendish (1731–1810) in England. Cavendish measured the very weak gravitational force between two massive lead balls for different distances of separation. In metric units, the value of  $G$  is

$$G = 6.67 \times 10^{-11} \text{ N}\cdot\text{m}^2/\text{kg}^2$$

The power-of-10 notation (see appendix B) is useful here, because  $G$  is a very small number. The power  $-11$  means that the decimal point is located 11 places to the left of where it is shown. If we did not use power-of-10 notation, the number would appear as

$$G = 0.000\,000\,000\,066\,7 \text{ N}\cdot\text{m}^2/\text{kg}^2$$

Because of the small size of this constant, the gravitational force between two ordinary-sized objects, such as people, is extremely small and not usually noticeable. Cavendish's experiment required ingenuity to measure such a weak force.

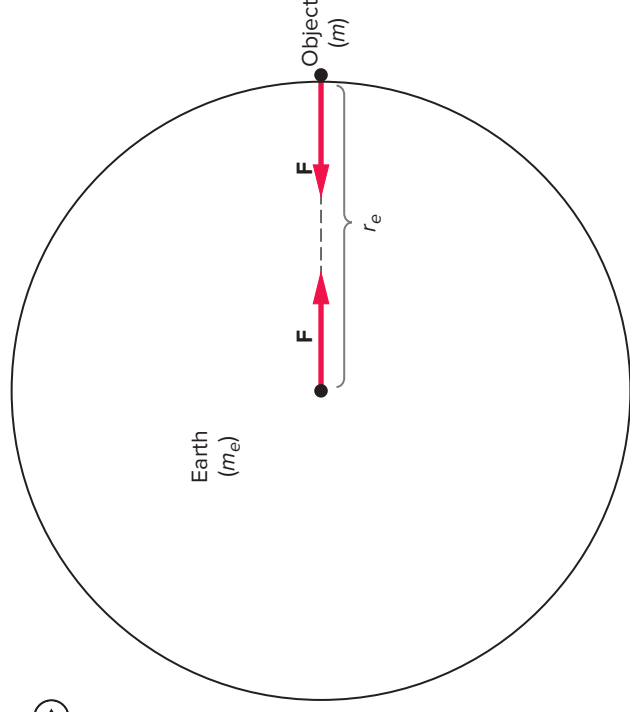
### How is weight related to the law of gravitation?

Suppose that one of the masses is a planet or other very large object. The force of gravity then can be quite large because one of the masses is very large. Consider the force exerted on a person standing on the surface of the Earth. As figure 5.20 illustrates, the distance between the centers of the two objects, the person and the Earth, is essentially the radius of the Earth,  $r_e$ .

From Newton's law of gravitation, the force on the person must be  $F = Gmm_p/r_e^2$ , where  $m$  is the mass of the person and  $m_e$  is the mass of Earth. Because this gravitational force is the weight of the person, we can also express the force as  $F = W = mg$ . For these two expressions for  $F$  to be the same,  $g$ , the gravitational acceleration, must be related to the universal gravitational constant  $G$  by  $g = Gm_e/r_e^2$ .

The gravitational acceleration near the Earth's surface  $g$  is therefore *not* a universal constant. It will be different on different planets and even slightly different at different points on the Earth because of variations in the radius of the Earth and other factors. The constant  $G$  is a universal constant of nature that can be used to find the gravitational acceleration for any planet if we know the radius and mass of the planet.

If we know the gravitational acceleration near the Earth's surface, it is easier to use the expression  $\mathbf{F} = m\mathbf{g}$  to compute a weight than to use the law of universal gravitation. This computation is done both ways in the sample exercise in example box 5.3. Either way, we get the same result. (When dealing with weight, we will use  $g = 9.8 \text{ m/s}^2$ , instead of the



**Figure 5.20** For the Earth and an object near the Earth's surface, the distance between the centers of the two objects is equal to the radius of the Earth.

approximation of  $10 \text{ m/s}^2$ , to obtain more accurate values.) The weight of the 50-kg person is approximately 490 N. The mass of Earth,  $5.98 \times 10^{24} \text{ kg}$ , is a very large number that was first determined by Cavendish when he measured the universal constant  $G$ . In a sense, Cavendish weighed the Earth by making that measurement.

### Example Box 5.3

#### Sample Exercise: Gravity, Your Weight, and the Weight of the Earth

The mass of the Earth is  $5.98 \times 10^{24} \text{ kg}$ , and its average radius is 6370 km. Find the gravitational force (the weight) of a 50-kg person standing on Earth's surface

- By using the gravitational acceleration.
- By using Newton's law of gravitation.

$$\begin{aligned} \text{a. } m &= 50 \text{ kg} & F &= W = mg \\ g &= 9.8 \text{ m/s}^2 & &= (50 \text{ kg})(9.8 \text{ m/s}^2) \\ F &=? & &= \mathbf{490 \text{ N}} \end{aligned}$$

$$\begin{aligned} \text{b. } m_e &= 5.98 \times 10^{24} \text{ kg} \\ r_e &= 6.37 \times 10^6 \text{ m} \\ F &= W = Gmm_p/r_e^2 \\ &= \frac{(6.67 \times 10^{-11} \text{ N}\cdot\text{m}^2/\text{kg}^2)(50 \text{ kg})(5.98 \times 10^{24} \text{ kg})}{(6.37 \times 10^6 \text{ m})^2} \\ &= \mathbf{490 \text{ N}} \end{aligned}$$

Most scientific calculators will handle the scientific notation directly. The powers add for multiplication and subtract in division.

If we wanted to know the gravitational force exerted on a 50-kg person in a space capsule several hundred kilometers above the Earth, we would have to use the more general expression in Newton's law of gravitation. Likewise, if we wanted to know the weight of this person when standing on the moon, we would need to use the mass and radius of the moon in place of those of the Earth in our calculation. The weight of a 50-kg person on the moon is only about one-sixth the value of 490 N that we computed for the same person standing on Earth. The expression  $F = mg$  is valid *only* near the surface of the Earth.

The weaker gravitational force and acceleration of the moon are explained by the moon's smaller mass. Because our muscles are adapted to conditions on Earth, we would find that our smaller weight on the moon makes some amazing leaps and bounds possible. The smaller gravitational force on objects near the moon's surface also explains why the moon has essentially no atmosphere. Gas molecules escape the gravitational pull of the moon much more easily than that of Earth.

Newton recognized that the moon is falling toward the Earth much like projectiles moving near the Earth's surface. He proposed that the gravitational force that explains projectile motion is also involved in the motions of the planets around the sun and of the moon around the Earth. Newton's law of universal gravitation states that the gravitational force between two masses is proportional to the product of the masses and inversely proportional to the square of the distance between them. Using this law and his laws of motion, Newton was able to explain Kepler's laws of planetary motion, as well as the motion of ordinary objects near the Earth's surface.

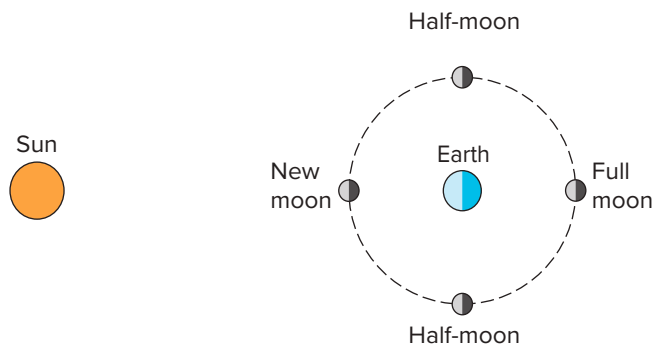
## 5.5 The Moon and Other Satellites

The moon has fascinated people as long as humanity has existed and wondered about nature. In the twentieth century, we actually visited the moon for the first time and brought back samples from its surface. That visit has not dulled the romance that the moon holds for us, but it may have reduced its mystery.

How are the *phases of the moon* associated with changes in its position? Are Kepler's laws of planetary motion valid for the moon? How are the orbits of other satellites of Earth similar to the moon's?

### How do we explain the phases of the moon?

The moon was the only Earth satellite available to Newton and his predecessors to study. The moon played a pivotal role in Newton's thinking and in the development of his law of gravitation. Observations of the moon and its phases, however, go back much further than Newton's day. The moon figures in many early religions and rituals. Its



**Figure 5.21** The phases of the moon depend on the positions of the sun, the moon, and the Earth. (Not drawn to scale.)

course must have been carefully followed even in prehistoric times.

How do we explain the **phases of the moon**? Is the time that the moon rises in the evening related to whether it will be a full moon or not? Moonlight is reflected sunlight. So to understand the moon's phases, we have to take into account the positions of the sun, the moon, and the observer (fig. 5.21). When the moon is full, it is on the opposite side of the Earth from the sun, and we see the side that is fully illuminated by the sun. The full moon rises in the east about the same time that the sun sets in the west. These events are determined by the Earth's rotation.

Because Earth and the moon are both small compared to the distances between Earth, the moon, and the sun, they do not usually get in the way of light coming from the sun. When they do, however, there is an **eclipse**. During a *lunar eclipse*, Earth casts a full or partial shadow on the moon. From figure 5.21, we can see that a lunar eclipse can only occur during a full moon. A *solar eclipse* happens when the moon is in the right position to cast a shadow on the Earth. During what phase of the moon will this occur?

At other times during the moon's 27.3-day revolution around the Earth, we do not see all of the illuminated side of the moon; we see a crescent, a half-moon, or some shape in between (fig. 5.22). The new moon occurs when the moon is on the same side of Earth as the sun and is more or less invisible. When we are a few days on either side of the new moon, we see the familiar crescent.



**Figure 5.22** Photographs of different phases of the moon. When during the day will each rise and set? *somchaisom/Stock/360/Getty Images*

When the moon is between full moon and new moon, it can often be seen during daylight. In particular, when it is near half-moon, it rises around noon and sets around midnight (or vice versa, depending on where it is in its cycle). Under just the right conditions near sunset or sunrise, we can sometimes see the dark portion of the crescent moon illuminated by earthshine.

The next time you see the moon, think about where it is in the sky, when it will rise and set, and how this is related to its phase. Better yet, try explaining this to a friend. You, too, can be the wizard who predicts the motions of the heavens.

### Does the moon obey Kepler's laws?

The moon's orbit around Earth is more complicated than those of the planets, because two bodies, Earth and the sun, exert strong forces on the moon, rather than just one (fig. 5.23). Earth is much closer to the moon than the sun is, but the sun has a much larger mass than Earth, so the sun's effect is still appreciable. First, let's consider just the effects of Earth on the moon's motion.

The physics of the situation is the same as that for the orbits of the planets around the sun. The gravitational attraction between the moon and Earth provides the centripetal acceleration to keep the moon moving in its roughly circular orbit. By Newton's law of gravitation, the gravitational force acting on the moon is proportional to  $1/r^2$ , where  $r$  is the distance between the center of the moon and the center of Earth. The tides can be explained by this dependence of the gravitational force on distance. (See everyday phenomenon box 5.2.)

Like the planets, the moon's orbit is an ellipse, but with the Earth at one focus of the ellipse rather than the sun. The sun also exerts a force on the moon that distorts the ellipse, causing the moon's orbit around Earth to oscillate about a true elliptical path as the moon and Earth orbit together around the sun. Calculating these oscillations was a problem that kept mathematical physicists busy for many years.

Kepler's first and second laws of planetary motion are approximately true for the moon, provided that we substitute the Earth for the sun in the statement of these laws. Kepler's third law shows some differences between the moon and the planets. When Newton derived the expression for the ratio in

Kepler's third law, he arrived at the expression

$$\frac{T^2}{r^3} = \frac{4\pi^2}{Gm_s}$$

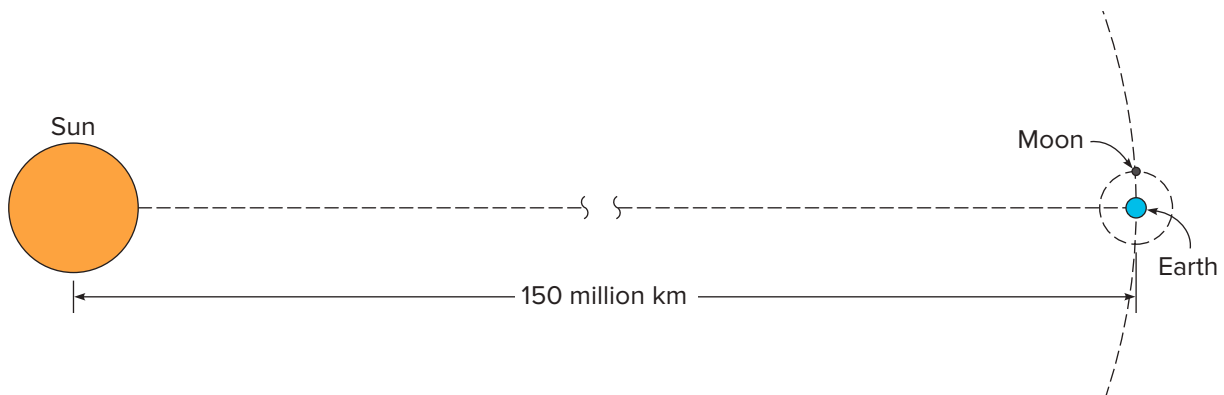
where  $m_s$  is the mass of the sun. For the moon, we would replace the mass of the sun with the mass of Earth. We get a different ratio for the moon's orbit around Earth than for the orbits of the planets around the sun.

### Orbits of artificial satellites

Any satellite orbiting the Earth must have the same value for the ratio  $T^2/r^3$  as the moon. Kepler's third law holds for any satellite of Earth, then, as long as we keep in mind that the ratio will not have the same value as it does for the orbits of the planets. The value of this ratio for Earth satellites is calculated either from the Earth's mass or from the values of the period and average distance of the moon's orbit.

Any artificial satellite of Earth must have the same value for this ratio. If its distance from the center of the Earth  $r$  is smaller than the moon's distance, its orbital period  $T$  must also be smaller to keep the ratio  $T^2/r^3$  the same. Using this ratio, we can calculate the appropriate distance from Earth for any satellite if we know its orbital period. For example, a satellite with a **synchronous orbit** has a period of 24 hours, which keeps it above the same point on the Earth as Earth rotates. From the third-law ratio, we find a distance  $r$  of 42,000 km for such a satellite (measured from the center of the Earth). Because Earth's radius is 6370 km, this is roughly seven times the radius of the Earth. This is quite a ways up, but not nearly as high as the moon (which is approximately 384,400 km away from the Earth).

Most artificial satellites are even closer to the Earth. The original Russian satellite, *Sputnik*, for example, had a period of about 90 minutes, or 1.5 h. Using the third-law ratio, this yields an average distance from the center of the Earth of 6640 km. Subtracting Earth's radius, 6370 km, indicates that this distance is only 270 km above the Earth's surface. The shorter the period, the closer the satellite is to the Earth. The orbital period cannot be much shorter than *Sputnik*'s before atmospheric drag becomes too large for motion to be sustained. Obviously, the orbit cannot have a radius smaller than Earth's radius.



**Figure 5.23** The moon is influenced by gravitational attraction to both the Earth and the sun. (Distances and sizes not drawn to scale.)

## Everyday Phenomenon

## Box 5.2

### Explaining the Tides

**The Situation.** Anyone who has lived near the ocean is familiar with the regular variation of the tides. Roughly twice a day the tides come in and go out again. The actual cycle of two high tides and two low tides is closer to 25 hours. Sometimes high tide is higher and low tide is lower than at other times—these times correspond to the full moon or the new moon.

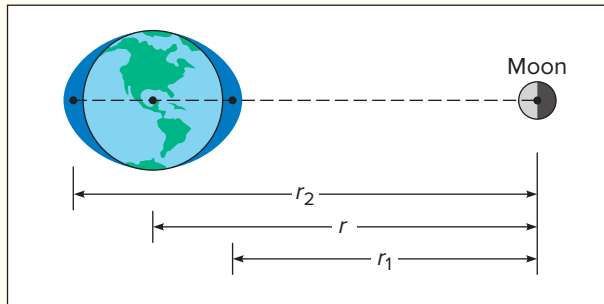
The times when high tides and low tides happen shift from day to day because of their 25-hour cycle, but the pattern repeats monthly. How do we explain this behavior?

**The Analysis.** The monthly cycle and the correlations of the highest tides with the phase of the moon suggest a lunar influence. Both the moon and the sun exert gravitational forces on the Earth. The sun exerts the stronger force because of its much larger mass, but the moon is much closer, and variations in its distance from Earth may be significant. The gravitational force depends on  $1/r^2$ , so its strength will vary as the distance  $r$  varies, as indicated in the drawing shown below.

Because water is a fluid (except when frozen), the water that makes up the oceans moves over the more rigid crust of Earth. The primary force acting on the water is the gravitational attraction of Earth that holds the water to the Earth's surface. The gravitational force exerted by the moon on the water is also significant, however, and its strength per unit mass is greatest on the side of Earth closest to the moon and weakest on the opposite side of Earth because of the difference in distance.

This difference in strength of the moon's pull produces a bulge in the water surface on both sides of the Earth. The bulge on the side nearest the moon results from the water's being pulled toward the moon by a stronger force per unit mass than the force per unit mass exerted on the rest of the Earth. This produces a high tide. The water will rise nearer to the top of the dock.

On the opposite side of the Earth, it is the Earth that is being pulled by the moon with a stronger force per unit mass than the water. Because the Earth is pulled away (slightly) from the water, this also produces a high tide. The forces exerted by the moon



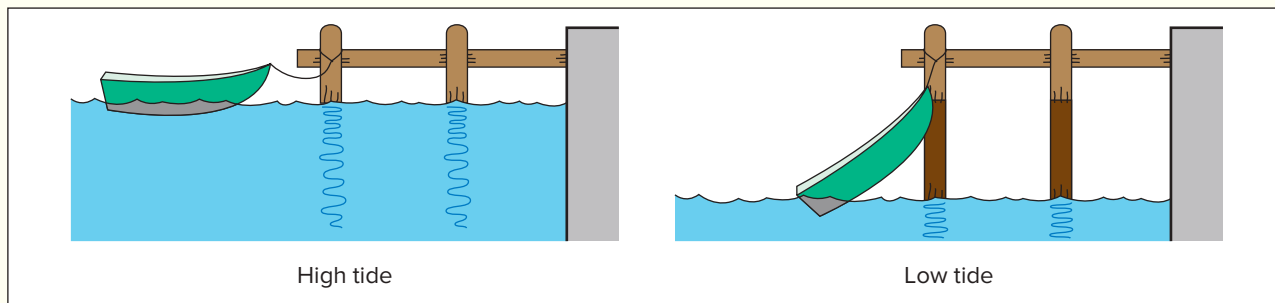
Because it depends on distance, the gravitational force per unit mass exerted by the moon on different parts of the Earth (and water in the oceans) gets weaker as we move from the side nearer the moon to the far side. (Not drawn to scale; the bulges here are greatly exaggerated.)

are small compared to the force that the water and the Earth exert on each other but are still large enough to produce the tides.

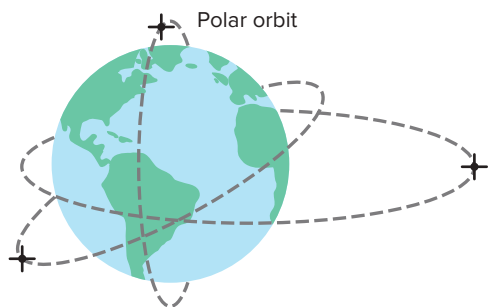
When the sun and the moon both line up with the Earth during the new moon or full moon, the sun also contributes to this difference in forces and produces bulges on either side of the Earth, adding to those produced by the moon. The highest tides occur during a full moon or a new moon because of this combination of the moon and sun.

Why is the cycle 25 hours rather than 24 hours? The high-tide bulges occur on either side of Earth along the line joining the moon and the Earth. The Earth rotates underneath these bulges with a period of 24 hours, but in this time, the moon also moves, because it orbits Earth with a period of 27.3 days. In 1 day, therefore, the moon has moved through roughly  $1/27$  of its orbital cycle, causing the time when the moon again lines up with a given point on Earth to be a little longer than 1 day. This additional time is approximately  $1/27$  of 24 hours, or a little less than an hour.

This model was conceived by Newton and accounts neatly for the major features of the tides. The variation of the gravitational force with distance is the key to the explanation.



High tide and low tide produce different water levels at the dock.



**Figure 5.24** The orbits of different artificial satellites can have different orientations and elliptical shapes.

The orbits of different satellites are planned to meet different objectives. Some are close to circular, while others are much more elongated ellipses (fig. 5.24). The plane of the orbit can pass through the poles of the Earth (polar orbit) or take any orientation between the poles and the equator. It all depends on the mission of the satellite.

Artificial satellites have become a routine feature of today's world that did not exist before 1958, when *Sputnik* was launched. Their uses are many, including communications, surveillance, weather observations, and various military applications. The basic physics of their behavior is accounted for by Newton's theory. If Newton could return, he might be amazed at the developments, but for him the analysis would be routine.

The motion of the moon around Earth is governed by the same principles as that of the planets around the sun. The gravitational force provides the centripetal acceleration that keeps the moon in an approximately elliptical orbit. The moon is illuminated primarily by the sun, and the phases of the moon can be explained by the moon's position with regard to the sun and Earth. The full moon occurs when the sun and moon are on opposite sides of the Earth. Other satellites of Earth are governed by these principles, but Kepler's third-law ratio has a different value for satellites of Earth (including the moon) than for the planets. The moon is no longer alone; it has been joined by many, much smaller objects buzzing around the Earth in lower orbits.

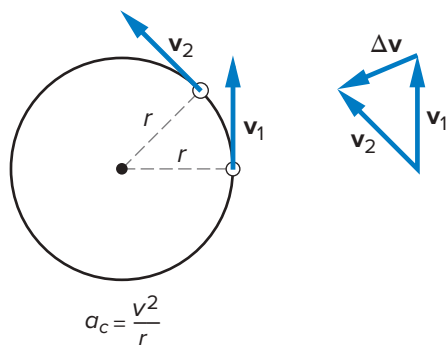
### Debatable Issue

Some people believe that the moon landing in 1969 was just an elaborate hoax. Is this a reasonable belief? What evidence or arguments could you use to counter this claim?

## Summary

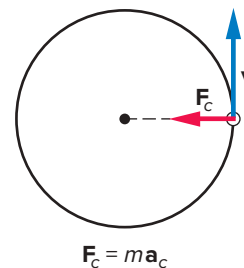
Objects moving in circular paths are accelerated, because the direction of the velocity vector continually changes. The forces involved in producing this centripetal acceleration were examined for the motion of a ball on a string, cars rounding curves, a rider on a Ferris wheel, and finally the planets moving around the sun. The force providing the centripetal acceleration for planetary motion is described by Newton's law of gravitation.

**1 Centripetal acceleration.** Centripetal acceleration is the acceleration involved in changing the direction of the velocity vector. It is proportional to the square of the speed of the object and inversely proportional to the radius of the curve.

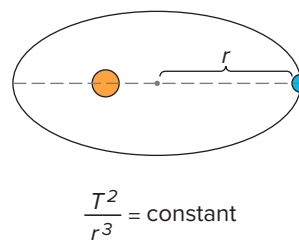


**2 Centripetal forces.** A centripetal force is any force or combination of forces that acts on a body to produce the centripetal

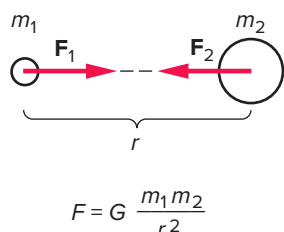
acceleration, including friction, normal forces, tension in a string, or gravity. The net force is related to the centripetal acceleration by Newton's second law.



**3 Planetary motion.** Kepler's three laws of planetary motion describe the orbits of the planets around the sun. The orbits are ellipses that sweep out equal areas in equal times (the first and second laws). The third law states a relationship between the period of the orbit and the distance of the planet from the sun.

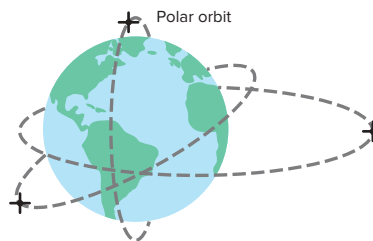


**4 Newton’s law of universal gravitation.** Newton’s law of universal gravitation states that the gravitational force between two masses is proportional to each of the masses and inversely proportional to the square of the distance between the masses. Using this law with his laws of motion, Newton could derive Kepler’s laws of planetary motion.



**5 The moon and other satellites.** The moon’s orbit around Earth can also be described by Kepler’s laws, provided we substitute the mass of Earth for that of the sun in the expression for

the period. Artificial satellites have the same ratio  $T^2/r^3$  as that for the moon.



If you find it challenging to use the equations for Newton’s law of universal gravitation and Kepler’s third law, try the practice problems in Connect. Complete solutions (not just the answers) are provided, which should help you improve your ability to “plug and chug”!

## Key Terms

Centripetal acceleration, 82	Retrograde motion, 88	Newton’s law of universal gravitation, 92
Centripetal force, 84	Epicycle, 88	Universal gravitational constant, 93
Static force of friction, 84	Heliocentric, 88	Phases of the moon, 94
Kinetic force of friction, 84	Ellipse, 89	Eclipse, 94
Normal force, 85	Period, 90	Synchronous orbit, 95

## Conceptual Questions

\* = more open-ended questions, requiring lengthier responses, suitable for group discussion

Q = sample responses are available in appendix D

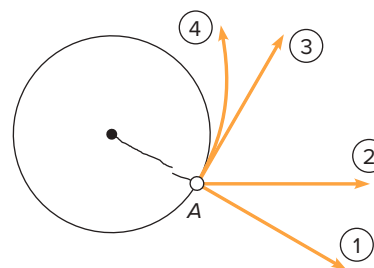
Q = sample responses are available on Connect

- Q1. Suppose that the speed of a ball moving in a horizontal circle is increasing at a steady rate. Is this increase in speed produced by the centripetal acceleration? Explain.
- Q2. A car travels around a curve with constant speed.
  - a. Does the velocity of the car change in this process? Explain.
  - b. Is the car accelerated? Explain.
- Q3. Two cars travel around the same curve, one at twice the speed of the other. After traveling the same distance, which car, if either, has experienced the larger change in velocity? Explain.
- Q4. A car travels the same distance at constant speed around two curves, one with twice the radius of curvature of the other. For which of these curves is the change in velocity of the car greater? Explain.

\*Q5. The centripetal acceleration depends on the square of the speed rather than just being proportional to the speed. Why does the speed enter twice? Explain.

Q6. A ball on the end of a string is whirled with constant speed in a counterclockwise, horizontal circle. At point A in the circle, the string breaks. Which of the curves sketched in the

diagram most accurately represents the path that the ball will take after the string breaks (as seen from above)? Explain.



**Q6 Diagram**

- Q7. Before the string breaks in question 6, is there a net force acting upon the ball? If so, what is its direction? Explain.
- Q8. For a ball being twirled in a horizontal circle at the end of a string, does the vertical component of the force exerted by the string produce the centripetal acceleration of the ball? Explain.
- Q9. A car travels around a flat (nonbanked) curve with constant speed.
  - a. Sketch a diagram showing all of the forces acting upon the car.
  - b. What is the direction of the net force acting upon the car? Explain.

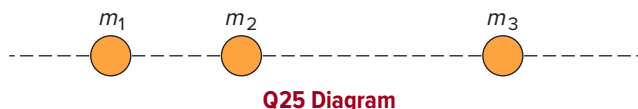
- Q10. Is there a maximum speed at which the car in question 9 will be able to negotiate the curve? If so, what factors determine this maximum speed? Explain.
- Q11. If a curve is banked, is it possible for a car to negotiate the curve even when the frictional force is zero due to very slick ice? Explain.
- \*Q12. If a ball is whirled in a vertical circle with constant speed, at what point in the circle, if any, is the tension in the string the greatest? Explain. (Hint: Compare this situation to the Ferris wheel described in section 5.2.)
- Q13. Sketch the forces acting upon a rider on a Ferris wheel when the rider is at the top of the cycle, labeling each force clearly. Which force is largest at this point, and what is the direction of the net force? Explain.
- Q14. Which safety measure, seat belts or air bags, offers the most protection in head-on collisions? Explain. (See everyday phenomenon box 5.1.)
- Q15. In a head-on collision between two vehicles, is there a force that propels a driver forward toward the windshield? Explain. (See everyday phenomenon box 5.1.)
- Q16. If a car is equipped with air bags, should it be necessary to also wear seat belts? Explain. (See everyday phenomenon box 5.1.)
- \*Q17. In what way did the heliocentric view of the solar system proposed by Copernicus provide a simpler explanation of planetary motion than the geocentric view of Ptolemy? Explain.
- Q18. Did Ptolemy's view of the solar system require motion of the Earth, rotational or otherwise? Explain.
- \*Q19. Heliocentric models of the solar system (Copernican or Keplerian) require that the Earth rotate on its axis, producing surface speeds of roughly 1000 MPH. If this is the case, why do we not feel this tremendous speed? Explain.
- Q20. How did Kepler's view of the solar system differ from that of Copernicus? Explain.
- Q21. Consider the method of drawing an ellipse pictured in figure 5.15. How would we modify this process to make the ellipse into a circle, which is a special case of an ellipse? Explain.
- Q22. Does a planet moving in an elliptical orbit about the sun move fastest when it is farthest from the sun or when it is nearest to the sun? Explain by referring to one of Kepler's laws.
- Q23. Does the sun exert a larger force on the Earth than that exerted on the sun by the Earth? Explain.
- Q24. Is there a net force acting on the planet Earth? Explain.

## Exercises

For the exercises in this chapter (and subsequent chapters), use the more accurate value of  $g = 9.8 \text{ m/s}^2$  for the acceleration due to gravity.

- E1. A ball is traveling at a constant speed of 4 m/s in a circle with a radius of 0.8 m. What is the centripetal acceleration of the ball?

- Q25. Three equal masses are located as shown in the diagram. What is the direction of the net force acting upon  $m_2$ ? Explain.



- Q26. Two masses are separated by a distance  $r$ . If this distance is doubled, is the force of interaction between the two masses doubled, halved, or changed by some other amount? Explain.
- Q27. A painter depicts a portion of the night sky as shown in the diagram below, showing the stars and a crescent moon. Is this view possible? Explain.



- Q28. At what times during the day or night would you expect the new moon to rise and set? Explain.
- Q29. At what times of the day or night does the half-moon rise or set? Explain.
- Q30. Are we normally able to see the new moon? Explain.
- Q31. During what phase of the moon can a solar eclipse occur? Explain.
- \*Q32. A synchronous satellite is one that does not move relative to the surface of the Earth; it is always above the same location. Why does such a satellite not just fall straight down to the Earth? Explain.
- Q33. Is Kepler's third law valid for artificial satellites orbiting about the Earth? Explain.
- Q34. Since the Earth rotates on its axis once every 24 hours, why don't high tides occur exactly twice every 24 hours? Explain.
- Q35. Why is there a high tide rather than a low tide when the moon is on the opposite side of the Earth from the ocean and the gravitational pull of the moon on the water is the weakest? Explain. (See everyday phenomenon box 5.2.)
- Q36. Would tides exist if the gravitational force did not depend on the distance between objects? Explain. (See everyday phenomenon box 5.2.)

- E2. A car rounds a curve with a radius of 40 m at a speed of 18 m/s. What is the centripetal acceleration of the car?
- E3. A ball traveling in a circle with a constant speed of 6 m/s has a centripetal acceleration of  $20 \text{ m/s}^2$ . What is the radius of the circle?



- E4. How much larger is the required centripetal acceleration for a car rounding a curve at 60 MPH than for one rounding the same curve at 20 MPH?
- E5. A 0.35-kg ball moving in a circle at the end of a string has a centripetal acceleration of  $5 \text{ m/s}^2$ . What is the magnitude of the centripetal force exerted by the string on the ball to produce this acceleration?
- E6. A car with a mass of 1500 kg is moving around a curve with a radius of 45 m at a constant speed of 18 m/s (about 40 MPH).
- What is the centripetal acceleration of the car?
  - What is the magnitude of the force required to produce this centripetal acceleration?
- E7. A car with a mass of 1300 kg travels around a banked curve with a constant speed of 20 m/s (about 45 MPH). The radius of curvature of the curve is 35 m.
- What is the centripetal acceleration of the car?
  - What is the magnitude of the horizontal component of the normal force that would be required to produce this centripetal acceleration in the absence of any friction?
- E8. A Ferris wheel at a carnival has a radius of 8 m and turns so that the speed of the riders is 4.5 m/s.
- What is the magnitude of the centripetal acceleration of the riders?
  - What is the magnitude of the net force required to produce this centripetal acceleration for a rider with a mass of 75 kg?
- E9. What is the ratio of the Earth's period of rotation about its own axis to the Earth's orbital period about the sun?
- E10. Dylan has a weight of 800 N (about 180 lb) when he is standing on the surface of the Earth. What would his weight (the gravitational force due to the Earth) be if he tripled his distance from the center of the Earth by flying in a spacecraft?
- E11. Two masses are attracted by a gravitational force of 9.6 N. What will the force of attraction be if the distance between the two masses is quadrupled?
- E12. Two 700-kg (1543-lb) masses are separated by a distance of 0.45 m. Using Newton's law of gravitation, find the magnitude of the gravitational force exerted by one mass on the other.
- E13. Two masses are attracted by a gravitational force of 0.28 N. What will the force of attraction be if the distance between these two masses is halved?
- E14. The acceleration of gravity at the surface of the moon is approximately one-sixth that at the surface of the Earth ( $9.8 \text{ m/s}^2$ ). What is the weight of an astronaut standing on the moon whose weight on Earth is 270 lb?
- E15. The acceleration of gravity on the surface of Jupiter is approximately  $25 \text{ m/s}^2$ . What is the weight on Jupiter of a woman whose weight on Earth is 150 lb?
- E16. The time separating high tides is 12 hours and 25 minutes. If high tide occurs at 1:10 P.M. on one afternoon,
- At what time will high tide occur the next afternoon?
  - When would you expect low tides to occur the next day?

## Synthesis Problems

For the synthesis problems in this chapter (and subsequent chapters), use the more accurate value of  $g = 9.8 \text{ m/s}^2$  for the acceleration due to gravity.

- SP1. A 0.25-kg ball is twirled at the end of a string in a horizontal circle with a radius of 0.45 m. The ball travels with a constant speed of 3.0 m/s.
- What is the centripetal acceleration of the ball?
  - What is the magnitude of the horizontal component of the tension in the string required to produce this centripetal acceleration?
  - What is the magnitude of the vertical component of the tension required to support the weight of the ball?
  - Draw to scale a vector diagram showing these two components of the tension and estimate the magnitude of the total tension from your diagram. (See appendix C.)
- SP2. A Ferris wheel with a radius of 15 m makes one complete rotation every 12 seconds.
- Using the fact that the distance traveled by a rider in one rotation is  $2\pi r$ , the circumference of the wheel, find the speed with which the riders are moving.
  - What is the magnitude of their centripetal acceleration?
  - For a rider with a mass of 50 kg, what is the magnitude of the centripetal force required to keep that rider moving in a circle? Is the weight of the rider large enough to provide this centripetal force at the top of the cycle?
  - What is the magnitude of the normal force exerted by the seat on the rider at the top of the cycle?
- SP3. A car with a mass of 1100 kg is traveling around a curve with a radius of 50 m at a constant speed of 25 m/s (56 MPH). The curve is banked at an angle of  $12^\circ$ .
- What is the magnitude of the centripetal acceleration of the car?
  - What is the magnitude of the centripetal force required to produce this acceleration?
  - What is the magnitude of the vertical component of the normal force acting upon the car to counter the weight of the car?
  - Draw a diagram of the car (as in fig. 5.8) on the banked curve. Draw to scale the vertical component of the normal force. Using this diagram, find the magnitude of the total normal force, which is perpendicular to the surface of the road.
  - Using your diagram, estimate the magnitude of the horizontal component of the normal force. Is this component sufficient to provide the centripetal force?
- SP4. Assume that a passenger in a rollover accident must turn through a radius of 2.8 m to remain in the seat of the vehicle. Assume also that the vehicle makes a complete turn in 0.9 second.
- Using the fact that the circumference of a circle is  $2\pi r$ , what is the speed of the passenger?

- b. What is the centripetal acceleration? How does it compare to the acceleration due to gravity?
- c. If the passenger has a mass of 75 kg, what is the centripetal force required to produce this acceleration? How does it compare to the passenger's weight?
- SP5. The sun's mass is  $1.99 \times 10^{30}$  kg, the Earth's mass is  $5.98 \times 10^{24}$  kg, and the moon's mass is  $7.36 \times 10^{22}$  kg. The average distance between the moon and the Earth is  $3.82 \times 10^8$  m, and the average distance between the Earth and the sun is  $1.50 \times 10^{11}$  m.
- Using Newton's law of gravitation, find the average force exerted on the Earth by the sun.
  - Find the average force exerted on the Earth by the moon.
  - What is the ratio of the force exerted on the Earth by the sun to that exerted by the moon? Will the moon have much of an impact on the Earth's orbit about the sun?
- d. Using the distance between the Earth and the sun as the average distance between the moon and the sun, find the average force exerted on the moon by the sun. Will the sun have much impact on the orbit of the moon about the Earth?
- SP6. The period of the moon's orbit about the Earth is 27.3 days, but the average time between full moons is approximately 29.3 days. The difference is due to the motion of the Earth about the sun.
- Through what fraction of its total orbital period does the Earth move in one period of the moon's orbit?
  - Draw a sketch of the sun, the Earth, and the moon with the moon in the full moon condition. Then, sketch the position the moon will be in 27.3 days later, when the Earth is in its new position. If the moon is in the same position relative to Earth as it was 27.3 days earlier, is this a full moon?
  - How much farther would the moon have to go to reach the full moon condition? Show that this represents approximately an extra 2 days.

## Home Experiments and Observations

- HE1. Tape a string half a meter or so in length securely to a small rubber ball. Practice whirling the ball in both horizontal and vertical circles and make these observations:
- For horizontal motion of the ball, how does the angle that the string makes with the horizontal vary with the speed of the ball?
  - If you let go of the string at a certain point in the circle, what path does the ball follow after release?
  - Can you feel differences in tension in the string for different speeds of the ball? How does the tension vary with speed?
  - For a vertical circle, how does the tension in the string vary for different points in the circle? Is it greater at the bottom than at the top when the ball moves with constant speed?
- HE2. Tie a small paper cup to a string, attaching it at two points near the rim, as shown in the diagram. Place a marble or other small object in the cup.
- Whirl the cup in a horizontal circle. Does the marble stay in the cup? (Be careful! A flying marble can be dangerous.)
  - Whirl the cup in a vertical circle. Does the marble stay in the cup? What keeps the marble in the cup at the top of the circle?
  - Try slowing the cup down. Does the marble stay in the cup?
  - If you are brave, try replacing the marble with water. Under what conditions does the water stay in the cup?
- HE3. Observe the position and phase of the moon on several days in succession and at regularly chosen times during the day and evening. (It is probably best to choose a point near the first quarter of the moon's cycle, when the moon is visible in the afternoon and evening.)
- Sketch the shape of the moon on each successive day. Does this shape change for different times in the same day?
  - Can you devise a method for accurately noting changes in the position of the moon at a set time—say, 10 P.M.—on successive days? A fixed sighting point, a meter stick, and a protractor may be useful. Describe your technique.
  - By how much does the position of the moon change from one day to the next at your regular chosen time?
- HE4. Consult your instructor or other sources to find out what planets are observable in the evening during the current month. Venus, Jupiter, and Mars are usually the best candidates.
- Locate the planet visually and observe it with binoculars if possible. How does the planet differ in appearance from nearby stars?
  - Sketch the position of the planet relative to nearby stars for several nights. How does this position change?



HE2 Diagram



# CHAPTER 6

Richard Megna/Fundamental Photographs, NYC

## Energy and Oscillations

---

### Chapter Overview

We usually approach energy by first considering how it is added to a system. This involves the concept of work, which has a specialized meaning in physics. If a force does work on a system, the energy of the system increases. Work is a means of transferring energy.

We begin by defining work and showing how to find it in simple cases. In different circumstances, work done on a system increases either the kinetic energy or the potential energy of the system. Finally, we tie these ideas together by introducing the principle of conservation of energy and applying it to practical situations, including oscillations.

### Chapter Outline

- 1 Simple machines, work, and power.** What is a simple machine? How does the idea of work help us to understand the operation of simple machines? How do physicists define work, and how is work related to power?
- 2 Kinetic energy.** What is kinetic energy? When and how does work change the kinetic energy of an object?
- 3 Potential energy.** What is potential energy? When and how does work change the potential energy of an object?
- 4 Conservation of energy.** What is the total energy of a system, and when is it conserved? How can we use these ideas to explain the motion of a pendulum and other phenomena?
- 5 Springs and simple harmonic motion.** How is the motion of a mass on a spring like a pendulum? What is simple harmonic motion?

**H**ave you ever watched a ball on the end of a string swing back and forth? A pendant on the end of a chain, a swing in the park, and the pendulum on a grandfather clock (fig. 6.1) all display the same hypnotic motion. Galileo (it is said) amused himself during boring sermons in church by watching the chandeliers sway slowly back and forth at the end of their chains.

What intrigued Galileo was the way a pendulum always seems to return to the same position at the end of each swing. It may fall a little short of the earlier position in successive swings, but the motion goes on for a long time before coming to a complete stop. On the other hand, the velocity is continually changing, from zero at the end points of the swing to a maximum at the low point in the path. How can the pendulum go through such changes in velocity and yet always return to its starting point?

Evidently, something is being saved, or *conserved*. The quantity that remains constant (and is conserved) turns out to be what we now call *energy*. Energy did not play a role in Newton's theory of mechanics. It was not until the nineteenth century that energy and energy transformations were elevated to the central position that they now hold in our understanding of the physical world.

The motion of a pendulum and other types of oscillation can be understood using the principle of conservation of mechanical energy. The potential energy that the pendulum has at its end points is converted to kinetic energy at the low point—and then back to potential energy. What is energy, though, and how does it get into the system in the first place?



**Figure 6.1** A weight swinging at the end of a bar. Why does it return to approximately the same point after each swing?

*Jonnie Miles/Getty Images*

Why does energy now play a central role in physics and all of science?

Energy is the basic currency of the physical world. To spend energy wisely, we must understand it. That understanding begins with the concept of *work*.

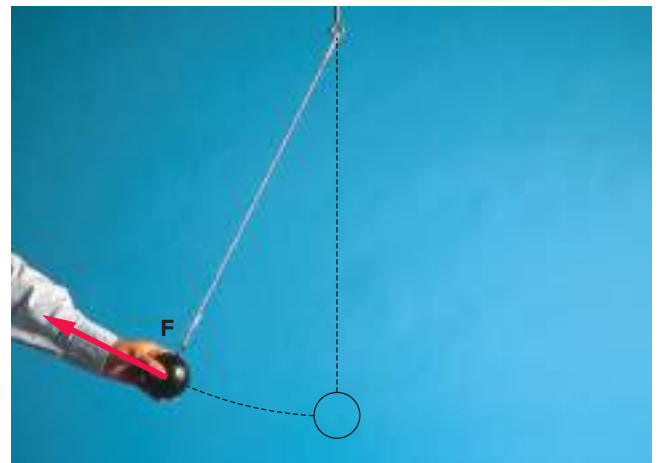
## 6.1 Simple Machines, Work, and Power

If you make a pendulum by fastening a ball to the end of a string (fig. 6.2), what do you do to start it swinging? In other words, how do you get energy into the system? Usually, you would start by pulling the ball away from the center position directly below the point from which the string is suspended. To do so, you must apply a force to the ball with your hand and move the ball some distance.

To a physicist, applying a force to move an object some distance involves doing work, even though the actual exertion may be slight. Doing work on a system increases the energy of the system, and this energy can then be used in the motion of the pendulum. How do we define work, though, and how can simple machines demonstrate the usefulness of the idea?

### What are simple machines?

An early application of work was the analysis of the devices, such as levers, pulley systems, and inclined planes, that we call *simple machines*. A **simple machine** is any mechanical device that multiplies the effect of an applied force. A lever is one example of a simple machine. By applying a small

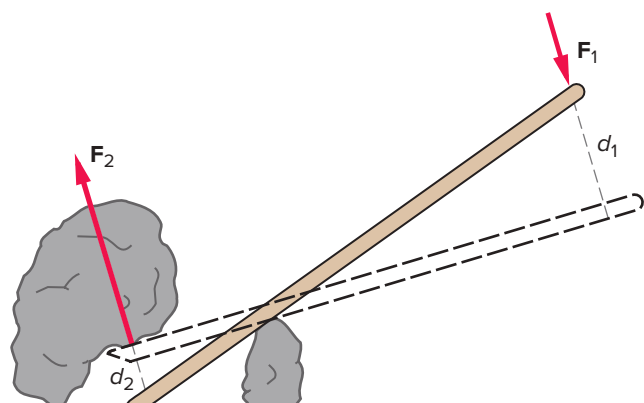


**Figure 6.2** The force applied does work to move the ball from its original position directly below the point of suspension.

*James Ballard/McGraw-Hill Education*

force at one end of a lever, a larger force can be exerted on the rock at the opposite end (fig. 6.3).

What price do you pay for this multiplying effect of the applied force? To move the rock a small distance, the other end of the lever must move through a larger distance.



**Figure 6.3** A lever is used to lift a rock. A small force  $F_1$  generates a larger force  $F_2$  to lift the rock, but  $F_1$  acts through a larger distance  $d_1$  than does  $F_2$ .

Generally, with simple machines, we get by with a small force if we are willing to apply that force over a large distance. The output force at the other end may be large, but it acts only over a short distance.

The pulley system shown in figure 6.4 is another simple machine that achieves a similar result. In this system, the tension in the rope pulls up on either side of the pulley supporting the weight. If the system is in equilibrium, the tension in the rope is only half the weight being lifted, because there are, in effect, two ropes pulling up on the pulley. But to lift the pulley and its load a certain height, the person must move the rope *twice* the distance the load moves. (Both rope segments on either side of the pulley must decrease in length by an amount equal to the increase in the height of the load.)

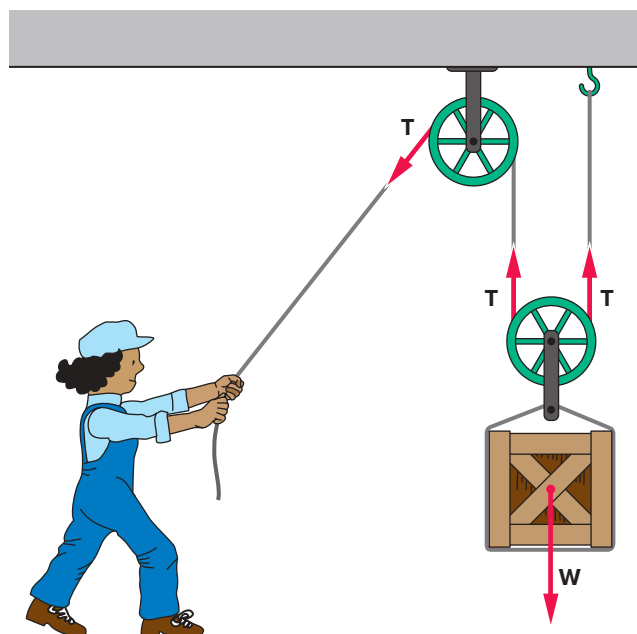
The net result of using the pulley system illustrated in figure 6.4 is that you can lift a weight a certain height by applying a force equal to only *half* the weight being lifted. However, you must pull the rope *twice* the distance the weight is lifted. This way, the product of the force and the distance moved will be the same for the input force applied by the person to the rope as for the output force exerted on the load. The quantity *force times distance* is thus conserved (if frictional losses are small). We call this product *work*, and the result for an ideal simple machine is

$$\text{work output} = \text{work input}$$

The ratio of the output force to the input force is called the **mechanical advantage** of the simple machine. For our pulley system, the mechanical advantage is 2. The output force that lifts the load is twice the input force exerted by the person pulling on the rope.

### How is work defined?

Our discussion of simple machines shows that the quantity force times distance has a special significance. Suppose



**Figure 6.4** A simple pulley system is used to lift a weight. The tension in the rope pulls up on either side of the lower pulley, so the tension is only half the size of the supported weight.

you apply a constant horizontal force to a heavy crate to move it across a concrete floor, as illustrated in figure 6.5. You would agree that you have done work to move the crate and that the farther you move it, the more work you will do.

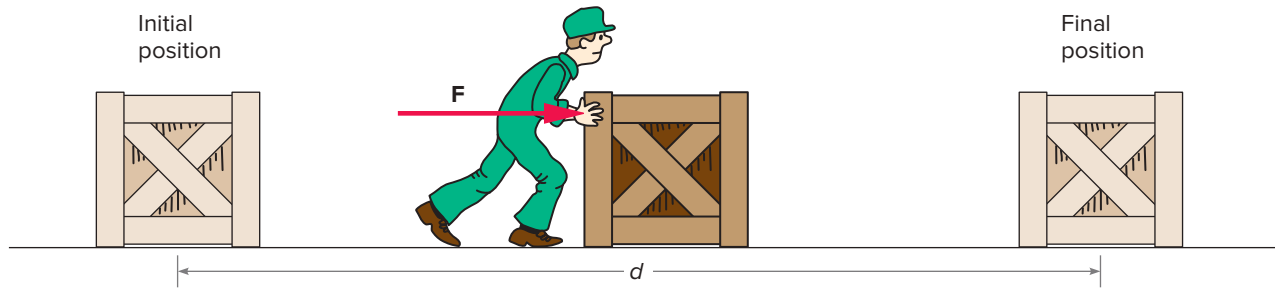
The amount of work that you do also depends on how hard you have to push to keep the crate moving. These are the basic ideas that we use in defining work: Work depends on both the *strength* of the applied force and the *distance* that the crate is moved. If the force and the distance moved are in the same direction, then **work** is the applied force multiplied by the distance that the crate moves under the influence of this force, or

$$\text{work} = \text{force} \times \text{distance}$$

$$W = Fd$$

where  $W$  is the work and  $d$  is the distance moved. The units of work will be units of force multiplied by units of distance, or newton-meters (N·m) in the metric system. We call this unit a *joule* (J). The joule is the basic metric unit of energy ( $1 \text{ J} = 1 \text{ N}\cdot\text{m}$ ).

The first part of the sample exercise in example box 6.1 shows how we find the work done in a simple case. A horizontal force of 50 N is used to pull a crate a distance of 4 m, resulting in 200 J of work done on the crate by the applied force. In doing this work, we transfer 200 J of energy to the crate and its surroundings from the person applying the force. The person loses energy; the crate and its surroundings gain energy.



**Figure 6.5** A crate is moved a distance  $d$  across a concrete floor under the influence of a constant horizontal force  $F$ .

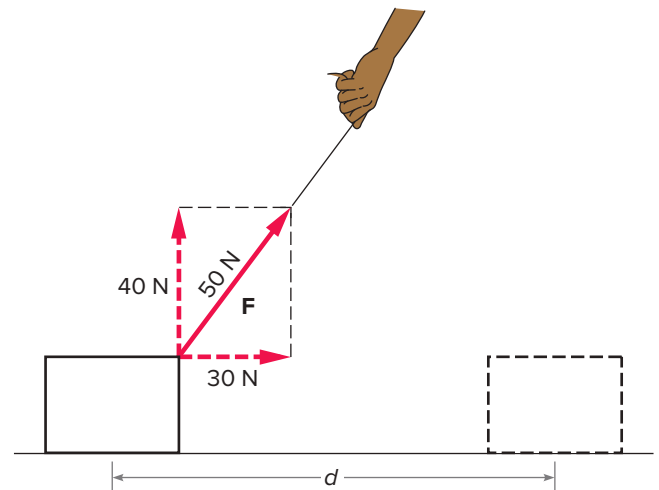
### Example Box 6.1

#### Sample Exercise: How Much Work?

A crate is pulled a distance of 4 m across the floor under the influence of a 50-N force applied by a rope to the crate. What is the work done on the crate by the 50-N force if

- The rope is horizontal, parallel to the floor?
- The rope pulls at an angle to the floor, so that the horizontal component of the 50-N force is 30 N (fig. 6.6)?

- |    |                      |                                 |
|----|----------------------|---------------------------------|
| a. | $F = 50 \text{ N}$   | $W = Fd$                        |
|    | $d = 4 \text{ m}$    | $= (50 \text{ N})(4 \text{ m})$ |
|    | $W = ?$              | $= \mathbf{200 \text{ J}}$      |
| b. | $F_h = 30 \text{ N}$ | $W = F_h d$                     |
|    | $d = 4 \text{ m}$    | $= (30 \text{ N})(4 \text{ m})$ |
|    | $W = ?$              | $= \mathbf{120 \text{ J}}$      |



**Figure 6.6** A rope is used to pull a box across the floor. Only the portion of the force that is parallel to the floor is used in computing the work.

### Does any force do work?

In our initial example, the force acting on the crate was in the same direction as the motion produced. What about other forces acting on the crate—do they do work? The normal force of the floor pushes upward on the crate, for example, but the normal force has no direct effect in producing the motion, because it is perpendicular to the direction of the motion. Forces *perpendicular* to the motion, such as the normal force or the gravitational force acting on the crate, *do no work* when the crate moves horizontally.

What if the force acting on an object is neither perpendicular nor parallel to the direction of the object's motion? In this case, we do not use the total force in computing work. Instead, we use only that portion or component of the force in the direction of the motion. This idea is illustrated in figure 6.6 and in the second part of example box 6.1.

In figure 6.6, the rope used to pull the crate is at an angle to the floor, so that part of the applied force is directed upward rather than parallel to the floor. The box

does not move in the direction of the force. Picture the force as having two components, one parallel to the floor and the other perpendicular to the floor. Only the component of the force in the direction of motion is used in computing the work. The component perpendicular to the motion does no work.

By taking direction into account, we can complete the definition of work:

The work done by a given force is the product of the component of the force along the line of motion of the object multiplied by the distance that the object moves under the influence of the force.

### How is power related to work?

When a car accelerates, energy is transferred from the fuel in the engine to the motion of the car. Work is done to move the car, but often we are more concerned with *how fast* this work is accomplished. The rate at which this work

can be done depends on the **power** of the engine. The shorter the time, the greater the power. Power can be defined as follows:

Power is the rate of doing work. It is found by dividing the amount of work done by the time required.

$$\text{power} = \frac{\text{work}}{\text{time}}$$

$$P = \frac{W}{t}$$

In the first part of the example in example box 6.1, we computed a work value of 200 J for moving a crate 4 m across the floor using a force of 50 N. If the crate is in motion for 10 seconds, the power is found by dividing 200 J by 10 seconds, yielding a power of 20 J/s. A joule per second (J/s) is called a *watt* (W), the metric unit of power. We use watts commonly in discussing electric power, but watts are also used more generally for any situation involving the rate of transfer of energy.

Another unit of power still used to describe the power of automobile engines is horsepower (hp). One horsepower is equal to 746 watts, or 0.746 kilowatt (kW). The day may come when we routinely compare the power of different engines in kilowatts rather than in horsepower, but we are not there yet. The relationship of horsepower to the typical horse is dubious, but comparing the iron horse to the flesh-and-blood kind still has a certain appeal.

Work is the applied force times the distance moved, provided that the force acts along the line of motion of the object. In simple machines, work output can be no greater than work input, even though the output force is larger than the input force. Power is the rate of doing work: The faster the work is done, the greater the power. Doing work on an object increases the energy of the object or system, as in our initial example of pulling the pendulum bob away from its equilibrium position.

## 6.2 Kinetic Energy

Suppose that the force applied to move a crate is the only force acting on the crate in the direction of motion. What happens to the crate then? According to Newton's second law, the crate will accelerate, and its velocity will increase. Doing work on an object increases its energy. We call the energy associated with the motion of the object **kinetic energy**.

Because work involves the transfer of energy, the amount of kinetic energy gained by the crate should be equal to the

amount of work done. How can we define kinetic energy so that this is indeed the case? Work serves as the starting point.

### How do we define kinetic energy?

Imagine you are pushing a crate across the floor (fig. 6.5). If you place the crate on rollers with good bearings, the frictional forces may be small enough to be ignored. The force you apply will then accelerate the crate. If you knew the mass of the crate, you could find its acceleration from Newton's second law of motion.

As the crate gains speed, you will have to move faster to keep applying a constant force. As we have seen in chapter 2, an object moving with constant acceleration travels a distance proportional to the square of the final speed. The work done is therefore also proportional to the square of the speed.

Because the work done should equal the increase in kinetic energy, the kinetic energy must increase with the square of the speed. If the crate begins from rest, the exact relationship turns out to be

$$\text{Work done} = \text{change in kinetic energy} = \frac{1}{2}mv^2$$

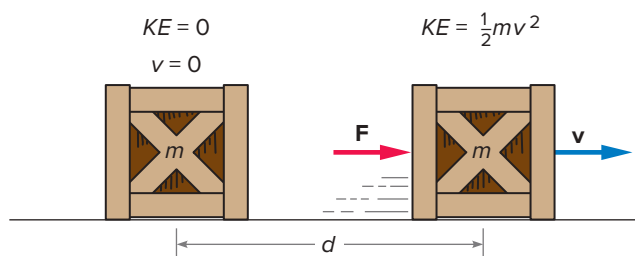
We often use the abbreviation *KE* to represent kinetic energy.

Kinetic energy is the energy of an object associated with its motion and is equal to one-half the mass of the object times the square of its speed.

$$KE = \frac{1}{2}mv^2$$

Figure 6.7 illustrates the process. If the crate is initially at rest, its kinetic energy is equal to zero. After being accelerated over a distance  $d$ , it has a final kinetic energy of  $\frac{1}{2}mv^2$ , which is equal to the work done on the crate. The work done is actually equal to the *change* in kinetic energy. If the crate was already moving when you began pushing, its increase in kinetic energy would equal the work done.

In example box 6.2, we highlight these ideas by calculating the energy gained by the crate in two different ways.



**Figure 6.7** The work done on an object by the net force acting on the object results in an increase in the object's kinetic energy.

## Example Box 6.2

### Sample Exercise: Work and Kinetic Energy

Starting from rest on a frictionless floor, you move a 120-kg crate by applying a net force of 96 N for a time of 4 s. This results in a final speed of 3.2 m/s after the crate moves a distance of 6.4 m (see synthesis problem 2). Find the following:

- The work done on the crate.
- The final kinetic energy of the crate.

$$\begin{aligned} \text{a. } F &= 96 \text{ N} & W &= Fd \\ d &= 6.4 \text{ m} & &= (96 \text{ N})(6.4 \text{ m}) \\ W &= ? & &= \mathbf{614 \text{ J}} \end{aligned}$$

$$\begin{aligned} \text{b. } m &= 120 \text{ kg} & KE &= \frac{1}{2}mv^2 \\ v &= 3.2 \text{ m/s} & &= \frac{1}{2}(120 \text{ kg})(3.2 \text{ m/s})^2 \\ KE &= ? & &= \mathbf{614 \text{ J}} \end{aligned}$$

In the first method, we use the definition of work. In the second, we use the definition of kinetic energy. We find that 614 J of work done on the crate results in an increase in kinetic energy of 614 J. It is no accident that these values are equal. Our definition of kinetic energy guarantees this to be true.

### What is negative work?

If work done on an object increases its kinetic energy, can work also decrease the energy of an object? Forces can decelerate objects, as well as accelerate them. Suppose, for example, that we apply the brakes to a rapidly moving car, and the car skids to a stop. Does the frictional force exerted by the road surface on the tires of the car do work?

When the car skids to a stop, it loses kinetic energy. A decrease in kinetic energy can be thought of as a negative change in kinetic energy. If the change in kinetic energy is negative, the work done on the car should also be negative.

Note that the frictional force exerted on the car acts in the *opposite* direction to the motion of the car, shown in figure 6.8. When this is so, we say that the work done on the car by the force is **negative work**, removing energy from the system (the car) rather than increasing its energy. For a frictional

force of magnitude  $f$ , the work done is  $W = -fd$ , if the car moves a distance  $d$  while decelerating. Because frictional forces always oppose the direction of motion, work done by friction is always negative.

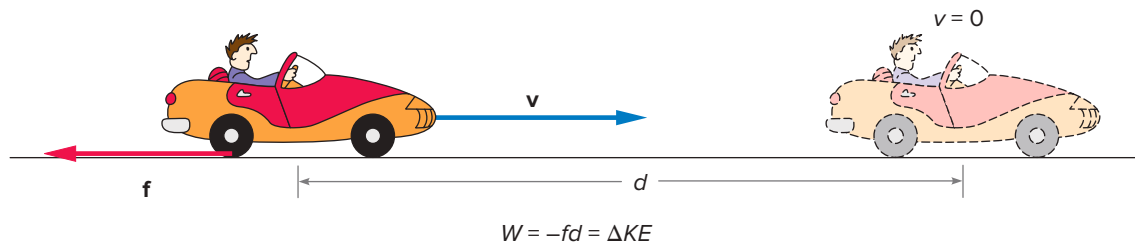
### Stopping distance for a moving car

The kinetic energy of the car is proportional not to the speed but rather to the *square* of the speed. If we double the speed, the kinetic energy *quadruples*. Four times as much work must be done to reach the doubled speed as was done to reach the original speed. Likewise, if we stop the car, four times as much energy must be removed.

A practical application is the stopping distances of cars traveling at different speeds. The amount of negative work required to stop the car is equal to the kinetic energy of the car before the brakes are applied. This amount of energy must be removed from the system. Because kinetic energy is proportional to the square of the speed, the work required (and the stopping distance) increases rapidly with the speed of the car. For example, the kinetic energy is four times as large for a car traveling at 60 MPH as for one traveling at 30 MPH. Doubling the speed requires four times as much negative work to remove the kinetic energy. The stopping distance at 60 MPH will be four times that required at 30 MPH, because the work done is proportional to the distance (assuming the frictional force is constant).

In fact, the frictional force varies with the speed of the car. If you look at the stopping distances in driver-training manuals, you will see that they do indeed increase rapidly with speed, although not exactly in proportion to the square of the speed. The more kinetic energy present initially, the more negative work is required to reduce this energy to zero, and the greater the stopping distance.

Kinetic energy is the energy associated with an object's motion, and it is equal to one-half the mass of the object times the square of its speed. The kinetic energy gained or lost by an object is equal to the work done by the net force accelerating or decelerating the object. Friction always acts as a force opposite to the direction of motion.



**Figure 6.8** Frictional forces exerted on the car's tires by the road surface do negative work in stopping the car, resulting in a decrease in kinetic energy.



## 6.3 Potential Energy

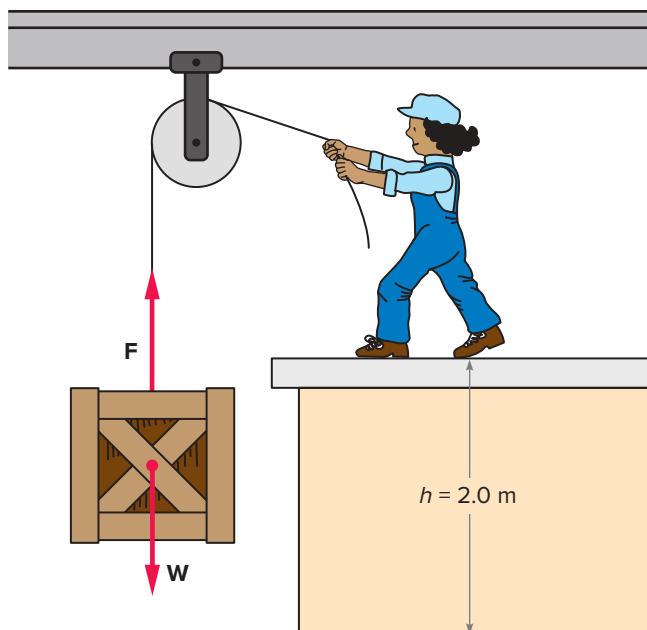
Suppose we lift a crate to a higher position on a loading dock, as in figure 6.9. Work is done in this process, but no kinetic energy is gained if the crate ends up just sitting on the dock. Has the energy of the crate increased? What happens to the work done by the lifting force?

Drawing back a bowstring or compressing a spring is similar. Work is done, but no kinetic energy is gained. Instead, the **potential energy** of the system increases. How does potential energy differ from kinetic energy?

### Gravitational potential energy

To lift the crate in figure 6.9, we need to apply a force that pulls or pushes upward on the crate. The applied force will not be the only force acting on the crate. The gravitational attraction of the Earth (the weight of the crate) pulls down on the crate. If we lift the crate with a force exactly equal to the force of gravity but opposite in direction, the net force acting on the crate will be zero, and the crate will not accelerate. We actually accelerate the crate a little bit at the start of the motion and decelerate it at the end of the motion, moving it with constant velocity during most of the motion.

The work done by the lifting force increases the **gravitational potential energy** of the crate. The lifting force and the gravitational force are equal in magnitude and opposite in direction, so the net force is zero and there is no acceleration. The lifting force does work by moving the



**Figure 6.9** A rope and pulley are used to lift a crate to a higher position on the loading dock, resulting in an increase in potential energy.

object against the gravitational pull. If we let go of the rope, the crate will accelerate downward, gaining kinetic energy.

How much gravitational potential energy is gained? The work done by the lifting force is equal to the size of the force times the distance moved. The applied force is equal to the weight of the crate  $mg$ . If the crate is moved a height  $h$ , the work done is  $mg$  times  $h$  or  $mgh$ . The gravitational potential energy is equal to the work done,

$$PE = mgh$$

where we use the abbreviation  $PE$  to represent potential energy.

The height  $h$  is the distance the crate moves above some reference level or position. In example box 6.3, we have chosen the original position of the crate on the ground to be our reference level. We usually choose the lowest point in the probable motion of the object as the reference level to avoid negative values of potential energy. The *changes* in potential energy are what is important, however, so the choice of reference level does not affect the physics of the situation.

### The essence of potential energy

The term *potential energy* implies storing energy to use later for other purposes. Certainly, this feature is present in the situation just described. The crate could be left indefinitely higher up on the loading dock. If we pushed it off the dock, though, it would rapidly gain kinetic energy as it fell. The kinetic energy, in turn, could be used to compress objects lying underneath, to drive pilings into the ground, or for other useful mayhem (fig. 6.10). Kinetic energy also has this feature, however, so storing energy is not what distinguishes potential energy.

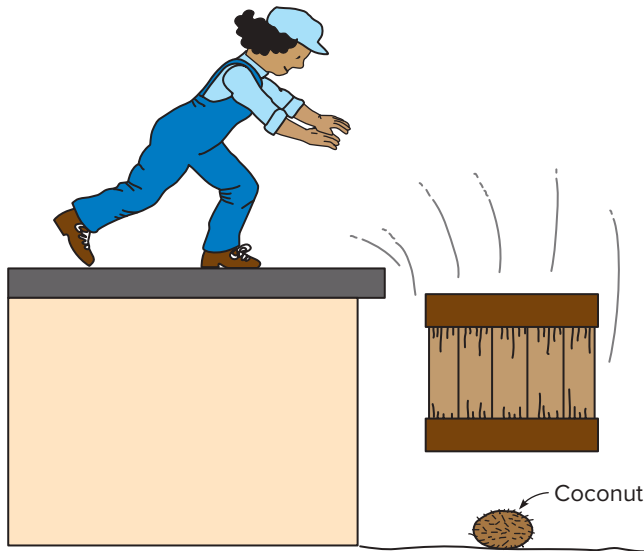
Potential energy involves *changing the position* of the object that is being acted on by a specific force. In the case of gravitational potential energy, that force is the

## Example Box 6.3

### Sample Exercise: Potential Energy

A crate with a mass of 100 kg is lifted onto a loading dock 2 m above ground level. How much potential energy has been gained?

$$\begin{aligned} m &= 100 \text{ kg} & PE &= mgh \\ h &= 2 \text{ m} & &= (100 \text{ kg})(9.8 \text{ m/s}^2)(2 \text{ m}) \\ g &= 9.8 \text{ m/s}^2 & &= (980 \text{ N})(2 \text{ m}) \\ & & &= \mathbf{1960 \text{ J}} \end{aligned}$$



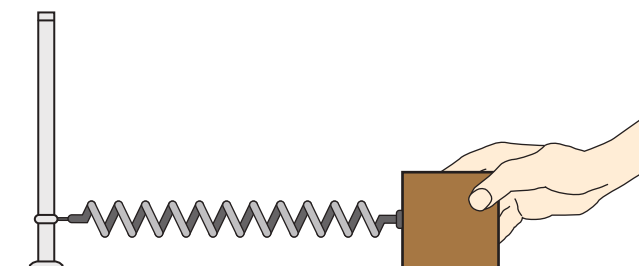
**Figure 6.10** The potential energy of the raised crate can be converted to kinetic energy and used for other purposes.

gravitational attraction of the Earth. The farther we move the object away from the Earth, the greater the gravitational potential energy. Other kinds of potential energy involve different forces.

### What is elastic potential energy?

What happens if we pull on a bowstring or stretch a spring? In these examples, work is done by an applied force against an opposing **elastic force**, a force that results from stretching or compressing an object. Imagine a spring attached to a post, as in figure 6.11, with a wooden block or similar object attached to the other end of the spring. If we pull the block from the original position where the spring was unstretched, the system gains *elastic potential energy*. If we let go, the block would fly back.

Because a force must be applied over some distance to move the block, work is done in pulling against the force



**Figure 6.11** A wooden block is attached to a spring tied to a fixed support at the opposite end. Stretching the spring increases the elastic potential energy of the system.

exerted by the spring. Most springs exert a force proportional to the distance the spring is stretched. The more the spring is stretched, the greater the force. This can be stated in an equation by defining the **spring constant**  $k$  that describes the stiffness of the spring. A stiff spring has a large spring constant. The force exerted by the spring is given by the spring constant multiplied by the distance stretched, or

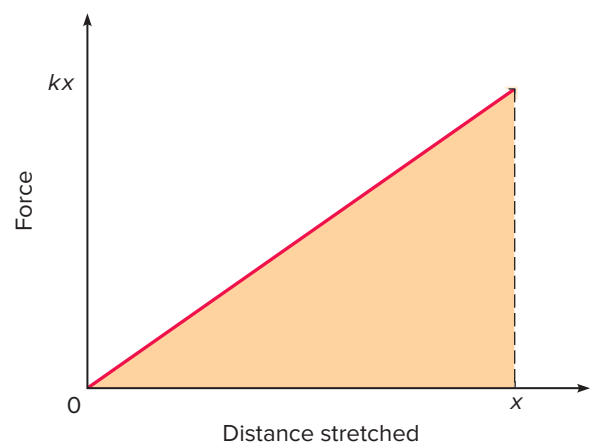
$$F = -kx$$

where  $x$  is the distance the spring is stretched, measured from its original, unstretched position. This is often called Hooke's Law, named after Robert Hooke (1635–1703). The minus sign indicates that the force exerted by the spring pulls back on the object as the object moves away from its equilibrium position. Thus, if the mass is moved to the right, the spring pulls back to the left. If the spring is compressed, it pushes back to the right.

How do we find the increase in potential energy of such a system? As before, we need to find the work done by the force involved in changing the position of the object. We want the block to move without acceleration so the net force acting on the block is zero. The applied force must be adjusted so it is always equal in magnitude but opposite in direction to the force exerted by the spring. This means the applied force must increase as the distance  $x$  increases (fig. 6.12).

The increase in **elastic potential energy** is equal to the work done by the average force needed to stretch the spring. Figure 6.12 suggests that the average force is one-half the magnitude of the final force  $kx$ . The work done is the average force  $\frac{1}{2}kx$  times the distance  $x$ , so

$$PE = \frac{1}{2}kx^2$$



**Figure 6.12** The applied force used to stretch the spring varies with the distance stretched, going from an initial value of zero to a final value of  $kx$ . Work done is equal to the shaded area under the force-versus-distance curve.

The potential energy of the stretched-spring system is one-half the spring constant times the square of the distance stretched. The same expression is valid when the spring is compressed. The distance  $x$  is then the distance the spring is compressed from its original, relaxed position.

The potential energy stored in the spring can be converted to other forms and put to various uses. If we let go of the block when the spring is either stretched or compressed, the block will gain kinetic energy. Cocking a bow and arrow, squeezing a rubber ball, and stretching a rubber band are all familiar examples in which we generate elastic potential energy similar to the spring.

### What are conservative forces?

Potential energy can result from work done against a variety of forces besides gravity and springs. Work done against frictional forces, however, does not result in an increase in the potential energy of the system. Instead, heat is generated, which either transfers energy out of the system or increases the internal energy of the system at the atomic level. As discussed in chapter 11, this internal energy cannot be completely recovered to do work on another object or system.

Forces such as gravity or elastic forces that lead to potential energy relationships are referred to as **conservative forces**. When work is done against conservative forces, the energy gained by the system is completely recoverable for use in other forms.

Potential energy associated with some conservative force (such as gravity or the spring force) is an object's energy by virtue of its position rather than the object's motion. We find the potential energy by computing the work done to move the object against the conservative force. The system is then poised to release that energy, converting it to kinetic energy or work done on some other system.

## 6.4 Conservation of Energy

The concepts of work, kinetic energy, and potential energy are now available to us. How can they help explain what is happening in systems like a pendulum?

*Conservation of energy* is the key. The total energy, the sum of the kinetic and potential energies, is a quantity that remains constant (is conserved) in many situations. We can describe the motion of a pendulum by tracking the energy transformations. What can this tell us about the system?

### Energy changes in the swing of a pendulum

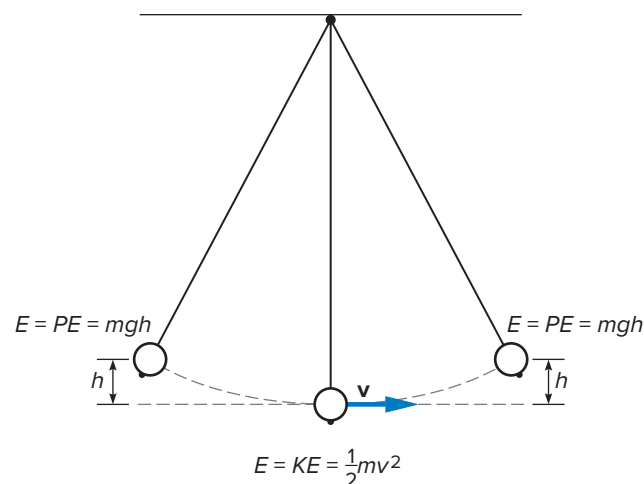
Imagine a pendulum consisting of a ball initially hanging motionless at the end of a string attached to a rigid support. You pull the ball to the side and release it to start it swinging. What happens to the energy of the system?

In the first step, work is done on the ball by your hand. The net effect of this work is to increase the potential energy of the ball, because the height of the ball above the ground increases as the ball is pulled to the side. The work done transfers energy from the person doing the pulling to the system consisting of the pendulum and the Earth. It becomes gravitational potential energy,  $PE = mgh$ , where  $h$  is the height of the ball above its initial position (fig. 6.13).

When you release the ball, this potential energy begins to change to kinetic energy as the ball begins its swing. At the bottom of the swing (the initial position of the ball when it was just hanging), the potential energy is zero, and the kinetic energy reaches its maximum value. The ball does not stop at the low point; its motion continues to a point opposite the release point. During this part of the swing, the kinetic energy decreases, and the potential energy increases until it reaches the point where the kinetic energy is zero and the potential energy is equal to its initial value before release. The ball then swings back, repeating the transformation of potential energy to kinetic energy and back to potential energy (fig. 6.13).

### What does it mean to say that energy is conserved?

As the pendulum swings, there is a continuing change of potential energy to kinetic energy and back again. The total mechanical energy of the system (the sum of the potential and kinetic energies) remains constant, because there is no work being done on the system to increase or decrease its energy. The swing of the pendulum demonstrates the principle of **conservation of energy**:



**Figure 6.13** Potential energy is converted to kinetic energy and then back to potential energy as the pendulum swings back and forth.

When only conservative forces are involved, the total mechanical energy of the system (the sum of its kinetic energy and potential energy) remains constant.

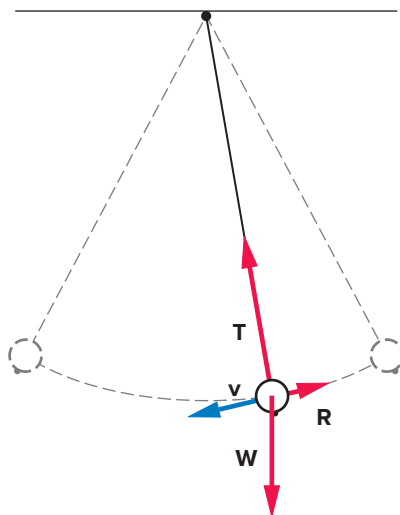
Work is pivotal. If no energy is added or removed by forces doing work, the total energy should not change. In symbols, this statement takes this form:

$$\text{If } W = 0, \quad E = PE + KE = \text{constant}$$

where  $E$  is the symbol commonly used to represent the total energy. A broader picture of the meaning of this very important principle is provided in everyday phenomenon box 6.1.

We applied conservation of energy in describing the motion of the pendulum. Some points deserve close attention: For example, why do we *not* consider the work done by gravity on the pendulum? The answer is that the gravitational force becomes part of the system by including the gravitational potential energy of the ball in our description. Gravity is a conservative force already accounted for by potential energy.

What other forces act on the ball? The tension of the string acts in a direction perpendicular to the motion of the ball (fig. 6.14). This force does no work, because it has no component in the direction of the motion. The only other force that need concern us is air resistance. This force does negative work on the ball, slowly decreasing the total mechanical energy of the system. The total energy of the system is not completely constant in this situation. It would be constant only if air resistance were negligible. The air-resistive effects are often small, however, and can be ignored.



**Figure 6.14** Of the three forces acting on the ball, only the force of air resistance does work on the system to change its total energy. The tension does no work, and the work done by gravity is already included in the potential energy.

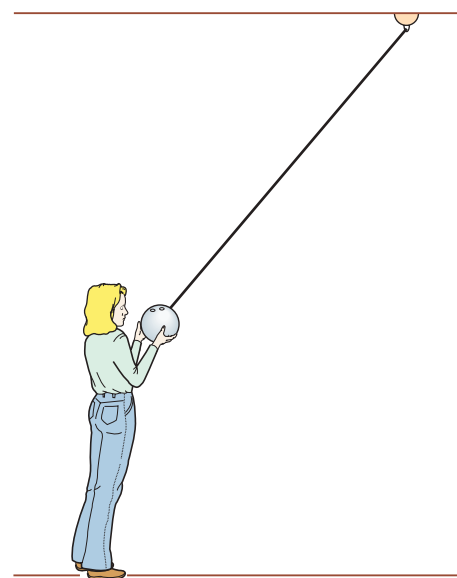
### Why do we use the concept of energy?

What are the advantages of using the principle of conservation of energy? Imagine trying to describe the motion of the pendulum by direct application of Newton's laws of motion. You would have to deal with forces that vary continually in direction and magnitude as the pendulum moves. A full description using Newton's laws is quite complex.

Using energy considerations, however, we can make predictions about the behavior of a system much more easily than by applying Newton's laws. To the extent that we can ignore frictional effects, for example, we can predict that the ball will reach the same height at either end of its swing. The kinetic energy is zero at the end points of the swing where the ball momentarily stops, and at these points, the total energy equals potential energy. If no energy has been lost, the potential energy has the same value it had at the point of release, which implies that the same height is reached ( $PE = mgh$ ).

A demonstration sometimes performed in physics lecture rooms using a bowling ball as the pendulum bob illustrates this idea dramatically. The bowling ball is suspended from a support near the ceiling, so that when pulled to one side, the ball is near the chin of the physics instructor. The instructor pulls the ball to this position, releases it to allow it to swing across the room, and stands without flinching as the ball returns and stops just a few inches from his or her chin (fig. 6.15). Not flinching requires some faith in the principle of conservation of energy! The success of this demonstration depends on the ball's not being given any initial velocity when released. But what happens if it is pushed?

We can also use the principle of conservation of energy to predict what the speed will be at any point in the swing. The speed is zero at the end points and has its maximum



**Figure 6.15** A bowling ball at the end of a cable suspended from the ceiling is released and allowed to swing across the room and back, stopping just in time.

## Everyday Phenomenon

## Box 6.1

**Conservation of Energy**

**The Situation.** Mark Shoemaker had just come out of a physics lecture on the conservation of energy, and he was confused. His instructor had noted that the principle of conservation of energy in its most general form implies that energy can be neither created nor destroyed—it is always conserved.

On the other hand, Mark had been following news items regarding the need to conserve energy. If energy is always conserved, what is the problem that news commentators and environmentalists are harping on? Don't they understand physics?

**The Analysis.** When people talk about conserving energy in the context of everyday energy use, the term *conservation of energy* has a different meaning than that involved in the physics principle. Understanding these distinctions is critical to understanding the issues involving energy and the environment that have been hot topics in recent years.

The principle of conservation of energy stated in this section is limited to mechanical energy, the sum of the potential and kinetic energies of a mechanical system. In chapters 10 and 11, we will see that heat is also a form of energy and must be included in a more general statement of the conservation principle. Later, in chapter 20, we will find that even mass must be considered a form of energy. In this most general context, energy is always conserved.

However, not all forms of energy have equal value in our daily lives. To take an example, oil is an important energy resource. The energy stored in oil is a form of potential energy involving the electric forces that bind atoms together in molecules. When we use oil, we are converting this potential energy to other forms of energy, depending on the application.

To release this potential energy, we usually burn the oil. Burning generates heat, which is a form of energy. At high temperatures, this heat can be very useful for running heat engines of various kinds (discussed in chapter 11). The common gasoline engine in our cars is a heat engine, as are the diesel engines that power trucks and trains and the jet turbines that power airplanes. These engines transform some energy in the form of heat to kinetic energy for cars, trains, boats, and airplanes.

But what happens, ultimately, to the kinetic energy associated with the moving vehicles? Eventually, it is transformed to lower-temperature heat due to frictional effects in the engine and the tires and air resistance. The energy has not disappeared—it warms up the surroundings. However, it is now in a form that is much less useful than the original potential energy stored in the fuel. Heat at temperatures near those of the surroundings is sometimes called low-grade heat—its uses are limited to heating our homes or similar applications.

So what are we conserving when we talk about energy conservation in our daily lives? We are conserving high-value forms of energy by using them more wisely and, as much as possible, preventing

them from being converted to less useful forms of energy. We are also limiting the environmental effects associated with burning oil and other fuels such as natural gas or coal. From the standpoint of physics, though, the energy itself is conserved in all situations.

If you have a choice of commuting to work or school by walking, riding a bicycle, or driving a fuel-efficient car as opposed to driving a large car or sports utility vehicle (SUV), your choice should be clear. By walking or riding a bicycle, as pictured in the photograph, you convert some energy obtained from the food you eat to low-grade heat, but much less high-value energy is converted than if you are driving an SUV or car. And, of course, your impact on the environment is much smaller when you are walking or riding a bicycle.

Later chapters in this book deal with many aspects of energy use. The laws of thermodynamics, discussed in chapters 10 and 11, are particularly important to understanding energy issues. Solar energy, geothermal power, and other methods of generating electricity are discussed in chapter 11. Chapter 13 addresses household electrical energy uses, while chapter 14 deals with electrical power generation, and chapter 19 discusses nuclear power.

The physics and economics of wise energy use are critical issues. To be involved in these debates, you should understand what energy conservation is all about. Energy can be neither created nor destroyed, but the ways in which it is transformed from one form to another are extremely important to the use of energy resources and to the environment.



Is energy conserved for all these commuters?  
PhotoAlto

value at the low point of the swing. If we place our reference level for measuring potential energy at this low point, the potential energy will be zero there, because the height is zero. All of the initial potential energy has been converted to kinetic energy. Knowing the kinetic energy at the low point allows us to compute the speed, as shown in example box 6.4.

We could find the speed at any other point in the swing by setting the total energy at any point equal to the initial energy. Different values of the height  $h$  above the low point yield different values of the potential energy. The remaining energy must be kinetic energy. The system has only so much energy, either potential or kinetic energy, or some of both, but it cannot exceed the initial value.

### How is energy analysis like accounting?

Both a roller coaster and a sled on a hill illustrate the principle of conservation of energy. Conservation of energy can be used to make predictions about the speed of the sled or roller coaster that would be hard to make by direct application of Newton's laws. An energy accounting provides a better overview. The pole-vaulting example in everyday phenomenon box 6.2 can also be analyzed in this way.

Consider the sled on the hill in figure 6.16. A parent pulls the sled to the top of the hill, doing work on the sled and rider that increases their potential energy. At the top of the hill, the parent may do more work by giving the sled a push, providing it with some initial kinetic energy. The total work done by the parent is the energy input to the system and equals the sum of the potential and kinetic energies shown in table 6.1.

## Example Box 6.4

### Sample Exercise: The Swing of a Pendulum

A pendulum bob with a mass of 0.50 kg is released from a position in which the bob is 12 cm above the low point in its swing. What is the speed of the bob as it passes through the low point in its swing?

$m = 0.5 \text{ kg}$	The initial energy is
$h = 12 \text{ cm}$	$E = PE = mgh$
$v = ?$	$= (0.5 \text{ kg})(9.8 \text{ m/s}^2)(0.12 \text{ m})$
(at the low point)	$= 0.588 \text{ J}$

At the low point, the potential energy is zero, so

$$E = KE = 0.588 \text{ J}$$

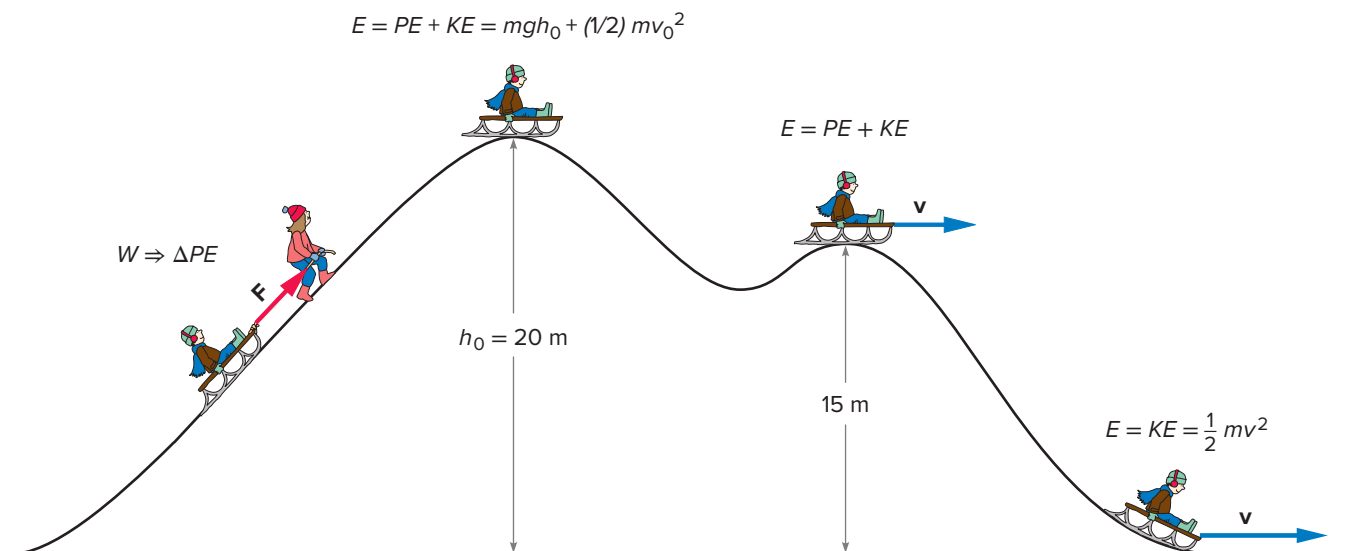
$$\frac{1}{2}mv^2 = 0.588 \text{ J}$$

Dividing both sides by  $\frac{1}{2}m$ ,

$$\begin{aligned} v^2 &= \frac{KE}{\frac{1}{2}m} \\ &= \frac{(0.588 \text{ J})}{\frac{1}{2}(0.5 \text{ kg})} \\ &= 2.35 \text{ m}^2/\text{s}^2 \end{aligned}$$

Taking the square root of both sides,

$$v = 1.53 \text{ m/s}$$



**Figure 6.16** Work done in pulling a sled up a hill produces an increase in potential energy of the sled and rider. This initial energy is then converted to kinetic energy as they slide down the hill.

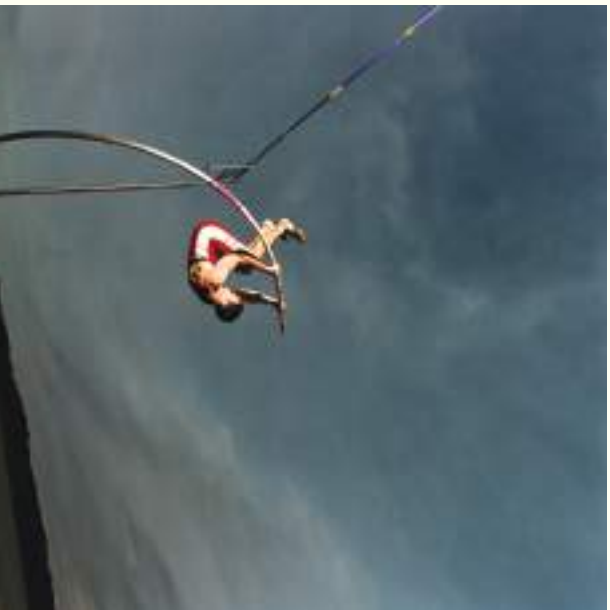
## Everyday Phenomenon

## Box 6.2

### Energy and the Pole Vault

**The Situation.** Ben Lopez goes out for track. He specializes in the pole vault and helps out sometimes with the sprint relays, where his speed can be used to good advantage. His coach, aware that Ben is also taking an introductory physics course, suggests that Ben try to understand the physics of the pole vault. What factors determine the height reached? How can he optimize these factors?

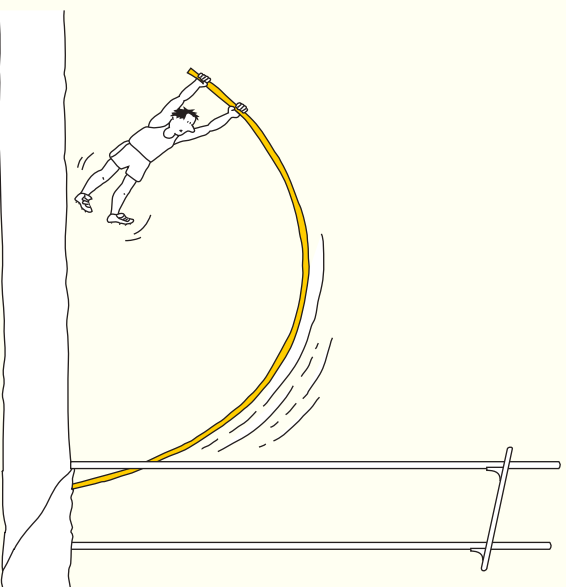
The coach knows that energy considerations are important in the pole vault. What types of energy transformation are involved? Could understanding these effects help Ben's performance?



A pole-vaulter on the way up. What energy transformations are taking place?  
*Patrick Gardino/Getty Images*

**The Analysis.** It was not difficult for Ben to describe the energy transformations that take place in the pole vault: The vaulter begins by running down a path to the vaulting standard and pit. During this phase, he is accelerating and increasing his kinetic energy at the expense of chemical energy stored in his muscles. When he reaches the standard, he plants the end of the pole in a notch in the ground. At this point, some of his kinetic energy is stored in the elastic potential energy of the bent pole, which acts as a spring. The rest is converted to gravitational potential energy as he begins to rise over the standard.

Near the top of the vault, the elastic potential energy in the bent pole converts to gravitational potential energy as the pole straightens out. The vaulter does some additional work with his



The flexibility of the pole and the point at which the vaulter grasps the pole are important to the success of the vault.

arm and upper-body muscles to provide an extra boost. At the very top of his flight, his kinetic energy should be zero, with only a minimal horizontal velocity left to carry him over the standard. Too large a kinetic energy at this point would indicate that he had not optimized his jump by converting as much energy as possible into gravitational potential energy.

What can Ben learn from his analysis? First is the importance of speed. The more kinetic energy he generates during his approach, the more energy is available for conversion to gravitational potential energy ( $mgh$ ), which will largely determine the height of his vault. Successful pole-vaulters are usually good sprinters.

The characteristics of the pole and Ben's grip on it are also important factors. If the pole is too stiff, or if he has gripped it too close to the bottom, he will experience a jarring impact in which little useful potential energy is stored in the pole, and some of his initial kinetic energy will be lost in the collision. If the pole is too limber, or if Ben's grip is too far from the bottom, it will not spring back soon enough to provide useful energy at the top of his vault.

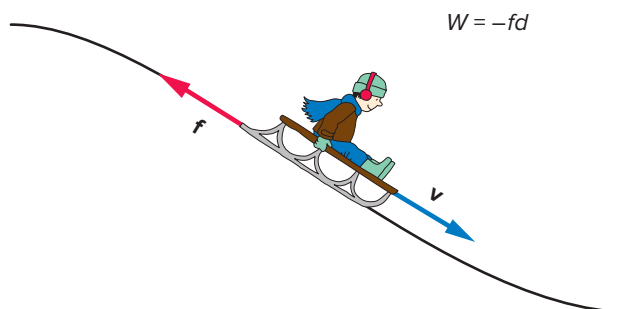
Finally, upper-body strength is important in clearing the standard. Good upper-body conditioning should improve Ben's pole vaulting. Timing and technique are also critical and can be improved only through practice. As far as his coach is concerned, that may be the most important message.

Table 6.1

Energy Balance Sheet for the Sled	
A parent pulls a sled and rider with a combined weight of 50 kg to the top of a hill 20 m high and then gives the sled a push, providing an initial velocity of 4 m/s. Frictional forces acting on the sled do 2000 J of negative work as the sled moves down the hill.	
<i>Energy input</i>	
Potential energy gained by work done in pulling sled up the hill:	
$PE = mgh = (50 \text{ kg})(9.8 \text{ m/s}^2)(20 \text{ m})$	9800 J
Kinetic energy gained by work done in pushing the sled at the top:	
$KE = \frac{1}{2}mv^2 = \frac{1}{2}(50 \text{ kg})(4 \text{ m/s})^2$	400 J
<b>Total initial energy:</b>	<b>10,200 J</b>
<i>Energy expenditures</i>	
Work done against friction as the sled slides down the hill:	
$W = -fd$	-2000 J
<b>Energy balance:</b>	<b>8200 J</b>

Where did this initial energy come from? It came from the body of the parent doing the pulling and pushing. Muscle groups were activated, releasing chemical potential energy stored in the body. That energy came from food, which in turn involved solar energy stored by plants. A parent who does not eat a good breakfast, or attempts too many trips up the hill, may not have enough energy to get to the top.

If the sled and rider slide down the hill with negligible friction and air resistance, energy is conserved, and the total energy at any point during the motion should equal the initial energy. It is more realistic to assume that there is some friction as the sled slides down the hill (fig. 6.17). Although it is difficult to predict the amount of work done against friction precisely, we can make an estimate if we know the total distance traveled and make some assumptions about the size of the average frictional force. In the energy accounting done in table 6.1, we assume that 2000 J of work has been



**Figure 6.17** The work done by frictional forces is negative, and it removes mechanical energy from the system.

done against friction by the time the sled reaches the bottom of the hill.

The work done against friction removes energy from the system and shows up as an expenditure on the account sheet. The energy balance at the bottom of the hill is 8200 J rather than 10,200 J. This will lead to a smaller, more realistic value for the speed of the sled and rider at the bottom of the hill than if we ignored friction. Although precise calculations are not always possible, energy accounting sets limits on what is likely and helps us understand the behavior of systems such as the sled on the hill.

Energy is the currency of the physical world; an understanding of energy accounting is relevant to both science and economics. Doing work on a system puts energy in the bank. Total energy is then conserved, provided that only conservative forces are at work. Many aspects of the motion of the system can be predicted from a careful energy accounting.

### Debatable Issue

Does the bicycle rider pictured in the photograph in everyday phenomena box 6.1 use any energy in his commute? If so, where does this energy come from, and how can we claim that he is conserving energy by commuting by bike?

## 6.5 Springs and Simple Harmonic Motion

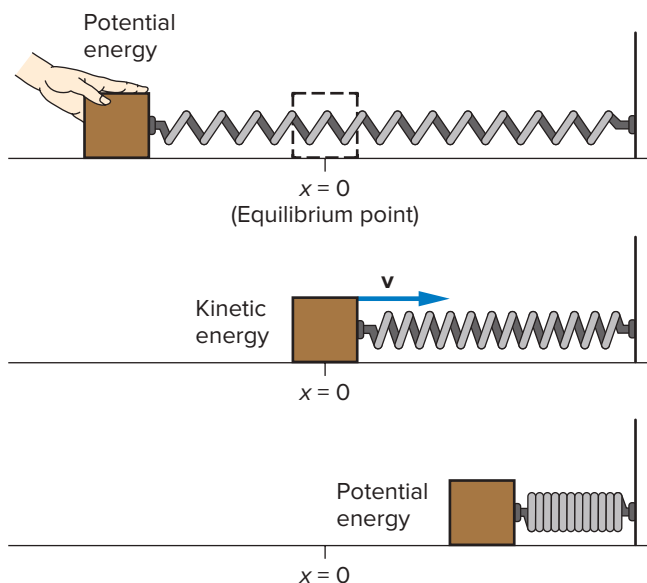
If conservation of energy explains the motion of a pendulum, what about other systems that oscillate? Many systems involve springs or elastic bands that move back and forth, with potential energy being converted to kinetic energy and then back to potential energy repeatedly. What do such systems have in common? What makes them tick?

A mass on the end of a spring is one of the simplest oscillating systems. This system, and the simple pendulum described in section 6.4, are examples of *simple harmonic motion*.

### Oscillation of a mass attached to a spring

If we attach a block to the end of a spring, as in figure 6.18, what happens when we pull it to one side of its equilibrium position? The equilibrium position is where the spring is neither stretched nor compressed. Doing work to pull the mass against the opposing force of the spring increases the potential energy of the spring-mass system. The potential energy in this case is elastic potential energy,  $\frac{1}{2}kx^2$ , rather than the gravitational potential energy associated with the pendulum. Increasing the potential energy of the mass on the spring is similar to cocking a bow and arrow or slingshot.





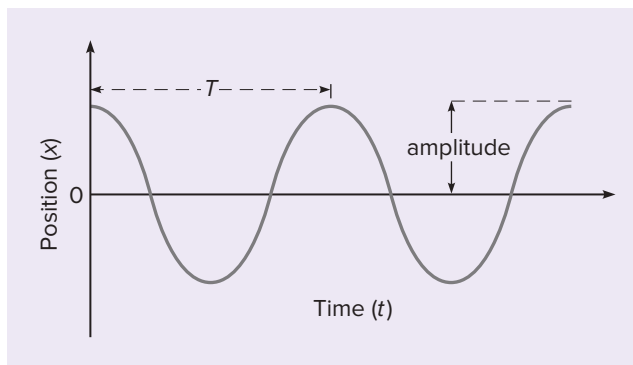
**Figure 6.18** Energy added by doing work to stretch the spring is then transformed back and forth between the potential energy of the spring and the kinetic energy of the mass.

Once the mass is released, potential energy is converted to kinetic energy. As for the pendulum, the motion of the mass carries it beyond the equilibrium position, and the spring is compressed, gaining potential energy again. When the kinetic energy is completely reconverted to potential energy, the mass stops and reverses, and the whole process repeats (fig. 6.18). The energy of the system changes continually from potential energy to kinetic energy and back again. If frictional effects can be ignored, the total energy of the system remains constant while the mass oscillates back and forth.

Using a video camera or other tracking techniques, it is possible to measure and plot the position of a pendulum bob or mass on a spring as it varies with time. If we plot the position of the mass against time, the resulting curve takes the form shown in figure 6.19. The mathematical functions that describe such curves are called “harmonic” functions, and the motion is called **simple harmonic motion**,\* a term probably borrowed from musical descriptions of sounds produced by vibrating strings, reeds, and air columns. (See chapter 15.)

The line at zero on the graph in figure 6.19 is the equilibrium position for the mass on a spring. Points above this line represent positions on one side of the equilibrium point, and those below the line represent positions on the other side. The motion starts at the point of release, where the distance of the mass from equilibrium is a maximum. As the mass moves toward the equilibrium position ( $x = 0$  on the graph), it gains speed, indicated by the increasing slope of the curve. (See section 2.4.) The object’s position changes most rapidly when it is near the equilibrium point, where the kinetic energy and speed are the greatest.

\*If you have studied trigonometry, you may know that the curve plotted in figure 6.19 is a cosine function. Sines and cosines are collectively referred to as harmonic functions.



**Figure 6.19** The horizontal position  $x$  of the mass on the spring is plotted against time as the mass moves back and forth. The resulting curve is a harmonic function.

As the mass passes through the equilibrium position, it starts to move away from equilibrium in the direction opposite to its initial position. The force exerted by the spring is now in the direction opposite to the velocity and is decelerating the mass. When the mass reaches the point farthest from its release point, the speed and kinetic energy are again zero, and the potential energy has returned to its maximum value. (See example box 6.5.) The slope of the curve is zero at this point, indicating that the mass is momentarily stopped (its velocity is zero). The mass continually gains or loses speed as it moves back and forth.

## Example Box 6.5

### Sample Exercise: Motion of a Mass on a Spring

A 500-g (0.50-kg) mass is undergoing simple harmonic motion at the end of a spring with a spring constant of 800 N/m. The motion takes place on a frictionless horizontal surface as pictured in figure 6.18. The speed of the mass is 12 m/s when it passes through the equilibrium point.

- What is the kinetic energy at the equilibrium point?
  - How far does the mass travel from the equilibrium point before it turns around?
- a.**  $m = 0.50 \text{ kg}$        $KE = \frac{1}{2}mv^2$   
 $v = 12 \text{ m/s}$        $KE = \frac{1}{2}(0.50 \text{ kg})(12 \text{ m/s})^2$   
 $KE = ?$        $KE = \mathbf{36 \text{ J}}$
- b.**  $x = ?$        $E = KE + PE = 36 \text{ J}$   
 (when  $v = 0$ )      but  $KE = 0$  at the turn-around point  
 so  $PE = \frac{1}{2}kx^2 = 36 \text{ J}$   
 $x^2 = \frac{2(36 \text{ J})}{k}$   
 $x^2 = \frac{72 \text{ J}}{800 \text{ N/m}}$   
 $x^2 = 0.09 \text{ m}^2$   
 $x = 0.30 \text{ m} = \mathbf{30 \text{ cm}}$

### What are the period and the frequency?

If you look at the graph in figure 6.19, you will notice that the curve repeats itself regularly. The **period**  $T$  is the repeat time, or the time taken for one complete cycle. It is usually measured in seconds. You can think of the period as the time between adjacent peaks or valleys on the curve. A slowly oscillating system has a long period, and a rapidly oscillating system has a short period.

Suppose the period of oscillation for a certain spring and mass is half a second. There are then two oscillations each second, which is the **frequency** of oscillation. The frequency  $f$  is the number of cycles per unit time, and it is found by taking the reciprocal of the period,  $f = 1/T$ . A rapidly oscillating system has a very short period and thus a high frequency. The unit commonly used for frequency is the *hertz*, which is defined as one cycle per second.

What determines the frequency of the spring-mass system? Intuitively, we expect a loose spring to have a low frequency of oscillation and a stiff spring to have a high frequency. This is indeed the case. The mass attached to the spring also has an effect. Larger masses offer greater resistance to a change in motion, producing lower frequencies.

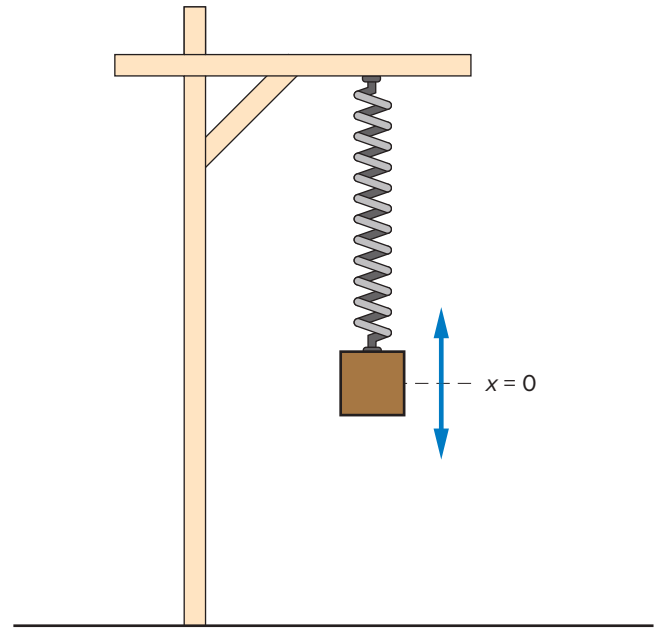
The period and frequency of oscillation of a pendulum depend primarily on its length, measured from the pivot point to the center of the bob. To measure the period, you usually measure the time required for several complete swings and then divide by the number of swings to get the time for one swing.

Simple experiments with a ball on a string will give you an idea of how the period and frequency change with length. Try it and see if you can find a trend (see home experiment 1). The motion is regular—you can keep time by the swing of a pendulum or the motion of a mass on a spring.

### Will any restoring force produce simple harmonic motion?

When a mass attached to a spring is moved to either side of equilibrium, the spring exerts a force that pulls or pushes the mass back toward the center. We call such a force the **restoring force**. In this case, it is the elastic force exerted by the spring. In any oscillation, there must be some such restoring force.

As discussed in section 6.3, the spring force is directly proportional to the distance  $x$  of the mass from its equilibrium position ( $F = -kx$ ). The spring constant  $k$  has units of newtons per meter (N/m). Simple harmonic motion results whenever the restoring force has this simple dependence on distance. If the force varies in a more complicated way with distance, we may get an oscillation but not simple harmonic motion, and it will not produce a simple harmonic curve (fig. 6.19).



**Figure 6.20** A mass hanging from a spring will oscillate up and down with the same period as a horizontal mass-spring system using the same spring and mass.

It is generally easiest to set up a spring-mass system by suspending the spring from a vertical support and hanging a mass on the end of the spring, as in figure 6.20. This arrangement avoids the frictional forces of the tabletop in a horizontal arrangement. In the vertical setup, when the mass is pulled down and released, the system oscillates up and down rather than horizontally. Two forces then act on the mass, the spring force pulling upward and the gravitational force pulling downward.

Because the gravitational force in the vertical setup is constant, it simply moves the equilibrium point lower. The equilibrium point is where the net force is zero—the downward pull of gravity is balanced by the upward pull of the spring. The variations in the restoring force are still provided by the spring. These variations are proportional to the distance from equilibrium just as they are in the horizontal case. This system also meets the condition for simple harmonic motion. The potential energy involved, however, is the sum of the gravitational and elastic potential energies.

Gravity is the restoring force for the simple pendulum. When the pendulum bob is pulled to one side of its equilibrium position, the gravitational force acting on the bob pulls it back toward the center. The part of the gravitational force in the direction of motion is proportional to the displacement, if the displacement from equilibrium is not too large. Thus, for small *amplitudes* of swing, the simple pendulum also displays simple harmonic motion. **Amplitude** is the maximum distance from the equilibrium point.

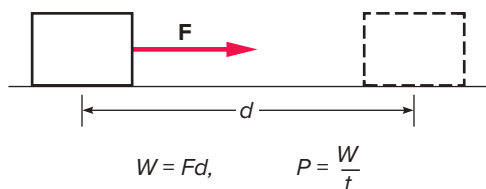
Look around for systems that oscillate. There are many examples, ranging from a springy piece of metal to a ball rolling in a depression of some kind. What force pulls back toward the equilibrium position in each case? Is the motion likely to be simple harmonic motion or a more complicated oscillation? What kind of potential energy is involved? The analysis of vibrations such as these forms an important subfield of physics that plays a role in music, communications, analysis of structures, and other areas.

Any oscillation involves a continuing interchange of potential and kinetic energies. If there are no frictional forces removing energy from the system, the oscillation will go on indefinitely. A restoring force that increases in direct proportion to the distance from the equilibrium position results in simple harmonic motion, with simple curves (harmonic functions) describing the position, velocity, and acceleration of the object over time.

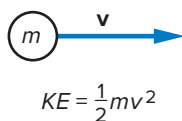
## Summary

The concept of work is central to this chapter. Energy is transferred into a system by doing work on the system, which can result in an increase in either the kinetic energy or the potential energy of the system. If no additional work is done on the system, the total energy of the system remains constant. This principle of conservation of energy allows us to explain many features of the behavior of the system.

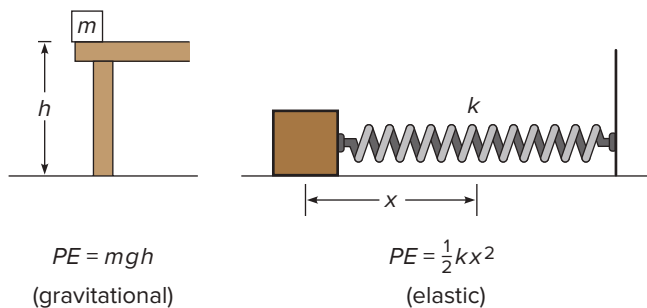
**1 Simple machines, work, and power.** Work is defined as force times the distance involved in moving an object. Only the portion of the force in the direction of the motion is used. In simple machines, work output cannot exceed work input. Power is the rate of doing work.



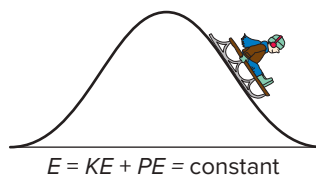
**2 Kinetic energy.** The work done by the net force acting on an object is used to accelerate the object, and the object gains kinetic energy. Kinetic energy is equal to one-half the mass of the object times the square of its speed. Negative work removes kinetic energy.



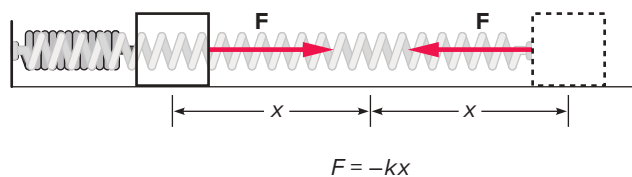
**3 Potential energy.** If work done on an object moves the object against an opposing conservative force, the potential energy of the object is increased. Two types of potential energy were considered: gravitational potential energy and elastic potential energy.



**4 Conservation of energy.** If no work is done on a system, the total mechanical energy (kinetic plus potential) remains constant. This principle of conservation of energy explains the behavior of many systems that involve exchanges of kinetic and potential energy. The system can be analyzed by energy accounting.



**5 Springs and simple harmonic motion.** The motions of a simple pendulum and of a mass on a spring both illustrate the principle of conservation of energy, but they involve different kinds of potential energy. They are also examples of simple harmonic motion, which results whenever the restoring force is proportional to the distance of the object from its equilibrium position.



The mastery quizzes in Connect will help with your conceptual understanding of many of the ideas we have introduced.

## Key Terms

Simple machine, 103  
 Mechanical advantage, 104  
 Work, 104  
 Power, 106  
 Kinetic energy, 106  
 Negative work, 107

Potential energy, 108  
 Gravitational potential energy, 108  
 Elastic force, 109  
 Spring constant, 109  
 Elastic potential energy, 109  
 Conservative forces, 110

Conservation of energy, 110  
 Simple harmonic motion, 116  
 Period, 117  
 Frequency, 117  
 Restoring force, 117  
 Amplitude, 117

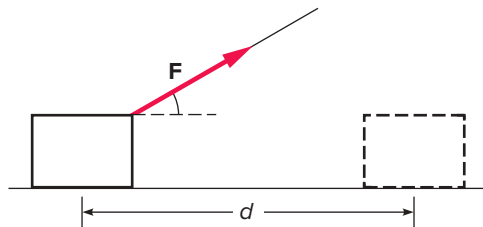
## Conceptual Questions

\* = more open-ended questions, requiring lengthier responses, suitable for group discussion

Q = sample responses are available in appendix D

Q = sample responses are available in Connect

- Q1. Equal forces are used to move blocks A and B across the floor. Block A has twice the mass of block B, but block B moves twice the distance moved by block A. Which block, if either, has the greater amount of work done on it? Explain.
- Q2. A man pushes very hard for several seconds on a heavy rock, but the rock does not budge. Has the man done any work on the rock? Explain.
- Q3. A string is used to pull a wooden block across the floor without accelerating the block. The string makes an angle to the horizontal as shown in the diagram.
- Does the force applied via the string do work on the block? Explain.
  - Is the total force or just a portion of the force involved in doing work? Explain.

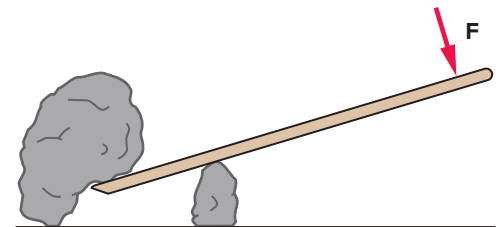


Q3 Diagram

- Q4. In the situation pictured in question 3, if there is a frictional force opposing the motion of the block, does this frictional force do work on the block? Explain.
- Q5. In the situation pictured in question 3, does the normal force of the floor pushing upward on the block do any work? Explain.
- Q6. A ball is being twirled in a circle at the end of a string. The string provides the centripetal force needed to keep the ball moving in the circle at constant speed. Does the force exerted by the string on the ball do work on the ball in this situation? Explain.
- \*Q7. A man slides across a wooden floor. What forces act on the man during this process? Which, if any, of these forces do work on the man? Explain.
- Q8. A woman uses a pulley arrangement to lift a heavy crate. She applies a force that is one-fourth the weight of the crate but moves the rope a distance four times the height that the

crate is lifted. Is the work done by the woman greater than, equal to, or less than the work done by the rope on the crate? Explain.

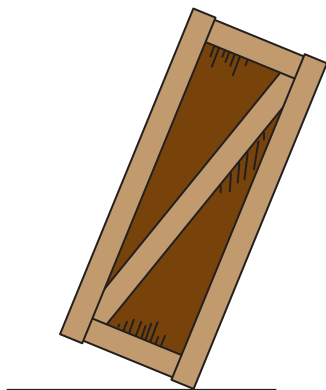
- Q9. A lever is used to lift a rock, as shown in the diagram. Will the work done by the person on the lever be greater than, equal to, or less than the work done by the lever on the rock? Explain.



Q9 Diagram

- \*Q10. A crate on rollers is pushed up an inclined plane into a truck. The pushing force required is less than half the force that would be needed to lift the crate straight up into the truck. Does the inclined plane serve as a simple machine in this situation? Explain.
- Q11. A boy pushes his friend across a skating rink. Because the frictional forces are very small, the force exerted by the boy on his friend's back is the only significant force acting on the friend in the horizontal direction. Is the change in kinetic energy of the friend greater than, equal to, or less than the work done by the force exerted by the boy? Explain.
- Q12. A child pulls a block across the floor with force applied by a horizontally held string. A smaller frictional force also acts upon the block, yielding a net force on the block that is smaller than the force applied by the string. Does the work done by the force applied by the string equal the change in kinetic energy in this situation? Explain.
- Q13. If there is just one force acting on an object, does its work necessarily result in an increase in kinetic energy? Explain.
- Q14. Two balls of the same mass are accelerated by different net forces such that one ball gains a velocity twice that of the other ball in the process. Is the work done by the net force acting on the faster-moving ball twice that done on the slower-moving ball? Explain.
- Q15. A box is moved from the floor up to a tabletop but gains no speed in the process. Is there work done on the box, and if so, what has happened to the energy added to the system?

- Q16. When work is done to increase the potential energy of an object without increasing its kinetic energy, is the *net* force acting on the object greater than zero? Explain.
- Q17. Is it possible for a system to have energy if nothing is moving in the system? Explain.
- Q18. Suppose that work is done on a large crate to tilt the crate, so that it is balanced on one edge, as shown in the diagram, rather than sitting squarely on the floor as it was at first. Has the potential energy of the crate increased in this process? Explain.



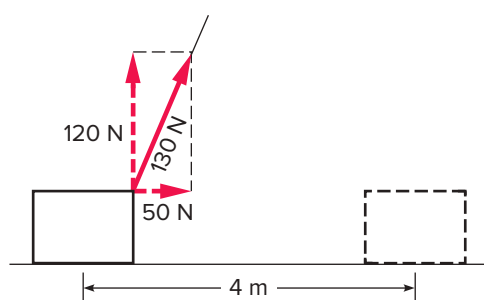
Q18 Diagram

- \*Q19. Which has the greater potential energy: a ball that is 10 feet above the ground or a ball with the same mass that is 20 feet above the bottom of a nearby 50-foot-deep well? Explain.
- Q20. When a bow and arrow are cocked, a force is applied to the string in order to pull it back. Is the energy of the system increased? Explain.
- Q21. Suppose the physics instructor pictured in figure 6.15 gives the bowling ball a push as she releases it. Will the ball return to the same point or will her chin be in danger? Explain.
- Q22. A pendulum is pulled back from its equilibrium (center) position and then released.
- What form of energy is added to the system prior to its release? Explain.
  - At what points in the motion of the pendulum after release is its kinetic energy the greatest? Explain.
  - At what points is the potential energy the greatest? Explain.
- Q23. For the pendulum in question 22, when the pendulum bob is halfway between the high point and the low point in its swing, is the total energy kinetic energy, potential energy, or both? Explain.
- Q24. Is the total mechanical energy conserved in the motion of a pendulum? Will it keep swinging forever? Explain.
- Q25. A sports car accelerates rapidly from a stop and “burns rubber.” (See everyday phenomenon box 6.1.)
- What energy transformations occur in this situation?
  - Is energy conserved in this process? Explain.
- Q26. A man commutes to work in a large SUV. (See everyday phenomenon box 6.1.)
- What energy transformations occur in this situation?
  - Is mechanical energy conserved in this situation? Explain.
  - Is energy of all forms conserved in this situation? Explain.
- Q27. Suppose we burn a barrel of oil just to warm our hands on a cold day. (See everyday phenomenon box 6.1.)
- From the standpoint of physics, is energy conserved in this process? Explain.
  - Why is this a bad idea from an economic or environmental standpoint? Explain.
- \*Q28. A bird grabs a clam, carries it in its beak to a considerable height, and then drops it on a rock below, breaking the clam shell. Describe the energy conversions that take place in this process.
- Q29. In pole vaulting, is the elastic potential energy stored in the pole the only type of potential energy involved? Explain. (See everyday phenomenon box 6.2.)
- Q30. If one pole-vaulter can run faster than another, will the faster runner have an advantage in the pole vault? Explain. (See everyday phenomenon box 6.2.)
- Q31. A mass attached to a spring, which in turn is attached to a wall, is free to move on a friction-free, horizontal surface. The mass is pulled back and then released.
- What form of energy is added to the system prior to the release of the mass? Explain.
  - At what points in the motion of the mass after its release is its potential energy the greatest? Explain.
  - At what points is the kinetic energy the greatest? Explain.
- Q32. Suppose that the mass in question 31 is halfway between one of the extreme points of its motion and the center point. In this position, is the energy of the system kinetic energy, potential energy, or a combination of these forms? Explain.
- \*Q33. A spring gun is loaded with a rubber dart. The gun is cocked, then fired at a target on the ceiling. Describe the energy transformations that take place in this process.
- Q34. Suppose that a mass is hanging vertically at the end of a spring. The mass is pulled downward and released to set it into oscillation. Is the potential energy of the system increased or decreased when the mass is lowered? Explain.
- \*Q35. A sled is given a push at the top of a hill. Is it possible for the sled to cross a hump in the hill that is higher than its starting point under these circumstances? Explain.
- \*Q36. Can work done by a frictional force ever increase the total mechanical energy of a system? (Hint: Consider the acceleration of an automobile.) Explain.
- Q37. Suppose a pulley system is used to lift a heavy crate, but the pulleys have rusted and there are frictional forces acting on the pulleys. Will the useful work output of this system be greater than, equal to, or less than the work input? Explain.

## Exercises

For the exercises in this chapter (and subsequent chapters), use the more accurate value of  $g = 9.8 \text{ m/s}^2$  for the acceleration due to gravity.

- E1. A horizontally directed force of 40 N is used to pull a box a distance of 1.5 m across a tabletop. How much work is done by the 40-N force?
- E2. A woman does 210 J of work to move a table 1.4 m across the floor. What is the magnitude of the force that the woman applied to the table if this force is applied in the horizontal direction?
- E3. A force of 80 N used to push a chair across a room does 320 J of work. How far does the chair move in this process?
- E4. A rope applies a horizontal force of 180 N to pull a crate a distance of 2 m across the floor. A frictional force of 70 N opposes this motion.
- What is the work done by the force applied by the rope?
  - What is the work done by the frictional force?
  - What is the total work done on the crate?
- E5. A force of 130 N is used to drag a crate 4 m across a floor. The force is directed at an angle upward from the crate, so that the vertical component of the force is 120 N and the horizontal component is 50 N, as shown in the diagram.
- What is the work done by the horizontal component of the force?
  - What is the work done by the vertical component of the force?
  - What is the total work done by the 130-N force?



**E5 Diagram**

- E6. A net force of 60 N accelerates a 4-kg mass over a distance of 15 m.
- What is the work done by this net force?
  - What is the increase in kinetic energy of the mass?
- E7. A 0.3-kg ball has a velocity of 20 m/s.
- What is the kinetic energy of the ball?
  - How much work would be required to stop the ball?
- E8. A box with a mass of 7.0 kg is lifted (without acceleration) through a height of 1.5 m, in order to place it on the shelf of a closet.
- What is the increase in potential energy of the box?
  - How much work was required to lift the box to this position?
- E9. A leaf spring in an off-road truck with a spring constant  $k$  of 87.6 kN/m (87,600 N/m) is compressed a distance of 6.2 cm (0.062 m) from its original, unstretched position. What is the increase in potential energy of the spring (in kJ)?
- E10. To stretch a spring a distance of 0.30 m from the equilibrium position, 180 J of work is done.
- What is the increase in potential energy of the spring?
  - What is the value of the spring constant  $k$  of the spring?
- E11. A 5-kg rock is going to be moved either vertically or horizontally.
- What is the increase in the potential energy of the rock when lifting it to a height of 1.8 m without acceleration?
  - What is the increase in kinetic energy to accelerate the same rock horizontally from rest to a speed of 6 m/s?
  - Which requires more work: lifting the rock 1.8 m or accelerating it horizontally to a speed of 6 m/s?
- E12. At the low point in its swing, a pendulum bob with a mass of 0.15 kg has a velocity of 3 m/s.
- What is its kinetic energy at the low point?
  - What is its kinetic energy at the high point?
  - What is its potential energy at the high point (assuming the potential energy at the low point was zero)?
  - Ignoring air resistance, how high will the bob swing above the low point before reversing direction?
- E13. A 0.40-kg mass attached to a spring is pulled back horizontally across a table, so that the potential energy of the system is increased from zero to 150 J. Ignoring friction, what is the kinetic energy of the system after the mass is released and has moved to a point where the potential energy has decreased to 60 J?
- E14. A sled and rider with a combined mass of 70 kg are at the top of a hill that rises 9 m above the level ground below. The sled is given a push, providing an initial kinetic energy at the top of the hill of 1200 J.
- Choosing a reference level at the bottom of the hill, what is the potential energy of the sled and rider at the top of the hill?
  - After the push, what is the total mechanical energy of the sled and rider at the top of the hill?
  - If friction can be ignored, what will be the kinetic energy of the sled and rider at the bottom of the hill?
- E15. A roller-coaster car has a potential energy of 400,000 J (400 kJ) and a kinetic energy of 130,000 J (130 kJ) at point A in its travel. At the low point of the ride, the potential energy is zero, and 60,000 J (60 kJ) of work has been done against friction since it left point A. What is the kinetic energy of the roller coaster at this low point (in kJ)?
- E16. A roller-coaster car with a mass of 900 kg starts at rest from a point 22 m above the ground. At point B, it is 8 m above the ground. [Express your answers in kilojoules (kJ).]
- What is the initial potential energy of the car?
  - What is the potential energy at point B?
  - If the initial kinetic energy was zero and the work done against friction between the starting point and point B is 30,000 J (30 kJ), what is the kinetic energy of the car at point B?

- E17. A 300-g mass lying on a frictionless table is attached to a horizontal spring with a spring constant of 500 N/m. The spring is stretched a distance of 46 cm (0.46 m).
- What is the initial potential energy of the system?
  - What is the kinetic energy of the system when the mass returns to the equilibrium position after being released?

- E18. The time required for one complete cycle of a mass oscillating at the end of a spring is 0.40 s. What is the frequency of oscillation?
- E19. The frequency of oscillation of a pendulum is 16 cycles/s. What is the period of oscillation?

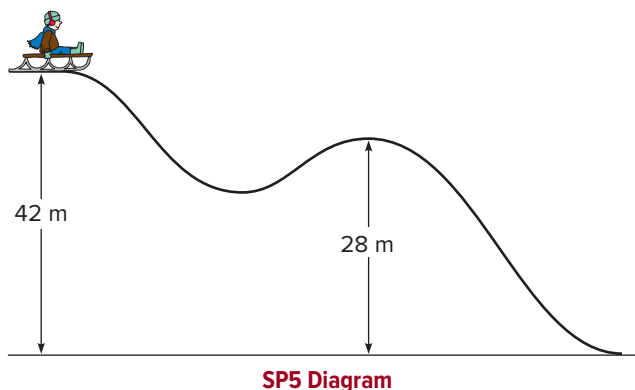
## Synthesis Problems

For the synthesis problems in this chapter (and subsequent chapters), use the more accurate value of  $g = 9.8 \text{ m/s}^2$  for the acceleration due to gravity.

- SP1. Suppose that two horizontal forces are acting upon a 0.38-kg wooden block as it moves across a laboratory table: a 6-N force pulling the block and a 2-N frictional force opposing the motion. The block moves a distance of 1.7 m across the table.
- What is the work done by the 6-N force?
  - What is the work done by the net force acting upon the block?
  - Which of these two values should you use to find the increase in kinetic energy of the block? Explain.
  - What happens to the energy added to the system via the work done by the 6-N force? Can it all be accounted for? Explain.
  - If the block started from rest, what are its kinetic energy and velocity at the end of the 1.7-m motion?
- SP2. As described in example box 6.2, a 120-kg crate is accelerated by a net force of 96 N applied for 4 s.
- What is the acceleration of the crate from Newton's second law?
  - If it starts from rest, how far does it travel in the time of 4 s? (See section 2.5 in chapter 2.)
  - How much work is done by the 96-N net force?
  - What is the velocity of the crate at the end of 4 s?
  - What is the kinetic energy of the crate at this time? How does this value compare to the work computed in part c?
- SP3. A slingshot consists of a rubber strap attached to a Y-shaped frame, with a small pouch at the center of the strap to hold a small rock or other projectile. The rubber strap behaves much like a spring. Suppose that for a particular slingshot a spring constant of 700 N/m is measured for the rubber strap. The strap is pulled back approximately 30 cm (0.3 m) prior to being released.
- What is the potential energy of the system prior to release?
  - What is the maximum possible kinetic energy that can be gained by the rock after release?
  - If the rock has a mass of 40 g (0.04 kg), what is its maximum possible velocity after release?
  - Will the rock actually reach these maximum values of kinetic energy and velocity? Does the rubber strap gain kinetic energy? Explain.
- SP4. Suppose that a 300-g (0.30-kg) mass is oscillating at the end of a spring on a horizontal surface that is essentially friction-free. The spring can be both stretched and compressed and has a spring constant of 400 N/m. It was originally

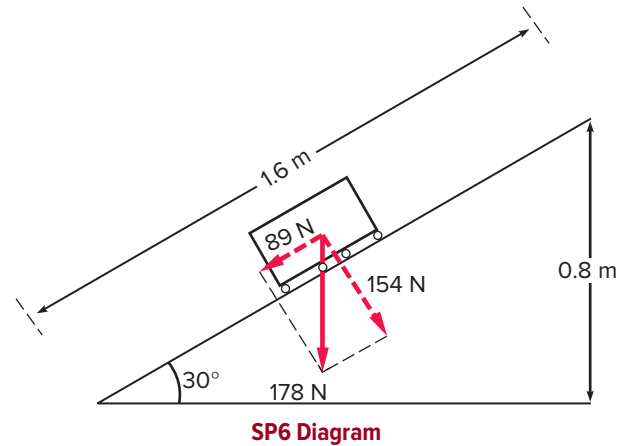
stretched a distance of 12 cm (0.12 m) from its equilibrium (unstretched) position prior to release.

- What is its initial potential energy?
  - What is the maximum velocity that the mass will reach in its oscillation? Where in the motion is this maximum reached?
  - Ignoring friction, what are the values of the potential energy, kinetic energy, and velocity of the mass when the mass is 6 cm from the equilibrium position?
  - How does the value of velocity computed in part c compare to that computed in part b? (What is the ratio of the values? This is interesting, because even though you are midway between the equilibrium point and the maximum displacement, the velocity is much closer to the maximum value you found in part b.)
- SP5. A sled and rider with a total mass of 50 kg are perched at the top of a hill, as pictured in the diagram. The top of this hill is 42 m above the low point in the path of the sled. A second hump in the hill is 28 m above this low point. Suppose we also know that approximately 3600 J of work is done against friction as the sled travels between these two points.
- Will the sled make it to the top of the second hump if no kinetic energy is given to the sled at the start of its motion? Explain.
  - What is the maximum height that the second hump can be in order for the sled to reach the top, assuming that the same work against friction will be involved and that no initial push is provided? Explain.



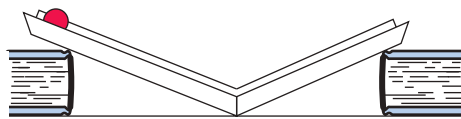
- SP6. Suppose you wish to compare the work done by pushing a box on rollers up a ramp to the work done if you lift the box straight up to the same final height.
- What work is required to lift a 178-N box (about 40 lb) up to a table that is 0.8 m off the floor?

- b. Let's assume you also have a ramp available that makes an angle of  $30^\circ$  with the horizontal, as shown in the diagram. The ramp is 1.6 m long. The weight of the box (178 N) is due to the Earth's pulling on the box. This 178 N is a force directed straight down. If you push it up a ramp, you are doing work against only the component of this weight along the ramp, which is 89 N, as shown in the diagram. How much work does it require to push the box up the ramp, assuming no friction?
- c. Which situation (pushing up the ramp or lifting straight up) requires more work?
- d. Which situation requires more force?
- e. For which situation is the distance moved greater?
- f. What is the change in the gravitational potential energy of the box for each situation?
- g. What advantage, if any, is there to using the ramp? Explain.



## Home Experiments and Observations

- HE1. You can easily construct a simple pendulum by attaching a ball to a string (with tape or a staple) and fixing the other end of the string to a rigid support. (A pencil taped firmly to the end of a desk or table will do nicely.)
- The frequency of oscillation can be measured by timing the swings. The usual method is to use a watch to measure the time required for 10 or more complete swings. The period  $T$  (the time required for 1 swing) is then the total time divided by the number of swings counted, and the frequency  $f$  is just  $1/T$ .
  - How does the frequency change if you vary the length of your pendulum? (Try at least three different lengths.)
- HE2. A ramp for a marble or small steel ball can be made by bending a long strip of cardboard into a V-shaped groove. Two such ramps can be placed end to end, as pictured in the diagram, to produce a track in which the marble will oscillate.
- Can you measure a frequency of oscillation for this system? Does this frequency depend upon how high up the ramp the marble starts?
  - How high up the second ramp does the marble go? Is more energy lost per cycle in this system than for a pendulum?



**HE2 Diagram**

- HE3. The height to which a ball bounces after being dropped provides a measure of how much energy is lost in the collision with the floor or other surface. A small portion of the energy is lost to air resistance as the ball is moving, but most is lost in the collision.
- Trying a number of different balls that you may have available, test the height of the bounce using the same height of release for all of the balls tested. Which ball loses the most energy, and which the least?
  - Can you explain why many balls return to a higher height than a marble will? What characteristics of the balls tested give the best bounce?
  - For a ball that bounces several times, does the period (time between bounces) change with each bounce? Does the bouncing ball undergo simple harmonic motion?



D. Hurst/Alamy Stock Photo

## Momentum

### Chapter Overview

In this chapter, we explore momentum and impulse and examine the use of these concepts in analyzing events such as a collision between two opposing athletes. The principle of conservation of momentum is introduced and its limits explained. A number of examples shed light on how these ideas are used, particularly conservation of momentum. Momentum is central to all of these topics—it is a powerful tool for understanding a lot of life's sudden changes.

### Chapter Outline

- 1 Momentum and impulse.** How can rapid changes in motion be described using the ideas of momentum and impulse? How do these ideas relate to Newton's second law of motion?
- 2 Conservation of momentum.** What is the principle of conservation of momentum, and when is it valid? How does this principle follow from Newton's laws of motion?
- 3 Recoil.** How can we explain the recoil of a rifle or shotgun using momentum? How is this similar to what happens in firing a rocket?
- 4 Elastic and inelastic collisions.** How can collisions be analyzed using conservation of momentum? What is the difference between an elastic and an inelastic collision?
- 5 Collisions at an angle.** How can we extend momentum ideas to two dimensions? How does the game of pool resemble automobile collisions?

The word *momentum* is overused by sports announcers to mean changes in the flow of a game. The “old mo” that announcers talk about bears only a metaphorical relationship to the physical concept of momentum. There are plenty of real examples of changes in momentum for us to consider in both the world of sports and the world more generally.

Consider the collision between a hard-charging fullback and a defensive back on the football field (fig. 7.1). If they meet head-on, the velocity of the fullback is sharply reduced, although the two players might continue moving briefly in the original direction of the fullback’s velocity. If the defensive back is moving before the collision, his velocity also changes abruptly. There must be strong forces at work to produce these accelerations, but these forces act for only an instant. How do we use Newton’s laws to analyze this event?

Momentum, impulse, and conservation of momentum figure in any discussion of collisions. The total momentum of the fullback and defensive back is involved in predicting what will happen after the collision. How is momentum defined, and what does conservation of momentum have to do with Newton’s laws? How is conservation of momentum useful in predicting what happens in collisions? These questions will



**Figure 7.1** A collision between a running back and a defensive back (in red, center of the photograph). How will the two players move after the collision? Source: U.S. Air Force photo by John Van Winkle

be addressed as we examine a variety of collisions and other high-impact events.

## 7.1 Momentum and Impulse

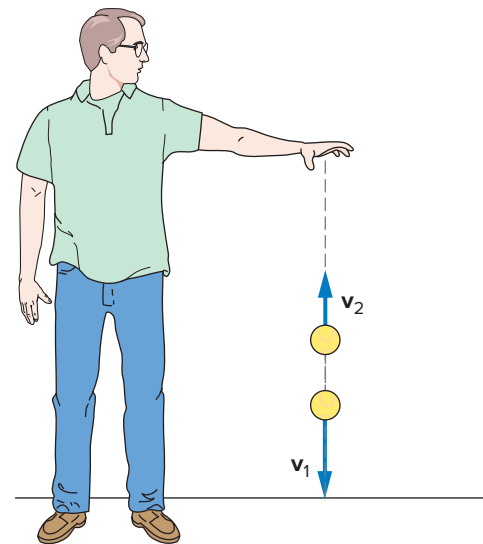
Imagine a baseball heading toward the catcher’s mitt when its flight is rudely interrupted by the impact of a bat. In a very short time, the velocity of the ball changes direction and it is accelerated in the direction opposite its original flight. Similar changes happen when a tennis racket hits a ball or when a ball bounces off a wall or the floor. In many everyday situations, a brief impact causes a rapid change in an object’s velocity.

The forces responsible for such rapid changes in motion can be large, but they act for very short times and are difficult to measure. Not only are they brief, but they may change rapidly *during* the collision.

### What happens when a ball bounces?

Consider the seemingly simple example of dropping a tennis ball. The ball is initially accelerated downward by the gravitational force. When it reaches the floor, its velocity quickly changes in direction, and the ball heads back up toward you (fig. 7.2). There must be a strong force exerted on the ball by the floor during the short time they are in contact. This force provides the upward acceleration necessary to change the direction of the ball’s velocity.

If we used a high-speed camera to catch the action during the time the ball is in contact with the floor, we would see that the ball’s shape is distorted (fig. 7.3). The ball behaves like a spring, first compressing as it moves downward, then expanding (springing back) as it begins to move upward. A



**Figure 7.2** A tennis ball bouncing off the floor. There is a rapid change in the direction of the velocity when the ball hits the floor.

quick test (squeezing the ball with your hands) will persuade you that a strong force is required to distort the ball.

What we have, then, is a *strong force acting for a very brief time*, producing a rapid acceleration that quickly changes the ball’s velocity from a downward direction to an upward one. The magnitude of the ball’s velocity decreases rapidly to zero and then increases equally rapidly in the opposite direction. This all happens in a time so short that we would miss it if we blinked.



**Figure 7.3** Two high-speed photographs of a ball hitting a tabletop, one just before the impact and the other after the impact. The ball is compressed like a spring. (both): Ted Kinsman/Science Source

### How can we analyze such rapid changes?

We have described the collision of the ball with the floor using force and acceleration, and we could also use Newton's second law to predict how the velocity actually changes. The problem with this approach is that the time of the interaction is very short, and the force itself varies during this short time, so it is hard to describe the collision accurately. It is more productive to look at the *total change in motion* in this brief interaction.

We introduced Newton's second law in chapter 4 using the expression  $\mathbf{F}_{\text{net}} = m\mathbf{a}$ . The acceleration  $\mathbf{a}$  is the *rate of change* in velocity, which can be expressed as the change in velocity  $\Delta\mathbf{v}$  divided by the time interval  $\Delta t$  required to produce that change. The time interval is important: The shorter the time for a given change in velocity, the larger the acceleration and the force needed to produce this change.

We can restate Newton's second law as

$$\mathbf{F}_{\text{net}} = m \left( \frac{\Delta\mathbf{v}}{\Delta t} \right)$$

expressing the acceleration in terms of the change in velocity. Multiplying both sides of this equation by the time interval  $\Delta t$  recasts the second law as

$$\mathbf{F}_{\text{net}} \Delta t = m\Delta\mathbf{v}$$

While this is still Newton's second law, rewriting it offers us a different way of looking at events. This new view is more convenient for describing the overall change in motion.

### What are impulse and momentum?

Impulse shows up as the quantity on the left side of the recast second law,  $\mathbf{F}_{\text{net}} \Delta t$ . **Impulse** is the force acting on an object multiplied by the time interval over which the force acts. If the force varies during this time interval, and it often does, we must use the *average* value of the force over this time interval.

Impulse is the average force multiplied by its time interval of action:

$$\text{impulse} = \mathbf{F}\Delta t$$

Because force is a vector quantity, impulse is also a vector in the direction of the average force.

How a force changes the motion of an object depends on both the size of the force and how long the force acts. The stronger the force, the larger the effect, and the longer the force acts, the greater its effect. Multiplying the two factors together to get the impulse shows the overall effect of the force.

On the right side of our recast second law,  $m\Delta\mathbf{v}$  is the mass of the object multiplied by the change in velocity produced by the impulse. This product is the change in the *quantity of motion*, to use Newton's own term. We now call this product the *change in linear momentum* of the object, where **linear momentum** is defined thus:

Linear momentum is the product of the mass of an object and its velocity, or

$$\mathbf{p} = m\mathbf{v}$$

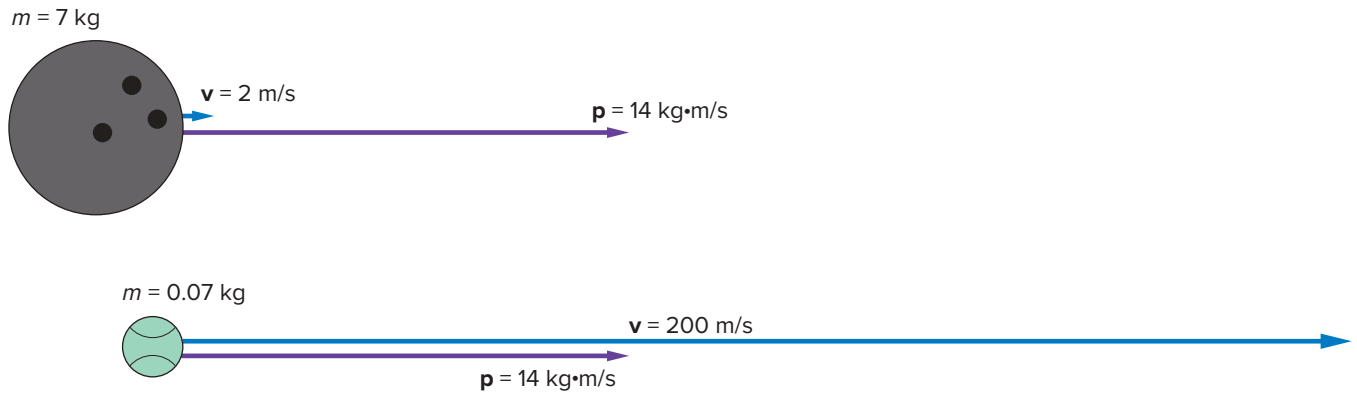
The symbol  $\mathbf{p}$  is often used for linear momentum. If the mass of the object is constant, the change in linear momentum is the mass times the change in velocity, or  $\Delta\mathbf{p} = m\Delta\mathbf{v}$ .

At this point, we are dealing only with motion in a straight line, so we will drop the term *linear* and just refer to  $\mathbf{p}$  as the momentum. In section 8.4, we will introduce angular momentum, and we will then be sure to distinguish between angular and linear momentum.

Like velocity, momentum is a vector and has the same direction as the velocity vector. Two different objects traveling in the same direction can have different masses and velocities but still have the same momentum. For example, a 7-kg bowling ball moving with the relatively slow speed of 2 m/s would have a momentum of 14 kg·m/s. On the other hand, a tennis ball with a mass of just 0.07 kg, moving with the much larger velocity of 200 m/s, has the same momentum as the bowling ball, 14 kg·m/s (fig. 7.4).

Using these definitions of impulse and momentum, we can state our recast form of Newton's second law as

$$\begin{aligned} \text{impulse} &= \text{change in momentum} \\ &= \Delta\mathbf{p} \end{aligned}$$



**Figure 7.4** A bowling ball and a tennis ball with the same momentum. The tennis ball with its smaller mass must have a much larger velocity.

This statement of the second law is sometimes called the **impulse-momentum principle**:

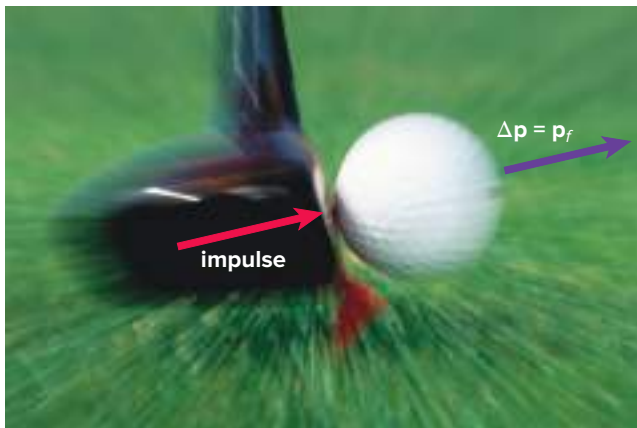
The impulse acting on an object produces a change in momentum of the object that is equal in both magnitude and direction to the impulse.

This principle is not a new law but another way of expressing Newton's second law of motion. It is particularly useful for looking at collisions.

### How do we apply the impulse-momentum principle?

The impulse-momentum principle applies to almost any collision. Whacking a golf ball with a golf club is a good example (fig. 7.5). The impulse delivered by the golf club produces a change in the golf ball's momentum, also described in example box 7.1. Note that the units of impulse (force multiplied by time, or N·s) must equal those of momentum (mass times velocity, or kg·m/s).

Does the momentum of the bouncing tennis ball we discussed earlier change when it hits the floor? Even if the ball



**Figure 7.5** An impulse is delivered to the golf ball by the head of the club. If the initial momentum of the ball is zero, the final momentum is equal to the impulse delivered. *Stephen Marks/Getty Images*

## Example Box 7.1

### Sample Exercise: The Momentum and Impulse of Golf

A golf club exerts an average force of 500 N on a 0.1-kg golf ball, but the club is in contact with the ball for only a hundredth of a second.

- What is the magnitude of the impulse delivered by the club?
- What is the change in velocity of the golf ball?

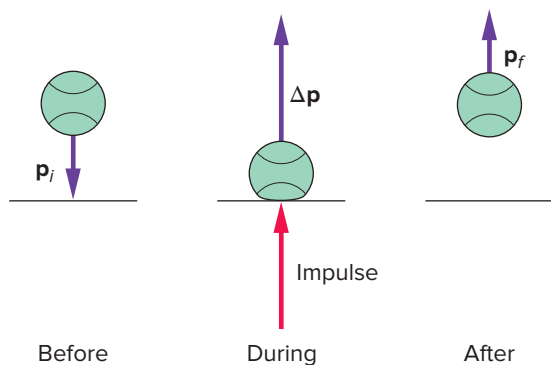
$$\begin{aligned} \text{a. } F &= 500 \text{ N} & \text{impulse} &= F\Delta t \\ \Delta t &= 0.01 \text{ s} & &= (500 \text{ N})(0.01 \text{ s}) \\ \text{impulse} &= ? & &= 5 \text{ N}\cdot\text{s} \end{aligned}$$

$$\begin{aligned} \text{b. } m &= 0.1 \text{ kg} & \text{impulse} &= \Delta p = m\Delta v \\ \Delta v &= ? & \Delta v &= \frac{\text{impulse}}{m} \\ & & &= \frac{5 \text{ N}\cdot\text{s}}{0.1 \text{ kg}} \\ & & &= 50 \text{ m/s} \end{aligned}$$

Because the golf ball started at rest, this change in velocity equals the velocity of the ball as it leaves the face of the club. The direction of this velocity is the same as the impulse of the force exerted by the club.

loses no energy in its collision with the floor and bounces back with the same speed and kinetic energy it had just before hitting the floor, the momentum changes, because its direction changes. The momentum decreases to zero as the ball comes to a momentary halt, and it changes again as the ball gains momentum in the opposite direction (fig. 7.6). The total change in momentum is larger than the change that would happen if the tennis ball stopped and did not bounce.

When the tennis ball bounces back with the same speed, the total change in momentum is *twice* the value of the momentum just before the ball hits the floor. Its final momentum is  $m\mathbf{v}$ , where the direction of  $\mathbf{v}$  is upward, but its *initial* momentum was  $-m\mathbf{v}$ , because the initial velocity was directed downward. We find the change in momentum by subtracting



**Figure 7.6** The impulse exerted by the floor on the tennis ball produces a change in its momentum.

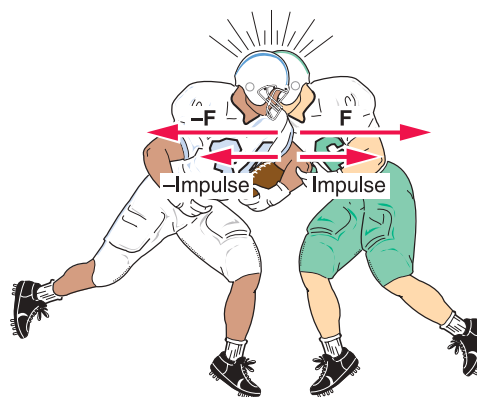
the initial value from the final value:  $m\mathbf{v} - (-m\mathbf{v}) = 2m\mathbf{v}$ . The impulse required to produce this change in momentum is twice as large as what is needed simply to stop the ball.

There are many practical lessons involving impulse and change in momentum. Why does it help to pull your hand back as you catch a hard-thrown ball? When you pull your hand back, you lengthen the time interval  $\Delta t$ . This reduces the average force that your hand must exert on the ball, because impulse is the product of the force and the time interval ( $\mathbf{F}\Delta t$ ). If the time interval is longer, the force can be smaller yet still produce the same impulse and change in momentum. It hurts less this way! A padded dashboard or an air bag similarly lessens injury to passengers by increasing the time interval required to bring them to a halt in a collision. Another practical lesson involving impulse and change in momentum is described in everyday phenomenon box 7.1.

► **non box 7.1.**

Everything we have done in this section is just another way of working with Newton's second law of motion. In fact, by dividing both sides of the impulse-momentum principle by the time interval  $\Delta t$ , Newton's second law can be expressed in the form that most nearly captures the meaning of Newton's original statement of the second law,  $\mathbf{F}_{\text{net}} = \Delta\mathbf{p}/\Delta t$ . In words, this form of the second law says that the net force acting on an object is equal to the rate of change in momentum of the object. This form covers a wider range of situations than the more familiar  $\mathbf{F}_{\text{net}} = m\mathbf{a}$ .

Momentum and impulse are most useful for evaluating events such as collisions, where powerful forces act briefly to produce striking changes in the motion of objects. The impulse-momentum principle states that the change in momentum is equal to the impulse. This is a different way of stating Newton's second law. The impulse, the product of the average force and the time interval that it is applied, allows us to predict the change in momentum of the object. Large impulses yield large changes in momentum.



**Figure 7.7** Two American football players colliding. The impulses acting on the two players are equal in magnitude but opposite in direction.

## 7.2 Conservation of Momentum

How do impulse and momentum help to explain the collision between the athletes mentioned in the chapter introduction? The conditions described in section 7.1 are certainly present. The defensive back exerts a sizable but brief force on the fullback (fig. 7.7), and the momentum of both players changes rapidly in the collision.

The principle of **conservation of momentum** provides the key to understanding such a collision. This principle arises when we apply Newton's *third law* to impulse and changes in momentum. Conservation of momentum allows us to predict many features of collisions without requiring detailed knowledge of the forces of impact.

### Why and when is momentum conserved?

Let's take a more detailed look at the head-on collision between the hard-charging fullback and the defensive back. To simplify the situation, we assume that the two players meet in midair and that after the collision they move together, with the fullback held in the tackle of the defensive back (fig. 7.7). What happens when they collide?

During the collision, the defensive back exerts a strong force on the fullback, and by Newton's third law, the fullback exerts a force equal in magnitude but opposite in direction on the defensive back. Because the time interval of action  $\Delta t$  is the same for both forces, the impulses  $\mathbf{F}\Delta t$  must also be equal in magnitude but opposite in direction. From the impulse-momentum principle (Newton's second law), changes in the momentum  $\Delta\mathbf{p}$  for each player are also equal in magnitude but opposite in direction.

If the two players experience equal but oppositely directed momentum changes, the *total change* in momentum of the two players together is zero. We look at the overall *system* and define the total momentum of that system as the sum of the momentum values of the two players. There is no

## Everyday Phenomenon

## Box 7.1

### The Egg Toss

**The Situation.** Have you ever competed to see how far you and a partner can successfully throw and catch a raw egg? The most successful technique involves moving your hand back as the egg lands in it. Why does this technique reduce the likelihood of the egg's breaking? What does this have to do with momentum and impulse? How can your physics knowledge reduce the chances of a raw egg bath? The same principles apply when catching water balloons.

**The Analysis.** When you throw an egg or a balloon toward your partner, you apply a force and give it momentum. When your partner catches it and brings it to a stop, the object experiences a change in momentum. That change in momentum is equal to the impulse, as discussed earlier in the text. The impulse is also equal to the product of the force of the hand on the object multiplied by the time that force is applied. Therefore, by the impulse-momentum principle, the change in momentum is equal to the force of the hand on the egg multiplied by the time that force is applied:  $\Delta p = F\Delta t$ .

Unlike a golf swing or a bat hitting a baseball, the idea here is not to increase the change in momentum; the idea is to minimize the force applied to the egg, so that it won't break. It is the strength of the force that will break the egg. The larger the force applied by your hand in catching the egg, the more likely it is you will be splattered.

Once the egg leaves the thrower's hand, it has a certain momentum that stays the same as it travels from the thrower to the catcher. We say this momentum is fixed. The impulse required to reduce this momentum to zero is therefore also fixed; it does not change. Because  $F\Delta t$  is fixed, if you wish to decrease the force applied to the egg, the time interval  $\Delta t$  involved in the catch must be increased. We say that force and time are inversely proportional to each other. As one increases, the other decreases *in proportion*.  $F$  is proportional to  $1/\Delta t$ . ( $F$  is proportional to the inverse of  $\Delta t$ .)

The idea of inverse proportionality comes up frequently in everyday life but is not always recognized or understood. To take a simple example, let's say you have \$2.00 to spend on candy. If you buy candy pieces that cost 10¢ each, you will get 20 pieces of candy. If, instead, you buy candy pieces that cost 25¢ each, you can buy only 8 pieces of candy. The more expensive the candy, the fewer pieces can be purchased, a fact that most of us can easily recognize.

In this example, the amount of money you have to spend is fixed, and it must equal the total cost of the candy, which is the product of the price per piece times the number of pieces. The number of pieces of candy you can buy and the price of each piece of candy are therefore inversely



ISHARA S.KODIKARA/AFP/Getty Images

proportional to one another. As one increases, the other must decrease in proportion.

As we have already indicated, inverse proportionality is involved in catching the egg. The impulse is fixed, so force and time are inversely proportional to one another. As you increase one (say, the time to stop it), the other (the force applied) decreases. Your objective is, then, to make the time involved in stopping the egg as long as possible.

How can this be done? You can increase the time involved in the catch substantially by moving your hand back as the egg reaches it. This should be done as smoothly as possible, so that the velocity (and momentum) of the egg decreases to zero much more gradually than if your hand were stationary. Using this technique, the average force applied to the egg can be made much smaller than that involved in a sudden stop. With luck, this force will be small enough that the egg will not break!

This same principle has many applications. Air bags in cars reduce the force applied to your head in a collision by increasing the time it takes your head to come to a stop. Gym floors have more “give” to them to reduce the force on players' knees when jumping and landing on the floor. Dropping a wineglass on a carpeted floor will make a mess by staining the carpet, but it is far less likely to break the glass than if it is dropped onto a concrete floor. In all of these examples, the force has decreased, because the time it takes to stop the object has increased. You may not be able to measure the decrease in time with a stopwatch, because the times involved are very short, but you can see the evidence of the increased time in the result.

The next time you have a picnic, take some raw eggs or water balloons and apply the impulse-momentum principle with your friends and family. With water balloons, good technique will keep you dry, but sometimes it is more fun to get wet.

change in the momentum of this system because the changes in the momentums of the parts cancel one another. The total momentum of the system is *conserved*.

To reach this conclusion, we ignored external forces (produced by other objects) acting on the two players and assumed that the only significant forces were their own forces of interaction. The forces they exert on one another are *internal* to the system consisting of both players. The principle of conservation of momentum can therefore be stated as follows:

If the net external force acting on a system of objects is zero, the total momentum of the system is conserved.

The forces of interaction between the objects in a system are internal forces whose effects on the total momentum cancel one another, because of Newton's third law of motion. Different portions of the system can exchange momentum without affecting the total momentum of the system. If there is a net *external* force acting on the system because of interaction with some object that is not part of the system, the entire system will be accelerated—and the momentum of the system will change.

### Conservation of momentum and collisions

Using the principle of conservation of momentum, what information can we obtain about the results of a collision (like the one between two football players)? If we know the masses of the players and their initial velocities, we can find how fast and in what direction the players will move after they collide. We do not need to know anything about the details of the strong forces involved in the collision itself.

The sample exercise in example box 7.2 treats a head-on collision between a fullback and a defensive back using realistic numerical values. The fullback has a mass of 100 kg (equivalent to a weight of about 220 lb) and is moving straight downfield with a velocity of 5 m/s through the hole created by his linemen. The somewhat smaller defensive back charges up to meet him with a velocity in the opposite direction of  $-4$  m/s (fig. 7.8). The minus sign indicates direction: We have chosen the fullback's direction of motion to be positive.

The total momentum of the system before the collision in example box 7.2 is found by adding the initial momentum of the fullback to the momentum of the defensive back, taking into account the difference in sign. If we assume that both players' feet leave the ground just before the collision (so that there are no frictional forces between their feet and the ground), momentum should be conserved in the collision. The total momentum of the two players moving together after the collision has the same value it had immediately before the collision (fig. 7.9).

## Example Box 7.2

### Sample Exercise: A Head-on Collision

A 100-kg fullback moving straight downfield with a velocity of 5 m/s collides head-on with a 75-kg defensive back moving in the opposite direction with a velocity of  $-4$  m/s. The defensive back hangs on to the fullback, and the two players move together after the collision.

- What is the initial momentum of each player?
- What is the total momentum of the system?
- What is the velocity of the two players immediately after the collision?

a. *fullback:*

$$\begin{aligned} m &= 100 \text{ kg} & p &= mv \\ v &= 5 \text{ m/s} & &= (100 \text{ kg})(5 \text{ m/s}) \\ p &= ? & &= \mathbf{500 \text{ kg}\cdot\text{m/s}} \end{aligned}$$

*defensive back:*

$$\begin{aligned} m &= 75 \text{ kg} & p &= mv \\ v &= -4 \text{ m/s} & &= (75 \text{ kg})(-4 \text{ m/s}) \\ & & &= \mathbf{-300 \text{ kg}\cdot\text{m/s}} \end{aligned}$$

b.  $p_{\text{total}} = ?$        $p_{\text{total}} = p_{\text{fullback}} + p_{\text{defensive back}}$

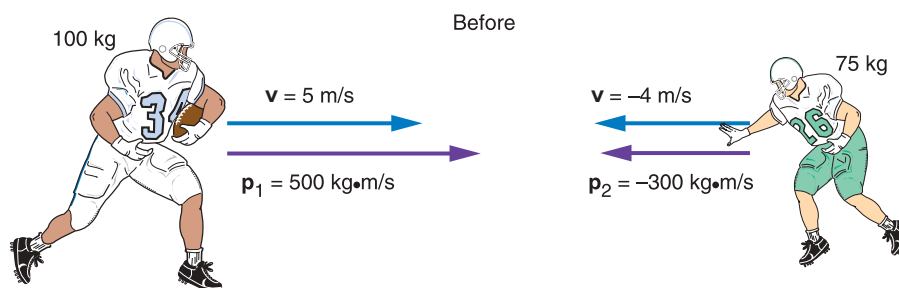
$$\begin{aligned} &= 500 \text{ kg}\cdot\text{m/s} + (-300 \text{ kg}\cdot\text{m/s}) \\ &= \mathbf{200 \text{ kg}\cdot\text{m/s}} \end{aligned}$$

c.  $v = ?$  (for both players after the collision)

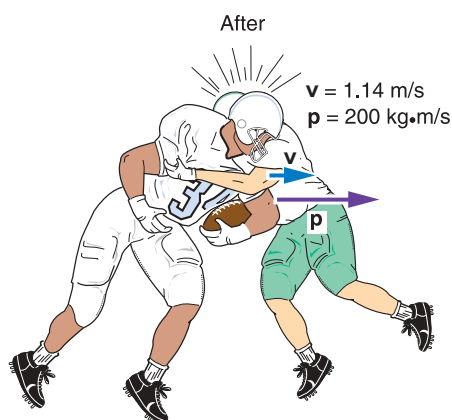
$$\begin{aligned} m &= 100 \text{ kg} + 75 \text{ kg} & p &= mv \\ &= 175 \text{ kg} & v &= \frac{p_{\text{total}}}{m} \\ & & &= \frac{200 \text{ kg}\cdot\text{m/s}}{175 \text{ kg}} \\ & & &= \mathbf{1.14 \text{ m/s}} \end{aligned}$$

The positive value of the momentum after the collision means that the two players are traveling in the direction of the fullback's initial motion. The fullback had a larger initial momentum than the defensive back, so his direction of motion prevails when the two values are added. The defensive back will be carried backward briefly before the two players hit the turf.

Conservation of momentum results when the changes in momentum of different parts of a system cancel each other by Newton's third law. If there are no external forces acting on the system, its total momentum is conserved. The principle applies to all sorts of situations involving collisions and explosions or other forms of brief but forceful interaction between objects.



**Figure 7.8** The two players before the collision, with velocity and momentum vectors for each.



**Figure 7.9** The two players after the collision, with velocity and momentum vectors indicated.



**Figure 7.10** Two skaters of different masses prepare to push off against one another. Which one will gain the larger velocity?

## 7.3 Recoil

Why does a shotgun slam against your shoulder when fired, sometimes with painful consequences? How can a rocket accelerate in empty space when there is nothing there to push against but itself? These are examples of the phenomenon of recoil, a common part of everyday experience. Conservation of momentum is the key to understanding recoil.

### What is recoil?

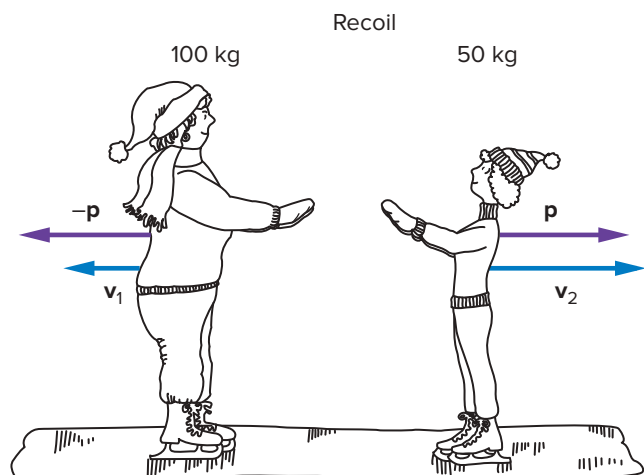
Imagine two ice skaters facing each other and pushing against each other with their hands (fig. 7.10). The frictional forces between their skates and the ice are presumably very small, so we can neglect them. The upward normal force and the downward force of gravity cancel each other, too, because we know that there is no acceleration in the vertical direction. The net external force acting on the system of the two skaters is effectively zero, and conservation of momentum should apply.

How do we apply conservation of momentum in this situation? Because neither skater is moving before the push-off,

the initial total momentum of the system is zero. If momentum is conserved, the total momentum of the system after the push-off will also be zero. How can the total momentum be zero when at least one of the skaters is moving? Both skaters must move with momentum values equal in magnitude but opposite in direction  $\mathbf{p}_2 = -\mathbf{p}_1$ . The momentum of the second skater  $\mathbf{p}_2$  must be opposite that of the first skater  $\mathbf{p}_1$ . When added together to find the total momentum of the system, these individual values will cancel each other to produce a total momentum of zero.

After the push-off, the two skaters move in opposite directions with momentum vectors equal in magnitude (fig. 7.11), but their velocities are not of equal magnitude. Because momentum is mass times velocity ( $\mathbf{p} = m\mathbf{v}$ ), the skater with the smaller mass must have the larger velocity





**Figure 7.11** The two skaters after pushing off, with the velocity and momentum vectors indicated.

to yield the same magnitude of momentum as the larger skater. Suppose the smaller skater's mass is just half the mass of the larger skater. The smaller skater's velocity will then be twice as large as that of the larger skater after pushing off.

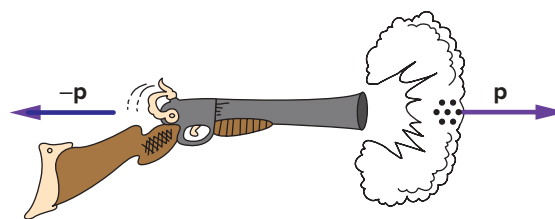
The ice skaters illustrate the basics of **recoil**. A brief force between two objects causes the objects to move in opposite directions. The lighter object attains the larger velocity to equalize the magnitudes of the momentums of the two objects. The total momentum for the system after the push-off equals zero, the value of the momentum of the system before the push-off if the objects were initially at rest. The total momentum of the system is conserved and does not change.

### Recoil of a shotgun

If you have ever fired a shotgun without holding it firmly against your shoulder, you have probably had a painful experience of recoil. What happened? The explosion of the powder in a shotgun causes the shot to move very rapidly in the direction of the gun's aim. If the gun is free to move, it will recoil in the opposite direction, with a momentum equal in magnitude to the momentum of the shot (fig. 7.12).

Even though the mass of the shot is considerably less than that of the shotgun, the momentum of the shot is quite large as a result of its large velocity. If the external forces acting on the system can be ignored, the shotgun recoils with a momentum equal in magnitude to the momentum of the shot. The recoil velocity of the shotgun will be smaller than the shot's velocity because of the larger mass of the gun, but it is still sizable. As the gun slams back against your shoulder, you will know that it has recoiled.

How can you avoid a bruised shoulder? The trick is to hold the gun firmly against your shoulder. (See example box 7.3.) Your own mass then becomes part of the system. This



**Figure 7.12** The shot and the shotgun have equal but oppositely directed momentums after the gun is fired.

### Example Box 7.3

#### Sample Question: Is Momentum Conserved When Shooting a Shotgun?

**Question:** When a shotgun is held firmly against your shoulder, is the momentum of the system conserved?

**Answer:** It depends on how you define the system. If the system is defined as just the shotgun and the pellets, there is then a strong external force exerted on the system by the shoulder of the shooter. Because the condition for conservation of momentum is that the net external force acting on the system be zero, the momentum of this system is not conserved.

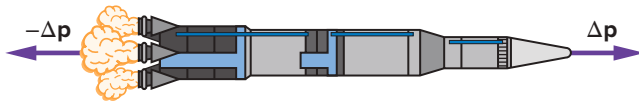
If we included the shooter and the Earth in our system, then momentum would be conserved because all of the forces would be internal to this system. The change in the momentum of the Earth would be imperceptible, however.

increased mass will produce a smaller recoil velocity, even if you happen to be standing on ice with no frictional forces between your feet and the Earth. More important, the shotgun will not move against your shoulder.

### How does a rocket work?

The firing of a rocket is another example of recoil. The exhaust gases rushing out of the tail of the rocket have both mass and velocity and, therefore, momentum. If we ignore external forces, the momentum gained by the rocket in the forward direction will equal in magnitude the momentum of the exhaust gases in the opposite direction (fig. 7.13). Momentum is conserved, just as in our other examples of recoil. The rocket and the exhaust gases push against each other, and Newton's third law applies.

The difference between a rocket and our earlier examples of the skaters and the shotgun is that firing a rocket is usually a continuous process. The rocket gains momentum gradually rather than in a single, short blast. The mass of the



**Figure 7.13** If a short blast is fired, the rocket gains momentum equal in magnitude but opposite in direction to the momentum of the exhaust gases.

rocket also changes as fuel is consumed and gases exhaust from the rocket engines. Computation of the final velocity becomes more difficult than for the skaters. For a brief blast of the rocket, though, the same analysis can be used.

Recoil works in empty outer space: The two objects need only push against each other, just as with the skaters and the shotgun. Rocket engines can be used for space travel, unlike the propeller engines or jet engines used on airplanes. Airplane engines depend on the presence of the atmosphere, both as a source of oxygen used in burning fuel and as something to push against. An airplane propeller pushes against the air, and the air, by Newton's third law, pushes against the propeller. This interaction accelerates the airplane. A rocket, on the other hand, is self-contained. It exerts a force on its own exhaust gases, and by the third law, the exhaust gases exert a force on the rocket.

During recoil, objects push against each other, moving in opposite directions. If external forces can be neglected, momentum is conserved. The total momentum before and after the interaction equals zero. After the interaction, the two objects move away with equal but oppositely directed momentum vectors that cancel each other. Recoil is one of many kinds of brief interaction to which conservation of momentum applies.

## 7.4 Elastic and Inelastic Collisions

As the example involving football players showed, collisions are one of the most fruitful areas for applying conservation of momentum. Collisions involve large forces of interaction acting for very brief times, and they produce dramatic changes in the motion of the colliding objects. Because the forces of interaction are so large, any external forces acting on the system usually are unimportant by comparison: Momentum is conserved.

Different kinds of collisions produce different results. Sometimes the objects stick together and sometimes they bounce apart. What distinguishes these different cases, and what do the terms *elastic*, *inelastic*, and *perfectly inelastic* mean when applied to collisions? Is energy conserved as well as momentum? Railroad cars, bouncing balls, and billiard balls help illustrate the differences.

### What is a perfectly inelastic collision?

The easiest type of collision to analyze is one where two objects collide head-on and stick together after the collision, like the two football players discussed earlier. Because they stuck together and moved as one object after the collision, we had just one final velocity to contend with.

A collision in which the objects stick together after collision is called a **perfectly inelastic collision**. The objects do not bounce at all. If we know the total momentum of the system before the collision (and external forces are ignored), we can readily compute the final momentum and velocity of the now-joined objects.

Coupling railroad cars are another example of this type of collision. Example box 7.4 uses conservation of momentum to predict the final momentum and velocity of coupled railroad cars from knowledge of the momentum of the system before the collision. The process is much the same as the one used to predict the final velocity of the football players in section 7.2. In both cases, the separate objects move as one following the collision.

In example box 7.4, the total mass of the coupled cars after the collision is five times that of car 5, so the final velocity of the coupled cars must be one-fifth that of car 5 to conserve momentum. The momentum of the system immediately after the collision is equal to that just before the collision, but the velocities have changed. The “final” velocity we calculated is valid immediately after the collision. As the cars continue to move following the collision, frictional forces will gradually decelerate them until they come to rest.

### Is energy conserved in collisions?

Is the kinetic energy after the railroad cars collide equal to the original kinetic energy of car 5 in the example in example box 7.4? Using the relationship  $KE = \frac{1}{2}mv^2$  introduced in chapter 6, we can compute the kinetic energy before and after the collision. The original kinetic energy of car 5 is 810 kJ. (A kilojoule, kJ, is a thousand joules.) Immediately after the collision, the kinetic energy of the five cars moving together is just 162 kJ. (You can check these values; see exercise E15.) A portion of the original kinetic energy is lost in any perfectly inelastic collision.

If we put a large spring on the front of the moving railroad car and allowed it to bounce off the other four cars rather than coupling, we will find that a greater portion of the kinetic energy is retained in the collision. When the objects bounce, the collision is either *elastic* or only *partially inelastic*, rather than perfectly inelastic. The distinction is based on energy. An **elastic collision** is one in which *no* energy is lost. A **partially inelastic collision** is one in which *some* energy is lost, but the objects do not stick together. The greatest portion of energy is lost in the *perfectly inelastic collision*, when the objects stick.

### Example Box 7.4

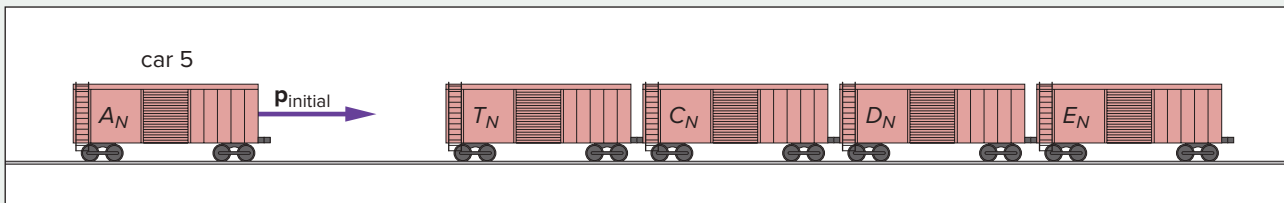
**Sample Exercise: When Railroad Cars Couple**

Four railroad cars, all with the same mass of 20,000 kg, sit on a track, as shown in the drawing. A fifth car of identical mass approaches them with a velocity of 9 m/s (to the right). This car collides and couples with the other four cars.

- What is the initial momentum of the system?
- What is the velocity of the five coupled cars after the collision?

a.  $m_5 = 20,000 \text{ kg}$        $p_{\text{initial}} = m_5 v_5$   
 $v_5 = 9 \text{ m/s}$                $= (20,000 \text{ kg})(9 \text{ m/s})$   
 $p_{\text{initial}} = ?$                  $= \mathbf{180,000 \text{ kg} \cdot \text{m/s}}$   
(before the collision)

b.  $m_{\text{total}} = 100,000 \text{ kg}$        $v_{\text{final}} = \frac{p_{\text{final}}}{m_{\text{total}}}$   
 $p_{\text{final}} = p_{\text{initial}}$                $= \frac{180,000 \text{ kg} \cdot \text{m/s}}{100,000 \text{ kg}}$   
 $v_{\text{final}} = ?$                          $= \mathbf{1.8 \text{ m/s}}$   
(for the five cars after the collision)

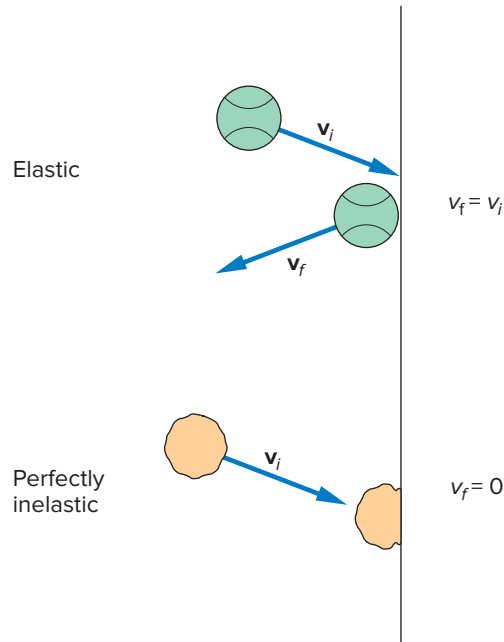


A railroad car approaches four others at rest on the track. What is the velocity of the cars after they couple?

In most collisions, some kinetic energy is lost, because the collisions are not perfectly elastic. Heat is generated, the objects may be deformed, and sound waves are created, all of which involve conversions of the kinetic energy of the objects to other forms of energy. Even if the objects bounce, we cannot assume that the collision is elastic. More likely, the collision will be partially inelastic, implying that some of the initial kinetic energy has been lost.

A ball bouncing off a floor or wall with no decrease in the magnitude of its velocity is an example of an elastic collision. Because the magnitude of the velocity does not change (only the direction changes), the kinetic energy does not decrease. No energy has been lost. More likely, of course, some energy will be lost in such a collision, and the magnitude of the ball's velocity after the collision will be a little smaller than before.

The opposite extreme to an elastic collision of a ball with the wall is a perfectly inelastic collision in which the ball sticks to the wall. In this case, the velocity of the ball after the collision is zero. So is its kinetic energy. All of the kinetic energy is lost (fig. 7.14).



**Figure 7.14** An elastic collision and a perfectly inelastic collision of a ball with a wall. The ball sticks to the wall in the perfectly inelastic collision.

**What happens when billiard balls bounce?**

Very little energy is lost when billiard balls collide with each other. (Time spent playing pool can be justified as a form of experimental physics. Your intuition about elastic collisions

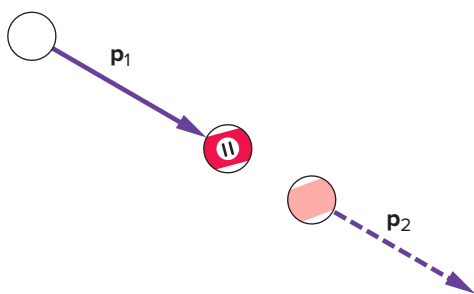
can be improved in the process!) The collisions are basically elastic. Both momentum and kinetic energy are conserved in most collisions of billiard balls.

When colliding objects, such as billiard balls, bounce off each other, we must deal with two final velocities rather than one. We can readily compute the total momentum of the system before and after the collision from our knowledge of the initial momentum values of the objects. More information is needed to determine the individual velocities of the objects after the collision, however, because one value is not enough to determine two unknown velocities. (This is why the case of the perfectly inelastic collision, where objects stick together, is particularly easy to analyze.) In an elastic collision, conservation of energy provides the additional information.

For billiard balls, the simplest case is the white cue ball colliding head-on with a second ball that is not moving before it is hit (the 11 ball in fig. 7.15). What happens? If spin is a minor factor in the collision, the cue ball stops dead on impact, and the 11 ball moves forward with a velocity equal to that of the cue ball before the collision. If the 11 ball acquires the same velocity that the cue ball had before the collision, it also has the same momentum  $m\mathbf{v}$  as the initial momentum of the cue ball, because both balls have the same mass. Momentum is conserved.

Kinetic energy is also conserved. The cue ball had a kinetic energy of  $\frac{1}{2}mv^2$  before the collision. After the collision, the velocity and kinetic energy of the cue ball are zero, but the 11 ball now has a kinetic energy of  $\frac{1}{2}mv^2$ , because its mass and speed are the same as the cue ball before the collision. Given the equal masses of the two balls, the only way that both momentum and kinetic energy can be conserved is for the cue ball to stop and the 11 ball to move forward with the same momentum and kinetic energy that the cue ball had before the collision. This effect is familiar to any pool player.

The same phenomenon is involved in the familiar swinging-ball demonstration often seen as a decorative toy on mantels or desktops (fig. 7.16). A row of steel balls hangs by threads from a metal or wooden frame. If one ball is pulled back and released, the collision with the other balls results in a single ball from the other end of the chain flying off with the same velocity as the first ball just before the collision. Both momentum and kinetic energy are conserved.



**Figure 7.15** A head-on collision between the white cue ball and the 11 ball initially at rest. The cue ball stops, and the 11 ball moves forward.



**Figure 7.16** The swinging-ball apparatus provides an example of collisions that are approximately elastic. *Mike Kemp/RubberBall/SuperStock*

If two balls on one side are pulled back and released, two balls fly off from the opposite side of the row of balls after the collision. Again, both momentum and kinetic energy are conserved by this result. You can explore a variety of other combinations. It can be entertaining as well as addictive.

Collisions between hard spheres, such as billiard balls or the steel balls in the swinging-ball apparatus, will generally be more or less elastic. Most collisions involving everyday objects, though, are inelastic to some degree. Some kinetic energy is lost. Momentum will be conserved, however, as long as our concern is with the values of momentum and velocity immediately before and after the collision.

Conservation of momentum is the primary tool used in understanding collisions. External forces can be ignored for the brief time of the collision, when the collision forces are dominant, and the law of conservation of momentum applies. Kinetic energy can also be conserved if the collision is elastic, as it is approximately for billiard balls or other hard spheres. Most collisions involving familiar objects are partially inelastic and involve some loss of energy. The greatest proportion of energy is lost in perfectly inelastic collisions where objects stick together.

## 7.5 Collisions at an Angle

What happens when objects such as billiard balls or automobiles collide at an angle, rather than head-on? Some interesting applications of conservation of momentum arise when

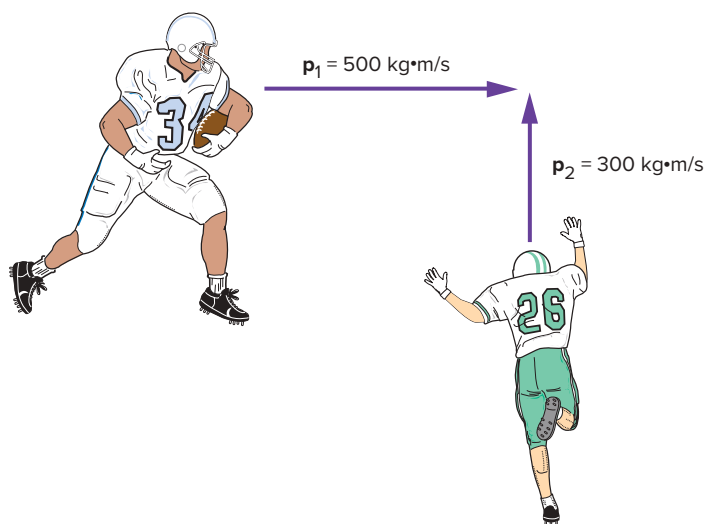
motion is not confined to a straight line. It becomes more apparent that momentum is a vector when objects are free to move in two dimensions. Balls on a pool table, cars colliding at an intersection, and football players tackling one another all provide interesting examples.

### An inelastic, two-dimensional collision

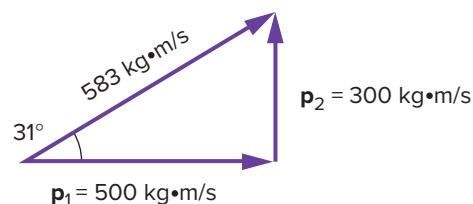
Two football players, originally traveling at right angles to one another, collide and stick together, as in figure 7.17. What will be their direction of motion after the collision? How do we apply conservation of momentum in this two-dimensional case? In figure 7.17, we assume that the two players have the same masses and initial speeds as in our earlier example (section 7.2), but we no longer have a head-on collision. The momentum of the defensive back is now directed across the field as the fullback heads downfield.

Because momentum is a vector, we need to add the individual momentum vectors of the fullback and the defensive back to get the total momentum of the system before the collision. This can be done most readily by using a vector diagram with the vectors drawn to scale. The vectors can then be added graphically, as we have done before. As shown in figure 7.18, the total momentum of the system before the collision is the hypotenuse of the right triangle formed by adding the other two momentum vectors.

If momentum is conserved in the collision, the total momentum of the two players after the collision will equal the total momentum before the collision. Because the two players move together after the collision, they will travel in the direction of the total momentum vector shown in figure 7.18.



**Figure 7.17** The fullback and the defensive back approaching each other at a right angle.



**Figure 7.18** The total momentum of the two football players prior to the collision is the vector sum of their individual momentums.

(See appendix C for a review of vector addition.) The direction of motion of both players changes as a result of the collision. The larger momentum of the fullback before the collision dictates that the final direction of motion is more downfield than across the field, but it is some of both. This result makes intuitive sense if you imagine yourself as one of the players.

The final direction of motion of the two football players after the collision depends on their momentum values before the collision. If the defensive back were bigger or moving faster than we assumed initially, he would have a larger momentum, and his tackle would cause a more impressive change in the direction of the fullback's motion. On the other hand, if the defensive back is small and moving slowly, his effect on the fullback's direction will be small. Adjusting the length of the momentum arrow  $\mathbf{p}_2$ , the momentum of the defensive back in figure 7.18, will illustrate these changes.

Everyday phenomenon box 7.2 describes a similar situation. Two cars approaching an intersection at right angles to one another collide and stick together. Working backward from information about the final direction of travel, the investigator can draw conclusions about the initial velocities of the two cars. Conservation of momentum is extremely important in accident analysis.

### What happens in elastic, two-dimensional collisions?

When billiard balls collide, they do not stick together after the collision: When objects bounce, we have to contend with two final velocities with different directions. Although many real collisions are like this, analysis is more complicated for them than for the perfectly inelastic examples we have discussed. More information is needed to predict the final velocities. If we know that the collision is elastic, however, conservation of kinetic energy can provide that additional information.

Experimental physics on the pool table comes through again with an interesting example (and one of practical value

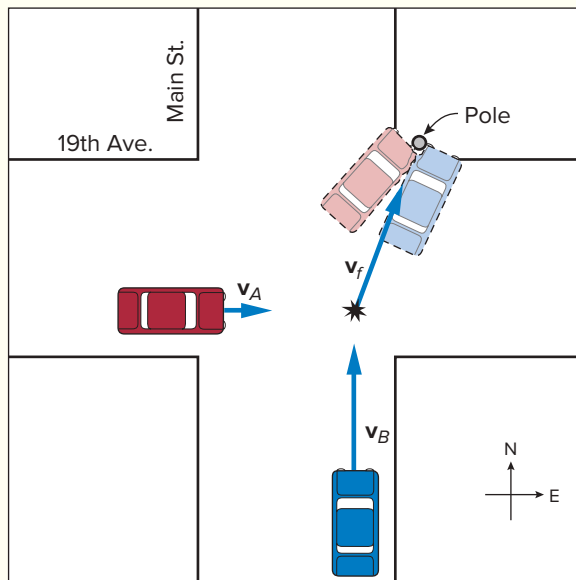
## Everyday Phenomenon

## Box 7.2

## An Automobile Collision

**The Situation.** Officer Jones is investigating an automobile collision at the intersection of Main Street and 19th Avenue. Driver A was traveling east on 19th Avenue when she was struck from the side by driver B, who was traveling north on Main Street. The two cars stuck together after the collision and ended up against the lamppost on the northeast corner of the intersection.

Both drivers claim they started up just as the light in their direction changed to green and then collided with the other driver, who was running a red light and speeding. There are no other witnesses. Which driver is telling the truth?



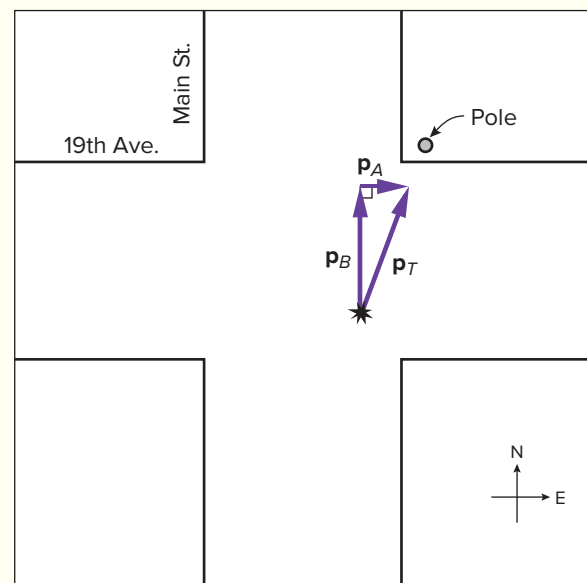
The collision at Main Street and 19th Avenue.

**The Analysis.** Officer Jones, having taken a physics course during college and being trained in the art of accident investigation, makes these observations:

1. The point of impact is well marked by the shards of glass from the headlights of B's car and other debris. Officer Jones indicates this point on the diagram in her accident report form.
2. The direction the two cars are traveling after the impact is also obvious. (She indicated this by a line drawn from the point of impact to the cars' final resting spot.)

3. Both cars have about the same mass (both are compacts of roughly the same vintage and size).
4. Conservation of momentum should determine the direction of the momentum vector after the collision.

After sketching the diagram and noting the direction of the final momentum vector, Officer Jones concludes that B is lying. Why? The final momentum vector must be equal to the sum of the initial momentum vectors of the two cars before the collision. Because the cars were traveling at right angles to one another, the two initial momentum vectors form the sides of a right triangle whose hypotenuse is the total momentum of the system. The diagram clearly shows that the momentum of B's car must have been considerably larger than the momentum of A's car.



Officer Jones's accident report contains a vector diagram derived from conservation of momentum.

Because both drivers claimed to have just started from a complete stop after the traffic signal changed, the driver with the larger velocity before the collision is not telling it like it was. Driver B is the one who had the larger velocity and, so, was presumably speeding through the red light. Driver B is thus cited by Officer Jones.

to any pool player). Suppose the cue ball strikes the stationary 11 ball at an angle (off-center), as in figure 7.19. What happens to the two balls after the collision? The combined effects of conservation of momentum and conservation of kinetic energy lead to a unique result well known to serious pool players.

The initial momentum of the system is simply that of the cue ball, the only one moving. Its direction is indicated by the arrow labeled  $\mathbf{p}_i$  in figure 7.19 and in the drawings in figure 7.20. The force of interaction (and the impulse) between the two balls is along a line joining the centers of the balls at the point of impact. The 11 ball moves off along this line because the force of contact pushes it in that direction.

The total momentum of the system after the collision must still be in the direction of the initial momentum, because momentum is conserved in the collision. Conservation of momentum also restricts the possible momentum and direction of the cue ball's motion after the collision (fig. 7.20). The momentum vectors of the two balls after the collision are added here to give the total momentum of the system,  $\mathbf{p}_{\text{total}}$ , which must be equal in both magnitude and direction to the initial momentum of the system.

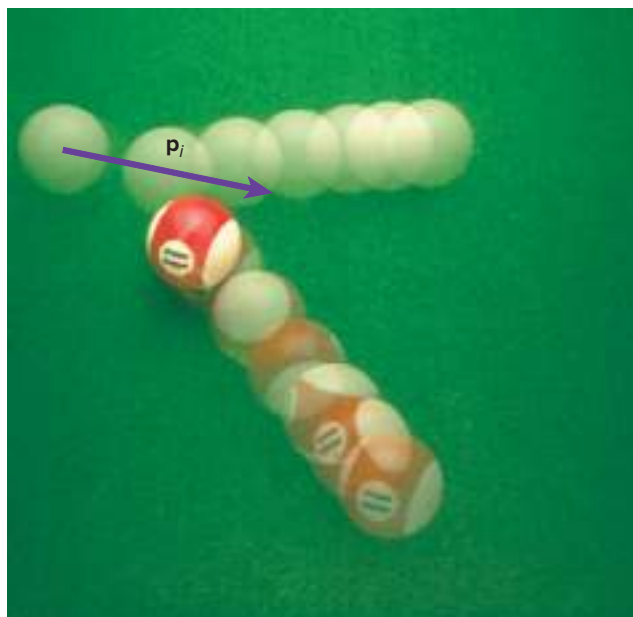
Because the collision is elastic, the initial kinetic energy of the cue ball,  $\frac{1}{2}mv^2$ , must also equal the sum of the kinetic energies of the two balls afterward. Because the masses of the two balls are equal, conservation of kinetic energy in the collision requires that\*

$$v^2 = (v_1)^2 + (v_2)^2$$

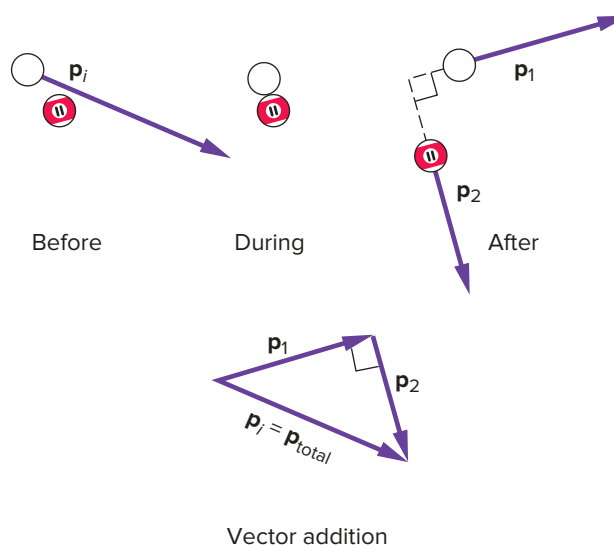
where  $v$  is the speed of the cue ball before the collision, and  $v_1$  and  $v_2$  are the speeds of the two balls afterward. The velocity vectors form a triangle like the one formed by the momentum vectors in figure 7.20. If the sum of the squares of the two sides equals the square of the third side of the triangle, this triangle must be a right triangle, according to the Pythagorean theorem from plane geometry. If the velocity vectors form a right triangle, so do the momentum vectors, which have the same directions as the corresponding velocity vectors.

Conservation of momentum requires that the momentum vectors add to form a triangle, but conservation of kinetic energy dictates that it be a *right* triangle. The cue ball will move off at a right angle ( $90^\circ$ ) to the direction of motion of the 11 ball after the collision. In playing pool, this is an important piece of intelligence if you are planning your next shot. Conservation of momentum *and* conservation of kinetic energy determine the shot.

If you have a pool table handy, test these conclusions using a variety of impact angles. (Marbles or steel balls are a suitable substitute.) You may not get perfect  $90^\circ$  angles



**Figure 7.19** The cue ball is aimed at a point off-center on the second ball to produce an angular collision. *Richard Megna/Fundamental Photographs, NYC*



**Figure 7.20** The momentum vectors of the two balls after the collision add to give the total (initial) momentum of the system. The paths of the two balls are approximately at right angles after the collision.

after the collision: The collision is not perfectly elastic, and spin can sometimes be a factor. The angle between the two final velocities, though, will usually be within a few degrees of a right angle. Seeing is believing, however, so give it a try.

\*Conservation of kinetic energy requires that  $\frac{1}{2}mv^2 = \frac{1}{2}m(v_1)^2 + \frac{1}{2}m(v_2)^2$ , but the mass and the factor of  $\frac{1}{2}$  can be divided out of the equation.

Conservation of momentum requires that the direction of the momentum vector be conserved, as well as its size. When collisions occur at an angle, this requirement restricts the directions and velocities of the resulting motions. If the collision is elastic, as with billiard balls, conservation of energy adds another restriction. If you can imagine the direction and magnitude of the original momentum vector, you will have some sense of the outcome. These conservation laws are powerful predictors of what happens when people, billiard balls, cars, and even subatomic particles or stars collide.

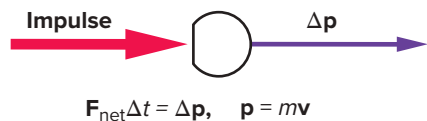
### Debatable Issue

Statistics on automobile accidents provide convincing evidence that the use of seat belts (with shoulder harnesses) reduces the number of serious injuries and fatalities in automobile accidents. On the other hand, there are some cases in which being thrown from a car in an accident actually improves your chances of survival—if the car catches fire, for example. Given this, should individuals be able to choose not to use seat belts without legal consequences?

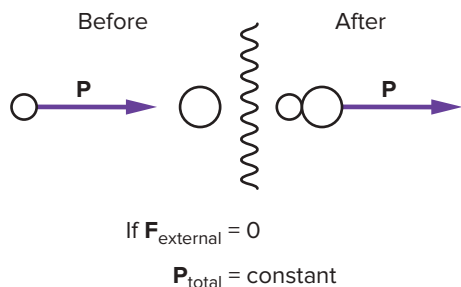
## Summary

In this chapter, we recast Newton’s second law in terms of impulse and momentum to describe interactions between objects, such as collisions, that involve strong interaction forces acting over brief time intervals. The principle of conservation of momentum, which follows from Newton’s second and third laws, plays a central role.

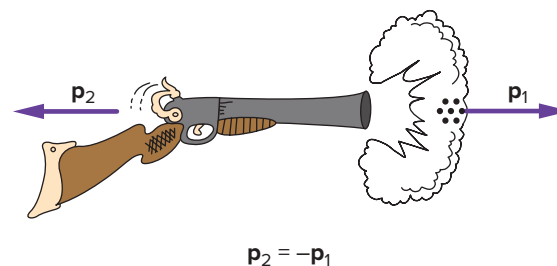
**1 Momentum and impulse.** Newton’s second law can be recast in terms of momentum and impulse, yielding the statement that the net impulse acting on an object equals the change in momentum of the object. Impulse is defined as the average force acting on an object multiplied by the time interval during which the force acts. Momentum is defined as the mass of an object times its velocity.



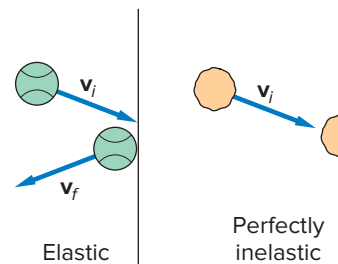
**2 Conservation of momentum.** Newton’s second and third laws combine to yield the principle of conservation of momentum: If the net external force acting on a system is zero, the total momentum of the system is a constant.



**3 Recoil.** If an explosion or push occurs between two objects initially at rest, conservation of momentum dictates that the total momentum after the event must still be zero if there is no net external force. The final momentum vectors of the two objects are equal in size but opposite in direction.

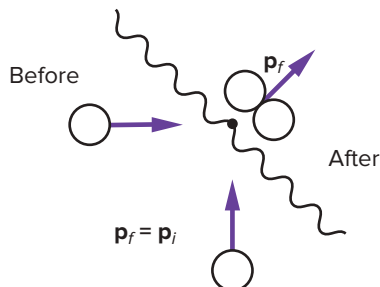


**4 Elastic and inelastic collisions.** A perfectly inelastic collision is one in which the objects stick together after the collision. If external forces can be ignored, the total momentum is conserved. An elastic collision is one in which the total kinetic energy is also conserved.





**5 Collisions at an angle.** Conservation of momentum is not restricted to one-dimensional motion. When objects collide at an angle, the total momentum of the system before and after the collision is found by adding the momentum vectors of the individual objects.



Impulse and momentum are evident in so many everyday phenomena. It is easy to become confused about which properties stay the same and which change, especially in collisions. The study hints in Connect should help clarify these ideas.

## Key Terms

Impulse, 126

Linear momentum, 126

Impulse-momentum principle, 127

Conservation of momentum, 128

Recoil, 132

Perfectly inelastic collision, 133

Elastic collision, 133

Partially inelastic collision, 133

## Study Hint

Except for the examples involving impulse, most of the situations described in this chapter highlight the principle of conservation of momentum. The basic ideas used in applying conservation of momentum are these:

1. External forces are assumed to be much smaller than the very strong forces of interaction in a collision or other brief event. If external forces acting on the system can be ignored, momentum is conserved.
2. The total momentum of the system before the collision or other brief interaction  $\mathbf{p}_{\text{initial}}$  is equal to the momentum after the event  $\mathbf{p}_{\text{final}}$ . Momentum is conserved and does not change.
3. Equality of momentum before and after the event can be used to obtain other information about the motion of the objects.

For review, look back at how these three points are used in each of the examples in this chapter. The total momentum of the system before and after the event is always found by adding the momentum values of the individual objects as *vectors*. You should be able to describe the magnitude and direction of this total momentum for each of the examples.

## Conceptual Questions

\* = more open-ended questions, requiring lengthier responses, suitable for group discussion

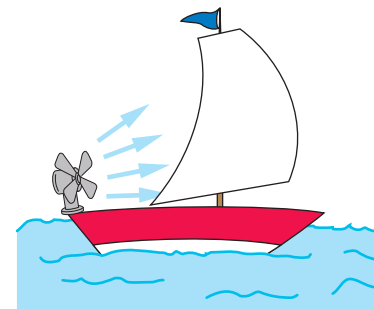
Q = sample responses are available in appendix D

Q = sample responses are available in Connect

- Q1. Does the length of time that a force acts on an object have any effect on the strength of the impulse produced? Explain.
- Q2. Two forces produce equal impulses, but the second force acts for a time twice that of the first force. Which force, if either, is larger? Explain.
- Q3. Is it possible for a baseball to have as large a momentum as a much more massive bowling ball? Explain.
- Q4. Are impulse and force the same thing? Explain.
- Q5. Are impulse and momentum the same thing? Explain.
- Q6. If a ball bounces off a wall so that its velocity coming back has the same magnitude it had prior to bouncing,
  - a. Is there a change in the momentum of the ball? Explain.
  - b. Is there an impulse acting on the ball during its collision with the wall? Explain.
- Q7. Is there an advantage to following through when hitting a baseball with a bat, thereby maintaining a longer contact between the bat and the ball? Explain.
- Q8. What is the advantage of a padded dashboard compared to a rigid dashboard in reducing injuries during collisions? Explain using momentum and impulse ideas.

- Q9.** What is the advantage of an air bag in reducing injuries during collisions? Explain using impulse and momentum ideas.
- \*Q10.** If an air bag inflates too rapidly and firmly during a collision, it can sometimes do more harm than good in low-velocity collisions. Explain using impulse and momentum ideas.
- Q11.** If you catch a baseball or softball with your bare hand, will the force exerted on your hand by the ball be reduced if you pull your arm back during the catch? Explain. (See everyday phenomenon box 7.1.)
- Q12.** Suppose you move your hand forward to meet the egg when performing the egg-toss game. Will this be more or less likely to break the egg than moving your hand backward? Explain. (See everyday phenomenon box 7.1.)
- Q13.** A truck and a bicycle are moving side by side with the same velocity. Which, if either, will require the larger impulse to bring it to a halt? Explain.
- Q14.** Is the principle of conservation of momentum always valid, or are there special conditions necessary for it to be valid? Explain.
- Q15.** A ball is accelerated down a fixed inclined plane under the influence of the force of gravity. Is the momentum of the ball conserved in this process? Explain.
- Q16.** Two objects collide under conditions where momentum is conserved. Is the momentum of each object conserved in the collision? Explain.
- Q17.** Which of Newton's laws of motion are involved in justifying the principle of conservation of momentum? Explain.
- \*Q18.** A compact car and a large truck have a head-on collision. During the collision, which vehicle, if either, experiences
- The greater force of impact? Explain.
  - The greater impulse? Explain.
  - The greater change in momentum? Explain.
  - The greater acceleration? Explain.
- Q19.** A fullback collides midair and head-on with a lighter defensive back. If the two players move together following the collision, is it possible that the fullback will be carried backward? Explain.
- Q20.** Two ice skaters, initially at rest, push off one another. What is the total momentum of the system after they push off? Explain.
- Q21.** Two shotguns are identical in every respect (including the size of shell fired) except that one has twice the mass of the other. Which gun will tend to recoil with greater velocity when fired? Explain.
- \*Q22.** When a cannon rigidly mounted on a large boat is fired, is momentum conserved? Explain, being careful to clearly define the system being considered.
- Q23.** Is it possible for a rocket to function in empty space (in a vacuum) where there is nothing to push against except itself? Explain.
- Q24.** Suppose you are standing on a surface that is so slick you can get no traction at all in order to begin moving across this surface. Fortunately, you are carrying a bag of oranges. Explain how you can get yourself moving.

- Q25.** Suppose an astronaut in outer space suddenly discovers that the tether connecting her to the space station is cut and she is slowly drifting away from the shuttle. Assuming that she is wearing a tool belt holding several wrenches, how can she move herself back toward the space station? Explain.
- \*Q26.** Suppose that on a perfectly still day, a sailboat enthusiast decides to bring along a powerful battery-operated fan in order to provide an air current for his sail, as shown in the diagram.
- What are the directions of the change in momentum of the air at the fan and at the sail?
  - What are the directions of the forces acting on the fan and on the sail due to these changes in momentum?
  - Would the sailor be better off with the sail furled (down) or unfurled (up)? Explain.



**Q26 Diagram**

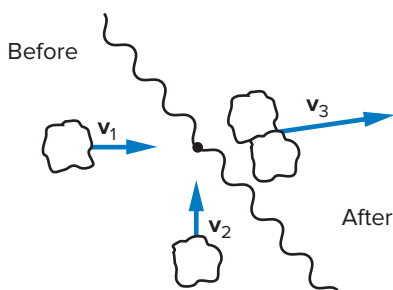
- Q27.** A skateboarder jumps on a moving skateboard from the side. Does the skateboard slow down or speed up in this process? Explain, using conservation of momentum.
- Q28.** A railroad car collides and couples with a second railroad car that is standing still. If external forces acting on the system are ignored, is the velocity of the system after the collision equal to, greater than, or less than that of the first car before the collision? Explain.
- Q29.** Is the collision in question 28 elastic, partially inelastic, or perfectly inelastic? Explain.
- Q30.** If momentum is conserved in a collision, does this indicate conclusively that the collision is elastic? Explain.
- Q31.** A ball bounces off a wall with a velocity whose magnitude is less than it was before hitting the wall. Is the collision elastic? Explain.
- Q32.** A ball bounces off a wall that is rigidly attached to the Earth.
- Is the momentum of the ball conserved in this process? Explain.
  - Is the momentum of the entire system conserved? Explain, being careful to clarify how you are defining the system.
- Q33.** A cue ball strikes an 8 ball of equal mass, which is initially at rest. The cue ball stops and the 8 ball moves forward with a velocity equal to the initial velocity of the cue ball. Is the collision elastic? Explain.

Q34. Two lumps of clay traveling through the air in opposite directions collide and stick together. Their momentum vectors prior to the collision are shown in the diagram. Sketch the momentum vector of the combined lump of clay after the collision, making the length and direction appropriate to the situation. Explain your result.



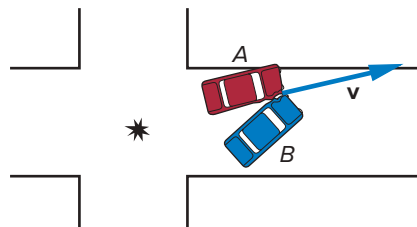
Q34 Diagram

Q35. Two lumps of clay, of equal mass, are traveling through the air at right angles to each other with velocities of equal magnitude. They collide and stick together. Is it possible that their velocity vector after the collision is in the direction shown in the diagram? Explain.



Q35 Diagram

Q36. Two cars of equal mass collide at right angles to each other in an intersection. Their direction of motion after the collision is as shown in the diagram. Which car had the greater velocity before the collision? Explain. (See everyday phenomenon box 7.2.)



Q36 Diagram

Q37. A car and a small truck traveling at right angles to each other with the same speed collide and stick together. The truck's mass is roughly twice the car's mass. Sketch the direction of their momentum vector immediately after the collision. Explain your result. (See everyday phenomenon box 7.2.)

\*Q38. A cue ball strikes a glancing blow against a second billiard ball initially at rest. Sketch the situation, indicating the magnitudes and directions of the momentum vectors of each ball before and after the collision.

## Exercises

- E1. An average force of 4800 N acts for a time interval of 0.003 s on a golf ball.
  - a. What is the magnitude of the impulse acting on the golf ball?
  - b. What is the change in the golf ball's momentum?
- E2. What is the momentum of a 1300-kg car traveling with a speed of 27 m/s (60 MPH)?
- E3. A bowling ball has a mass of 7 kg and a speed of 1.5 m/s. A major league baseball has a mass of 0.142 kg and a speed of 40 m/s. Which ball has the larger momentum?
- E4. A force of 128 N acts on a ball for 0.45 s. If the ball is initially at rest,
  - a. What is the impulse on the ball?
  - b. What is the final momentum of the ball?
- E5. A 0.14-kg ball traveling with a speed of 40 m/s is brought to rest in a catcher's mitt. What is the size of the impulse exerted by the mitt on the ball?
- E6. A ball experiences a change in momentum of 64 kg·m/s.
  - a. What is the impulse acting on the ball?
  - b. If the time of interaction is 0.15 s, what is the magnitude of the average force acting on the ball?
- E7. A 75-kg front-seat passenger in a car moving initially with a speed of 23 m/s (50 MPH) is brought to rest by an air bag in a time of 0.3 s.
  - a. What is the impulse acting on the passenger?
  - b. What is the average force acting on the passenger in this process?
- E8. A ball traveling with an initial momentum of 1.7 kg·m/s bounces off a wall and comes back in the opposite direction with a momentum of  $-1.7$  kg·m/s.
  - a. What is the change in momentum of the ball?
  - b. What impulse would be required to produce this change?
- E9. A ball traveling with an initial momentum of 5.1 kg·m/s bounces off a wall and comes back in the opposite direction with a momentum of  $-4.3$  kg·m/s.
  - a. What is the change in momentum of the ball?
  - b. What impulse is required to produce this change?
- E10. A fullback with a mass of 108 kg and a velocity of 3.2 m/s due north collides head-on with a defensive back with a mass of 79 kg and a velocity of 5.6 m/s due south.
  - a. What is the initial momentum of each player?
  - b. What is the total momentum of the system before the collision?
  - c. If they stick together and external forces can be ignored, what direction will they be traveling immediately after they collide?
- E11. An ice skater with a mass of 70 kg pushes off against a second skater with a mass of 30 kg. Both skaters are initially at rest.
  - a. What is the total momentum of the system after they push off?
  - b. If the larger skater moves off with a speed of 2.8 m/s, what is the corresponding speed of the smaller skater?

- E12. A rifle with a mass of 3.4 kg fires a bullet with a mass of 7.8 g (0.0078 kg). The bullet moves with a muzzle velocity of 860 m/s after the rifle is fired.
- What is the momentum of the bullet after the rifle is fired?
  - If external forces acting on the rifle can be ignored, what is the recoil velocity of the rifle?
- E13. A rocket ship at rest in space gives a short blast of its engine, firing 60 kg of exhaust gas out the back end with an average velocity of 450 m/s. What is the change in momentum of the rocket during this blast?
- E14. A railroad car with a mass of 13,000 kg collides and couples with a second car of mass 20,000 kg that is initially at rest. The first car is moving with a speed of 3.5 m/s prior to the collision.
- What is the initial momentum of the first car?
  - If external forces can be ignored, what is the final velocity of the two railroad cars after they couple?
- E15. For the railroad cars in example box 7.4,
- What is the kinetic energy of car 5 before the collision?
  - What is the kinetic energy of all five cars just after the collision?
  - Is energy conserved in this collision?
- E16. A 4150-kg truck traveling with a velocity of 12 m/s due east collides head-on with a speeding 900-kg car traveling with a velocity of 40 m/s due west. The two vehicles stick together after the collision.
- What is the momentum of each vehicle prior to the collision?
  - What are the size and direction of the total momentum of the two vehicles after they collide?
- E17. For the two vehicles in exercise E16,
- Sketch to scale the momentum vectors of the two vehicles prior to the collision.
  - Add the two vectors on your sketch graphically.
- E18. A car with a mass of 1600 kg traveling with a speed of 25 m/s collides at right angles with a truck with a mass of 3000 kg traveling with a speed of 10 m/s.
- Sketch to proper scale and direction the momentum vector of each vehicle prior to the collision.
  - Using the graphical method of vector addition, add the momentum vectors to get the total momentum of the system prior to the collision.
- E19. Refer to example box 7.2 and figures 7.17 and 7.18. Assume you have a fullback with a mass of 100 kg and an initial velocity of 5.0 m/s, heading due east. A defensive back has a mass of 75 kg and an initial momentum of 4.0 m/s, heading due north. They collide and stick together, with a final momentum of 583 kg m/s, as shown in figure 7.18.
- What is the final speed, after the collision, of the two football players?
  - How does this compare to the final speed for the head-on collision computed in example box 7.2?

## Synthesis Problems

- SP1. A fast ball thrown with a velocity of 40 m/s (approximately 90 MPH) is struck by a baseball bat, and a line drive comes back toward the pitcher with a velocity of 65 m/s. The ball is in contact with the bat for a time of just 0.005 s. The baseball has a mass of 142 g (0.142 kg).
- What is the change in momentum of the baseball during this process?
  - Is the change in momentum greater than the final momentum? Explain.
  - What is the magnitude of the impulse required to produce this change in momentum?
  - What is the magnitude of the average force that acts on the baseball to produce this impulse?
- SP2. A bullet is fired into a block of wood sitting on a block of ice. The bullet has an initial velocity of 800 m/s and a mass of 0.007 kg. The wooden block has a mass of 1.3 kg and is initially at rest. The bullet remains embedded in the block of wood afterward.
- Assuming that momentum is conserved, find the velocity of the block of wood and bullet after the collision.
  - What is the magnitude of the impulse that acts on the block of wood in this process?
  - Does the change in momentum of the bullet equal that of the block of wood? Explain.
- SP3. Consider two cases in which the same ball is thrown against a wall with the same initial velocity. In case A, the ball sticks to the wall and does not bounce. In case B, the ball bounces back with the same speed it came in with.
- In which of these two cases is the change in momentum the largest?
  - Assuming that the time during which the momentum change takes place is approximately the same for these two cases, in which case is the larger average force involved?
  - Is momentum conserved in this collision? Explain.
- SP4. A car traveling at a speed of 22 m/s (approximately 50 MPH) crashes into a solid concrete wall. The driver has a mass of 80 kg.
- What is the change in momentum of the driver as he comes to a stop?
  - What impulse is required in order to produce this change in momentum?
  - How do the application and magnitude of this force differ in two cases: the first, in which the driver is wearing a seat belt, and the second, in which he is not wearing a seat belt and is stopped instead by contact with the windshield and steering column? Will the time of action of the stopping force change? Explain.

- SP5. A 1600-kg car traveling due east with a speed of 30 m/s collides head-on with a 4800-kg truck traveling due west with a speed of 15 m/s. The two vehicles stick together after the collision.
- What is the total momentum of the system prior to the collision?
  - What is the velocity of the two vehicles just after the collision?
  - What is the total kinetic energy of the system before the collision?
  - What is the total kinetic energy just after the collision?
  - Is the collision elastic? Explain.

## Home Experiments and Observations

- HE1. Take two marbles or steel balls of the same size and practice shooting one into the other. Make these observations:
- If you produce a head-on collision with the second marble initially at rest, does the first marble come to a complete stop after the collision?
  - If the collision with a second marble occurs at an angle, is the angle between the paths of the two marbles after the collision a right angle ( $90^\circ$ )?
  - If marbles of different sizes and masses are used, how do the results of parts a and b differ from those obtained with marbles of the same mass?
- HE2. If you have access to a pool table, try parts a and b of the observations in home experiment 1 on the pool table. What effect does putting spin on the first ball have on the collisions?
- HE3. If you have both a basketball and a tennis ball, try dropping the two of them onto a floor with a hard surface, first individually and then with the tennis ball placed on top of the basketball before the two are dropped together.
- Compare the height of the bounce of each ball in these different cases. The case where the two are dropped together may surprise you.
  - Can you devise an explanation for these results using impulse and Newton's third law? (Consider the force between the basketball and the floor, as well as that between the tennis ball and the basketball for the case where they are dropped together.)
- HE4. Place a cardboard box on a smooth tile or wood floor. Practice rolling a basketball or soccer ball at different speeds and allowing the ball to collide with the box. Observe the motion of both the box and the ball just after the collision.
- How do the results of the collision vary for different speeds of the ball (slow, medium, fast)?
  - If we increase the weight of the box by placing books inside, how do the results of the collision change for the cases in part a?
  - Can you explain your results using conservation of momentum?

# CHAPTER 8



JONDO/Getty Images

## Rotational Motion of Solid Objects

### Chapter Overview

Starting with a merry-go-round—and making use of the analogy between linear and rotational motion—we first consider what concepts are needed to describe rotational motion. We then turn to the causes of rotational motion, which involve a modified form of Newton's second law. Torque, rotational inertia, and angular momentum are introduced as we proceed. Our goal is to develop a clear picture of both the description and the causes of rotational motion. After studying this chapter, you should be able to predict what will happen in many common examples of spinning or rotating objects, such as ice skaters and divers. The world of sports is rich in examples of rotational motion.

### Chapter Outline

- 1 What is rotational motion?** How can we describe rotational motion? What are rotational velocity and acceleration, and how are they related to similar concepts used to describe linear motion?
- 2 Torque and balance.** What determines whether a simple object, such as a balance beam, will rotate? What is torque, and how is it involved in causing an object to rotate?
- 3 Rotational inertia and Newton's second law.** How can Newton's second law be adapted to explain the motion of rotating objects? How do we describe rotational inertia, an object's resistance to changes in rotational motion?
- 4 Conservation of angular momentum.** What is angular momentum, and when is it conserved? How do spinning skaters or divers change their rotational velocities?
- 5 Riding a bicycle and other amazing feats.** Why does a bicycle remain upright when it is moving but not when it is stationary? Can we treat rotational velocity and angular momentum as vectors?

In neighborhood parks, there are often child-propelled merry-go-rounds, as shown in figure 8.1. A merry-go-round consists of a circular steel platform mounted on an excellent bearing, so that it rotates without much frictional resistance. Once set in rotation, it will continue to rotate. Even a child can start it moving and then jump on (and sometimes fall off). Along with the swings, the slide, and the little animals mounted on heavy-duty springs, the merry-go-round is a popular center of activity in the park.

The motion of a merry-go-round bears both similarities and differences to motions we have already considered. A child sitting on the merry-go-round experiences circular motion, so some of the ideas discussed in chapter 5 come into play. What about the merry-go-round itself, though? It certainly moves, but it goes nowhere. How do we describe its motion?

Rotational motion of solid objects, such as the merry-go-round, is common: The rotating Earth, a spinning skater, a top, and a turning wheel all exhibit this type of motion. For Newton's theory of motion to be broadly useful, it should explain what is happening in rotational motion as well as in linear motion (an object moves from one point to another in a straight line). What causes rotational motion? Can Newton's second law be used to explain such motion?

We will find that there is a useful analogy between the linear motion of objects and rotational motion. The questions



**Figure 8.1** A merry-go-round is an example of rotational motion. How do we describe and explain this motion?

*SuperStock Inc.*

just posed can be answered best by making full use of this analogy. Taking advantage of the similarities between rotational motion and linear motion saves space in our mental computers, thus making the learning process more efficient.

## 8.1 What Is Rotational Motion?

A child begins to rotate the merry-go-round described in the introduction. She does so by holding on to one of the bars on the edge of the merry-go-round as she stands beside it. She begins to push the merry-go-round, accelerating as she goes, until eventually she is running, and the merry-go-round is rotating quite rapidly.

How do we describe the rotational motion of the merry-go-round or that of a spinning ice skater? What quantities would we use to describe how fast they are rotating or how far they have rotated?

### Rotational displacement and rotational velocity

How would you measure how fast the merry-go-round is rotating? If you stood to one side and watched the child pass your position, you could count the number of revolutions the child made in a given time, measured with your watch. Dividing the number of revolutions by the time in minutes yields the average rotational speed in revolutions per minute (rpm), a commonly used unit for describing the rate of rotation of motors, Ferris wheels, and other rotating objects.

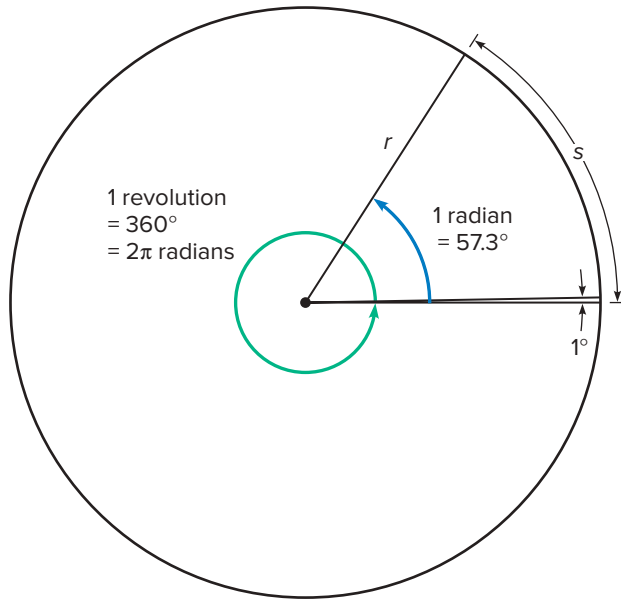
If you say that the merry-go-round rotates at a rate of 15 rpm, you have described how fast an object is turning. The rate is analogous to speed or velocity, quantities used to describe how fast an object is moving in the case of linear motion. We usually use the term **rotational velocity** to

describe this rate of rotation. Revolutions per minute is just one of several units used to measure this quantity.

In measuring the rotational velocity of the merry-go-round, we describe how far it rotates in revolutions or complete cycles. Suppose that an object rotates less than one complete revolution. We can then use a fraction of a revolution to describe how far it has turned, but we might also use an angle measured in degrees. Because there are  $360^\circ$  in one complete revolution or full circle, revolutions can be converted to degrees by multiplying by  $360^\circ/\text{rev}$ .

The quantity measuring how far an object has turned or rotated is an angle, often called the **rotational displacement**. It can be measured in revolutions, degrees, or a simple but less familiar unit called the **radian**.<sup>\*</sup> The three units commonly used to describe rotational displacement are summarized in figure 8.2. Rotational displacement is analogous to the distance traveled by an object in linear motion. If we include the direction of travel, this linear distance, which we discussed in chapter 2, is sometimes called the **linear displacement**.

<sup>\*</sup>The radian is defined by dividing the arc length through which the point travels by the radius of the circle on which it is moving. Thus, in figure 8.2, if the point on the merry-go-round moves along the arc length a distance  $s$ , the number of radians involved is  $s/r$ , where  $r$  is the radius. Because we are dividing one distance by another, the radian itself has no dimensions. Also, because the arc length  $s$  is proportional to the radius  $r$ , it does not matter how large a radius we choose. The ratio of  $s$  to  $r$  will be the same for a given angle. By definition of the radian, 1 revolution (rev) =  $360^\circ = 2\pi$  radians, and 1 radian (rad) =  $57.3^\circ$ .



**Figure 8.2** Revolutions, degrees, and radians are different units for describing the rotational displacement of the merry-go-round.

The symbols used to describe rotational quantities mainly come from the Greek alphabet. Greek letters are used to avoid confusion with other quantities represented by letters of our ordinary Roman alphabet. The Greek letter theta ( $\theta$ ) is commonly used to represent angles (rotational displacements), and the Greek letter omega ( $\omega$ ) is used to represent rotational velocities.

The quantities we have just introduced for describing the motion of an object such as the merry-go-round can be summarized as follows:

Rotational displacement  $\theta$  is an angle showing how far an object has rotated.

Also,

Rotational velocity  $\omega$  is the rate of change of rotational displacement. It is found by dividing the change in the rotational displacement by the time taken for this displacement to happen:

$$\omega = \frac{\Delta\theta}{t}$$

In describing rotational velocity, we usually use either revolutions or radians as the measure of rotational displacement. Degrees are less commonly used. Example box 8.1 shows the conversion between revolutions per minute (rpm), radians per minute, and radians per second.

## Example Box 8.1

### Sample Exercise: Using Radians

Suppose an object has a rotational velocity of 33 revolutions per minute.

- What is the rotational velocity in radians/minute?
- What is the rotational velocity in radians/second?

a.

$$\omega = 33 \frac{\text{rev}}{\text{min}}$$

$$1 \text{ rev} = 2\pi \text{ radians}$$

$$\omega = 33 \frac{\text{rev}}{\text{min}} \times \frac{2\pi \text{ radians}}{1 \text{ rev}} = 66\pi \frac{\text{radians}}{\text{min}} = 207.3 \frac{\text{radians}}{\text{min}}$$

b.

$$\omega = 207.3 \frac{\text{radians}}{\text{min}}$$

$$1 \text{ min} = 60 \text{ sec}$$

$$\omega = 207.3 \frac{\text{radians}}{\text{min}} \times \frac{1 \text{ min}}{60 \text{ sec}} = 3.5 \frac{\text{radians}}{\text{sec}}$$

Lines drawn through the units indicate cancellation.

## What is rotational acceleration?

In our original description of the child pushing the merry-go-round, the rate of rotation increased as she ran alongside. This involves a *change* in the rotational velocity, which suggests the concept of **rotational acceleration**. The Greek letter alpha ( $\alpha$ ) is the symbol used for rotational acceleration. It is the first letter in the Greek alphabet and corresponds to the letter *a*, used to represent linear acceleration.

Rotational acceleration can be defined similarly to linear acceleration (see chapter 2):

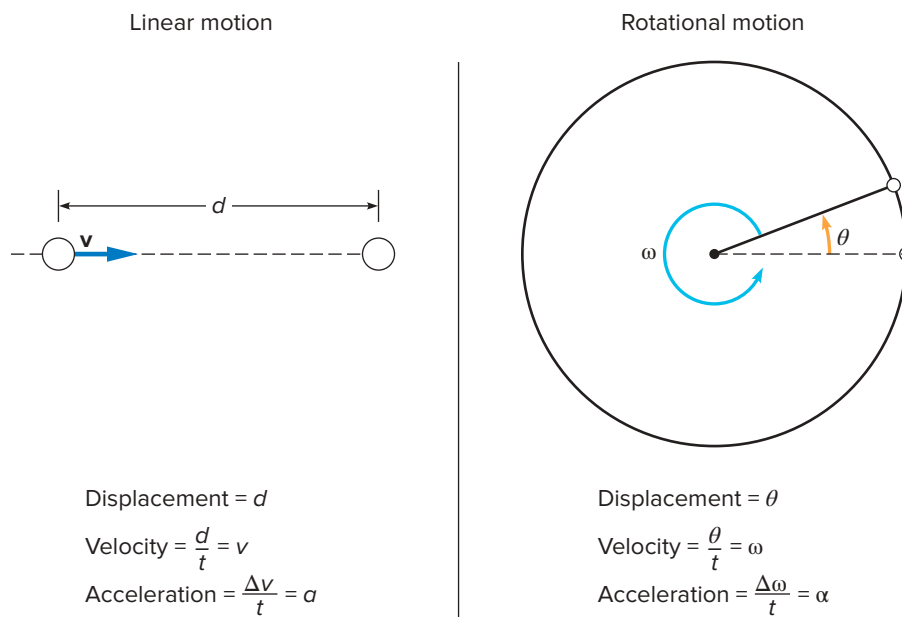
Rotational acceleration is the rate of change in rotational velocity. It is found by dividing the change in rotational velocity by the time required for this change to occur,

$$\alpha = \frac{\Delta\omega}{t}$$

The units of rotational acceleration are  $\text{rev/s}^2$  and  $\text{rad/s}^2$ .

These definitions for both rotational velocity and rotational acceleration actually yield the *average* values of these quantities. To get *instantaneous* values, the time interval  $t$  must be made very small, as in the linear-motion definitions of instantaneous velocity and instantaneous acceleration (see sections 2.2 and 2.3). This then yields the rate of change of either displacement or velocity at a given instant in time.





**Figure 8.3** There is a close resemblance between quantities used to describe linear motion and those used to describe rotational motion.

You will remember these definitions of rotational displacement, velocity, and acceleration better if you keep in mind the complete analogy that exists between linear and rotational motion. This analogy is summarized in figure 8.3. In one dimension, distance  $d$  represents the change in position or *linear* displacement, which corresponds to *rotational* displacement  $\theta$ . Average velocity and acceleration for linear motion are defined as before, with the corresponding definitions of rotational velocity and acceleration shown on the right side of the diagram in figure 8.3.

### Constant rotational acceleration

In chapter 2, we introduced equations for the special case of constant linear acceleration because of its many important applications. By comparing linear and rotational quantities, we can write similar equations for constant rotational acceleration by substituting the rotational quantities for the corresponding linear quantities in the equations developed for linear motion. Table 8.1 shows the results beside corresponding equations for linear motion. Just as  $v_0$  represents the initial linear velocity,  $\omega_0$  refers to the initial angular

velocity. Example box 8.2 is an application of the equations for constant rotational acceleration.

The merry-go-round in example box 8.2 starts from rest and rotates through nine complete revolutions in 1 minute, a good effort by the person pushing. It is unlikely this rate of acceleration could be sustained much longer than 1 minute. The rotational velocity reached in this time is a little less than a third of a revolution per second, a fast rotational velocity for such a merry-go-round.

### Example Box 8.2

#### Sample Exercise: Rotating a Merry-Go-Round

Suppose a merry-go-round is accelerated at a constant rate of  $0.005 \text{ rev/s}^2$ , starting from rest.

- What is its rotational velocity at the end of 1 min?
- How many revolutions does the merry-go-round make in this time?

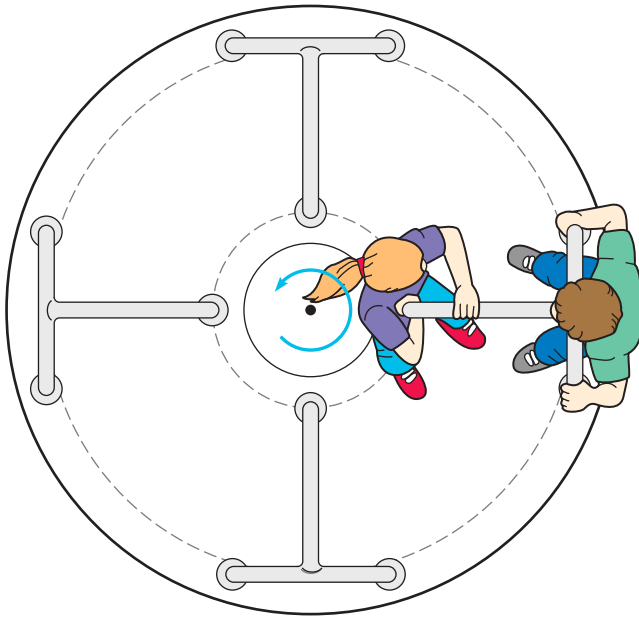
**a.**  $\alpha = 0.005 \text{ rev/s}^2$        $\omega = \omega_0 + \alpha t$   
 $\omega_0 = 0$                                $= 0 + (0.005 \text{ rev/s}^2)(60 \text{ s})$   
 $t = 60 \text{ s}$                                $= \mathbf{0.30 \text{ rev/s}}$

**b.**  $\theta = ?$                               Since  $\omega_0$  is equal to zero,  
 $\theta = \frac{1}{2} \alpha t^2$   
 $= \frac{1}{2} (0.005 \text{ rev/s}^2)(60 \text{ s})^2$   
 $= \mathbf{9 \text{ rev}}$

**Table 8.1**

Constant Acceleration Equations for Linear and Rotational Motion

Linear Motion	Rotational Motion
$v = v_0 + at$	$\omega = \omega_0 + \alpha t$
$d = v_0 t + \frac{1}{2} at^2$	$\theta = \omega_0 t + \frac{1}{2} \alpha t^2$



**Figure 8.4** The rider near the edge travels a greater distance in 1 revolution than the one near the center.

### How are linear and rotational velocity related?

How fast is the rider going when the merry-go-round in example box 8.2 is rotating with a velocity of 0.30 rev/s? The answer to this question depends on where the rider is sitting. He or she will move faster when seated near the edge of the merry-go-round than when seated near the center. The question involves a relationship between the linear speed of the rider and the rotational velocity of the merry-go-round.

In figure 8.4, the positions of the two riders are shown with dashed lines indicating the different radii. The rider seated at the greater distance from the center travels a larger distance in 1 revolution than the rider near the center, because the circumference of his circle is greater. The outside rider is therefore moving with a greater linear speed than the rider near the center.

The farther the rider is from the center, the farther he travels in 1 revolution, and the faster he is moving. The circumference of the circle on which the rider is traveling increases in proportion to the radius of the circle  $r$ , the distance of the rider from the center. If we express the rotational velocity in radians per second (rad/s), the relationship for the linear speed of the rider takes the form

$$v = r\omega$$

The linear speed  $v$  of a rider seated a distance  $r$  from the center of a merry-go-round is equal to  $r$  times the rotational velocity  $\omega$  of the merry-go-round. (For this simple relationship to be valid, however, the rotational velocity must be expressed in radians per second rather than revolutions or degrees per second.)

The rate at which the merry-go-round or other object turns will affect how fast a point on the rotating object will

move—in other words, its linear speed. Linear speed will depend on the distance from the axis of rotation. A child out at the edge of the merry-go-round will get a bigger thrill from the ride than one more timidly parked near the middle.

Rotational displacement, rotational velocity, and rotational acceleration are the quantities we need to fully describe the motion of a rotating object. They describe how far the object has rotated (rotational displacement), how fast it is rotating (rotational velocity), and the rate at which the rotation is changing (rotational acceleration). These definitions are analogous to similar quantities used to describe linear motion. They tell us how the object is rotating, but not why. Causes of rotation are considered next.

## 8.2 Torque and Balance

What causes the merry-go-round to rotate in the first place? To get it started, a child has to push it, which involves applying a force. The direction and point of application of force are important to the success of the effort. If the child pushes straight in toward the center, nothing happens. How do we apply a force to produce the best effect?

Unbalanced torques cause objects to rotate. What are *torques*, though, and how are they related to forces? A look at a simple scale or *balance* can help us get at the idea.

### When is a balance balanced?

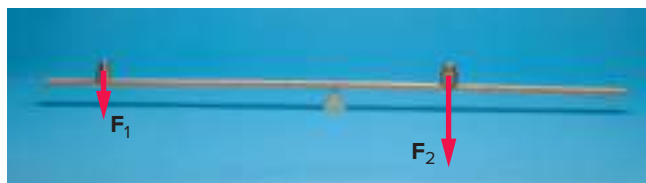
Consider a balance made of a thin but rigid beam supported by a **fulcrum**, or pivot point, as in figure 8.5. If the beam is balanced before we place weights on it, and if we put equal weights at equal distances from the fulcrum, we expect that the beam will still be balanced. By *balanced*, we mean that it will *not* tend to rotate about the fulcrum.

Suppose we wish to balance unequal weights on the beam. To balance a weight twice as large as a smaller weight, would we place the two weights at equal distances from the fulcrum? Intuition suggests that the smaller weight needs to be placed farther from the fulcrum than the larger weight for the system to be balanced, but it may not tell you how much



**Figure 8.5** A simple balance with equal weights placed at equal distances from the fulcrum.

James Ballard/McGraw-Hill Education



**Figure 8.6** A simple balance with unequal weights placed at different distances from the fulcrum. What determines whether the system will be balanced?

James Ballard/McGraw-Hill Education

farther (fig. 8.6). Trial and error with a simple balance will show that the smaller weight must be placed twice as far from the fulcrum as the larger (twice as large) weight.

Try it yourself using a ruler for the beam and a pencil for the fulcrum. Coins can be used as the weights. Experiments will show that both the weight and the distance from the fulcrum are important. The farther a weight sits from the fulcrum, the more effective it will be in balancing larger weights on the other side of the fulcrum. *Weight times distance from the fulcrum* determines the effect. If this product is the same for weights placed on either side of the fulcrum, the balance will not rotate.

### What is a torque?

This product of the force and the distance from the fulcrum—which describes the tendency of a weight to produce a rotation—is called the **torque**. More generally, it is described as the following.

The torque,  $\tau$ , about a given axis or fulcrum is equal to the product of the applied force and the lever arm,  $l$ :

$$\tau = Fl$$

The **lever arm** is the perpendicular distance from the axis of rotation to the line of action of the applied force.

The symbol  $\tau$  is the Greek letter tau and is commonly used for torque.

The length  $l$  is the distance from the fulcrum to the point of application of the force and must be measured in a direction perpendicular to the line of action of the force. This distance is called the *lever arm* or *moment arm* of the force in question. The strength of the torque depends directly on both the size of the force and the length of its lever arm. If the torques produced by weights on either side of the fulcrum of our balance are equal in magnitude, the scale is balanced. It will not rotate.

Most of us have tried to turn a nut with a wrench at some time. We exert the force at the end of the wrench, in a direction perpendicular to the handle (fig. 8.7). The handle is the lever, and its length determines the lever arm. A longer

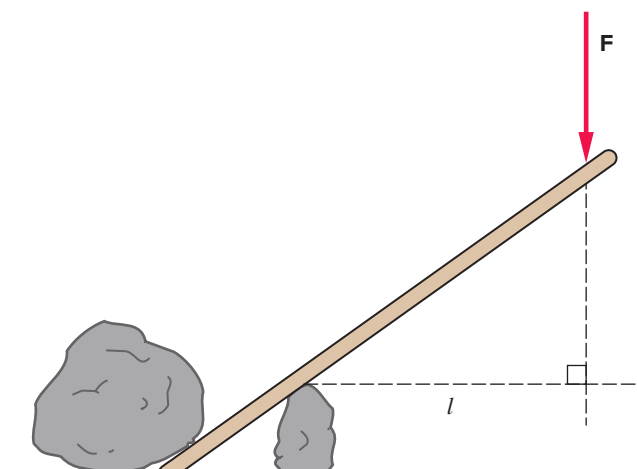


**Figure 8.7** A wrench with a long handle is more effective than one with a short handle because of the longer lever arm for the longer wrench.

James Ballard/McGraw-Hill Education

handle is more effective than a shorter one, because the resulting torque is greater.

As the term suggests, *lever arm* comes from our use of levers to move objects. Moving a large rock with a crowbar, for example, involves leverage. The applied force is most effective if it is applied at the end of the bar *and* perpendicular to the bar. The lever arm  $l$  is just the distance from the fulcrum to the end of the bar. If the force is applied in some other direction, as in figure 8.8, the lever arm is shorter than it would be if the force were applied perpendicular to the



**Figure 8.8** When the applied force is not perpendicular to the crowbar, the lever arm is found by drawing a perpendicular line from the fulcrum to the line of action of the force.

bar. The lever arm is found by drawing the perpendicular line from the fulcrum to the line of action of the force, as indicated in figure 8.8.

### How do torques add?

The direction of rotation associated with a torque is also important. Some torques tend to produce clockwise rotations and others counterclockwise rotations about a particular axis. For example, the torque due to the heavier weight on the right side of the fulcrum in figure 8.6 will produce a clockwise rotation about the fulcrum if it acts by itself. This is opposed by the equal-magnitude torque of the weight on the left side of the fulcrum, which would produce a counterclockwise rotation. The two torques cancel each other when the system is balanced.

Because torques can have opposing effects, we assign opposite signs to torques that produce rotations in opposite directions. If, for example, we chose to call torques that produce a counterclockwise rotation positive, torques producing clockwise rotations would be negative. (This is the conventional choice—it is unimportant which direction is chosen as positive as long as you are consistent in a given situation.) Identifying the sign of the torque indicates whether it will add to or subtract from other torques.

In the case of the simple balance, the net torque will be zero when the beam is balanced, because the two torques are equal but have opposite signs. The condition for balance, or equilibrium, is that the net torque acting on the system be zero. Either no torques act or the sum of the positive torques equals the sum of the negative torques, canceling one another by adding up to zero.

In example box 8.3, we find the distance that a 3-N weight must be placed from a fulcrum to balance a 5-N weight producing a net torque of zero. (Because  $W = mg$ , a 5-N weight has a mass of approximately 0.5 kg, or 500 g.) The units of torque are those of force times distance, Newton-meters (N·m) in the metric system.\*

### What is the center of gravity of an object?

Often, the weight of an object is itself an important factor in whether the object will rotate. How far, for example, could the child in figure 8.9 walk out on the plank without the plank's tipping? The weight of the plank is important in this case, and the concept of *center of gravity* is useful.

The **center of gravity** is the point about which the weight of the object itself exerts no net torque. If we suspended the object from its center of gravity, there would be no net torque at the suspension or support point. The object would be balanced. You can locate the center of gravity of a rodlike

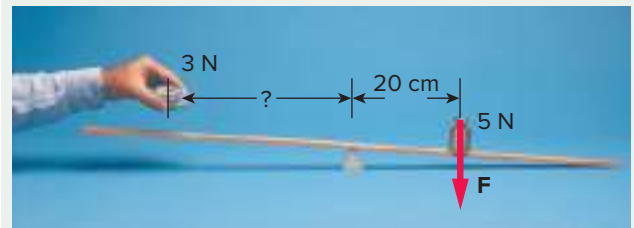
\*Although the product of a Newton-meter (N·m) equals a Joule (J) when we are using it as an energy unit, when a N·m is used as a torque unit, we state it as N·m, not Joules.

## Example Box 8.3

### Sample Exercise: Balancing a System

Suppose we have a 3-N weight that we want to balance against a 5-N weight on a beam, which is balanced when no masses are in place. The 5-N weight is placed 20 cm to the right of the fulcrum.

- What is the torque produced by the 5-N weight?
- How far would we have to place the 3-N weight from the fulcrum to balance the system?

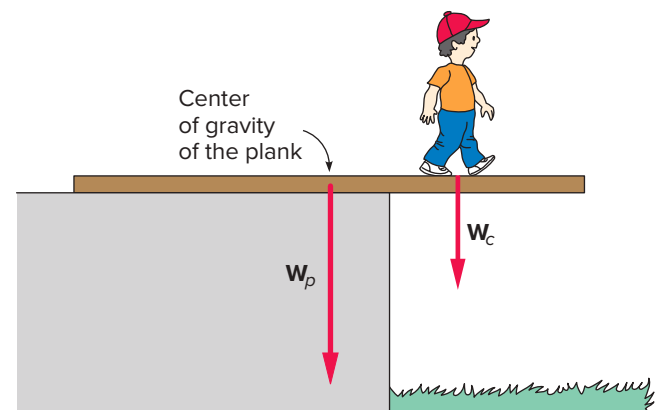


Where should the 3-N weight be placed on the beam to balance the system?  
*James Ballard/McGraw-Hill Education*

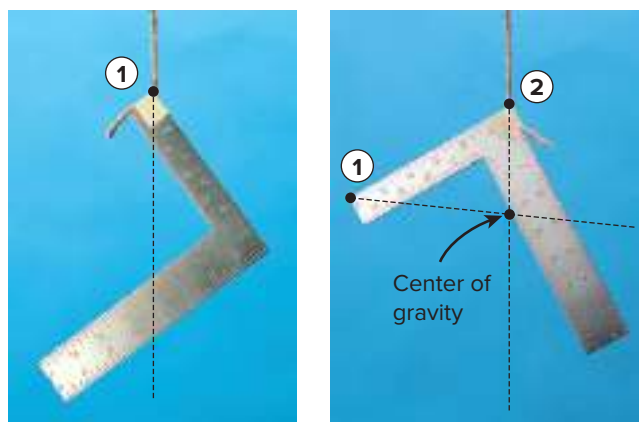
$$\begin{aligned} \text{a. } F &= 5 \text{ N} & \tau &= -Fl \\ l &= 20 \text{ cm} = 0.2 \text{ m} & &= -(5 \text{ N})(0.2 \text{ m}) \\ \tau &= ? & &= -1 \text{ N}\cdot\text{m} \end{aligned}$$

The minus sign indicates that this torque would produce a clockwise rotation.

$$\begin{aligned} \text{b. } F &= 3 \text{ N} & \tau &= Fl \\ l &= ? & l &= \frac{\tau}{F} \\ & & &= \frac{+1 \text{ N}\cdot\text{m}}{3 \text{ N}} \\ & & &= \mathbf{0.33 \text{ m (33 cm)}} \end{aligned}$$



**Figure 8.9** How far can the child walk without tipping the plank? The entire weight of the plank,  $W_p$ , can be treated as though it is located at the center of gravity.



**Figure 8.10** Locating the center of gravity of a planar object. The center of gravity does not necessarily lie within the object.  
James Ballard/McGraw-Hill Education

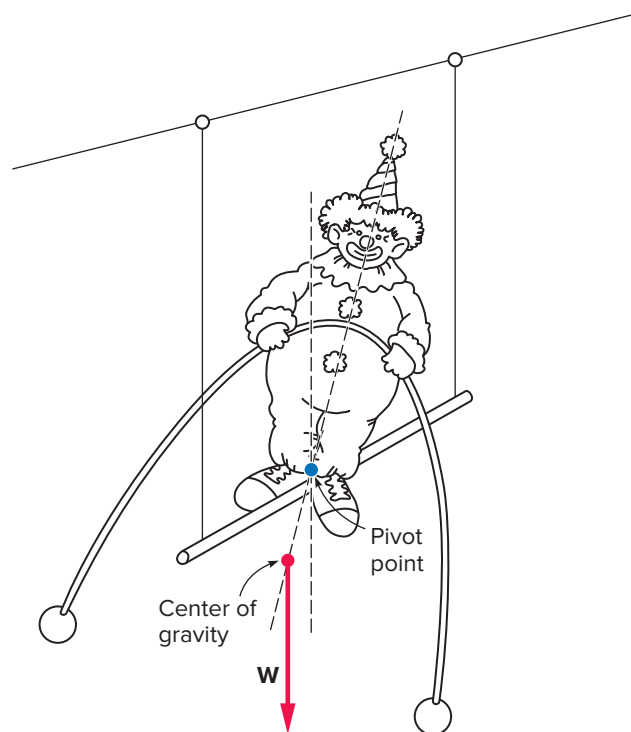
object by finding the point where it balances on your finger or other suitable fulcrum. For a more complex two-dimensional (planar) object, you can locate the center of gravity by suspending the object from two different points, drawing a line straight down from the point of suspension in each case, and locating the point of intersection of the two lines, as figure 8.10 illustrates.

In the case of the plank (fig. 8.9), the center of gravity is at the geometric center of the plank, provided that the plank is uniform in density and cut. The pivot point will be the edge of the supporting platform, the point to consider when computing torques. The plank will not tip as long as the counterclockwise torque produced by the weight of the plank about the pivot point is larger than the clockwise torque produced by the weight of the child. The weight of the plank is treated as though it is concentrated at the center of gravity of the plank.

The plank will verge on tipping when the torque of the child about the edge equals the torque of the plank in magnitude. This determines how far the child can walk on the plank before it tips. As long as the torque of the plank about the edge of the platform is larger than the torque of the child, the child is safe. The platform keeps the plank from rotating counterclockwise.

The location of the center of gravity is important in any effort at balancing. If the center of gravity lies below the pivot point, as in the balancing toy in figure 8.11, the toy will automatically regain its balance when disturbed. The center of gravity returns to the position directly below the pivot point, where the weight of the toy produces no torque. In this position, the lever arm for the weight of the clown and bar is zero.

Similarly, the location of your center of gravity is important in performing various maneuvers, athletic or otherwise. Try, for example, touching your toes with your back and heels against a wall. Why is this apparently simple trick impossible for most people to do? Where is your center of



**Figure 8.11** The clown automatically returns to an upright position, because the center of gravity is below the pivot point.

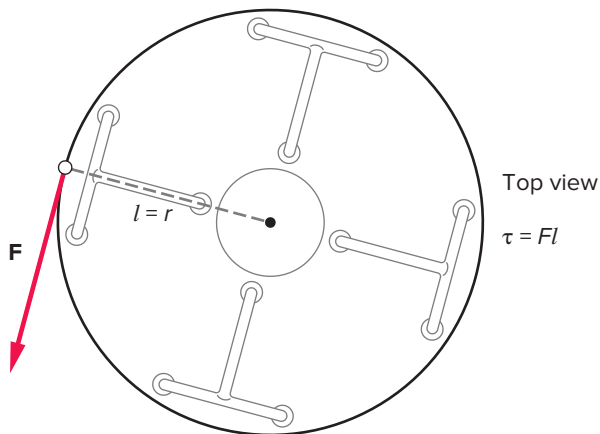
gravity relative to the pivot point determined by your feet? Center of gravity and torque are at work here.

Torques determine whether or not something will rotate. A torque is found by multiplying a force by its lever arm (the perpendicular distance from the axis of rotation to the line of action of the force). If the torque tending to produce a clockwise rotation equals the torque tending to produce a counterclockwise rotation, there is no rotation. If one of these torques is larger than the other, the torque will be unbalanced and the system will rotate.

### 8.3 Rotational Inertia and Newton's Second Law

When a child starts a merry-go-round rotating by running beside it and applying a force, the force exerted produces a torque about the axle. From our discussion in section 8.2, we know that the net torque acting on an object determines whether or not it will begin to rotate. Can we predict the rate of rotation by knowing the torque?

In linear motion, net force and mass determine the acceleration of an object, according to Newton's second law of motion ( $\mathbf{a} = \mathbf{F}/m$ ). How do we adapt Newton's second law to cases of rotational motion? In this case, *torque* determines the rotational acceleration. A new quantity, the rotational inertia, takes the place of mass.



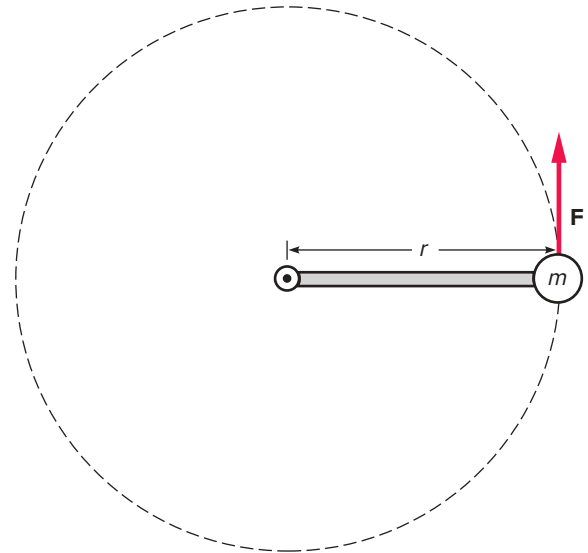
**Figure 8.12** The child exerts a force at the rim of the merry-go-round that produces a torque about the axle.  
(photo): Stockbyte/Getty Images

### What is rotational inertia?

Let's return to the merry-go-round. The propulsion system (one energetic child or tired parent) applies a force at the edge of the merry-go-round. The torque about the axle is found by multiplying this force by the lever arm—in this case, the radius of the merry-go-round (fig 8.12). If the frictional torque at the axle is small enough to be ignored, the torque produced by the child is the only one acting on the system. This torque produces the rotational acceleration of the merry-go-round.

How would we find this rotational acceleration? To find the linear acceleration produced by a force acting on an object, we use Newton's second law,  $\mathbf{F}_{\text{net}} = m\mathbf{a}$ . By analogy, we can develop a similar expression for rotational motion, where the torque  $\tau$  replaces the force and the rotational acceleration  $\alpha$  replaces the linear acceleration. But what quantity should we use in place of the *mass* of the merry-go-round?

In linear motion, mass represents the inertia, or resistance to a change in motion. For rotational motion, a new concept is needed, **rotational inertia**, also referred to as the **moment of inertia**. The rotational inertia is the resistance of an



**Figure 8.13** A single, concentrated mass at the end of a very light rod is set into rotation by the applied force  $\mathbf{F}$ . Use Newton's second law to find the acceleration.

object to change in its rotational motion. Rotational inertia is related to the mass of the object but also depends on how that mass is distributed about the axis of rotation.

To get a feeling for a concept, physicists often use the trick of considering the simplest possible situation. For rotational motion, the simplest case is a single, concentrated mass at the end of a very light rod, as in figure 8.13. If a force is applied to this mass in a direction perpendicular to the rod, the rod and mass will begin to rotate about the fixed axis at the other end of the rod.

For the rod and mass to undergo a rotational acceleration, the mass itself must have a linear acceleration. Like riders on a merry-go-round, however, the farther the mass is from the axis, the faster it moves for a given rotational velocity ( $v = r\omega$ ). To produce the same rotational acceleration, a mass at the end of the rod must receive a larger linear acceleration than one nearer the axis. It is harder to get the system rotating when the mass is at the end of the rod than when it is nearer to the axis.

Applying Newton's second law to this situation, we find that the resistance to a change in rotational motion depends on the *square* of the distance of this mass from the axis of rotation. Because the resistance to change also depends on the size of the mass, the rotational inertia of a concentrated mass is

$$\begin{aligned} \text{rotational inertia} &= \text{mass} \times \text{square of distance} \\ &\quad \text{from axis} \\ I &= mr^2 \end{aligned}$$

where  $I$  is the symbol commonly used for rotational inertia, and  $r$  is the distance of the mass  $m$  from the axis of rotation. The total rotational inertia of an object like the merry-go-round can be found by adding the contributions of different parts of the object lying at different distances from the axis.

## Newton's second law modified for rotational motion

By analogy to Newton's second law,  $\mathbf{F}_{\text{net}} = m\mathbf{a}$ , we can state the second law for rotational motion as follows:

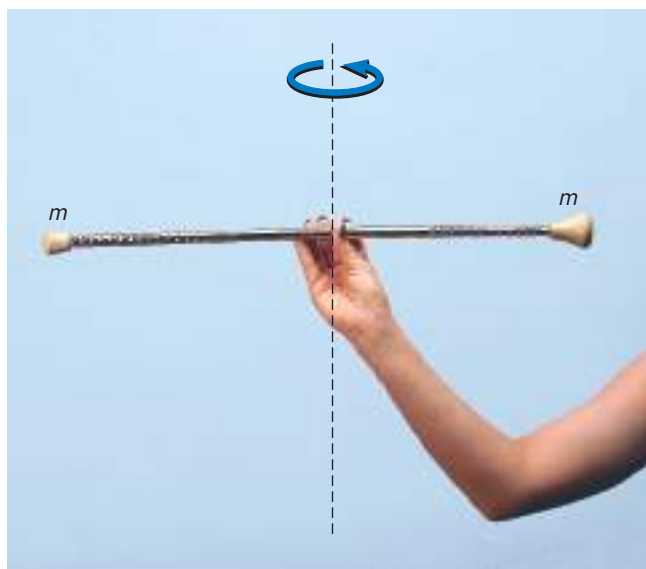
The net torque acting on an object about a given axis is equal to the rotational inertia of the object about that axis times the rotational acceleration of the object, or

$$\tau_{\text{net}} = I\alpha$$

To put it differently, the rotational acceleration produced is equal to the torque divided by the rotational inertia,  $\alpha = \tau_{\text{net}}/I$ . The larger the torque, the larger the rotational acceleration, *but* the larger the rotational inertia, the smaller the rotational acceleration. Rotational inertia dictates how hard it is to change the rotational velocity of the object.

To get a feel for these ideas, consider a simple object such as a twirler's baton. A baton consists of two masses at the end of a rod (fig. 8.14). If the rod itself is light, most of the baton's rotational inertia comes from the masses at each end. If you hold the baton at the center, a torque can be applied with your hand, producing a rotational acceleration and starting the baton to rotate.

Suppose we can move these masses along the rod. If we move the masses toward the center of the rod, so that the distance from the center is half the original distance, what happens to the rotational inertia? The rotational inertia decreases to one-fourth of its initial value, ignoring the contribution of the rod. Rotational inertia depends on the *square*



**Figure 8.14** The rotational inertia of a baton is determined largely by the masses at the ends.  
James Ballard/McGraw-Hill Education

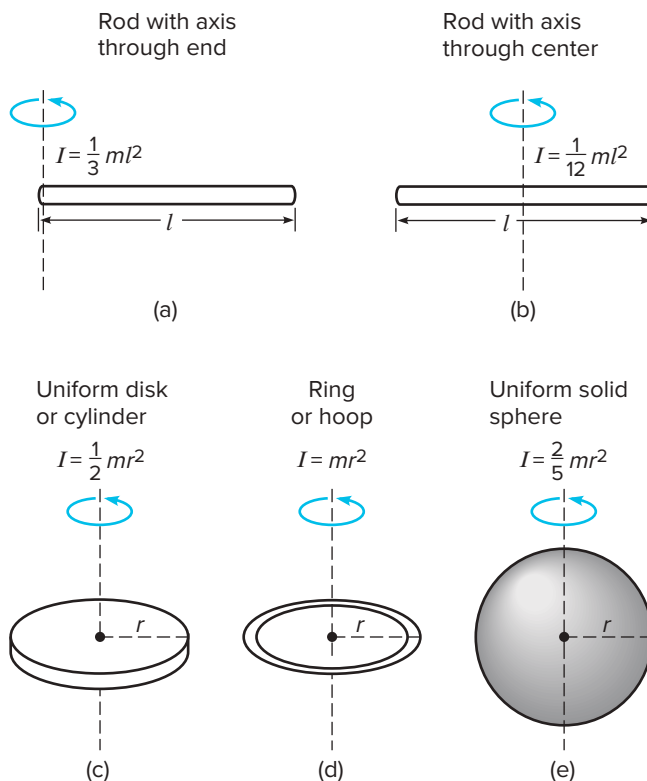
of the distance of the mass from the axis. Doubling the distance quadruples the rotational inertia. Halving the distance divides the rotational inertia by four.

The baton will be four times as hard to get to rotate when the masses are at the ends as when they are halfway from the ends. In other words, the torque needed to produce a rotational acceleration will be four times as large when the masses are at the ends as when they are at the intermediate positions. If you had a rod with adjustable masses, you could feel the difference in the amount of torque needed to start it rotating. Try a pencil with lumps of clay for the masses as a substitute.

## Finding the rotational inertia of the merry-go-round

Finding the rotational inertia of an object like a merry-go-round is more difficult than just multiplying the mass by the square of the radius. Not all of the mass of the merry-go-round is at the outer edge—some of it is closer to the axis and will make a smaller contribution to the rotational inertia. Imagine breaking down the merry-go-round into several pieces, finding the rotational inertia of each piece, and adding together the rotational inertias for all the pieces to get the total.

Results of this process for a few simple shapes are shown in figure 8.15. The equations illustrate the ideas we have



**Figure 8.15** Expressions for the rotational inertia of several objects, each with a uniform distribution of mass over its volume. The letter  $m$  is used to represent the total mass of the object.

## Example Box 8.4

### Sample Exercise: Turning a Merry-Go-Round and a Rider

A simple merry-go-round has a rotational inertia of  $800 \text{ kg}\cdot\text{m}^2$  and a radius of 2 m. A child with a mass of 40 kg sits near the edge of the merry-go-round.

- What is the total rotational inertia of the merry-go-round and the child about the axis of the merry-go-round?
- What torque is required to give the merry-go-round and child a rotational acceleration of  $0.05 \text{ rad/s}^2$ ?

$$\begin{aligned} \text{a. } I_{\text{merry-go-round}} &= 800 \text{ kg}\cdot\text{m}^2 & I_{\text{child}} &= mr^2 \\ m_{\text{child}} &= 40 \text{ kg} & &= (40 \text{ kg})(2 \text{ m})^2 \\ r &= 2 \text{ m} & &= 160 \text{ kg}\cdot\text{m}^2 \end{aligned}$$

The total rotational inertia is

$$\begin{aligned} I_{\text{total}} &= I_{\text{merry-go-round}} + I_{\text{child}} \\ &= 800 \text{ kg}\cdot\text{m}^2 + 160 \text{ kg}\cdot\text{m}^2 \\ &= \mathbf{960 \text{ kg}\cdot\text{m}^2} \end{aligned}$$

$$\begin{aligned} \text{b. } \alpha &= 0.05 \text{ rad/s}^2 & \tau_{\text{net}} &= I\alpha \\ \tau_{\text{net}} &= ? & &= (960 \text{ kg}\cdot\text{m}^2)(0.05 \text{ rad/s}^2) \\ & & &= \mathbf{48 \text{ N}\cdot\text{m}} \end{aligned}$$

discussed. For example, a solid disk has a smaller rotational inertia than a ring of the same mass and radius, because the mass of the disk is, on average, closer to the axis. The location of the axis is also important. A rod has a larger rotational inertia about an axis through one end than about an axis through the middle. When the axis of rotation is at the end of the rod, there is more mass at greater distances from the axis.

Depending on how it is constructed, the merry-go-round might be like a solid disk. A child sitting on the merry-go-round will also affect the rotational inertia. If several children all sit near the edge of the merry-go-round, their rotational inertia makes it more difficult to get the merry-go-round moving. If the children cluster near the center, they provide less additional rotational inertia. If you are feeling tired, have the children sit near the middle. You will save some effort.

Example box 8.4 attaches some numbers to these quantities. A child sitting on a merry-go-round is being accelerated by a push at a rate of  $0.05 \text{ rad/s}^2$ .<sup>\*</sup> A torque of  $48 \text{ N}\cdot\text{m}$  is needed to produce this rotational acceleration. A force of  $24 \text{ N}$  applied at the edge would have a lever arm of 2 m and produce the necessary torque of  $48 \text{ N}\cdot\text{m}$ , a reasonable force for a child to generate if the child is not too small.

<sup>\*</sup>To use Newton's second law for rotational motion, the rotational acceleration must be stated in radians per second squared. If the rotational acceleration is provided in  $\text{rev/s}^2$  or some other angular unit, we convert it to  $\text{rad/s}^2$  before proceeding.

Rotational inertia is the resistance to change in rotational motion. It depends on both the mass of the object and the distribution of that mass about the axis of rotation. The rotational form of Newton's second law,  $\tau_{\text{net}} = I\alpha$ , shows the quantitative relationship between torque, rotational inertia, and rotational acceleration. Torque takes the place of force, rotational inertia replaces mass, and rotational acceleration replaces linear acceleration.

## 8.4 Conservation of Angular Momentum

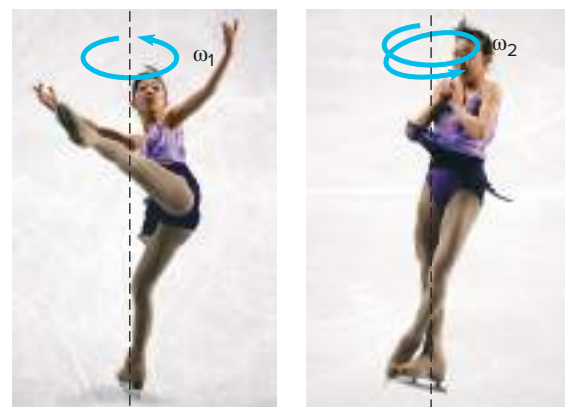
Have you ever watched an ice skater go into a spin? She starts the spin with her arms and one leg extended, then brings them in toward her body. As she brings her arms in, the rate of the spin increases; as she extends her arms again, her rotational velocity decreases (fig. 8.16).

The concept of angular, or rotational, momentum is useful in situations like this. The principle of conservation of angular momentum explains a variety of phenomena like the ice skater and includes tumbling divers or gymnasts, as well as the motion of the planets around the sun. How can we use the analogy between linear and rotational motion to understand these ideas?

### What is angular momentum?

If you were asked to invent the idea of angular (rotational) momentum, how would you go about it? As discussed in chapter 7, linear momentum is the mass (the inertia) times the linear velocity of an object ( $\mathbf{p} = m\mathbf{v}$ ). An increase in either the mass or the velocity increases the momentum. Because it is a measure of both how much is moving and how fast it is moving, Newton called momentum the *quantity of motion*.

What is momentum's rotational equivalent? In comparing rotational and linear motion, rotational inertia plays the role of mass, while rotational velocity replaces linear



**Figure 8.16** The rotational velocity of the skater increases as she pulls her arms and leg in toward her body.

(both): Jeff Haynes/AFP/Getty Images



velocity. By analogy, we can define **angular momentum** as follows:

Angular momentum is the product of the rotational inertia and the rotational velocity, or

$$L = I\omega$$

where  $L$  is the symbol used for angular momentum.

The term *angular momentum* is more common than *rotational momentum*, but either can be used.

Like linear momentum, angular momentum is the product of two quantities: an inertia and a velocity. A bowling ball spinning slowly might have the same angular momentum as a baseball spinning much more rapidly because of the larger rotational inertia  $I$  of the bowling ball. With its enormous rotational inertia, the Earth has a huge angular momentum associated with its daily turn about its axis, even though the rotational velocity is small.

### When is angular momentum conserved?

We have used the analogy between linear and rotational motion to introduce angular momentum. Can we also use it to state the principle of conservation of angular momentum? In chapter 7, we found that linear momentum is conserved when there is no net external force acting on a system. When would angular momentum be conserved?

Because torque takes the role of force for rotational motion, we can state the principle of **conservation of angular momentum** thus:

If the net torque acting on a system is zero, the total angular momentum of the system is conserved.

Torque replaces force, and angular momentum replaces ordinary or linear momentum. Table 8.2 lists some important parallels between linear and rotational motion.

**Table 8.2**

Corresponding Concepts of Linear and Rotational Motion

Concept	Linear Motion	Rotational Motion
Inertia	$m$	$I$
Newton's second law	$\mathbf{F}_{\text{net}} = m\mathbf{a}$	$\boldsymbol{\tau}_{\text{net}} = I\boldsymbol{\alpha}$
Momentum	$\mathbf{p} = m\mathbf{v}$	$L = I\omega$
Conservation of momentum	If $\mathbf{F}_{\text{net}} = 0$ , $\mathbf{p} = \text{constant}$	If $\boldsymbol{\tau}_{\text{net}} = 0$ , $L = \text{constant}$
Kinetic energy	$KE = \frac{1}{2}mv^2$	$KE = \frac{1}{2}I\omega^2$

### Changes in the ice skater's rate of spin

Conservation of angular momentum is the key to understanding what happens when the spinning ice skater increases her rotational velocity by pulling in her arms. The external torque acting on the skater about her axis of rotation is very small, so the condition for conservation of angular momentum exists. Why does her rotational velocity increase?

When the skater's arms and one leg are extended, they contribute a relatively large portion to her total rotational inertia—their average distance from her axis of rotation is much larger than for other portions of her body. Rotational inertia depends on the square of the distance of various portions of her mass from the axis ( $I = mr^2$ ). The effect of this distance is substantial, even though her arms and one leg are only a small part of the total mass of the skater. When the skater pulls her arms and leg in toward her body, their contribution to her rotational inertia decreases, and therefore her total rotational inertia decreases.

Conservation of angular momentum requires that her angular momentum remain constant. Because angular momentum is the product of the rotational inertia and rotational velocity,  $L = I\omega$ , if  $I$  decreases,  $\omega$  must increase for angular momentum to stay constant. She can slow her rate of spin by extending her arms and one leg again, which she does at the end of the spin. This increases her rotational inertia and decreases her rotational velocity: Angular momentum is conserved. These ideas are illustrated in example box 8.5.

This phenomenon can be explored using a rotating platform or stool with good bearings to keep the frictional torques small (fig. 8.17). In these demonstrations, students can hold masses in their hands, which increase the changes in rotational inertia that happen as the arms are drawn in toward the body. A striking increase in rotational velocity can be achieved!

### Example Box 8.5

#### Sample Exercise: Some Physics of Figure Skating

An ice skater has a rotational inertia of  $1.2 \text{ kg}\cdot\text{m}^2$  when her arms are extended and a rotational inertia of  $0.5 \text{ kg}\cdot\text{m}^2$  when her arms are pulled in close to her body. If she goes into a spin with her arms extended and has an initial rotational velocity of  $1 \text{ rev/s}$ , what is her rotational velocity when she pulls her arms in close to her body?

$I_1 = 1.2 \text{ kg}\cdot\text{m}^2$ $I_2 = 0.5 \text{ kg}\cdot\text{m}^2$ $\omega_1 = 1 \text{ rev/s}$ $\omega_2 = ?$	Because angular momentum is conserved $L_{\text{final}} = L_{\text{initial}}$ $I_2\omega_2 = I_1\omega_1$
--	---

Dividing both sides by  $I_2$ ,

$$\begin{aligned} \omega_2 &= (I_1/I_2)\omega_1 \\ &= (1.2 \text{ kg}\cdot\text{m}^2/0.5 \text{ kg}\cdot\text{m}^2)(1 \text{ rev/s}) \\ &= (2.4)(1 \text{ rev/s}) \\ &= \mathbf{2.4 \text{ rev/s}} \end{aligned}$$



**Figure 8.17** A student holding masses in each hand while sitting on a rotating stool can achieve a large increase in rotational velocity by bringing his arms in toward his body.

*James Ballard/McGraw-Hill Education*

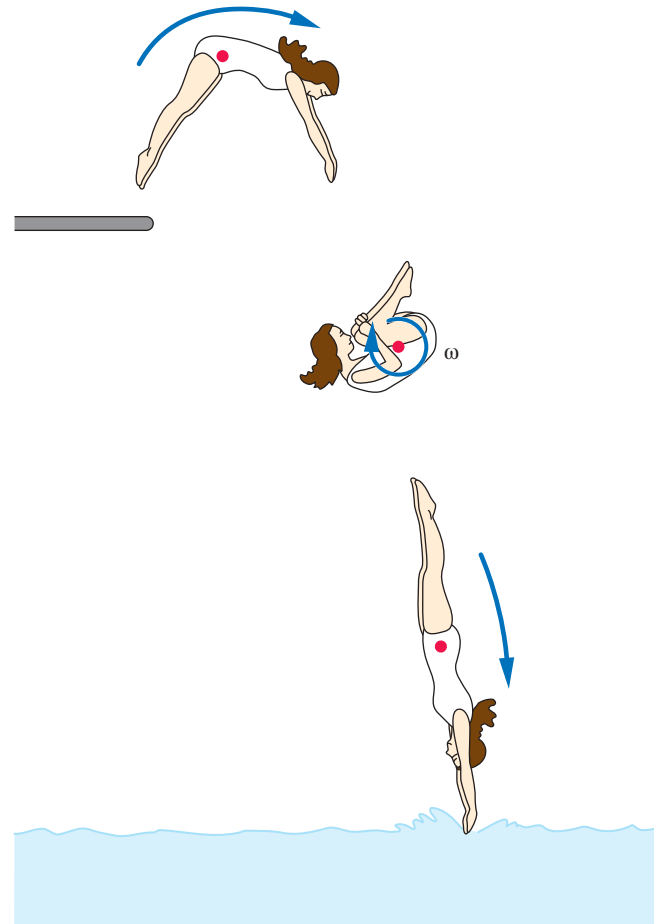
A similar effect is at work when a diver pulls into a tuck position to produce a spin. In this case, the diver starts with her body extended and a slow rate of rotation about an axis through her body's center of gravity (fig. 8.18). As she goes into a tuck, the rotational inertia about this axis is reduced, and rotational velocity increases. As her dive nears completion, she comes out of the tuck, increasing the rotational inertia and decreasing the rotational velocity. (The torque about the center of gravity due to the gravitational force acting on the diver is zero.)

There are many examples of varying the rotational velocity by changing the rotational inertia. It is much easier to produce a change in the rotational inertia of a body than to change the mass of the body. We simply change the distance of various portions of the mass from the axis of rotation. Conservation of angular momentum provides a quick explanation for these phenomena.

### Kepler's second law

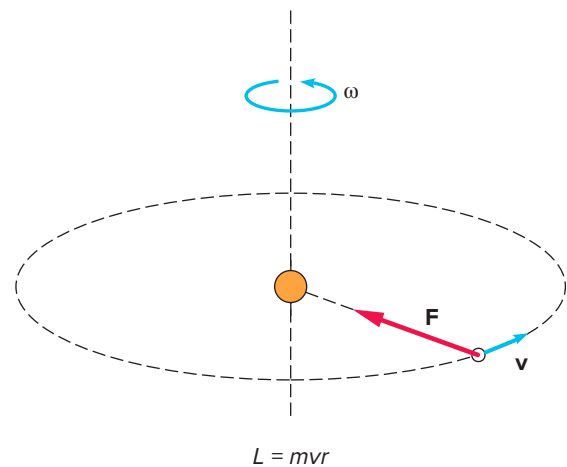
Conservation of angular momentum also plays a role in the orbit of a planet about the sun; in fact, it can be used to explain Kepler's second law of planetary motion (see section 5.3). Kepler's second law says that the radius line from the sun to the planet sweeps out equal areas in equal times. The planet moves faster in its elliptical orbit when it is nearer to the sun than when it is farther from the sun.

The gravitational force acting on the planet produces no torque about the sun, because its line of action passes



**Figure 8.18** The diver increases her rotational velocity by pulling into a tuck position, thus reducing her rotational inertia about her center of gravity.

directly through the sun (fig. 8.19). The lever arm for this force is zero, and the resulting torque must also be zero. Angular momentum, therefore, is conserved.



**Figure 8.19** The gravitational force acting on the planet produces no torque about an axis through the sun, because the lever arm is zero for this force.

When the planet moves nearer to the sun, its rotational inertia  $I$  about the sun decreases. To conserve angular momentum, the rotational velocity of the planet about the sun (and thus its linear velocity\*) must increase to keep the product  $L = I\omega$  constant. This requirement results in equal areas being swept out by the radius line in equal times. The velocity of the planet must be larger when the radius gets smaller to keep the area being swept out the same.

You can observe a related effect in a simple experiment with a ball on a string. If you let the string wrap around your finger as it rotates, which produces a smaller radius of rotation, the ball will increase its rotational velocity about your finger. The rotational velocity  $\omega$  increases as the rotational inertia  $I$  decreases because of the decreased radius. Angular momentum is conserved. Try it!

Everyday phenomenon box 8.1 provides an example in which angular momentum is conserved at some points in the motion of a yo-yo. At other points, the angular momentum changes under the influence of torques.

By analogy to linear momentum, angular momentum is the product of the rotational inertia and the rotational velocity. Angular momentum is conserved when the net external torque acting on a system is zero. Decreases in rotational inertia lead to increases in rotational velocity, as demonstrated by the spinning ice skater. A spinning diver, a ball rotating at the end of a string, and a planet orbiting the sun are other examples of this effect.

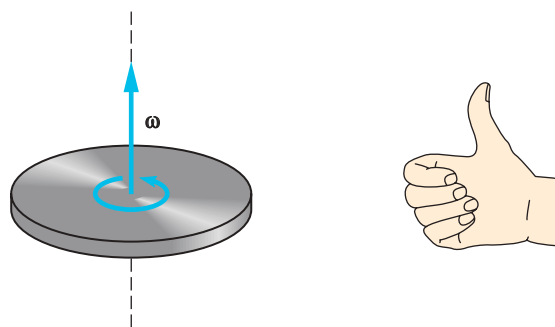
## 8.5 Riding a Bicycle and Other Amazing Feats

Have you ever wondered why a bicycle remains upright when it is moving but promptly falls over when not moving? Angular momentum is involved, but some additional wrinkles are needed in the explanation. The direction of angular momentum is an important consideration. How can angular momentum have direction, and how is this direction involved in explaining the behavior of a bicycle, a spinning top, or other phenomena?

### Is angular momentum a vector?

Linear momentum is a vector, and the direction of the momentum  $\mathbf{p}$  is the same as that for the velocity  $\mathbf{v}$  of the object. Because angular momentum is associated with a rotational velocity, the question comes down to whether rotational

\*For a compact mass rotating about some axis, the definition of angular momentum reduces to  $L = mvr$ , where  $mv$  is the linear momentum and  $r$  is the perpendicular distance from the axis of rotation to the line along which the object is moving at that instant. If  $r$  decreases,  $v$  must increase to conserve angular momentum.



**Figure 8.20** The direction of the rotational-velocity vector for the counterclockwise rotation is defined to be upward along the axis of rotation, as indicated by the thumb on the right hand with the fingers curled in the direction of rotation.

velocities have direction. How would we define the direction of a rotational velocity?

If a merry-go-round (or just a disk) is rotating in a counterclockwise direction, as in figure 8.20, how might we indicate that direction with an arrow? The term *counterclockwise* indicates the direction of rotation as seen from a certain perspective, but it does not define a unique direction. To complete our description, we would also have to specify the axis of rotation and our perspective, or viewpoint. An object seen rotating counterclockwise when viewed from above is seen rotating clockwise when viewed from below. We could draw an axis of rotation and a curved arrow around it, as we often do, but it would be more desirable to specify direction with a simple straight arrow.

The usual solution to this problem is to define the direction of the rotational-velocity vector as being along the axis of rotation and in the upward direction for the counterclockwise rotation in figure 8.20. A rule for whether the vector should point up or down along the axis can be defined with the help of your right hand. If you hold your right hand with the fingers curling around the axis of rotation in the direction of the rotation, your thumb points in the direction of the rotational-velocity vector. This is referred to as the **right-hand rule**. If the merry-go-round were rotating clockwise (instead of counterclockwise), your thumb would point down, the direction of the rotational-velocity vector. Try it. Be careful to use your right hand (even if you are lucky enough to be left-handed).

The direction of the angular-momentum vector is the same as the rotational velocity, because  $\mathbf{L} = I\omega$ . Conservation of angular momentum requires that the *direction* of the angular-momentum vector remain constant, as well as its magnitude.

### Angular momentum and bicycles

Most of us have had some experience with riding a bicycle. The wheels of a bicycle acquire angular momentum when the bicycle is moving. Torque is applied to the rear wheel by the pedals and chain to produce a rotational acceleration. If the bicycle is moving in a straight line, the direction of the

## Everyday Phenomenon

## Box 8.1

## Achieving the State of Yo

**The Situation.** A physics professor noticed that one of his students often carried a yo-yo to class and was proficient at putting the yo-yo through its paces. The professor challenged the student to explain the behavior of the yo-yo using the principles of torque and angular momentum.

In particular, the professor asked the student to explain why the yo-yo sometimes comes back but sometimes can be made to “sleep,” or continue to rotate, at the end of the string. What are the differences in these two situations?



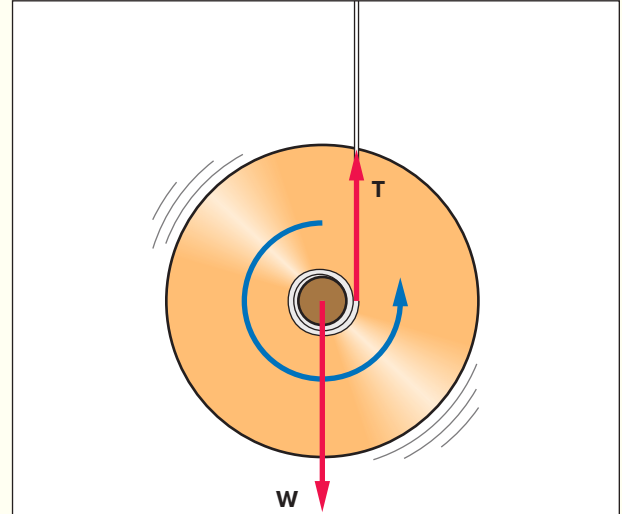
A yo-yo will come back to your hand, or with sufficient skill, you can make it “sleep” at the end of its string.

*Kelly Redinger/Design Pics*

**The Analysis.** The student carefully examined the yo-yo’s construction and how the string is attached. He noticed that the string is not tied tightly to the axle of the yo-yo but ends in a loose loop around the axle instead. When the yo-yo is at the end of its string, the string can slip on the axle. When wound around the axle, on the other hand, the string is less likely to slip.

Usually, the yo-yo is started with the string wound around the axle and looped around the middle finger. When the yo-yo is released from the hand, the string unwinds, and the yo-yo gains rotational velocity and angular momentum. The student reasoned that a torque must be at work, and he drew a force diagram for the yo-yo that looked like the one in the diagram. Two forces act on the yo-yo: its weight acting downward and the tension in the string acting upward.

Because the yo-yo is accelerated downward, the weight must be greater than the tension to produce a downward net force. The weight does not produce a torque about the center of gravity of the yo-yo, though, because its line of action passes through the center of gravity, and the lever arm is zero. The tension acts along a line that is off-center and produces a torque that will cause a counterclockwise rotation about the center of gravity, as in the drawing.



A cut-away diagram showing the forces acting on the yo-yo when it is falling. Its weight and the tension in the string are the only significant forces.

The torque due to the tension in the string produces a rotational acceleration, and the yo-yo gains rotational velocity and angular momentum as it falls. The yo-yo has a sizable angular momentum when it reaches the bottom of the string, and in the absence of external torques to change this angular momentum, it will be conserved. This is what happens when the yo-yo “sleeps” at the bottom of the string: The only torque acting is the frictional torque of the string slipping on the axle, and this will be small if the axle is smooth.

What happens, however, when the yo-yo returns to the student’s hand? The yo-yo artist (yo-yoist?) jerks lightly on the string at the instant that the yo-yo reaches the bottom of the string. This jerk provides a brief impulse and upward acceleration of the yo-yo. Because it is already spinning, the yo-yo continues spinning in the same direction, and the string rewinds itself around the axle of the yo-yo. The line of action of the tension in the string is now on the opposite side of the axle, though, and its torque causes the rotational velocity and angular momentum to decrease. The rotation should stop when the yo-yo slips back into the student’s hand.

When the yo-yo is rising, the net force acting on the yo-yo is still downward, and the linear velocity of the yo-yo decreases, along with its rotational velocity. The only time a net force acts upward is when the upward impulse is delivered by jerking on the string. The situation is similar to a ball bouncing on the floor—the net force is downward except during the very brief time of contact with the floor. Our ability to affect the nature and timing of the impulse through the string causes the yo-yo either to sleep or to return. This is what the “art of yo” is all about.



**Figure 8.21** The angular-momentum vector for each wheel is horizontal when the bicycle is upright.

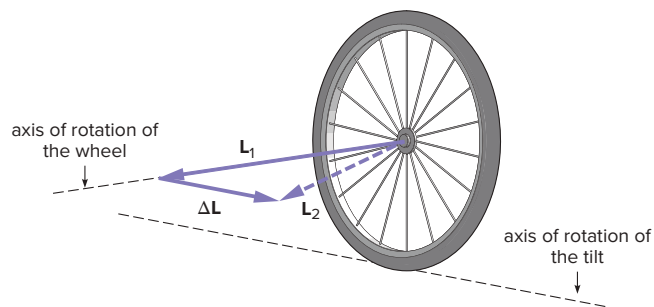
Bob Coyle/McGraw-Hill Education

angular-momentum vector is the same for both wheels and is horizontal (fig. 8.21).

To tip the bike over, the direction of the angular-momentum vector must change, and that requires a torque. This torque would normally come from the gravitational force acting on the rider and the bicycle through their center of gravity. When the bicycle is exactly upright, this force acts straight downward and passes through the axis of rotation for the falling bike. This axis of rotation is the line along which the tires contact the road. The torque about this axis will be zero, because the line of action of the force passes through the axis of rotation and the lever arm is zero. The direction and magnitude of the original angular momentum are conserved.

If the bike is not perfectly upright, a gravitational torque acts about the line of contact of the tires with the road. As the bike begins to fall, it acquires a rotational velocity and angular momentum about this axis. By the right-hand rule, the direction of that angular-momentum vector is along the axis and points forward or backward depending on the direction of tilt. If the bike tilts to the left as seen from behind, the change in angular momentum associated with this torque points straight back, as in figure 8.22.

If the bike is standing still, that is all there is to it—the gravitational torque causes the bike to fall. When the bike is moving, however, the change in angular momentum  $\Delta\mathbf{L}$  produced by the gravitational torque adds to the angular momentum already present ( $\mathbf{L}_1$ ) from the rotating tires. As shown in figure 8.22, this causes a change in the direction of



**Figure 8.22** The change in angular momentum ( $\Delta\mathbf{L}$ ) associated with a leftward tilt points straight back, parallel to the line of contact of the tires with the road. This change causes the angular-momentum vector (and the wheel) to turn to the left.

the total angular-momentum vector ( $\mathbf{L}_2$ ). This change in direction can be accommodated simply by turning the wheel of the bicycle rather than letting the bike fall. We compensate for the effects of the gravitational torque by turning the bicycle toward the direction of the impending fall. The larger the initial angular momentum, the smaller the turn required. The angular momentum of the wheels is a major factor in stabilizing the bicycle.

## Study Hint

Visualizing these angular momentum vectors and their changes can be an abstract and difficult task. The effect will seem much more real if you can directly experience it. If a bicycle wheel mounted on a handheld axle (such as that pictured in figure 8.23) is available, try the tilt effect yourself. Grasp the wheel with both hands by the handles on each side and have someone give it a good spin with the wheel in a vertical plane. Then, try tilting the wheel downward to the left to simulate a fall. The wheel will seem to have a mind of its own and will turn to the left, as suggested by figure 8.22.

This result may be surprising—yet all of us who have ridden bicycles take advantage of it routinely. When the bike is moving slowly, sharp turns of the wheel can keep it from falling while you shift your weight. Smaller adjustments suffice when the bike is moving more rapidly. By leaning into a curve, you use the gravitational torque to change the direction of angular momentum, helping to round the curve. Likewise, if you roll a coin along a tabletop, you will see it curve as it begins to fall. The path curves in the direction the coin is tilting.

You can also observe this effect of torque in changing the direction of an angular-momentum vector by holding a bicycle upright on its rear wheel and having a friend spin the front wheel. It is harder to change the direction of this wheel when it is spinning rapidly than when it is spinning slowly or not at all. You will also get the feeling that the wheel has a mind of its own. As you try to tilt the wheel, it will tend to turn in a direction perpendicular to the tilt.



**Figure 8.23** A student holds a spinning bicycle wheel while sitting on a stool that is free to rotate. What happens if the wheel is turned upside down?

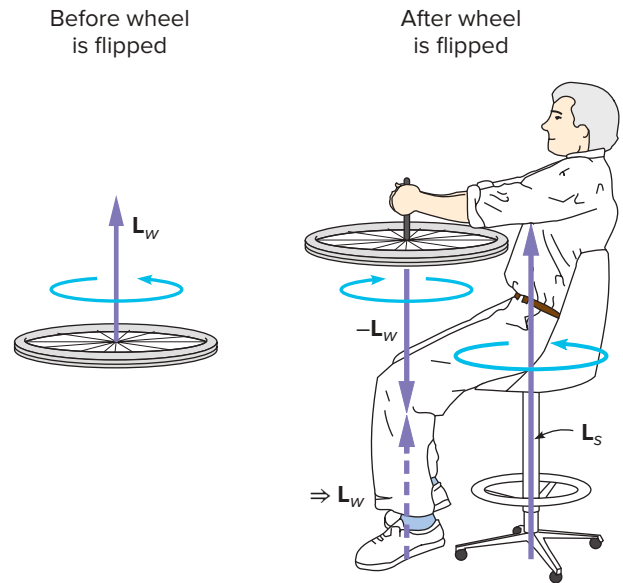
(both): James Ballard/McGraw-Hill Education

A bicycle tire mounted on a handheld axle is even more effective for sensing the effects of torques applied to the axle. This is a common demonstration apparatus, but usually the tire is filled with steel cable rather than air. The steel cable gives the wheel a larger rotational inertia and a larger angular momentum for a given rate of spin. If you hold the axle on either side while the wheel is spinning in a vertical plane and then try to tip the wheel, you get a sense of what happens when you are riding a bicycle. It also demonstrates how hard it is to change the direction of the angular momentum of a rapidly spinning wheel. Everyday phenomenon box 8.2 discusses how torques are involved in the gear system of a bicycle.

### Rotating stools and tops

The handheld bicycle wheel is good for other demonstrations that highlight angular momentum as a vector. If a student holds the wheel with its axle in the vertical direction while sitting on a rotating stool, conservation of angular momentum produces striking results. It is best to start the wheel spinning while holding the stool, so that the stool does not rotate initially. The student then turns the wheel over, as in figure 8.23, reversing the direction of the angular-momentum vector of the wheel.

Can you imagine what happens then? To conserve angular momentum, the original direction of the angular-momentum vector must be maintained. The only way this can happen is for the stool with the student volunteer to begin to rotate in the same direction that the wheel was rotating *initially*. The sum of the angular-momentum vector of the wheel about its axis of rotation and the angular-momentum vector of the student, stool, and wheel about the axis of rotation of the stool add to yield the original angular momentum (fig. 8.24). This will be true if the angular momentum gained by the student, stool, and wheel is exactly twice the original angular momentum of



**Figure 8.24** The angular momentum of the objects about the rotation axis of the stool,  $\mathbf{L}_s$ , adds to the angular momentum of the wheel about its own axis,  $-\mathbf{L}_w$ , to yield the direction and magnitude of the original angular momentum,  $\mathbf{L}_w$ .

the wheel. The student can stop the rotation of the stool by flipping the wheel axis back to its original direction.

The direction of angular momentum and its conservation are important in many other situations. The angular momentum of the helicopter's rotors, for example, is an extremely important factor in helicopter design. The motion of a top also shows fascinating effects. If you have a top, observe what happens to the direction of the angular-momentum vector as the top slows down. As the top begins to totter, the change in direction of the angular-momentum vector causes the rotation axis of the top to rotate (precess) about a vertical line. Does this remind you of what happens with a bicycle wheel?

Angular momentum and its direction are also central to atomic and nuclear physics. The particles that make up atoms have spins, and these spins imply angular momentum. The ways these angular-momentum vectors add are used to explain a variety of atomic phenomena. While the size scales differ enormously, it is useful to recognize the common ground that atoms and nuclei share with bicycle wheels and the solar system.

Like linear momentum, angular momentum is a vector. Its direction is the same as that of the rotational-velocity vector, which is along the axis of rotation, with the right-hand rule specifying which way it points along that axis. Conservation of angular momentum requires that both the magnitude and the direction of the angular-momentum vector be constant (if there are no external torques). Many interesting phenomena can be explained using these ideas, including the stability of a moving bicycle, the motion of a spinning top, and the behavior of atoms and galaxies.

## Everyday Phenomenon

## Box 8.2

## Bicycle Gears

**The Situation.** Most modern bicycles come equipped with the ability to change gears. When we are climbing a hill, we shift into a low gear, making pedaling easier. When we are on level ground or a downgrade, we shift into higher gears, allowing us to cover more ground per turn of the pedal crank.

How do these gears work? How does the torque exerted on the rear wheel change when we change gears? What is the advantage of having many different gears? Adding a rotational twist to the concept of simple machines can help in understanding how gears work. Similar ideas apply to an automobile transmission.



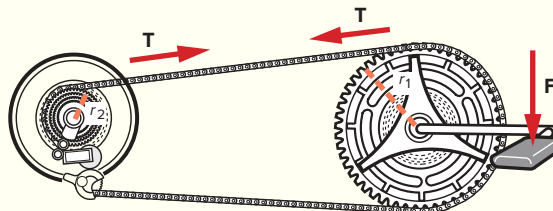
There are seven different sprockets on the rear-wheel gear assembly of a 21-speed bicycle. The two smaller sprockets on the pedal wheel lie behind the largest sprocket.

*Adam Gault/OJO Images/Getty Images*

**The Analysis.** The photograph above shows the pedal wheel and the rear-wheel gear assembly for a 21-speed bicycle. There are seven sprockets (toothed wheels) of different sizes on the rear-wheel hub. There are also three different sprockets on the pedal wheel, only one of which is fully visible in the photograph. A pulley and lever mechanism (called a derailleurs) allows us to move the chain from one sprocket to another. This is controlled by levers mounted on the handlebars that are linked to the derailleurs by cables.

When we pedal the bicycle, we apply a torque to the pedal sprocket by pushing on the pedals. If our feet push perpendicularly to the pedal shaft, then the lever arm is just the length of the shaft. That will be the case when the pedal is in the forward position where we get maximum torque, as shown in the drawing. This maximum-torque position alternates from the left foot to the right foot as the crank turns.

The torque exerted on the pedal chain ring causes the sprocket to accelerate rotationally, provided that this torque is larger than the opposing torque exerted by the tension in the chain pulling back on the sprocket. This tension, in turn, produces a torque on the rear wheel via the rear-wheel sprocket. The size of the torque transmitted to the rear wheel depends on



A force applied to the pedal produces a torque on the pedal wheel. This torque produces a tension in the chain that exerts a smaller torque on the rear-wheel sprocket due to its smaller radius.

which of the several sprockets is engaged with the chain. A larger sprocket radius yields a larger torque because of the greater lever arm. (The lever arm is equal to the radius of the sprocket engaged.) As with an automobile, the rear wheel pushes against the road surface via friction, and by Newton's third law, the frictional force pushes forward on the bicycle.

How are simple-machine ideas involved? Suppose the chain is engaged with the smallest sprocket on the rear-wheel assembly. The torque exerted on the rear wheel by the chain is then relatively small because of the small lever arm. The wheel turns several times, however, for each turn of the pedal sprocket. If, for example, the radius of the pedal sprocket is five times that of the rear-wheel sprocket, then the rear wheel turns five times for each turn of the pedal crank. (The circumference of each sprocket  $[2\pi r]$  is proportional to the radius, and the circumference determines how far the chain must travel for each turn.)

In this case, then, a small torque turns the rear wheel through a large angle, while a larger input torque turns the pedal sprocket through a smaller angle. By analogy to linear work (force times distance moved), rotational work can be defined as the torque times the angle through which the sprocket turns ( $\tau\theta$ ). As for any simple machine, the work output equals the work input, ignoring frictional torques at the wheel axles.

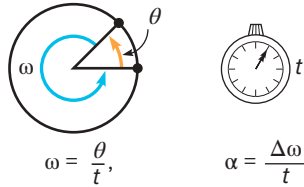
Would the situation we have just described represent a high gear or a low gear? Because we are getting several turns of the rear wheel for each turn of the pedal crank, this is a high gear. For a lower gear, we need to move the chain to a larger sprocket on the rear wheel (or a smaller sprocket on the pedal wheel). This will transmit a larger torque to the rear wheel at the expense of turning the wheel through a smaller angle and moving the bicycle through a smaller distance for each turn of the crank. When we are going uphill, we need this larger torque to overcome the pull of gravity.

For a 21-speed bike, there are three sprocket sizes on the pedal wheel and seven on the rear wheel, allowing 21 ( $3 \times 7$ ) different ratios between the two sprockets. The advantage of having all these choices is that we can adjust the mechanical advantage of our gear system to the conditions we encounter, thus adjusting the force we need to apply to the pedals to achieve the desired torque. If this force is too large, we will quickly tire. When it is small, however, we may not be taking maximum advantage of the easier riding conditions. We can go faster in a higher gear.

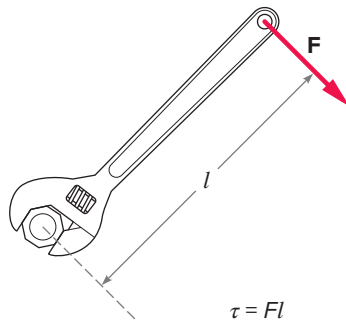
## Summary

We have considered the rotational motion of a solid object and what causes changes in rotational motion. We have used an analogy between linear motion and rotational motion to develop many of the concepts. The key points are the following:

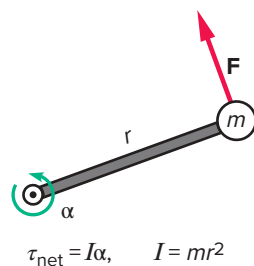
**1 What is rotational motion?** Rotational displacement is described by an angle. Rotational velocity is the rate of change of that angle with time. Rotational acceleration is the rate of change of rotational velocity with time.



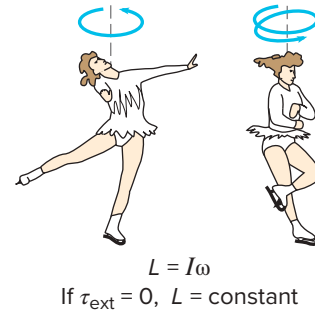
**2 Torque and balance.** A torque is what causes an object to rotate. It is defined as a force times the lever arm of the force, which is the perpendicular distance from the line of action of the force to the axis of rotation. If the net torque acting on an object is zero, the object will not change its state of rotation.



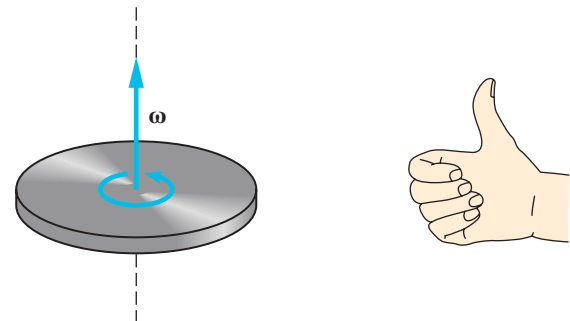
**3 Rotational inertia and Newton's second law.** In the form of Newton's second law that relates to rotation, torque takes the place of force, rotational acceleration replaces ordinary linear acceleration, and rotational inertia replaces mass. Rotational inertia depends on the distribution of mass about the axis of rotation.



**4 Conservation of angular momentum.** By analogy to linear momentum, angular momentum is defined as the rotational inertia times the rotational velocity. It is conserved when no net external torque acts on the system.



**5 Riding a bicycle and other amazing feats.** The directions of the rotational-velocity and angular-momentum vectors are defined by the right-hand rule. These vectors explain the stability of a moving bicycle and other phenomena. If there are no external torques, the direction of the angular momentum is conserved, as well as its magnitude.



The notation used in this chapter may seem like so much Greek to you, but the equations are very similar to the ones you learned earlier with linear motion. It will help if you use the units to identify the variables in the problems. Try the practice problems in Connect. They have complete solutions, which you should look at *after* you try the problems!

## Key Terms

Rotational velocity, 146  
Rotational displacement, 146  
Radian, 146  
Linear displacement, 146  
Rotational acceleration, 147

Fulcrum, 149  
Torque, 150  
Lever arm, 150  
Center of gravity, 151  
Rotational inertia, 153

Moment of inertia, 153  
Angular momentum, 156  
Conservation of angular momentum, 156  
Right-hand rule, 158



## Conceptual Questions

\* = more open-ended questions, requiring lengthier responses, suitable for group discussion

Q = sample responses are available in appendix D

Q = sample responses are available in Connect

Q1. Which units would not be appropriate for describing a rotational velocity:  $\text{rad}/\text{min}^2$ ,  $\text{rev}/\text{s}$ ,  $\text{rev}/\text{h}$ ,  $\text{m}/\text{s}$ ? Explain.

Q2. Which units would not be appropriate for describing a rotational acceleration:  $\text{rad}/\text{s}$ ,  $\text{rev}/\text{s}^2$ ,  $\text{rev}/\text{m}^2$ ,  $\text{degrees}/\text{s}^2$ ? Explain.

Q3. A coin rolls down an inclined plane, gaining speed as it rolls. Does the coin have a rotational acceleration? Explain.

Q4. The rate of rotation of an object is gradually slowing down. Does this object have a rotational acceleration? Explain.

Q5. Is the rotational velocity of a child sitting near the center of a rotating merry-go-round the same as that of another child sitting near the edge of the same merry-go-round? Explain.

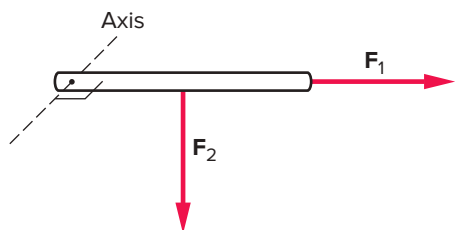
Q6. Is the linear speed of a child sitting near the center of a rotating merry-go-round the same as that of another child sitting near the edge of the same merry-go-round? Explain.

Q7. If an object has a constant rotational acceleration, is its rotational velocity also constant? Explain.

\*Q8. A ball rolls down an inclined plane, gaining speed as it goes. Does the ball experience both linear and rotational acceleration? How far does the ball travel in 1 revolution? How is the linear velocity of the ball related to its rotational velocity? Explain.

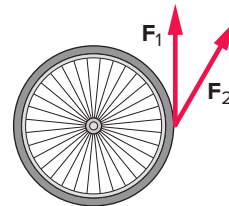
Q9. Which, if either, will produce the greater torque: a force applied at the end of a wrench handle (perpendicular to the handle) or an equal force applied in the same direction near the middle of the handle? Explain.

Q10. Which of the forces pictured as acting upon the rod in the diagram will produce a torque about an axis perpendicular to the plane of the diagram at the left end of the rod? Explain.



Q10 Diagram

Q11. The two forces in the diagram have the same magnitude. Which orientation will produce the greater torque on the wheel? Explain.



Q11 Diagram

Q12. Is it possible to balance two objects of different weights on the beam of a simple balance resting upon a fulcrum? Explain.

\*Q13. Is it possible for the net force acting on an object to be zero but the net torque to be greater than zero? Explain. (Hint: The forces contributing to the net force may not lie along the same line.)

Q14. You are trying to move a large rock using a steel rod as a lever. Will it be more effective to place the fulcrum nearer to your hands or nearer to the rock? Explain.

Q15. A pencil is balanced on a fulcrum located two-thirds of the distance from one end. Is the center of gravity of this pencil located at its center point? Explain.

Q16. A solid plank with a uniform distribution of mass along its length rests on a platform with one end of the plank protruding over the edge. How far out can we push the plank before it tips? Explain.

\*Q17. A uniform metal wire is bent into the shape of an L. Will the center of gravity for the wire lie on the wire itself? Explain.

Q18. An object is rotating with a constant rotational velocity. Can there be a net torque acting on the object? Explain.

\*Q19. A tall crate has a higher center of gravity than a shorter crate. Which will have the greater tendency to tip over if we push near the top of the crate? Explain with a force diagram. Where is the probable axis of rotation?

Q20. Two objects have the same total mass, but object A has its mass concentrated closer to the axis of rotation than object B. Which object will be easier to set into rotational motion? Explain.

Q21. Is it possible for two objects with the same mass to have different rotational inertias? Explain.

Q22. Can you change your rotational inertia about a vertical axis through the center of your body without changing your total weight? Explain.

Q23. A solid sphere and a hollow sphere made from different materials have the same mass and the same radius. Which

bottom of the string? Explain. (See everyday phenomenon box 8.1.)

Q22. Can a yo-yo be made to "sleep" if the string is tied tightly to the axle? Explain. (See everyday phenomenon box 8.1.)

Q33. An ice skater is spinning counterclockwise about a vertical axis when viewed from above. What is the direction of her angular-momentum vector? Explain.

Q34. A pencil, balanced vertically on its eraser, falls to the right. What is the direction of its angular-momentum vector as it falls?

b. Is its angular momentum conserved during the fall? Explain.

\*Q35. A top falls over quickly if it is not spinning but will stay approximately upright for some time when it is spinning. Explain why this is so.

Q36. When we shift gears on the rear-wheel gear of a bicycle, does the torque applied to that wheel change? Explain. (See everyday phenomenon box 8.2.)

Q37. In what foot position do we exert maximum torque on a bicycle pedal? Explain. (See everyday phenomenon box 8.2.)

Q38. If we move the chain to a larger sprocket on the rear-wheel gear of a bicycle, are we changing to a higher or a lower gear? Explain. (See everyday phenomenon box 8.2.)

## EXERCISES

of these two objects, if either, will have the greater rotational inertia about an axis through its center? Explain.

Q24. Is angular momentum always conserved? Explain.

Q25. A metal rod is rotated first about an axis through its center and then about an axis passing through one end. If the rotational velocity is the same in both cases, is the angular momentum also the same? Explain.

Q26. A child on a freely rotating merry-go-round moves from near the center to the edge. Will the rotational velocity of the merry-go-round increase, decrease, or not change at all? Explain.

\*Q27. Moving straight inward, a large child jumps onto a freely rotating merry-go-round. What effect will this have on the rotational velocity of the merry-go-round? Explain.

Q28. Is it possible for an ice skater to change his rotational velocity without involving any external torque? Explain.

Q29. Suppose you are rotating a ball attached to a string in a circle. If you allow the string to wrap around your finger, does the rotational velocity of the ball change as the string shortens? Explain.

Q30. Does the direction of the angular-momentum vector of the wheels change when a bicycle goes around a corner? Explain.

Q31. Does the direction of the angular momentum vector change when a yo-yo starts to move upward having reached the

E1. Suppose a merry-go-round is rotating at the rate of 8 rev/min.

a. Express this rotational velocity in rev/s.

b. Express this rotational velocity in rad/s.

E2. At one time, the rate of rotation for popular music records on a record player was 33 rpm.

a. Express this rotational velocity in rev/s.

b. Through how many revolutions does the record turn in a time of 5 s?

E3. Suppose a disk rotates through 8 revolutions in 5 seconds.

a. What is its displacement in radians in this time?

b. What is its average rotational velocity in rad/s?

E4. A bicycle wheel is rotationally accelerated at the constant rate of 1.3 rev/s<sup>2</sup>.

a. If it starts from rest, what is its rotational velocity after 5 s?

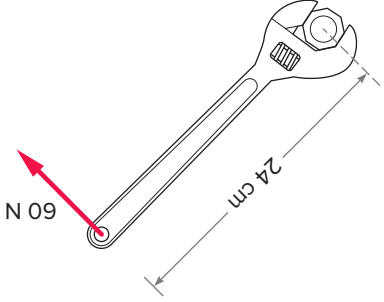
b. Through how many revolutions does it turn in this time?

E5. The rotational velocity of a merry-go-round increases at a constant rate from 0.3 rad/s to 2.1 rad/s in a time of 6 s. What is the rotational acceleration of the merry-go-round?

E6. The rotational velocity of a spinning disk decreases from 14 rev/s to 3 rev/s in a time of 15 s. What is the rotational acceleration of the disk?

E9. A weight of 40 N is located a distance of 8 cm from the fulcrum of a simple balance beam. At what distance from the fulcrum should a weight of 25 N be placed on the opposite side in order to balance the system?

**E8 Diagram**



way up the handle instead of at the end?

b. What would the torque be if the force were applied half-

a. What is the torque applied to the nut by the wrench?

E8. A force of 60 N is applied at the end of a wrench handle that is 24 cm long. The force is applied in a direction perpendicular to the handle, as shown in this question's diagram.

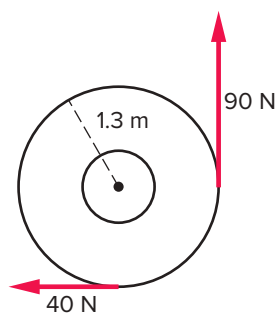
b. How many revolutions occur during this time?

a. What is its rotational velocity after 6 s?

stant rate of 0.4 rev/s<sup>2</sup>.

E7. Starting from rest, a merry-go-round accelerates at a con-

- E10. A weight of 8 N is located 12 cm from the fulcrum on the beam of a simple balance. What weight should be placed at a point 5 cm from the fulcrum on the opposite side in order to balance the system?
- E11. Two forces are applied to a merry-go-round with a radius of 1.3 m, as shown in this question's diagram. One force has a magnitude of 90 N and the other a magnitude of 40 N.
- What is the torque about the axle of the merry-go-round due to the 90-N force?
  - What is the torque about the axle due to the 40-N force?
  - What is the net torque acting on the merry-go-round?

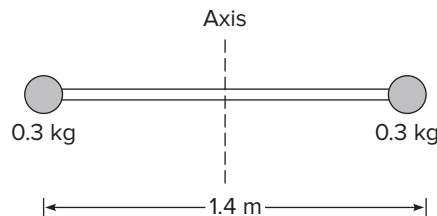


E11 Diagram

- E12. A net torque of 93.5 N·m is applied to a disk with a rotational inertia of 11.0 kg·m<sup>2</sup>. What is the rotational acceleration of the disk?
- E13. A wheel with a rotational inertia of 8.3 kg·m<sup>2</sup> accelerates at a rate of 4.0 rad/s<sup>2</sup>. What net torque is needed to produce this acceleration?
- E14. A torque of 76 N·m producing a counterclockwise rotation is applied to a wheel about its axle. A frictional torque of 14 N·m acts at the axle.

- What is the net torque about the axle of the wheel?
- If the wheel accelerates at the rate of 6 rad/s<sup>2</sup> under the influence of these torques, what is the rotational inertia of the wheel?

- E15. Two 0.3-kg masses are located at either end of a 1.4-m long, very light and rigid rod, as shown in this question's diagram. What is the rotational inertia of this system about an axis through the center of the rod?



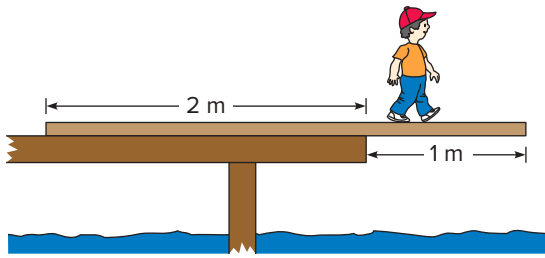
E15 Diagram

- E16. A mass of 0.75 kg is located at the end of a very light and rigid rod 60 cm in length. The rod is rotating about an axis at its opposite end with a rotational velocity of 12 rad/s.
- What is the rotational inertia of the system?
  - What is the angular momentum of the system?
- E17. A uniform disk with a mass of 7 kg and a radius of 0.4 m is rotating with a rotational velocity of 15 rad/s.
- What is the rotational inertia of the disk? (See fig. 8.15.)
  - What is the angular momentum of the disk?
- E18. A student, sitting on a stool holds a mass in each hand. When his arms are extended, the total rotational inertia of the system is 5.6 kg·m<sup>2</sup>. When he pulls his arms in close to his body, he reduces the total rotational inertia to 1.4 kg·m<sup>2</sup>. When he is rotating with his hands held close to his body, his rotational velocity is 48 rpm. If there are no external torques, what is the rotational velocity of the system when he extends his arms?

## Synthesis Problems

- SP1. A merry-go-round has a radius of 1.5 m and a rotational inertia of 800 kg·m<sup>2</sup>. A child pushes the merry-go-round with a constant force of 92 N applied at the edge and parallel to the edge. A frictional torque of 14 N·m acts at the axle of the merry-go-round.
- What is the net torque acting on the merry-go-round about its axle?
  - What is the rotational acceleration of the merry-go-round?
  - At this rate, what will the rotational velocity of the merry-go-round be after 16 s if it starts from rest?
  - If the child stops pushing after 16 s, the net torque is now due solely to the friction. What then is the rotational acceleration of the merry-go-round? How long will it take for the merry-go-round to stop turning?
- SP2. A 3-m-long plank with a weight of 130 N is placed on a dock with 1 m of its length extended over the water, as in the diagram. The plank is uniform in density, so that the center of gravity of the plank is located at the center of the plank. A boy with a weight of 180 N is standing on the plank and moving out slowly from the edge of the dock.
- How far from the pivot point at the edge of the dock is the center of the plank?
  - What is the torque exerted by the weight of the plank about the pivot point at the edge of the dock? (Treat all the weight as acting through the center of gravity of the plank.)
  - How far from the edge of the dock can the boy move until the plank is just on the verge of tipping?

- d. How can the boy test this conclusion without falling into the water? Explain.



SP2 Diagram

- SP3. Several children (having a total mass of 90 kg) are riding on a merry-go-round that has a rotational inertia of  $1100 \text{ kg}\cdot\text{m}^2$  and a radius of 2.4 m. The average distance of the children from the axle of the merry-go-round is 2.2 m initially, because they are all riding near the edge.
- What is the rotational inertia of the children about the axle of the merry-go-round? What is the total rotational inertia of the children and the merry-go-round?
  - The children now move inward toward the center of the merry-go-round, so that their average distance from the axle is 0.8 m. What is the new rotational inertia for the system?
  - If the initial rotational velocity of the merry-go-round was 1.3 rad/s, what is the rotational velocity after the children move in toward the center, assuming that the frictional torque can be ignored? (Use conservation of angular momentum.)
  - Is the merry-go-round rotationally accelerated during this process? If so, where does the accelerating torque come from?

- SP4. A student sitting on a stool that is free to rotate, but is initially at rest, holds a bicycle wheel. The wheel has a rotational velocity of 8 rev/s about a vertical axis, as shown in the SP4 diagram. The rotational inertia of the wheel is  $2.5 \text{ kg}\cdot\text{m}^2$  about its center, and the rotational inertia of the student, wheel, and stool about the rotational axis of the stool is  $6 \text{ kg}\cdot\text{m}^2$ .
- What is the rotational velocity of the wheel in rad/s?
  - What are the magnitude and direction of the initial angular momentum of the system?
  - If the student flips the axis of the wheel, reversing the direction of its angular-momentum vector, what is the rotational velocity (magnitude and direction) of the student and the stool about their axis after the wheel is flipped? (Hint: See fig. 8.24.)
  - Where does the torque come from that accelerates the student and the stool? Explain.



SP4 Diagram

## Home Experiments and Observations

- HE1. If there is a park nearby containing a freely rotating child's merry-go-round, take some time with a friend to observe some of the phenomena discussed in this chapter. In particular, make these observations:
- What is a typical rotational velocity that can be achieved with the merry-go-round? How would you go about measuring this?
  - How long does it take for the merry-go-round to come to rest after you stop pushing? Could you estimate the frictional torque from this information? What other information would you need?
  - If you or your friend is riding on the merry-go-round, what happens to the rotational velocity when you move inward or outward from the axis of the merry-go-round? How do you explain this?
- HE2. Create a simple balance using a ruler as the balance beam and a pencil as the fulcrum. (A pencil or pen with a hexagonal cross section is easier to use than one with a round cross section.)
- Does the ruler balance exactly at its midpoint? What does this imply about the ruler?
  - Using a nickel as your standard, what are the ratios of the weights of pennies, dimes, and quarters to that of the nickel? Describe the process used to find these ratios.
  - Is the distance from the fulcrum necessary to balance two nickels on one side with a single nickel on the opposite side exactly half the distance for the single nickel? How would you account for any discrepancy?
- HE3. You can make a simple top by cutting a circular piece of cardboard, poking a hole through the center, and using a short, dull pencil for the post. A short, wooden dowel with a rounded end works even better than a pencil.
- Try building such a top and testing it. How far up the pencil should the cardboard disk sit for best stability?
  - Observe what happens to the axis of rotation of the top as it slows down. What is the direction of the angular-momentum vector, and how does it change?

- c. What happens to the stability of your top if you tape two pennies near the edge on opposite sides of the cardboard disk?
- HE4. Try spinning a quarter or other large coin about its edge on a smooth tabletop or other similar surface. Describe the motion that follows, paying particular attention to the direction of the angular-momentum vector.
- HE5. As described in the study hint in section 8.5, use a bicycle wheel mounted on a handheld axle (probably available from your friendly physics department) to study the angular momentum vectors and their changes. In particular, make these observations:
- Grasp the wheel with both hands by the handles on each side and have someone give it a good spin with the wheel in a vertical plane. Then, try tilting the wheel downward to the left to simulate a fall. What direction does the wheel turn? Describe what happens.
  - Grasp the wheel with both hands by the handles on each side and hold it in the vertical orientation. Without spinning the wheel, rotate it into the horizontal plane. Now repeat this, but first have someone give it a good spin with the wheel in the vertical plane. Is it harder or easier to rotate it into the horizontal plane when the wheel is spinning? Explain how this can be related to riding a bicycle.

# UNIT 2

## Fluids and Heat

**E**nergy issues have become increasingly important as the worldwide oil supply tightens. Although Newton's theory of mechanics was introduced in the seventeenth century, the physics underlying our understanding of energy utilization did not make great strides until the nineteenth century. Some of these developments, particularly in the fields of fluid mechanics and thermodynamics, were stimulated by the industrial revolution. This revolution could not have happened without the invention of steam engines, which were used to run factories, trains, and ships.

Understanding the behavior of fluids, particularly gases, is critical to our understanding of many kinds of engines, including steam engines. Thermodynamics is also crucial because it describes the energy conversions that take place in heat engines and other systems. The study of fluid mechanics and thermodynamics is a central part of the training of the mechanical engineers who design these systems.

The history of the field of thermodynamics has taken some strange twists and turns. A French scientist and engineer, Sadi Carnot (1796–1832), developed a theory of heat engines around 1820, but Carnot's theory raised more questions than it answered. Carnot had some understanding of what we now call the second law of thermodynamics, but he lacked the crucial insights of the first law. The first law involves conservation of energy, but that idea came into its own only around 1850, about 30 years later. A comprehensive theory had to wait until then for the insights that resulted from combining the first and second laws of thermodynamics.

The first and second laws of thermodynamics emerged during the 1850s through the work of many scientists,



Aleksandr Riutin/Shutterstock

most prominently Rudolph Clausius (1822–1888) and William Thompson (later Lord Kelvin) (1824–1907). Another important contributor was James Prescott Joule (1818–1889), who measured the heating effect of mechanical work, a key idea in the first law of thermodynamics. Together, the first and second laws of thermodynamics place limits on what can be accomplished with energy in the form of heat.

The laws of thermodynamics play an enormous role in any discussion of the use of energy resources. Energy is still a critical issue—our heavy dependence on fossil fuels cannot go on indefinitely. Concerns about global warming (associated with the greenhouse effect) and other environmental issues related to energy use have become hot political issues. Understanding the science underlying these issues is important for economists, politicians, environmentalists, and citizens in general. Chapters 9, 10, and 11 address these ideas.



# CHAPTER 9

Jupiterimages/Stockbyte/Getty Images

## The Behavior of Fluids

### Chapter Overview

Our first objective in this chapter is to explore the meaning of pressure. We then investigate atmospheric pressure and how pressure varies with depth in a fluid. Those ideas will prepare us to explore the behavior of floating objects, as well as what happens when fluids are in motion. Moving fluids are described by Bernoulli's principle, which helps us to explain why a curveball curves and many other phenomena.

### Chapter Outline

- 1 Pressure and Pascal's principle.** What is pressure? How is it transmitted from one part of a system to another? How does a hydraulic jack or press work?
- 2 Atmospheric pressure and the behavior of gases.** How do we measure atmospheric pressure, and why does it vary? Why can we compress gases more readily than liquids? What is Boyle's law?
- 3 Archimedes' principle.** What is Archimedes' principle? How is it related to differences in pressure? Why does a steel boat float but a lump of steel sink?
- 4 Fluids in motion.** What special characteristics can we observe in moving fluids? What is viscosity? How does the velocity of a moving fluid vary if we change the width of its pipe or stream?
- 5 Bernoulli's principle.** What is Bernoulli's principle, and how is it related to conservation of energy? How can Bernoulli's principle be used to explain the motion of a curveball and other phenomena?

**B**oats hold a special fascination for many of us. As a child, you probably floated twigs or sticks in streams. A stick or toy boat will follow the current of a stream, sometimes moving swiftly and other times getting caught in an eddy or stranded near the bank. These are some characteristics of fluid flow.

You have probably also noticed that some things float and some do not. Stones sink quickly to the bottom of a stream. As you grew older, you may have wondered why a steel boat floats, while a piece of metal dropped in the water quickly sinks (fig. 9.1). Does the shape of the material have something to do with whether it floats or not? Can you make a boat of concrete?

Things can float in air as well as in water. A balloon filled with helium pulls up on the string, but a balloon filled with air drifts down to the floor. What makes the difference?

The behavior of things that float (or sink) in water or air is one aspect of the behavior of fluids. Fluids flow readily and conform to the shapes of their containers, unlike solids, which have shapes of their own. Water and air are both examples of fluids, although one is a liquid and the other a gas. Although liquids are usually much denser than gases, many of the principles that apply to liquids also apply to gases, so it makes



**Figure 9.1** A steel boat floats, but a piece of metal dropped in the water quickly sinks. How do we explain this?

(left): appletat/iStock/Getty Images; (right): Jill Braaten/McGraw-Hill Education

sense to consider them together under the common heading of fluids.

Pressure plays a central role in describing the behavior of fluids. We will explore pressure thoroughly in this chapter. Pressure is involved in Archimedes' principle, which explains how things float, but pressure is also important in other phenomena we will consider, including the flow of fluids.

## 9.1 Pressure and Pascal's Principle

A small woman wearing high-heeled shoes sinks into soft ground, but a large man wearing size-13 shoes may walk across the same ground without difficulty (fig. 9.2). Why is this so? The man weighs much more than the woman, so he must exert a larger force on the ground. But the woman's high heels leave much deeper indentations in the ground.

Clearly, weight alone is not the determining factor. How the force is distributed across the area of contact between the shoes and the Earth is more important. The woman's shoes have a small area of contact, while the man's shoes have a much larger area of contact. The force exerted on the ground by the man's feet due to his weight is distributed over a larger area.

### How is pressure defined?

What is happening when you stand or walk on soft ground? If you are not accelerating in the vertical direction, your



**Figure 9.2** A woman's high heels sink into the soft ground, but the larger shoes of the much bigger man do not.

weight must be balanced by the normal force exerted upward on your feet by the ground. By Newton's third law, you exert a downward normal force on the ground equal to your weight.

The quantity that determines whether the soil will yield, letting your shoes sink into the ground, is the **pressure** exerted on the soil by your shoes. The total normal force does not matter as much as the force per unit area:

The average pressure is the ratio of the perpendicular force to the area over which it is applied:

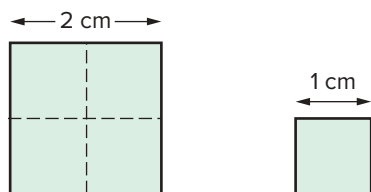
$$P = \frac{F}{A}$$

Pressure is measured in units of newtons per meter squared ( $\text{N/m}^2$ )—the metric unit of force divided by the metric unit of area. This unit is also called a pascal ( $1 \text{ Pa} = 1 \text{ N/m}^2$ ).

The heel area of a woman's high-heeled shoe can be as small as just 1 or 2 square centimeters ( $\text{cm}^2$ ). When you walk, there are times when almost all of your weight is supported by your heel. The weight shifts from heel to toe as you move forward with your other foot off the ground. Take a few steps to test this statement. The woman's weight divided by the small area of her heel produces a large pressure on the ground.

The man's shoe, on the other hand, may have a heel area of as much as  $100 \text{ cm}^2$  (for a size-13 shoe). Because his heel area may be 100 times larger than the woman's heel, he can weigh two or three times as much as the woman yet exert a pressure on the ground ( $P = F/A$ ) that is a small fraction of the pressure exerted by the woman. His smaller pressure leads to a smaller indentation in the ground.





**Figure 9.3** A square with sides 2 cm long has an area that is four times as large as a square with sides 1 cm long.

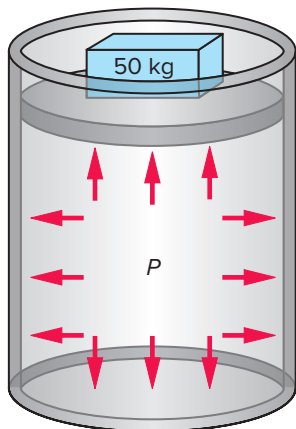
The area over which a force is distributed is the critical factor in pressure. The area of a surface increases more rapidly than the linear dimensions of the surface. A square that is 1 cm on each side has an area of  $1 \text{ cm}^2$ , for example, but a square that is 2 cm on a side has an area of  $4 \text{ cm}^2$  ( $2 \text{ cm} \times 2 \text{ cm}$ ), four times as large as the smaller square (fig. 9.3). For a circle, the area is equal to  $\pi$  times the square of the radius of the circle ( $A = \pi r^2$ ). A circle with a radius of 10 cm has an area 100 times larger ( $10^2$ ) than a circle with a radius of 1 cm.

### Pascal's principle

What happens inside a fluid when pressure is exerted on it? Does pressure have direction? Does it transmit a force to the walls or bottom of a container? These questions point to another important feature of pressure in fluids.

When we apply a force by pushing down on the piston in a cylinder, as in figure 9.4, the piston exerts a force (in the opposite direction) on the fluid. By Newton's third law, the fluid also exerts a force (in the opposite direction) on the piston. The fluid inside the cylinder will be squeezed and may decrease in volume somewhat. It has been *compressed*. Like a compressed spring, the compressed fluid will push outward on the walls and bottom of the cylinder, as well as on the piston.

Although the fluid behaves like a spring, it is an unusual spring. It pushes outward *uniformly* in all directions when compressed. Any increase in pressure is transmitted



**Figure 9.4** The pressure exerted on the piston extends uniformly throughout the fluid, causing it to push outward with equal force per unit area on the walls and bottom of the cylinder.

uniformly throughout the fluid, as figure 9.4 indicates. If we ignore variations in pressure due to the weight of the fluid itself, the pressure that pushes upward on the piston is equal to the pressure that pushes outward on the walls and downward on the bottom of the cylinder.

The ability of a fluid to transmit the effects of pressure uniformly is the core of Pascal's principle and the basis of the operation of a hydraulic jack and other hydraulic devices. Blaise Pascal (1623–1662) was a French scientist and philosopher whose primary contributions were in the areas of fluid statics and probability theory. **Pascal's principle** is usually stated like this:

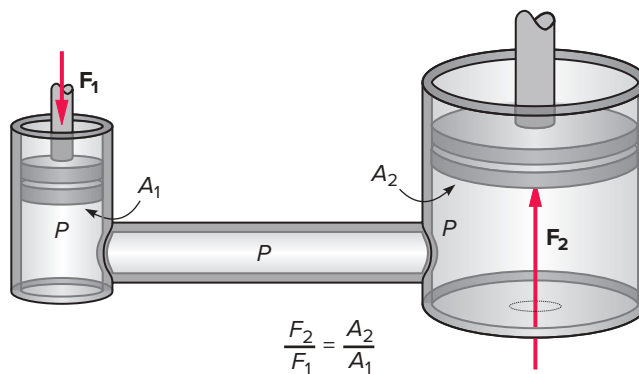
Any change in the pressure of an enclosed fluid at rest is transmitted uniformly to all points in the fluid.

### How does a hydraulic jack work?

- ▶ Hydraulic systems are the most common applications of Pascal's principle. They depend on the uniform transmission of pressure, as well as on the relationship between pressure, force, and area stemming from the definition of pressure. The basic idea is illustrated in figure 9.5.

A force applied to a piston with a small area can produce a large increase in pressure in the fluid because of the small area of the piston. This increase in pressure is transmitted through the fluid to the piston on the right in figure 9.5, which has a much larger area. Because pressure is force per unit area, the force exerted on the larger piston by this pressure is proportional to the area of the piston ( $F = PA$ ). Applying the same pressure to the much larger area of the second piston results in a much larger force on the second piston.

Because it is feasible to build a system in which the area of the second piston is more than 100 times larger than the first piston, we can produce a force on the second piston more than 100 times larger than the input force. The mechanical advantage, the ratio of the output force to the input



**Figure 9.5** A small force  $F_1$  applied to a piston with a small area produces a much larger force  $F_2$  on the larger piston. This allows a hydraulic jack to lift heavy objects.



**Figure 9.6** A hydraulic jack can easily lift a car.  
Mitch York/Stone/Getty Images

force, of a hydraulic system will usually be large compared to that of a lever or other simple machine. (See section 6.1.) A small force applied to the input piston of a hydraulic jack can be multiplied to produce a force large enough to lift a car (fig. 9.6). These ideas are illustrated in example box 9.1.

As discussed in chapter 6, we pay a price for getting a larger output force. The work done by the larger piston in lifting the car cannot be any greater than the work input to the handle of the jack. Because work is equal to force times distance ( $W = Fd$ ), a large output force means that the larger piston moves just a small distance. Conservation of energy requires that if the output force is 50 times larger than the input force, the input piston must move 50 times farther than the output piston.

With a hand-pumped hydraulic jack, you have to move the smaller piston several times, letting the jack's chamber refill with fluid after each stroke. The total distance moved by the smaller piston is the sum of the distances moved on each stroke. The larger piston inches upward as you pump. A similar process occurs in larger hydraulic jacks.

Hydraulic systems and fluid are also used in the brake systems of cars and in many other applications. Oil is more effective than water as a hydraulic fluid, because it is not corrosive and can lubricate, ensuring smooth

Pressure is the ratio of the force to the area over which it is applied. A force applied to a small area exerts a much larger pressure than the same force applied to a larger area. Changes in pressure are transmitted uniformly through a fluid, and the pressure pushes outward in all directions, according to Pascal's principle. These ideas explain the operation of a hydraulic jack and other hydraulic systems.

## Example Box 9.1

### Sample Exercise: Some Basics of Jacks

A force of 10 N is applied to a circular piston with an area of  $2 \text{ cm}^2$  in a hydraulic jack. The output piston for the jack has an area of  $100 \text{ cm}^2$ .

- What is the pressure in the fluid?
- What is the force exerted on the output piston by the fluid?

$$\begin{aligned} \text{a. } F_1 &= 10 \text{ N} & P &= \frac{F_1}{A_1} \\ A_1 &= 2 \text{ cm}^2 & &= \frac{10 \text{ N}}{0.0002 \text{ m}^2} \\ & & &= 2 \text{ cm}^2 \left( \frac{1 \text{ m}}{100 \text{ cm}} \right)^2 & &= 50,000 \text{ N/m}^2 \\ & & &= 2 \text{ cm}^2 \left( \frac{1 \text{ m}^2}{10,000 \text{ cm}^2} \right) & &= \mathbf{50 \text{ kPa}} \\ & & &= 0.0002 \text{ m}^2 \\ P &= ? \end{aligned}$$

A kilopascal (kPa) is 1000 Pa, or  $1000 \text{ N/m}^2$ .

$$\begin{aligned} \text{b. } A_2 &= 100 \text{ cm}^2 & F_2 &= PA_2 \\ &= 0.01 \text{ m}^2 & &= (50,000 \text{ N/m}^2)(0.01 \text{ m}^2) \\ P &= 50 \text{ kPa} & &= \mathbf{500 \text{ N}} \\ F_2 &= ? \end{aligned}$$

The mechanical advantage of this jack is 500 N divided by 10 N, or 50: The output force is 50 times *larger* than the input force.

operation of the system. Hydraulic systems take good advantage of the ability of fluids to transmit changes in pressure, as described by Pascal's principle. They also use the multiplying effect produced by pistons of different areas. A hydraulic system is a good example of the concept of pressure in action.

## 9.2 Atmospheric Pressure and the Behavior of Gases

Living on the surface of the Earth, we are at the bottom of a sea of air. Except for smog or haze, air is usually invisible. We seldom give it a second thought. How do we know it is there? What measurable effects does it have?

We feel the presence of air, of course, when riding a bike or walking on a gusty day. Skiers, bicycle racers, and car designers are all conscious of the need to reduce resistance to the flow of air past themselves and their vehicles. The labored breathing of a mountain climber is partly due to the thinning of the atmosphere near the top of a high mountain.

How do we measure **atmospheric pressure** and its variations with weather or altitude?

### How is atmospheric pressure measured?

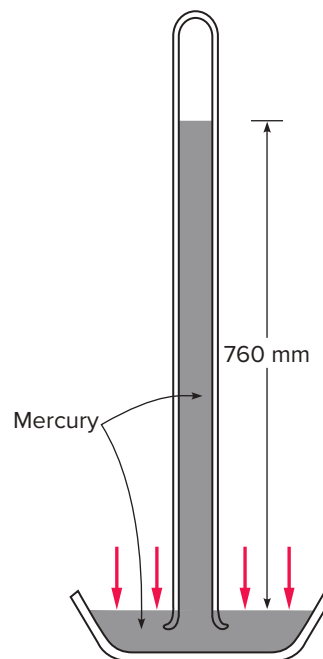
Atmospheric pressure was first measured during the seventeenth century. Galileo noticed that the water pumps he designed were capable of pumping water to a height of only 32 feet, but he never adequately explained why. His disciple, Evangelista Torricelli (1608–1647), invented the barometer as he attempted to answer this question.

Torricelli was interested in vacuums. He reasoned that Galileo's pumps created a partial vacuum and that the pressure of the air pushing down on the water at the pump intake was responsible for lifting the water. In thinking about how to test this hypothesis, he was struck by the idea of using a much denser fluid than water. Mercury (historically called quicksilver) was the logical choice, because it is a fluid at room temperature and has a density approximately 13 times that of water. A given volume of mercury therefore has a mass (and weight) that is 13 times an equal volume of water. Densities of a few common substances are listed in table 9.1.

**Density** is the mass of an object divided by its volume. The metric units of density are  $\text{kg/m}^3$  and  $\text{g/cm}^3$ .

In his early experiments, Torricelli used a glass tube about 1 meter in length, sealed at one end and open at the other. He filled the tube with mercury and then, holding his finger over the open end, inverted the tube and placed this end in the open container of mercury (fig. 9.7). The mercury flowed from the tube into the container until an equilibrium was reached, leaving a column of mercury in the tube approximately 760 mm (76 cm, or 30 in) high. The pressure of air pushing down on the surface of the mercury in the open container apparently was strong enough to support a column of mercury 760 mm high.

Torricelli was careful to demonstrate experimentally that there was a vacuum in the space at the top of the tube above the column of mercury. The reason the mercury



**Figure 9.7** Torricelli filled a tube with mercury and inverted it into an open container of mercury. Air pressure acting on the mercury in the dish can support a column of mercury 760 mm in height.

column does not fall is that the pressure at the top of the column is effectively zero, while the pressure at the bottom of the column is equal to atmospheric pressure. We still often quote atmospheric pressure in either millimeters of mercury or inches of mercury (the commonly used unit in the United States). How are these units related to the pascal?

We can establish the relationship between these units if we know the density of mercury. From this, we can find the weight of the column of mercury being supported by the atmosphere. Dividing this weight by the cross-sectional area of the tube gives us force per unit area, or pressure. Using this reasoning, we find that a column of mercury 760 mm in height produces a pressure of  $1.01 \times 10^5$  Pa, known as standard atmospheric pressure.

Atmospheric pressure is approximately 100 kilopascals (kPa) at sea level, or 14.7 pounds per square inch (psi). (Pounds per square inch is the British unit of pressure still used in the United States for measuring tire pressure and many other pressures of practical interest; 1 psi = 6.9 kPa.) Living at the bottom of this sea of air, you have 14.7 pounds pushing on you for every square inch of your body. Why do you not notice this? Fluids permeate your body and push back out—the interior and exterior pressures are essentially equal. (See everyday phenomenon box 9.1.)

A famous experiment designed to demonstrate the effects of air pressure was performed by Otto von Guericke (1602–1686). Von Guericke designed two bronze hemispheres that could be smoothly joined together at their rims.

**Table 9.1**

Densities of Some Common Substances

Material	Density ( $\text{g/cm}^3$ )
Water	1.00
Ice	0.92
Aluminum	2.7
Iron, steel	7.8
Mercury	13.6
Gold	19.3

## Everyday Phenomenon

## Box 9.1

## Measuring Blood Pressure

**The Situation.** When you visit your doctor's office, the nurse will almost always take your blood pressure before the doctor spends time with you. A cuff is placed around your upper arm (as shown in the photograph) and air is pumped into the cuff, producing a feeling of tightness in your arm. Then, the air is slowly released while the nurse listens to something with a stethoscope and records some numbers, such as 125 over 80.



Having your blood pressure measured is a standard procedure for most visits to a doctor's office. How does this process work?

*Comstock/Stockbyte/Getty Images*

What is the significance of these two numbers? What is blood pressure, and how is it measured? Why are these readings an important factor, along with your weight, temperature, and medical history, in assessing your health?

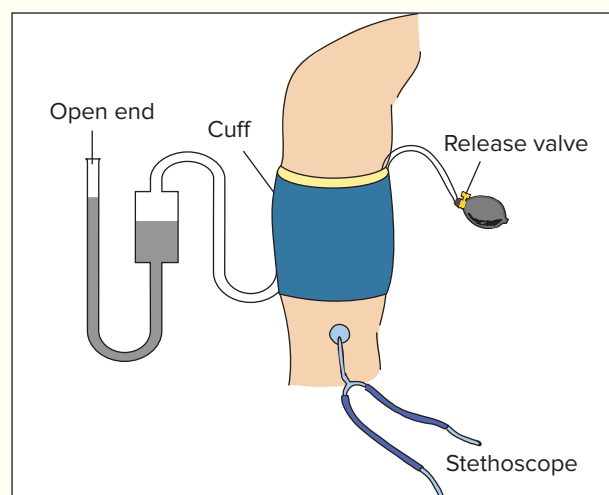
**The Analysis.** Your blood flows through an elaborate system of arteries and veins in your body. As we all know, this flow is driven by your heart, which is basically a pump. More accurately, the heart is a double pump. One-half pumps blood through your lungs, where the blood cells pick up oxygen and discard carbon dioxide. The other half of the heart pumps blood through the rest of your body to deliver oxygen and nutrients. Arteries carry blood away from the heart into small capillaries that interface with other cells in muscles and organs. The veins collect blood from the capillaries and carry it back to the heart.

Blood pressure is measured in a major artery in your upper arm at about the same height as your heart. When air is pumped into the cuff around your upper arm, it compresses this artery, so that the blood flow stops. The nurse places the stethoscope, a listening device, near this artery at a lower point in the arm and listens for the blood flow to restart as the air in the cuff is released.

The heart is a pulsating pump that pumps blood most strongly when the heart muscle is most fully compressed. The pressure therefore fluctuates between high and low values. The higher reading in the blood pressure measurement, the *systolic*

pressure, is taken when the blood just begins to spurt through the compressed artery at the peak of the heart's cycle. The lower reading, the *diastolic* pressure, is taken when blood flow occurs even at the low point in the cycle. There are distinctive sounds picked up by the stethoscope at these two points.

The pressure recorded is actually the pressure in the air cuff for these two conditions. It is a *gauge* pressure, meaning that it is the pressure difference between the pressure being measured and atmospheric pressure. It is recorded in the unit mm of mercury, which is the common way of recording atmospheric pressure. Thus, a reading of 125 means that the pressure in the cuff is 125 mm of mercury *above* atmospheric pressure. A mercury manometer that is open to the air on one side (see the drawing) will measure gauge pressure directly.



An open-ended manometer can be used to measure the gauge pressure of the cuff. The stethoscope is used to listen for sounds indicating the re-start of blood flow.

High blood pressure can be a symptom of many health problems, but most specifically, it is a warning sign for heart attacks and strokes. When arteries become constricted from the buildup of plaque deposits inside, the heart must work harder to pump blood through the body. Over time, this can weaken the heart muscle. The other danger is that blood vessels might burst in the brain, causing a stroke, or blood clots might break loose and block smaller arteries in the heart or brain. In any case, high blood pressure is an important indicator of a potential problem.

Low blood pressure can also be a sign of problems. It can cause dizziness when not enough blood is reaching the brain. When you stand up quickly, you sometimes experience a feeling of light-headedness, because it takes a brief time for the heart to adjust to the new condition where your head is higher. Giraffes have a blood pressure about three times higher than that of humans (in gauge pressure terms). Why do you suppose this is so?



**Figure 9.8** Two teams of eight horses were unable to separate the hemispheres of von Guericke's evacuated metal sphere. What force pushes the two hemispheres together?  
Colorization by: Robin Treadwell/Science Source

He then pumped the air out of the sphere formed from the two hemispheres, using a crude vacuum pump he had invented. As shown in figure 9.8, two eight-horse teams were unable to pull the hemispheres apart. When the stopcock was opened to let air back into the evacuated sphere, the two hemispheres could easily be separated.

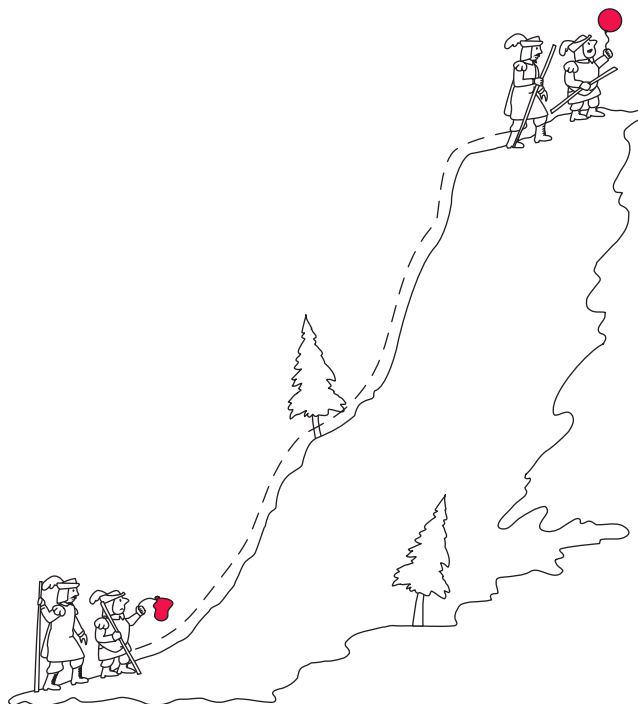
### Variations in atmospheric pressure

If we live at the bottom of a sea of air, we might expect pressure to decrease as we go up in altitude. The pressure we experience results from the weight of the air above us. As we go up from the Earth's surface, there is less atmosphere above us, so the pressure should decrease.

Similar reasoning led Blaise Pascal to try to measure atmospheric pressure at different altitudes shortly after Torricelli's invention of the mercury barometer. Because Pascal was in poor health through most of his adult life, and not up to climbing mountains, in September of 1648 he sent his brother-in-law to the top of the Puy-de-Dome mountain in central France with a barometer similar to Torricelli's. Pascal's brother-in-law found that the height of the mercury column supported by the atmosphere was about 7 cm lower at the top of the 1460-m (4800-ft) mountain than at the bottom.

Pascal also had his brother-in-law take a partially inflated balloon to the top of the mountain. As Pascal predicted, the balloon expanded as the climbers gained elevation, indicating a decrease in the external atmospheric pressure (fig. 9.9). Pascal was even able to show a decrease in pressure within the city of Clermont between the low point in town and the top of the cathedral tower. The decrease was small but measurable.

Using the newly invented barometer, Pascal also observed variations in pressure related to changes in the weather. For example, column heights were lower on stormy days than on clear days, and falling atmospheric pressure pointed to stormy weather ahead. These pressure variations have been



**Figure 9.9** A balloon that was partially inflated near sea level expanded as the experimenters climbed the mountain.

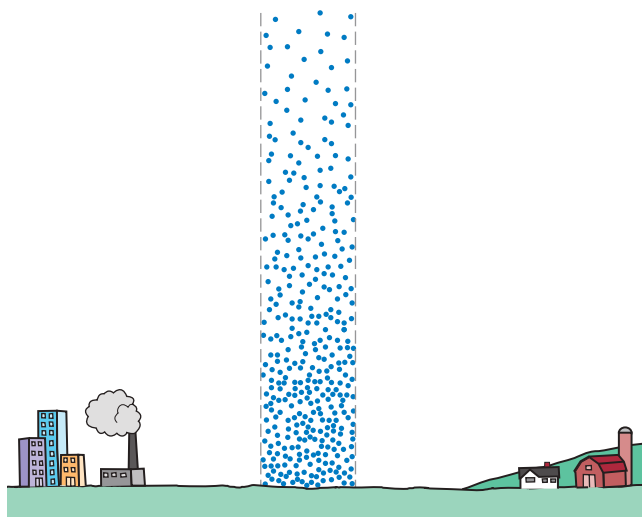
used ever since to indicate changes in weather. Readings are usually corrected to sea level, however, so that variations in altitude do not mask changes related to weather.

### The weight of a column of air

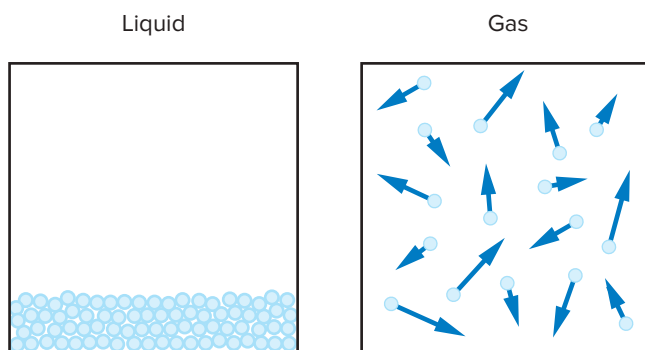
Can we calculate the variation in atmospheric pressure with altitude the same way we compute the pressure at the bottom of a column of mercury? We would need to know the weight of the column of air above us. Even though mercury and air are both fluids, there is a significant difference (besides the difference in density) between the behavior of a column of mercury and a column of air.

Mercury, like most liquids, is not readily compressible. In other words, increasing the pressure on a given amount of mercury does not change the volume of the mercury much. The density of the mercury (mass per unit volume) is the same near the bottom of the column of mercury as near the top. A gas such as air, on the other hand, is easy to compress. As the pressure changes, the volume changes, and so does the density. Therefore, we cannot use a single value for the density to compute the weight of a column of air. Its density decreases as we rise in the atmosphere (fig. 9.10).

This major difference between gases and liquids comes from differences in their atomic or molecular "packing." Except at very high pressures, the atoms or molecules of a gas are separated by large distances compared to the size of the atoms themselves, as in figure 9.11. The atoms in a liquid, on the other hand, are closely packed, much like those in a solid. They cannot be easily squeezed.



**Figure 9.10** The density of a column of air decreases as altitude increases because air expands as pressure decreases.



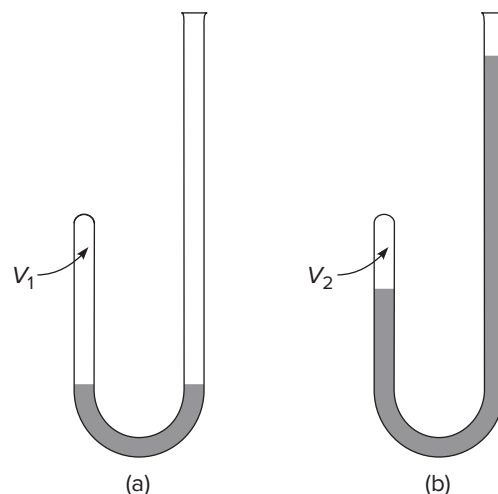
**Figure 9.11** The atoms in a liquid are closely packed, while those in a gas are separated by much larger distances.

Gases are springy. They can readily be compressed to a small fraction of their initial volume. They can also expand if pressure is reduced, like the gas in Pascal's balloon. Changes in temperature are likely to affect the volume or pressure of a gas much more than they affect a liquid. If the temperature is held constant, however, the volume changes with changes in pressure.

### How does the volume of a gas change with pressure?

Variations in the volume and density of a gas that accompany changes in pressure were studied by Robert Boyle (1627–1691) in England, as well as by Edme Mariotte (1620–1684) in France. Boyle's results were first reported in 1660 but went unnoticed on the European continent, where Mariotte published his similar conclusions in 1676. Both were interested in the springiness, or compressibility, of air.

Both experimenters used a bent glass tube sealed on one end and open on the other (fig. 9.12). In Boyle's experiment, the tube was partially filled with mercury, so that air was



**Figure 9.12** In Boyle's experiment, adding mercury to the open side of the bent tube caused a decrease in the volume of the trapped air in the closed side.

trapped in the closed portion of the tube. He allowed air to pass back and forth initially, so the pressure in the closed side of the tube was equal to atmospheric pressure and the column of mercury on either side was at the same height.

As Boyle added mercury to the open end of the tube, the volume of the air trapped on the closed side decreased. When he added enough mercury to increase the pressure to twice atmospheric pressure, the height of the air column on the closed side decreased by one-half. In other words, doubling the pressure caused the volume of air to decrease by half. Boyle discovered that the volume of a gas is inversely proportional to the pressure.

We can express **Boyle's law** in symbols:

$$PV = \text{constant}$$

where  $P$  is the pressure in the gas and  $V$  is the volume of the gas. If the pressure increases, the volume decreases in inverse proportion to keep the product of pressure and volume constant. We often write Boyle's law (also known as Mariotte's law in continental Europe) as

$$P_1V_1 = P_2V_2$$

where  $P_1$  and  $V_1$  are the initial pressure and volume, and  $P_2$  and  $V_2$  are the final pressure and volume (see example box 9.2). For Boyle's law to be valid, a fixed mass or quantity of gas must be kept at a constant temperature while the pressure and volume change.

As we gain altitude, atmospheric pressure decreases, and the volume of a given mass of air increases. Because density is the ratio of the mass to the volume, the density of the air must be decreasing as the volume increases. In computing the weight of a column of air, we have to take the change in density into account, and the computation becomes more complex than for the column of mercury. The density of a gas also depends on temperature, which usually decreases as we gain altitude, a further complication.

## Example Box 9.2

### Sample Exercise: How Does the Volume of a Gas Change with Pressure?

You may have noticed that bubbles rising in a liquid increase in size. A scuba diver releases bubbles of air that increase in volume as they rise through the water. At 40 m, the maximum depth for an experienced diver, the pressure is approximately 4.9 atm. If a scuba diver exhales a bubble at a depth of 40 m with a volume of approximately 2.5 cm<sup>3</sup>, what will the volume of the bubble be at the surface, where the pressure is 1.0 atm? Assume the water temperature does not change with depth.

$$\begin{aligned}
 P_1 &= 4.9 \text{ atm} & P_1 V_1 &= P_2 V_2 = \text{constant} \\
 P_2 &= 1 \text{ atm} & V_2 &= \left(\frac{P_1}{P_2}\right) V_1 \\
 V_1 &= 2.5 \text{ cm}^3 & & \\
 V_2 &=? & & \\
 & & V_2 &= \left(\frac{4.9 \text{ atm}}{1 \text{ atm}}\right) 2.5 \text{ cm}^3 \\
 & & V_2 &= \mathbf{12.25 \text{ cm}^3}
 \end{aligned}$$

We live at the bottom of a sea of air, whose pressure we can measure with barometers. The earliest barometers were a column of mercury in a closed glass tube. The height of the column supported by atmospheric pressure is a measure of the pressure. Atmospheric pressure decreases with increasing altitude, because it is determined by the weight of the column of air above. Determining the weight of a column of air is harder than determining the weight of a column of mercury, however, because air is compressible, and its density varies with altitude. Boyle's law describes how the volume of a gas changes with pressure: Increasing the pressure decreases the volume in inverse proportion.

## 9.3 Archimedes' Principle

Why do some things float, while others do not? Is floating determined by the weight of the object? A large ocean liner floats, but a small pebble quickly sinks. Clearly, it is not a matter of the total weight of the object. The density of the object is the key. Objects that are denser than the fluid they are immersed in will sink—those less dense will float. The complete answer to the question of why things sink or float is found in Archimedes' principle, which describes the *buoyant force* exerted on any object fully or partly immersed in a fluid.

### What is Archimedes' principle?

A block of wood floats, but a metal block of the same shape and size sinks. The metal block weighs more than the block of wood, even though it is the same size, which means that the metal is denser than wood. Density is the ratio of the mass to the volume (or mass per unit volume). The metal has a greater mass than wood for the same volume. Because weight is found by multiplying the mass by the gravitational acceleration  $g$ , the metal also has a greater weight for the same volume.

If we compared the densities of the metal and wood blocks to that of water, we would find that the metal block has a density greater than water's and that the density of the wood block is less than water's. The *average* density of an object compared to a fluid is what determines whether the object will sink or float in that fluid.

If we push down on a block of wood floating in a pool of water, we can clearly feel the water pushing back up on the block. In fact, it is hard to submerge a large block of wood or a rubber inner tube filled with air. They keep popping back up to the surface. The upward force that pushes such objects back toward the surface is called the **buoyant force**. If the block of wood is partially submerged at first and you push down to submerge it farther, the buoyant force gets larger as more of the block is under water.

Legend has it that Archimedes was sitting in the public baths observing floating objects when he realized what determines the strength of the buoyant force. When an object is submerged, its volume takes up space occupied by water: It *displaces* the water, in other words. The more water displaced by the object as you push downward, the greater the upward buoyant force. **Archimedes' principle** can be stated as follows:

The buoyant force acting on an object fully or partially submerged in a fluid is equal to the weight of the fluid displaced by the object.

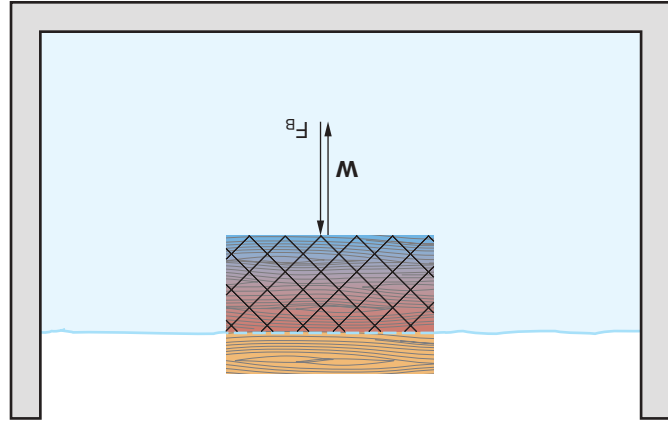
In the case of a wooden block floating on the surface of the water, only a portion of its volume will be submerged, as shown in figure 9.13. This portion displaces enough water to create a buoyant force, described by Archimedes' principle, equal to the weight of the block.

### What is the source of the buoyant force?

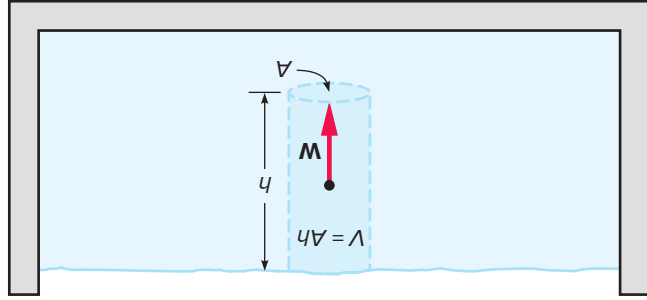
The source of the buoyant force described by Archimedes' principle is the increase in pressure that occurs with increasing depth in a fluid. When we swim to the bottom of the deep end of a swimming pool, we can feel pressure building on our ears. The pressure near the bottom of the pool is larger than near the surface for the same reason that the pressure of the atmosphere is greater near the surface of the Earth than at higher altitudes. The weight of the fluid above us contributes to the pressure we experience.

A large can filled with water demonstrates this variation of pressure with depth. If we punch holes in the can at different depths, the water shoots from a hole near the bottom of the can with a much greater horizontal velocity than from a hole punched near the top (fig. 9.15). Because the can is submerged in the atmosphere, the excess pressure above atmospheric pressure is most significant. A larger excess pressure provides a larger accelerating force for the emerging water.

How does the fact that pressure increases with depth explain the buoyant force? Imagine a rectangular-shaped object, such as a steel block, submerged in water. If we suspend the block from a string, as in figure 9.16, the



**Figure 9.13** The volume of the water displaced by the floating wood block is represented by the cross-hatched portion of the block. The buoyant force acting on the block is equal to the weight of this displaced water.



**Figure 9.14** The weight of a column of water is proportional to the volume of the column. The volume  $V$  is equal to the area  $A$  times the height  $h$ .

By Pascal's principle, the atmospheric pressure pushing on the surface of the pool extends uniformly throughout the fluid. To get the total pressure at some depth, we add the excess pressure resulting from the weight of the water to the atmospheric pressure. For many purposes, the excess pressure above atmospheric pressure is of most interest. Because our bodies have internal pressures equal to atmospheric pressure, our eardrums are sensitive to the increase in pressure *beyond* atmospheric pressure rather than to the total pressure.

To find the excess pressure at a certain depth in a liquid, we need to determine the weight of the liquid above that depth. The problem is similar to finding the pressure at the bottom of a column of mercury, discussed in section 9.2. If we imagine a column of water in a swimming pool (fig. 9.14), the weight of the column depends on the volume of the column and the density of the water. The volume of the column is directly proportional to its height  $h$ , and therefore so is its weight. The excess pressure increases in direct proportion to the depth  $h$  below the surface.\*

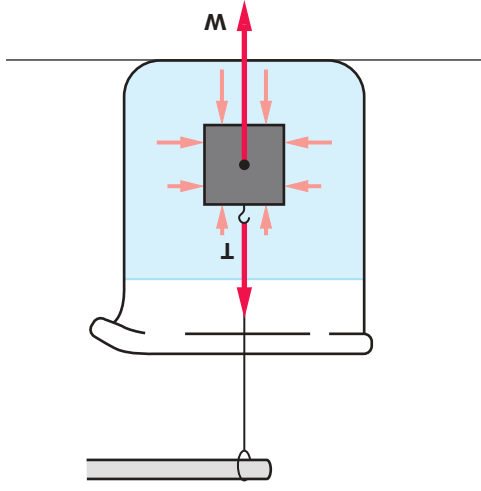
\*Since the weight  $W = mg = V\rho g$ , and  $V = Ah$ , the excess pressure,  $\Delta P = \frac{W}{A} = \frac{\rho g Ah}{A} = \rho gh$ . The symbol for density,  $\rho$ , is the Greek letter rho.

**Figure 9.15** Water emerging from a hole near the bottom of a can filled with water has a larger horizontal velocity than water emerging from a hole near the top.

Jill Braten/McGraw-Hill Education



**Figure 9.16** The pressure acting on the bottom of the suspended metal block is greater than that acting on the top due to the increase of pressure with depth.





pressure of the water will push on the block from all sides. Because the pressure increases with depth, however, the pressure at the bottom of the block is greater than that at the top. This greater pressure produces a larger force ( $F = PA$ ) pushing up on the bottom of the block than that pushing down on the top. The difference in these two forces is the buoyant force. The buoyant force is proportional to both the height and the cross-sectional area of the block, and thus to its volume,  $Ah$ . The volume of the fluid displaced by the object is directly related to the weight of the fluid displaced, which leads to the statement of Archimedes' principle.

### What forces act on a floating object?

If there are no strings attached, or other forces pushing or pulling on an object partially or fully submerged in a fluid, only the weight of the object and the buoyant force determine what happens. The weight is proportional to the density and volume of the object, and the buoyant force depends on the density of the fluid and the volume of fluid displaced by the object. The motion of the object is governed by the sizes of the buoyant force pushing upward and the weight pulling downward. There are just three possibilities:

1. **The density of the object is greater than the density of the fluid.** If the object has an average density greater than the fluid it is submerged in, the weight of the object will be greater than the weight of the fluid displaced by the fully submerged object, because the same volume is involved. Because the weight, which acts downward, is greater than the buoyant force, which acts upward, the net force acting on the object will be downward and the object will sink (unless it is supported by another force, such as one exerted by a string tied to the block).
2. **The density of the object is less than the density of the fluid.** If the object's density is less than the fluid's, the buoyant force will be larger than the weight of the object when the object is fully submerged. The net force acting on the object will be upward, and the object will float to the top. When it reaches the surface of the fluid, just enough of the object remains submerged so that the weight of the fluid displaced by the submerged portion of the object (the buoyant force) will equal the weight of the object. The net force is zero, and the object is in equilibrium. It has no acceleration.
3. **The density of the object equals the density of the fluid.** The weight of the object then equals the weight of the fluid displaced when the object is submerged. The object floats when fully submerged, rising or sinking in the fluid by changing its average density slightly, which is what a fish or a submarine does. The average density of a submarine can be increased or decreased by taking in or releasing water.

### Why does a boat made of steel float?

Steel is a lot denser than water, and a large steel boat is a very heavy object. Why does it float? The answer is that the boat is not made of solid steel all the way through. There are open spaces filled with air and other materials in the boat. A solid piece of steel will quickly sink, but if the *average* density of the boat is less than that of the water it is displacing, a steel boat will certainly float. Because of the air spaces and other materials, the average density of the boat will be much less than that of steel.

According to Archimedes' principle, the buoyant force that acts on the boat must equal the weight of the water displaced by the hull of the boat. For the boat to be in equilibrium (with a net force of zero), the buoyant force must equal the weight of the boat (see example box 9.3). As we load the boat with cargo, the total weight of the boat increases. So must the buoyant force. The amount of water displaced by the hull must increase, so the boat sinks lower in the water. There is a limit to how much weight can be added to a boat (often expressed as tons of displacement). A fully loaded oil tanker will ride much lower in the water than an unloaded tanker (fig. 9.17).

Other important considerations in designing a boat are the shape of the hull and how the boat will be loaded. If the boat's center of gravity is too high or if the boat is unevenly loaded, there is some danger that the boat will tip over. Wave action and winds add to this danger, so a margin of safety must be included in the design. Once water enters the boat, the overall weight of the boat and its average density increase. When the boat's average density becomes larger than the average density of water, down it goes.

## Example Box 9.3

### Sample Exercise: Floating Objects

A certain boat is floating on the water and displaces  $4.0 \text{ m}^3$  of water. The density of water is  $1000 \text{ kg/m}^3$ .

- a. What is the mass of the water displaced by the boat?
- b. What is the weight of the water displaced by the boat?
- c. What is the buoyant force acting upward on the boat?
- d. What is the weight of the boat?

$$\begin{aligned} \text{a. } V &= 4.0 \text{ m}^3 & \rho &= m/V \\ \rho &= 1000 \text{ kg/m}^3 & m &= \rho V \\ m &=? & m &= (1000 \text{ kg/m}^3)(4.0 \text{ m}^3) \\ & & m &= \mathbf{4000 \text{ kg}} \end{aligned}$$

$$\begin{aligned} \text{b. } m &= 4000 \text{ kg} & W &= mg \\ g &= 9.8 \text{ m/s}^2 & W &= (4000 \text{ kg})(9.8 \text{ m/s}^2) \\ & & W &= \mathbf{39,200 \text{ N}} \end{aligned}$$

- c. Buoyant force = weight of fluid displaced =  $39,200 \text{ N}$ .
- d. If the object is floating, the buoyant force is equal to the weight of the object. Weight of boat =  $39,200 \text{ N}$ .



**Figure 9.17** A fully loaded tanker rides much lower in the water than an empty tanker.  
Chris Wilkins/AFP/Getty Images

### When will a balloon float?

Buoyant forces also act on objects submerged in a gas, such as air. If a balloon is filled with a gas whose density is less than the density of air, the average density of the balloon is less than that of air, and the balloon will rise. Helium and hydrogen are the two common gases with densities less than that of air, but helium is more commonly used in balloons, even though its density is somewhat greater than the density of hydrogen. Hydrogen can combine explosively with the oxygen in air, making its use dangerous.

The average density of the balloon is determined by the material the balloon is made of as well as by the density of the gas with which it is filled. Ideal materials for making balloons stretch very thin without losing strength. They should also remain impermeable to the flow of gas, so that the helium or other gas will not be lost rapidly through the skin of the balloon. Balloons made of Mylar (which is often coated with aluminum) are much less permeable than ordinary latex balloons.

Hot-air balloons take advantage of the fact that any gas will expand when it is heated. If the volume of the gas increases, its density decreases. As long as the air inside the balloon is much hotter than the air surrounding the balloon, there will be an upward buoyant force. The beauty of a hot-air balloon is that we can readily adjust the density of the air within the balloon by turning the gas-powered heater on or off. This gives us some control over whether the balloon will ascend or descend.

Buoyant forces and Archimedes' principle are useful in applications besides boats and balloons. We can use Archimedes' principle to determine the density of objects or the fluid in which they are submerged. This, in fact, was Archimedes' original application. Archimedes is said to have used his idea to determine the density of the king's crown to ascertain whether it was truly pure gold. (The king suspected a goldsmith of fraud.) Gold is denser than cheaper metals that might have been substituted for gold.

Archimedes' principle states that the buoyant force acting on an object is equal to the weight of the fluid displaced by the object. If the average density of the object is greater than the density of the fluid being displaced, the weight of the object will exceed the buoyant force and the object will sink. The buoyant force results because the pressure on the bottom of the object is greater than that on the top, because pressure increases with depth. Archimedes' principle can be used to understand the behavior of boats, balloons, and objects floating in a bathtub or stream.

## 9.4 Fluids in Motion

If we return to the bank of the stream mentioned in the introduction to this chapter, what else can we see? When a stick or toy boat floats down the stream, we might notice that the speed of the current varies from point to point in the stream. Where the stream is wide, the flow is slow. Where the stream narrows, the speed increases. Also, the speed is usually greater near the middle of the stream than close to the banks. Eddies and other features of turbulent flow may be observed.

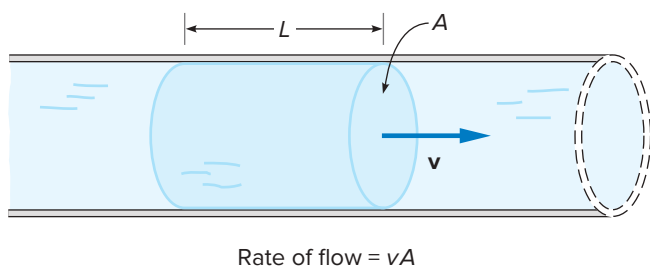
These are all characteristics of the flow of fluids. The speed of flow is affected by the width of the stream and by the *viscosity* of the fluid, a measure of the frictional effects within the fluid. Some of these features are easy to understand, while others, particularly the behavior of turbulent flow, are still areas of active research.

### Why does the water speed change?

One of the most obvious features of a stream's current is that the water speed increases where the stream narrows. Our stick or toy boat moves slowly through the wider portions of the stream but gains speed when it passes through a narrow spot or rapids.

As long as no tributaries add water to the stream and there are no significant losses through evaporation or seepage, the flow of the stream is continuous. In a given time, the same amount of water that enters the stream at some upper point leaves the stream at some lower point. We call this *continuity of flow*. If flow were not continuous, water would collect at some point or, perhaps, be lost somewhere within that segment of the stream, something that does not usually happen.

How would we describe the *rate* of flow of water through a stream or pipe? A volume flow rate is a volume divided by time—gallons per minute, or in the metric system, liters per second or cubic meters per second. As figure 9.18 shows, the volume of a portion of water of length  $L$  flowing past some point in a pipe is the product of



**Figure 9.18** The rate at which water moves through a pipe is defined by the volume divided by time. This is equal to the speed of the water times the cross-sectional area.

the length times the cross-sectional area  $A$ , or  $LA$ . The speed with which this volume moves determines the rate of flow.

What is the rate of flow through the pipe? To find the rate, we divide the water's volume  $LA$  by the time interval  $t$ , which gives us  $LA/t$ . Because  $L/t$  is the speed  $v$  of the water, we get

$$\text{Rate of flow} = vA$$

This expression is valid for any fluid and makes intuitive sense: The greater the speed, the greater the rate of flow, and the larger the cross section of the pipe or stream, the greater the rate of flow.

How does the rate of flow explain changes in the speed of the water? If the flow through the pipe is continuous, the rate of flow must be the same at any point along the pipe. The same number of gallons per minute flow past each point. If the cross-sectional area  $A$  decreases, the speed  $v$  increases to keep the rate  $vA$  constant. If the cross-sectional area increases, the speed decreases to maintain the same rate of flow (see example box 9.4).

## Example Box 9.4

### Sample Exercise: Velocity Changes in Moving Fluids

Look ahead at the circular pipe shown in figure 9.24. Assume it has a radius of 6 cm in the wide part and 4.5 cm in the narrow part. If the fluid is initially flowing at a rate of 2 m/s in the wide part, what is the velocity in the narrow part?

$$\begin{aligned} r_1 &= 6.0 \text{ cm} & A &= \pi r^2 \\ r_2 &= 4.5 \text{ cm} & A_1 &= \pi(6.0 \text{ cm})^2 = 113.1 \text{ cm}^2 \\ & & A_2 &= \pi(4.5 \text{ cm})^2 = 63.6 \text{ cm}^2 \\ v_1 &= 2 \text{ m/s} & A_1 v_1 &= A_2 v_2 \\ v_2 &= ? & v_2 &= (A_1/A_2)v_1 \\ & & v_2 &= (113.1 \text{ cm}^2/63.6 \text{ cm}^2)(2 \text{ m/s}) \\ & & &= \mathbf{3.56 \text{ m/s}} \end{aligned}$$

Note that in the narrow part of the pipe, the velocity increases.

The same principle applies to a stream. Where the stream is narrower, the cross-sectional area of the stream will generally be smaller than at a wider point in the stream. The stream may be deeper at the narrow places, but usually not enough to make the cross-sectional area as large as at the wider places. If the cross-sectional area decreases, the fluid speed must increase to maintain the rate of flow.

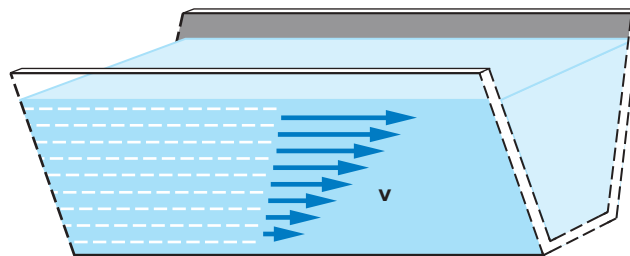
### How does viscosity affect the flow?

Up to this point, we have ignored any variation in the fluid speed across its cross-sectional area. We mentioned that the water speed will usually be greatest near the middle of the stream. The reason is the frictional or viscous effects between layers of the fluid itself and between the fluid and the walls of the pipe or the banks of the stream.

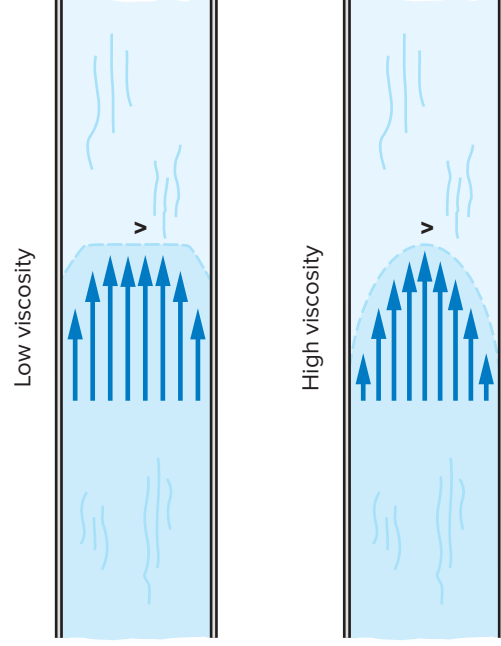
Imagine the fluid as made up of layers, and you can see why the speed will be greatest near the center. Figure 9.19 shows different layers of a fluid moving through a trough. Because the bottom of the trough is not moving, it exerts a frictional force on the bottom layer of fluid, which moves more slowly than the layer immediately above it. This layer exerts a frictional drag, in turn, on the layer above it, which flows more slowly than the next one above it, and so on.

The **viscosity** of the fluid is the property of fluid that determines the strength of the frictional forces between the layers of the fluid—the larger the viscosity, the larger the frictional force. The magnitude of the frictional force also depends on the area of contact between layers and the rate at which the speed is changing across the layers. If these other factors are the same, a fluid with a high viscosity, such as molasses, experiences a larger frictional force between layers than a fluid with a low viscosity, such as water.

A thin layer of fluid that does not move at all is usually found next to the walls of the pipe or trough. The fluid speed increases as the distance from the wall increases. The exact variation with distance depends on the viscosity of the fluid and the overall rate of flow of the fluid through the pipe. For a fluid with a low viscosity, the transition to the maximum



**Figure 9.19** Because of the frictional or viscous forces between layers, each layer of fluid flowing in the trough moves more slowly than the layer immediately above.



**Figure 9.20** The velocity increases rapidly from the wall inward for a low-viscosity fluid but more gradually for a high-viscosity fluid.

speed occurs over a short distance from the wall. For a fluid with a high viscosity, the transition takes place over a larger distance, and the speed may vary throughout the pipe or trough (fig. 9.20).

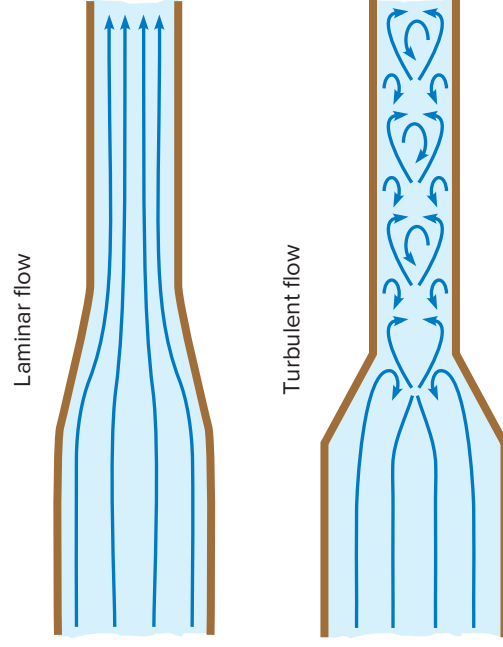
The viscosity of different fluids varies enormously. Honey, thick oils, and syrup all have much higher viscosities than water or alcohol. Most liquids have much higher viscosities than gases. The viscosity of a given fluid also changes substantially if its temperature changes. An increase in temperature usually produces a decrease in viscosity. Heating a bottle of syrup, for example, makes it less viscous, causing it to flow more readily.

### Laminar and turbulent flow

One of the most fascinating questions about the flow of fluids is why the flow is smooth, or *laminar*, under some conditions but *turbulent* in others. Both kinds of flow can be observed in rivers and creeks. How do they differ—and what determines which type of flow prevails?

In sections of a stream where flow is smooth, or laminar, there are no eddies or other similar disturbances. The flow of the stream can be described by *streamlines* that indicate the direction of flow at any point. The streamlines for laminar flow are roughly parallel, as in figure 9.21. The speeds of different layers may vary, but one layer moves smoothly past another.

As the stream narrows and the fluid speed increases, the simple laminar-flow pattern disappears. Ropelike twists in the streamlines appear, then whorls and eddies: The flow becomes *turbulent*. In most applications, **turbulent flow** is undesirable, because it greatly increases the fluid's resistance to flow through a pipe or past other surfaces. It *does* make river rafting much more exciting, though.



**Figure 9.21** In laminar flow, the streamlines are roughly parallel to one another. In turbulent flow, the flow patterns are much more complicated.

If the density of a fluid and the width of the pipe or stream do not vary, the transition from laminar to turbulent flow is predicted by two quantities, the average fluid speed and the viscosity. Higher speeds are more likely to produce turbulent flow, as we would expect. On the other hand, higher viscosities inhibit turbulent flow. Larger fluid densities and pipe widths are also more conducive to turbulent flow. From experiments, scientists have been able to use these quantities to predict with some accuracy the speed at which the transition to turbulent flow will begin.

You can observe the transition from laminar to turbulent flow in many common phenomena. The higher water speeds at the narrowing of a stream often produce turbulent flow. The transition can also be seen in the flow of water from a spigot. A small flow rate will usually produce laminar flow, but as the flow rate increases, the flow becomes turbulent. Flow may be smooth near the top of the water column but turbulent lower down, as the water is accelerated by gravity. Try it next time you are near a sink.

You can also see this phenomenon in the smoke rising from a candle or incense stick. Near the source, the upward flow of the smoke is usually laminar. As the smoke accelerates upward (due to the buoyant force), the column widens, and the flow becomes turbulent (fig. 9.22). The whorls and eddies are much like those you see in a stream.

The conditions that produce turbulence are well understood, but until recently, scientists could not explain why the flow patterns develop as they do. Some surprising patterns can be discerned in the seemingly chaotic behavior of turbulent flow in various situations. Recent theoretical advances in the study of chaos have produced a much better understanding of the reasons for these patterns.



**Figure 9.22** Smoke rising from an incense stick first exhibits laminar flow, and then, as the speed increases and the column rises, turbulent flow appears.  
windcoast/Shutterstock

The study of chaos and the regular behaviors that appear in turbulent flow have provided new insights into global weather patterns, including hurricanes and other phenomena. Perhaps the most striking examples of atmospheric flow patterns are the photographs sent back from the *Voyager* flyby of the planet Jupiter. Whorls and eddies can be seen in the flow of the atmospheric gases on Jupiter. These include the famous red spot, which is now thought to be a giant, and very stable, atmospheric eddy (fig. 9.23).



**Figure 9.23** Whorls and eddies, including the giant red spot (lower left), can be seen in the atmosphere of the planet Jupiter.  
Source: NASA-JPL

The rate of flow of a stream is equal to the fluid speed multiplied by the cross-sectional area through which the stream is flowing. For the flow to be continuous, the speed must increase where the stream narrows to pass through a smaller cross-sectional area. The fluid speed of the stream also varies across its area because of viscosity: The fluid speed is largest at the center and smallest near the banks or pipe walls. Smooth, or laminar, flow gives way to turbulent flow with its eddies and whorls as the fluid speed increases or the viscosity decreases.

## 9.5 Bernoulli's Principle

Have you ever wondered why a spinning ball curves? This and many other interesting phenomena can be explained by a principle regarding the flow of fluids that was published in 1738 by Daniel Bernoulli (1700–1782) in a treatise on hydrodynamics. Although energy ideas had not been fully developed at that time, Bernoulli's principle is really a result of conservation of energy.

### What is Bernoulli's principle?

What happens if we do work on a fluid, increasing its energy? This increase may show up as an increase in kinetic energy of the fluid, leading to an increase in the fluid's speed. It may also appear as an increase in potential energy if the fluid is squeezed (elastic potential energy) or if the fluid is raised in height (gravitational potential energy). Bernoulli considered all of these possibilities. Bernoulli's principle is a direct result of applying conservation of energy to the flow of fluids.

The most interesting examples of Bernoulli's principle involve changes in kinetic energy. If a fluid that is not compressible (not squeezable) is flowing in a level pipe or stream, any work done on this fluid will increase its kinetic energy. (If a fluid is compressible, some of the work is used to squeeze the fluid.) To accelerate the fluid and increase its kinetic energy, there must be a net force doing work on the fluid. This force is associated with a difference in pressure from one point to another within the fluid.

If there is a difference in pressure, the fluid accelerates from the region of higher pressure toward the region of lower pressure, because that is the direction of the force acting on the fluid. We expect to find higher fluid speeds in the regions of lower pressure. In the simple case of an incompressible fluid flowing in a level pipe or stream,\* work and

\*If the stream is not level, an additional term,  $\rho gh$ , must be included to account for changes in potential energy.

energy considerations lead to a statement of **Bernoulli's principle**:

The sum of the pressure plus the kinetic energy per unit volume of a flowing fluid must remain constant.

$$P + \frac{1}{2}\rho v^2 = \text{constant}$$

Here,  $P$  is the pressure,  $\rho$  is the density of the fluid, and  $v$  is the fluid's speed. The second term in this sum is the kinetic energy per unit volume (kinetic energy divided by volume) of the fluid, because density is mass divided by volume.

A fuller statement of Bernoulli's principle would include the effects of gravitational potential energy, allowing for changes in the height of the fluid. However, many of the most interesting effects can be investigated using the form just stated. In applying Bernoulli's principle, the association of lower pressures with higher fluid speeds is often the key point.

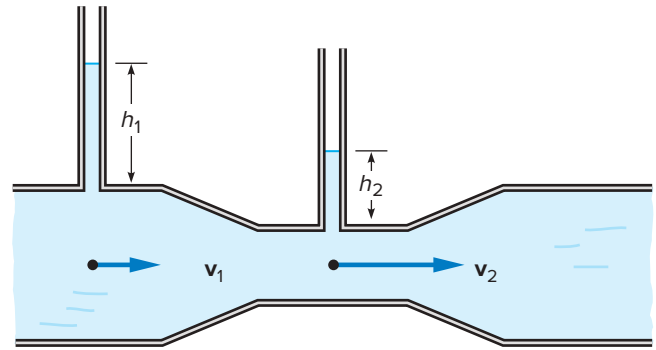
### How does the pressure vary in pipes and hoses?

Consider a pipe with a constriction in its center section, as in figure 9.24. Would you expect the pressure of water flowing in the pipe to be greatest at the constriction or in the wider sections of the pipe? Intuition leads you to suspect that the pressure is greater in the constricted section, but this is *not* the case.

We know the speed of the water will be greater in the constricted section (where the cross-sectional area is smaller) than in the wider portions of the pipe because of the concept of continuous flow. What does Bernoulli's principle tell us? To keep the sum  $P + \frac{1}{2}\rho v^2$  constant, the pressure must be larger where the fluid speed is smaller. In other words, if the speed increases, the pressure must decrease.

Open tubes at different places in the pipe (fig. 9.24) can serve as simple pressure gauges. For the water in these open tubes to rise, fluid pressure must be greater than atmospheric pressure. The height that the fluid rises will depend on how much greater its pressure is. The water level in these tubes will reach a greater height above the main pipe where the pipe is wider rather than at the constriction, indicating that the pressure is higher in the wider portion of the pipe.

This result goes against our intuition, because we tend, incorrectly, to associate higher pressure with higher speed. Another confirming example is the nozzle on a hose. The nozzle constricts the area of flow and increases the fluid's speed. By Bernoulli's principle, the pressure of the water is



**Figure 9.24** Vertical open pipes can serve as pressure gauges. The height of the column of water is proportional to the pressure. The pressure of a moving fluid is greater where the fluid velocity is smaller.

smaller at the narrow end of the nozzle than farther back in the hose, contrary to what we expect.

If you place your hand in front of the nozzle, you will feel a force on your hand as the water strikes it. This force results from the change in the velocity and momentum of the water as it strikes your hand. By Newton's second law, a force is required to produce this change in momentum, and by Newton's third law, the force exerted on the water by your hand is equal in magnitude to the force exerted on your hand by the water. That force is not directly associated with the fluid pressure in the hose—the pressure is actually greater farther back in the hose where the water is not moving very fast.

### Airflow and Bernoulli's principle

Bernoulli's principle, as we have stated it, is only valid for fluids whose density does not change (noncompressible fluids), but we often extend it to investigate effects of the motion of air and other compressible gases. Even for compressible fluids, a larger fluid speed is usually associated with a smaller fluid pressure.

A simple demonstration will make a believer of you. Take half a sheet of tablet paper (or even a facial tissue) and hold it in front of your mouth, as in figure 9.25. The paper should hang down limply in front of your chin. If you blow across the top of it, the paper rises, and if you blow hard enough, the paper may even stand straight out horizontally. What is happening?

Blowing across the top of the paper makes the air flow across the top with a greater speed than underneath the paper. The air underneath presumably is not moving much at all. This greater speed leads to a reduction in pressure. Because the air pressure is then greater on the bottom of the paper than on the top, the upward force on the bottom of the paper is larger than the downward force on the top, so the paper rises. Contrary to intuition,



**Figure 9.25** Blowing across the top of a limp piece of paper causes the paper to rise, demonstrating Bernoulli's principle.  
Jill Braaten/McGraw-Hill Education

blowing between two strips of paper makes them move closer together rather than farther apart, for the same reason. Try it.

Bernoulli's principle is frequently used to explain the lift force on an airplane wing. The wing shape and tilt can produce a greater air speed across the top of the wing than across the bottom, leading to greater pressure on the bottom of the wing than on the top. Although the simplicity of this explanation can be appealing, it is also misleading and cannot yield accurate predictions. The effects involved in producing the lift forces on a wing are actually quite complex. They have been thoroughly explored and analyzed with the help of wind tunnels.

### What keeps the department-store ball in the air?

Another demonstration of Bernoulli's principle that uses airflow is often seen in department stores when vacuum cleaners are being advertised. A ball can be suspended in an upward-moving column of air produced by a vacuum cleaner. As the air moves upward, the speed of airflow is greatest in the center of the stream and falls off to zero away from the center. Once again, Bernoulli's principle requires that the pressure be smallest in the center, where the speed is greatest.

The pressure increases away from the center of the air column toward regions where the air is moving less rapidly.



**Figure 9.26** A ball is suspended in an upward-moving column of air produced by a hair dryer. The air pressure is smallest in the center of the column, where the air is moving with the greatest speed.

Jill Braaten/McGraw-Hill Education

If the ball moves out of the center of the air column, a larger pressure and a larger force act on the outer side of the ball than on the side nearer the center of the column. The ball moves back into the center. The upward force of air hitting the bottom of the ball holds it up, while the low pressure in the center of the column keeps the ball near the center. You can produce the same effect with a small ball and a hair dryer (fig. 9.26).

The motion of a curveball, discussed in everyday phenomenon box 9.2, provides another example of Bernoulli's principle at work. In all of these phenomena, we see the effects of a reduction in fluid pressure associated with an increase in fluid speed, as predicted by Bernoulli's principle. We do not always expect this. We are tempted to think that blowing between two pieces of paper will push them apart, for example, but a simple experiment shows otherwise. Understanding such surprises is part of the fun of physics.

Bernoulli's principle is derived from energy considerations and says that the sum of the pressure plus the kinetic energy per unit volume remains constant from one point in a fluid to another. This holds true if the fluid is not compressible and changes in height are not involved. Pressure, then, is lower where fluid speed is higher. This effect explains many surprising phenomena involving pipes, hoses, airplane wings, and the fact that blowing across the top of a piece of paper causes the paper to rise rather than drop.

## Everyday Phenomenon

## Box 9.2

### Throwing a Curveball

**The Situation.** Baseball players know that they can be badly fooled by a well-thrown curveball. The idea that a fast-moving curveball can be deflected by as much as a foot on its way to the plate is hard for some people to accept. Many people have insisted, over the years, that the curve is just an illusion. Does the path of a curveball really curve? If so, how can we explain it?



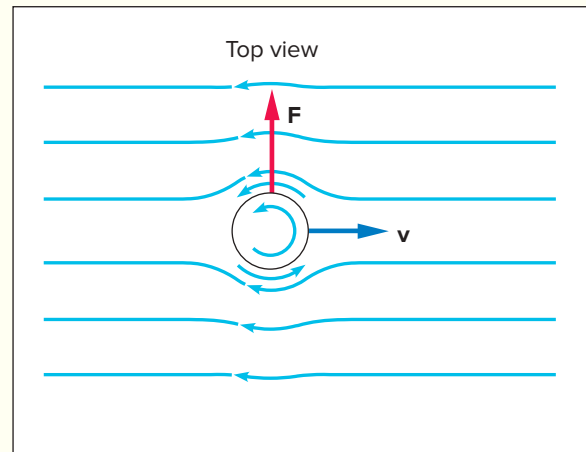
A batter is badly fooled by a curveball. Does the path of the ball really curve?

Mark Cunningham/Getty Images

**The Analysis.** There is no secret to throwing a curveball. A right-handed pitcher throws a curveball with a counterclockwise spin (as viewed from above), so that it curves away from a right-handed batter. The pitch is most effective when it starts out looking as if it is headed toward the inside of the plate and then curves over the plate and down and away from the batter.

Bernoulli's principle can explain the deflection of the ball's path. Because the surface of the spinning ball is rough, it drags a layer of air around with it, creating a whirlpool of air near the ball. The ball is also moving toward the plate, which produces an additional flow of air past the ball in the direction opposite the velocity of the ball. The whirlpool created by the spin of the ball causes the air to move more swiftly on the side opposite the right-handed batter, where the two effects add, than on the side nearer the batter, as shown in the drawing.

By Bernoulli's principle, a greater speed of airflow is associated with a lower pressure: The air pressure is lower on the side of the ball opposite the batter than on the near side. This difference in pressure produces a deflecting force on the ball, pushing it away from the right-handed batter.



The whirlpool of air created by the spin of the ball causes the air to move more rapidly on one side of the ball than on the other. This produces a deflecting force, as predicted by Bernoulli's principle.

Although Bernoulli's principle gives a good explanation of the direction of the deflecting force and the direction of the curve, it cannot be used to make accurate quantitative predictions. Air is a compressible fluid, and the usual form of Bernoulli's principle is valid only for noncompressible fluids, such as water. More accurate methods of treating the effects of airflow past the ball must be used for predicting the degree of curvature.

Both theoretical computations and experimental measurements have confirmed that there is a deflecting force on the ball and that the path of the ball does indeed curve. The degree of curvature depends on the rate of spin on the ball and the roughness of the surface of the ball, as you might expect from Bernoulli's principle. Some pitchers have been known to cheat by roughening the ball's surface with sandpaper hidden in their gloves. Debate continues about whether the orientation of the seams of the baseball also has an effect. The pitcher's grip on the ball is an important factor in how much spin he can put on the ball. Once the ball is released, however, experimental evidence suggests that the orientation of the seams is not important in the strength of the deflecting force.

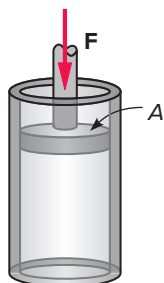
A good discussion of the theory and the experimental evidence is found in an article by Robert Watts and Ricardo Ferrer in the January 1987 issue of the *American Journal of Physics*, pages 40–44. The curved motion of spinning balls is important in other sports, too, such as golf and soccer. A good athlete needs to be able to recognize and take advantage of the effects of these curves.



## Summary

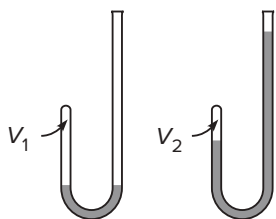
Fluid pressure is central to understanding the behavior of fluids, which include both liquids and gases. This chapter has focused on the effects of pressure in determining the behavior of both stationary fluids and fluids in motion.

**1 Pressure and Pascal's principle.** Pressure is defined as the ratio of force to area exerted on or by a fluid. According to Pascal's principle, pressure extends uniformly in all directions through a fluid, which explains the operation of hydraulic systems.



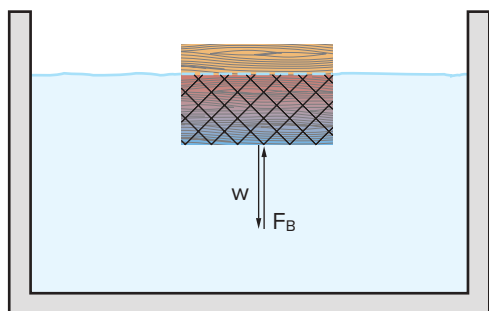
$$P = \frac{F}{A}$$

**2 Atmospheric pressure and the behavior of gases.** We can measure atmospheric pressure by determining the height of a column of mercury supported by the atmosphere. Atmospheric pressure decreases with increasing altitude. The density of air also changes with altitude, because a lower pressure leads to a larger volume, according to Boyle's law.

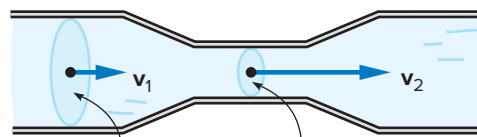


$$P_1 V_1 = P_2 V_2$$

**3 Archimedes' principle.** In a fluid, pressure increases with depth, producing a buoyant force on objects submerged in the fluid. Archimedes' principle states that this force is equal to the weight of the fluid displaced by the object. If the buoyant force is less than the weight of the object, it will sink in the fluid. Otherwise, it will float.



**4 Fluids in motion.** The rate of flow of a fluid is equal to the speed times the cross-sectional area,  $vA$ . In continuous flow, the speed increases if the area decreases. Fluids with high viscosity have a greater resistance to flow than those with low viscosity. As the flow speed increases, the flow may change from laminar (smooth) flow to turbulent flow.



$$v_1 A_1 = v_2 A_2$$

**5 Bernoulli's principle.** Energy considerations require that the kinetic energy per unit mass of a fluid increase as the pressure decreases. This is Bernoulli's principle for cases in which changes in height are not important. Higher fluid speeds are associated with lower pressures. These ideas can be used to explain the curve of a baseball and other phenomena.



$$P + \frac{1}{2} \rho v^2 = \text{constant}$$

Jill Braaten/McGraw-Hill Education

Who knew the behavior of fluids was so complex? The mastery quiz in Connect should help clarify some of these concepts. The practice problems will help with exercises involving computations. They can both be found in Connect.

## Key Terms

Pressure, 171  
 Pascal's principle, 172  
 Atmospheric pressure, 174  
 Density, 174

Boyle's law, 177  
 Buoyant force, 178  
 Archimedes' principle, 178  
 Viscosity, 182

Turbulent flow, 183  
 Bernoulli's principle, 185

## Conceptual Questions

\* = more open-ended questions, requiring lengthier responses, suitable for group discussion

**Q** = sample responses are available in appendix D

**Q** = sample responses are available in Connect

- Q1. Is it possible for a 100-lb woman to exert a greater pressure on the ground than a 250-lb man? Explain.
- Q2. If we measure force in pounds (lb) and distance in feet (ft), what are the units of pressure in this system? Explain.
- Q3.** The same force is applied to two cylinders that contain air. One has a piston with a large area, and the other has a piston with a small area. In which cylinder will the pressure be greater? Explain.
- Q4. A penny and a quarter are embedded in the concrete bottom of a swimming pool filled with water. Which of these coins experiences the greater downward force due to water pressure acting on it? Explain.
- \*Q5. Why are bicycle tires often inflated to a higher pressure than automobile tires, even though the automobile tires must support a much larger weight? Explain.
- Q6.** The fluid in a hydraulic system pushes against two pistons, one with a large area and the other with a small area.
- Which piston experiences the greater force due to fluid pressure acting on it? Explain.
  - When the smaller piston moves, does the larger piston move through the same distance, a greater distance, or a smaller distance than the smaller piston? Explain.
- Q7. If the output piston in a hydraulic pump exerts a greater force than one applied to the input piston, is the pressure at the output piston also larger than that at the input piston? Explain.
- Q8. When a mercury barometer is used to measure atmospheric pressure, does the closed end of the tube above the mercury column usually contain air? Explain.
- \***Q9.** Could we use water instead of mercury to make a barometer? What advantages and disadvantages would be associated with the use of water? Explain.
- Q10. A blood pressure reading is given as 130/75.
- What units are implied by these numbers? (See everyday phenomenon box 9.1.)
  - Are these numbers total pressures or gauge pressures? Explain.
- Q11. Which animal would be expected to have the higher blood pressure: a dog or a giraffe? Explain. (See everyday phenomenon box 9.1.)
- Q12.** If you climbed a mountain carrying a mercury barometer, would the level of the mercury column in the glass tube of the barometer increase or decrease (compared to the mercury reservoir) as you climbed the mountain? Explain.
- Q13. If you filled an airtight balloon at the top of a mountain, would the balloon expand or contract as you descended the mountain? Explain.
- \*Q14. When you go over a mountain pass in an automobile, your ears often "pop" both on the way up and on the way down. How can you explain this effect?
- Q15.** The plunger of a sealed hypodermic syringe containing air is slowly pulled out. Does the air pressure inside the syringe increase or decrease when this happens? Explain.
- Q16. Helium is sealed inside a balloon impermeable to the flow of gas. If a storm suddenly came up, would you expect the balloon to expand or contract? Explain. (Assume there is no change in temperature.)
- Q17. Is it possible for a solid metal ball to float in mercury? Explain.
- Q18.** A rectangular metal block is suspended by a string in a beaker of water, so that the block is completely surrounded by water. Is the water pressure at the bottom of the block equal to, greater than, or less than the water pressure at the top of the block? Explain.
- Q19. Is it possible for a boat made of concrete to float? Explain.
- Q20. A block of wood is floating in a pool of water.
- Is the buoyant force acting on the block greater than, less than, or equal to the weight of the block? Explain.
  - Is the volume of the fluid displaced by the block greater than, less than, or equal to the volume of the block? Explain.
- Q21.** A large bird lands on a rowboat that is floating in a swimming pool. Will the water level in the pool increase, decrease, or remain the same when the bird lands on the boat? Explain.
- Q22. Is it possible for some objects to float in salt water but sink in fresh water? Explain.

- \*Q23. A rowboat is floating in a swimming pool when the anchor is dropped over the side. When the anchor is dropped, will the water level in the swimming pool increase, decrease, or remain the same? Explain.
- Q24. If an object has a smaller density than water, will the object stay fully submerged, become partly submerged, or rise completely out of the water when it is released under water? Explain.
- Q25. A steady stream of water flowing in a narrow pipe reaches a point where the pipe widens. Does the speed of the water increase, decrease, or remain the same when the pipe widens? Explain.
- Q26. Why does the stream of water flowing from a faucet often get more narrow as the water falls? Explain.
- Q27. Does a stream of liquid with a high viscosity flow more rapidly under the same conditions as a stream with low viscosity? Explain.
- Q28. If the speed of flow in a stream decreases, is the flow likely to change from laminar to turbulent flow? Explain.
- Q29. Why is the flow of smoke from a cigarette often laminar near the source but turbulent farther from the source? Explain.
- Q30. If you blow between two limp pieces of paper held hanging down a few inches apart, will the pieces of paper come closer together or move farther apart? Explain.
- \*Q31. A wind gust blows sideways across an outward-swinging door that is slightly ajar. Will this cause the door to slam shut or swing open? Explain.
- Q32. A hair dryer can be used to create a stream of air. Is the air pressure in the center of the stream greater than, less than, or equal to the air pressure at some distance from the center of the stream? Explain.
- Q33. From the perspective of a right-handed batter, does a rising fastball spin clockwise or counterclockwise? Explain. (See everyday phenomenon box 9.2.)
- Q34. Does the path of a curveball really curve? (See everyday phenomenon box 9.2.)

## Exercises

- E1. A force of 60 N pushes down on the movable piston of a closed cylinder containing a gas. The piston's area is  $0.4 \text{ m}^2$ . What pressure does this produce in the gas?
- E2. A 150-lb woman puts all of her weight on one heel of her high-heeled shoes. The heel has an area of  $0.25 \text{ in}^2$ . What is the pressure that her heel exerts on the ground in pounds per square inch (psi)?
- E3. A 270-lb man supports all of his weight on a snowshoe with an area of  $180 \text{ in}^2$ . What pressure is exerted on the snow (in pounds per square inch)?
- E4. The pressure of a gas contained in a cylinder with a movable piston is  $520 \text{ Pa}$  ( $520 \text{ N/m}^2$ ). The area of the piston is  $0.3 \text{ m}^2$ . What is the magnitude of the force exerted on the piston by the gas?
- E5. In a hydraulic system, a force of  $540 \text{ N}$  is exerted on a piston with an area of  $0.002 \text{ m}^2$ . The load-bearing piston in the system has an area of  $0.3 \text{ m}^2$ .
- What is the pressure in the hydraulic fluid?
  - What is the magnitude of the force exerted on the load-bearing piston by the hydraulic fluid?
- E6. The load-bearing piston in a certain hydraulic system has an area 70 times as large as the input piston. If the larger piston supports a load of  $6160 \text{ N}$ , how large a force must be applied to the input piston?
- E7. A column of water in a vertical pipe has a cross-sectional area of  $0.32 \text{ m}^2$  and a weight of  $680 \text{ N}$ . What is the increase in pressure (in Pa) from the top to the bottom of the pipe?
- E8. With the temperature held constant, the pressure of a gas in a cylinder with a movable piston is increased from  $8 \text{ kPa}$  to  $40 \text{ kPa}$ . The initial volume of the gas in the cylinder is  $0.75 \text{ m}^3$ . What is the final volume of the gas after the pressure is increased?
- E9. With the temperature held constant, the piston of a cylinder containing a gas is pulled out, so that the volume increases from  $0.2 \text{ m}^3$  to  $0.5 \text{ m}^3$ . If the initial pressure of the gas was  $90 \text{ kPa}$ , what is the final pressure?
- E10. A  $0.52\text{-kg}$  block of wood is floating in water. What is the magnitude of the buoyant force acting on the block?
- E11. A block of wood of uniform density floats, so that exactly one-quarter of its volume is under water. The density of water is  $1000 \text{ kg/m}^3$ . What is the density of the block?
- E12. A certain boat displaces a volume of  $8.3 \text{ m}^3$  of water. (The density of water is  $1000 \text{ kg/m}^3$ .)
- What is the mass of the water displaced by the boat?
  - What is the buoyant force acting on the boat?
- E13. A rock with a volume of  $0.3 \text{ m}^3$  is fully submerged in water having a density of  $1000 \text{ kg/m}^3$ . What is the buoyant force acting on the rock?
- E14. A stream moving with a speed of  $3.5 \text{ m/s}$  reaches a point where the cross-sectional area of the stream decreases to one-half of the original area. What is the water speed in this narrowed portion of the stream?
- E15. Water emerges from a faucet at a speed of  $1.5 \text{ m/s}$ . After falling a short distance, its speed increases to  $4.5 \text{ m/s}$  as a result of the gravitational acceleration. By what number would you multiply the original cross-sectional area of the stream to find the area at the lower position?
- E16. An airplane wing with an average cross-sectional area of  $8 \text{ m}^2$  experiences a lift force of  $90,000 \text{ N}$ . What is the difference in air pressure, on the average, between the bottom and top of the wing?

## Synthesis Problems

- SP1. Suppose the input piston of a hydraulic jack has a diameter of 3 cm and the load piston a diameter of 24 cm. The jack is being used to lift a car with a mass of 1700 kg.
- What are the areas of the input and load pistons in square centimeters? ( $A = \pi r^2$ )
  - What is the ratio of the area of the load piston to the area of the input piston?
  - What is the weight of the car in newtons? ( $W = mg$ )
  - What force must be applied to the input piston to support the car?
- SP2. Water has a density of  $1000 \text{ kg/m}^3$ . The depth of a swimming pool at the deep end is about 2.4 m.
- What is the volume of a column of water 2.4 m deep and  $0.6 \text{ m}^2$  in cross-sectional area?
  - What is the mass of this column of water?
  - What is the weight of this column of water in newtons?
  - What is the excess pressure (above atmospheric pressure) exerted by this column of water on the bottom of the pool?
  - How does this value compare to atmospheric pressure?
- SP3. A copper block with a density of  $8960 \text{ kg/m}^3$  is suspended from a string in a beaker of water, so that the block is completely submerged but not resting on the bottom. The block is a cube with sides of 4 cm (0.04 m).
- What is the volume of the block in cubic meters?
  - What is the mass of the block?
  - What is the weight of the block?
  - What is the buoyant force acting on the block?
  - What tension in the string is needed to hold the block in place?
- SP4. A flat-bottomed, wooden box is 2.8 m long and 1.3 m wide, with sides 1 m high. The box serves as a boat carrying five people as it floats on a pond. The total mass of the boat and the people is 1600 kg.
- What is the total weight of the boat and the people in newtons?
  - What is the buoyant force required to keep the boat and its load afloat?
  - What volume of water must be displaced to support the boat and its load? (The density of water is  $1000 \text{ kg/m}^3$ .)
  - How much of the boat is under water? (What height of the sides must be submerged to produce a volume equal to that of part c?)
- SP5. A pipe with a circular cross section has a diameter of 9 cm. It narrows at one point to a diameter of 5.2 cm. The pipe is carrying a steady stream of water that completely fills the pipe and is moving with a speed of 1.6 m/s in the wider portion.
- What are the cross-sectional areas of the wide and narrow portions of the pipe? ( $A = \pi r^2$ , and the radius is half the diameter.)
  - What is the speed of the water in the narrow portion of the pipe?
  - Is the pressure in the narrow portion of the pipe greater than, less than, or equal to the pressure in the wider portion? Explain.

## Home Experiments and Observations

- HE1. Using an awl or drill, punch three similar holes in an empty plastic milk jug at three different heights. Plug the holes and fill the jug with water.
- Placing the jug at the edge of the sink, unplug the holes and let the water flow out. Which hole produces the greatest initial speed for the emerging water?
  - Which stream travels the greatest horizontal distance? What factors determine how far the water will go horizontally?
  - Observe the shape of the water streams as they fall into the sink. Do the streams narrow as the water falls? If so, how can this be explained?
- HE2. If you have some modeling clay available, try building a boat from the clay.
- Does the clay sink when it is rolled into a ball? What does this indicate about the density of the clay?
  - Is a flat boat more effective than a canoe in carrying the maximum load of steel washers or other weights? Try them both. What are the problems with each?
- HE3. If you have a hair dryer handy, try supporting a Ping-Pong ball in a vertical column of air coming from the dryer.
- Can you get the Ping-Pong ball to stay in place? How far from the center can the ball wander and still return?
  - Will a tennis ball or a small balloon work? What differences do you note in each of these cases?
- HE4. Using paper clips and a pen or pencil as a support rod, suspend two full-sized pieces of paper a few inches apart, so that they hang vertically.
- Blow downward between the two pieces and observe the effect. How does increasing the spacing affect the results?
  - Try blowing at different rates. How does this affect the results?



# CHAPTER 10

backyardproduction/Zoonar GmbH/Alamy Stock Photo

## Temperature and Heat

### Chapter Overview

The first two sections of this chapter explore the ideas of temperature, heat, and the relationship between these two distinct concepts. We then introduce the first law of thermodynamics, which helps us explain why a drill bit gets hot as it works, as well as many aspects of gas behavior. Finally, we discuss the ways heat is transferred from one object to another.

### Chapter Outline

- 1 Temperature and its measurement.** What is temperature? How do we go about measuring it? Where should we place the zero of a temperature scale?
- 2 Heat and specific heat capacity.** What is heat? How does it differ from temperature? Does adding heat always change the temperature of a substance? How is heat involved in changes of phase?
- 3 Joule's experiment and the first law of thermodynamics.** Are there other ways of changing the temperature of an object besides adding heat? What does the first law of thermodynamics say and mean?
- 4 Gas behavior and the first law.** How can the behavior of gases be explained using the first law of thermodynamics? What is an ideal gas?
- 5 The flow of heat.** What are the different ways that heat can be transferred from one object to another? How do these ideas apply to heating or cooling a house?

**H**ave you ever touched a drill bit right after drilling a hole in a piece of wood or metal (fig. 10.1)? Chances are you removed your hand quickly because the bit was probably hot, particularly if you had been drilling into metal. The same phenomenon is at work when brakes get hot on your bicycle or car, or in any other process where one surface is rubbing on another.

We could also make the drill bit hot by placing it in a pot of boiling water or into the flame of a blowtorch. In either case, when the bit gets hotter, we say its temperature has increased. What is temperature, though, and how do we go about comparing one temperature to another? Is the final condition of the drill bit any different if it has been warmed by drilling rather than by being placed in contact with hot water?

Questions such as these lie in the realm of **thermodynamics**, the study of heat and its effects on matter. Our earlier discussion of energy in chapter 6 was limited to mechanical energy. The first law of thermodynamics, introduced in this chapter, extends the principle of conservation of energy to include the effects of heat.

What is the difference between heat and temperature? Our everyday language often blends these two ideas. A true appreciation for this distinction did not emerge until about the middle of the nineteenth century, when the laws of thermodynamics were developed. Heat, temperature, and the distinction between them are critical, however, to understanding why things get hot or cold and why some remain



**Figure 10.1** The drill bit feels hot after drilling a hole in a piece of metal. What causes the increase in its temperature?

*James Ballard/McGraw-Hill Education*

that way longer than others. The same ideas involved in cooling a drink are important to understanding global weather patterns.

## 10.1 Temperature and Its Measurement

Suppose that, as a child, you were not feeling well and were looking for an excuse to skip school. You thought you might have a fever, and your mother, by placing a hand on your forehead, agreed that you felt a little hot. To confirm this hunch, however, she took your temperature (fig. 10.2). She told you that you had a temperature of  $101.3^{\circ}$ .

What exactly did this tell you? Because units are important, but often unstated, the measurement indicated that your body temperature was  $101.3^{\circ}$  Fahrenheit. This is above  $98.6^{\circ}\text{F}$ , which is generally considered normal, so you had a fever. (In most other parts of the world, your temperature would have been read as  $38.5^{\circ}$  Celsius, above the normal temperature of  $37.0^{\circ}\text{C}$ .) You were probably justified in spending the rest of the day in bed. A thermometer provides a quantitative measure of how hot or cold things are and a basis for comparing your current temperature to your normal temperature. This quantitative measure usually carries more credibility with a boss or professor than the vaguer statement that you felt like you had a fever.

### How do we measure temperature?

Taking a temperature or reading a thermometer is a common experience. Besides the obvious function of comparing the “hotness” or “coldness” of different objects, however, do the



**Figure 10.2** Taking a temperature. What does the thermometer tell us?

*Getty Images*

numbers have any more fundamental meaning? To ask a basic question, how do hot objects differ from cold objects? What is *temperature*?

Although we all have an intuitive feel for what hot and cold mean, putting that impression into words can be hard. Try it before you read on: How would you define the term *hot*? Even our senses can mislead us. The pain we feel when we touch something very hot can be hard to distinguish from

the pain we feel when we touch a very cold object. A metal block feels colder to the touch than a wooden block, even if the two blocks have the same temperature. In the end, temperature measurement is a comparison, and the comparative terms *hotter* and *colder* have more meaning than *hot* or *cold* themselves.

A closer look at what happens when we use a thermometer is helpful. Traditionally, a clinical thermometer was a sealed glass tube partially filled with some fluid, usually mercury. (These have now been largely replaced by digital thermometers.) The inside diameter of the tube was very small, but it widened at the bottom into a reservoir containing most of the mercury (fig. 10.3). Usually, you placed the thermometer in your mouth under your tongue and waited a few minutes until the thermometer reached the same temperature as the inside of your mouth. At first, the mercury rose in the thin tube. When the mercury level in the tube was no longer changing, you assumed it had reached the same temperature as your mouth.

Why does the mercury rise? Most materials expand as they get warmer, and mercury and many other liquids expand at a greater rate than glass. As it expands, the mercury in the reservoir must go somewhere, so it rises in the narrow tube. We use the physical property of the thermal expansion of mercury to give an indication of temperature; by placing marks along the tube, we create a temperature scale. Any other physical property that changes with temperature could, in principle, be used. Such properties include changes in electrical resistance, thermal expansion of metals, and even changes in color.

In this whole process, we assume that if two objects are in contact with each other long enough, so that the physical properties (such as volume) of the objects are no longer changing, the two objects have the same temperature. When



**Figure 10.3** The traditional clinical thermometer contained mercury in a thin glass tube with a wider reservoir of mercury at the bottom.

Keith Eng, 2008

we take a temperature with a clinical thermometer, we wait until the mercury stops rising before reading the thermometer. Likewise, when using a digital thermometer we often wait for a beep, signaling that the temperature is no longer changing. This procedure gives us part of the definition of temperature by defining when two or more objects have the *same* temperature. When the physical properties are no longer changing, the objects are said to be in **thermal equilibrium**. Two or more objects in thermal equilibrium have the same temperature. This assumption is sometimes referred to as the **zeroth law of thermodynamics**, because it underlies the definition of temperature and the process of temperature measurement.

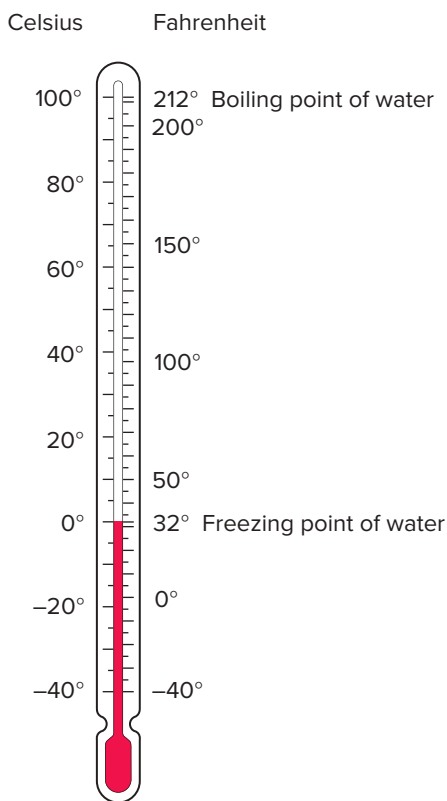
### How were temperature scales developed?

What do the numbers on a thermometer mean? When the first crude thermometer was made, the numbers marking the divisions on the scale were arbitrary. They were useful for comparing temperatures only when the *same* thermometer was used. To compare a temperature measured in Germany with one thermometer to another measured in England with a different thermometer, a standard temperature scale was needed.

The first widely used temperature scale was devised by Gabriel Fahrenheit (1686–1736) in the early 1700s. Anders Celsius (1701–1744) invented another widely used scale somewhat later, in 1743. Both of these scales use the freezing point and boiling point of water to anchor the scales. The modern Celsius scale uses the triple point of water, where ice, water, and water vapor are all in equilibrium. This point varies only slightly from the freezing point at normal atmospheric pressure. Fahrenheit set the freezing point of water at  $32^\circ$  and the boiling point at  $212^\circ$  on his scale. These two points are set at  $0^\circ$  and  $100^\circ$  on the Celsius scale (fig. 10.4).

As figure 10.4 shows, the Celsius degree is larger than the Fahrenheit degree. Only 100 Celsius degrees span the temperature range between the freezing point and boiling point of water, while 180 Fahrenheit degrees ( $212^\circ - 32^\circ$ ) are needed to span the same range. The ratio of Fahrenheit degrees to Celsius degrees is therefore  $\frac{180}{100}$ , or  $\frac{9}{5}$ . The Fahrenheit degree is five-ninths the size of the Celsius degree, so more Fahrenheit degrees are needed to cover the same range in temperature.

The Celsius scale is used in science and in most of the world. Because Fahrenheit temperatures are still more familiar in the United States, we commonly have to convert from one scale to the other. Because the zero points and the size of the degree differ, we take both factors into account in the conversion. For example, an ordinary room temperature of  $72^\circ$  Fahrenheit is  $40^\circ$  above the  $32^\circ$ F freezing point of water. Because it takes only five-ninths as many Celsius degrees to span the same range, this temperature is  $(\frac{5}{9})(40^\circ)$ , or 22 Celsius degrees above the freezing point of water. The Celsius



**Figure 10.4** The Fahrenheit and Celsius scales use different numerical values for the freezing and boiling points of water. The Celsius degree is larger than the Fahrenheit degree.

scale has its zero at the freezing point of water, so  $72^{\circ}\text{F}$  is equal to  $22^{\circ}\text{C}$ .

Let's recap. First, we found how many Fahrenheit degrees this temperature is above the freezing point of water by subtracting 32. Then, we multiplied by the factor  $\frac{5}{9}$ , which is the ratio of the size of the Fahrenheit degree to the Celsius degree. We know it takes fewer Celsius degrees to span this range because the Celsius degree is larger than the Fahrenheit degree. We can express this conversion in an equation:

$$T_C = \frac{5}{9}(T_F - 32)$$

Using the same logic to perform the reverse conversion from Celsius to Fahrenheit, or simply rearranging the equation, it becomes

$$T_F = \frac{9}{5}T_C + 32$$

Multiplying the temperature in Celsius by  $\frac{9}{5}$  tells us how many Fahrenheit degrees above the freezing point it is. This value then is added to  $32^{\circ}\text{F}$ , the freezing point on the Fahrenheit scale. Using this relationship, you can confirm that the boiling point of water ( $T_C = 100^{\circ}\text{C}$ ) equals  $212^{\circ}\text{F}$ . Normal body temperature ( $98.6^{\circ}\text{F}$ ) is equivalent to  $37^{\circ}\text{C}$ . A body temperature of  $39^{\circ}\text{C}$  would be enough to keep you home from school or work.

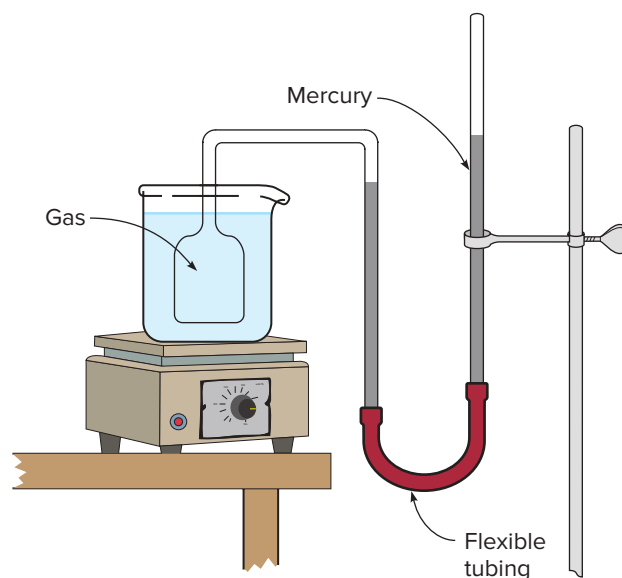
### Is there an absolute zero?

Do the zero points on either scale have any special significance? Although the zero point on the Celsius scale is the freezing point of water, there is no special significance to these points. In fact, the temperature reading can drop well below zero on either scale, as happens frequently in places such as Siberia and Alaska in the winter. Fahrenheit's zero point was based on the temperature of a mixture of salt and ice in a saturated salt solution.

Although the zero points of both the Fahrenheit and Celsius scales were selected arbitrarily, there is an absolute zero with more fundamental significance. Absolute zero was not proposed until 100 years or so after these scales were originally developed.

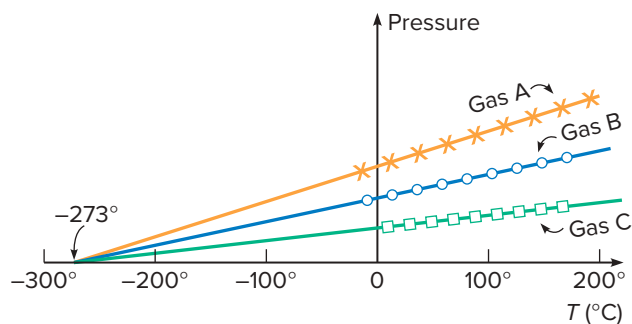
The first indication of an absolute zero for temperature measurements came from studying changes in pressure and volume that take place in gases when the temperature is changed. If we hold the volume of a gas constant while increasing the temperature, the pressure of the gas will increase. Pressure is another physical property that changes with temperature, just like the volume of mercury in the case of a mercury thermometer. (See chapter 9 for a discussion of pressure.) Because the pressure of a gas of constant volume increases with temperature, we can use this property as a means of measuring temperature.

The pressure of the gas in the large bulb submerged in the water in figure 10.5 will increase as the temperature of the water is increased. This increase in pressure can be read by measuring the difference in height of the two mercury



**Figure 10.5** This constant-volume gas thermometer is measuring the temperature of the liquid in the flask by measuring the difference in height of the two mercury columns (which is proportional to the pressure of the gas).





**Figure 10.6** The pressure plotted as a function of temperature for different amounts of different gases. When extended backward, the lines all intersect the temperature axis at the same point regardless of gas type or quantity.

columns. The flexible tube connecting the two columns allows the right-hand column to be moved up or down to keep the volume of the gas in the bulb and connecting tube constant. These are the essential features of a constant-volume gas thermometer.

If we plot the pressure of a gas as a function of the temperature measured on the Celsius scale, we get a graph like figure 10.6. If the temperatures and pressures are not too high, a striking feature emerges from such graphs. The curves for different gases or amounts all are straight lines, and when these lines are extended backward to zero pressure, they all intersect the temperature axis at the same point. This is true regardless of the gas used (oxygen, nitrogen, helium, and so on) or the quantity of gas.

The curves all intersect the axis at  $-273.2^{\circ}\text{C}$ . Because a negative pressure has no meaning, this intersection suggests that the temperature cannot get any lower than  $-273.2^{\circ}\text{C}$ . It is important to keep in mind that most gases will condense to liquids and then solidify well before this point is reached.

We refer to this temperature,  $-273.2^{\circ}\text{C}$ , as **absolute zero**. The Kelvin, or absolute, temperature scale has its zero at this point and uses intervals the same size as the Celsius degree. To convert Celsius temperatures to kelvins, we simply add 273.2 to the Celsius temperature, or

$$T_K = T_C + 273.2$$

Room temperature of  $22^{\circ}\text{C}$  is an **absolute temperature** of approximately 295 K. (The term *degree* and the degree symbol are not used in expressing absolute temperatures; they are simply called *kelvins*.) The absolute temperature scale currently in use is basically the same as the one originally suggested by observing the behavior of gases.

As we cool a substance to near absolute zero, all molecular motion is ceasing. Absolute zero is a temperature we can approach but never really reach. It represents a limiting value. Speaking of anything getting any colder than absolute zero is not meaningful.

Temperature measurements are based on physical properties that change with temperature, such as the volume of a liquid or the pressure of a gas. The Fahrenheit and Celsius scales have different zero points and different-sized degrees. The Kelvin, or absolute, scale starts at absolute zero and uses intervals the same size as the Celsius degree.

## 10.2 Heat and Specific Heat Capacity

You are already late for class or work, but your morning cup of coffee is too hot to drink. What can you do to cool it to the point where you won't scald your tongue? You can blow on it, but blowing is not a very efficient way of cooling coffee quickly. If you take milk with your coffee, you can pour a little cold milk into the cup, and the temperature of the coffee will be lowered (fig. 10.7).

What happens when objects or fluids at different temperatures come in contact with each other? The temperature of the colder object increases, and the temperature of the warmer one decreases, with both objects eventually coming to the same intermediate temperature. Something is flowing from the hotter to the colder body (or vice versa). But what is flowing?

### What is specific heat capacity?

Early attempts at explaining phenomena like our coffee-cooling example involved the idea that an invisible fluid



**Figure 10.7** Pouring cold milk into a hot cup of coffee lowers the temperature of the coffee.

Jill Braaten/McGraw-Hill Education

called *caloric* flowed from the hotter to the cooler object. The amount of caloric transferred dictated the extent of the temperature change. Different materials were thought to store different amounts of caloric in the same amount of mass, which helped to explain some observations. Although the caloric model successfully explained many simple phenomena involving temperature changes, there were also problems with it, which we will discuss in section 10.3.

We now use the term **heat** for the quantity of energy that flows from one object to another when two objects of different temperatures come in contact. As we will see in section 10.3, heat flow is a form of energy transfer between objects.

The idea of exchange of heat sheds light on a large variety of phenomena. If you drop a 100-gram steel ball, initially at room temperature, into your cup of coffee, you will find it is less effective at cooling your coffee than 100 grams of room-temperature milk or water. Steel has a lower **specific heat capacity** than milk or water. (Milk is mostly water, as is coffee.) Less heat is needed to change the temperature of 100 grams of steel than to change the temperature of an equal mass of water by the same amount.

The specific heat capacity of a material is the quantity of heat needed to change a unit mass of the material by a unit amount in temperature (for example, to change 1 gram by 1 Celsius degree). It is a property of the material.

The specific heat capacity of a material is the relative amount of heat needed to raise its temperature. This number is determined experimentally for each substance. For example, the specific heat capacity of water is 1 cal/g·C°—that is, it takes 1 calorie of heat to raise the temperature of 1 gram of water 1°C. The *calorie* is a commonly used unit of heat. It is defined as the quantity of heat required to raise the temperature of 1 gram of water 1 Celsius degree. Likewise, if 1 calorie is removed from 1 gram of water, its temperature decreases 1°C. Water happens to have an unusually large specific heat capacity. Therefore, we use water as a reference material for measuring the specific heat capacities of other materials, a few of which are listed in table 10.1.

The specific heat capacity of steel is approximately 0.11 cal/g·C°, much less than that of water. Dropping 100 grams of room-temperature steel shot into our cup of coffee is much less effective in cooling the coffee than pouring 100 grams of room-temperature water into the cup. For each degree of temperature change, the steel absorbs less heat from the coffee than the water (fig. 10.8).

When the cold steel is dropped into the hot water, heat flows from the water into the steel shot. From the definition of specific heat capacity, we can find how much heat must be absorbed by the steel to change its temperature by a given

**Table 10.1**

Specific Heat Capacities of Some Common Substances

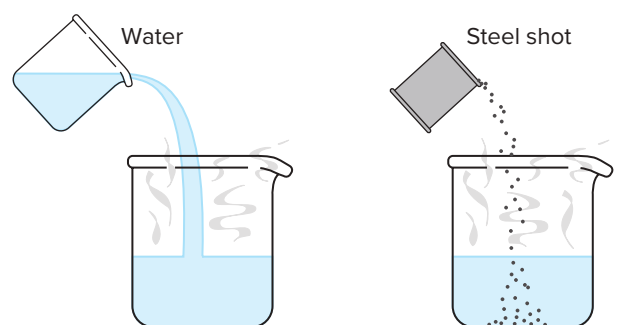
Substance	Specific Heat Capacity in cal/g·C°
Water	1.0
Ice	0.49
Steam	0.48
Ethyl alcohol	0.58
Glass	0.20
Granite	0.19
Steel	0.11
Aluminum	0.215
Lead	0.0305

amount. Because specific heat capacity is the amount of heat per unit mass per unit temperature change, the total heat required is

$$Q = mc\Delta T$$

where  $Q$  is the standard symbol for a quantity of heat,  $m$  is the mass,  $c$  is the symbol for specific heat capacity, and  $\Delta T$  is the change in temperature. Because the specific heat capacity  $c$  is much larger for water than for steel, a larger quantity of heat is needed to warm 100 grams of water to a given temperature than is needed to warm 100 grams of steel. Because this heat comes from the hot coffee, water is more effective than steel in cooling the coffee.

The large specific heat capacity of water is partly responsible for its moderating effect on temperatures near the coast of an ocean or large lake. A large body of water, with its large specific heat capacity, requires the addition or removal of a large quantity of heat to change its temperature. The body of water will have a moderating influence on the air temperature in its vicinity. Nights will be warmer and days cooler than at some distance inland, because it is difficult to change the temperature of the water.



**Figure 10.8** One hundred grams of room-temperature water (20°C) is more effective than 100 grams of room-temperature steel shot in cooling a hot beaker of water.

### What is the distinction between heat and temperature?

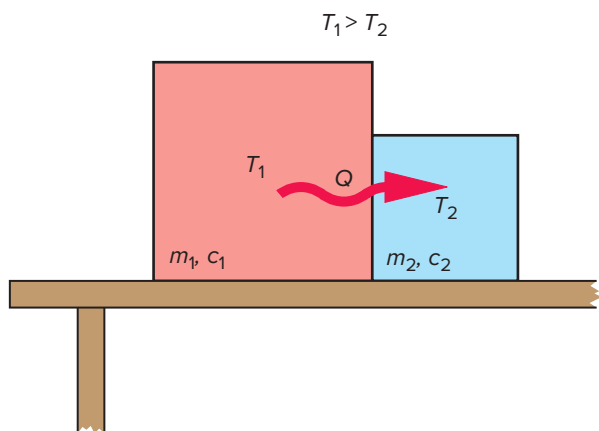
When two objects at different temperatures are placed in contact, heat will flow from the object with the higher temperature to the one with the lower temperature (fig. 10.9). Heat added increases the temperature, and heat removed decreases the temperature—heat and temperature are not the same. The quantity of heat added or removed,  $Q$ , to produce a given change in temperature,  $\Delta T$ , depends on the amount of material involved (its mass) and the specific heat capacity of the material.

**Temperature** is a quantity that tells us which direction the heat will flow. If two objects are at the same temperature, no heat will flow. Heat flows from the hotter object to the colder one when two objects at different temperatures are placed in contact. The quantity of heat transferred depends on the temperature difference between the two materials, as well as on their masses and specific heat capacities.

Heat and temperature are closely related concepts but play different roles in our explanation of heating and cooling processes:

Heat is energy that flows from one object to another when there is a difference in temperature between the objects.

Temperature is the quantity that indicates whether or not, and in which direction, heat will flow. Objects at the same temperature are in thermal equilibrium with each other, and no heat will flow from one to the other.



**Figure 10.9** Heat flows from the hotter object to the colder one when two objects at different temperatures are placed in contact. The changes in temperature that result depend on the quantities of material and the specific heat capacity of each object.

### How is heat involved in melting or freezing?

Can heat be added to or removed from a substance without changing the temperature at all? This does indeed occur when substances go through a **change of phase**. The melting of ice and the boiling of water are the most familiar examples of changes in phase. Whenever we cool a drink using ice or boil water for tea or coffee, we produce changes of phase. What happens?

Ice, liquid water, and water vapor are different *phases* of the same substance, water. If the temperature of water is cooled to  $0^\circ\text{C}$ , and we continue to remove heat, the water will freeze into ice. Likewise, if we warm ice to  $0^\circ\text{C}$  and continue to add heat, the ice will melt (fig. 10.10). As we add heat, the temperature of the ice and water remains at  $0^\circ\text{C}$  while the melting is taking place. Heat is being added, but no change in temperature occurs. Apparently, adding or removing heat produces changes other than just temperature changes.

Careful measurements have shown that it takes approximately 80 calories of heat to melt 1 gram of ice. This ratio,



**Figure 10.10** Adding heat to a mixture of water and ice at  $0^\circ\text{C}$  melts the ice without changing the temperature of the mixture.

Jill Braaten

80 cal/g, is referred to as the *latent heat of fusion* of water and is often denoted by the symbol  $L_f$ . **Latent heat** changes the *phase* of water without changing its temperature. Likewise, approximately 540 calories of heat is required to turn 1 gram of water at 100°C into steam. This ratio, 540 cal/g, is called the *latent heat of vaporization*,  $L_v$ . These values are valid only for water. Other substances have their own particular latent heats of fusion and vaporization. See everyday phenomenon box 10.1 for an interesting application of these ideas.

What happens when we cool a glass of water by adding ice? At first, the ice and water are at different temperatures, the ice somewhere below 0°C and the water somewhere above this temperature. Heat flows from the water to the ice until the ice reaches a temperature of 0°C. At this point, the ice begins to melt as heat continues to flow from the water to the ice. If enough ice is present, this flow of heat will proceed until the water also reaches a temperature of 0°C. Example box 10.1 illustrates these ideas.

If the glass were well insulated, so that heat could not flow into the glass from the warmer surroundings, the ice and water mixture would remain at 0°C after both the water and the ice had reached this temperature, and no more ice would melt. Usually, though, heat flows into the system from the surroundings, and the ice continues to melt more

slowly. Once the ice is gone, the drink will begin to warm and will eventually reach room temperature as heat flows in from the surrounding air.

An ice-water mixture, well stirred, remains at 0°C once it reaches thermal equilibrium. Small quantities of heat may flow into or out of the mixture from the surroundings, and small quantities of ice may melt or freeze, but the temperature will not change. This is one reason the temperature 0°C is useful as a reference point for our temperature scales. It is a stable and reproducible temperature.

When we cook food by boiling, we take advantage of the fact that water boils at 100°C—and that we can continue to add heat *without* changing the temperature. Adding heat from the burner causes the liquid water to change to water vapor while the temperature remains at 100°C. Because the temperature is constant, the cooking time required to boil an egg or a potato is also fairly constant, depending on the size of the egg or potato.

Cooks should be aware, however, of the effects of altitude on the boiling temperature. In cities such as Denver, Colorado, or Albuquerque, New Mexico, both located approximately a mile above sea level, water boils at a temperature of about 95°C because of the lower atmospheric pressure at this altitude. In Mexico City, at an elevation of about 1.4 miles above sea level, the temperature is even lower, about 93°C. It takes longer to boil an egg or potato in these places than near sea level, where the boiling point is 100°C. If you do not make the adjustment in cooking time, your potatoes will be crunchy in the center.

Another familiar phenomenon involving the latent heat of vaporization is that of cooling by perspiration (sweating). The cooling is caused by evaporation, the fact that the sweat on your skin changes from a liquid to a vapor. Heat is drawn from your body to provide the heat of vaporization needed to evaporate the sweat, thus cooling your body. One of the reasons we find climates of high humidity so uncomfortable is that the greater amount of water vapor in the air inhibits the evaporation of sweat from our bodies.

### Example Box 10.1

#### Sample Exercise: Changing Ice to Water

If the specific heat capacity of ice is 0.5 cal/g·C°, how much heat will have to be added to 200 g of ice, initially at a temperature of −10°C, to

- Raise the ice to the melting point?
- Completely melt the ice?

a. Heat required to raise the temperature:

$$m = 200 \text{ g} \quad Q = mc\Delta T$$

$$c = \frac{0.5 \text{ cal}}{\text{g}\cdot\text{C}^\circ} \quad = (200 \text{ g})\left(\frac{0.5 \text{ cal}}{\text{g}\cdot\text{C}^\circ}\right)(10^\circ\text{C})$$

$$T = -10^\circ\text{C} \quad = \mathbf{1000 \text{ cal}}$$

$$Q_{\text{raise}} = ?$$

b. Heat required to melt the ice:

$$L_f = \frac{80 \text{ cal}}{\text{g}} \quad Q = mL_f$$

$$Q_{\text{melt}} = ? \quad = (200 \text{ g})\left(\frac{80 \text{ cal}}{\text{g}}\right)$$

$$= \mathbf{16,000 \text{ cal}}$$

The total heat required to raise the ice to 0°C *and* to melt it is

$$1000 \text{ cal} + 16,000 \text{ cal} = \mathbf{17,000 \text{ cal}}, \text{ or } 17 \text{ kcal}$$

Temperature changes can be caused by the flow of energy as heat from one object to another. The amount of heat required to produce a given change in temperature depends on the mass and specific heat capacity of the object, as well as the temperature change. Temperature is a quantity that tells us when and in which direction heat will flow: Heat flows from the hotter to the cooler body. When a substance changes phase, as from ice to water or water to steam, heat is added or removed without changing the temperature. The amount of heat needed per unit mass to produce a phase change is called the latent heat.

## Everyday Phenomenon

## Box 10.1

## Heat Packs

**The Situation.** Heat packs are available in stores in a variety of configurations, including the simple hand warmers shown in the photograph. Without batteries or other obvious sources of energy, they can generate heat on demand to warm cold hands on a winter day.

Their operation is fun to watch and, on first glance, appears amazing. The heat pack consists of a liquid in a clear plastic sack that also contains a small metal disk. When you flex the disk with your fingers, a sudden change occurs. The liquid freezes, starting from the disk and spreading rapidly across the entire pack. In the process, the heat pack warms up, providing welcome heat to your hands. What is happening here?



Jill Braaten

**The Analysis.** Although there are disposable heat packs that operate on a different principle, the reusable heat packs like that pictured here usually contain a simple chemical compound, sodium acetate. This compound is a salt of acetic acid, more commonly known as vinegar. (See chapter 18 for a discussion of

chemical compounds and reactions.) More precisely, it is actually a supersaturated solution of sodium acetate in water.

The melting point of sodium acetate is about 54 to 58°C (129 to 136°F). This is well above normal room temperature, but the sodium acetate in the heat pack is still liquid even at temperatures below room temperature. Why is this so? It turns out that the sodium acetate solution can be readily *supercooled*. This means that it will not freeze unless there is a seed crystal (or nucleus) of the frozen material already present. In the absence of the seed crystal, the material will not freeze when cooled below its melting point, and we say that it is supercooled. This is a common behavior for many materials, including water—water can often be supercooled 5 to 10 Celsius degrees below its melting point of 0°C. In the case of the sodium acetate solution, the liquid can be supercooled to temperatures far below room temperature.

How does the heat pack release heat? Flexing the metal disk in the pack produces a local compression that causes seed crystals to form near the disk. These crystals of frozen sodium acetate start growing at the disk, and because the liquid is supercooled, they grow very rapidly. When a liquid freezes, it releases the latent heat of fusion associated with the phase change from liquid to solid. It is this latent heat that causes the pack to warm up and provide heat to your hands. Surprising as it may seem, it is the freezing process that releases the heat.

To recharge the heat pack, it is necessary to heat the pack above the melting point using a microwave oven or pot of hot water. This causes the crystals to melt, absorbing the latent heat of fusion in the process. If we have eliminated all of the frozen material, the liquid will become supercooled again when we allow the pack to cool, and the heat pack is once again ready for action. What we have is essentially a mechanism for storing heat energy.

The ability to store heat energy is important in many applications. When we use solar energy to heat a house, for example, the greatest need for heat is often in the evening or the early morning when the sun is not shining. Heat collected during the day can be stored in stone or concrete features in the structure of the house, or perhaps in tanks of water underneath the house. However, phase-change storage using sodium acetate or similar compounds permits more heat to be stored in a more compact manner.

Heat storage is a critical consideration in thermal-electric solar power plants (see section 11.4 in chapter 11). Because the energy coming from the sun is highly variable over the course of a day and nonexistent during the night, it is desirable to even out the energy flow to the turbines that generate the electric power. Phase-change materials (referred to as PCMs in the solar-power industry) are now being considered and utilized for this purpose. Sodium acetate is just one of many materials that can be used for heat storage. Other PCMs are more suitable for the higher temperatures encountered in solar power plants.

### 10.3 Joule's Experiment and the First Law of Thermodynamics

Can the temperature of an object be increased without placing the object in contact with a warmer object? What is going on when things get warmer from rubbing? These questions were a subject of scientific debate during the first half of the nineteenth century. Their resolution came about through the experimental work of James Prescott Joule (1818–1889), which was followed by the statement of the first law of thermodynamics around midcentury.

One of the first persons to raise these questions forcefully was colorful American-born scientist and adventurer Benjamin Thompson (1753–1814), also known as Count Rumford. Thompson, finding himself on the losing side of the American Revolutionary War, migrated to Europe, where he served the king of Bavaria as a consultant on weaponry. In Bavaria, he received the title Count Rumford. From his experience in supervising the boring of cannon barrels, Rumford knew firsthand that the barrels and drill bits became quite hot during drilling (fig. 10.11). He once demonstrated that water could be boiled by placing it in contact with the cannon barrel as it was being drilled.

What was the source of the heat that caused the increase in temperature? No hotter body was present that heat might flow from. Horses were used to turn the drill, but their temperature, although warm, was certainly below the boiling



**Figure 10.11** Rumford's cannon-drilling apparatus. What is the source of heat that raises the temperature of the drill and the cannon barrel?

Sheila Terry/Science Source

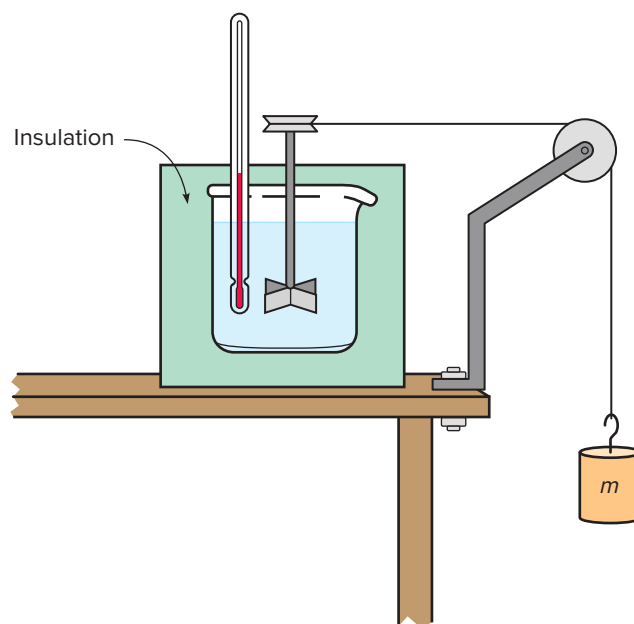
point of water. The horses performed mechanical work on the drilling engine. Was this work capable of generating heat?

#### What did Joule's experiments show?

Rumford's demonstration took place in 1798 and was discussed by many scientists during the early part of the nineteenth century. Quantitative research on Rumford's observations was not done until the 1840s, when Joule performed a famous series of experiments. Joule showed that various ways of performing mechanical work on a system had a consistent and predictable effect in raising the temperature of the system.

In the most dramatic of Joule's experiments, he turned a simple paddle wheel in an insulated beaker of water and measured the increase in temperature (fig. 10.12). A system of weights and pulleys turned the paddle wheel, transferring energy from the weights to the water. As the weights fell, losing gravitational potential energy, the paddle wheel did work against the resisting viscous forces of the water. This work was equal to the loss in potential energy of the weights.

A thermometer placed in the water measured the increase in temperature. Joule found that 4.19 J of work was required to raise the temperature of 1 gram of water by 1°C. (The use of the joule [J] as an energy unit did not come about until well after Joule's work. He stated his results in more archaic energy units. See chapter 6 for the definition of the joule.) Because we can also raise the temperature of 1 gram of water 1°C by adding 1 calorie of heat, Joule's experiment implies that 4.19 J of work is equivalent to 1 calorie of heat.



**Figure 10.12** A falling mass turns a paddle in an insulated beaker of water in this schematic representation of Joule's apparatus for measuring the temperature increase produced by doing mechanical work on a system.

Joule used several ways of performing work in his experiments, as well as several kinds of systems. The results were always the same: 4.19 J of work produced the same temperature increase as 1 calorie of heat. The final state of the system provided no clue as to whether the temperature was increased by adding heat or by doing mechanical work.

### The first law of thermodynamics

At the time of Joule's work, several people had already suggested that the transfer of heat was a transfer of kinetic energy between the atoms and molecules of the systems involved. Joule's experiments supported this view and led directly to the statement of the first law of thermodynamics. The idea underlying the first law is that both work and heat represent transfers of energy into or out of a system.

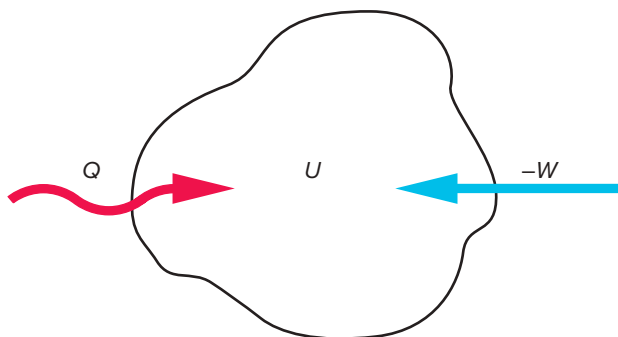
If energy is added to a system either as work or as heat, the *internal energy* of the system increases accordingly. The change in internal energy is equal to the net amount of heat and work transferred into the system. An increase in temperature is one way an increase in internal energy might show up. The **first law of thermodynamics** summarizes these ideas:

The increase in the internal energy of a system is equal to the amount of heat added to a system minus the amount of work done *by* the system.

In symbols, we often write the first law of thermodynamics as

$$\Delta U = Q - W$$

where  $U$  represents the internal energy of the system,  $Q$  represents the amount of heat added to the system, and  $W$  represents the amount of work done *by* the system (fig. 10.13). The minus sign in this statement is a direct result of the convention of choosing work done *by* the system to be positive rather than work done *on* the system. Work done on the system adds energy to the system, but work done by the system on its surroundings removes energy from the system and reduces the internal energy. This sign convention is convenient for discussing heat engines, the main focus of chapter 11.



**Figure 10.13** The internal energy  $U$  of a system is increased by the transfer of either heat or work into the system.

On its surface, the first law seems like a statement of conservation of energy, and indeed it is. Its apparent simplicity obscures the important insights that it contains. First and foremost among these insights is that heat flow is a transfer of energy, an idea strongly reinforced by Joule's experiments. Before 1850, the concept of energy had been restricted to mechanics. In fact, it was only then coming into its own in mechanics and did not play an important role in Newton's original theory. The first law of thermodynamics extended the concept of energy into new areas.

### What is internal energy?

The first law also introduced the concept of the **internal energy** of a system. An increase in internal energy can show up in a variety of ways: One is an increase in temperature, as in Joule's experiment with the paddle wheel. A temperature increase is related to an increase in the average kinetic energy of the atoms or molecules making up the system.

A change in phase, such as melting or vaporization, is another way an increase in the internal energy of a system affects the system. In a phase change, the average *potential* energy of the atoms and molecules is increased as the atoms and molecules are pulled farther away from each other. No temperature change occurs, but there is still an increase in internal energy.

An increase in internal energy, then, can show up as an increase in either the kinetic energy or the potential energy (or both) of the atoms or molecules making up the system:

The internal energy of the system is the sum of the kinetic and potential energies of the atoms and molecules making up the system.

Internal energy is a property of the system uniquely determined by the state of the system. If we know that the system is in a certain phase, and the temperature, pressure, and quantity of material are specified, there is only one possible value for the internal energy. The amount of heat or work that has been transferred to the system, on the other hand, is not uniquely determined by its state. As Joule's experiment showed, *either* heat or work could be transferred to the beaker of water to produce the same increase in temperature.

The system under study can be anything we wish it to be—a beaker of water, a steam engine, or an elephant. It is best, however, to consider a system that has distinct boundaries, so that we can easily define where it begins and ends. Choosing the system is similar to the process of isolating an object in mechanics to apply Newton's second law. In mechanics, forces define the interaction of the chosen object with other objects. In thermodynamics, the transfer of heat or work defines the interaction of a system with other systems or the surroundings.

Example box 10.2 applies the first law of thermodynamics. The system is a beaker containing water and ice (fig. 10.14). The internal energy of the system is increased by both heating on a hot plate and doing work by stirring.

## Example Box 10.2

### Sample Exercise: Applying the First Law of Thermodynamics

A hot plate is used to transfer 400 cal of heat to a beaker containing ice and water. 500 J of work is also done on the contents of the beaker by stirring.

- What is the increase in internal energy of the ice-water mixture?
- How much ice melts in this process?

a. We first convert the heat units to joules:

$$\begin{aligned} Q &= 400 \text{ cal} & Q &= (400 \text{ cal}) (4.19 \text{ J/cal}) \\ W &= -500 \text{ J} & &= 1680 \text{ J} \\ \Delta U &=? & \Delta U &= Q - W \\ & & &= 1680 \text{ J} - (-500 \text{ J}) \\ & & &= \mathbf{2180 \text{ J}} \end{aligned}$$

$$\begin{aligned} \text{b. } L_f &= 80 \text{ cal/g} & \Delta U &= mL_f \\ &= 335 \text{ J/g} & & \\ m &=? & m &= \frac{\Delta U}{L_f} \\ & & &= \frac{2180 \text{ J}}{335 \text{ J/g}} \\ & & &= \mathbf{6.5 \text{ g}} \\ & & & \text{(amount of ice melted)} \end{aligned}$$

Because the internal energy was expressed in joules, we converted the latent heat to units of J/g by multiplying by 4.19 J/cal.

Notice that the work done by stirring is a negative quantity, because it represents work done *on* the system. The increase in internal energy results in the melting of the ice.

### Counting food calories

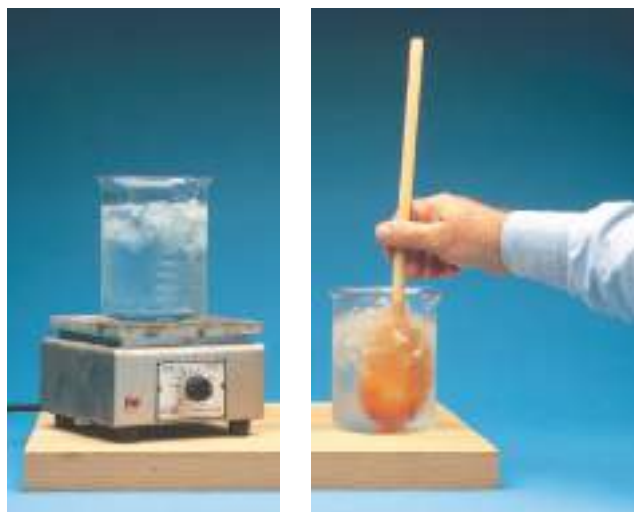
A final note on energy units is worth mentioning. When we eat food, we add energy to our system by taking in material that can release potential energy in chemical reactions. We often measure that energy in a unit called a *Calorie*. This unit is actually a kilocalorie, or 1000 calories. The calorie counting that is done for food uses this unit:

$$1 \text{ Cal} = 1 \text{ kilocalorie} = 1000 \text{ cal}$$

The capital C used in the abbreviation indicates that this is a larger unit than the ordinary calorie.

Caloric values given for different types of food are the amount of energy these foods release when they are digested and metabolized. This energy may be stored in various ways within the body, including fat cells. Our bodies are constantly converting energy stored in muscles to other forms of energy. When we do physical work, for example, we transfer mechanical energy to other systems and warm the surroundings by heat flow from our bodies. When you count calories, you are counting energy intake. If your output is less than your intake, you should expect to get larger.

Joule discovered that doing 4.19 joules of work on a system increased the temperature of the system by the same amount as adding 1 calorie of heat. This discovery convinced scientists that the flow of heat was a form of energy transfer and led to the statement of the first law of thermodynamics. The first law says that the change in the internal energy of a system is equal to the net amount of heat and work transferred into the system. The internal energy is the sum of the kinetic and potential energies of the atoms making up the system. These ideas extend the principle of conservation of energy.



**Figure 10.14** The ice in the beaker can be melted either by adding heat from a hot plate or by doing work stirring the ice and water mixture.

(both): James Ballard/McGraw-Hill Education

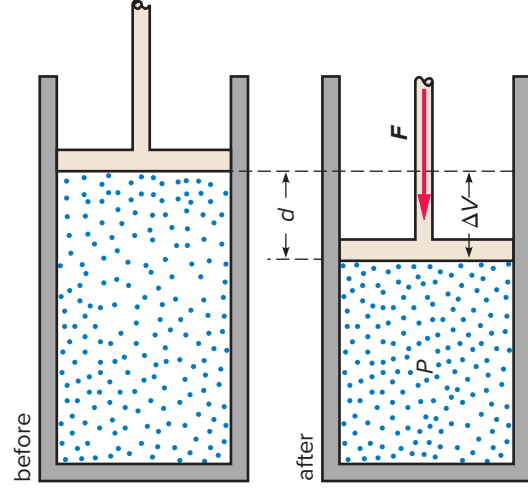
## 10.4 Gas Behavior and the First Law

What happens when we compress air in a cylinder? How does a hot-air balloon work? The behavior of gases in these and other situations can be investigated using the first law of thermodynamics, with the help of some additional facts about the nature of gases. Our atmosphere is another interesting system for exploring the laws of thermodynamics.

### What happens when we compress a gas?

Suppose a gas is contained in a cylinder with a movable piston, as in figure 10.15. If the piston is pushed inward by an external force, work is done by the piston *on* the gas in the cylinder. What effect does this have on the pressure or temperature of the gas?





**Figure 10.15** A movable piston compresses a gas in a cylinder. The magnitude of the work done is  $W = Fd = P\Delta V$ .

From the first law of thermodynamics, we know that doing work on a system adds energy to the system. By itself, work would increase the internal energy of the gas, but the change in internal energy also depends on the heat flow into or out of the gas. Knowing how much work is done on the gas provides only part of the picture.

From the definition of work (section 6.1) we know that the work done on the gas equals the force exerted by the piston times the distance the piston moves. Because pressure is the force per unit area, the force exerted on the piston by the gas equals the pressure of the gas times the area of the piston ( $F = PA$ ). If we move the piston without accelerating it, the net force acting on the piston is zero, and the external force applied to the piston equals the force exerted by the gas on the piston.

Putting these ideas together, the magnitude of the work done on the gas is the force times the distance  $d$  that the piston moves, or  $W = Fd = (PA)d$ . The motion of the piston produces a change in the volume of the gas, and this change in volume equals the area of the piston times the distance it moves,  $\Delta V = Ad$  (fig. 10.15). The work done by the gas in an expansion is therefore  $W = P\Delta V$ .

If the gas is being compressed, the volume of the gas is decreasing, and the change in volume  $\Delta V$  will be negative, indicating that the work done is also negative. Work is negative when it is done on the system. From the first law,  $\Delta U = Q - W$ , negative work increases the energy of the system, because the minus signs cancel. We do work on the gas in compressing it, and that work increases the internal energy of the gas. If the gas is expanding, positive work is done by the gas on its surroundings, and the internal energy of the gas decreases.

Compressing a gas causes its internal energy to increase in proportion to the change in volume of the gas, provided there is no heat flow across the boundaries of the container. What effect does this have on the gas? How does a change in internal energy affect the gas?

### How is internal energy related to temperature?

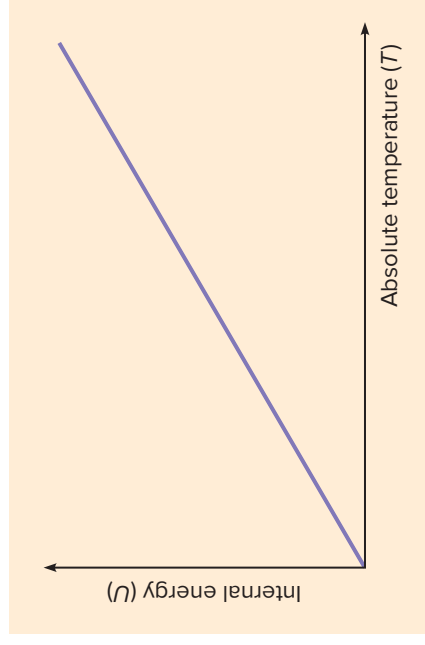
Many natural processes involving gases are **adiabatic**, meaning that no heat flows into or out of the gas during the process. If we compress a gas in a cylinder, for example, the compression can occur quickly enough that there is no time for a significant amount of heat to be transferred. The increase in internal energy is equal to the work done on the gas. What happens to the gas?

In general, internal energy is made up of both the kinetic and potential energies of the atoms and molecules in the system. In a gas, the internal energy is almost exclusively kinetic energy, because the molecules are so far apart (on average) that the potential energy of interaction between them is negligible. An **ideal gas** is one for which the forces between atoms (and the associated potential energy) are small enough to be completely ignored. This is a good approximation for gases in many situations.

For an ideal gas, the internal energy of the gas is exclusively kinetic energy. Increasing the internal energy increases the kinetic energy of the gas molecules. Absolute temperature is directly related to the average kinetic energy of the molecules of a system. If the internal energy of an ideal gas increases, the temperature also increases in direct proportion. A plot of internal energy as a function of absolute temperature for an ideal gas looks like the graph in figure 10.16.

The temperature of a gas will therefore increase in an adiabatic compression. According to the first law of thermodynamics, the internal energy of the gas increases by an amount equal to the work done on the gas. If we know the specific heat capacity and mass of the gas, we can calculate the increase in temperature from the energy increase.

The reverse is also true. If we allow the gas to expand against the piston, doing work on its surroundings, the internal energy of the gas decreases. The temperature of the gas decreases in an adiabatic expansion—this is how a refrigerator works. A pressurized gas is allowed to expand, lowering



**Figure 10.16** The internal energy is plotted as a function of absolute temperature for an ideal gas. The internal energy increases in direct proportion to the temperature.

its temperature. The cool gas then circulates through coils inside the refrigerator, removing heat from the contents of the refrigerator.

### How can we keep the temperature of a gas from changing?

Is it possible for the temperature of a gas to remain constant during a compression or expansion? In an **isothermal** process, the temperature does not change. (*Iso* means equal, and *thermal* refers to warmth or temperature.) Because of the direct relationship between temperature and internal energy in an ideal gas, the internal energy must be constant if there is no change in temperature. The change in internal energy,  $\Delta U$ , is zero for an isothermal process in an ideal gas.

If  $\Delta U$  is zero, the first law of thermodynamics ( $\Delta U = Q - W$ ) requires that  $W = Q$ . In other words, if an amount of heat  $Q$  is added to the gas, an equal amount of work  $W$  will be done by the gas on its surroundings if the temperature and the internal energy are to remain constant. It is possible to add heat to a gas without changing its temperature, as long as the gas does an equal amount of work on its surroundings by expanding. (This is *not* an adiabatic process, because heat is flowing into the system!)

Here again, the reverse is also true. If we compress a gas while holding the temperature constant, heat is removed from the gas, according to the first law of thermodynamics. For the internal energy and the temperature to remain constant, energy added to the gas in the form of work must result in an equal amount of energy in the form of heat being removed. Isothermal compressions and expansions are important processes in heat engines, which we will consider in chapter 11.

### What happens to the gas in a hot-air balloon?

When the gas is heated in a hot-air balloon (fig. 10.17), the pressure, not the temperature, remains constant. The pressure of the gas inside the balloon cannot be significantly larger than that of the surrounding atmosphere. When pressure remains constant in a process, it is called **isobaric** (*baric* refers to pressure). The internal energy increases as the gas is heated, and so does the temperature. The gas also expands in this process, however, which removes some internal energy.

The gas expands in the isobaric heating process because of another property of ideal gases discovered near the beginning of the nineteenth century. A series of experiments showed that the pressure, volume, and absolute temperature of an ideal gas are related by the equation  $PV = NkT$ , where  $N$  is the number of molecules in the gas and  $k$  is a constant of nature called *Boltzmann's constant*. (Ludwig Boltzmann [1844–1906] was an Austrian physicist who developed a statistical theory of gas behavior.) This equation is called the **equation of state** of an ideal gas. It is also often referred to as the Ideal Gas Law. Example box 10.3 uses this equation of state.

The temperature  $T$  used in the equation of state must be the absolute temperature. Recall that the concept of



**Figure 10.17** Heat is added to the air in a hot-air balloon by the propane burner above the gondola. The heated air expands, making it less dense than the surrounding air.

*Open Door/Alamy Stock Photo*

absolute temperature originally arose in the study of the behavior of gases (see section 10.1). The equation of state combines Boyle's law (section 9.2) with the effect of temperature on pressure discussed in section 10.1. The equation of state shows that if the temperature increases while the pressure and number of molecules are held constant, the volume of the gas also must increase. In other words, the gas expands. Likewise, if the gas expands at constant pressure, the temperature must increase.

For an isobaric expansion, the first law of thermodynamics indicates that the heat added to the gas must be greater than the amount of work done by the gas in expanding. The internal energy,  $U$ , increases when the temperature increases. Because  $\Delta U = Q - W$ ,  $Q$  must be larger than  $W$  (which is positive, because the gas is expanding) for the internal energy to increase. The first law of thermodynamics and the equation of state for an ideal gas can then be used to compute how much heat must be added to the system to produce a given amount of expansion.

## Example Box 10.3

### Sample Exercise: Using the Ideal Gas Law

Suppose the pressure of an ideal gas mixture remains constant, and the volume of the mixture is decreased from 4 liters to 1 liter. If the initial temperature is 600 K, what is the final temperature?

This question can be answered using the Ideal Gas Law:  $PV = NkT$ . Because we assume no gas escapes the container, we assume  $N$ , the number of molecules of gas, remains constant. Boltzmann's constant also does not change. The Ideal Gas Law,  $PV = NkT$ , can be rewritten as  $V/T = Nk/P =$  a constant.

$$\begin{aligned} V_{\text{initial}} &= 4 \text{ liters} \\ V_{\text{final}} &= 1 \text{ liter} \\ T_{\text{initial}} &= 600 \text{ K} \\ T_{\text{final}} &= ? \end{aligned}$$

$$\frac{V_{\text{initial}}}{T_{\text{initial}}} = \frac{V_{\text{final}}}{T_{\text{final}}}$$

Cross multiplying:

$$\frac{T_{\text{final}}}{T_{\text{initial}}} = \frac{V_{\text{final}}}{V_{\text{initial}}}$$

$$\frac{T_{\text{final}}}{T_{\text{initial}}} = \frac{1/}{4/} = \frac{1}{4}$$

Therefore,

$$T_{\text{final}} = \frac{1}{4} T_{\text{initial}}$$

$$T_{\text{final}} = \frac{1}{4} (600 \text{ K}) = 150 \text{ K}$$

Notice that even though you may not know how many molecules of gas there are ( $N$ ) or the value of Boltzmann's constant,  $k$  (which you could look up), you can still use the Ideal Gas Law to discover how the pressure, temperature, and volume change relative to one another.

Because the gas inside the balloon has expanded, the same number of molecules now occupy a larger volume, and the density of the gas has decreased. In other words, the balloon rises, because the density of the gas inside the balloon is less than the density of the air outside the balloon. The buoyant force acting on the balloon is described by Archimedes' principle (section 9.3).

The same phenomenon occurs on a much larger scale in the atmosphere. A warm air mass will rise compared to cooler air masses for the same reason a hot-air balloon rises. Air heated near the ground on a warm summer day expands, becomes less dense, and rises in the atmosphere. Rising air carries water vapor that provides the moisture for the formation of clouds at higher elevations. The rising columns of warm air also create air turbulence, which can become a problem for aircraft. These *thermals* are a real boon, however, to hang-glider enthusiasts and soaring eagles.

The behavior of gases and the implications of the first law of thermodynamics play important roles in our

understanding of weather phenomena. Latent heat is involved in the evaporation and condensation of water, as well as in the formation of ice crystals in snow or sleet. The source of energy for all of these processes is the sun: Surface water and the atmosphere of the Earth are a huge engine driven by the sun.

The first law of thermodynamics explains many processes involving gases. The absolute temperature of a gas is directly related to the internal energy of the gas. In the case of an ideal gas, the internal energy is the kinetic energy of the gas molecules. The amount of heat added and the work done by the gas determine its temperature, yielding different results for adiabatic, isothermal, and isobaric processes. The first law, together with the equation of state, can be used to predict the behavior of gases in heat engines, hot-air balloons, and air masses in the atmosphere.

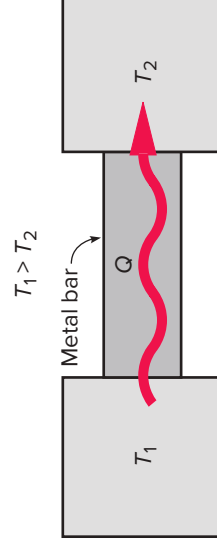
## 10.5 The Flow of Heat

In most areas of the world, we need to heat our homes and buildings in the winter. We warm our houses by burning wood or fossil fuels, such as coal, oil, or natural gas, in a furnace or by electric heating. We pay for the fuel we use and thus have an incentive to keep the heat it generates from escaping. How does heat flow away from a house or any other warm object? What mechanisms are involved, and how can we lessen the loss of heat by our awareness of these mechanisms?

Conduction, convection, and radiation are the three basic means of heat flow. All three are important in heat loss (or gain) from a house. An understanding of these mechanisms can help you achieve comfort while saving fuel in your house, residence-hall room, or workplace.

### Heat flow by conduction

In **conduction**, heat flows *through* a material when objects at different temperatures are placed in contact with each other (fig. 10.18). Heat flows directly from the hotter body



**Figure 10.18** In thermal conduction, energy flows through a material when there is a temperature difference across the material.



**Figure 10.19** When a metal block and a wooden block, both at room temperature, are picked up, the metal block feels cooler.  
James Ballard/McGraw-Hill Education

to the cooler body at a rate that depends on the temperature difference between the bodies and a property of the materials called the **thermal conductivity**. Some materials have much larger thermal conductivities than others. Metals, for example, are much better heat conductors than wood or plastic.

Imagine that you pick up a block of metal in one hand and a block of wood in the other (fig. 10.19). The two blocks are at room temperature, but your body is typically 10 to 15 Celsius degrees warmer than room temperature, so heat will flow from your hands to the blocks. The metal block, however, will feel colder than the wood block. Because the two blocks are initially at the same temperature, the difference lies in the thermal conductivity, not in the temperature, of the two materials. Metal conducts heat more readily than wood does, so the heat flows more rapidly from your hand into the metal than into the wood. Because contact with the metal cools your hand more rapidly than contact with the wood, the metal block feels colder.

Heat flow is a flow of energy, the actual transfer of kinetic energy of atoms and electrons. Because of the higher temperature of your hands, the average kinetic energy of the atoms in your hands is larger than the average kinetic energy of the atoms in the blocks. As the atoms bump into one another, kinetic energy is transferred, and the average kinetic energy of the atoms in the blocks increases at the expense of the atoms in your hands. Free electrons in metals play an important role in this process: Metals are good conductors of both heat and electrical charge.

In discussing home insulation, we often use the concept of thermal resistance, or  $R$  values, to compare the effectiveness of various materials as insulators. The greater the conductivity, the lower the  $R$  value, because good thermal conductors are poor thermal insulators. The  $R$  value, in fact, relates both to the thickness of the material and to its thermal conductivity. The insulating effect of a material increases as its thickness increases, so  $R$  values increase with the thickness of the material.

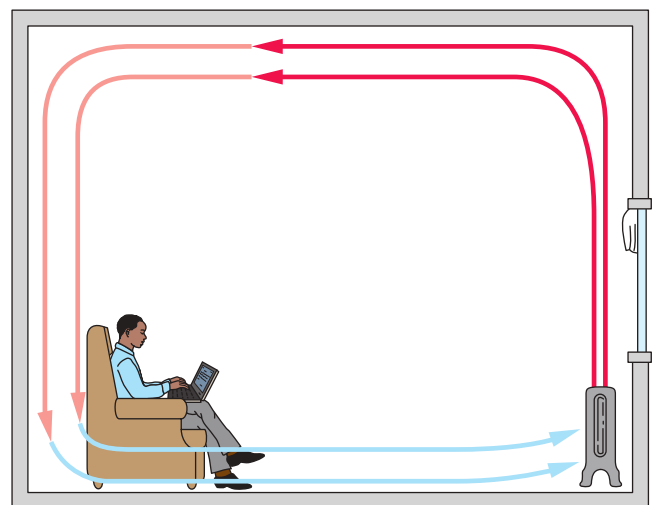
Still air is a good thermal insulator. Porous materials with trapped pockets of air, like rock wool or fiberglass insulation, make excellent insulators and have high  $R$  values. Their low thermal conductivities result from the air pockets trapped in these materials rather than from the materials themselves. When we use such materials to insulate the walls, ceilings, and floors of a dwelling, we reduce their ability to conduct heat and lessen heat loss from the house.

### What is convection?

If we heat a volume of air, then move the air by blowers or natural flow, we transfer heat by convection. In heating a house, we often move air, water, or steam through pipes or ducts to carry heat from a central furnace to different rooms.

**Convection** transfers heat by the *motion of a fluid* containing thermal energy. Recall from the beginning of chapter 9 that both gases and liquids are fluids.

Convection, therefore, is the main way of heating a house. Warm air is less dense than cooler air, so it tends to rise from radiators or baseboard heaters toward the ceiling. As it does, the warm air sets up air currents within the room that distribute energy around the room. Warm air rises along the wall containing the heat source, and cooler air falls along the opposite wall (fig. 10.20). This is called natural convection; the use of fans would be forced convection.



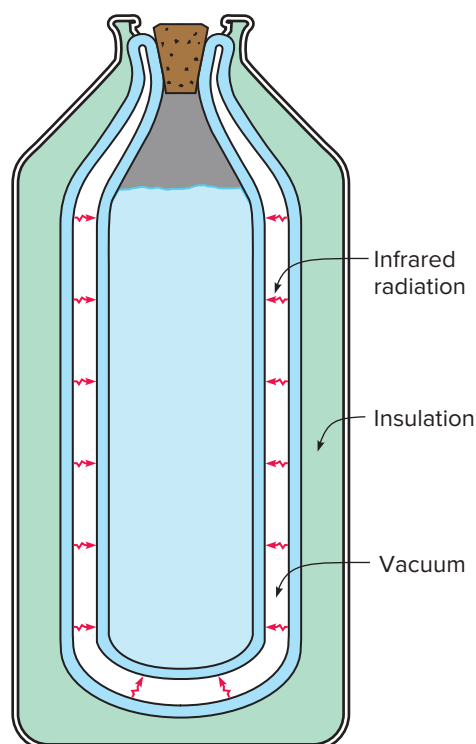
**Figure 10.20** In convection, thermal energy is transferred by the motion of a heated fluid. In a room, this occurs when heated air flows from a radiator or heater duct.

Convection is also involved in heat loss from buildings. When warm air leaks out of a building or cooler air leaks in from outside, we say we are losing heat to *infiltration*, a form of convection. Infiltration can be prevented, to some extent, by weather-stripping doors and windows and by sealing other cracks or holes. It is not desirable, however, to eliminate infiltration completely. A turnover of the air in a house is needed to keep the air fresh and free of odors.

### What is radiation, and how does it transfer heat?

**Radiation** involves the flow of energy by *electromagnetic waves*. Wave motion and electromagnetic waves are discussed in chapters 15 and 16. The electromagnetic waves involved in the transfer of heat lie primarily in the infrared portion of the electromagnetic wave spectrum. Infrared wavelengths are shorter than those of radio waves but longer than the wavelengths of visible light. (See fig. 16.5.)

While conduction requires a medium to travel through, and convection a medium to be carried along with, radiation can take place across a vacuum, such as the evacuated barrier in a thermos bottle (fig. 10.21). The radiation is reduced



**Figure 10.21** Radiation is the only mechanism that can carry thermal energy across the evacuated space in a thermos bottle. Silvering the walls reduces the flow of radiation.

to a minimum by silvering the facing walls of the evacuated space. Silvering causes the electromagnetic waves to be reflected rather than absorbed and reduces the energy flow into or out of the container.

The same principle is involved in the use of foil-backed insulation in housing construction. Some of the heat flow across the dead-air space within a wall is due to radiation and some to conduction through the air. Using foil-backed insulation reduces heat flow from radiation. Thin sheets of foil-backed insulation may have  $R$  values equal to those of thicker sheets of insulation without the foil backing.

Radiation is also involved in the loss of energy from roofs or from road surfaces to the dark (and cold) night sky. Blacktopped road surfaces, in particular, and black surfaces, in general, are effective radiators of electromagnetic waves. The road surface radiates energy to the sky, cooling the surface more rapidly than the surrounding air. Even when the air temperature is still above freezing, the surface of a blacktopped road can drop below the freezing point, creating icy conditions.

Good absorbers of electromagnetic radiation are also good emitters: Black materials both absorb more solar energy in the summer and lose more heat in the winter. A black roof may look nice, but it is not the best color for energy conservation. A lighter color is more effective in keeping your home both cool in the summer and warm in the winter.

Knowledge of the basic mechanisms of heat transfer is useful in designing a house. Conduction, convection, and radiation are all important in understanding how heat flows into and out of a house, as well as how it circulates inside the house. Large windows produce high heat loss, even when double-pane windows are used. If the window is on the south side of the house, however, this heat loss may be partially offset by the heat gain by radiation from the sun. Heat-flow mechanisms are also important in understanding how to make the best use of solar energy, discussed in everyday phenomenon box 10.2.

The flow of heat can occur by three distinct means—conduction, convection, and radiation. In conduction, energy is transferred through a material; some materials are better thermal conductors than others. Convection involves the transfer of heat by the flow of a fluid containing thermal energy. Radiation is the flow of energy through electromagnetic waves. All three of these processes are important in any application of the first law of thermodynamics, because the flow of heat is one way the internal energy of a system can change.

## Everyday Phenomenon

## Box 10.2

## Solar Collectors, Greenhouses, and Global Warming

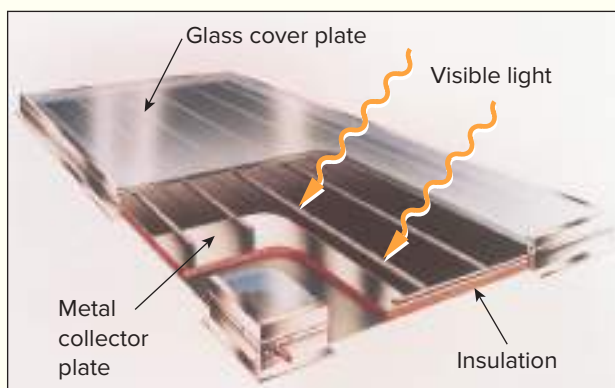
**The Situation.** Flat-plate, water-flow solar collectors are still in use for heating water for houses and similar uses. (Photovoltaic collectors are now used extensively for electric power.) The flat-plate collector consists of a metal plate with water-carrying tubes bonded to its surface. The plate and tubes are painted black and are held in a frame insulated below the plate, with a glass or transparent plastic cover on top. How does the flat-plate collector work? What heat-flow processes are involved? How is the flat-plate collector related to climate change?

**The Analysis.** The flat-plate collector receives energy from the sun as electromagnetic radiation, which is the only type of heat flow that can cross the vacuum of space. Much of the electromagnetic waves coming from the sun are in the visible portion of the electromagnetic spectrum to which our eyes are sensitive. These waves pass easily through the transparent cover of the collector.

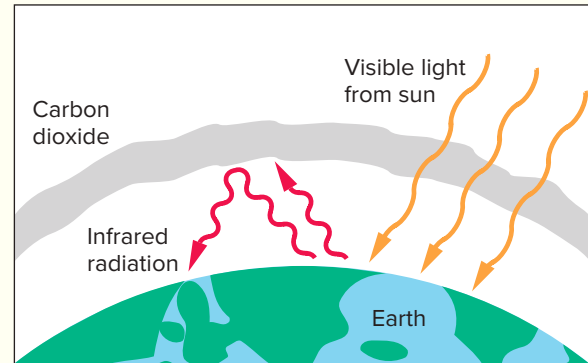
The black surface of the collector plate absorbs most of the visible light coming in, reflecting very little. The absorbed light energy raises the temperature of the plate, and the water flowing through the tubes bonded to the plate is then heated by conduction. The insulation beneath the plate reduces heat flow to the surroundings.

Because it is warm, the metal plate will radiate heat in the form of electromagnetic waves in the far infrared portion of the electromagnetic spectrum. However, the glass or plastic cover is opaque to infrared radiation, so the waves cannot pass through the cover. The cover also prevents heat flow from escaping by convection. The collector is an energy trap.

The one-way transmission of radiation of light entering the visible part of the spectrum, but not escaping in the infrared wavelengths of heated objects inside, is called the **greenhouse effect**. Greenhouses trap energy from the sun in cool weather keeping the plants in a warm environment. It is the same effect



The black-surfaced metal collecting plate of a flat-plate solar collector is insulated below and covered with a glass or transparent plastic plate above.



Carbon dioxide and other gases in the atmosphere of the Earth play the same role as the cover plate on a solar collector. Visible light passes through, but infrared radiation does not.

that causes your car to get hot on a sunny day when the windows are closed.

In the case of **global warming**, the Earth resembles an enormous greenhouse. Carbon dioxide and some other gases in the atmosphere allow visible light to come in from the sun but do not let through some of the infrared waves emitted by warmed plants and other features on the Earth. Carbon dioxide is emitted by any carbon-based fuel that is burned to provide energy, which includes coal, oil, natural gas, and wood. Except for wood, these energy sources are called fossil fuels.

Our heavy use of fossil fuels in the last one hundred years or so has slowly increased the amount of carbon dioxide in the atmosphere. This increase, in turn, has slowly increased the average temperature of the Earth. Although the modeling of the Earth's average temperature is an extremely complex problem, involving ocean currents and many other factors, research seems to show that burning of fossil fuels is a major cause of global warming. This is happening in a very short time in geologic terms compared to the millions of years that were required to create the fossil fuels. (See fig. 1.2 in chapter 1.)

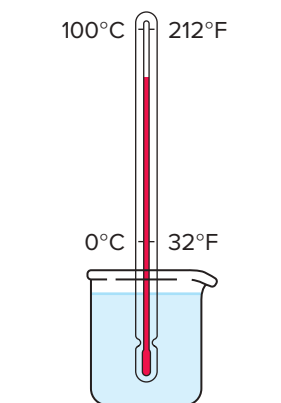
Another major factor in global temperatures is the effect of plants. Plants absorb carbon dioxide from the air as they grow, and they release some of it when they die or burn, but some is buried in the ground by covering leaves and dirt. As forests and other plants are lost by fires and the removal of trees for buildings and roads, the positive effect of plants is reduced.

An obvious partial solution to the increase in greenhouse gases is to reduce the worldwide use of fossil fuels. Energy conservation can help, but all of these efforts cannot happen overnight. Research plays a big role in developing energy sources that do not need fossil fuels. These might include nuclear energy as well as renewable sources such as wind, solar, and ocean waves (see everyday phenomenon box 15.1 in chapter 15).

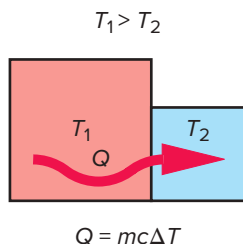
## Summary

Heat, which plays an important role in the first law of thermodynamics, is the focus of this chapter. We used the first law of thermodynamics to explain changes in the temperature or phase of a substance, as well as the behavior of an ideal gas. The distinction between the concepts of heat and temperature is critical.

**1 Temperature and its measurement.** Temperature scales have been devised to provide a consistent means of describing how hot or cold an object is. When objects are at the same temperature, no heat flows between them, and the physical properties remain constant. The idea of an absolute zero of temperature emerged from studies of gas behavior.

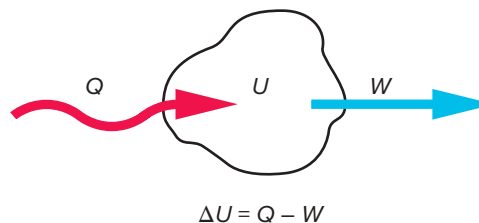


**2 Heat and specific heat capacity.** The energy that flows between objects because they are at different temperatures is called *heat*. The amount of heat required to cause a 1° change in temperature to one unit of mass is called the *specific heat capacity*. Latent heat is the amount of heat per unit mass required to change the phase of a substance without changing the temperature.

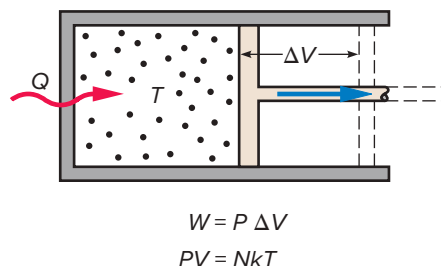


**3 Joule's experiment and the first law of thermodynamics.** The first law of thermodynamics states that the internal energy of a substance or system can be increased either by adding heat or by doing work on the system. Increasing the internal energy increases the potential and kinetic energies of the atoms and molecules making up the system, and it may show up as an

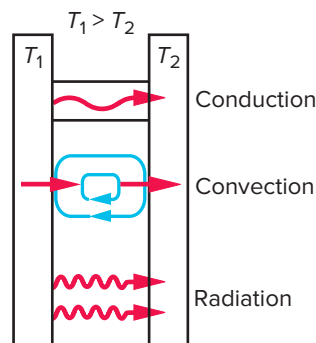
increase in temperature, as a change of phase, or as changes in other properties of the system.



**4 Gas behavior and the first law.** The internal energy of an ideal gas equals the kinetic energy of the gas molecules. It varies directly with the absolute temperature of the gas. Work done by the gas is proportional to its change in volume, so the first law can be used to predict how the temperature or pressure will change when work is done or heat is added.



**5 The flow of heat.** There are three basic mechanisms of heat flow from one system to another. Conduction is the direct flow of heat through materials. Convection is the flow of heat carried by a moving fluid. Radiation is the flow of heat by electromagnetic waves.



The study hints in Connect give a good summary of the chapter, which might help reinforce some of these hot topics.

## Key Terms

Thermodynamics, 193  
 Thermal equilibrium, 194  
 Zeroth law of thermodynamics, 194  
 Absolute zero, 196

Absolute temperature, 196  
 Heat, 197  
 Specific heat capacity, 197  
 Temperature, 198

Change of phase, 198  
 Latent heat, 199  
 First law of thermodynamics, 202  
 Internal energy, 202

Adiabatic, 204  
 Ideal gas, 204  
 Isothermal, 205  
 Isobaric, 205

Equation of state, 205  
 Conduction, 206  
 Thermal conductivity, 207  
 Convection, 207

Radiation, 208  
 Greenhouse effect, 209  
 Global warming, 209

## Conceptual Questions

\* = more open-ended questions, requiring lengthier responses, suitable for group discussion

**Q** = sample responses are available in appendix D

**Q** = sample responses are available in Connect

- Q1. Is an object that has a temperature of  $0^{\circ}\text{C}$  hotter than, colder than, or at the same temperature as one that has a temperature of  $0^{\circ}\text{F}$ ? Explain.
- Q2. Which spans a greater range in temperature, a change in temperature of 10 Fahrenheit degrees or a change of 10 Celsius degrees? Explain.
- Q3.** The volume of a gas held at constant pressure increases in a predictable way when its temperature increases. Could such a system be used as a thermometer? Explain.
- \*Q4. We sometimes attempt to determine whether another person has a fever by placing a hand on his or her forehead. Is this a reliable procedure? What assumptions do we make in this process?
- Q5. Is it possible for a temperature to be lower than  $0^{\circ}\text{C}$ ? Explain.
- Q6.** Is it possible for a temperature to be lower than 0 K on the Kelvin temperature scale? Explain.
- Q7. Is an object with a temperature of 273.2 K hotter than, colder than, or at the same temperature as an object with a temperature of  $0^{\circ}\text{C}$ ? Explain.
- Q8. Two objects at different temperatures are placed in contact with each other but are insulated from the surroundings. Will the temperature of either object change? Explain.
- Q9.** Is it possible for the final temperature of the objects in question 8 to be greater than the initial temperatures of both objects? Explain.
- Q10. Two objects of the same mass, but made of different materials, are initially at the same temperature. Equal amounts of heat are added to each object. Will the final temperature of the two objects necessarily be the same? Explain.
- Q11. Two cities, one near a large lake and the other in the desert, both reach the same high temperature during the day. Which city, if either, would you expect to cool down more rapidly once the sun has set? Explain.
- Q12.** Is it possible to add heat to a substance without changing its temperature? Explain.
- Q13. What happens if we add heat to water that is at the temperature of  $100^{\circ}\text{C}$ ? Does the temperature change? Explain.
- Q14. What happens if we remove heat from water at  $0^{\circ}\text{C}$ ? Does the temperature change? Explain.
- Q15.** What does it mean for a liquid to be supercooled? (See everyday phenomenon box 10.1.)
- Q16. When the liquid in a heat pack freezes, does the heat pack get colder? Explain. (See everyday phenomenon box 10.1.)
- Q17. Would a phase-change material (PCM) be useful in a thermal-electric solar power plant? Explain. (See everyday phenomenon box 10.1.)
- Q18.** Is it possible to change the temperature of a glass of water by stirring the water, even though the glass is insulated from its surroundings? Explain.
- Q19. A hammer is used to pound a piece of soft metal into a new shape. If the metal is thermally insulated from its surroundings, will its temperature change due to the pounding? Explain.
- Q20. Which represents the greater amount of energy, 1 J or 1 cal? Explain.
- \***Q21.** Suppose the internal energy of a system has been increased, resulting in an increase in the temperature of the system. Is it possible to tell from the final state of the system whether the change in internal energy was due to the addition of heat or of work to the system? Explain.
- Q22. Is it possible for the internal energy of a system to be greater than the kinetic energy of the molecules and atoms making up the system? Explain.
- \*Q23. Based on his experiments, Joule proposed that the water in a pool at the bottom of a waterfall should have a higher temperature than that at the top. Why might this be so? Explain.
- Q24.** An ideal gas is compressed without allowing any heat to flow into or out of the gas. Will the temperature of the gas increase, decrease, or remain the same in this process? Explain.
- Q25. Is it possible to decrease the temperature of a gas without removing any heat from the gas? Explain.
- Q26. Heat is added to an ideal gas, and the gas expands in the process. Is it possible for the temperature to remain constant in this situation? Explain.
- Q27.** Heat is added to an ideal gas maintained at constant volume. Is it possible for the temperature of the gas to remain constant in this process? Explain.
- Q28. Heat is added to a hot-air balloon, causing the air to expand. Will this increased volume of air cause the balloon to fall? Explain.
- \*Q29. Heat is added to ice, causing the ice to melt but producing no change in temperature. Because water expands when it freezes into ice, the volume of the water obtained from melting the ice is less than the initial volume of ice. Does the internal energy of the ice-water system change in this process? Explain.



- Q30.** A block of wood and a block of metal have been sitting on a table for a long time. The block of metal feels colder to the touch than the block of wood. Does this mean that the metal is actually at a lower temperature than the wood? Explain.
- Q31. Heat is sometimes lost from a house through cracks around windows and doors. What mechanism of heat transfer (conduction, convection, or radiation) is involved? Explain.
- Q32. Is it possible for water on the surface of a road to freeze even if the temperature of the air just above the road is above 0°C? Explain.
- Q33.** What heat-transfer mechanisms (conduction, convection, or radiation) are involved when heat flows through a glass windowpane? Explain.
- Q34. Is it possible for heat to flow across a vacuum? Explain.
- Q35. How do we get heat from the sun through the freezing empty space between the sun and Earth?
- Q36.** What property does glass share with carbon dioxide gas that makes them both effective at producing the greenhouse effect? Explain.
- Q37. What mechanism of heat flow (conduction, convection, or radiation) is involved in transporting useful thermal energy away from a flat-plate solar collector? Explain. (See everyday phenomenon box 10.2.)
- Q38. Will a solar power plant (one that generates electricity from solar energy) have the same tendency to increase the greenhouse effect in the atmosphere as a coal-fired power plant? Explain. (See everyday phenomenon box 10.2.)

## Exercises

For the exercises in this chapter, use the value of  $c = 1.0 \text{ cal/g}^\circ\text{C}$  for the specific heat of water. The conversion between calories and joules is  $4.19 \text{ J} = 1 \text{ cal}$ .

- E1. An object has a temperature of 22°C.  
a. What is its temperature in degrees Fahrenheit?  
b. What is this temperature on the absolute (Kelvin) scale?
- E2. The temperature on a winter day is 20°F. What is the temperature in degrees Celsius?
- E3. The temperature on a very warm summer day is 110°F. What is the temperature  
a. In degrees Celsius?  
b. On the absolute (Kelvin) scale?
- E4. The temperature of a warm beaker of water is 300.2 K. What is this temperature  
a. In degrees Celsius?  
b. In degrees Fahrenheit?
- E5. On a warm summer day, the temperature changes from 18°C in the morning to 30°C in the late afternoon.  
a. What is the change in temperature from the morning to the afternoon in degrees Celsius?  
b. What is the initial temperature in the morning in Fahrenheit?  
c. What is the final temperature in the afternoon in Fahrenheit?  
d. What is the change in temperature from the morning to the afternoon in degrees Fahrenheit?  
e. Notice that you cannot calculate this  $\Delta T$  in Fahrenheit by converting the  $\Delta T$  in degrees Celsius using the conversion between Celsius and Fahrenheit. Why not? (Fig. 10.4 might help you figure it out.)
- E6. How much heat is required to raise the temperature of 90 g of water from 12°C to 88°C?
- E7. How much heat must be removed from a 300-g block of aluminum to lower its temperature from 160°C to 40°C? The specific heat capacity of aluminum is  $0.215 \text{ cal/g}\cdot^\circ\text{C}$ .
- E8. How much heat must be added to 120 g of ice at 0°C to melt the ice completely?
- E9. If 900 cal of heat are added to 75 g of water initially at a temperature of 18°C, what is the final temperature of the water?
- E10. How much heat must be added to 60 g of water at an initial temperature of 22°C to  
a. Heat it to the boiling point?  
b. Completely convert the 100°C water to steam?
- E11. If 300 cal of heat are added to a system, how much energy has been added in joules?
- E12. If 1400 J of heat are added to 90 g of water initially at 18°C,  
a. How much energy is this in calories?  
b. What is the final temperature of the water?
- E13. While a gas does 825 J of work on its surroundings, 1200 J of heat are added to the gas.  
a. Ignoring the heat added for the moment, if a gas does 825 J of work on its surroundings, does that cause an increase or decrease in the internal energy of the gas?  
b. Now, ignoring the work done by the gas for the moment, if 1200 J of heat are added to the gas, does that cause an increase or decrease in the internal energy of the gas?  
c. Taking both these factors into account, does the internal energy of the gas increase or decrease, and by how much?
- E14. The volume of an ideal gas is increased from  $0.4 \text{ m}^3$  to  $2.5 \text{ m}^3$  while maintaining a constant pressure of 3600 Pa ( $1 \text{ Pa} = 1 \text{ N/m}^2$ ). How much work is done by the gas in this expansion?
- E15. If the initial temperature in exercise E14 is 480 K, what is the final temperature?
- E16. Work of 2200 J is done on an ideal gas, but the internal energy increases by only 1500 J. What are the amount and direction of heat flow into or out of the system?

- E17. Four hundred calories of heat are added to a gas. In addition, the gas expands and does 400 joules of work on its surroundings.
- How many joules do the 400 calories represent?
  - What is the change in internal energy of the gas in joules?
  - What is the change in internal energy of the gas in calories?
  - Will this cause an increase or decrease in the temperature of the gas?
- E18. Work of 1800 J is done by stirring a perfectly insulated beaker containing 75 g of water.
- What is  $Q$  (heat added or removed) for this process?
  - What is the change in the internal energy of the system?
  - What is the change in the temperature of the water?

## Synthesis Problems

For the synthesis problems in this chapter, use the value of  $c = 1.0 \text{ cal/g } ^\circ\text{C}$  for the specific heat of water. The conversion between calories and joules is  $4.19 \text{ J} = 1 \text{ cal}$ .

- SP1. Heat is added to an object initially at  $24^\circ\text{C}$ , increasing its temperature to  $83^\circ\text{C}$ . (Hint: Review exercise E5 before doing this problem.)
- What is the temperature change of the object in Fahrenheit degrees?
  - What is the temperature change of the object in kelvins?
  - Is there any difference in the numerical value of a heat capacity expressed in  $\text{cal/g}\cdot^\circ\text{C}$  from one expressed in  $\text{cal/g}\cdot\text{K}$ ? Explain.
- SP2. A student constructs a thermometer and invents her own temperature scale with the ice point of water at  $0^\circ\text{S}$  (S for student) and the boiling point of water at  $75^\circ\text{S}$ . She measures the temperature of a beaker of water with her thermometer and finds it to be  $18^\circ\text{S}$ .
- What is the temperature of the water in degrees Celsius?
  - What is the temperature of the water in degrees Fahrenheit?
  - What is the temperature of the water in kelvins?
  - Is the temperature range spanned by 1 Student degree larger or smaller than the range spanned by 1 Celsius degree? Explain.
- SP3. The initial temperature of 140 g of ice is  $-22^\circ\text{C}$ . The specific heat capacity of ice is  $0.5 \text{ cal/g}\cdot^\circ\text{C}$ , and water's is  $1 \text{ cal/g}\cdot^\circ\text{C}$ . The latent heat of fusion of water is  $80 \text{ cal/g}$ .
- How much heat is required to raise the ice to  $0^\circ\text{C}$ ?
  - How much additional heat is required to completely melt the ice after it has reached  $0^\circ\text{C}$ ?
  - How much additional heat is required to heat the water (obtained by melting the ice) to  $27^\circ\text{C}$ ?
  - What is the total heat that must be added to convert the 140 g of ice at  $-22^\circ\text{C}$  to water at  $+27^\circ\text{C}$ ?
  - Examine your answers to parts a, b, and c. Which takes the most energy: heating ice to the melting point, melting the ice, or heating the cold water to the final temperature?
  - Can we find this total heat simply by computing how much heat is required to melt the ice and adding the amount of heat required to raise the temperature of 140 g of water by  $49^\circ\text{C}$ ? Explain.
- SP4. A 170-g quantity of a certain metal, initially at  $125^\circ\text{C}$ , is dropped into an insulated beaker containing 84 g of water at  $16^\circ\text{C}$ . The final temperature of the metal and water in the beaker is measured as  $39^\circ\text{C}$ . Assume that the heat capacity of the beaker can be ignored.
- How much heat has been transferred from the metal to the water?
  - Given the temperature change and mass of the metal, what is the specific heat capacity of the metal?
  - If the final temperature of the water and this metal is  $53^\circ\text{C}$  instead of  $39^\circ\text{C}$ , what quantity of this metal (initially at  $125^\circ\text{C}$ ) was dropped into the insulated beaker?
- SP5. A beaker containing 600 g of water has 2300 J of work done on it by stirring and 400 cal of heat added to it from a hot plate.
- What is the change in the internal energy of the water in joules?
  - What is the change in the internal energy of the water in calories?
  - What is the temperature change of the water?
  - Would your answers to the first three parts differ if there had been 200 J of work done and 1200 cal of heat added? Explain.
- SP6. Suppose the pressure of an ideal gas mixture remains constant at 1800 Pa ( $1 \text{ Pa} = 1 \text{ N/m}^2$ ) and the temperature is increased from 220 K to 1100 K.
- If the original volume of the gas was  $0.17 \text{ m}^3$ , what is the final volume? (See example box 10.3.)
  - What is the change in volume  $\Delta V$  for this process?
  - How much work does the gas do on the surroundings during the expansion?
  - If the initial volume was  $0.24 \text{ m}^3$  and the same temperature change occurred, would the work done be the same as in the first case? Show by repeating the steps of the first three parts.
  - Is the same amount of gas involved in these two situations? Explain.

## Home Experiments and Observations

- HE1. Look around your home to see what kinds of thermometers you can find. Indoor, outdoor, clinical, or cooking thermometers can be found in most homes. For each thermometer, note these things:
- What temperature scales are used?
  - What is the temperature range of each thermometer?
  - What is the smallest temperature change that can be read on each thermometer?
  - What changing physical property is used to indicate change in temperature for each thermometer?
- HE2. Partially fill two Styrofoam cups with equal amounts of cold water, and drop equal amounts of ice into each cup to obtain a mixture of ice and water.
- Stir the water and ice mixture in one of the cups vigorously with a nonmetallic stirrer until all of the ice has been melted. Note the time it takes to melt the ice.
  - Set the second cup aside and observe it every 10 minutes or so until all the ice has melted. Note the time it takes for the ice to melt.
  - How do the times compare? Where is the energy coming from to melt the ice in each cup?
- HE3. Fill a Styrofoam cup with very hot water (or coffee). Gather objects made of different materials, such as a metal spoon, a wooden pencil, a plastic pen, and a glass rod. Put one end of each object into the water and answer the following questions.
- How close to the surface of the water do you have to hold the object for it to feel noticeably warm to the touch?
  - From your observations, which material do you judge to be the best conductor of heat? Which is the worst? Can you rank the materials according to their ability to conduct heat?
- HE4. Conduct an energy survey of your residence-hall room or other similar living space. Answer the following questions.
- What is the heat source (or sources) for the room and how does this heat flow into the room? What heat-flow mechanisms are involved?
  - How is heat lost from the room? What heat-flow mechanisms are involved?
  - What could be done to reduce heat loss or to otherwise improve the energy efficiency of the room?



Zoonar GmbH/Alamy Stock Photo

## Heat Engines and the Second Law of Thermodynamics

### Chapter Overview

After a discussion of heat engines in this chapter, we explore the second law of thermodynamics. The second law is central to understanding the efficiency of heat engines. Using both the first and the second laws of thermodynamics, we then consider the use of energy resources in today's global economy. These issues have fundamental significance to the quality of our environment, as well as to the health of our economy. The laws of thermodynamics are critical to making intelligent choices about energy policy.

### Chapter Outline

- 1 Heat engines.** What is a heat engine? What does the first law of thermodynamics tell us about how heat engines work?
- 2 The second law of thermodynamics.** How would an ideal heat engine operate if we could build one? How is the concept of an ideal engine related to the second law of thermodynamics—what does the second law say and mean?
- 3 Refrigerators, heat pumps, and entropy.** What does a refrigerator or heat pump do? What is entropy? How is it related to limitations on the use of heat energy?
- 4 Thermal power plants and energy resources.** How can we generate power efficiently? What are the implications of the second law of thermodynamics in our use of energy resources, such as fossil fuels and solar energy?
- 5 Perpetual motion and energy frauds.** Is perpetual motion possible, according to the laws of thermodynamics? How can we judge the claims of inventors?

Many of us spend a good portion of our lives driving or riding in automobiles. We talk about how many miles per gallon we get or discuss the merits of different kinds of engines. We regularly drive into gas stations to buy unleaded gasoline, and we generally have a good idea of what this fuel costs at different places (fig. 11.1).

How many of us really understand what is going on inside that engine, though? As we turn the ignition switch and depress the gas pedal, the engine roars into action, consumes fuel, and powers the car at our command, without requiring us to have a detailed knowledge of its principles of operation. Ignorance may be bliss—until something goes wrong—and then some understanding of the engine may be useful. What does an automobile engine do, and how does it work?

The internal combustion engine used in most modern automobiles is a **heat engine**. The science of thermodynamics arose in an attempt to better understand the principles of operation of steam engines, the first practical versions of heat engines. Building more efficient engines was the primary objective. Although steam engines are usually external combustion engines, whose fuel is burned outside of the engine rather than inside, the basic principles of operation of steam engines and automobile engines are the same.



**Figure 11.1** Filling up the family chariot. How does the engine use this fuel to produce motion?

*Kaspars Grinvalds/Shutterstock*

How do heat engines work? What factors determine the efficiency of a heat engine, and how can efficiency be maximized? The second law of thermodynamics plays a central role. Heat engines will lead us to an exploration of the second law and the related concept of entropy.

## 11.1 Heat Engines

Think for a moment about what the internal combustion engine in your car does. We have said that both steam engines and gasoline engines are heat engines. What does this mean? We know that fuel is burned in the engine and that work is done to move the car. Somehow, work is generated from heat released in burning the fuel. Can we develop a model that describes the basic features of all heat engines?

### What does a heat engine do?

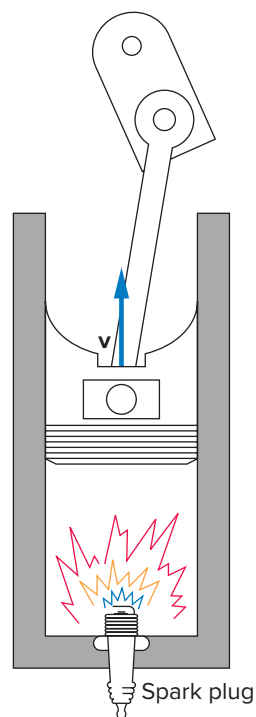
Let's sketch a description of what the gasoline engine in your car does: Fuel in the form of gasoline is mixed with air and introduced into a can-shaped chamber in the engine called a *cylinder*. A spark produced by a spark plug ignites the gas-air mixture, which burns rapidly (fig. 11.2). Heat is released from the fuel as it burns, which causes the gases in the cylinder to expand, doing work on the piston.

Through mechanical connections, work done on the pistons is transferred to the drive shaft and to the wheels of the car. The wheels push against the road surface, and by Newton's third law, the road exerts a force on the tires that does the work to move the car.

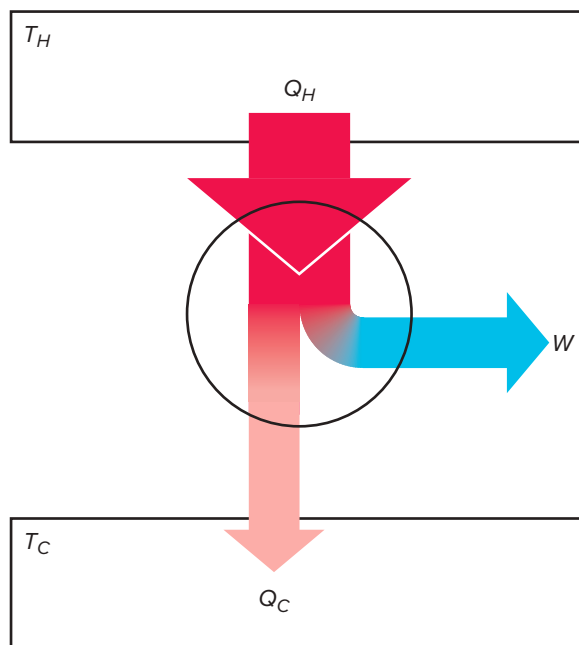
Not all of the heat obtained from burning fuel is converted to work done in moving the car. The exhaust gases emerging from the tailpipe of the car are hot, so some heat is released into the environment. Unused heat is a general feature of the operation of a heat engine.

This general description shows you the features common to all heat engines: Thermal energy (heat) is introduced into

the engine. Some of this energy is converted to mechanical work. Some heat is released into the environment at a temperature lower than the input temperature. Figure 11.3 presents these ideas schematically. The circle represents the heat



**Figure 11.2** Heat released by burning gasoline in the cylinder of an automobile engine causes the piston to move, converting some of the heat to work.



**Figure 11.3** A schematic representation of a heat engine. Heat is taken in at high temperatures,  $T_H$ . Some heat is converted to work, and the remainder is released at a lower temperature,  $T_C$ .

engine. The box at the top is the high-temperature source of heat, and the box at the bottom is the lower-temperature environment into which the *waste heat* is released.

### Efficiency of a heat engine

How much useful mechanical work can an engine produce for a given energy input of heat? It is important to know how productive or efficient an engine is. **Efficiency** is defined as the *ratio* of the net work done by the engine to the amount of heat that must be supplied to accomplish this work. In symbols,

$$e = \frac{W}{Q_H}$$

where  $e$  is the efficiency,  $W$  is the net work done by the engine, and  $Q_H$  is the quantity of heat taken in by the engine from the high-temperature source, or *heat reservoir*. The work  $W$  is positive, because it represents work done *by* the engine on the surroundings. (The subscripts  $H$  and  $C$  used in this and subsequent sections stand for *hot* and *cold*.)

In example box 11.1, a heat engine takes in 1200 J of heat from a high-temperature source and does 400 J of work in each cycle, resulting in an efficiency of one-third. We usually state efficiency as a decimal fraction, 0.33, or 33% in this case. An efficiency of 33% is greater than that of most automobile engines but less than that of the steam turbines powered by coal or oil and used in many electric power plants.

In computing this efficiency, we used heat and work values for one *complete* cycle. An engine usually functions in cycles, in which the engine repeats the same process over and over. It is necessary to use a complete cycle or an average of several

## Example Box 11.1

### Sample Exercise: How Efficient Is This Engine?

A heat engine takes in 1200 J of heat from the high-temperature heat source in each cycle and does 400 J of work in each cycle.

- What is the efficiency of this engine?
- How much heat is released into the environment in each cycle?

$$\begin{aligned} \text{a. } Q_H &= 1200 \text{ J} & e &= \frac{W}{Q_H} \\ W &= 400 \text{ J} & &= \frac{400 \text{ J}}{1200 \text{ J}} \\ e &= ? & &= \frac{1}{3} = 0.33 \\ & & &= \mathbf{33\%} \end{aligned}$$

$$\begin{aligned} \text{b. } Q_C &= ? & W &= Q_H - Q_C \\ \text{so } Q_C &= Q_H - W & &= 1200 \text{ J} - 400 \text{ J} \\ & & &= \mathbf{800 \text{ J}} \end{aligned}$$

complete cycles to compute efficiency, because heat and work exchanges occur at different points within the cycle.

### What does the first law of thermodynamics tell us about heat engines?

The first law of thermodynamics places some limits on what a heat engine can do. Because the engine returns to its initial state at the end of each cycle, its internal energy at the end of the cycle has the same value as at the beginning. The change in the internal energy of the engine for one complete cycle is zero.

The first law states that the change in internal energy is the difference between the net heat added and the net work done by the engine ( $\Delta U = Q - W$ ). Because the change in internal energy  $\Delta U$  is zero for one complete cycle, the net heat  $Q$  flowing into or out of the engine per cycle must equal the work  $W$  done by the engine during the cycle. Energy is conserved.

Net heat is the difference between the heat input from the higher-temperature source  $Q_H$  and heat released to the lower-temperature (or colder) environment  $Q_C$ . The first law of thermodynamics shows that the net work done by the heat engine in one complete cycle is

$$W = Q_H - |Q_C|$$

because the work done equals the net heat.\*

In the sample exercise in example box 11.1, 800 J of heat are released to the environment. The widths of the arrows in figure 11.4 correspond to the quantities of heat and work

\*We are using the absolute value of  $Q_C$ , as indicated by the vertical bars. Because  $Q_C$  flows out of the engine, it is often considered a negative quantity. The relationship is clearer if we make the minus sign explicit.

## Everyday Phenomenon

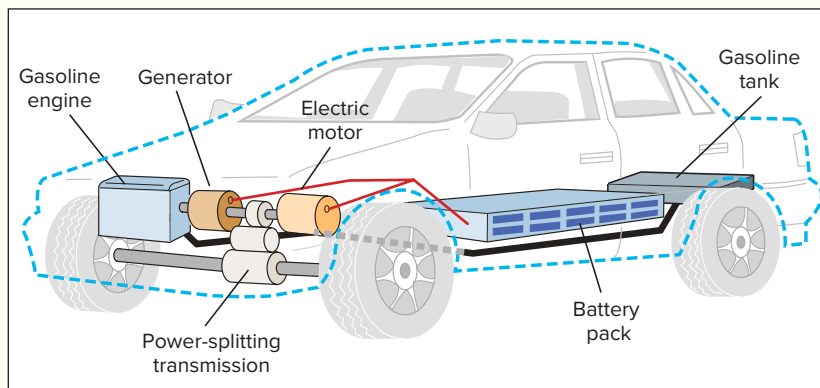
## Box 11.1

## Hybrid Automobile Engines

**The Situation.** Automobile companies have been working for years to develop better engines and drive systems. The goals are to achieve greater efficiency and lower exhaust emissions without excessive increases in cost. Federal and state environmental regulations provide incentive.

Electric cars have been one solution. Although electric motors produce essentially no exhaust emissions, electric cars suffer from limited range, weight issues associated with the storage batteries, and the need to recharge for several hours with relatively high-cost electric power. The introduction of hybrid systems that involve both an electric motor and a gasoline engine is a more recent development. How do these hybrid systems work? What are their advantages and disadvantages?

**The Analysis.** Although different arrangements are possible, most hybrid designs allow both the electric motor and the gasoline engine to turn the transmission, which transmits power to the drive wheels of the car. The gasoline engine is a heat engine, but the electric motor is not. The electric motor converts electrical energy stored in batteries to mechanical energy to drive the car. Either or both engines can power the car depending on conditions. A sophisticated power-splitting transmission is needed to direct the energy flows.



The gasoline engine and the electric motor can both drive the wheels of a hybrid car. The gasoline tank and battery pack represent different ways of storing energy.

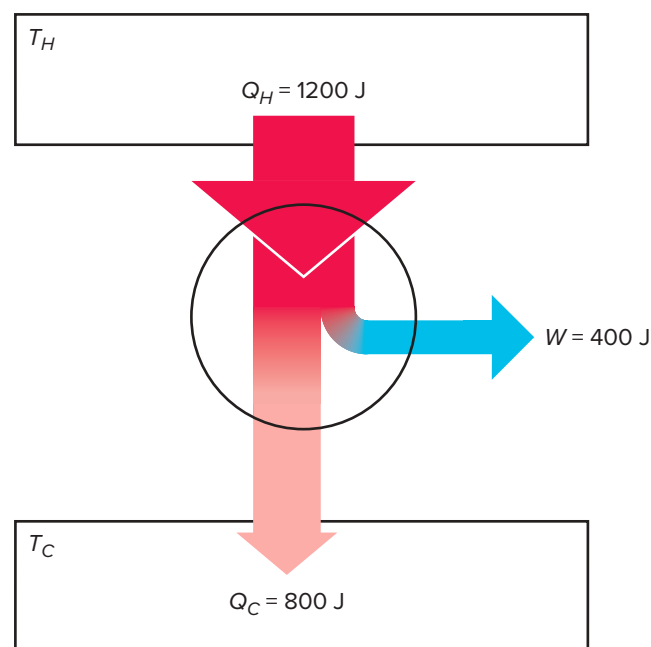
In city-driving conditions, the electric motor is used to power the car when starting from a complete stop or accelerating at low speeds. This avoids the exhaust emissions associated with using a gasoline engine at speeds at which it is not very efficient. It also avoids the need for a large gasoline engine that would otherwise be required for good acceleration. The gasoline engine can even be turned off in these situations.

In highway driving, the gasoline engine provides the primary power, with the electric motor kicking in when extra acceleration is needed. At times when the full power of the gasoline engine is not needed to drive the car, it is also used to drive a generator to produce electricity to charge the batteries. (See chapter 14 for a discussion of

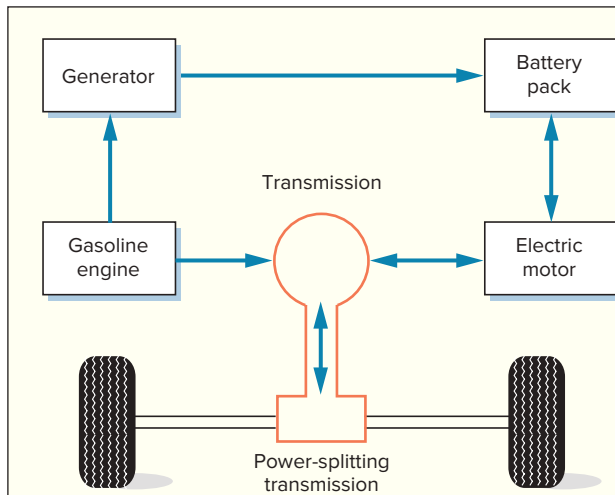
involved in this example. Start with the wide arrow at the top. In each cycle, 1200 J of heat are taken in, 400 J (one-third of the total) are converted to work, and 800 J of heat (two-thirds of the total) are released to the lower-temperature reservoir. The arrow representing the released heat is twice as wide as the arrow depicting the work, and the combined width of these two arrows equals the width of the arrow of the original heat input.

Automobile engines, diesel engines, jet engines, and the steam turbines used in power plants are all heat engines. You can create a simple steam turbine by placing a pinwheel in front of the spout of a tea kettle, as in figure 11.5. The input heat is supplied to the tea kettle by the stove or hot plate. Some of this heat is converted to work in turning the pinwheel. The rest of the heat is released into the room and does no work on the pinwheel, although it does warm the room slightly.

If a string or thread were attached to the shaft of the pinwheel, work done on the pinwheel could be used to lift a small weight. This pinwheel steam turbine would not be powerful or efficient. Designing better engines with both high power (the rate of doing work) and high efficiency (the fraction of input heat converted to work) has been the goal of scientists and mechanical engineers for the last two hundred years. Everyday phenomenon box 11.1 discusses



**Figure 11.4** The arrow widths depict the quantities of energy in the sample exercise in example box 11.1.



Flowchart showing the possible directions of energy flow in a hybrid vehicle. During braking, energy flows from the wheels to the battery pack via the electric motor.

electric motors and generators.) Electric power can also be generated by running the electric motor in reverse when the car is going downhill or braking for a stop. In this way, we recapture and store energy in the batteries that would otherwise be lost as low-grade heat.

The flowchart shows the different possible directions of energy flow in a hybrid vehicle. The advantages of the hybrid system are these:

1. Because we are not using the gasoline engine for the peak power needed for acceleration, we can get by with a small gasoline engine. The smaller the engine, the greater the fuel economy.

2. The batteries of the hybrid car are charged by the gasoline engine and the recapture of energy in the braking process. They do not need to be recharged overnight (or with stops) with electric power, as is required for all-electric cars. Also, we do not need as large a battery pack for the hybrid vehicle as that required for decent range in an all-electric car.
3. Because it is used mainly for highway driving and running the generator, the gasoline engine can operate at its most efficient speed. This leads to lower exhaust emissions, which are greatest at low speeds and high accelerations.

The disadvantages of hybrid systems lie primarily in the extra cost of having both a gasoline engine and a relatively large electric motor, as well as a sophisticated transmission for directing the power between these two sources. (Standard gasoline-engine automobiles require an electric motor as the starter, but the electric motor used in hybrid cars must have higher power and greater size.) The hybrid car also has an expensive battery pack, which ultimately will need to be replaced.

These disadvantages are reflected in a higher cost for the hybrid vehicle than for a standard gasoline vehicle of similar size and features. Despite this, hybrid cars have gained quick acceptance from people who are aware of the environmental benefits of better fuel economy and lower emissions. More stringent environmental regulations will make hybrid vehicles and all-electric cars more attractive options.



a recent development in this effort. Discovering the factors that have an impact on efficiency is an important part of this quest.

A heat engine takes in heat from a high-temperature source, converts part of this heat into work, and releases the remaining heat to the environment at a lower temperature. Gasoline engines in cars, jet engines, rocket engines, and steam turbines are all heat engines. The efficiency of an engine is the ratio of work done by the engine to the amount of heat taken in from the high-temperature source. Because the change in internal energy is zero for a complete cycle, the first law of thermodynamics requires that the work done in one cycle equal the net heat flow into and out of the engine.

**Figure 11.5** Steam issuing from the kettle makes the pinwheel turn in this simple steam turbine. Work could be done to lift a small weight with such an engine.

Jill Braaten



## 11.2 The Second Law of Thermodynamics

If the efficiency of a typical automobile engine is less than 30%, we seem to be wasting a lot of energy. What is the best efficiency that we could achieve? What factors determine efficiency? These questions are as important today for automotive engineers or designers of modern power plants as they were for the early designers of steam engines.

### What is a Carnot engine?

One of the earliest scientists to be intrigued by these questions was a young French engineer named Sadi Carnot (1796–1832). Carnot was inspired by the work of his father, also an engineer, who had studied and written about the design of water wheels, an important source of mechanical power at the time.

The workings of a water wheel provided Carnot with the basis for modeling an ideal heat engine. Carnot's father realized that bringing in all of the water at the highest point and releasing it at the lowest point maximized the efficiency of the water wheel. Carnot reasoned that the greatest efficiency of a heat engine would be obtained by taking in all of the input heat at a single high temperature and releasing all of the unused heat at a single low temperature. This would maximize the effective temperature difference within the limits of the temperatures of the heat source and the environment.

Carnot imposed another requirement on his ideal engine: All of the processes had to occur without undue turbulence or departure from equilibrium. This requirement also paralleled his father's ideas on water wheels. In an ideal heat engine, the working fluid of the engine (steam, or whatever else might be used) should be roughly in equilibrium at all points in the cycle. This condition means that the engine is completely **reversible**—it can be turned around and run the other way at any point in the cycle, because it is always near equilibrium.

The requirement that a system be essentially in equilibrium at each point in some process (which makes the

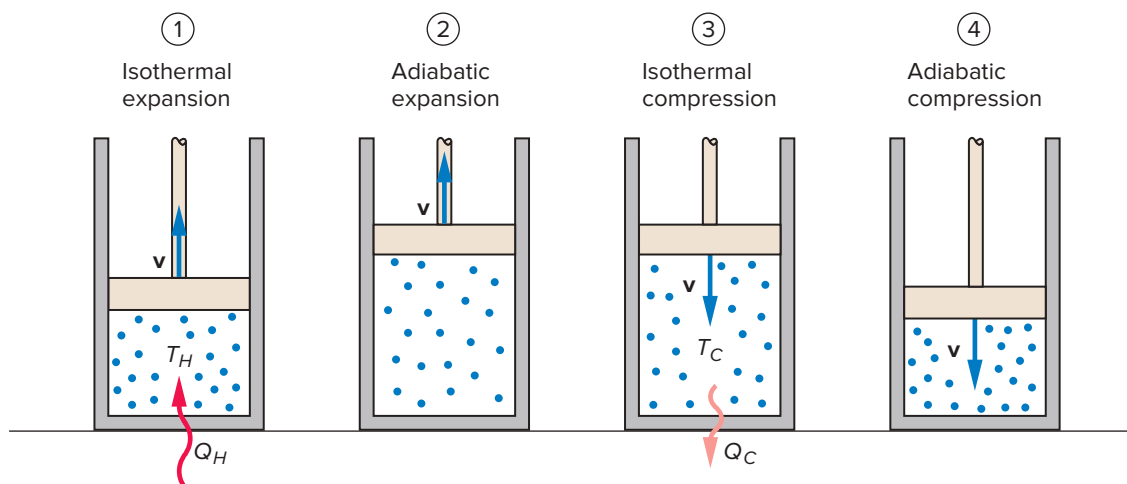
process reversible) is an idealization. Most real processes are irreversible to some extent. The explosion of gasoline and air in the cylinder of an automobile engine, for example, is highly irreversible—the system is nowhere near equilibrium during the explosion. Cracking an egg into a pan and frying it is another example of an irreversible process. It would be impossible to “unfry” the egg and put it back into its shell.

When Carnot published his paper on the ideal heat engine in 1824, the energy aspects of heat and the first law of thermodynamics were not yet understood. Carnot pictured caloric flowing through his engine, just as water flowed through a water wheel. It was not until after the development of the first law around 1850 that the full impact of Carnot's ideas became apparent. It then became clear that heat does not simply flow through the engine. Some of the heat is converted to mechanical work done by the engine.

### What are the steps in a Carnot cycle?

The cycle devised by Carnot for an *ideal* heat engine is illustrated in figure 11.6. Imagine a gas or some other fluid contained in a cylinder with a movable piston. In step 1 of the cycle (the energy input), heat flows into the cylinder at a single high temperature,  $T_H$ . The gas or fluid expands *isothermally* (at constant temperature) during this process and does work on the piston. In step 2, the fluid continues to expand, but no heat is allowed to flow between the cylinder and its surroundings. This expansion is *adiabatic* (with no heat flow).

Step 3 is an isothermal compression—work is done by the piston on the fluid to compress the fluid. This is the exhaust step, because heat,  $Q_C$ , flows out of the fluid at a single low temperature,  $T_C$ , during this compression. The final step, step 4, returns the fluid to its initial condition by an additional compression done adiabatically. All four steps must be done slowly, so that the fluid is in approximate equilibrium at all times. The complete process is then *reversible*, a crucial feature of the **Carnot engine**.



**Figure 11.6** The Carnot cycle. Step 1: isothermal expansion; step 2: adiabatic expansion; step 3: isothermal compression; step 4: adiabatic compression.

When the fluid is expanding in steps 1 and 2, it is doing positive work on the piston that can be transmitted by mechanical links for another use. In steps 3 and 4, the fluid is being compressed, which requires that work be done on the engine by external forces. The work added in steps 3 and 4 is less than the amount done by the engine in steps 1 and 2, however, so that the engine does a net amount of work on the surroundings.

### What is the efficiency of a Carnot engine?

The first law of thermodynamics made it possible to compute the efficiency of the *Carnot cycle* by assuming that the working fluid was an ideal gas. The process involves computing the work done on or by the gas in each step and the quantities of heat that must be added and removed in steps 1 and 3. For a Carnot cycle, and only for a Carnot cycle, it turns out that the ratio of the hot and cold temperatures (in Kelvin) is equal to the ratio of the heat added and lost. Using this information and the definition of efficiency from section 11.1, we obtain

$$e_c = \frac{T_H - T_C}{T_H}$$

where  $e_c$  is the **Carnot efficiency** and  $T_H$  and  $T_C$  are the *absolute* temperatures (in Kelvin) at which heat is taken in and released. This form of the efficiency equation is valid only for a Carnot engine.

Example box 11.2 illustrates these ideas. For the temperatures given, a Carnot efficiency of approximately 42% is obtained. According to Carnot's ideas, this would be the *maximum efficiency possible* for any engine operating between these two temperatures. Any real engine operating between these two temperatures has a somewhat lower efficiency, because it is impossible to run a real engine in the completely reversible manner required for a Carnot engine.

### The second law of thermodynamics

The absolute temperature scale was developed in the 1850s by Lord Kelvin in England. Kelvin was aware of Joule's experiments and had a hand in the statement of the first law of thermodynamics. He was in an excellent position to take a fresh look at Carnot's ideas on heat engines.

By combining Carnot's ideas with the new recognition that heat flow is a transfer of energy, Kelvin put forth a general principle, or law of nature. This principle, which we now call the **second law of thermodynamics**, is usually stated as follows:

No heat engine, working in a continuous cycle, can take heat from a reservoir at a single temperature and convert that heat completely to work.

## Example Box 11.2

### Sample Exercise: Carnot Efficiency

A steam turbine takes in steam at a temperature of 400°C and releases steam to the condenser at a temperature of 120°C.

- What is the Carnot efficiency for this engine?
- Assume for the moment that Carnot efficiency is possible (it is not). If the turbine takes in 500 kJ of heat in each cycle, what is the maximum amount of work that could be generated by the turbine in each cycle?
- The efficiency of a very good steam engine can be as high as 37%. If the turbine takes in 500 kJ of heat in each cycle, what is the maximum amount of work that could realistically be generated by the turbine in each cycle?

$$\begin{aligned} \text{a. } T_H &= 400^\circ\text{C} & e_c &= \frac{T_H - T_C}{T_H} \\ &= 673 \text{ K} & & \\ T_C &= 120^\circ\text{C} & &= \frac{673 \text{ K} - 393 \text{ K}}{673 \text{ K}} \\ &= 393 \text{ K} & & \\ e &= ? & &= \frac{280 \text{ K}}{673 \text{ K}} \\ & & &= \mathbf{0.416} \text{ (41.6\%)} \end{aligned}$$

$$\begin{aligned} \text{b. } Q_H &= 500 \text{ kJ} & e &= \frac{W}{Q_H}, \text{ so } W = eQ_H \\ W &= ? & &= (0.416)(500 \text{ kJ}) \\ & & &= \mathbf{208 \text{ kJ}} \end{aligned}$$

$$\begin{aligned} \text{c. } Q_H &= 500 \text{ kJ} & e &= \frac{W}{Q_H}, \text{ so } W = eQ_H \\ e &= 0.37 & &= (0.37)(500 \text{ kJ}) \\ W &= ? & &= \mathbf{185 \text{ kJ}} \end{aligned}$$

In other words, it is not possible for any heat engine to have an efficiency of 1, or 100%.

Using the second law of thermodynamics, we can also show that no engine operating between two given temperatures can have a greater efficiency than a Carnot engine operating between the same two temperatures. This proof, which involves the reversible feature of the Carnot cycle, justifies Carnot's contention that the Carnot engine is the best that can be achieved. In fact, if an engine did have an efficiency greater than the Carnot efficiency, the second law of thermodynamics would be violated. This argument is illustrated in figure 11.7.

Here is how the argument goes: An engine with an efficiency greater than the Carnot engine would produce a greater amount of work than the Carnot engine for the same amount of heat input  $Q_H$ . Some of this work could be used to run the Carnot engine in reverse, returning the heat released by the first engine to the higher-temperature reservoir. To run the engine in reverse, we reverse the directions of the arrows without changing the quantities of heat and work.

The remaining work ( $W_{\text{excess}}$  in figure 11.7) would be available for external use, and no heat would end up in the

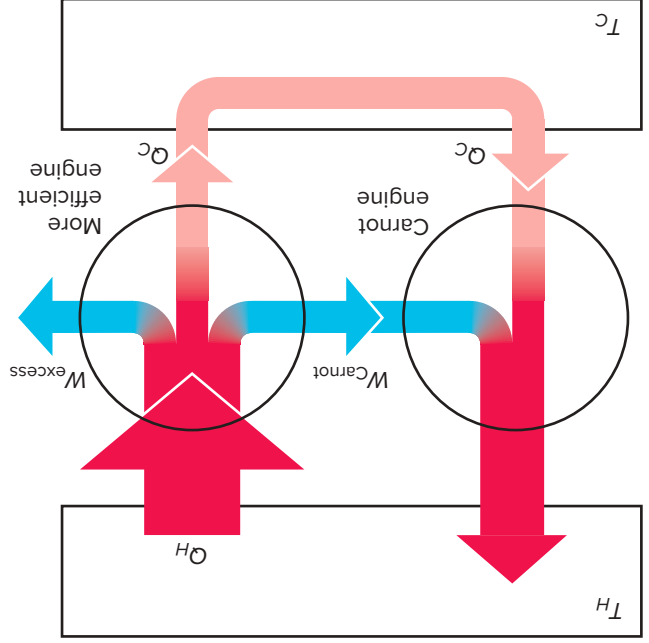
### 11.3 Refrigerators, Heat Pumps, and Entropy

To a teenager, the automobile and refrigerator just might be the two most important inventions. The gasoline engine in an automobile is a heat engine. What is a refrigerator? In section 11.2, we talked about running a heat engine in reverse, with the result that work was used to pump heat from a colder to a hotter reservoir. Is this what a refrigerator does? Is there a relationship between heat engines and refrigerators?

#### What do refrigerators and heat pumps do?

We are all familiar with refrigerators, even if we do not understand how they function. A refrigerator keeps food cold by pumping heat out of the cooler interior of the refrigerator into the warmer room (fig. 11.8). An electric motor or gas-powered engine does the necessary work. A refrigerator also warms the room, as you can tell by holding your hand near the coils on the back of the refrigerator when it is running.

Figure 11.9 shows a diagram of a heat engine run in reverse: It is the same diagram used for heat engines, but the directions of the arrows showing the flow of energy have been reversed. Work  $W$  is done on the engine, heat  $Q_c$  is



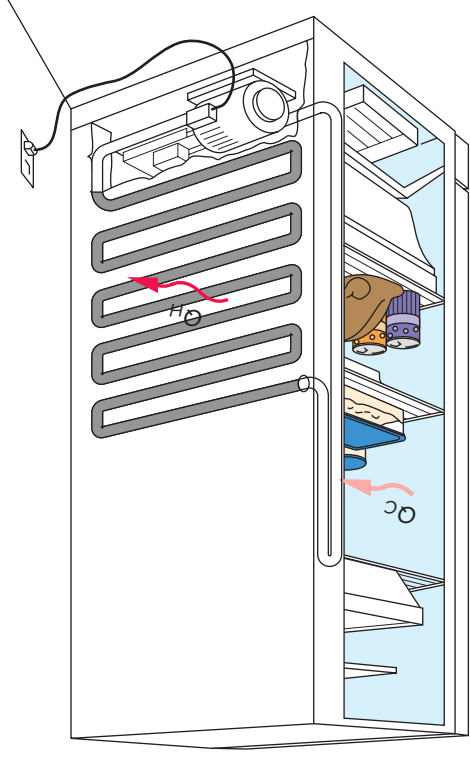
**Figure 11.7** A diagram showing that if an engine had a greater efficiency than a Carnot engine operating between the same two temperatures, the second law of thermodynamics would be violated.

lower-temperature reservoir. The two engines operating in tandem would take a small quantity of heat from the higher-temperature reservoir and convert it *completely* to work. This would violate the second law of thermodynamics. Therefore, no engine can have a greater efficiency than a Carnot engine operating between these two reservoirs.

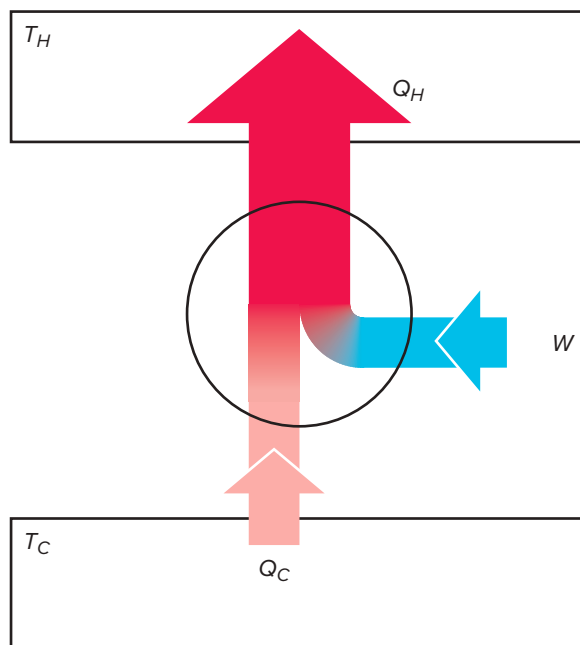
The Carnot efficiency is thus the maximum possible efficiency for any heat engine operating between these two temperatures. Because the proof follows from the second law of thermodynamics, the Carnot efficiency is sometimes referred to as the *second-law efficiency*.

The second law of thermodynamics cannot be proved. It is a law of nature, which, as near as we know, cannot be violated. It sets a limit on what can be achieved with heat energy. Time has shown it to be an accurate statement. The second law is consistent with what we know about heat transfer, heat engines, refrigerators, and many other phenomena.

Sadi Carnot developed the concept of a completely reversible, ideal heat engine. The Carnot engine takes in all of its heat at a single high temperature and releases the unused heat at a single low temperature; its efficiency depends on this temperature difference. The second law of thermodynamics as stated by Lord Kelvin says that no continuously operating engine can take in heat at a single temperature and convert that heat completely to work. Relying on the second law, we can show that no engine can have a greater efficiency than a Carnot engine operating between the same two temperatures.



**Figure 11.8** A refrigerator pumps heat from the cooler interior of the refrigerator to the warmer room. The heat-exchange coils that release heat to the room are usually on the back side of the refrigerator.



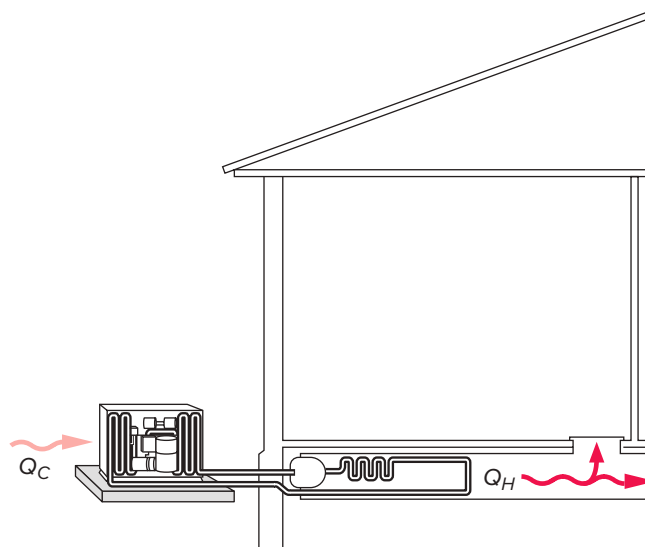
**Figure 11.9** A diagram of a heat engine run in reverse. In reverse, the heat engine becomes a heat pump or refrigerator. The lower box, where the  $Q_C$  is removed, represents the inside of a refrigerator, or the cooler outdoors for a heat pump. The higher-temperature heat,  $Q_H$ , is released into the room in both cases.

removed from the lower-temperature reservoir, and a greater quantity of heat  $Q_H$  is released to the higher-temperature reservoir. A device that moves heat from a cooler reservoir to a warmer reservoir by means of work supplied from some external source is called a **heat pump** or a *refrigerator*.

The first law of thermodynamics requires that for a complete cycle, the heat released at the higher temperature must equal the energy put into the engine in the form of *both heat and work*. As before, the engine returns to its initial condition at the end of each cycle—the internal energy of the engine does not change. More heat is released at the higher temperature than was taken in at the lower temperature (fig. 11.9). For example, if 200 J of work were used to move 300 J of heat from the lower-temperature reservoir, then 500 J of heat would be delivered to the higher-temperature reservoir.

While a refrigerator is a heat pump, the term *heat pump* usually refers to a device that heats a building by pumping heat from the colder outdoors to the warmer interior (fig. 11.10). An electric motor does the work needed to run the pump. The amount of heat energy available to heat the house is greater than the work supplied, because  $Q_H$  is equal in magnitude to the sum of the work  $W$  and the heat  $Q_C$  removed from the outside air. We can get a larger amount of heat from the heat pump than by converting the electrical energy directly to heat, as is done in an electric furnace.

Two sets of coils are used for heat exchange in the heat pump—one sits outside (fig. 11.11) and removes heat from the outside air, while the other releases heat to the air inside the building. Many heat pumps are designed to pump heat in



**Figure 11.10** A heat pump removes heat from the outside air and pumps it into the warmer house.

either direction and can be used as air conditioners in the summer. (Most air conditioners are heat pumps that pump heat from inside a building to the warmer exterior.) Heat pumps are most effective for heating houses in climates where the winters are mild and the difference between the outside temperature and inside temperature is not too large.

A heat pump can deliver a quantity of heat to the inside of the building that is often two to three times the amount of electric energy supplied as work. Again, the first law of thermodynamics is not violated because the extra energy is being supplied from the outside air. The work applied to the heat pump allows us to move thermal energy in the direction opposite its natural tendency, much as a water pump moves water uphill.



**Figure 11.11** The exterior heat-exchange coils for an air-to-air heat pump are usually located behind the house or building.  
Mark Dierker/McGraw-Hill Education

## The Clausius statement of the second law of thermodynamics

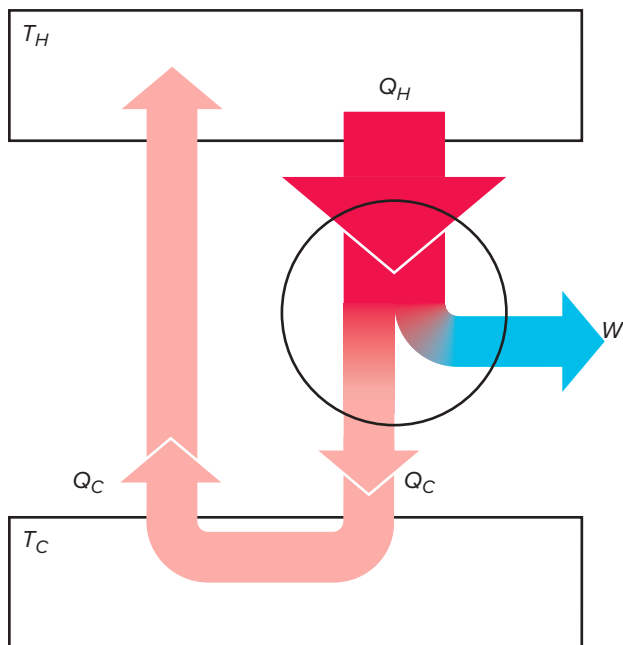
Heat normally flows from hotter objects to colder objects. This natural tendency is the basis for another statement of the second law of thermodynamics. Often called the Clausius statement after its originator, Rudolf Clausius (1822–1888), it takes this form:

Heat will not flow from a colder body to a hotter body unless some other process is also involved.

In the case of a heat pump, the other process is the work used to pump the heat against its usual direction of flow.

Although this statement of the second law sounds very different from the Kelvin statement, they both express the same fundamental law of nature. They both place limits on what can be done with heat, and the limits in each statement are equivalent. This can be shown by an argument similar to the one that confirmed that no engine can have a greater efficiency than a Carnot engine operating between the same two temperatures.

Figure 11.12 illustrates the argument. If it were possible for heat to flow from the colder to the hotter reservoir without any work, heat released by the heat engine on the right side of the diagram could flow back to the hotter reservoir. Some heat could then be removed from the hotter reservoir and converted *completely* to work. Heat would not be added to the cooler reservoir. This result violates the Kelvin statement of the second law of thermodynamics, which says that taking heat from a reservoir at a single temperature and converting it completely to work is impossible.



**Figure 11.12** If we assume that heat can flow spontaneously from a colder to a hotter reservoir, the Kelvin statement of the second law of thermodynamics is violated.

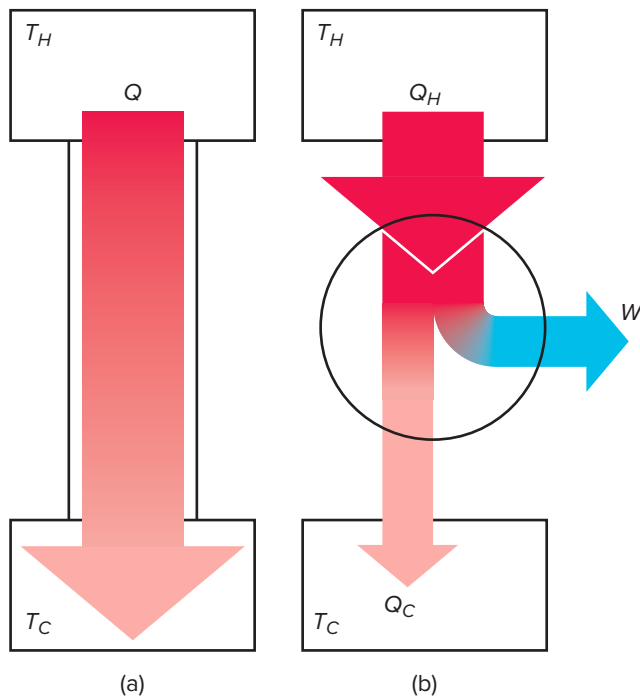
A violation of the Clausius statement of the second law is therefore a violation of the Kelvin statement. A similar argument will show that a violation of the Kelvin statement is a violation of the Clausius statement. (You may want to try your hand at developing this argument.) These two statements express the same fundamental law of nature in two different ways.

## What is entropy?

Is there something inherent in heat that leads to the limitations described in the two statements of the second law of thermodynamics? Both statements of the second law describe processes that do not violate the first law of thermodynamics (conservation of energy)—but apparently are not possible. Certain things cannot be done with heat energy.

Suppose we had a quantity of heat in a high-temperature reservoir (perhaps just a container of hot water). We could imagine two different ways to remove heat from the source. First, we could simply let the heat flow through a good heat conductor into the cooler environment, as shown in figure 11.13a.

Second, we could use this heat to run a heat engine and do some useful work (fig. 11.13b). If we were to use a Carnot engine, the process is completely reversible and we have obtained the maximum possible work from the available heat. The first process, heat simply flowing through a conductor to the lower-temperature reservoir, is *irreversible*. The system is not in equilibrium while this heat flow takes place, and the energy is not converted to useful work. In the irreversible process, *we lose some ability to do useful work*.



**Figure 11.13** Heat can be removed from a high-temperature source either by direct flow through a conducting material or by being used to run a heat engine.

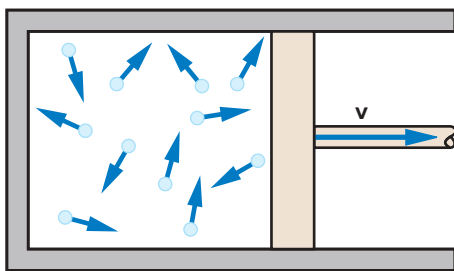
**Entropy** is the quantity that describes the extent of this loss. As entropy increases, we lose the ability to do work. Entropy is sometimes defined as a *measure of the disorder of the system*. The entropy of a system increases anytime the disorder or randomness of the system increases. A system organized into two reservoirs at two distinct temperatures is, in this sense, more organized than having the energy all at a single intermediate temperature.

If we use the heat available in the hotter reservoir to run a completely reversible Carnot engine, there is no increase in the entropy of the system and its surroundings. We get the maximum useful work from the available energy. In isolated systems (as well as in the universe), entropy remains constant in *reversible* processes but increases in *irreversible* processes where conditions are not in equilibrium. The entropy of a system decreases only if it interacts with some other system whose entropy is increased in the process. (This happens, for example, in the growth and development of biological organisms.) The entropy of the universe never decreases. This statement is yet another version of the second law of thermodynamics:

The entropy of the universe or of an isolated system can only increase or remain constant. Its entropy cannot decrease.

The randomness of heat energy is responsible for the limitations in the second law of thermodynamics. The entropy of the universe would decrease if heat could flow by itself from a colder to a hotter body—but the Clausius statement of the second law says this cannot happen. Likewise, the entropy of the universe would decrease if heat at a single temperature could be converted completely to work, violating the Kelvin statement of the second law.

The thermal energy of a gas consists of the kinetic energy of the molecules. The velocities of these molecules are randomly directed, however, as in figure 11.14. Only some of the molecules move in the proper direction to push the piston to produce work. If the molecules all moved in the same direction, we could convert their kinetic energy completely to work. This would be a lower-entropy (more organized) condition, but it does not represent the normal condition for



**Figure 11.14** The random directions of gas molecules prevent us from completely converting their kinetic energy to useful mechanical work.

the thermal energy in a gas. The basic disorganization of heat energy is responsible for the limitations encompassed by the three statements of the second law.

Like internal energy, entropy can be computed for any state of a given system. The notion of disorder or randomness is at the heart of the matter. The state of a student's residence-hall room tends to become more disordered. This natural tendency of entropy to increase can only be countered by introducing energy in the form of work to straighten things up again.

A heat pump or refrigerator is a heat engine run in reverse: Work is supplied to pump heat from a colder to a hotter body. The Clausius statement of the second law of thermodynamics, which is equivalent to the Kelvin statement, says that heat normally flows from a hotter to a colder body and cannot flow in the opposite direction without some other process being involved. The limitations on the use of heat expressed in the second law come about because of the disorganized nature of heat energy. Entropy is a measure of the disorder of a system. The entropy of the universe can only increase.

## 11.4 Thermal Power Plants and Energy Resources

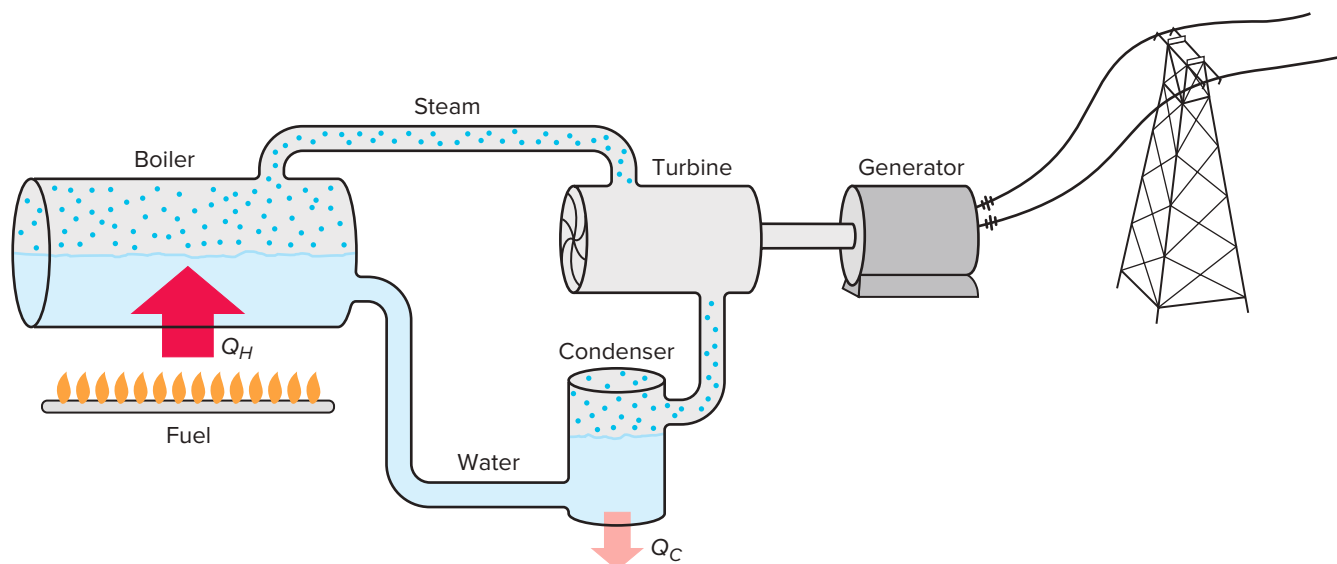
We use electric power so routinely that most of us do not stop to think about where that energy comes from. Concerns about the greenhouse effect (see everyday phenomenon box 10.2) and other environmental issues have recently pushed questions about how we generate electric power back into public debate. How is electric power generated in your area? If hydroelectric power is not a major contributor, most of your power comes from thermal power sources that use heat engines.

Thermodynamics plays an extremely important role in any discussion of the use of energy. What are the most efficient ways of using energy resources such as coal, oil, natural gas, nuclear energy, solar energy, and geothermal energy? What bearing do the laws of thermodynamics and the efficiency of heat engines have on these questions?

### How does a thermal power plant work?

The most common way of producing electric power in most countries is a **thermal power plant** fueled by coal, oil, or natural gas (fossil fuels). The heart of such a plant is a heat engine. The fuel is burned to release heat, which causes the temperature of the working fluid (usually water and steam) to increase. Hot steam is run through a turbine (fig. 11.15), which turns a shaft connected to an electric generator. Electricity is then transmitted through power lines to consumers (such as homes, offices, and factories).

Because the steam turbine is a heat engine, its efficiency is inherently limited by the second law of thermodynamics



**Figure 11.15** The basic components of a thermal-electric power plant. Heat from the boiler generates steam, which turns the steam turbine. The turbine does work to generate electric power in the generator.

to the maximum given by the Carnot efficiency. The efficiency of a real heat engine is always less than this limit, because it falls short of the ideal conditions of a Carnot engine. In any real engine, there are always irreversible processes taking place. A steam turbine generally comes closer to the ideal, however, than the internal combustion engines used in automobiles. Rapid burning of gasoline-and-air mixtures in an automobile engine involves highly turbulent and irreversible processes.

Because the maximum possible efficiency is dictated by the temperature difference between the hot and cold reservoirs, heating the steam to as high a temperature as the materials will permit is advantageous. The materials the boiler and turbine are made from set an upper limit on the temperatures that can be tolerated. If these materials begin to soften or melt, the equipment will obviously deteriorate. For most steam turbines, the upper temperature limit is around  $600^{\circ}\text{C}$ , well below the melting point of steel. In practice, most turbines operate at temperatures below this limit— $550^{\circ}\text{C}$  is typical.

If a steam turbine is operating between an input temperature of  $600^{\circ}\text{C}$  ( $873\text{ K}$ ) and an exhaust temperature near the boiling point of water ( $100^{\circ}\text{C}$ , or  $373\text{ K}$ ) where the steam condenses to water, we can compute the maximum possible efficiency for this turbine:

$$e_c = \frac{T_H - T_C}{T_H}$$

The difference between these two temperatures is  $500\text{ K}$ . Dividing this by the input temperature of  $873\text{ K}$  yields a Carnot efficiency of  $0.57$ , or  $57\%$ . This is the ideal efficiency. The actual efficiency will be somewhat lower and usually runs between  $40\%$  and  $50\%$  for modern coal- or oil-fired power plants.

At best, we can convert about half of the thermal energy released in burning coal or oil to mechanical work or electrical energy. The rest must be released into the environment at temperatures too low for running heat engines or most other functions except space heating. The exhaust side of the turbines must be cooled to achieve maximum efficiency, and the cooling water is either returned to some body of water or run through cooling towers, where the heat is dissipated into the atmosphere (fig. 11.16). This is the *waste heat* often referred to in discussions of the environmental impact of power plants. If the waste heat is dumped into a river, the temperature of the river will rise, with possible effects on the fish and other wildlife.



**Figure 11.16** The cooling towers that are a common feature of many thermal power plants transfer heat from the cooling water to the atmosphere.

*AbleStock.com/Getty Images*

### Alternatives to fossil fuels

Nuclear power plants, discussed in chapter 19, also generate heat to run steam turbines. Because of the effects of radiation on materials, however, it is not feasible to run the turbines in a nuclear plant at temperatures as high as those in fossil-fuel plants. The thermal efficiencies for nuclear plants are somewhat lower, typically between 30% and 40%.

For equal amounts of energy generated, the amount of heat released into the environment is somewhat larger for a nuclear plant than for a fossil-fuel plant. On the other hand, nuclear power plants do *not* release carbon dioxide and other exhaust gases into the atmosphere and do not contribute to the greenhouse effect. Processing and disposal of nuclear wastes and concerns about nuclear accidents continue to be significant issues.

Heat is also available from other sources, such as geothermal energy, which is heat that comes from the interior of the Earth. Hot springs and geysers indicate the presence of hot water near the surface of the Earth that might be used for power production, but usually the temperature of the water is not much greater than 200°C. In places where steam is available from geysers, low-temperature steam turbines can be run, as in the geothermal power plant in Iceland shown in figure 11.17.

If the water temperature is below 200°C, steam turbines are not effective, and some other fluid with a lower boiling temperature than water is preferable for running a heat engine. Isobutane has been studied as a possible working fluid for low-temperature heat engines. The efficiency of such an engine would be quite low, however. If water were available at a temperature of 150°C (423 K), for example, and cooling water were available at 20°C (293 K), the Carnot efficiency would be 31%. In practice, the efficiency would be even less, so it is common to find efficiencies of only 20% to 25% in proposed geothermal power plants.

Warm ocean currents are yet another source of heat. Prototypes have been developed of ocean power plants that take advantage of the temperature difference between warm water at the surface of an ocean and cooler water drawn from greater depths. Example box 11.3 illustrates a possible



**Figure 11.17** This geothermal power plant in Iceland uses geothermal energy to run steam turbines.

Javarman/Shutterstock

### Example Box 11.3

#### Sample Exercise: What Is the Efficiency of an Ocean Power Plant?

As described in the text, a power plant can take advantage of the temperature difference between warm water on the surface of the ocean and the cooler water found at greater depths. A typical surface temperature in the tropics is 25°C, and deep water can be 5°C. What is the Carnot efficiency for a heat engine with this temperature difference?

$$\begin{aligned} T_H &= 25^\circ\text{C} & e &= \frac{T_H - T_C}{T_H} \\ &= 298 \text{ K} & &= \frac{298 \text{ K} - 278 \text{ K}}{298 \text{ K}} \\ T_C &= 5^\circ\text{C} & &= \frac{20 \text{ K}}{298 \text{ K}} \\ &= 278 \text{ K} & &= \mathbf{0.067 (6.7\%)} \\ e &= ? & & \end{aligned}$$

scenario. Although the efficiency is low (6.7% in this case), so is the cost of water warmed by the sun. It still may be economically feasible to produce power in this manner.

The sun is an energy source with enormous potential for development if the costs become competitive. The temperatures that can be achieved with solar power depend on the type of collection system used. The ordinary flat-plate collector achieves relatively low temperatures of only 50°C to 100°C, but concentrating collectors that use mirrors or lenses to focus the sunlight provide much higher temperatures. Figure 11.18 shows a solar power plant in Spain, where an array of mirrors focuses sunlight on a boiler on a central tower. The temperatures generated are comparable to those of fossil-fuel plants, so similar steam turbines can be used.

Wind energy and wave energy are other alternatives to fossil fuels, but they do not involve heat engines. Both are, in a sense, converted forms of solar energy. The sun heats different parts of the Earth at different rates, and the temperature and pressure differences that result create the wind. Wind, in turn, is the primary factor in generating ocean waves. Because air



**Figure 11.18** At a solar thermal power plant near Seville, Spain, high temperatures are achieved by focusing sunlight from a large array of mirrors onto a boiler located at the top of the tower.

Lubri/Getty Images



has mass (see chapter 9), when it moves it has kinetic energy. Some portion of that kinetic energy can be transformed into mechanical or electrical energy by wind turbines. Windmills have long been used for pumping water on farms and for other applications. The kinetic energy in waves can also be harnessed, as described in everyday phenomenon box 15.1.

In recent years, both solar energy and wind have become competitive for generating electric power. Wind turbines have been showing up in many places where steady winds are frequent, such as ridge tops, plains, and near ocean beaches. Solar power is now being generated by photovoltaic panels placed on building roofs or in large arrays in places with lots of sun exposure. Photovoltaic cells are semiconductor devices that convert solar energy directly to electric power. Both wind and solar energy are intermittent sources, though, and must be backed by storage batteries or by steady energy-power sources.

### High-grade and low-grade heat

The temperature makes a big difference in how much useful work can be extracted from heat. The second law of thermodynamics and the related Carnot efficiency define the limits. What effects do these factors have on our national energy policies and our day-to-day use of energy?

Clearly, heat at temperatures around 500°C or higher is much more useful for running heat engines and producing mechanical work or electrical energy than heat at lower temperatures. Heat at these high temperatures is sometimes called **high-grade heat** because of its potential for producing work. Even then, only 50% or less of the heat can actually be converted to work.

Heat at lower temperatures can produce work but with considerably lower efficiency. Heat at temperatures around 100°C or lower is generally called **low-grade heat**. Low-grade heat is better used for purposes like heating homes and buildings (space heating). Space and water heating are the optimal uses for heat collected by flat-plate solar collectors, and even from geothermal sources, if they are near enough to buildings that need heat. Geothermal heat is used for space heating in Klamath Falls, Oregon, as well as in certain other parts of the world where conditions are favorable.

Much low-grade heat, such as the low-temperature heat released from power plants, goes to waste simply because it is not economical to transport it to places where space heating may be needed. Nuclear power plants, for example, are not usually built in populated areas. There are other possible uses of low-grade heat, such as in agriculture or aquaculture, but we have not gone far in developing such uses.

The main advantage of electrical energy is that it can be easily transported through power lines to users far from the point of generation. Electrical energy can also be readily converted to mechanical work by electric motors. Electric motors operate at efficiencies of 90% or greater, because they are *not* heat engines. The efficiency involved in producing the electrical power in the first place, of course, may have been considerably lower.

Electrical energy can also be converted back to heat if desired. Electricity is used for space heating in regions like the Pacific Northwest, where electric power has been relatively cheap because of the extensive hydroelectric resources on the Columbia River and its tributaries. The development of these resources has been subsidized by the federal government. Low prices encourage the use of a high-grade form of energy for purposes that might be just as well served by lower-grade sources.

Energy has been relatively cheap in the United States and in many other parts of the world. Continued economic development and the depletion of fossil-fuel resources will gradually change this picture. As scarcity occurs, questions of the optimal uses of energy resources will become critical. Wise decisions will depend on the participation of an informed, scientifically literate citizenry.

Thermal power plants use heat engines—steam turbines—to generate electric power. These engines are limited by the Carnot efficiency, which depends on input and output temperatures. The best that can be achieved is the 50% or so efficiency of fossil-fuel plants. The temperatures that can be obtained with other energy resources dictate the best way of using these resources. Lower temperatures are more suitable for space heating and similar uses than for power generation. The laws of thermodynamics set limits on power generation.

### Debatable Issue

Environmentalists have opposed the development of large solar-energy power plants in some locations for fear of damage to fragile desert ecosystems. On the other hand, desert locations are often attractive sites because of low land costs and little cloud interference. Should the environmental concerns be put aside in the interest of reducing our reliance on fossil fuels?

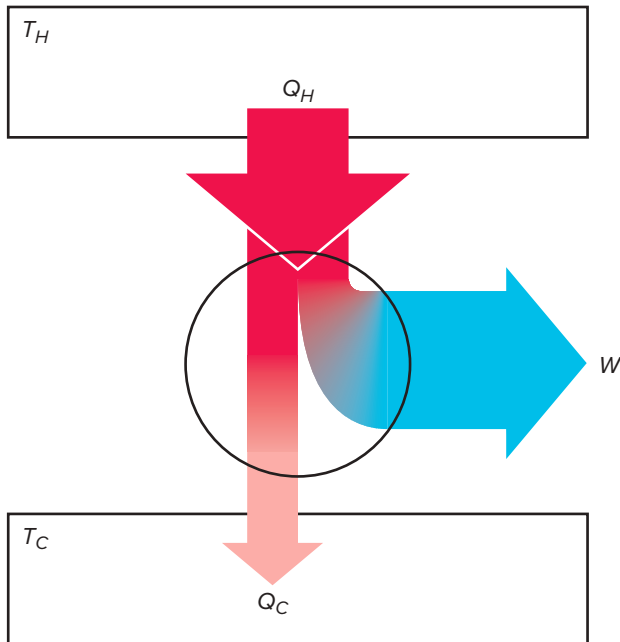
## 11.5 Perpetual Motion and Energy Frauds

The idea of perpetual motion has long fascinated inventors. The lure of inventing an engine that could run without fuel or from a plentiful source such as water is like finding gold. If such an engine could be developed and patented, the inventor would become even richer than if he or she had discovered gold.

Is such an engine possible? The laws of thermodynamics impose some limits. Because these laws are consistent with everything that physicists know about energy and engines, any claim that violates the laws of thermodynamics should be suspect. We can analyze claims of perpetual motion or miracle engines by testing to see if they violate either the first or the second law of thermodynamics.

### Perpetual-motion machines of the first kind

A proposed engine or machine that violates the first law of thermodynamics is called a **perpetual-motion machine of the first kind**. Because the first law of thermodynamics



**Figure 11.19** A perpetual-motion machine of the first kind. The energy output exceeds the input, and therefore the machine violates the first law of thermodynamics.

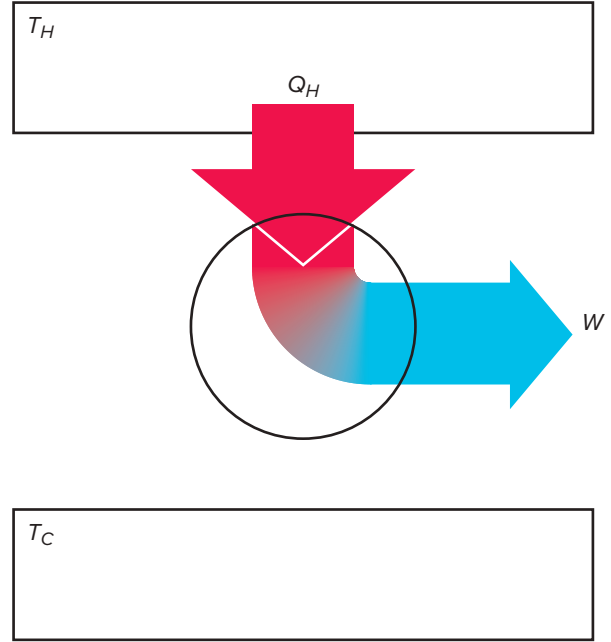
involves conservation of energy, a perpetual-motion machine of the first kind is one that puts out more energy as work or heat than it takes in. If the machine or engine is operating in a continuous cycle, the internal energy must return to its initial value, and the energy output of the engine must equal its energy input, as we have already seen.

In figure 11.19, the total magnitude of the work and heat output is greater than the magnitude of the heat input (as represented by the widths of the arrows). This could only happen if there were some source of energy, such as a battery, within the engine itself. If this were so, the energy in the battery would gradually be depleted, and the internal energy of the engine would decrease. The engine could not run indefinitely.

The fact that physicists reject such engines as impossible does not keep inventors from proposing them. From time to time, claims appear in newspapers and other popular media of engines that can run indefinitely fueled only by a gallon of water or a minuscule quantity of gasoline. Given the sometimes high price of gasoline, such claims have an obvious appeal and often attract investors and other interest. With your knowledge of physics, though, you could ask the inventor some simple questions: Where is the energy coming from? How can the machine put more energy out than went in?

### What is a perpetual-motion machine of the second kind?

Engines that would violate the second law of thermodynamics without violating the first law often are a little more subtle. Their inventors have learned how to answer the questions in



**Figure 11.20** A perpetual-motion machine of the second kind. Heat is extracted from a reservoir at a single temperature and converted completely to work, thus violating the second law of thermodynamics.

the previous section. They have a source of energy—perhaps they plan to extract heat from the atmosphere or the ocean. These claims must be evaluated in terms of the second law of thermodynamics. If the second law is violated, the inventor has proposed a **perpetual-motion machine of the second kind** (fig. 11.20).

The second law states that it is not possible to take heat from a reservoir at a single temperature and convert it completely to work. We must have a lower-temperature reservoir available, and some heat must be released into that reservoir. In addition, even if we have a lower-temperature reservoir, the efficiency of any engine running between the two reservoirs will be quite low if the temperature difference between the reservoirs is not great. Any claim of efficiency greater than the Carnot efficiency (for the available temperature difference) also violates the second law of thermodynamics.

The laws of thermodynamics are useful in evaluating an inventor's claims, and they guide our attempts to build better engines and to use energy more efficiently. Better engines can and will be developed, and their inventors may indeed be enriched in the process. A host of possibilities exist that involve relatively low-grade energy sources or other special circumstances. Engineers and scientists are also working on developing materials and innovative designs for engines that might use even higher temperatures than are common in today's fossil-fuel plants. These efforts do not violate the laws of thermodynamics.

Most physics departments receive inquiries from local inventors seeking endorsement or help with their schemes for producing or using energy. The inventors are often sincere and sometimes quite well informed. Occasionally, their ideas

## Everyday Phenomenon

## Box 11.2

**A Productive Pond**

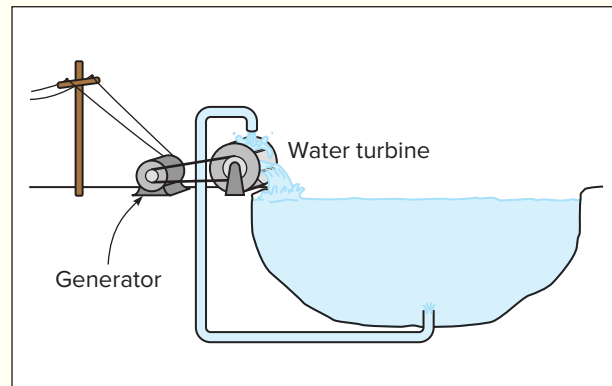
**The Situation.** A local farmer had an idea for generating electricity on his farm. The farmer had a pond he thought could be used to run a water wheel to power an electric generator, as shown in the drawing.

The sketch showed a drain pipe at the bottom of the pond. The farmer was aware that water would flow down such a drain with considerable velocity. His plan was to direct water through a pipe to the side of the pond and then up above the pond level, where it would flow onto a water wheel, powering the generator. The water would return to the pond after leaving the water wheel, so there would be no need to replenish the water supply, except to replace water lost to evaporation or seepage.

How would you advise the farmer? Will this plan work? Does it represent a perpetual-motion machine and, if so, of what kind?

**The Analysis.** Just by looking at the overall result, we see that work is being obtained to turn the generator without the input of any energy in the form of heat or work. Because the pond returns to its initial state (with the same internal energy), the first law of thermodynamics (the principle of conservation of energy) is violated by the proposal. The farmer's plan is a perpetual-motion machine of the first kind.

If we look at the mechanics in more detail, we see that the water will indeed gain kinetic energy as it flows down the drain. This gain in kinetic energy comes at the expense of a loss in potential energy as the pond level is lowered. Directing the water upward causes it to regain potential energy at the expense of kinetic energy: It will slow down. If there are no losses due to



A sketch of the farmer's plan for obtaining electric power from his pond. Which law of thermodynamics does he propose to violate?

friction, its velocity should reach zero at the point where it reaches the original level of the pond.

In an initial surge when the valve is opened, the water might overshoot the original pond level, but water cannot be raised above this level in a continuous process. Eventually, the water in the vertical pipe will reach the same level as the pond, and no water will flow. The proposal will not work.

Although the farmer was an educated and intelligent person, theoretical arguments could not convince him that the idea would not work. However, he could have tested the idea by making a small-scale model before investing any money in plumbing his pond. Such prototypes can be more convincing than theoretical arguments.

have merit, although they are often based on misunderstandings of the laws of thermodynamics (see everyday phenomenon box 11.2). Unfortunately, it is often hard to persuade inventors that their ideas will not work, even when they involve clear violations of the laws of thermodynamics.

Other cases are more clearly the work of charlatans. Inventors who begin with good intentions sometimes discover that their ideas attract money from eager investors even when the invention fails to work. Some inventors have managed to raise several million dollars for the design and testing of prototype engines. Somehow, the engines are never quite finished, or tests are inconclusive and more money is needed to continue the work. The inventors, in the meantime, live quite well and find that promoting their inventions is more lucrative than actually building and testing them.

Investors beware. There are no known circumstances that violate the laws of thermodynamics. The failure of repeated attempts to violate them reinforces physicists' belief in their

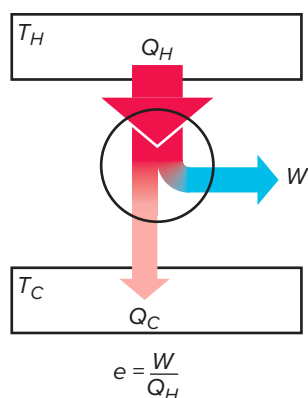
validity. The laws cannot be proved, but their proven ability to accurately describe experimental results gives physicists confidence that they will continue to be useful indicators of what is possible. A basic knowledge of the first and second laws of thermodynamics might save you money someday.

A perpetual-motion machine of the first kind violates the first law of thermodynamics because more work is obtained than energy put in. A perpetual-motion machine of the second kind violates the second law of thermodynamics either by converting heat completely to work or by claiming an efficiency greater than the Carnot efficiency. Physicists do not believe that either of these options is possible, but inventors keep trying and investors keep wasting money on such schemes. The laws of thermodynamics place limits on what can be done and guide attempts to build better engines.

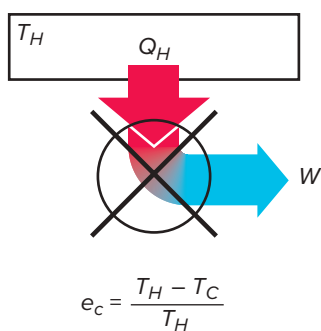
## Summary

Attempts to build better steam engines led to a more general analysis of heat engines and, ultimately, to a statement of the second law of thermodynamics. The second law explains the workings of heat engines and refrigerators and the concept of entropy. An understanding of the laws of thermodynamics is crucial to making wise energy choices and policy decisions.

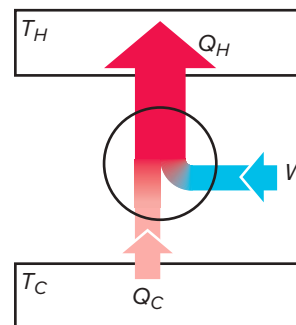
**1 Heat engines.** A heat engine is any device that takes in heat from a high-temperature source and converts some of this heat to useful mechanical work. In the process, some heat is always released at lower temperatures into the environment. The efficiency of a heat engine is defined as the work output divided by the heat input.



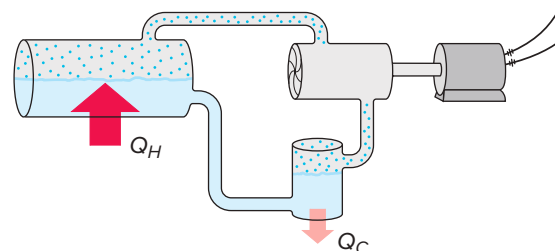
**2 The second law of thermodynamics.** The Kelvin statement of the second law says that it is not possible for an engine, working in a continuous cycle, to take in heat at a single temperature and convert that heat completely to work. The maximum possible efficiency for any engine operating between two given temperatures is that of a Carnot engine. It is always less than 1, or 100%.



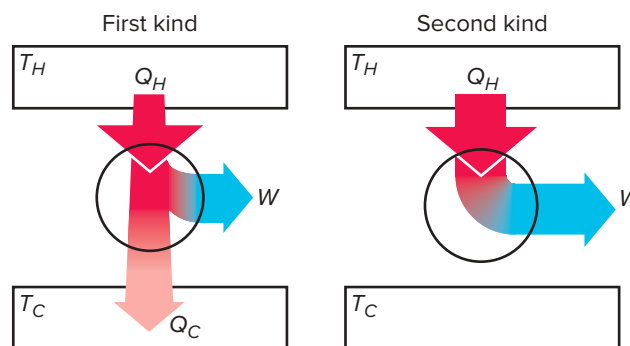
**3 Refrigerators, heat pumps, and entropy.** A heat pump or refrigerator is a heat engine run in reverse—it uses work to move heat from a low-temperature body to a hotter one. The Clausius statement of the second law says that heat will not flow spontaneously from a colder to a hotter body. Entropy can be thought of as a measure of the disorder of a system. This disorder is responsible for the limitations expressed in the second law. Irreversible processes always increase the entropy of the universe.



**4 Thermal power plants and energy resources.** Power plants that use heat generated from coal, oil, natural gas, nuclear fuels, geothermal sources, or the sun to produce electrical energy are all examples of thermal power plants. Their efficiency cannot be greater than the Carnot efficiency, so high input temperatures are desirable.



**5 Perpetual motion and energy frauds.** Any proposed device that would violate the first law of thermodynamics is called a perpetual-motion machine of the first kind. One that would violate the second law, but not the first, is called a perpetual-motion machine of the second kind. Neither will work.



If you have difficulty with the exercises, first try the practice problems in Connect. They give detailed solutions that will increase your problem-solving skills.

## Key Terms

Heat engine, 216	Second law of thermodynamics, 221	Low-grade heat, 228
Efficiency, 217	Heat pump, 223	Perpetual-motion machine of the first kind, 228
Reversible, 220	Entropy, 225	Perpetual-motion machine of the second kind, 229
Carnot engine, 220	Thermal power plant, 225	
Carnot efficiency, 221	High-grade heat, 228	

## Conceptual Questions

\* = more open-ended questions, requiring lengthier responses, suitable for group discussion

Q = sample responses are available in appendix D

Q = sample responses are available in Connect

- Q1. Which of these types of motors or engines are heat engines?
- an automobile engine
  - an electric motor
  - a steam turbine
- Explain your reasons for classifying or not classifying each of these as a heat engine.

- Q2. Could a simple machine such as a lever, a pulley system, or a hydraulic jack be considered a heat engine? Explain.

- Q3. In applying the first law of thermodynamics to a heat engine, why is the change in the internal energy of the engine assumed to be zero? Explain.

- Q4. Is the total amount of heat released by a heat engine to the low-temperature reservoir in one cycle ever greater than the amount of heat taken in from the high-temperature reservoir in one cycle? Explain.

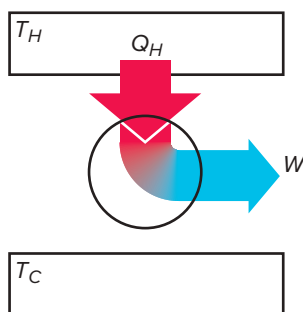
- Q5. From the perspective of the first law of thermodynamics, is it possible for a heat engine to have an efficiency greater than 1? Explain.

- Q6. Which motor in a hybrid vehicle—the electric or gasoline—is primarily used in city driving? Explain. (See everyday phenomenon box 11.1.)

- Q7. Why can a hybrid automobile get away with a small gasoline engine yet still have good acceleration capability? Explain. (See everyday phenomenon box 11.1.)

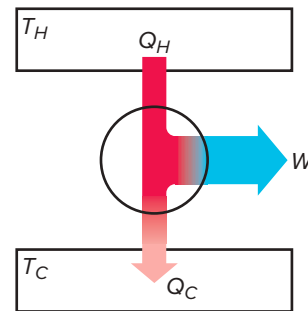
- Q8. Which law of thermodynamics requires the work output of the engine to equal the difference in the quantities of heat taken in and released by the engine? Explain.

- Q9. Is it possible for a heat engine to operate as shown in the diagram? Explain, using the laws of thermodynamics.



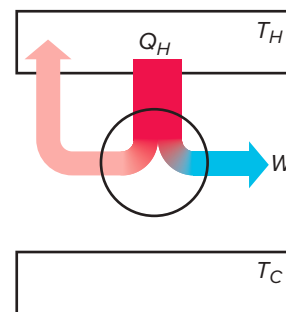
Q9 Diagram

- Q10. Is it possible for a heat engine to operate as shown in the diagram? Explain, using the laws of thermodynamics.



Q10 Diagram

- Q11. Is it possible for a heat engine to operate as shown in the diagram? Explain, using the laws of thermodynamics.



Q11 Diagram

- Q12. Is it possible for the efficiency of a heat engine to equal 1? Explain.

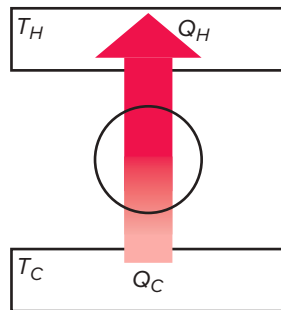
- Q13. Can a Carnot engine operate in an irreversible manner? Explain.

- Q14. Does a gasoline-burning automobile engine operate in a reversible manner? Explain.

- Q15. Which would have the greater efficiency—a Carnot engine operating between the temperatures of 400°C and 300°C, or one operating between the temperatures of 400 K and 300 K? Explain.

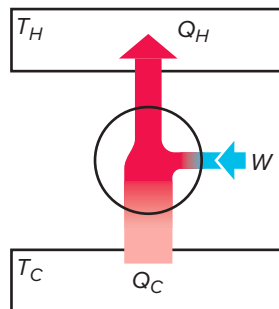
- \*Q16. If we wanted to increase the efficiency of a Carnot engine, would it be more effective to raise the temperature of the high-temperature reservoir by 50°C or lower the temperature of the low-temperature reservoir by 50°C? Explain.

- Q17. Is a heat pump the same thing as a heat engine? Explain.
- Q18.** Is a heat pump essentially the same thing as a refrigerator? Explain.
- Q19. When a heat pump is used to heat a building, where does the heat come from? Explain.
- Q20. Is it possible to cool a closed room by leaving the door of a refrigerator open in the room? Explain.
- Q21.** Is it ever possible to move heat from a cooler to a warmer temperature? Explain.
- Q22. Is it possible for a heat pump to operate as shown in the diagram? Explain, using the laws of thermodynamics.



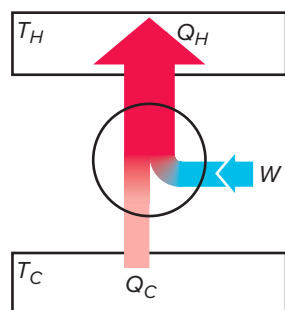
**Q22 Diagram**

- Q23. Is it possible for a heat pump to operate as shown in the diagram? Explain, using the laws of thermodynamics.



**Q23 Diagram**

- Q24.** Is it possible for a heat pump to operate as shown in the diagram? Explain, using the laws of thermodynamics.



**Q24 Diagram**

- Q25. Which has the higher entropy, a deck of cards in which the cards are organized by suit or a shuffled deck of cards? Explain.
- Q26. A hot cup of coffee is allowed to cool down, thus warming its surroundings. Does the entropy of the universe increase in this process? Explain.
- \*Q27.** When a substance freezes, the molecules become more organized and the entropy decreases. Does this involve a violation of the entropy statement of the second law of thermodynamics? Explain.
- Q28. Which would normally have the greater thermal efficiency, a coal-fired power plant or a geothermal power plant? Explain.
- Q29. In what ways is a nuclear power plant similar to a coal-fired plant? Explain.
- Q30.** What is the distinction between high-grade heat and low-grade heat? Explain.
- \*Q31.** Electric motors convert electrical energy to mechanical work at a much higher efficiency than gasoline engines can convert heat to work. Why might it not make sense, then, to run all of our vehicles on electric power? Where does the electric power originate? Explain.
- Q32. Is heat that is obtained from a flat-plate solar collector best used for running a heat engine or for space heating? Explain.
- Q33.** Is an automobile engine a perpetual-motion machine? Explain.
- Q34. An engineer proposes a power plant that will extract heat from warm surface water in the ocean, convert some of it to work, and release the remaining heat into cooler water at greater depths. Is this a perpetual-motion machine and, if so, what kind? Explain.
- Q35. An engineer proposes a device that will extract heat from the atmosphere, convert some of it to work, and release the remaining heat back into the atmosphere at the same temperature as the input heat. Is this a perpetual-motion machine and, if so, what kind? Explain.
- Q36.** The water draining from the bottom of the pond discussed in everyday phenomenon box 11.2 initially gains kinetic energy. How much of this kinetic energy is converted to potential energy by the time the water has reached the original level of the pond?
- Q37. Is the first law of thermodynamics violated by the pond-power system proposed by the farmer in everyday phenomenon box 11.2? Explain.

## Exercises

- E1. In one cycle, a heat engine takes in 1200 J of heat from a high-temperature reservoir, releases 756 J of heat to a lower-temperature reservoir, and does 444 J of work. What is its efficiency?
- E2. A heat engine with an efficiency of 28% does 700 J of work in each cycle. How much heat must be supplied from the high-temperature source in each cycle?
- E3. In one cycle, a heat engine takes in 800 J of heat from a high-temperature reservoir and releases 472 J of heat to a lower-temperature reservoir.
- How much work is done by the engine in each cycle?
  - What is its efficiency?
- E4. A heat engine with an efficiency of 35% takes in 1100 J of heat from the high-temperature reservoir in each cycle.
- How much work does the engine do in each cycle?
  - How much heat is released to the low-temperature reservoir?
- E5. In one cycle, a heat engine does 700 J of work and releases 1100 J of heat to a lower-temperature reservoir.
- How much heat does it take in from the higher-temperature reservoir?
  - What is the efficiency of the engine?
- E6. A Carnot engine takes in heat at a temperature of 780 K and releases heat to a reservoir at a temperature of 360 K. What is its efficiency?
- E7. A Carnot engine takes in heat from a reservoir at 500°C and releases heat to a lower-temperature reservoir at 180°C. What is its efficiency?
- E8. A Carnot engine operates between temperatures of 800 K and 560 K and does 147 J of work in each cycle.
- What is its efficiency?
  - How much heat does it take in from the higher-temperature reservoir in each cycle?
- E9. A heat pump takes in 450 J of heat from a low-temperature reservoir in each cycle and uses 200 J of work per cycle to move the heat to a higher-temperature reservoir. How much heat is released to the higher-temperature reservoir in each cycle?
- E10. In each cycle of its operation, a refrigerator removes 24 J of heat from the inside of the refrigerator and releases 56 J of heat into the room. How much work per cycle is required to operate this refrigerator?
- E11. A typical electric refrigerator (see fig. 11.9) has a power rating of 500 W, which is the rate (in J/s) at which electrical energy is supplied to do the work needed to remove heat from the refrigerator. If the refrigerator releases heat to the room at a rate of 800 W, at what rate (in watts) does it remove heat from the inside of the refrigerator?
- E12. A typical nuclear power plant delivers heat from the reactor to the turbines at a temperature of 720°C. If the turbines release heat at a temperature of 310°C, what is the maximum possible efficiency of these turbines?
- E13. An ocean thermal-energy power plant takes in warm surface water at a temperature of 21°C and releases heat at 10°C to cooler water drawn from deeper in the ocean. Is it possible for this power plant to operate at an efficiency of 5%? Justify your answer.
- E14. An engineer designs a heat engine using flat-plate solar collectors. The collectors deliver heat at 75°C, and the engine releases heat to the surroundings at 32°C. What is the maximum possible efficiency of this engine?

## Synthesis Problems

- SP1. Suppose that a typical automobile engine operates at an efficiency of 19%. One gallon of gasoline releases approximately 120 megajoules (MJ) of heat when it is burned. (A megajoule is a million joules.)
- Of the energy available in a gallon of gas, how much energy can be used to do useful work in moving the automobile and running its accessories?
  - How much heat per gallon is released to the environment in the exhaust gases and via the radiator?
  - If the car is moving at constant speed, how is the work output of the engine used?
  - Would you expect the efficiency of the engine to be greater on a very hot day or on a cold day? Explain. (There may be competing effects at work.)
- SP2. Suppose that a certain Carnot engine operates between the temperatures of 510°C and 240°C and produces 70 J of work in each complete cycle.
- What is the efficiency of this engine?
  - How much heat does it take in from the 510°C reservoir in each cycle?
  - How much heat is released to the 240°C reservoir in each cycle?
  - What is the change, if any, in the internal energy of the engine in each cycle?
- SP3. A Carnot engine operating in reverse as a heat pump moves heat from a cold reservoir at 7°C to a warmer one at 22°C.
- What is the efficiency of a Carnot engine operating between these two temperatures?
  - If the Carnot heat pump releases 250 J of heat into the higher-temperature reservoir in each cycle, how much work must be provided in each cycle?
  - How much heat is removed from the 7°C reservoir in each cycle?
  - The performance of a refrigerator or heat pump is described by a “coefficient of performance,” defined as  $K = Q_c/W$ . What is the coefficient of performance for our Carnot heat pump?
  - Are the temperatures used in this example appropriate to the application of a heat pump for home heating? Explain.

- SP4. In section 11.3, we showed that a violation of the Clausius statement of the second law of thermodynamics is a violation of the Kelvin statement. Develop an argument to show that the reverse is also true: A violation of the Kelvin statement is a violation of the Clausius statement.
- SP5. Suppose that an oil-fired power plant is designed to produce 125 megawatts (MW) of electric power. The turbine operates between temperatures of  $740^{\circ}\text{C}$  and  $380^{\circ}\text{C}$  and has an efficiency that is 80% of the ideal Carnot efficiency for these temperatures.
- What is the Carnot efficiency for these temperatures?
  - What is the efficiency of the actual oil-fired turbines?
  - How many kilowatt-hours ( $\text{kW}\cdot\text{h}$ ) of electrical energy does the plant generate in 1 h? (The kilowatt-hour is an energy unit equal to 1 kW of power multiplied by 1 h.)
  - How many kilowatt-hours of heat must be obtained from the oil in each hour?
  - If one barrel of oil yields  $1700\text{ kW}\cdot\text{h}$  of heat, how much oil is used by the plant each hour?

## Home Experiments and Observations

- HE1. If there is a refrigerator handy in your residence hall or home, study the construction of the refrigerator to make these observations:
- What energy source (gas or electricity) provides the work necessary to remove the heat? Can you find a power rating somewhere on the refrigerator?
  - Where are the heat-exchange coils used to release heat into the room? (They are usually on the back of the refrigerator, often near the bottom.)
  - Use a thermometer to determine the temperatures inside the refrigerator, inside the freezer compartment, near the heat-exchange coils outside, and in the room at some distance from the refrigerator. You should take measurements at different times to see how much these temperatures vary.
- HE2. Find a local car dealer who sells hybrid automobiles. (Honda and Toyota are currently the best bets.) Collect literature describing the specifications for its hybrid vehicle, as well as for other vehicles of similar size. (This information may also be obtained on the Internet.)
- Compare the gasoline engine size, horsepower, and estimated gas mileage for the hybrid vehicle and the standard vehicle of similar size.
  - What are the voltage and current ratings for the batteries in hybrid and standard vehicles?
  - What trade-offs do you see in purchasing the hybrid versus the standard vehicle of similar size?
- HE3. What types of power plants are used to generate electricity in your area? Do they employ heat engines, and if so, what is the source of heat? Are cooling towers or other cooling structures used to release waste heat into the atmosphere? (Your local utility company should be able to provide such information.)





# UNIT 3

## Electricity and Magnetism

No area of physics has had a greater impact on the way we live than the study of electricity and magnetism. Using electricity and electronic devices has become second nature to us now but would have been hard to imagine two hundred years ago. The invention and design of television sets, microwave ovens, computers, cell phones, and thousands of other familiar appliances and devices have required an understanding of the basic principles of electricity and magnetism.

Although the effects of magnets and static electricity had been known for a long time, our basic knowledge of electricity and magnetism is mainly a product of the nineteenth century. A key invention at the turn of that century opened the door to these developments. In 1800, Italian scientist Alessandro Volta (1745–1827) invented the battery. Volta's invention grew out of the work of an Italian physician, Luigi Galvani (1737–1798), who had discovered effects that he called *animal electricity*. Galvani found that he could produce electrical effects by probing a frog's leg with metal scalpels.

Volta discovered that the frog was not necessary. Two different kinds of metal separated by a suitable chemical solution were sufficient to produce many of the electrical effects observed by Galvani. Volta's *voltaic piles*, which consisted of alternating plates of copper and zinc separated by paper impregnated with a chemical solution, were capable of producing sustained electric currents. As often happens, this new device made many new experiments and investigations possible.

The invention of the battery led to the discovery of the magnetic effects of electric currents by Hans Christian



Perry Mastrovito/Digital Stock/CORBIS

Oersted (1777–1851) in 1820. Oersted's discovery made a formal connection between electricity and magnetism, leading to the modern term *electromagnetism*. Electromagnetism was the hot area of research for physicists during the 1820s and 1830s, and key advances were made by Ampère, Faraday, Ohm, and Weber. In 1865, Scottish physicist James Clerk Maxwell (1831–1879) published a comprehensive theory of electric and magnetic fields that brought together the insights of many of these other scientists. Maxwell invented the concepts of electric and magnetic fields, ideas that proved to be tremendously productive.

Electromagnetism is still an active area of research. Its ramifications are important in radio and television, computers, communications, and other areas of technology. Despite this importance, the invisibility of the underlying phenomena makes the subject of electromagnetism seem abstract and mysterious to many people. The basic ideas are not difficult, though, and can be understood by carefully examining familiar phenomena.



# CHAPTER 12

Balazs Kovacs/Getty Images

## Electrostatic Phenomena

---

### Chapter Overview

The main purpose of this chapter is to describe and explain the electrostatic force. We also investigate concepts such as electric field and electric potential. These concepts will be made more vivid by describing and interpreting some simple experiments. Experimentation can lead to a better understanding of electric charge, the distinction between conductors and insulators, and many other ideas.

### Chapter Outline

- 1 Effects of electric charge.** What is electric charge? How is it involved in the electrostatic force? How do objects acquire charge?
- 2 Conductors and insulators.** How do insulating materials and conducting materials differ? How can we test this difference? How does charging by induction work? Why are bits of paper or Styrofoam attracted to charged objects?
- 3 The electrostatic force: Coulomb's law.** What is the electrostatic force described by Coulomb's law? How does it depend on charge and distance? How is it similar to (and different from) the gravitational force?
- 4 The electric field.** How is the concept of electric field defined? Why is it useful? How can we use electric field lines to help us visualize electrostatic effects?
- 5 Electric potential.** How is the concept of electrostatic potential defined? How is it related to potential energy? What is voltage? How are the concepts of electric field and electric potential related?

**M**ost of us have had the experience of running a comb through our hair on a dry winter day and hearing a crackling sound or, if the room is dark enough, even seeing sparks. Depending on the length and looseness of the hair, strands of it may have stood on end, as in figure 12.1. This phenomenon is intriguing but also annoying. You often have to wet the comb to get your hair to behave.

What is happening? Some force seems to be at work, causing the individual hairs to repel one another. You would probably identify that force as an electrostatic force, or at least you might say that static electricity is the cause of your unruly hair. To name a phenomenon is not the same as explaining it, though. Why does static electricity occur under these conditions, and what is the force in question?

Hair-and-comb fireworks are just one example of electrostatic phenomena that are part of our everyday experience. Why does a piece of plastic refuse to leave your hand after you have peeled it off a package? Why do you get a slight shock after you walk across a carpeted floor and touch a light switch? The phenomena range from static cling and similar annoyances to dramatic displays of lightning in a big thunderstorm. They are familiar and yet, to many of us, mysterious.



**Figure 12.1** Hair sometimes seems to have a mind of its own when combed on a dry winter day. What causes the hairs to repel one another? *Bob Coyle/McGraw-Hill Education*

Despite its familiarity, many of us are surprisingly unaware of what static electricity is. People are often put off by a fear of electric shock as well as by the abstract nature of the subject. It need not be so. Many of the phenomena can be explained with ideas accessible to all of us.

## 12.1 Effects of Electric Charge

What do the hair-combing example and the other phenomena mentioned in the chapter introduction have in common? The comb passing through your hair, your shoes passing over the rug, and plastic being peeled from a box all involve different materials rubbing against one another. Perhaps this rubbing is the cause of the phenomena.

How can we test such an idea? One approach would be to collect different materials, rub them together in various combinations, and see what we generate in the way of sparks or other observable effects. Experiments like these could help to establish which combinations of materials are most effective in producing electrostatic crackles and pops. Of course, we would also need some consistent way of gauging the strength of these effects.

### What can we learn from experiments with pith balls?

A common way of demonstrating electrostatic effects is to rub plastic or glass rods with different furs or fabrics. If we rub a plastic or hard rubber rod with a piece of cat fur, for example, we can see the hairs on the fur standing out and snapping at one another. Like the hair-combing fireworks, these effects are most striking on a dry winter day when little moisture is in the air. Another piece of equipment often used in these demonstrations is a small stand to which two pith balls are attached by threads (fig. 12.2). Pith balls are small wads of dry, paperlike

material light enough to be strongly influenced by electrostatic forces.

An interesting sequence of events happens when a plastic rod, vigorously rubbed with cat fur on a dry day, is brought near the pith balls. At first, the pith balls are attracted to the rod like bits of iron to a magnet. After contacting the rod,



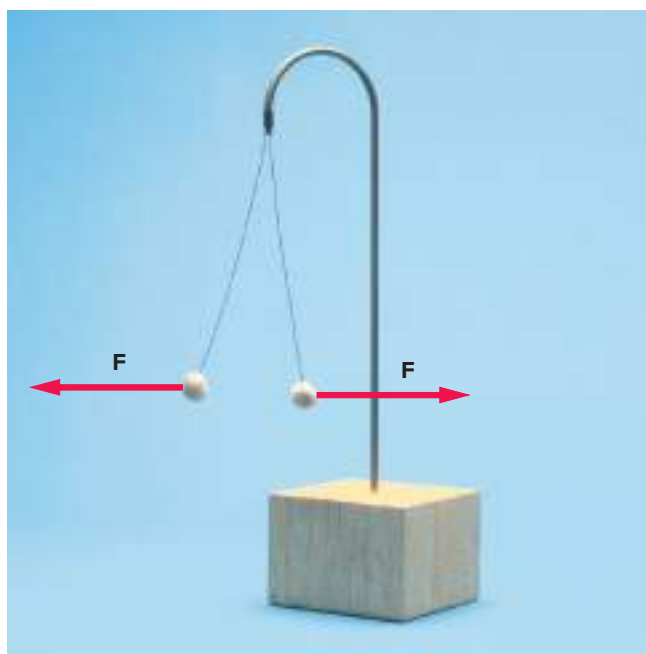
**Figure 12.2** Pith balls suspended from a small stand are attracted to a charged plastic rod. *James Ballard/McGraw-Hill Education*

and perhaps sticking to it for a few seconds, the pith balls dance away from the rod. They are repelled by the rod at this point as well as by each other. The threads supporting the pith balls then form an angle to the vertical, as in figure 12.3, rather than hanging straight down.

How can we explain what has happened? A repulsive force must be acting between the two pith balls after they have been in contact with the rod. We might imagine that the balls have received something (call it **electric charge**) from the rod that is responsible for the force we observe. This charge, whatever it is, was somehow generated by rubbing the rod with the cat fur. The force exerted by one stationary charge on another is called the **electrostatic force**.

We can observe further changes if we rub a glass rod with a piece of synthetic fabric, such as nylon. If the glass rod is brought near the pith balls that have been charged by the plastic rod, the pith balls are now attracted to the glass rod. They are still repelled by the plastic rod. If we allow the pith balls to touch the glass rod, they repeat the sequence of events we observed earlier with the plastic rod. At first, they are attracted and stick briefly to the rod. Then, they dance away and are repelled by the rod and by each other. If we bring the plastic rod near, we now find that the balls are attracted to the plastic rod.

These observations complicate the picture somewhat. Apparently, there are at least two types of charge: one generated by rubbing a plastic rod with fur and another generated by rubbing a glass rod with nylon. Could there be more kinds of charge? Further experiments with different materials would indicate that these two types are all we need to explain the



**Figure 12.3** Once the pith balls have moved away from the rod, they also repel each other, indicating the presence of a repulsive force. James Ballard/McGraw-Hill Education

effects. Other charged objects will cause either an attraction or a repulsion with the two types of charge already identified and can be placed in one of these two categories.

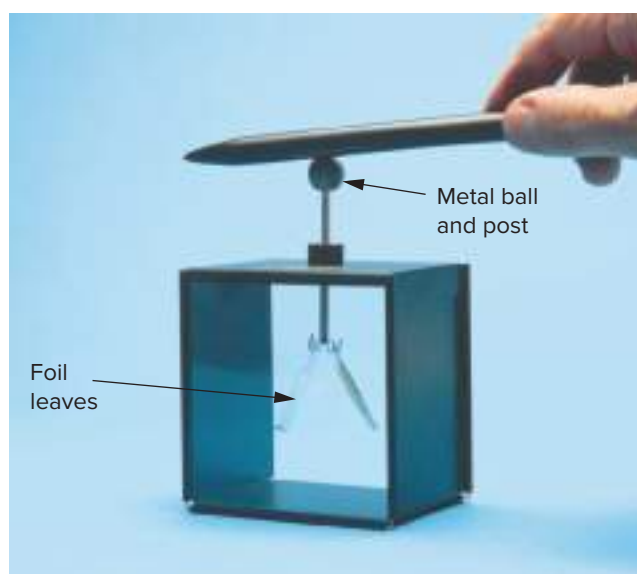
### What is an electroscope?

A simple *electroscope* consists of two leaves of thin, metallic foil suspended face-to-face from a metal hook (fig. 12.4). At one time, gold foil was used, but aluminized Mylar is now preferred. The leaves are connected by the hook to a metal ball protruding from the top of the instrument. The foil leaves are protected from air currents and other disturbances by a glass-walled container.

If the foil leaves are uncharged, they will hang straight down. If we bring a charged rod in contact with the metal ball on the top, however, the leaves immediately spread apart. They will remain spread apart even after the rod is taken away, presumably because the leaves are now charged.

If any charged object is now brought near the metal ball, the electroscope shows what type of charge is on the object and gives a rough indication of how much charge is present. If an object with the same type of charge as the original rod is brought near the ball, the leaves will spread farther apart. An object with the opposite charge will make the leaves come closer together. A larger charge produces a larger effect.

Although less dramatic than the pith balls, the electroscope offers several advantages for detecting the type and strength of charge. First, the foil leaves do not dance around and become tangled together as pith balls often do. The metal ball on the electroscope offers a stationary point for testing other objects. Also, the distance the leaves move apart or come together when a charged object is brought near the ball gives a consistent indication of the strength of the charge.



**Figure 12.4** A simple electroscope consists of two metallic-foil leaves suspended from a metal post inside a glass-walled container. James Ballard/McGraw-Hill Education

An electroscope gives further information about the charging process. When we charge the plastic rod by rubbing it with the cat fur, the fur also is charged, but with a charge of the opposite type. We can verify this by bringing the fur close to the ball on the electroscope after the electroscope has been charged by the rod. When the fur approaches the metal ball, the leaves move closer together. They move farther apart when the rod approaches. Similar experiments show that the glass rod and the nylon fabric also acquire opposite types of charge when rubbed together. Example box 12.1 provides another example of charging by rubbing.

### Benjamin Franklin's single-fluid model

By the middle of the eighteenth century, it was well known that two types of charge produce electrostatic forces between charged objects. The forces are either attractive or repulsive, according to this simple rule:

Like charges repel each other, and unlike charges attract each other.

There was less agreement, however, on what to call these two types of charge. *Charge-produced-on-a-rubber-rod-when-rubbed-by-cat-fur* and *charge-produced-on-a-glass-rod-when-rubbed-with-silk* are unwieldy. *Positive* and *negative*, the names we now use, were introduced by American statesman and scientist Benjamin Franklin (1706–1790) around 1750. During the 1740s, Franklin had performed a

### Example Box 12.1

#### Sample Question: Carpet Fireworks

**Question:** Why do sparks fly when we shuffle across a carpet on a dry day and then touch a light switch?

**Answer:** Shuffling our feet on a carpet represents a rubbing process between two different materials. The soles of our shoes are often made of a rubberlike material and the carpet fibers are usually a synthetic fabric. The rubbing process creates a separation of charge similar to those we have been describing using rods and fabric. The charge that our shoes acquire can flow to other parts of our bodies, which are good conductors.

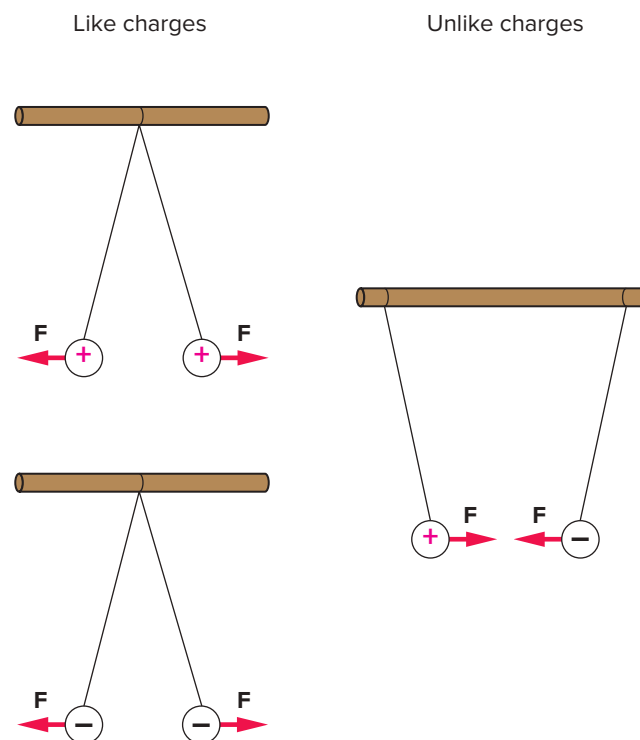
When we touch a light switch, the charge we have acquired discharges, producing the sparks. This is because, when properly wired, the switch is *grounded*. This means that the external parts of the switch are connected via wires and other conductors to the Earth, which serves as a large sink for charge. The excess charge on our bodies is discharged to ground via the switch.

series of experiments on static electricity like those we have described.

Franklin proposed that the facts, as they were known, could be explained by the action of a single fluid that was transferred from one object to another during charging. The charge acquired when a surplus of this fluid was gained was *positive* (+) and the charge associated with a shortage of this fluid was *negative* (–) (fig. 12.5). Which of these was which was not clear, because the fluid itself was invisible and not otherwise detectable. Franklin arbitrarily proposed that the charge on a glass rod when rubbed with silk (there were no synthetic fabrics then) be called positive.

Besides simplifying the names of the two types of charge, Franklin's model offered a picture of what might be happening during charging. In his model, two objects become oppositely charged because some *neutral* or stable amount of the invisible fluid is present in all objects, and rubbing objects together transfers some of this fluid from one object to the other. During rubbing, one object gains an excess of the fluid while the other experiences a shortage. Franklin's model was simpler than an earlier theory that had proposed two different substances for the two types of charge.

Franklin's model comes surprisingly close to our modern view of what takes place during charging. We now know that electrons are transferred between objects when they are rubbed together. **Electrons** are small, negatively charged particles present in all atoms and, therefore, in all materials. A negatively charged object has a surplus of electrons, and a



**Figure 12.5** Like charges repel, and unlike charges attract. The plus and minus signs were introduced in Franklin's single-fluid model.

positively charged object has a shortage of electrons. The atomic or chemical properties of materials dictate which way the electrons flow when objects are rubbed together.

Rubbing different materials together sometimes causes electric charge to move from one material to the other. This charge then produces attractive or repulsive electrostatic forces between objects. Like charges repel one another, and unlike charges attract one another. An electroscope consistently gauges the sign and strength of the charge present. Using Benjamin Franklin's labels, there are two types of charge: positive and negative. The positive and negative labels originally meant a surplus or shortage of an invisible fluid in Franklin's model, but we now know that negatively charged electrons are transferred during rubbing.

## 12.2 Conductors and Insulators

The experiments described in section 12.1 gave us some basic information about the electrostatic force. Different properties of materials are also important, however, in understanding the range of electrostatic phenomena. Why were the pith balls initially attracted to the rod, for example, even when they were not charged? Why are the leaves in the electroscope made of metal? The distinction between insulators and conductors is a big piece of the puzzle.

### How do insulators differ from conductors?

Suppose you touch the electroscope with a charged plastic or glass rod. The leaves repel each other. What happens if you then touch the metal ball on top of the electroscope with your finger? The leaves of the electroscope immediately droop straight down. You have *discharged* the electroscope by touching the ball with your finger (fig. 12.6).

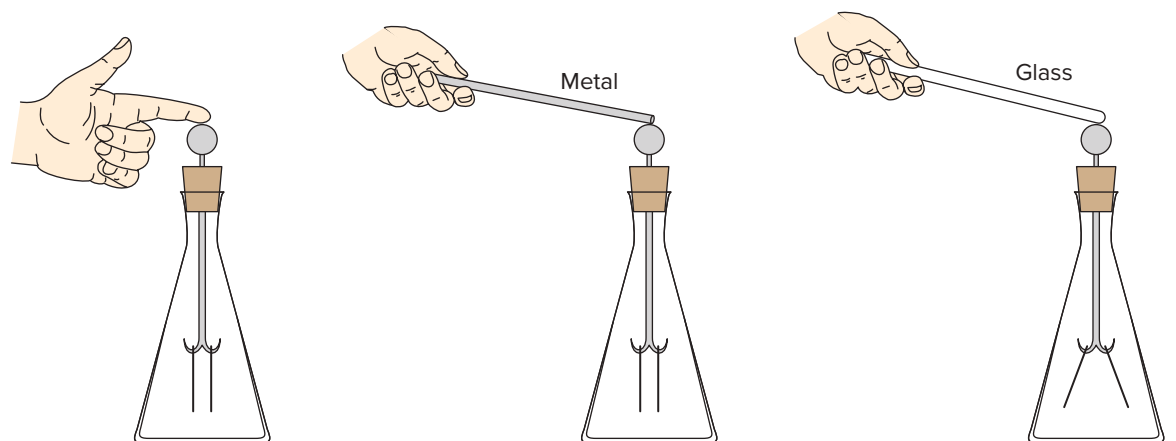
Suppose you charge up the electroscope again. Now, touch the metal ball on top with an uncharged rod made of plastic or glass. There is no effect on the leaves of the electroscope. If, however, you touch the ball with a handheld metal rod, the leaves immediately droop straight down. The electroscope is discharged.

How can we explain these observations? Apparently, both the metal rod and your finger allow charge to flow from the leaves of the electroscope to your body. Your body is a large neutral *sink* for charge. You can easily absorb the charge on the electroscope without much change in your overall charge. The plastic or glass rods, on the other hand, do not seem to permit the flow of charge from the electroscope to your body. The excess charge found on a rubber rod rubbed with cat fur is on the surface of the rod and easily transferred to other objects. The excess charge does not flow through the rubber to your hand, because rubber is a good insulator.

The metal rod and our bodies are examples of **conductors**, materials through which charge can flow readily. Plastic and glass are examples of **insulators**, materials that do not ordinarily permit the flow of charge. By performing similar experiments using the charged electroscope, we could test many other materials and would discover that all metals are good conductors, while glass, plastic, and most nonmetallic materials are good insulators. Table 12.1 lists some examples of insulating and conducting materials.

The difference in the ability of good conductors and good insulators to conduct electric charge is amazingly large. Charge flows much more readily through several miles of copper wire than it does through the few inches of ceramic material used as an insulator on electric transmission lines.

As we will see in chapter 18, these differences can be understood in terms of atomic structure. Metals, which are good conductors, have one to three loosely bound electrons outside of a more stable shell with tightly bound electrons.



**Figure 12.6** Touching the ball on top of a charged electroscope with either your finger or a metal rod causes the electroscope to discharge. Touching a charged electroscope with an uncharged glass rod produces no effect.

Table 12.1

Some Common Conductors, Insulators, and Semiconductors		
Conductors	Insulators	Semiconductors
Copper	Glass	Silicon
Silver	Plastic	Germanium
Iron	Ceramics	
Gold	Paper	
Salt solution	Oil	
Acids		

These loosely bound electrons are freer to roam through the body of the metal and can therefore more easily conduct electricity.

**Semiconductors** are materials that are intermediate between good conductors and good insulators. Silicon is probably the most familiar example. A wooden rod behaves like a semiconductor in discharging the electroscope. With the appropriate amount of moisture in the wood, the rod will cause a slow discharge of the electroscope.

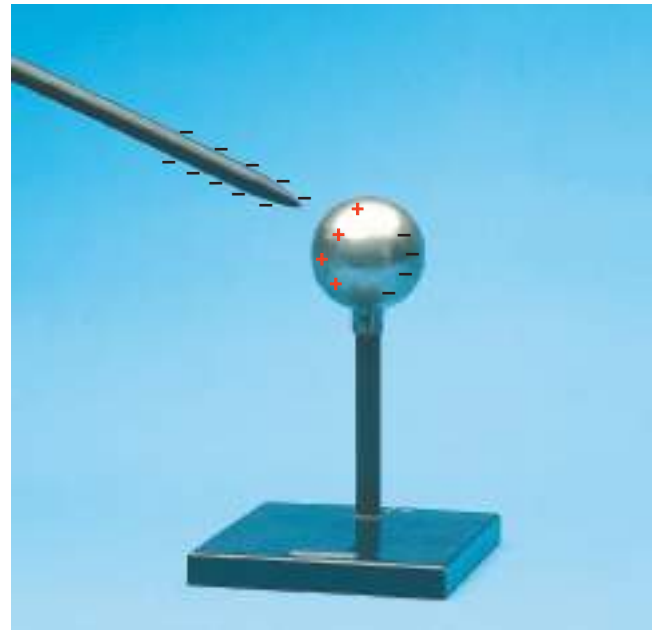
Although semiconductors are far less common than good conductors or good insulators, their importance to modern technology is enormous. The ability to control the level of conduction in these materials by mixing in small amounts of other substances has led to the development of miniaturized electronic devices such as transistors and integrated circuits. The entire computer revolution has relied on the use of these materials, mostly silicon. Chapter 21 gives a closer look.

### Charging a conductor by induction

Can you charge an object without actually touching it with another charged object? It turns out you can. The process is called *charging by induction*, and it involves the conducting property of metals.

Suppose you charge a plastic rod with cat fur and then bring the rod near a metal ball mounted on an insulating post, as in figure 12.7. The free electrons in the metal ball will be repelled by the negatively charged rod. Free to flow within the ball, they produce a negative charge (excess electrons) on the side opposite the rod and a positive charge (shortage of electrons) on the side near the rod. The overall charge of the metal ball is still zero.

To charge the ball by **induction**, you now touch the ball with your finger on the side opposite the rod, still holding the rod near, but not touching, the ball. The negative charge flows from the ball to your body, because it is still being repelled by the negative charge on the rod. If you now remove your finger and then the rod (in that order), a net positive charge will be left on the ball (fig. 12.8). You can easily test this fact by bringing the metal ball near an electroscope that has been given a negative charge from the plastic rod. The



**Figure 12.7** The negatively charged rod is brought near a metal ball mounted on an insulating post, thus producing a separation of charge on the ball. James Ballard/McGraw-Hill Education



**Figure 12.8** Touching a finger to the opposite side of the metal ball draws off the negative charge, leaving the ball with a net positive charge. James Ballard/McGraw-Hill Education

leaves will come closer together when the ball charged by induction approaches, indicating the presence of positive charge on this ball.

In this experiment, the proper sequence of events is important for the experiment to work. The charged rod must be held in place while the finger touches the ball on the opposite side and is removed. Only after the finger has been removed can the charged rod be moved away. The ball ends up with a charge opposite the charge on the rod. This would also be true if we had used a positively charged glass rod.



Then, the metal ball would end up with a negative charge, because the positive charges would be farthest from the rod and would flow onto your finger.

The process of charging by induction illustrates the mobility of charges on a conducting object, such as the metal ball. The process will not work with a glass ball. Charging by induction is an important process in machines used for generating electrostatic charges, as well as in many other practical devices. It also explains some of the phenomena associated with lightning storms. (See everyday phenomenon box 12.2 later in this chapter.)

### Why are insulators attracted to charged objects?

In our initial experiments with the pith balls, we noted that the pith balls were attracted to the charged rod before they had a chance to become charged themselves (fig. 12.2). How can we explain this phenomenon? What happens inside an insulating object when it is brought near a charged object?

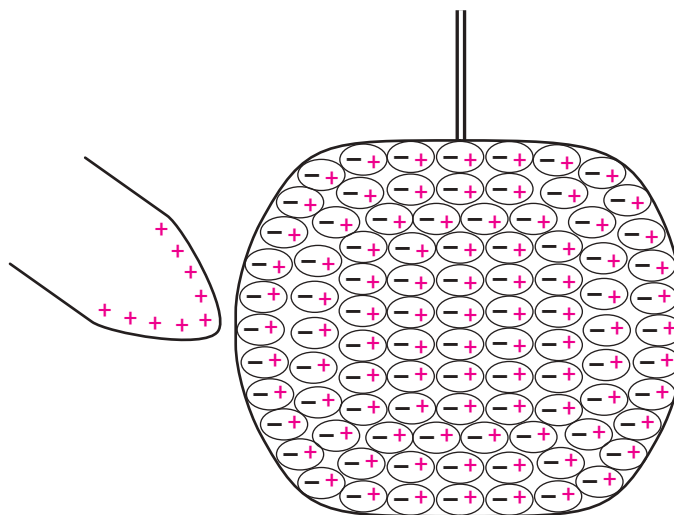
Unlike the charges in the metal ball, the electrons in the pith ball or other insulating material are not free to migrate through the material. Instead, they are tied to the atoms or molecules of the material. Within an atom or molecule, however, charges have some freedom of movement. The distribution of charge within the atom or molecule can change.

Without delving into details of atomic structure, we can develop a rough picture of what happens to the charge in atoms when an insulating material is brought near a charged object. The basic idea is illustrated in figure 12.9, which magnifies the pith ball and greatly exaggerates the size of the atoms. Within each atom, a small distortion of the charge distribution takes place. The negative charge in the atom is attracted to the positively charged rod, and the positive charge is repelled.

Each atom has now become an **electric dipole**, in which the center, or average location, of the negative charge is separated by a slight distance from the center of the positive charge. The atom now has positive and negative *poles*—hence the term *dipole*—and we say that the material has become **polarized**. Overall, these atomic dipoles within the insulating material produce a slight negative charge on the surface of the pith ball near the positively charged rod and a slight positive charge on the opposite surface. The adjacent positive and negative charges within the material cancel one another.

The pith ball itself then becomes an electric dipole in the presence of the charged rod. Because the negatively charged surface is closer to the rod than the positively charged surface, it experiences a stronger electrostatic force, with the result that the pith ball is attracted to the charged rod. At this point, the overall charge on the pith ball is still zero. Once the ball comes in contact with the charged rod, however, some of the charge on the rod can be transferred to the pith ball, which becomes positively charged like the rod. The pith balls are then repelled by the rod, as we observed earlier.

The ability to become polarized is an important property of insulating materials. Polarization explains why small bits



**Figure 12.9** The negative charge in the atoms is attracted to the positively charged glass rod, while the positive charge is repelled. This produces a polarization of the charge in the atoms. The size of the atoms is grossly exaggerated.

of paper or Styrofoam will be attracted to a charged object, such as a synthetic-fabric sweater rubbed against some other material (fig. 12.10). Induced polarization is also a factor in the operation of electrostatic precipitators used to remove particles from smoke in industrial smoke stacks. (See everyday phenomenon box 12.1.)

Experiments in discharging an electroscope show that different materials vary widely in their ability to allow the flow of electric charge. Most metals are good conductors, but glass, plastic, and many other nonmetallic materials are poor conductors and, therefore, good insulators. A few materials, called semiconductors, have intermediate abilities to conduct charge. Conductors can be charged by induction without actually touching the conductor to another charged object. Insulators become polarized in the presence of charged objects, which explains why they are attracted to charged objects.

## 12.3 The Electrostatic Force: Coulomb's Law

Although we cannot see electric charge, we can see the effects of the forces exerted on charged objects. Pith balls and foil leaves refuse to hang straight down when they carry like charges. A repulsive force pushes them apart. Can we describe this force in a quantitative way? How does it vary with distance and quantity of charge? Is it similar in some way to the gravitational force?

## Everyday Phenomenon

## Box 12.1

## Cleaning Up the Smoke

**The Situation.** The effects of static electricity often seem to be just a nuisance. They cause our hair to misbehave and clothing to cling and sometimes produce annoying shocks. Do these effects have any useful applications?

Smoke emissions from burning coal and other industrial processes (as shown in the photograph) have been a problem ever since the industrial revolution began. These emissions usually contain many small particles or soot, which blackened the cities of many industrialized countries beginning in the early 1800s. The problem persists, although we have made great strides in finding ways of removing these small particles from smoke. How is static electricity helpful in addressing this problem?

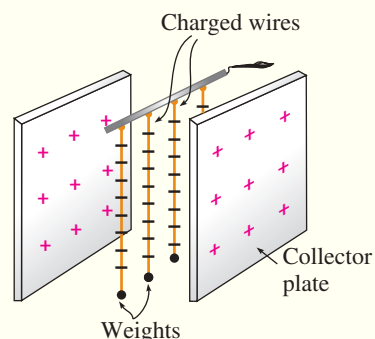


Kodda/123RF

**The Analysis.** Electrostatic precipitators are an important technology for removing small particles from smokestack emissions. The first electrostatic precipitator was patented in 1907 by Frederick Cottrell, who was then a chemistry professor at the University of California in Berkeley. Precipitators have been used ever since, with continuing improvements in design and variety.

The design of early precipitators consisted of a row of highly charged wires (usually negatively charged) spaced between positively charged parallel conducting plates (see diagram). The highly charged wires cause the gas molecules flowing through the apparatus to become ionized by gaining electrons. The ions are attracted by induced polarization of the particles of ash or dust in the exhaust gas and attach to these particles, causing them to become negatively charged. The negatively charged ash particles are then attracted to the positively charged conducting plates and are removed from the stream of gas flowing through the precipitator.

The actual design of modern precipitators is somewhat more complex, but the basic principle remains the same. The conducting plates are often corrugated or have protruding fins to give them a greater surface area. If the conducting plates were not cleaned somehow, they would quickly become coated with ash or dust, so “rappers” must be used to vibrate the plates at regular time intervals. This causes the ash to fall into hoppers, which then must be emptied from time to time.



The particle-laden exhaust gases pass through an array of parallel collecting plates (positively charged), with the negatively charged wires suspended between the plates.

The ionized gas that is produced in the vicinity of the highly charged wires is called a *corona*. The geometry of the wires produces a very strong electric field (see section 12.4) in the immediate area around the wires. The situation is like that pictured in figures 12.14 and 12.15 later in the chapter, in which the field lines become very closely spaced near the charges. It is this very strong electric field in the vicinity of the wires that is responsible for the ionization of the gas molecules and the resulting corona.

Electrostatic precipitators are effective in removing small particles from the smoke produced in metal smelters, cement plants, power plants, and many other industrial applications. Sometimes, they are also used for removing suspended dust from the air in homes and other buildings. They are not, by themselves, effective for removing other pollutants such as sulfur, mercury, or organic molecules from exhaust gases.

For these other purposes, more sophisticated strategies must be used. Many of these applications employ devices called *scrubbers*. A scrubber passes the exhaust gases through a mist of water or other liquid (in a wet scrubber) or through fine particles, in the case of a dry scrubber. Through chemical processes, pollutants such as sulfur are attracted to the injected mist droplets or particles. (Sulfur is of particular concern in coal-burning power plants.) If a dry scrubber is used, an electrostatic precipitator might then be used to remove the particles holding the pollutant.

Depending on how much money we are willing to spend, most pollutants can be removed from exhaust gases by the use of electrostatic precipitators and scrubbers. However, these processes increase the cost of electric power and industrial products and often involve some loss in efficiency. One pollutant that cannot be readily removed is carbon dioxide, because it is a basic combustion product and is in the form of a gas (see chapter 18). Carbon dioxide is a primary greenhouse gas associated with global warming, which is discussed in everyday phenomenon box 10.2. Whenever we burn carbon-based fuels, such as coal, oil, and natural gas, carbon dioxide is released into the atmosphere. The only recourse is to pump it underground or “capture” it in other ways.



**Figure 12.10** Packing “peanuts” made of plastic foam are attracted to a charged rod. *Lars A. Niki*

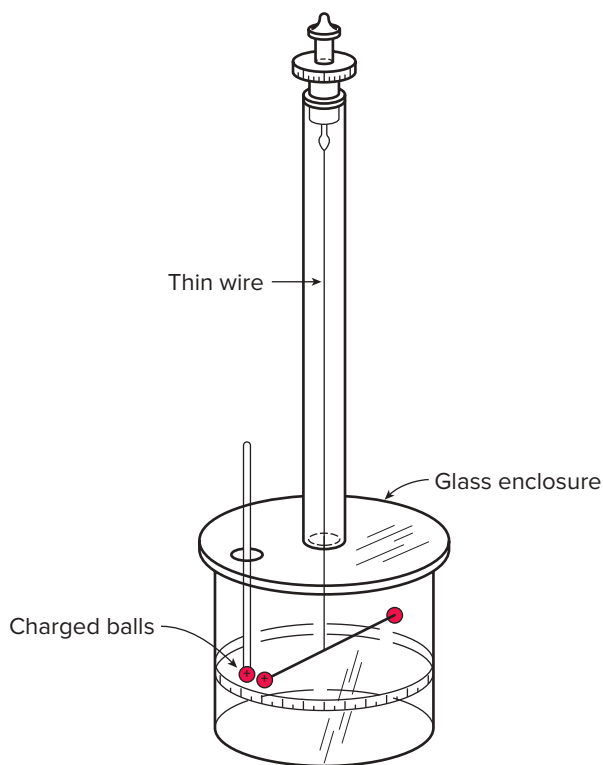
Questions such as these were actively explored by scientists in the latter part of the eighteenth century. Like the gravitational force, the electrostatic force was apparently present even when objects were not in contact—it acted at a distance. Although others had already speculated about the form of the force law, the experiments of French scientist Charles Coulomb (1736–1806) during the 1780s settled the matter, establishing what we now know as Coulomb’s law.

### How did Coulomb measure the electrostatic force?

At first glance, measuring the strength of a force such as the electrostatic force might seem like a simple exercise. In reality, it is not an easy thing to do. Although much stronger than the gravitational force between ordinary-sized objects, the electrostatic force is still relatively weak, so Coulomb needed to develop techniques for measuring small forces. In addition, he was faced with the problem of defining how much charge was present, far from a trivial matter.

Coulomb’s answer to the problem of measuring weak forces was to develop what we now call a *torsion balance*, shown in figure 12.11. Two small metal balls are balanced on an insulating rod suspended at the middle from a thin wire. The balls and wire are contained in a glass-walled enclosure to avoid disturbance from air currents. A force applied to either ball perpendicular to the rod produces a torque that causes the wire to twist. If we have previously determined how much torque is required to produce a given angle of twist, we have a method of measuring weak forces.

To measure the electrostatic force, we must somehow charge one of the balls. A third ball, also charged, can then be inserted on the end of an insulating rod (fig. 12.11). If it has the same type of charge as the ball on the end of the suspended rod, the two charges will repel each other, and the resulting torque will twist the wire. By adjusting the distance



**Figure 12.11** A diagram of Coulomb’s torsion balance. The degree of twist of the wire provides a measure of the repulsive force between the two charges.

between the two charged balls, we can measure the strength of the repulsive force at different distances.

The problem of determining the amount of charge placed on the balls required even more ingenuity. A simple electroscope gave only a rough indication of the quantity of charge present, and no consistent set of units or procedures for specifying quantity of charge was in use at the time of Coulomb’s work. His solution was to develop a system of charge division. He started with an unknown quantity of charge on a single metal ball mounted on an insulating stand, as in figure 12.12. He touched this ball to an identical but uncharged ball mounted on a similar stand. He reasoned that the two balls would now contain equal quantities of charge (half of the original amount on the first ball), which was verified by bringing the balls near an electroscope.

If a third identical metal ball touched one of the first two, the charge would again be divided equally, and these two balls would each have one-half the charge of the ball that did not participate in this second exchange. If several more identical balls are available, splitting the charge can be continued. Although this process does not provide an absolute measure of charge, we can say with confidence that one ball contains twice as much charge, or perhaps four times as much charge, as another.

Coulomb used this process to test the effects of different amounts of charge on the electrostatic force. If the balls used in splitting the charge were identical in size to those in the



**Figure 12.12** By bringing two identical metal balls into contact, one charged and the other one initially uncharged, equal quantities of charge are obtained on the two balls. James Ballard/McGraw-Hill Education

torsion balance, touching one of the torsion-balance balls with one of the others was just one more division of charge. Using these procedures, Coulomb was able to determine how the strength of the electrostatic force varied with the quantity of charge on each object and the distance between the two charged objects.

### What were the results of Coulomb's measurements?

The results of Coulomb's work can be stated in a relationship usually referred to as **Coulomb's law**:

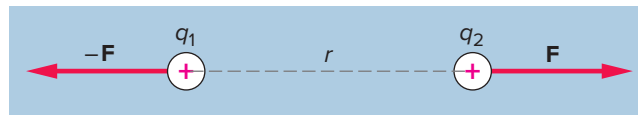
The electrostatic force between two charged objects is proportional to the quantity of each of the charges and inversely proportional to the square of the distance between the charges, or

$$F = \frac{kq_1q_2}{r^2}$$

Here the letter  $q$  represents the quantity of charge,  $k$  is a constant (called *Coulomb's constant*) whose value depends on the units used, and  $r$  is the distance between the centers of the two charges.

Figure 12.13 illustrates Coulomb's law. The forces obey Newton's third law—the two charges experience equal but oppositely directed forces. The two charges shown are both positive, so the force is repulsive, because like charges repel. If one charge were negative and the other positive, the directions of both forces would be reversed.

Although Coulomb himself used different units, we now usually express charge in units called *coulombs* (C). If distance is measured in meters, the value of Coulomb's



**Figure 12.13** Two positive charges exert equal but oppositely directed forces upon one another, according to Coulomb's law and Newton's third law of motion. The force is inversely proportional to the square of the distance  $r$  between the two charges.

### Example Box 12.2

#### Sample Exercise: Calculating Electrostatic Force

Two positive charges, one  $2 \mu\text{C}$  and the other  $7 \mu\text{C}$ , are separated by a distance of 20 cm. What is the magnitude of the electrostatic force that each charge exerts upon the other?

$$q_1 = 2 \mu\text{C} \quad (1 \mu\text{C} = 10^{-6} \text{ C} = 1 \text{ microcoulomb})$$

$$q_2 = 7 \mu\text{C}$$

$$r = 20 \text{ cm} = 0.2 \text{ m}$$

$$F = ?$$

$$\begin{aligned} F &= \frac{kq_1q_2}{r^2} \\ &= \frac{(9.0 \times 10^9 \text{ N} \cdot \text{m}^2/\text{C}^2)(2 \times 10^{-6} \text{ C})(7 \times 10^{-6} \text{ C})}{(0.2 \text{ m})^2} \\ &= \frac{0.126 \text{ N} \cdot \text{m}^2}{0.04 \text{ m}^2} \\ &= 3.15 \text{ N} \end{aligned}$$

constant turns out to be approximately  $k = 9 \times 10^9 \text{ N} \cdot \text{m}^2/\text{C}^2$ . The coulomb itself is determined by measurements involving electric current, discussed in chapter 14. A force computation using Coulomb's law is shown in example box 12.2.

The coulomb (C) is a relatively large unit of charge. At the atomic level, the basic quantity of charge is  $1.6 \times 10^{-19} \text{ C}$ , the magnitude of the charge on an electron (which is negative). A pith ball might ordinarily hold a charge of about  $10^{-10} \text{ C}$ , which represents the absence or presence of a billion or so ( $10^9$ ) electrons. Had the two positive charges in example box 12.2 been coulomb-sized charges instead of microcoulombs, we would have found an enormous force.

### Coulomb's law compared to Newton's law of gravity

The electrostatic force has the same inverse-square dependence on distance as Newton's law of gravitation (see chapter 5). If we double the distance between the two charges, the force between the two charges falls to only one-fourth what it was before the distance was doubled. Tripling the distance produces a force that is one-ninth the force at the

original distance, and so forth. The strength of the interaction between the two charges falls off rapidly when the distance between them is increased.

Because the gravitational force and the electrostatic force are two of the fundamental forces of nature, it is interesting to compare them. How do they differ? Placing their symbolic expressions side by side highlights both the similarities and the differences:

$$F_g = \frac{Gm_1m_2}{r^2} \quad \text{and} \quad F_e = \frac{kq_1q_2}{r^2}$$

An obvious difference is that the gravitational force depends on the product of the masses of the two objects, and the electrostatic force depends on the product of the charges of the two objects. Otherwise, the forms of these two force laws are similar.

A more subtle difference involves the direction. The gravitational force is always attractive. As far as we know, there is no such thing as negative mass. The electrostatic force, on the other hand, can be either attractive or repulsive, depending on the signs of the two charges. The rule that like charges repel and unlike charges attract determines the direction.

Another difference has to do with the strengths of these two forces. For objects of ordinary size, and for subatomic particles, the gravitational force is much weaker than the electrostatic force. At least one of the objects must have an enormous mass (like the Earth) to produce a significant gravitational force. For charged particles at the atomic or subatomic level, the electrostatic force is far more important than the much weaker gravitational force. It is the electrostatic force that holds atoms together and binds one atom to another. Therefore, the electrostatic force is enormously important in the behavior and characteristics of all materials.

Although the basic forms of these two force laws have been known for more than two hundred years, physicists are still trying to understand the underlying reasons for the relative strengths of these and other fundamental forces of nature. The search for a *unified field theory* that would explain the relationships between all of the fundamental forces is a major area of research in modern theoretical physics (see chapter 21). Some of today's students will undoubtedly play important roles in this search.

Charles Coulomb designed a torsion balance to measure the strength of the electrostatic force between two charges. He found that the force is proportional to the size of each charge and inversely proportional to the square of the distance between the two charges. Coulomb's force law has a form very similar to Newton's law of gravitation describing the force between two masses. The gravitational force is always attractive, however, and generally much weaker than the electrostatic force.

## 12.4 The Electric Field

Coulomb's law tells us how to find the force between any two charged objects if the objects are small compared to the distance between them. These forces act at a distance: The charges do not have to be in contact for the force to be exerted. Does the presence of electric charge somehow modify the space surrounding the charge? How can we describe the effects of a large distribution of charges on some other charge?

The concept of **electric field** describes the effect of such a distribution of charges on another individual charge. The usefulness of the idea of a field has made it a central concept in modern theoretical physics. To most of us, the word *field* suggests a field of wheat or a meadow filled with wildflowers. The concept of electric field in physics is somewhat more abstract. An example involving just a few charges can help to introduce the ideas.

### Finding the force exerted by several charges

Using Coulomb's law, we can find the magnitude of the electrostatic force between any two charged objects. If the charged objects are small compared to the distance between them, we often call them *point charges*. If there are more than two point charges, we can compute the net force on any one of them by adding (as vectors) the forces due to each of the other charges.

In the first part of example box 12.3, we find the force on a charge  $q_0$  exerted by two other charges for the situation shown, where the charge  $q_0$  lies between the charges  $q_1$  and  $q_2$ . The resulting forces are added as vectors to obtain the net force on  $q_0$ . The forces due to each of the other charges must be computed separately using Coulomb's law (see example box 12.2 for details of this process).

Notice that the force  $\mathbf{F}_1$  on the charge  $q_0$  exerted by the charge  $q_1$  is considerably larger than the force  $\mathbf{F}_2$  exerted by  $q_2$ , mainly because  $q_2$  is farther from  $q_0$  than  $q_1$  is. The electrostatic force described by Coulomb's law is inversely proportional to the square of the distance between the two charges. The two forces acting on  $q_0$  are in opposite directions, yielding a net force of 9 N in the direction of the larger force.

### What is an electric field?

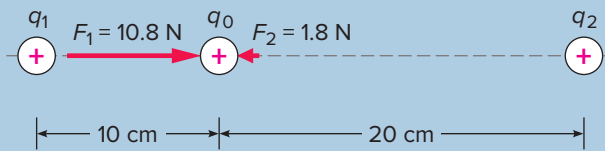
Suppose we wanted to know the force on some other charge placed at the same location as  $q_0$ . Would we have to use Coulomb's law again, find the forces due to each of the other charges, and add them as we did in example box 12.3? There is an easier way that involves the concept of electric field.

Think of the charge  $q_0$  as a test charge that has been inserted at this particular location to assess the strength of the electrostatic effect at that point. By the nature of Coulomb's law, the force on this test charge will be proportional to the magnitude of the charge selected. If we divide the net force by the magnitude of the test charge, we find the force per

## Example Box 12.3

### Sample Exercise: An Electric Field

Two point charges with charges  $q_1 = 3 \mu\text{C}$  and  $q_2 = 2 \mu\text{C}$  are separated by a distance of 30 cm, as shown in the drawing. A third charge  $q_0 = 4 \mu\text{C}$  is placed between the initial two charges 10 cm from  $q_1$ . From Coulomb's law, the force exerted by  $q_1$  on  $q_0$  is 10.8 N, and the force exerted by  $q_2$  on  $q_0$  is 1.8 N.



- What is the net electrostatic force acting on the charge  $q_0$ ?
- What is the electric field (force per unit charge) at the location of the charge  $q_0$  due to the other two charges?

$$\begin{aligned} \text{a. } F_1 &= 10.8 \text{ N to the right} & F_{\text{net}} &= F_1 - F_2 \\ F_2 &= 1.8 \text{ N to the left} & &= 10.8 \text{ N} - 1.8 \text{ N} \\ F_{\text{net}} &= ? & &= 9 \text{ N} \\ & & & \mathbf{F_{\text{net}} = 9 \text{ N to the right}} \end{aligned}$$

$$\begin{aligned} \text{b. } E &= ? & E &= \frac{F_{\text{net}}}{q_0} \\ & & &= \frac{9 \text{ N}}{4 \times 10^{-6} \text{ C}} \\ & & &= 2.25 \times 10^6 \text{ N/C} \end{aligned}$$

$$\mathbf{E = 2.25 \times 10^6 \text{ N/C to the right}}$$

unit charge at this location. (See the second part of the sample exercise in example box 12.3.) Knowing the force per unit charge permits us to compute the force on any other charge placed at that same point.

Using the force per unit charge as a measure of the strength of the electrostatic effect at some point in space lies at the heart of the concept of electric field. In fact, we define *electric field* as follows:

The electric field at a given point in space is the electric force per unit positive charge that would be exerted on a charge if it were placed at that point.

$$\mathbf{E} = \frac{\mathbf{F}_e}{q}$$

It is a vector having the same direction as the force on a positive charge placed at that point. The symbol  $\mathbf{E}$  represents the electric field.

In other words, the ratio  $\mathbf{F}_{\text{net}}/q_0$  that we computed in example box 12.3 is the magnitude of the electric field at that point. We can then use the field to find the force on any other charge placed at that point by multiplying the charge by the electric field:

$$\mathbf{F}_e = q\mathbf{E}$$

If the charge happens to be negative, the minus sign indicates that the direction of the force on a negative charge is opposite to the direction of the field. The direction of the electric field at any point in space is the direction of the force that would be exerted on a *positive* charge placed at that point.

Keep in mind that the electric field and the electrostatic force are not the same. We can talk about the field at a point in space even if there is no charge at that point. The field tells us the magnitude and direction of the force that would be exerted on any charge placed at that point. There must be a charge if there is to be a force, but the field exists regardless of whether there is a charge at that point or not.

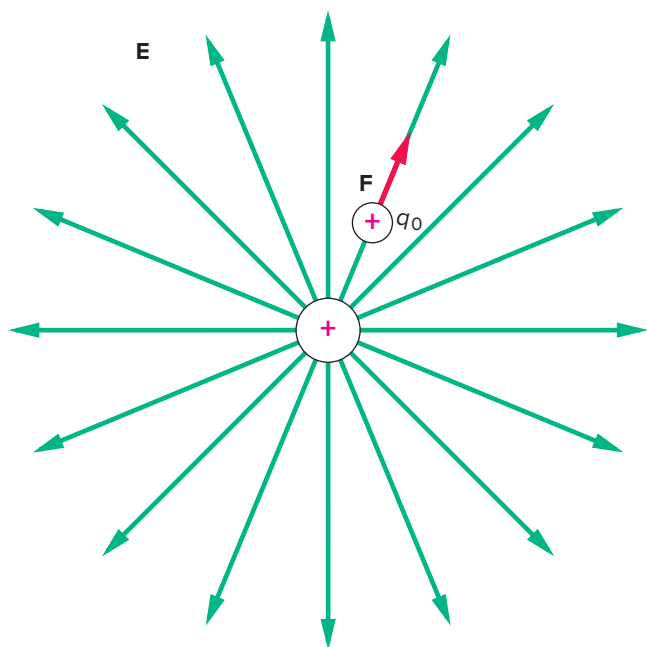
The electric field can exist even in a vacuum. When we use the field concept, we shift our focus from the interactions between particles or objects to the way a charged object affects the space surrounding it. The field concept is not restricted to electrostatics. We can also define a gravitational field or a magnetic field, as well as others.

### How are electric field lines used?

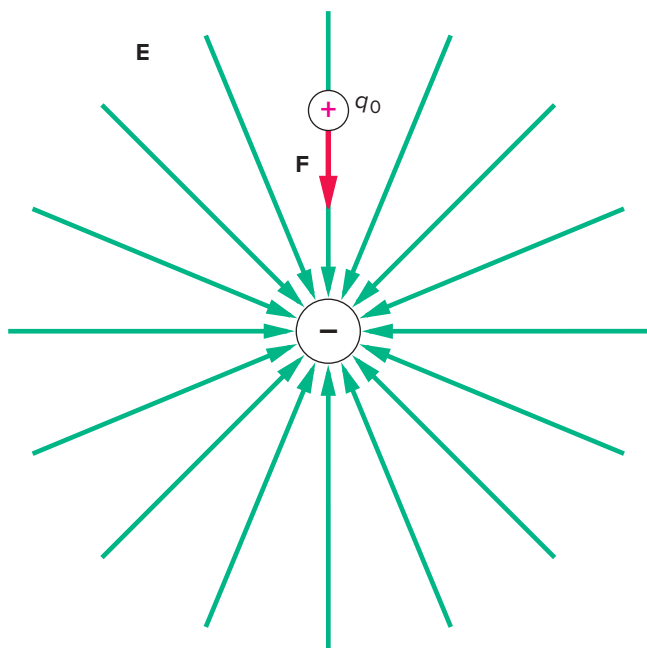
The concept of electric field was formally introduced by Scottish physicist James Clerk Maxwell (1831–1879) around 1865 as part of his highly successful theory of electromagnetism. The idea had already been used informally by Michael Faraday (1791–1867), who developed the concept of what we now call **field lines** as an aid in visualizing electric and magnetic effects. Faraday was not trained in mathematics but was a brilliant experimentalist who made good use of mental pictures.

To illustrate field lines, we can use a positive test charge to assess the field direction and strength at various points around a single positive charge. We will find that the test charge is repelled by the original positive charge wherever we place it around that charge. If we draw lines to indicate the direction of the force on the test charge (which is also the direction of the field), we obtain a drawing like figure 12.14.

Figure 12.14 is only a two-dimensional slice of a three-dimensional phenomenon. The electric field lines associated with a single positive charge radiate in all directions from the charge. If we also adopt the convention that we always start the lines on positive charges and end them on negative charges, the density of the field lines is proportional to the strength of the field. The closer together the field lines are, the stronger the field.

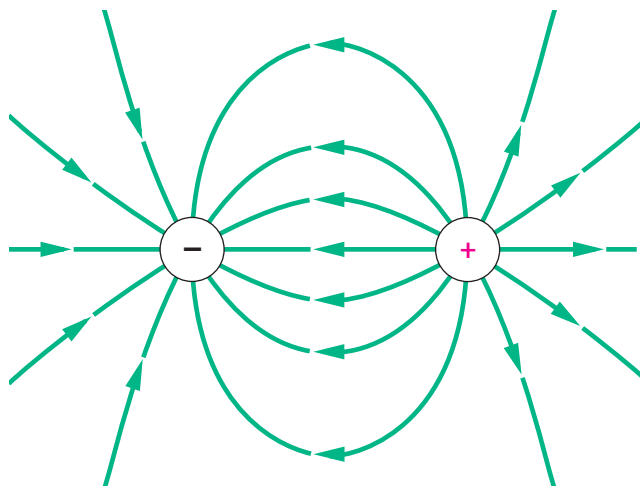


**Figure 12.14** The direction of the electric field lines around a positive charge can be found by imagining a positive test charge  $q_0$  placed at various points around the source charge. The field has the same direction as the force on a positive test charge.



**Figure 12.15** The electric field lines associated with a negative charge are directed inward, as indicated by the force on a positive test charge,  $q_0$ .

Field lines are a means of visualizing both the direction and the strength of the field. Figure 12.15 shows a two-dimensional slice of the electric field lines associated with a



**Figure 12.16** The electric field lines associated with two equal but opposite-sign charges (an electric dipole).

negative charge. Here, the field lines end on the charge and must be directed inward to indicate the proper direction for the force on a positive test charge.

As a final example, consider the field lines associated with the electric dipole in figure 12.16. An electric dipole is two charges of equal magnitude but opposite sign, separated by a small distance. The field lines originate on the positive charge and end on the negative charge. Imagine a positive test charge placed at various points around the dipole. Do the field lines agree with your expectations for the correct direction of the force on the test charge? This is the acid test for any field-line diagram.

Electric field lines are continuous; they never cross one another. The direction of the field lines indicates the direction of the force on a positive test charge placed in the electric field. However, the length of the electric field lines has nothing to do with the size (magnitude) of the electric field. The density of the electric field lines is related to the strength of the electric field. From Coulomb's law, we know the electric field is stronger the closer we are to a charge causing the field. As you can see from figures 12.14, 12.15, and 12.16, the density of the lines is much greater closer to the charge. ▶

The concept of electric field focuses our attention on how the space surrounding an electric charge is affected by that charge. The field is defined as the force per unit charge that would be exerted on a test charge placed at some point in space in the vicinity of the source charges. The direction of the electric field is the same as the direction of the force on a positive test charge placed at that point in space. The field is a useful concept for treating the effects of many point charges on some other charge. Electric field lines can be used to visualize these effects.

## 12.5 Electric Potential

In chapter 6, we defined the potential energy associated with the gravitational force, as well as the potential energy of a spring. Can we define the potential energy of a charged particle being acted upon by an electrostatic force?

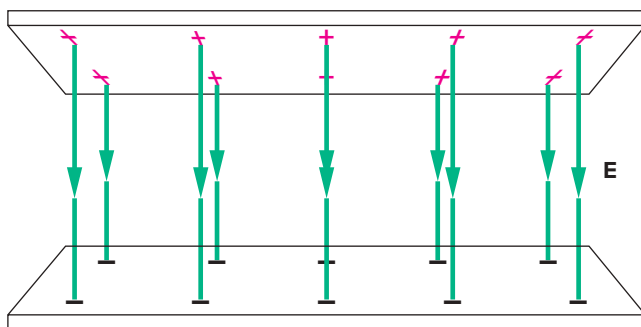
The electrostatic force is a conservative force, which means that we can define an electrostatic potential energy. This potential energy leads to the related concept of *electric potential*, often referred to simply as *voltage*. Voltage is familiar, because we use it to discuss batteries and household circuits. What is voltage, and how is it related to electrostatic potential energy?

### Finding the change in potential energy of a charge

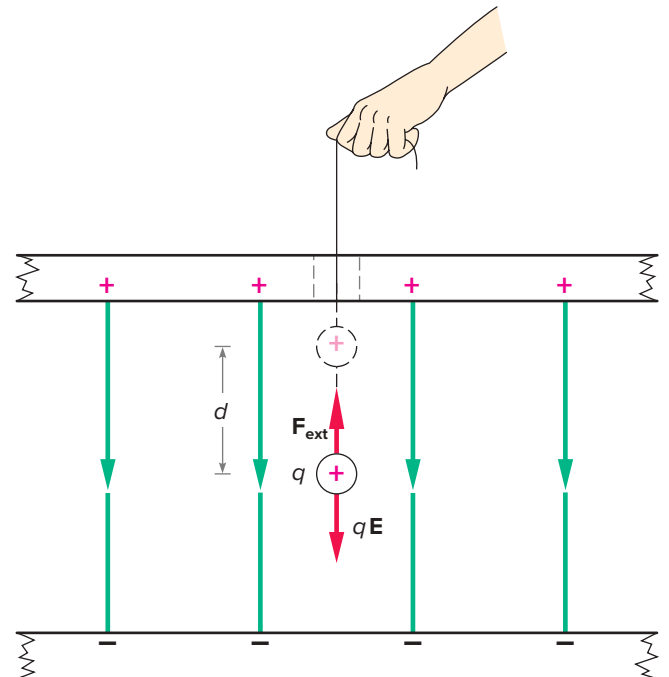
To see how the potential energy of a charge changes with position, the easiest case to consider is a charged particle moving in a uniform electric field. In a uniform field, the electric field lines are parallel and evenly spaced. The field does not vary in direction or strength as we move from point to point within the region where the field exists: It is constant within this region.

How do we go about producing a uniform electric field? Two parallel metal plates with opposite charges, arranged as in figure 12.17, will do the trick. If one plate is positively charged and the other has an equal negative charge, the field lines are straight lines originating at the positive charges and terminating on the negative charges, as shown. You can test this conclusion by thinking about the force on a positive test charge placed between the two plates, as we did in section 12.4.

Two conductors separated by an insulating material, such as air, represent a useful means of storing charge. If the two conductors have charges of opposite sign, these charges are held in place by the attractive electrostatic force between the charges on the opposing plates. We call this arrangement a **capacitor**, which is basically a device to store charge. Capacitors have many applications, particularly in electric circuits.



**Figure 12.17** Two parallel metal plates containing equal but opposite-sign charges produce a uniform electric field in the region between the plates.



**Figure 12.18** An external force  $F_{\text{ext}}$  equal in magnitude to the electrostatic force  $qE$  is used to move the charge  $q$  a distance  $d$  in a uniform field.

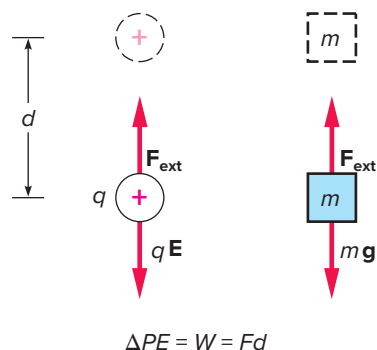
Suppose we now place a positive charge in the uniform-field region between the two plates of the parallel-plate capacitor. This charge will experience an electrostatic force in the direction of the electric field. It will be attracted toward the negative charges on the bottom plate and repelled by the positive charges on the top plate. If we release the charge, it accelerates toward the bottom plate. (*This acceleration has nothing to do with gravity. We can assume that the gravitational force on the charged particle is very small compared to the electrostatic force.*)

If we apply an external force to move the charge in the opposite direction to the electric field, as in figure 12.18, this external force does work on the charge. This work increases the potential energy of the charge (see chapter 6). The process is similar to what happens when we lift an object against the gravitational force or pull on a bowstring doing work against the elastic force. As we discovered in chapter 6, doing work against a conservative force increases the potential energy of the system.

To move the charge without accelerating it, the external force must be equal in magnitude but opposite in direction to the electrostatic force, so that the net force acting on the charge is zero. The electrostatic force acting on the charge is equal in magnitude to the charge times the electric field ( $qE$ ), so the external force must also have this magnitude. The work done by the external force is  $qEd$ , the force times the distance, and this is equal to the increase in potential energy of the charge ( $\Delta PE = qEd$ ).

What we are describing here is similar to using an external force to lift an object against the force of gravity, thus





**Figure 12.19** There is an increase in potential energy when a charge  $q$  is moved against the electrostatic force by an external force. This is analogous to what happens when a mass  $m$  is lifted against the gravitational force.

increasing its gravitational potential energy (fig. 12.19). The gravitational potential energy always increases when we lift an object, but the direction of increase for the electrostatic potential energy depends on the direction of the electric field. If we place the positively charged plate on the bottom, so that the field direction is upward, the potential energy of the positive charge increases when we move the charge downward.

Whenever work is done to move a charged particle against the direction that the electrostatic force would normally tend to move it, we increase its potential energy. If, for example, we move a negatively charged particle away from a positively charged particle, we increase the potential energy of the system. Like stretching a spring, the increase in potential energy can easily be converted to kinetic energy if we release the negative charge and allow it to accelerate toward the positive charge.

### What is electric potential?

How does electric potential, or voltage, relate to potential energy? **Electric potential** is related to electrostatic potential energy in much the same way that the electric field is related to the electrostatic force:  $\mathbf{E} = \frac{\mathbf{F}_e}{q}$ . We can regard the positive charge that is moved in figure 12.18 as a test charge used to determine how the potential energy varies with position. The change in electric potential can be defined like this:

The change in electric potential is equal to the change in electrostatic potential energy per unit of positive charge, or

$$\Delta V = \frac{\Delta PE}{q}$$

The symbol  $V$  represents the electric potential (voltage).

As you can see from this equation, the units of electric potential are those of energy per unit of charge. In the metric system, this unit is called a volt (V), which is defined as 1 joule per coulomb (1 J/C = 1 V). The unit and the term **voltage** suggest the symbol  $V$  commonly used for electric potential.

## Example Box 12.4

### Sample Exercise: Finding the Electric Potential

A uniform electric field of 1000 N/C is established between two oppositely charged metal plates. A particle with a charge of +0.005 C is moved from the bottom (negatively charged) plate to the top plate. (Imagine that a string is tied to the charge and is pulling it upward.) The distance between the plates is 3 cm.

- What is the change in potential energy of the charge?
- What is the change in electric potential from the bottom to the top plate?

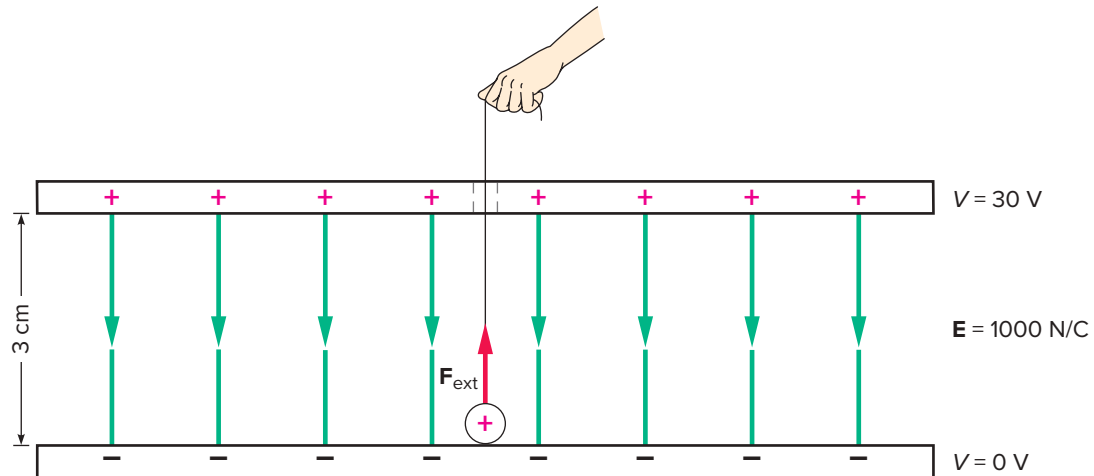
$$\begin{aligned} \text{a. } E &= 1000 \text{ N/C} & \Delta PE &= W = Fd \\ q &= 0.005 \text{ C} & &= qEd \\ d &= 3 \text{ cm} & &= (0.005 \text{ C})(1000 \text{ N/C})(0.03 \text{ m}) \\ \Delta PE &= ? & &= \mathbf{0.15 \text{ J}} \\ \text{b. } \Delta V &= ? & \Delta V &= \frac{\Delta PE}{q} \\ & & &= \frac{0.15 \text{ J}}{0.005 \text{ C}} \\ & & &= \mathbf{30 \text{ V}} \end{aligned}$$

Like the electric field, no charge need be present to talk about the electric potential at some point in space. The change in electric potential as we move from one point to another is equal to change in potential energy *per unit of positive charge* that would occur if a positive charge were moved between these two points. In other words, to find the change in potential energy for any charge, we would multiply the change in electric potential by the size and sign of the charge:  $\Delta PE = q\Delta V$ .

Electric potential and potential energy are closely related, but they are not the same. A positive charge, moving in the direction of increasing electric potential, will have an increase in potential energy. Work would have to be done to move the positive charge against the direction that the electrostatic force would normally tend to move it, thus increasing its potential energy. This also follows from  $\Delta PE = q\Delta V$ , because both  $q$  and  $\Delta V$  are positive in this situation. However, a negative charge, moving in the direction of increasing electric potential, will have a *decrease in potential energy*.

As with gravitational potential energy, it is the *change* in electrostatic potential energy that is meaningful rather than a specific value of potential energy. To state a specific value of either electrostatic potential energy or electric potential, we define a reference point at which the potential is zero. Other values of potential energy are defined from that position. A numerical example involving the computation of electric potential is found in example box 12.4.

Figure 12.20 illustrates the situation in example box 12.4. The potential energy of the charge increases by 0.15 J as the charge is moved from the bottom to the top plate of the parallel-plate capacitor. Because the charge is positive, it can



**Figure 12.20** A positive charge is moved from the bottom plate to the top plate by an external force.

serve as a test charge, so we can compute the change in electric potential, leading to a change in potential of 30 V. If we chose a reference value of 0 V for the bottom plate, the top plate would have a potential of 30 V. Halfway between the two plates, the electric potential would be 15 V. The electric potential increases continuously from 0 V to 30 V from the bottom plate to the top plate.

### How are electric potential and electric field related?

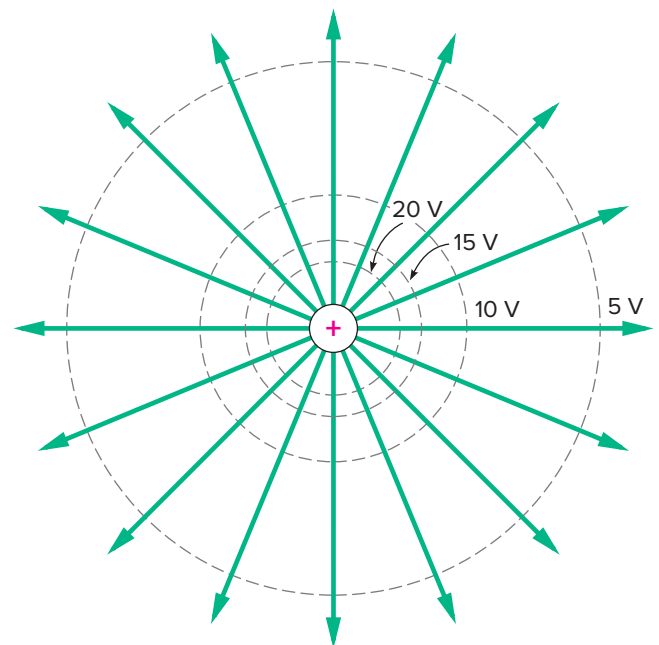
In the case of a uniform electric field, there is a simple relationship between the magnitude of the electric field and the change in electric potential. Because  $\Delta PE = qEd$  for this case, and by definition the difference in electric potential is  $\Delta V = \Delta PE/q$ , dividing  $\Delta PE$  by  $q$  yields

$$\Delta V = Ed$$

In figure 12.20, however, the increase in electric potential occurs in the direction opposite to the direction of the field, because the potential energy of a positive charge increases when we move it against the field.

This simple relationship between  $E$  and  $\Delta V$  is valid only for a uniform field. If the field strength varies with position, the computation is more complex, and different relationships are found. In many practical situations, however, the field is more or less uniform. In fact, because  $E = \Delta V/d$  in this case, we often express the value of the field strength in units of volts per meter (V/m), which is equal to newtons per coulomb (N/C).

The electric potential always increases most rapidly in the direction opposite to the electric field. For the field associated with a positive charge, which is *not* uniform, the electric potential increases as you move toward the charge, and the field lines radiate outward from the charge. Figure 12.21 depicts the electric field for a positive charge with a few values of electric potential indicated at different distances from the charge. The reference level in this case is defined by setting the zero value of electric potential at an infinite distance from the charge.



**Figure 12.21** The electric potential (represented by the dashed lines of constant potential) increases as we move closer to a positive charge.

As shown in figure 12.21, electric potential increases as you move toward a positive charge. If a negative charge is placed near a positive charge, it will be attracted to the positive charge. It will move toward the region of higher electric potential, decreasing its potential energy while gaining kinetic energy. Likewise, a positive charge placed near another positive charge will be repelled and will move toward the region of lower electric potential, also decreasing its potential energy while gaining kinetic energy. ▶

Just as the direction of the electric field is defined as the direction of the force a positive test charge would experience, the electric potential increases in the direction that the potential energy of a positive test charge would increase.

In any situation, we can always determine how the electric potential varies by thinking about what would happen to a positive test charge being moved within the electric field in question. The electric potential always increases as we move toward positive charges and away from negative charges, because the potential energy of a positive charge increases under those conditions. A positive charge moves toward regions of lower electric potential, decreasing its potential energy while gaining kinetic energy, much like a falling rock. A lightning storm (see everyday phenomenon box 12.2) provides several examples of this process.

The potential energy of a positive charge increases when we apply an external force to move the charge in a direction opposite the electric field. The work done is equal to the increase in potential energy. A change in electric potential (also called voltage) is defined as the change in potential energy per unit of charge. The electric potential of a positive charge increases when you move it closer to other positive charges or away from negative charges, because this increases its potential energy. The normal tendency of positive charges is to move to regions of lower electric potential.

**Everyday Phenomenon** Box 12.2

**Lightning**

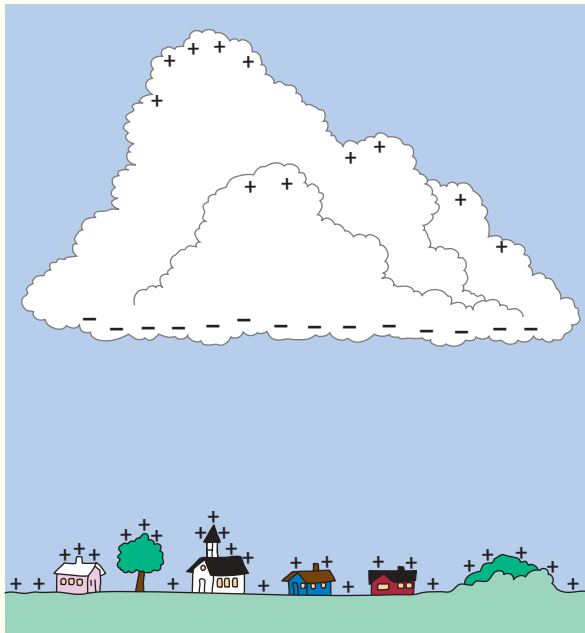
**The Situation.** We have all observed the awe-inspiring beauty and power of an electrical storm. The flashes of lightning, followed at varying time intervals by claps of thunder, can be both fascinating and frightening. What is lightning? How are thunderclouds capable of producing the impressive electrical discharges we see? What happens in an electrical storm?



Flashes of lightning illuminate the area. What is lightning, and how is it produced? *Vasin Leenanuruska/123RF*

**The Analysis.** Most thunderclouds generate a separation of charge within the cloud that produces a net positive charge near the top of the cloud and a net negative charge near the bottom. Highly turbulent convection taking place in the cloud separates and transports the charge: Thunderclouds consist of rapidly rising and falling columns of air and water, with cells of rising air often being found next to cells of falling air and water.

The charge separation within a thundercloud produces strong electric fields inside the cloud, as well as between the cloud and the Earth. Because moist soil is a reasonably good conductor of electricity, a positive charge is induced on the surface



The charge distribution within a thundercloud induces a positive charge on objects on the Earth directly below the cloud.

of the Earth below the cloud due to the negative charge on the bottom of the cloud.

The electric field generated by this charge distribution (pictured in the drawing) can be several thousand volts per meter. Because the base of the cloud usually floats several hundred meters above the Earth's surface, the potential difference between the cloud's base and the Earth can easily be several million volts! (Even during fair weather, there is an electric field of a few hundred volts per meter in the atmosphere near the Earth's surface. This field is weaker, however, and in the opposite direction to what is usually generated between the cloud and the Earth in an electrical storm.)

*(continued)*

What happens when lightning strikes? Dry air is a good insulator, but moist air conducts electricity somewhat more readily. Any material will conduct, however, if the voltage across the material is large enough. The very large voltage between the cloud's base and the Earth creates an initial flow of charge (called the *leader*) along a path that offers the best conducting properties over the shortest distance. This leader heats the air and **ionizes** (removes electrons from) some of the atoms along that path. Because the ionized atoms are charged, they enhance the air's ability to conduct along the path blazed by the leader, and a much greater flow of charge can then proceed.

The following strokes or discharges all take place along this same conducting path in very rapid succession, each one

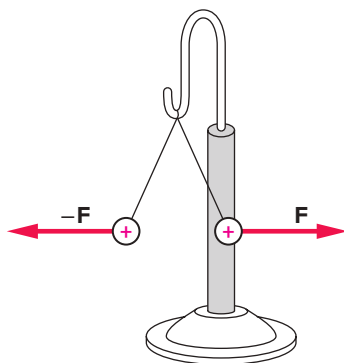
increasing the conductivity along the path. A very large discharge or flow of charge takes place between the Earth and the cloud in a very short period of time. The heating and ionization of the air by the discharge produce the lightning we see. The sound wave that we hear as thunder is produced at the same time, but it takes longer to reach us because sound travels at a much slower speed than light.

A large tree or a person standing on top of a treeless hill provides a favorable path for a lightning discharge. Standing under an isolated tree during a lightning storm is therefore dangerous. Your best bet is to be inside a building or car, but if you are outdoors, find a place that is not near the highest conducting object in your immediate vicinity. Choose a low (and preferably dry) spot and hunker down.

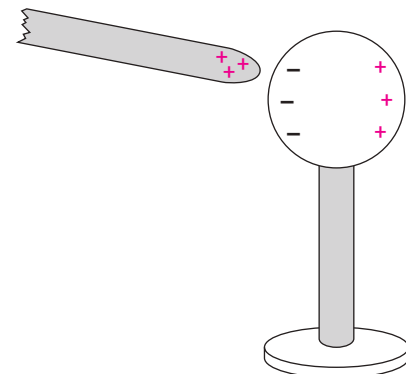
## Summary

Curiosity about simple electrostatic phenomena led us to the description of the electrostatic force and Coulomb's law. The difference between conductors and insulators, and the concepts of electric field and electric potential, is also important in explaining the variety of electrostatic phenomena we observe.

**1 Effects of electric charge.** Rubbing different materials together separates a quantity that we call *electric charge*, which is capable of exerting a force on other charges. There are two types of charge, called *positive* and *negative*, following the single-fluid model introduced by Benjamin Franklin. Like charges repel, and unlike charges attract.



**2 Conductors and insulators.** Different materials vary widely in their ability to permit the flow of charge. These differences between conductors and insulators help to explain why charging by induction works and why uncharged bits of paper (or other insulators) are attracted to charged objects.

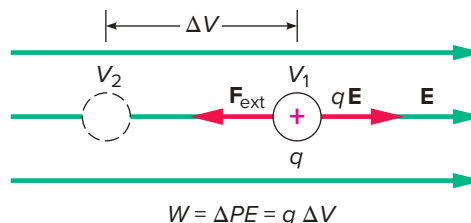
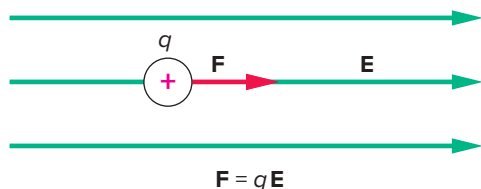


**3 The electrostatic force: Coulomb's law.** Via careful experiments with his torsion balance, Coulomb was able to show that the electrostatic force that two charged objects exert on each other is proportional to the product of the two charges and inversely proportional to the square of the distance  $r$  between the charges.

$$F = \frac{kq_1q_2}{r^2}$$

**4 The electric field.** The electric field is defined as the electric force per unit of positive test charge (newtons/coulomb) that would be exerted if a charge were present at a point in space. Knowledge of the field at some point allows us to compute the

force on any charge placed at that point. Field lines help us to visualize the electric field.



**5 Electric potential.** Electric potential is defined as the potential energy per unit of positive charge that would exist at some point in space if a charge were present there. It is also called voltage, and its units are volts. The change in potential energy of a charge can be found by computing the work done to move the charge against the electrostatic force.

Try the mastery quiz in Connect to increase your conceptual understanding of these electrifying concepts.

## Key Terms

Electric charge, 240

Electrostatic force, 240

Electron, 241

Conductor, 242

Insulator, 242

Semiconductor, 243

Induction, 243

Electric dipole, 244

Polarize, 244

Coulomb's law, 247

Electric field, 248

Field lines, 249

Capacitor, 251

Electric potential, 252

Voltage, 252

Ionize, 255

## Conceptual Questions

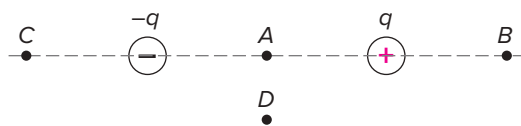
\* = more open-ended questions, requiring lengthier responses, suitable for group discussion

Q = sample responses are available in appendix D

Q = sample responses are available in Connect

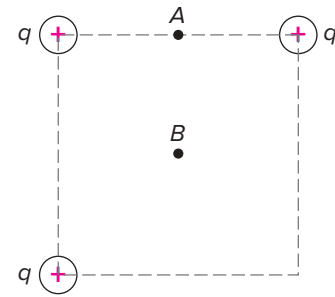
- Q1. When two different materials are rubbed together, do the two materials acquire the same type of charge or different types of charge? Explain how you could justify your answer with a simple experiment.
- Q2. Two pith balls are both charged by contact with a plastic rod that has been rubbed by cat fur.
- What sign will the charges on the pith balls have? Explain.
  - Will the two pith balls attract or repel each other? Explain.
- Q3. When a glass rod is rubbed by a nylon cloth, which of these two objects gains electrons? Explain.
- Q4. Two pith balls are charged by touching one to a glass rod that has been rubbed with a nylon cloth and the other to the cloth itself.
- What sign will the charge on each pith ball have? Explain.
  - Will the two pith balls attract or repel each other? Explain.
- Q5. Do the two metal-foil leaves of an electroscope gain charges of opposite sign when the electroscope is charged? Explain.
- Q6. If you charge an electroscope with a plastic rod that has been rubbed with cat fur, will the metal leaves of the electroscope move farther apart or come closer together when you bring the cat fur near the ball of the electroscope? Explain.
- Q7. When you comb your hair with a plastic comb, what will the sign be on the charge acquired by the comb? Explain. (Hint: Compare this process to rubbing a plastic rod with cat fur.)
- \*Q8. Describe how Benjamin Franklin's single-fluid model can explain what happens when we charge a glass rod by rubbing it with a nylon cloth. How do we get two types of charge from a single fluid? Explain.
- Q9. If you touch the metal ball of a charged electroscope with an uncharged glass rod held in your hand, will the electroscope discharge completely? Explain.
- Q10. If you touch the ball of a charged electroscope with your finger, will it discharge? What does this suggest about the conducting properties of people? Explain.
- Q11. When a metal ball is charged by induction using a negatively charged plastic rod, what is the sign on the charge acquired by the ball? Explain.

- \*Q12. If, when charging by induction, you remove the charged rod from the vicinity of the metal ball before moving your finger from the ball, what will happen? Will the ball end up being charged? Explain.
- Q13. Will bits of paper be attracted to a charged rod even if they have no net charge? Explain.
- \*Q14. Why are pith balls initially attracted to a charged rod and later repelled by the same rod, even though they have not touched any other charged object? Explain.
- Q15. Are electrostatic precipitators (see everyday phenomenon box 12.1) effective for removing pollutants such as sulfur and mercury from exhaust gases? Explain.
- Q16. Can the pollutant carbon dioxide be readily removed from exhaust gases with electrostatic precipitators and scrubbers? Explain. (See everyday phenomenon box 12.1.)
- Q17. Can scrubbers (see everyday phenomenon box 12.1) be effectively used to remove pollutants such as sulfur and mercury from exhaust gases? Explain.
- Q18. Is the concept of torque involved in the operation of Coulomb's torsion balance? Explain.
- Q19. If you had several identical metal balls mounted on insulating stands, explain how you could obtain a quantity of charge on one ball that was four times as large as the quantity on another ball.
- Q20. If the distance between two charged objects is doubled, will the electrostatic force that one object exerts on the other be cut in half? Explain.
- Q21. If two charges are both doubled in magnitude without changing the distance between them, will the force that one charge exerts on the other also be doubled? Explain.
- Q22. Can both the electrostatic force and the gravitational force be either attractive or repulsive? Explain.
- \*Q23. Two charges, of equal magnitude but opposite sign, lie along a line as shown in the diagram. Using arrows, indicate the directions of the electric field at points  $A$ ,  $B$ ,  $C$ , and  $D$  shown on the diagram.



Q23 Diagram

- Q24. Is it possible for an electric field to exist at some point in space at which there is no charge? Explain.
- \*Q25. If we change the negative charge in the diagram for question 23 to a positive charge of the same magnitude, what are the directions of the electric field at points  $A$ ,  $B$ ,  $C$ , and  $D$ ? (Indicate with arrows.)
- \*Q26. Three equal positive charges are located at the corners of a square, as in the diagram. Using arrows, indicate the direction of the electric field at points  $A$  and  $B$  on the diagram.



Q26 Diagram

- Q27. Is the electric field produced by a single positive charge a uniform field? Explain.
- Q28. If we move a positive charge toward a negative charge, does the potential energy of the positive charge increase or decrease? Explain.
- Q29. If we move a negative charge toward a second negative charge, does the potential energy of the first charge increase or decrease? Explain.
- Q30. If a negative charge is moved in the same direction as the electric field lines in some region of space, does the potential energy of the negative charge increase or decrease? Explain.
- Q31. Does the electric potential increase or decrease as we move toward a negative charge? Explain.
- Q32. Is electric potential the same as electric potential energy? Explain.
- \*Q33. In the drawing for question 23, which point,  $B$  or  $C$ , will have the higher electric potential, assuming the potential is zero at infinity? (Hint: Recall that a positive test charge will always move toward a lower potential.) Explain.
- Q34. Will a negatively charged particle, initially at rest in an electric field, tend to move toward a region of lower electric potential if released? Explain.
- Q35. Would you be more likely to be struck by lightning if you stood on a platform made from a good electrical insulator than if you stood on the ground? Explain. (See everyday phenomenon box 12.2.)
- Q36. During a thunderstorm, why can a much greater flow of charge proceed along the path of the leader (after the first initial flow of charge)? Explain. (See everyday phenomenon box 12.2.)
- Q37. If in a typical thundercloud the bottom of the cloud is negatively charged, what is the sign of the excess charge on the ground? Explain. (See everyday phenomenon box 12.2.)
- Q38. Which is better during a thunderstorm: being in your car or standing under a tree on the golf course? Explain.
- Q39. In the chapter opener, it was mentioned that when combing your hair on a dry day, it works better if you wet the comb. Explain why this is so.

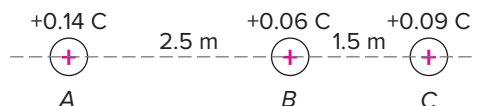
## Exercises

- E1. An electron has a charge of  $-1.6 \times 10^{-19}$  C. How many electrons would be needed to produce a net charge of  $-11.2 \times 10^{-5}$  C?
- E2. Two identical brass balls mounted on wooden posts initially have different amounts of charge: one  $-7 \mu\text{C}$  and the other  $-21 \mu\text{C}$ . The balls are allowed to touch and then are separated again. What is the final charge on each ball?
- E3. Two identical steel balls mounted on wooden posts initially have different amounts of charge: one  $-6 \mu\text{C}$  and the other  $+28 \mu\text{C}$ . The balls are allowed to touch and then are separated again. What is the final charge on each ball?
- E4. Two charged particles exert an electrostatic force of 20 N on each other. What will the magnitude of the electrostatic force be if the distance between the two charges is reduced to one-third of the original distance?
- E5. Two charged particles exert an electrostatic force of 32 N on each other. What will the magnitude of the force be if the distance between the two particles is increased to twice the original distance?
- E6. Two negative charges, each of magnitude  $5 \times 10^{-6}$  C, are located a distance of 12 cm from each other.
- What is the magnitude of the force exerted on each charge?
  - On a drawing, indicate the directions of the forces acting on each charge.
- E7. A charge of  $+3 \times 10^{-6}$  C is located 21 cm from a charge of  $-7 \times 10^{-6}$  C.
- What is the magnitude of the force exerted on each charge?
  - On a drawing, indicate the directions of the forces acting on each charge.
- E8. An electron and a proton have charges of an equal magnitude but opposite sign of  $1.6 \times 10^{-19}$  C. If the electron and proton in a hydrogen atom are separated by a distance of  $5.29 \times 10^{-11}$  m, what are the magnitude and direction of the electrostatic force exerted on the electron by the proton?
- E9. A uniform electric field is directed upward and has a magnitude of 30 N/C. What are the magnitude and direction of the force on a charge of  $-6$  C placed in this field?
- E10. A test charge of  $+12 \times 10^{-6}$  C experiences a downward electrostatic force of 3 N when placed at a certain point in space. What are the magnitude and direction of the electric field at this point?
- E11. A  $+3.4 \times 10^{-6}$  C test charge experiences forces from two other nearby charges: a 3 N force due east and a 15 N force due west. What are the magnitude and direction of the electric field at the location of the test charge?
- E12. A charge of  $-5.8 \times 10^{-6}$  C is placed at a point in space where the electric field is directed toward the right and has a magnitude of  $6.4 \times 10^5$  N/C. What are the magnitude and direction of the electrostatic force on this charge?
- E13. A charge of  $+0.18$  C is moved from a position where the electric potential is 20 V to a position where the electric potential is 50 V. What is the change in potential energy of the charge associated with this change in position?
- E14. Eight coulombs of positive charge flow from the  $+12$  V positive terminal of a battery to the negative terminal at 0 V. What is the change in potential energy of the charge?
- E15. The potential energy of a  $+8 \times 10^{-6}$  C charge decreases from 0.74 J to 0.34 J when it is moved from point A to point B. What is the change in electric potential between these two points?
- E16. The electric potential increases from 52 V to 367 V from the bottom plate to the top plate of a parallel-plate capacitor.
- What is the magnitude of the change in potential energy of a  $-4 \times 10^{-3}$  C charge that is moved from the bottom plate to the top plate?
  - Does the potential energy increase or decrease in this process?

## Synthesis Problems

- SP1. Three positive charges are located along a line, as in the diagram. The 0.14 C charge at point A is 2.5 m to the left of the 0.06 C charge at point B, and the 0.09 C charge at point C is 1.5 m to the right of point B.
- What is the magnitude of the force exerted on the 0.06 C charge by the 0.14 C charge?
  - What is the magnitude of the force exerted on the 0.06 C charge by the 0.09 C charge?
  - What is the net force exerted on the 0.06 C charge by the other two charges?
  - If we regard the 0.06 C charge as a test charge used to probe the strength of the electric field produced by the other two charges, what are the magnitude and direction of the electric field at point B?
  - If the 0.06 C charge at point B is replaced by a  $-0.17$  C charge, what are the magnitude and direction of the

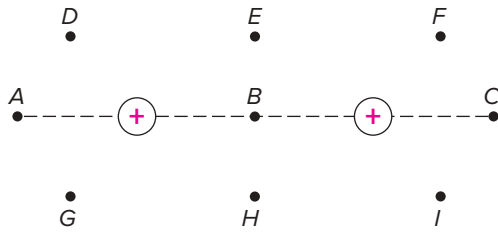
electrostatic force exerted on this new charge? (Use the electric field value to find this force.)



SP1 Diagram

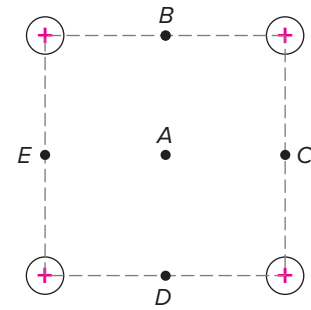
- SP2. Suppose that two equal positive charges lie near each other, as shown in the diagram.
- Using small arrows, indicate the direction of the electric field at the labeled points on the diagram. Think about the direction of the force that would be exerted on a positive charge placed at each of these points.

- b. By drawing an equal number of field lines emerging from each charge, sketch the electric field lines for this distribution of charge. (See the diagrams in section 12.4.)



SP2 Diagram

- SP3. Suppose that one of the two charges in synthesis problem 2 is twice as large as the other one. Use the procedures suggested in parts a and b of synthesis problem 2 for this new situation. (When sketching the field, there should now be twice as many field lines emerging from the larger charge as from the smaller charge.)
- SP4. Suppose that four equal positive charges are located at the corners of a square, as in the diagram.
- Using small arrows, indicate the direction of the electric field at each of the labeled points.
  - Would the magnitude of the electric field be equal to zero at any of the labeled points? Explain.

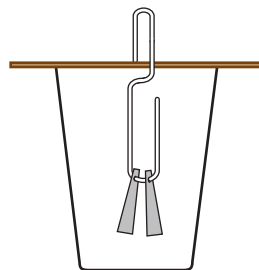


SP4 Diagram

- SP5. Suppose that the top plate of a parallel-plate capacitor has an electric potential of 0 V and the bottom plate has a potential of 500 V. There is a distance of 1.3 cm between the plates.
- What is the change in potential energy of a charge of  $+6 \times 10^{-4}$  C that is moved from the bottom plate to the top plate?
  - What is the direction of the electrostatic force exerted on this charge when it is between the plates?
  - What is the direction of the electric field between the plates?
  - What is the magnitude of the electric field between the plates?

## Home Experiments and Observations

- HE1. The pith ball experiments described in section 12.1 can be done with homemade equipment. Small, lightly wadded pieces of paper or pieces of Styrofoam torn from a coffee cup can be used in place of the pith balls. These can be tied to pieces of thread and hung from any convenient support. Wooden pencils, plastic pens, or glass stirring rods can be used in place of the rods, and many different kinds of fabric are available in the form of clothing.
- Using available materials on a dry day, test to see which combinations of rod and fabric produce the best charge when rubbed.
  - Repeat the experiments described in section 12.1. Can you get both types of charge with materials available?
- HE2. To extend the observations of home experiment 1, a simple electroscope can also be constructed. Use light aluminum foil as the leaves, which can be suspended from a paper clip. One end of the clip can be straightened, poked through a piece of cardboard, and rebent. Place the piece of cardboard on top of a drinking glass or a glass jar (see the drawing), and your electroscope is complete.



HE2 Diagram

- Test your electroscope with some of the materials suggested in home experiment 1.
  - Test the conductivity of different materials, as in section 12.2.
  - Try charging a metal spoon by induction. Wrap the handle of the spoon in a napkin, so that you will not discharge it when you handle it. Test the charge on the spoon with your electroscope.
- HE3. Taking a 4-inch piece of Scotch tape, fold 1/2 inch of tape under one end, so that it can act as a handle. Press the tape onto a tabletop. Treat a second piece of tape identically, but put it elsewhere on the table. Now take both handles and quickly remove the tape strips from the table. Try not to have them curl up and touch your hands—touch them only by the handles.
- Bring them close to one another. What happens?
  - Press the original two tape strips back on the tabletop and label them each with a “B” for bottom. Create two more pieces of tape with handles. Put the two new pieces of tape carefully on top of the two bottom pieces. Rub them gently, so that they adhere well. Label these with a “T” for top. Now remove the set of two tape strips by pulling up on the B tape strips and then separate the B and T tapes. (It is handier if you have a partner, so that you have four hands, one for each tape strip.) Answer the following questions:
    - When you put the two B tape strips close together, what happens?
    - When you put the two T tape strips close together, what happens?
    - When you put a T and a B tape strip together, what happens?
  - From these experiments, can you conclude there are two types of charge? Are like charges attracted to or repelled from one another? What evidence do you have?





hramovnick/Shutterstock

## Electric Circuits

### Chapter Overview

The electrostatic phenomena discussed in chapter 12 involve charges that are not moving. We now turn to moving charges by investigating the concepts of electric circuits and electric current. Together with electric potential (or voltage), introduced in chapter 12, these ideas are central to understanding how simple electrical devices work. As the chapter outline indicates, we begin with circuits and current and then explore how electric current is related to voltage (Ohm's law) and to energy and power. These ideas are then applied to household circuits.

### Chapter Outline

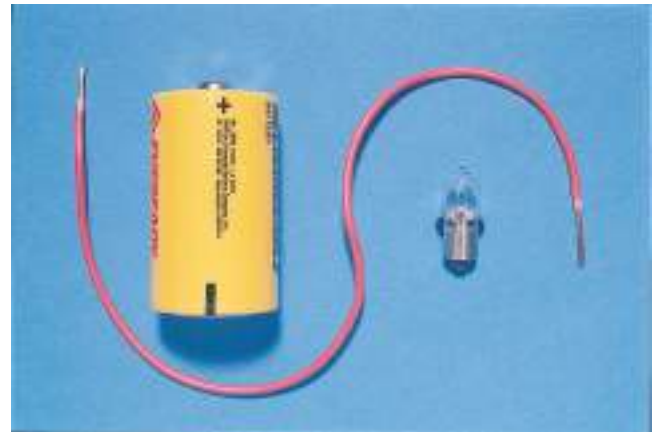
- 1 Electric circuits and electric current.** How is an electric circuit involved in lighting a flashlight bulb? What is electric current? How does it resemble the flow of water in a pipe?
- 2 Ohm's law and resistance.** What is the relationship between current and voltage in a simple circuit? How is electric resistance defined?
- 3 Series and parallel circuits.** How is the flow of electric current affected by series and parallel connections in a circuit? How do we use voltmeters and ammeters?
- 4 Electric energy and power.** How do we apply the concepts of energy and power to electric circuits? What units are used in discussing the use of electrical energy in our homes?
- 5 Alternating current and household circuits.** What is alternating current? How are electric appliances connected to household circuits, and what safety considerations come into play?

**H**ave you ever wondered how a flashlight works? The components are simple and familiar—a lightbulb, a couple of batteries, and a cylindrical case with a switch. The operation of a flashlight is familiar, too. Pushing the switch turns the light on or off. The batteries run down and need to be replaced or recharged. Occasionally, the bulb burns out and must be replaced. But what is happening inside?

You turn electric switches on every day to produce light, heat, or sound, or to run an electric motor. In fact, every time you start your car, you use an electric motor (the starting motor) powered by a battery. You know that electricity is involved in these situations, but *exactly* how things work may be murky.

Suppose you are presented with the components of a flashlight—a bulb, a battery, and a single piece of metal wire (fig. 13.1). Your task is to get the bulb to light. How would you do it? What principles would guide you in producing a working arrangement? If you have these items handy, see if you can get the bulb to light.

This battery-and-bulb exercise presents quite a challenge to many people. Even those who quickly get the bulb to light may not be able to explain the principles involved. This simple example, though, is a good start to a basic understanding



**Figure 13.1** A battery, a wire, and a flashlight bulb. Can you get the bulb to light?

Bob Coyle/McGraw-Hill Education

of electric circuits. From the time your clock radio comes on in the morning to the moment you turn out the last light before going to bed, you are constantly using such circuits.

## Study Hint

If you have the materials handy, you should try the battery-and-bulb experiment before reading further. The delight of figuring out how to get the bulb to light is something not to be spoiled by reading on prematurely. Once you get it to light (without killing the battery), you may wish to experiment with other configurations and try to understand what distinguishes working arrangements from nonworking ones. Experimenting will help to make the concept of a circuit more vivid.

## 13.1 Electric Circuits and Electric Current

A flashlight, an electric toaster, and the starting motor in your car all involve electric circuits, and all use electric current to make them work. The concepts of a circuit and current go hand in hand and are crucial to understanding how electrical devices operate. How can we use the battery-and-bulb exercise mentioned in the chapter introduction to get a handle on these ideas?

### How do we get the bulb to light?

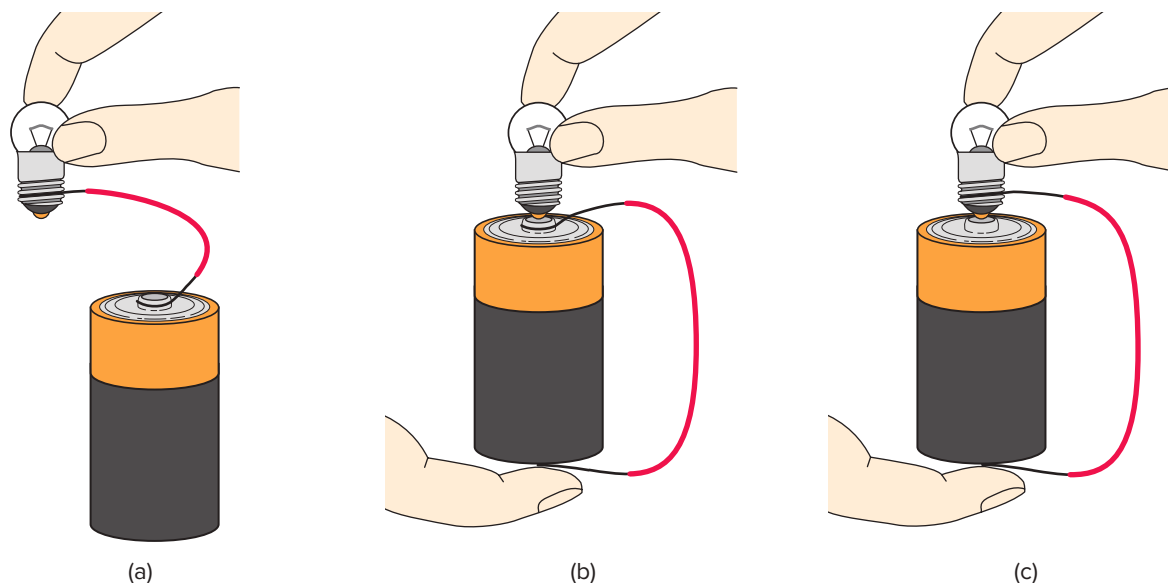
The battery-and-bulb exercise strips the flashlight down to its bare essentials—the bulb, the battery, and a single

conductor. The rest of the flashlight is necessary only to hold it together and provide a more convenient way of switching the light on and off. How do we get the bulb to light with just one wire?

What many people fail to recognize in trying this experiment is that the lightbulb has two distinct connecting places that are electrically insulated from each other. You have to connect to both of them. You also have to complete a path from the lightbulb to both ends of the battery. Such a *closed*, or complete, path is called a **circuit**. The word *circuit* itself implies a closed loop.

Figure 13.2 shows three possible arrangements: the one that works and two that do not. (Which is which?) The circuit shown in figure 13.2a is not complete. Nothing will happen. The bulb will not light, and the wire will not get warm. This case is an incomplete, or *open*, circuit. To be complete, a circuit must have a closed path of conducting elements joining the two ends of the battery. Without a complete path, nothing happens.

Figure 13.2b shows a complete circuit, but it does not pass through the bulb. In this arrangement, the bulb will not light but the wire will get warm and a spark will often be produced when the wire is first connected. The battery will quickly die if the wire is left in place. In figure 13.2c, a wire runs from the bottom of the battery to the side of the lightbulb, and the tip of the bulb rests on the other terminal of the battery. This is the arrangement that works. A complete circuit passes through the bulb and the battery.



**Figure 13.2** Three possible arrangements of the battery, bulb, and wire. Which one lights the bulb, and why does it work?

The circuit in a flashlight is basically the same as the working arrangement in figure 13.2c. The bulb sits on top of a column of two or more batteries in direct contact with the top battery. The side of the bulb is held within a metal sleeve, which is insulated from the rest of the flashlight canister. The switch connects this sleeve to the bottom of the battery, either through the canister itself or through a metal strip that runs to the bottom of the flashlight. Pushing the switch on closes the path. If you have a flashlight handy, take it apart and see if you can determine how this is done.

### What is electric current?

Let's take a closer look at what is happening in the arrangement shown in figure 13.2c. The battery is the energy source for this circuit (as we will discuss in more detail in section 13.4). The battery uses energy from chemical reactions to separate positive and negative charges within the battery. The work done in this process produces an increase in the electrostatic potential energy of the charges, which leads to a voltage difference. Flashlight batteries typically generate a potential difference of 1.5 volts between the terminals.

Because there is an excess of positive charge at one end of the battery and an excess of negative charge at the other, these charges will tend to rejoin by flowing from one terminal to the other if we provide a suitable conducting path. These charges can flow only by an *external* conducting path, however, because of opposing forces associated with the chemical reactions inside the battery. If we simply connect a metal wire to the two terminals, charge will flow through the wire to the opposite terminal.

A flow of electric charge is an **electric current**. To be more precise, current is the *rate* of flow:

Electric current is the rate of flow of electric charge. In symbols,

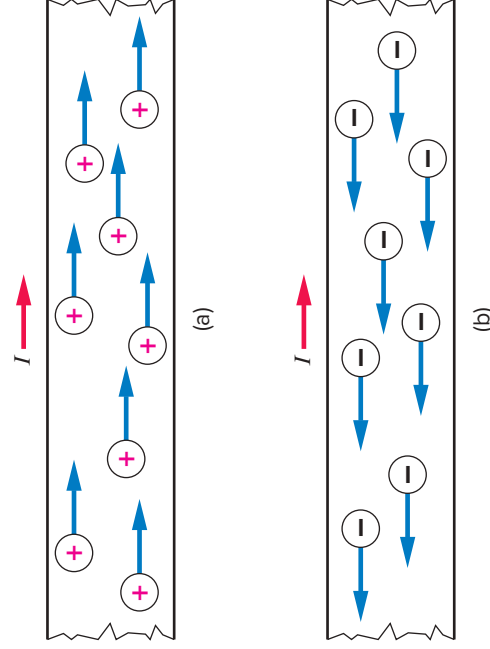
$$I = \frac{q}{t}$$

where  $I$  is the symbol for electric current,  $q$  is the charge, and  $t$  is time. The direction of the current is defined as the direction of flow of positive charge.

The standard unit for electric current is the *ampere*, defined as 1 coulomb per second ( $1 \text{ A} = 1 \text{ C/s}$ ). The coulomb is the unit of charge introduced in chapter 12. The ampere is named after French mathematician and physicist André Marie Ampère (1775–1836), who made many contributions to the theory of electromagnetism. Some of these contributions are discussed in chapter 14. The ampere is often referred to informally as an “amp,” but the correct abbreviation is A.

From the definition and its units of measurement, we see that the size of an electric current depends on how much charge flows in a given time. If 3 C of charge flow through a wire in a time of 2 s, then the electric current  $I$  is  $\frac{3 \text{ C}}{2 \text{ s}} = 1.5 \text{ A}$ .

Figure 13.3 shows two views of charges flowing in a conductor. If the charge carriers were positively charged, their direction of motion, by definition, would be the direction of the conventional electric current (to the right, as in figure 13.3a). In reality, the charge carriers in a metal wire are electrons, which are negatively charged. Because



**Figure 13.3** Positive charges moving to the right have the same effect as negative charges moving to the left. By definition, the electric current is to the right in both cases.

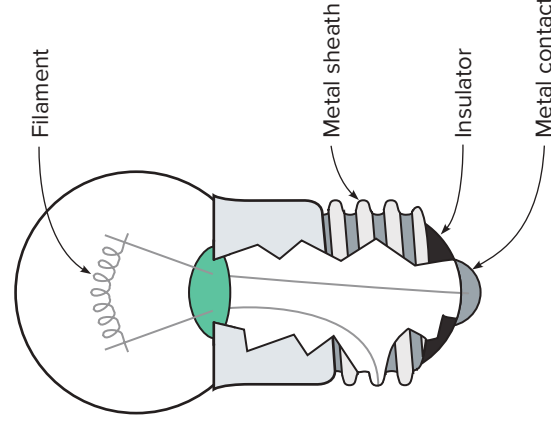
removing negative charges increases the net positive charge, negative charges flowing to the left produce the same effect as positive charges flowing to the right. The direction of the conventional electric current is to the right in figure 13.3b also—in the opposite direction to the motion of the electrons. Charge carriers are sometimes positive, such as positive ions in a chemical solution or the *holes* in a semiconductor (see chapter 21). The electric current is then in the same direction as the motion of the charge carriers.

Nerve cells are sometimes roughly compared to wires in a landline telephone system. The description of the behavior of nerve cells in everyday phenomenon box 13.1 shows it is not that simple.

### What limits the flow of current?

If the battery in our simple circuit is fresh, the chemical reactions will continue to separate charge within the battery, and the current will continue to flow. A metal wire is an excellent conductor, however, so if we directly connect the two terminals of the battery with a wire, creating what is called a *short circuit*, a large current will flow. This will deplete the chemical reactants, and the battery will die after a short time. The wire will also become quite warm as a result of the large current. To avoid this problem, we need to place an element in our circuit (such as the lightbulb) that will provide greater *resistance* to the flow of charge.

If you look closely at an ordinary incandescent lightbulb you will see it consists of a very thin wire filament enclosed inside the glass bulb. This filament is connected to two points inside the bulb: One end is connected to the metal cylinder forming the lower sides of the bulb, and the other is connected to a metal post in the center of the bulb's base (fig. 13.4). These two points are electrically insulated from



**Figure 13.4** A cutaway view of a flashlight bulb. The filament is connected to the metal post at the bottom and to the inside of the metal cylinder.

one another by a ceramic material surrounding the center post. The thin wire filament, although metal and a good conductor, restricts the flow of charge (the current) because of its very small cross-sectional area.

If we force the current to flow through the lightbulb, as in figure 13.2c, a much smaller current will flow than when the wire is connected directly between the terminals of the battery. The bulb's thin wire filament restricts the amount of charge that can flow because the resistance of the filament is much greater than the resistance of the thicker connecting wires. The wire filament is the bottleneck in the circuit, and it gets very hot as we force charges through this constriction. Its high temperature makes it glow, and we have light.

### An analogy to the flow of water

In discussing the battery-and-bulb circuit, we described an electric current as the flow of electric charge. Because charge is invisible, picturing the flow of charge takes a bit of imagination. An analogy can help us visualize what is happening. Water flowing in a pipe is similar to electric current flowing in a circuit.

Figure 13.5a shows a pump that pumps water from a lower tank to a higher tank, increasing the gravitational potential energy of the water (as discussed in chapter 6). The water can remain in the higher tank indefinitely unless we provide a means for it to flow back to the lower tank. If we use a large pipe for this purpose, the water will flow back very quickly. Its rate of flow (the water current) can be measured in units of gallons per second or liters per second. The upper tank will empty quickly unless the pump runs continuously to replace the lost water. If we place a narrow pipe at some point in the path of the returning water,

## Everyday Phenomenon

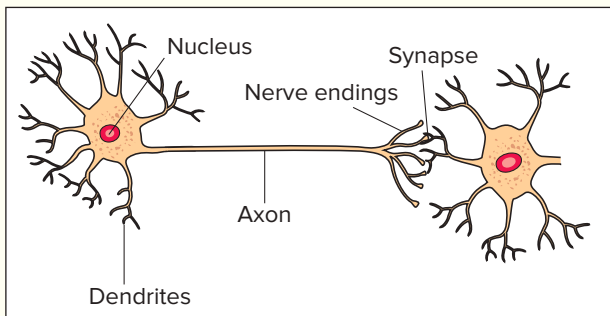
## Box 13.1

### Electrical Impulses in Nerve Cells

**The Situation.** If you make a conscious decision to wiggle your big toe, the big toe will quickly wiggle. Somehow, a signal passes from your brain to the muscles in the toe, causing the muscles to contract. That process happens quickly—there is not much delay between the decision and the toe wiggle.

How does the wiggle command get from your brain to your toe? Does the signal travel over a biological wire or cable of some kind? Is a flow of electric charge involved similar to what happens in the wires of a landline telephone? We know that nerve cells are involved, but how do they work?

**The Analysis.** The study of electrical effects in nerve cells goes back to the work of Galvani and Volta on “animal electricity” that led to the invention of the battery. It was clear even then that an electrical process is involved. However, this process is much more complicated than the simple flow of charge in a wire.

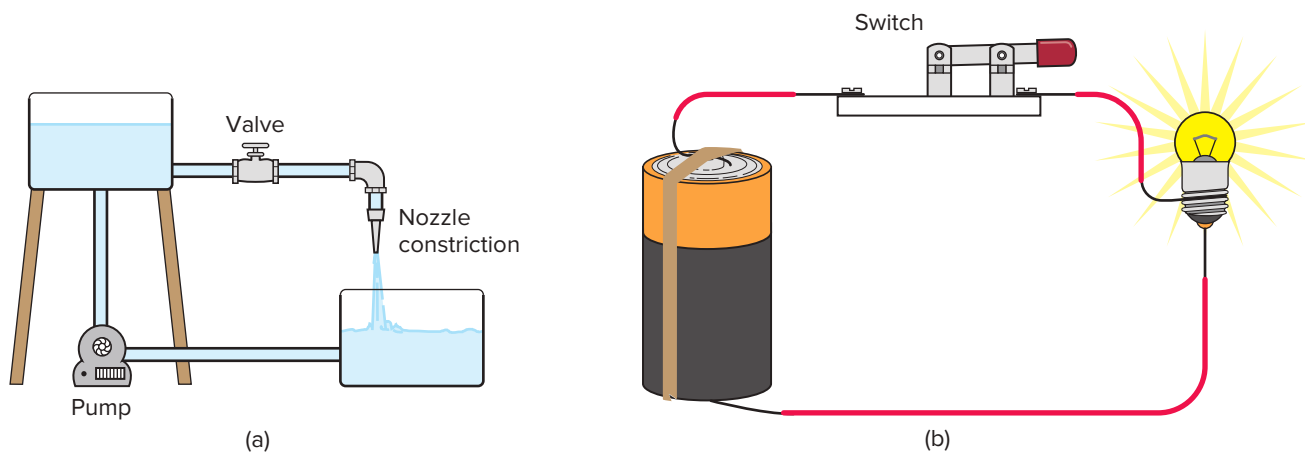


A neuron has a long extension called an axon, which is often much longer relative to the rest of the cell than shown here. The nerve endings may contact dendrites of other cells in synapses.

The signal is transmitted through nerve cells (*or neurons*) like the one pictured in the first drawing. Like any biological cell, the main body of the neuron contains a nucleus and has a number of *dendrites* that can receive signals from other cells. Unlike most other cells, though, neurons have a long, tail-like segment called an *axon* that emerges from the main cell body. The axons can be as long as a meter or more, starting perhaps in the spinal cord and terminating in your foot or hand. At the end of the axon are a number of thinner filaments, or *nerve endings*, that may contact the dendrites of other cells in junctions called *synapses*.

Just as in a phone system, the signal that is transmitted involves a change in voltage. The change in voltage along the axon of a nerve cell is transmitted very differently than that in a metal wire, however. In fact, the primary flow of charge in a nerve cell occurs perpendicularly to the axon rather than along its length. To understand this, we need to take a closer look at the structure of the axon.

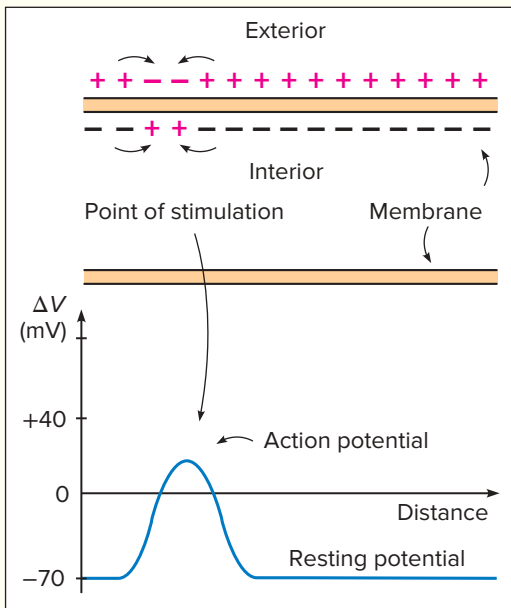
Any cell has a *membrane* that is essentially the outer covering of the cell that holds everything together. The membrane of an axon has some unusual properties. It maintains a balance between certain chemical ions (charged atoms) on the inside and outside surfaces of the membrane. In its normal (resting) state, positively charged sodium ions ( $\text{Na}^+$ ) are excluded from the inside of the cell. There is a small excess of positively charged ions (mostly potassium,  $\text{K}^+$ ) on the outside surface of the membrane and of negatively charged ions (mostly chlorine,  $\text{Cl}^-$ ) on the inside surface. This creates a voltage difference between the inside and outside surfaces of the axon. If we describe this difference as  $\Delta V = V_{\text{inside}} - V_{\text{outside}}$ , it is typically about  $-70 \text{ mV}$ ,



**Figure 13.5** Electric current is analogous to water flow. Which elements correspond in the two systems?

because the inside surface is negatively charged. This voltage difference is called the *resting potential*.

When the axon is stimulated by an electrical signal or other disturbance, the membrane suddenly changes its normal gatekeeping behavior. It briefly allows positively charged sodium ions to rush in through the membrane, thus changing the net charge on the inside from minus to plus near the point of stimulation. The inside of the axon is then positively charged, reversing the sign of the voltage difference across the membrane, as shown in the second drawing, creating a positive voltage spike called the *action potential*.



An influx of sodium ions at the point of stimulation causes the charge to reverse across the membrane of an axon. This creates the action potential that moves along the axon.

The change in the surface charge at the point of the original stimulation causes nearby charges to flow short distances along the surface to counter the change. As indicated in the drawing, positive charges on the outside surface of the membrane are attracted to the net negative charge at the point of stimulation, which leaves a deficit of positive charge at neighboring points on the axon. A similar effect involving negative charges occurs on the inside surface. The charge deficit serves as a stimulus for the neighboring points on the axon, causing sodium ions to rush in at these points. As a result, the action potential (voltage spike) moves down the axon. When the voltage spike reaches the end of the axon, it may be transmitted to another neuron at a synapse or to a muscle cell that causes the toe to wiggle.

Once the voltage spike passes, the axon membrane then works to restore the original balance of ions by pumping the sodium ions back outside of the cell, but this process takes some time. The neuron in its resting state is like a cocked gun waiting to fire, and once it fires it needs to be reset. Exactly how the membrane accomplishes all of this is well beyond the scope of this simple description. It is a biochemical process involving selective diffusion of ions across the membrane. It is a much more involved process than the simple flow of electrons in a wire that causes a voltage signal to propagate in a telephone cable.

How fast does the signal propagate? For longer axons, the speed of propagation can be as high as 150 m/s. For a person of average height, the signal can reach the toes from the brain in a little over a hundredth of a second. This is fast enough for most purposes in a biological organism. It is slow, though, compared to the speed of propagation of electrical signals in a metal wire, which can be as much as half the speed of light, or 150,000,000 m/s. Even in the metal wire, the electrons travel relatively short distances as the voltage signal propagates.

however, this constriction limits the amount of water that will flow. The narrow pipe provides a greater *resistance* to the flow of water.

In figure 13.5b, the battery corresponds to the pump. Both produce an increase in potential energy—of water on one hand and of charge on the other. The thick pipe is like the connecting wires in the circuit, and the nozzle is analogous to the filament in the lightbulb. In fact, the water does become warmer as it flows through the constriction in the pipe, like the warming of the wire filament. A valve placed at some point in the water system corresponds to a switch in an electric circuit. Table 13.1 summarizes the corresponding elements.

Understanding electric current may be easier if you keep in mind its resemblance to a water current. Both can be defined as rates of flow—of water on one hand, of charge on the other. In an electric circuit, there must be a continuous path of conductors (the circuit) for charge to flow. If we break

the circuit at any point, the current stops. The water system also requires a complete loop (unless we are continually supplying water to the upper tank from an external source).

**Table 13.1**

Corresponding Concepts in the Analogy between a Water-Flow System and an Electric Circuit

Water-Flow System	Electric Circuit
Water	Charge
Pump	Battery
Pipes	Wires
Narrow pipe	Wire filament
Valve	Switch
Pressure	Voltage

To get a bulb to light, or for any electric circuit to work, there must be a closed-loop conducting path from one terminal of the power source to the other. This closed path is the circuit, and the rate of flow of charge around that loop is the electric current. The filament in a lightbulb serves as a constriction in the conducting path that limits the flow of current. The filament gets hot as charge flows through it, thus producing light. An analogy to a water-flow system, in which a pump replaces the battery and water takes the place of charge, can help us visualize the concept of current.

## 13.2 Ohm's Law and Resistance

What determines the size of an electric current? In section 13.1, we noted that the large resistance of the wire filament restricted the flow of current. Is this the only effect, or does the voltage of the battery also play a role? Is it possible to predict how much current will flow in a given circuit?

### How does electric current depend on voltage?

In a water-flow system, a high pressure difference between two points in the system will produce a large rate of water flow or current. High pressure can be produced by raising the storage tank to a considerable height above the point of use—this pressure is related to the gravitational potential energy of the water.

Likewise, a large difference in potential energy between the charges at the two ends of a battery is associated with a high voltage and a greater tendency for charge to flow. The size of the electric current is related to the voltage of the battery and to the resistance of the circuit elements. For most components in a circuit, there is a simple relationship between the current, the voltage, and the resistance of the component that can be used to predict the magnitude of the current. This relationship was discovered experimentally by German physicist Georg Ohm (1789–1854) during the 1820s and is known as **Ohm's law**:

The electric current flowing through a given portion of a circuit is equal to the voltage difference across that portion divided by the resistance. In symbols,

$$I = \frac{\Delta V}{R}$$

where  $R$  is the resistance and  $I$  and  $V$  stand for current and voltage, respectively.

In other words, the current is directly proportional to the voltage difference and inversely proportional to the resistance.

Ohm's law is a statement of the experimental fact that resistance is approximately constant for different values of

current and voltage. In section 13.1, we used the term *resistance* in a qualitative sense as a property that restricts the flow of current. A quantitative definition of **resistance** can be obtained by using algebra to rearrange Ohm's law:

$$R = \frac{\Delta V}{I}$$

Resistance,  $R$ , is the voltage difference divided by the resulting current for a given portion of a circuit. The unit of resistance is volts per ampere, which is called an *ohm* (1 ohm = 1 V/A). The ohm is often abbreviated as  $\Omega$ , the Greek letter capital omega.

The resistance of a wire or other circuit element depends on several factors, including the **conductivity** of the material the wire is made of. A wire made of material with high electrical conductivity will have a smaller resistance than one made from a material of lower conductivity. The resistance also depends on the length of the wire and its cross-sectional area. The longer the wire, the greater its resistance—but a thicker wire will have a smaller resistance. (This is why long extension cords are so thick.) Temperature also has an effect. When we heat the filament of a lightbulb, its resistance increases. This is true for any metallic conductor.

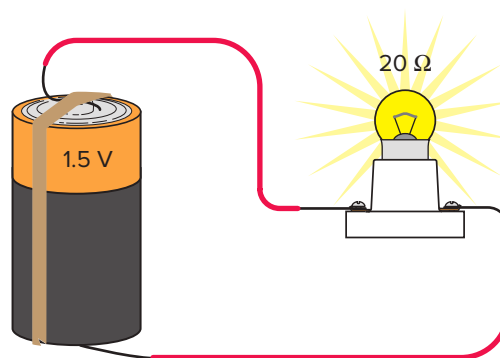
If we know both the resistance of a given portion of a circuit and the applied voltage, the expected current can then be found. Suppose, for example, that a 1.5-volt battery is connected to a lightbulb with a resistance of 20 ohms, as in figure 13.6. If the resistance of the battery itself is negligible, the current can be found by applying Ohm's law,  $I = \Delta V/R$ . Dividing 1.5 volts by the resistance of 20 ohms yields this:

$$I = \frac{1.5 \text{ V}}{20 \Omega} = 0.075 \text{ A}$$

This result could be expressed as 75 milliamperes (mA).

### What is the electromotive force of a battery?

In finding the current through the 20-ohm lightbulb, we ignored the resistance of the battery itself. We also ignored the very small resistances of the connecting wires. If the battery is fresh, its internal resistance is small and can often be neglected. The internal resistance gets larger, however, as the



**Figure 13.6** A simple circuit connecting a 1.5-V battery to a 20  $\Omega$  lightbulb. What is the magnitude of the electric current?

### Example Box 13.1

#### Sample Exercise: Examining a Circuit's Current and Voltage

A 1.5-V battery with an internal resistance of  $5\ \Omega$  is connected to a lightbulb with a resistance of  $20\ \Omega$  in a simple, single-loop circuit.

- What is the current flowing in this circuit?
- What is the voltage difference across the lightbulb?

a.  $\mathcal{E} = 1.5\ \text{V}$       The total resistance of the circuit is

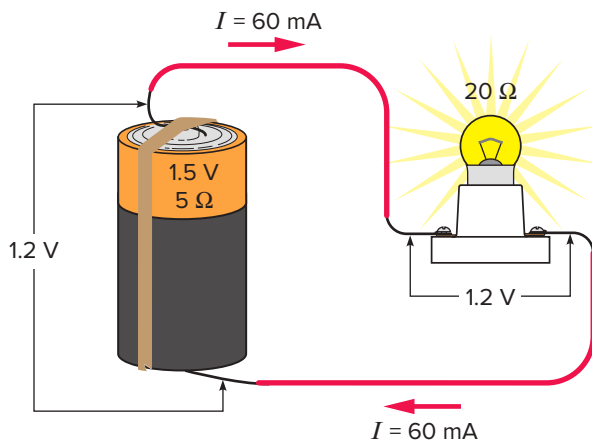
$$\begin{aligned} R_{\text{battery}} &= 5\ \Omega & R &= R_{\text{battery}} + R_{\text{bulb}} \\ R_{\text{bulb}} &= 20\ \Omega & &= 5\ \Omega + 20\ \Omega \\ I &=? & &= 25\ \Omega \end{aligned}$$

$$\begin{aligned} I &= \frac{\mathcal{E}}{R} \\ &= \frac{1.5\ \text{V}}{25\ \Omega} \\ &= \mathbf{0.06\ \text{A} = 60\ \text{mA}} \end{aligned}$$

$$\begin{aligned} \text{b. } \Delta V_{\text{bulb}} &=? & \Delta V &= IR \\ & & &= (0.06\ \text{A})(20\ \Omega) \\ & & &= \mathbf{1.2\ \text{V}} \end{aligned}$$

battery is used and its chemical reactants are depleted. In finding the current, then, the total resistance of the circuit must be considered, including the resistance of the battery. This is done in the sample exercise in example box 13.1, using the values shown in figure 13.7. A smaller current is obtained when the internal resistance of the battery is taken into account.

In example box 13.1, we give the voltage of the battery the symbol  $\mathcal{E}$ , which stands for **electromotive force**. The term itself is misleading, because it is a potential difference (or voltage), *not* a force. The electromotive force is the increase in potential energy per unit charge provided by the



**Figure 13.7** Voltage values for the battery-and-bulb circuit, assuming that the battery has an internal resistance of  $5\ \Omega$ . The current is now 60 mA.

chemical reactions in the battery. Its units are volts (joules/coulomb), and it is usually denoted by  $\mathcal{E}$ . (The concept of electromotive force is discussed in more detail in section 13.4, where we consider the energy aspects of circuits.)

If we measure the voltage difference across either the battery or the lightbulb with a voltmeter while the bulb is operating, we obtain a value of 1.2 V, as in the second part of the sample exercise. If we break the circuit by disconnecting the lightbulb and measure the voltage across the terminals of the battery again, we get a reading of about 1.5 V for the battery. This value of 1.5 V, measured when there is no current flowing through the battery, is the electromotive force of the battery. It is the voltage of the battery when there are no energy losses due to resistive effects within the battery. Therefore, if using a voltmeter to test the output of a battery, it is a good idea to put a “load” on it—that is, connect it in a circuit.

To find the current in example box 13.1, the electromotive force  $\mathcal{E}$  of the battery is divided by the total resistance of the circuit ( $I = \mathcal{E}/R$ ). This equation is similar to Ohm's law, with  $\mathcal{E}$  substituting for  $\Delta V$ , but there is an important difference: Ohm's law can be applied to any portion of a circuit. The voltage difference  $\Delta V$  across that portion is equal to the current times the resistance of that portion ( $\Delta V = IR$ ). The equation involving the electromotive force, on the other hand, is applied to the entire circuit, or loop, and is sometimes referred to as the *loop equation*.

#### What happens when a battery dies?

As a battery gets older, its internal resistance gets larger and larger. The total resistance of the circuit increases and reduces the current flowing through the circuit, as predicted by the loop equation. As the current gets smaller, the bulb becomes dimmer until finally it glows no more. In a dead battery, the internal resistance has become so large that the battery can no longer produce a measurable current.

Surprisingly, if this dead battery is removed from the circuit and tested with a good voltmeter, it will still give a voltage reading of almost 1.5 volts. How can this be? The battery still has an electromotive force, but its internal resistance is so large that it is no longer able to deliver any appreciable current to an external element such as the lightbulb. A good voltmeter does not draw much current, however, so it can still measure approximately the electromotive force of the battery. The condition of a battery is described by its internal resistance rather than by its electromotive force.

Ohm's law says that the electric current through any part of a circuit is proportional to the voltage difference across that segment and inversely proportional to the resistance of that segment. To find the current through a circuit, we divide the electromotive force of the battery by the total resistance of the circuit. This total resistance includes the internal resistance of the battery itself, which gets larger as the battery weakens.



### 13.3 Series and Parallel Circuits

An electric current, like a meandering stream, can split into different streams that rejoin later. Sometimes, there are advantages to arranging a circuit so that this happens, rather than connecting all of the elements in a single loop. How do we describe and analyze these different ways of connecting circuits? Distinguishing between *series* and *parallel* connections is an important step of this process.

#### What is a series circuit?

The simple lightbulb circuit we have been discussing is a single-loop, or *series*, circuit. In a **series circuit**, there are no points in the circuit where the current can branch into side streams or secondary loops. All of the elements line up on a single loop. The current that passes through one element must also pass through the others, because there is nowhere else for it to go. This can be seen in our diagram of this circuit in figure 13.6, but it is frequently easier to see in the diagrams (often called schematics) used to represent circuits.

In figure 13.8, the battery-and-bulb circuit is shown with its schematic alongside. The symbols used to represent various components in the schematic are standard. They will be recognized anywhere in the world where people study or use electric circuits. The lightbulb, for example, is shown as a resistance, for which the standard symbol is a zigzag line:  $\text{⋈}$ . In this case, it appears inside a circle that represents the glass bulb.

The lines in the schematic represent connecting wires, which are usually drawn as straight lines, even though the wires are not likely to be straight in an actual circuit. We generally assume that the resistances of the connecting wires are small enough to be ignored (in comparison to the other resistances in the circuit). The schematic shows the components of the circuit and the connections between them in a way that is both clear and easy to draw.

What happens if we put more lightbulbs in the circuit, *in series* with the others, as shown in both pictorial and schematic forms in figure 13.9? In a series combination of resistances, each resistance contributes to restricting the

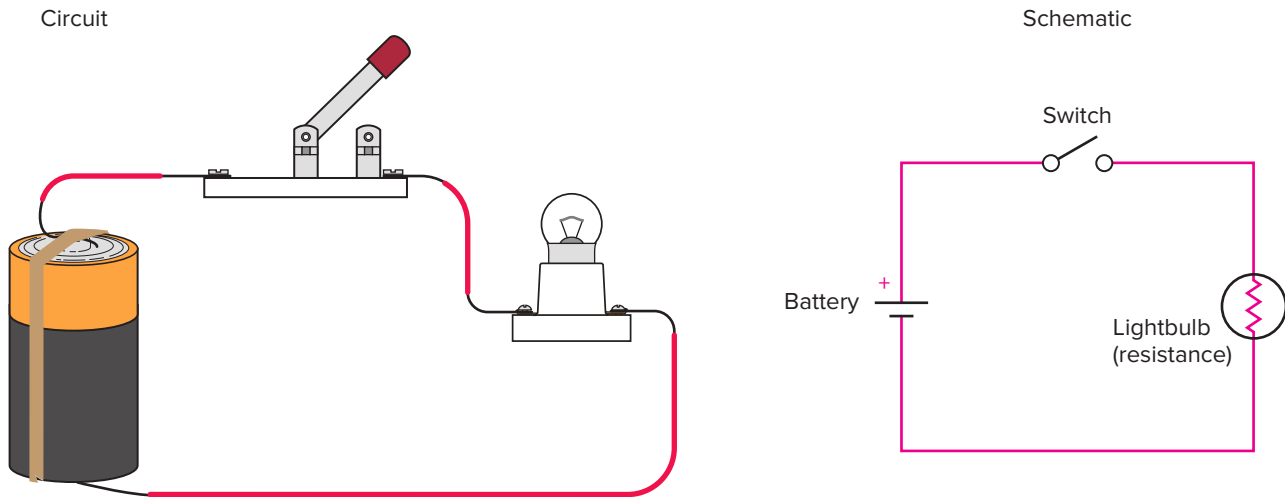


Figure 13.8 The battery-and-bulb circuit with its corresponding schematic.

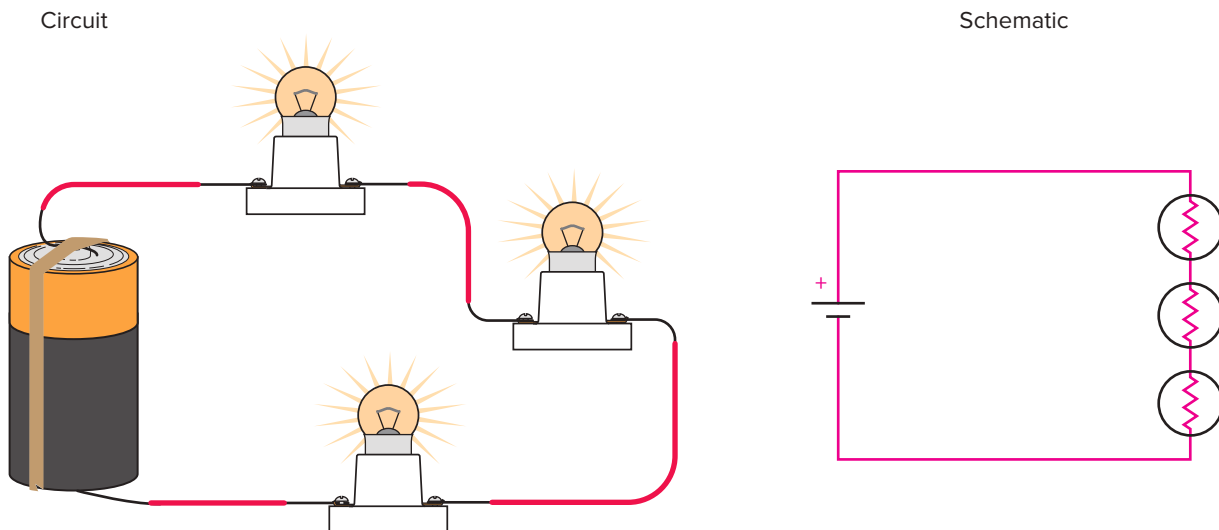


Figure 13.9 A series combination of three lightbulbs and the corresponding schematic.

flow of current around the loop. The total series resistance of the combination,  $R_s$ , is the sum of the individual resistances:

$$R_{\text{series}} = R_1 + R_2 + R_3$$

This is true no matter how many resistances are combined in series. We just add more terms to the sum if there are more resistances.

People often think that the current somehow gets used up in passing through the resistances in a series circuit. This is *not* the case. The same current must pass through each component much like the continuous flow of water in a pipe. *Voltage* is what changes as the current flows through the circuit. Voltage decreases by Ohm's law ( $\Delta V = IR$ ) as the current passes through each resistor. The total voltage difference across the combination is the sum of these individual changes.

If two lightbulbs are connected in series with a battery, the current will be less than with a single bulb, because the total series resistance is larger. The bulbs will glow less brightly in this arrangement. If we wanted brighter light, we would have to add more batteries in series to increase the voltage. This is what is done in many flashlights (though they usually have just one bulb).

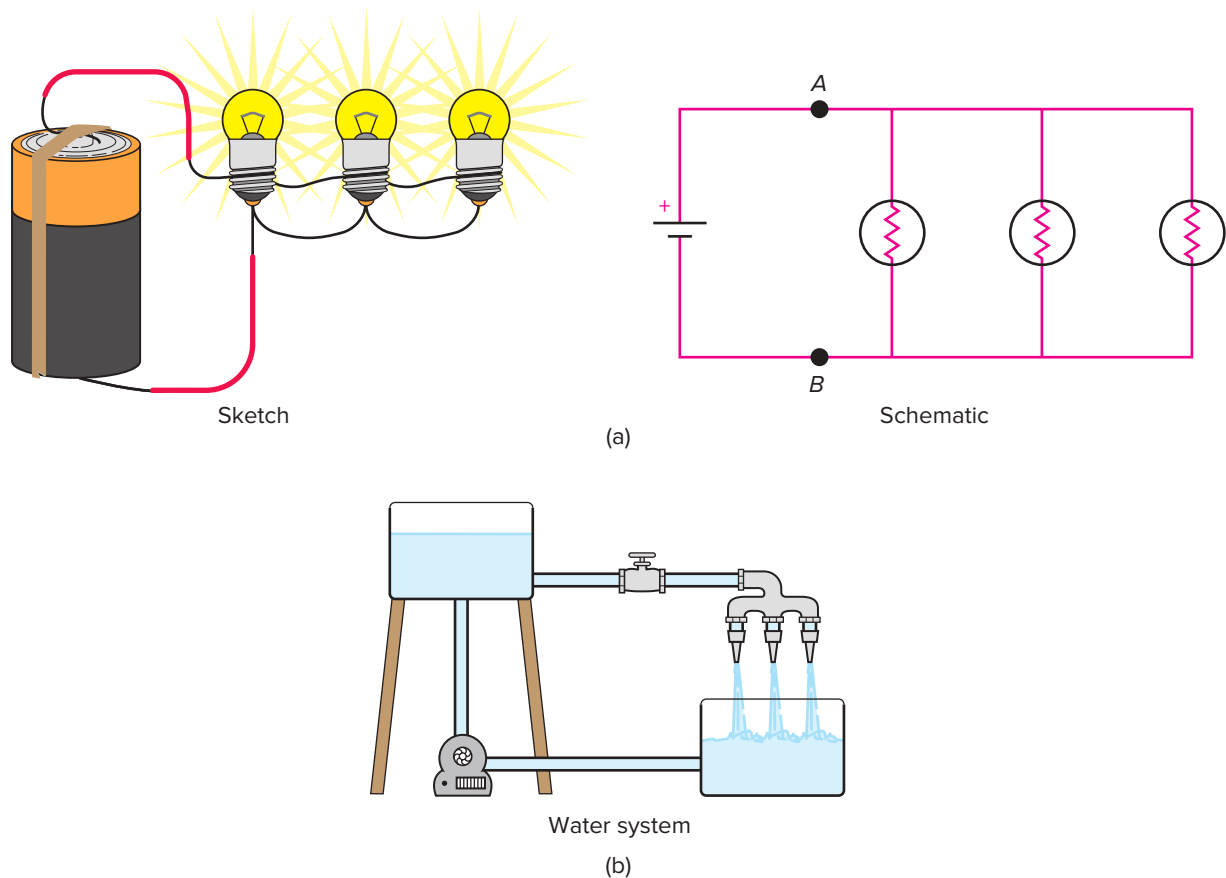
Besides dimmer lights, there is another serious disadvantage to connecting bulbs in series. When a lightbulb burns

out, the filament breaks, which breaks the circuit. When one bulb in a series circuit burns out, the others also go out, because no current can flow around the broken loop. Usually, this is highly undesirable, particularly in a system such as automobile lighting. It also makes it very hard to find the burned-out bulb, as was the case with the old-fashioned strings of Christmas tree lights that were connected in series.

### What is a parallel circuit?

Another way of connecting the bulbs that avoids these problems is shown in figure 13.10. Here, the bulbs are not all in line around the loop. Instead, they are connected in *parallel* with one another. Note that there is now more than one loop in the circuit. In a **parallel circuit**, there are points at which the current can *branch*, or split up, into different paths like the meandering stream mentioned at the beginning of this section. The flow divides and later rejoins.

Does the total effective resistance of the circuit increase or decrease if we add bulbs in parallel with one another? The water-flow analogy may help here. Suppose we add pipes in parallel in a water-flow system (fig. 13.10b). Does this increase or decrease the amount of water (the current) flowing in the system? What does this say about the resistance to the flow of water?



**Figure 13.10** Bulbs connected in parallel, with the schematic and the water-flow analogy also shown. The current now splits into three different paths.

You should conclude that the flow of water is increased when we add pipes in parallel. In effect, we are increasing the total cross-sectional area the water flows through, and therefore *decreasing* the resistance to flow. The same is true in an electric circuit when resistances are connected in parallel. Stated in terms of individual resistances, the effective parallel resistance  $R_p$  is

$$\frac{1}{R_{\text{parallel}}} = \frac{1}{R_1} + \frac{1}{R_2} + \frac{1}{R_3}$$

To find  $R_p$ , we add the reciprocals of the individual resistances and then take the reciprocal of this sum. This always yields a value that is less than any of the individual resistances, as example box 13.2 illustrates.

In a parallel combination of resistances, the voltage difference across each resistance is the same, because they are all connected between the same two points (points *A* and *B* in figure 13.10). The currents, on the other hand, can be different—they add to give the total current through the combination. The current splits up and recombines. A portion of the total current flows through each branch. This leads to a lower total resistance and more current drawn from the battery.

In example box 13.2, the two bulbs have equal resistances—equal currents flow through each. If one bulb had a larger resistance than the other, the current would not divide equally. Instead, a larger portion of the current would flow through the bulb with the smaller resistance, as you might expect. The calculations of equivalent resistance and current would proceed just as shown in example box 13.2.

As example box 13.2 shows, the resistance of the parallel combination is less than the resistance of either bulb by itself. Parallel combinations decrease the resistance and increase the amount of current that will flow. Increased current causes the bulbs to burn more brightly than in a series circuit but also depletes the batteries more quickly. There is no free lunch: We can choose either dim light and a long lifetime or bright light and a short lifetime, depending on how we connect the bulbs to the batteries. The energy available from the batteries is the same in either case.

Another analogy used to understand current is that of the flow of cars on a highway. You can think of the cars as the electrons creating the current, the road as the wires, and the current as the vehicle flow (driving speed times vehicle density). Resistance can be represented as road construction that slows the traffic. If there is a lot of resistance (construction), the current (vehicle flow) decreases. If a circuit has parallel branches (additional lanes), the resistance decreases and the current (vehicle flow) increases. If more circuit elements are put in a series circuit (more road construction sites), the resistance increases and the current (vehicle flow) decreases. This analogy has limitations but may be useful to help visualize some aspects of circuits.

### Example Box 13.2

#### Sample Exercise: Resistance and Current of Lightbulbs in Parallel

Two  $10\ \Omega$  lightbulbs are connected in parallel to each other, and this combination is connected to a 6-V battery, as shown in the schematic.

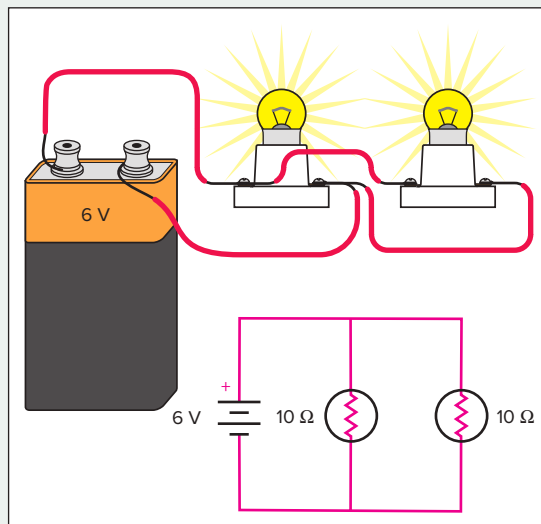
- What is the total current flowing around the loop?
- How much current passes through each lightbulb?

$$\begin{aligned} \text{a. } R_1 = R_2 = 10\ \Omega & & \frac{1}{R_p} &= \frac{1}{R_1} + \frac{1}{R_2} \\ \mathcal{E} = 6\ \text{V} & & &= \frac{1}{10\ \Omega} + \frac{1}{10\ \Omega} \\ I = ? & & &= \frac{2}{10\ \Omega} \\ & & R_p &= \frac{10\ \Omega}{2} = 5\ \Omega \end{aligned}$$

$$\begin{aligned} I &= \frac{\mathcal{E}}{R} \\ &= \frac{6\ \text{V}}{5\ \Omega} \\ &= 1.2\ \text{A} \end{aligned}$$

$$\begin{aligned} \text{b. } I = ? & & I &= \frac{\Delta V}{R} \\ \text{(for either bulb)} & & &= \frac{6\ \text{V}}{10\ \Omega} \\ & & &= 0.6\ \text{A} \end{aligned}$$

A current of 0.6 A flows through each bulb for a total of 1.2 A.



## Use of ammeters and voltmeters

How do we measure currents or voltage differences? You may have used meters, such as a voltmeter or ammeter, to check the electrical systems of your car or for other similar troubleshooting.

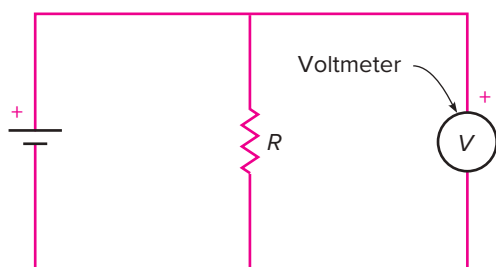
The voltmeter is the easier of the two to use and is more commonly found when working on auto repair and other troubleshooting activities. Suppose we want to measure the voltage difference across a lightbulb in a circuit. Many of the meters available are *multimeters*, which measure voltage, current, and resistance. You choose the appropriate function and range with a switch. Figure 13.11 shows both an *analog* multimeter that uses a needle and scale and a more modern *digital* multimeter that gives a digital readout.

To measure voltage, the leads of the voltmeter are placed *in parallel* with the bulb, as in figure 13.12. A voltage *difference* is the difference in potential energy per unit of charge between two points in a circuit. The voltmeter must, therefore, be connected between these two points, regardless of what other paths for current flow exist. Given the parallel connection, a voltmeter should have a large resistance, so that it does not divert much current from the component whose voltage is being measured.

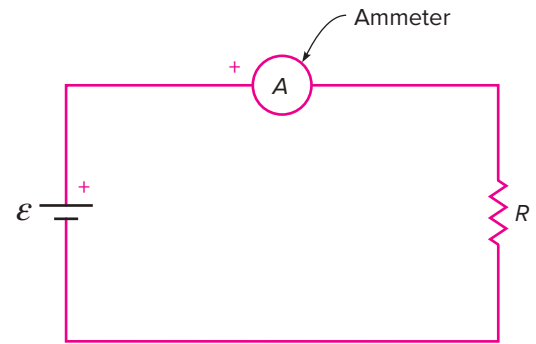


**Figure 13.11** An analog multimeter (with needle and separate scales) and a digital multimeter are commonly used measuring instruments.

Mark Dierker/McGraw-Hill Education



**Figure 13.12** A voltmeter is inserted in parallel with the element whose voltage difference is being measured.



**Figure 13.13** An ammeter is inserted in series into the circuit whose current is being measured.

Would this type of connection work for measuring *current* with an *ammeter*? Think of water flow: To measure water current, which is a rate of flow, you need to insert the gauge directly into the flow. If we were measuring water flow, we would have to cut the pipe and insert a flow gauge between the cut sections, so that the water current being measured flowed directly through the gauge. Likewise, in measuring electric current, we need to break the circuit and insert the meter *in series* with the other components, as in figure 13.13.

Because the ammeter is inserted in series in the circuit and must have some resistance, it will inevitably increase the total resistance of the circuit and decrease the current. An ammeter should have a small resistance, so that its effect on the current is small. Because of this small resistance, using an ammeter calls for more care than using a voltmeter. If you place an ammeter directly across the terminals of a battery, for example, a large current will flow. This can damage the meter and the battery.

With both ammeters and voltmeters, the positive terminal of the meter has to be inserted in the proper direction and connected as in figures 13.12 and 13.13. Tracing from the positive terminal of the battery or power supply, you should come first to the positive terminal of the meter. If you get it backward, the needle of the analog meter will deflect in the wrong direction, which can damage the meter (for digital meters, this is less of a concern). The positive and negative terminals of a meter are usually clearly marked.

The components of a circuit can be connected either in series, in parallel, or in combinations of the two. A series connection has no branches. The current passes through each element in succession, and the resistance of the combination is the sum of the individual resistances. The current in a parallel combination splits into different branches. The effective resistance of the combination is less than any of the individual resistances. Voltmeters are connected in parallel and measure the voltage difference, but ammeters are inserted in series to measure current.

## 13.4 Electric Energy and Power

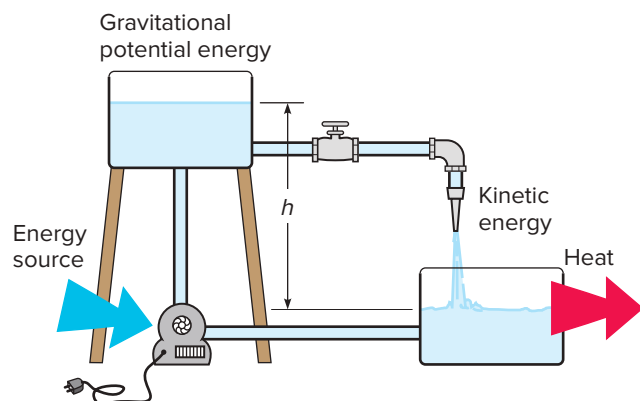
We have talked about batteries as sources of electrical energy in a circuit. We also use the term *power* in discussing our everyday applications of electricity. Energy or power can be used to gain more insight into the behavior of electric circuits, just as we used these ideas in chapter 6 to examine mechanical systems. What happens, for example, to the energy supplied by a battery?

### What energy transformations take place in a circuit?

The analogy between electric circuits and water-flow systems can be used to good advantage here. Energy is supplied to the water-flow system by the pump, which receives its energy from some external source. Electricity, gasoline, and wind are energy sources commonly used for pumping water. The pump increases the gravitational potential energy of the water by lifting it up to a higher tank (fig. 13.14). As the water flows down through pipes to a lower tank or reservoir, gravitational potential energy is transformed into kinetic energy of the moving water.

Once the water comes to rest in the lower tank, the kinetic energy is dissipated by frictional or *viscous* forces within the water or between the water and the inside surfaces of the pipes and tank. Frictional forces generate heat, increasing the internal energy of the water and the surrounding pipes and air. This added internal energy shows up as an increase in the temperature of the water and its surroundings.

An analogy can be made for the electric circuit. The energy is supplied by the battery, which draws its energy from the potential energy stored in its chemical reactants. (Electric energy can also be generated from mechanical energy, as we will see in chapter 14.) The battery, much like the pump, increases the potential energy of electric charges as it moves positive charges toward the positive terminal and negative charges toward the negative terminal. When we complete the circuit by providing an external conducting path from the positive to the negative terminal, charge flows from points



**Figure 13.14** Energy transformations in the water-flow system. What happens to the energy introduced by the pump?

of higher potential energy to points of lower potential energy through the connecting wires and resistances.

As potential energy is lost, kinetic energy is gained by the moving electrons in the electric current. In the end, this kinetic energy is randomized by collisions with other electrons and atoms within the resistors in the circuit. This increases the internal energy of the resistors and connecting wires, which again shows up as an increase in temperature. Kinetic energy has been converted to heat through these collisions.

In both the water-flow system and the electric circuit, the following energy transformations take place:

Energy source  $\rightarrow$  potential energy  $\rightarrow$  kinetic energy  $\rightarrow$  heat

Pipes and resistances get warm as the current flows. In electric circuits, we often use the heat for some specific purpose—to light a lamp, to toast bread, or to warm our homes.

### How is electric power related to current and voltage?

As defined in section 13.2, the potential difference produced by a battery when there is no current being drawn from the battery is often called the *electromotive force* and is represented by the symbol  $\mathcal{E}$ . It is simply the potential energy per unit charge supplied by the energy source, and its units are volts.

Because electromotive force (a voltage) represents a difference in potential energy per unit charge, multiplying electromotive force by charge yields energy. If we multiply by electric current rather than charge, we get energy per unit time, because current is the flow of charge per unit of time. This quantity is the power. Power is the rate of doing work or using energy and has units of energy per unit time. (See section 6.1.) The power supplied by any source of electrical energy is equal to the electromotive force times the current:

$$P = \mathcal{E}I$$

A similar expression can be obtained for the power dissipated when current passes through a resistance. We replace the electromotive force  $\mathcal{E}$  with the voltage difference  $\Delta V$  across the resistance to give  $P = \Delta VI$ . Using Ohm's law, the voltage difference can be expressed as  $\Delta V = IR$ , so power takes this form:

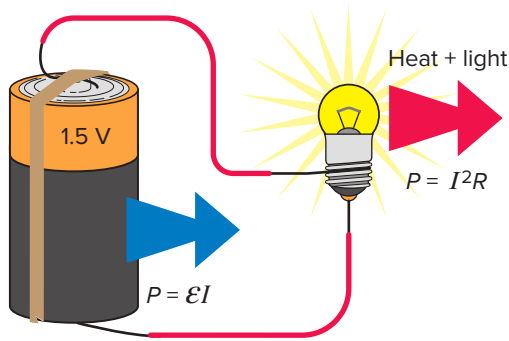
$$P = (IR)(I) = I^2R$$

The power dissipated in the resistance  $R$  is proportional to the square of the current  $I$ .

What is happening to the power in a simple circuit, then? The power delivered by the battery must equal the power dissipated in the resistances in a steady-state situation. In symbols, it is

$$\mathcal{E}I = I^2R$$

As long as the current remains constant, energy is supplied by the battery at a steady rate and is dissipated at the same rate in the resistances. There is no buildup of energy at any point in the circuit. The energy or power input equals the energy or power output (fig. 13.15): Energy is conserved.



**Figure 13.15** The power supplied by the battery in an electric circuit equals the power dissipated in the resistances as heat.

### Example Box 13.3

#### Sample Exercise: Analyzing a Circuit

What is the power dissipated in a  $20\ \Omega$  lightbulb powered by two 1.5-V batteries in series?

$$\begin{aligned}\mathcal{E} &= \mathcal{E}_1 + \mathcal{E}_2 = 3\ \text{V} \\ R &= 20\ \Omega\end{aligned}$$

$$\begin{aligned}\mathcal{E} &= IR \\ I &= \frac{\mathcal{E}}{R} \\ &= \frac{3\ \text{V}}{20\ \Omega} \\ &= 0.15\ \text{A}\end{aligned}$$

$$\begin{aligned}P &= I^2 R \\ &= (0.15\ \text{A})^2(20\ \Omega) \\ &= \mathbf{0.45\ \text{W}}\end{aligned}$$

This can be checked by calculating the power delivered by the batteries:

$$\begin{aligned}P &= \mathcal{E}I \\ &= (3\ \text{V})(0.15\ \text{A}) \\ &= \mathbf{0.45\ \text{W}}\end{aligned}$$

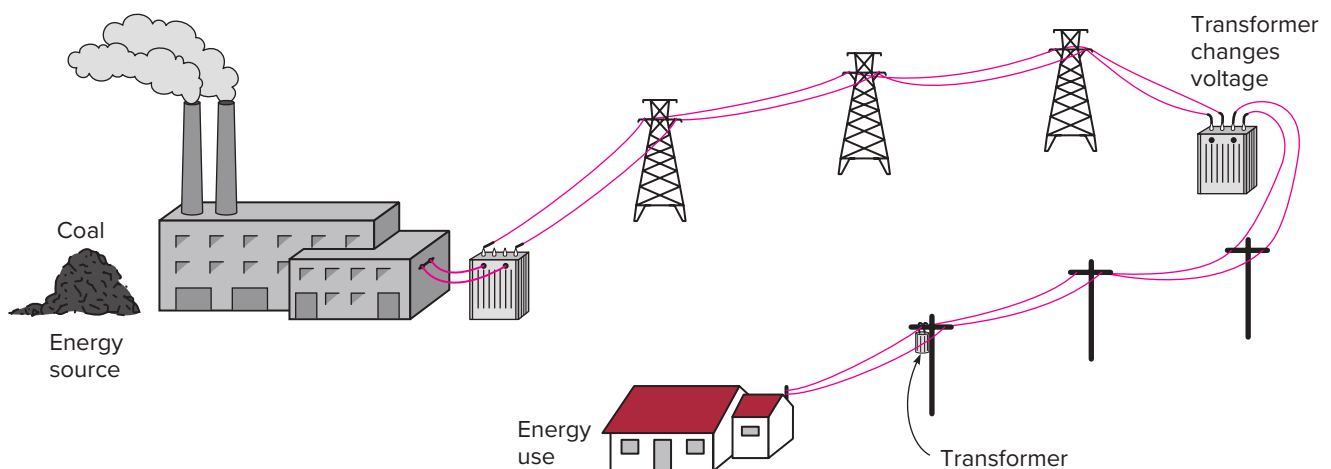
This principle of energy balance is the basis for the loop equation (introduced in section 13.2) used in circuit analysis. Dividing both sides of the energy-balance equation by the current  $I$  yields  $\mathcal{E} = IR$ , the loop equation. Conservation of energy underlies our process of analyzing circuits. Example box 13.3 illustrates these ideas.

#### How do we distribute and use electric power?

Whenever you turn on an electric light or use an electric appliance, you are using electric power. Usually, that power comes not from a battery but from power lines (wires) that deliver power from a distant generating source (fig. 13.16). American inventor Thomas Alva Edison (1847–1931) developed many electrical devices and played a major role in promoting the use of electric power. Edison's invention and refinement of the electric lightbulb provided the original incentive for creating power-distribution systems. The ease with which electric power can be transmitted over considerable distances is one of its main advantages over other forms of energy.

What sources of energy are involved when you use electric power? The source might be the gravitational potential energy of water stored behind a dam. It might also be chemical potential energy stored in fossil fuels, such as coal, oil, or natural gas, or the nuclear potential energy stored in uranium. Like the chemical fuel in a battery, fossil and nuclear fuels can all be depleted, because they are mined from the Earth. (What is the energy source involved in lifting the water stored behind a dam? Can it be depleted?)

In the case of chemical or nuclear fuels, the potential energy stored in the fuel is first converted to heat, then used to run a heat engine, usually a steam turbine (see chapter 11). In the case of hydroelectric power, the water stored behind the dam is run through water turbines to convert potential energy to kinetic energy. Whatever the source of energy, all power plants use electric generators that convert the mechanical kinetic energy produced by the turbines to electric energy. Electric generators are the



**Figure 13.16** Electric power is generated at a central power plant and distributed to users by power lines.

source of the electromotive force for the power-distribution system. (How electric generators work is discussed in chapter 14, when Faraday's law of electromagnetic induction is introduced.)

When you pay your electric bill, you are paying for the amount of electric energy used during the previous month. The unit of energy used for this purpose is the kilowatt-hour, which is obtained by multiplying a unit of power (the kilowatt) by a unit of time (an hour). Because a kilowatt is 1000 watts and an hour is 3600 seconds, 1 kilowatt-hour equals 3.6 million joules. The kilowatt-hour is thus a much larger unit of energy than the joule (introduced in chapter 6). It is a convenient size, however, for the amounts of electrical energy typically used in a home.

How much does it cost to light a 100-watt lightbulb for one day? Electric rates vary across the country, but the average in the United States is about 12 cents per kilowatt-hour. If the light burns for 24 hours, the energy used is found by multiplying the power by the time:

$$(100 \text{ W})(24 \text{ h}) = 2400 \text{ Wh}$$

$$2400 \text{ Wh} = 2.4 \text{ kWh}$$

At 12 cents per kilowatt-hour, the cost is approximately 29 cents. This may seem like a bargain, but as anyone who pays electric bills knows, the cost adds up quickly as the number of appliances multiplies. Many appliances require larger amounts of power than a lightbulb.

The first power-distribution systems were built late in the nineteenth century. The convenience of electric power for running appliances without the noise and exhaust associated with direct use of chemical fuels is the major reason for its wide use. Several places in the world still lack electric power, but it is difficult for most of us to imagine life without it.

The energy transformations that take place in an electric circuit resemble a water-flow system. The power source (pump or battery) increases the potential energy of the water or charges. This potential energy is converted to the kinetic energy of the current, which, in the end, is dissipated as heat. The rate of energy use in a circuit is equal to the electromotive force of the source times the current, which must also equal the rate at which energy is dissipated in the resistances. Various energy sources are used to generate the electric power used in our power-distribution systems.

## 13.5 Alternating Current and Household Circuits

What kinds of circuits are involved in our daily use of electric power? Are they similar to the simple circuits that use batteries and lightbulbs? You probably know that the current

we draw from a wall outlet is *alternating current* (ac) rather than *direct current* (dc). What is the distinction between these kinds of current? Can we use the same ideas employed in discussing simple battery-and-bulb circuits to describe household circuits that use alternating current?

### How does alternating current differ from direct current?

**Direct current** implies that the current flows in a single direction from the positive terminal of a battery or power supply to the negative terminal. This is the normal result when a battery is used. **Alternating current**, on the other hand, continually reverses its direction—it flows first in one direction, then in the other, and then back again. The alternating current used in North America goes through 60 back-and-forth cycles each second, so its frequency is 60 cycles per second, or 60 hertz (Hz).

A *galvanometer* is an ammeter designed so that the needle will deflect in either direction, depending on the direction of the current. If we placed a galvanometer in an alternating-current circuit, the needle would fly back and forth rapidly—assuming that the meter could actually keep up with the changes. Because simple galvanometers cannot respond to such swift changes, the usual result is that the needle vibrates but remains centered on zero. The *average value* of an ordinary alternating current is zero.

An *oscilloscope* is an electronic instrument that plots electric voltage as it varies with time. We can use an oscilloscope to measure a current by displaying the voltage difference across a resistance in the circuit ( $\Delta V = IR$ ). For an alternating current, the resulting graph would look like figure 13.17. On this graph, positive values of current represent one direction of flow, and negative values of current represent the opposite direction. This curve is called a **sinusoidal curve**, because it is described by a trigonometric function, the sine. We met a similar curve earlier in our description of simple harmonic motion in chapter 6.

An alternating current's continually changing direction makes little difference for many electrical applications. In a lightbulb, for example, the heating effect of the charges moving through the filament does not depend on the direction the charges are moving. Many electric appliances make use of this heating effect (lightbulbs, stoves, hair dryers, toasters, electric heaters, and so on). The operation of a toaster is described in everyday phenomenon box 13.2.

Certain applications, such as electric motors, do depend on the kind of current used. We can design motors that operate on direct current, and we can design (more easily) motors that operate on alternating current. A dc motor may not operate on alternating current, though, and an ac motor may not operate on direct current, depending on the design. (See everyday phenomenon box 14.1.)

### What is the effective current or voltage?

Given that the average value of an alternating current is zero, how can we characterize the size of an alternating current? Because the power dissipated in a resistance is

## Everyday Phenomenon

### Box 13.2

#### The Hidden Switch in Your Toaster

**The Situation.** Have you ever thought about why the toast suddenly pops up when you are toasting bread in an electric toaster? Or why an electric coffeemaker turns on and off to keep the coffee warm? Where is the switch in these circuits?

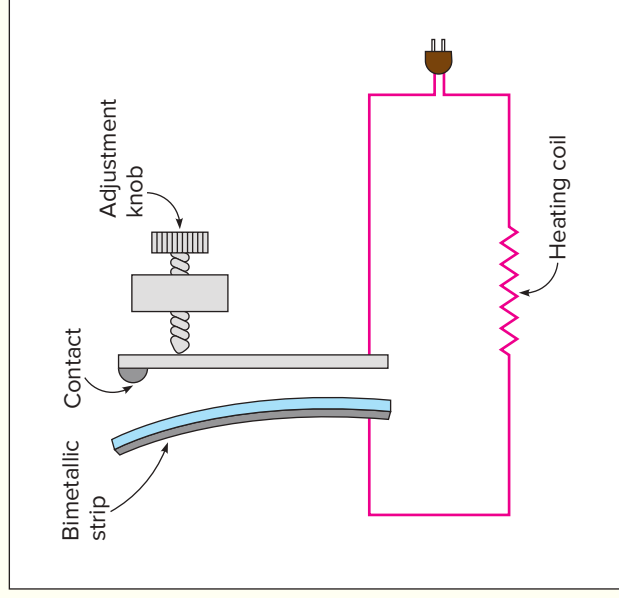
Many appliances with heating elements also use some kind of thermostat. A thermostat is a temperature-sensitive switch that breaks a circuit when the temperature reaches a certain point. How does a simple thermostat work, and where might we find it in the toaster?



Toasters, electric heaters, and coffeemakers are among the appliances that contain thermostats. How do their thermostats work?  
*Bob Coyle/McGraw-Hill Education*

**The Analysis.** If you take apart a toaster or coffeemaker (*making sure it is unplugged first!*) and trace the wires inside the appliance, you will usually find a strip or band of metal that is part of the circuit. This strip is most often located near the entering wires, at a point where it can sense the heat generated by the heating coils of the appliance. Although simple in appearance, this special strip of metal and its connections make up the thermostat.

The special strip of metal is a *bimetallic strip* made up of two kinds of metal bonded together along their length. Because different metals expand at different rates as their temperature increases, the heating of the appliance will cause one side of the bimetallic strip to grow longer than the other side. Because the two metals are bonded together, this differential rate of expansion causes the strip to bend, as in the drawing. The metal with the larger rate of expansion lies on the outside of the curve, and the metal with the smaller rate of expansion lies on the inside, thus compensating for the greater length of the metal with the larger rate of expansion.



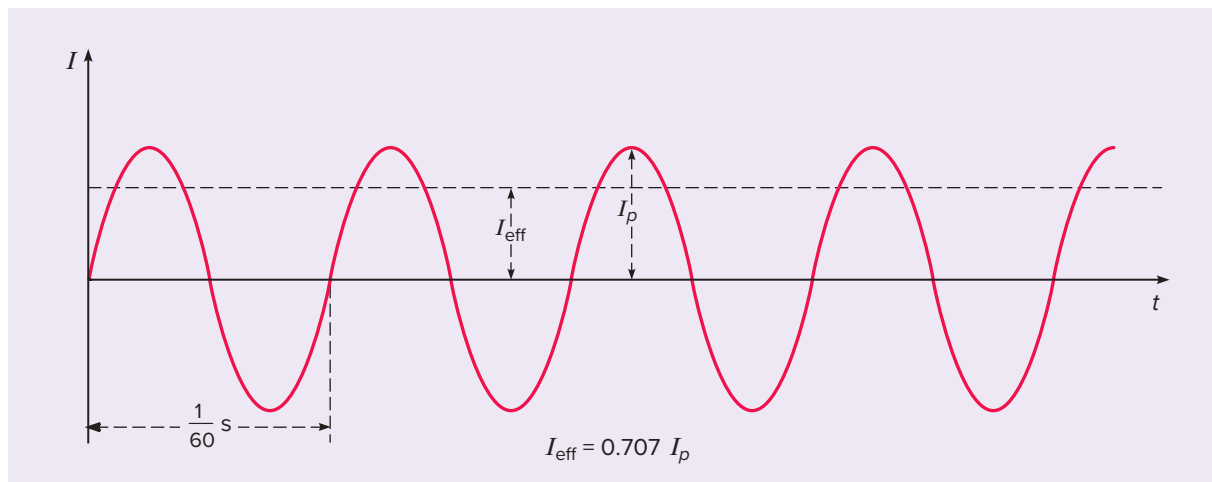
A bimetallic strip bends when heated because the two metals have different rates of thermal expansion. The bending of the strip makes or breaks a circuit.

It is not hard to see how such a device is used as a switch. If we make the strip part of the electric circuit, it can make contact with a metal tab in its unbent state and then pull away and break the circuit as it warms up and bends, as in the drawing. In a toaster, the strip is often part of a mechanical release system. When the toaster handle is pushed down, a ratchet holds it in place against the tension of a spring. The bending of the bimetallic strip releases the ratchet, causing the toast to pop up at the same time that the electric circuit is broken.

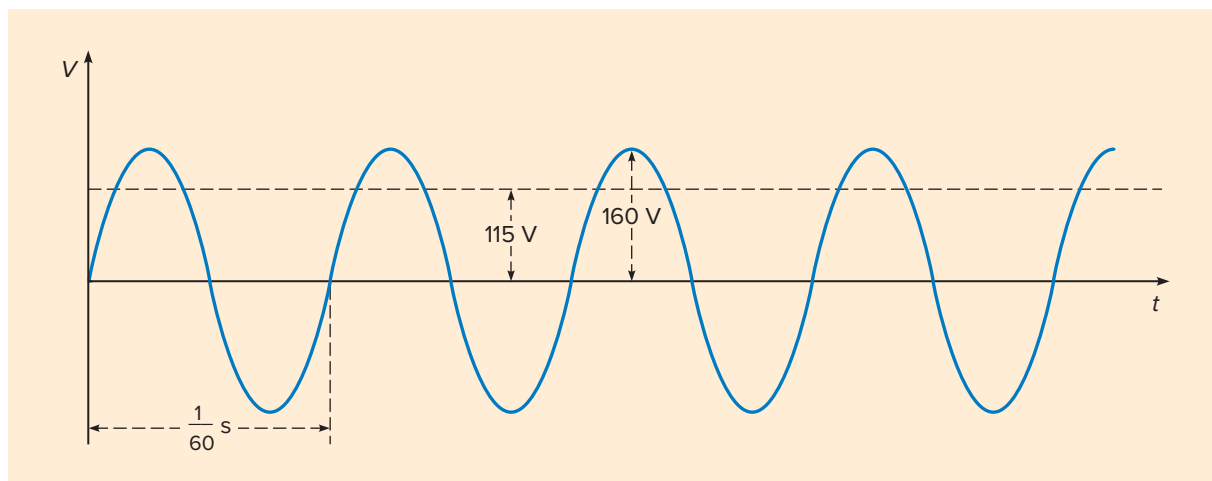
In devices such as room thermostats, where greater sensitivity to small temperature changes is required, the bimetallic strip is usually bent into a coil. This allows for a much longer strip to be used in a small space. It also provides a convenient method for adjusting the set point of the thermostat. A knob or dial allows us to loosen or tighten the coil, resetting the temperature at which changes caused by heating will break the circuit.

This simple physical effect involving different rates of thermal expansion of different metals is used extensively in electric appliances. There are probably applications that have not yet been invented. Perhaps you could dream up a new one and obtain the patent.





**Figure 13.17** Electric current plotted as a function of time for an alternating current. The effective current  $I_{\text{eff}}$  is 0.707 times the peak current  $I_p$ .



**Figure 13.18** Household voltage plotted against time. The peak voltage is about 160 V if the effective voltage is 115 V.

proportional to the square of the current, it makes sense to use an average of the squared current as a measure. (Squaring a negative number yields a positive value.) To find an *effective current*, then, we first square the current, average this value over time, and take the square root of the result.\* For a sinusoidal variation with time, this process yields an effective current approximately seven-tenths (more accurately, 0.707) of the peak value of the current (fig. 13.17).

If the variation of the voltage across an electrical outlet is plotted against time, we get another sinusoidal curve (fig. 13.18). The effective value of this voltage, obtained in the same manner as for the current, is typically between 110 and 120 volts in North America. The standard household power supplied in North America is provided at 115 volts, 60 hertz ac. The standard in Europe is 220 volts, 50 hertz ac, so electric appliances with electric motors (such as electric

shavers and hair dryers) may require adapters to function properly in different places.

We can use these values of effective current and effective voltage to analyze alternating-current circuits and compute values of electric power, as we did for direct-current circuits. (See example box 13.4.)

### How are household circuits wired?

Suppose you plug an appliance into an electrical outlet. Does this create a series circuit or a parallel circuit with other appliances? Does the voltage available depend on what else is connected to the same circuit? These are practical questions with everyday implications.

Household circuits are always wired in parallel to assure that different appliances can be added to or removed from the circuit without affecting the voltage available to each (fig. 13.19). Usually, several outlets are wired as part of the same circuit. Each time you plug in another appliance, you create another loop in the parallel circuit.

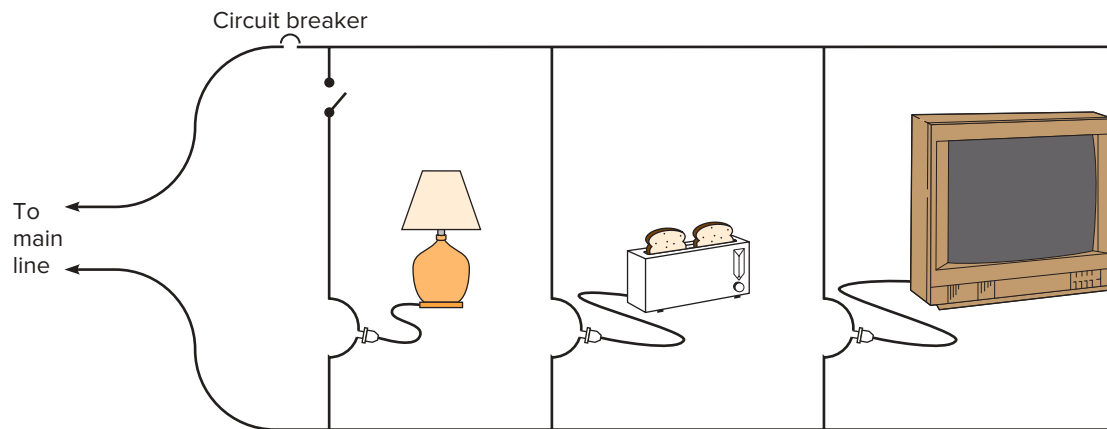
\*The effective current is sometimes called *rms current* for root-mean-square given this method of calculation.

As you add more appliances, the total current drawn from the circuit increases, because the total effective resistance of the circuit decreases when resistances are added in parallel. Too large a current could cause the wires to overheat. To protect against overheating, we add a circuit breaker or fuse before the current branches to the different appliances. If the current gets too large, the fuse will blow or the circuit breaker will trip. The entire circuit is disrupted, and no current will flow to any of the attached appliances.

The current or power rating of an appliance indicates the maximum current normally used by that appliance. A 60-watt lightbulb will draw just half an ampere, as in the sample exercise in example box 13.4. Because a typical household

circuit is fused at 15 to 20 A, several 60-watt bulbs could be turned on without blowing the fuse.

A toaster or a hair dryer, on the other hand, needs much more current than the typical lightbulb. A toaster will often draw as much as 5 to 10 amperes by itself and can cause problems if connected to the same circuit as another appliance with a heating element. You will find current or power ratings printed somewhere on the appliance. Table 13.2 gives some typical values. Except where otherwise indicated, an effective line voltage of 120 V is used to compute the current from the power ratings in this table. Appliances with larger power requirements, like stoves, clothes dryers, and water heaters, are usually connected to a separate 220-V line.



**Figure 13.19** A typical household circuit may have several appliances connected in parallel with one another. A circuit breaker or fuse is placed in the circuit before it branches to the different appliances.

### Example Box 13.4

#### Sample Exercise: Lightbulb Physics

A 60-W lightbulb is designed to operate on 120 V ac.

- What is the effective current drawn by the bulb?
- What is the resistance of the bulb's filament?

$$\begin{aligned} a. \quad P &= 60 \text{ W} \\ \Delta V_{\text{effective}} &= 120 \text{ V} \\ I_{\text{effective}} &= ? \end{aligned}$$

$$\begin{aligned} P &= I\Delta V \\ I &= \frac{P}{\Delta V} \\ &= \frac{60 \text{ W}}{120 \text{ V}} \\ &= \mathbf{0.5 \text{ A}} \end{aligned}$$

$$b. \quad R = ?$$

$$\begin{aligned} \text{From Ohm's law:} \\ \Delta V &= IR \\ R &= \frac{\Delta V_{\text{effective}}}{I_{\text{effective}}} \\ &= \frac{120 \text{ V}}{0.5 \text{ A}} \\ &= \mathbf{240 \Omega} \end{aligned}$$

**Table 13.2**

Power and Current Ratings of Some Common Appliances

Appliance	Power (W)	Current (A)
Water heater	4500 (220 V)	20
Clothes dryer	3000 (220 V)	14
Electric oven	2400 (220 V)	11
Hair dryer	1500	13
Dishwasher	1200	10
Electric iron	1100	9
Coffeemaker	1000	8
Toaster	850	7
Clothes washer	800	7
Blender	400	3
Laptop computer	100	0.8
Ceiling fan	75	0.6
LED TV (37")	60	0.5
Tabletop fan	15	0.1
Clock radio	2	0.02

These values vary, depending on the size and design of a particular appliance.

As you can see from table 13.2, appliances with heating elements require more power than appliances (such as fans or food processors) that use power mainly to run an electric motor. Electronic devices such as televisions and radios require even less power. It is a good idea to check the power or current rating of appliances and be aware of what other appliances are present when you plug a toaster or similar appliance into a new location. If a toaster drawing 7 A and a coffeemaker drawing 8 A are in use on the same circuit as a dishwasher drawing 10 A, you may trip the circuit breaker or blow a fuse.

You do not have to be an electrician to grasp the basics of household circuits. The fuse or breaker box in your house should indicate where each circuit is located in the house and the value of the current limit of the fuse or circuit breaker. Replacing a fuse or resetting a breaker is a routine operation that all of us may need to do. Understanding the

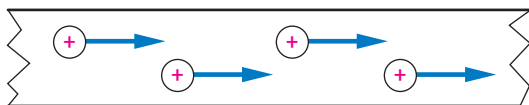
ideas presented in this chapter will help us use household appliances safely.

Direct current flows in a single direction, but alternating current flows back and forth, changing its direction continually. Because the average values of alternating current and voltage are zero, we describe the magnitudes of these quantities by using the effective current or voltage. Household circuits operate on 115 V, 60 Hz ac in North America. When an appliance is plugged into an outlet, it connects in parallel with other appliances on that circuit. A fuse or circuit breaker in one leg of the circuit limits the total current that can flow in that circuit. You should be aware of the current requirements when several appliances are operating on the same circuit, particularly if the appliances have heating elements.

## Summary

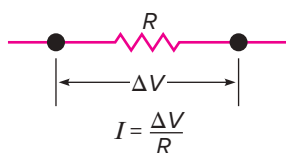
Starting with the simple example of lighting a flashlight bulb, we introduced the concepts of electric circuit, electric current, and electric resistance. Ohm’s law and the relationship between power and current were also used to analyze series and parallel connections and some basic features of household circuits.

**1 Electric circuits and electric current.** An electric circuit is a closed conducting path around which charge can flow. The rate of flow of charge is called *electric current*. It has units of charge per unit of time, or amperes.



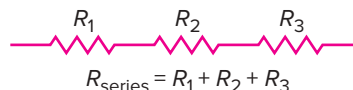
$$I = \frac{q}{t}$$

**2 Ohm’s law and resistance.** Resistance is the property of a circuit element that opposes the flow of current. Ohm’s law states that the current that flows through an element is proportional to the voltage difference across that element and inversely proportional to the resistance.

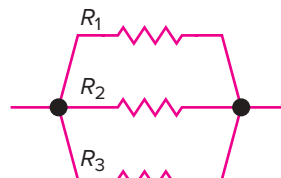


**3 Series and parallel circuits.** When elements are connected in line, so that the current that flows through one must also flow through the others, the elements are connected in *series*. When the current can branch into different paths, the elements are

connected in *parallel*. The equivalent resistance of a parallel combination is less than that of any of its components.

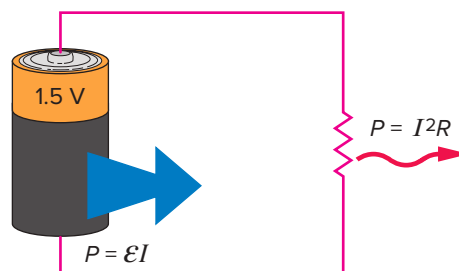


$$R_{\text{series}} = R_1 + R_2 + R_3$$



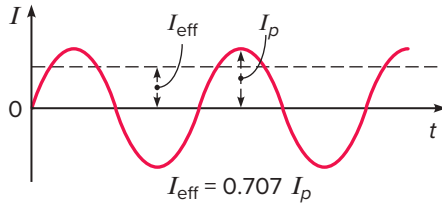
$$\frac{1}{R_{\text{parallel}}} = \frac{1}{R_1} + \frac{1}{R_2} + \frac{1}{R_3}$$

**4 Electric energy and power.** Because voltage is potential energy per unit charge, multiplying a voltage difference by charge yields energy. Being that current is the rate of flow of charge, multiplying a voltage difference by current yields power, the rate of energy use. The power supplied by a source must equal the power dissipated in the resistances.



$$P = \epsilon I = I^2 R$$

**5 Alternating current and household circuits.** Household circuits use alternating current, which is continually reversing its direction, unlike direct current, which flows in one direction only. When we plug in appliances, we connect them in parallel with other appliances on the same circuit. The fuse or circuit breaker used to limit the current is in series with one leg of the circuit.



Electric circuits are a ubiquitous part of modern culture, yet most people do not have a fundamental understanding of how they work. The mastery quiz on Connect will help you develop a basis for understanding the circuitous ideas introduced here. Try it.

## Key Terms

Circuit, 261  
 Electric current, 262  
 Ohm's law, 266  
 Resistance, 266

Conductivity, 266  
 Electromotive force, 267  
 Series circuit, 268  
 Parallel circuit, 269

Direct current, 274  
 Alternating current, 274  
 Sinusoidal curve, 274

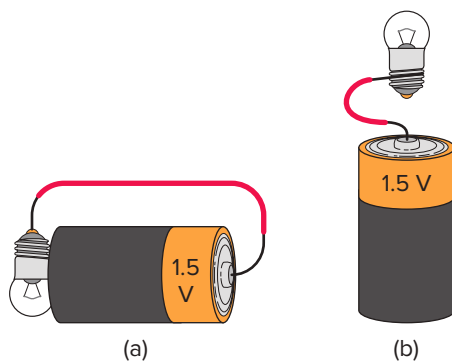
## Conceptual Questions

\* = more open-ended questions, requiring lengthier responses, suitable for group discussion

Q = sample responses are available in appendix D

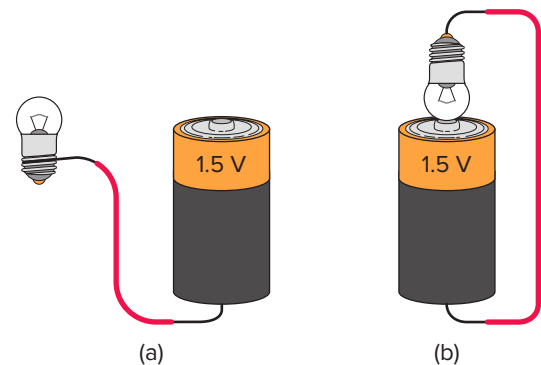
Q = sample responses are available in Connect

Q1. Two arrangements of a battery, bulb, and wire are shown in the diagram. Which of the two arrangements, if either, will light the bulb? Explain.



Q1 Diagram

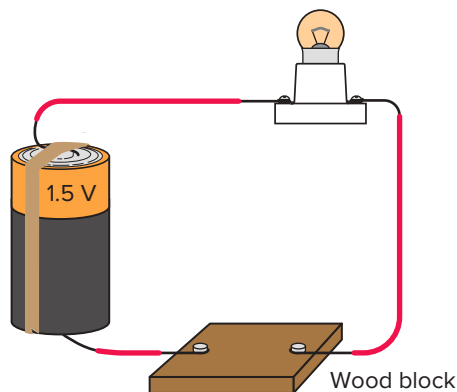
Q2. Suppose you have two wires, a battery, and a bulb. One of the wires is already in place in each of the arrangements shown in the Q2 diagram. Indicate with a drawing where you would place the second wire to get the bulb to light. Explain your decision in each case.



Q2 Diagram

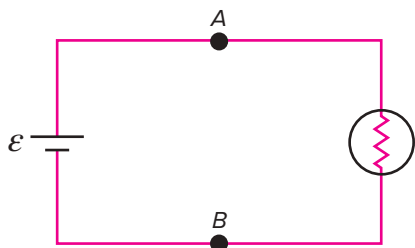
- Q3. In a simple battery-and-bulb circuit, is the electric current that enters the bulb on the side nearer the positive terminal of the battery larger than the current that leaves the bulb on the opposite side? Explain.
- Q4. Are electric current and electric charge the same thing? Explain.
- Q5. When an axon is stimulated, a voltage spike or action potential is created. Does this voltage spike remain stationary or travel down the axon? Explain. (See everyday phenomenon box 13.1.)
- Q6. Does the signal in an axon travel at the same speed as electrical signals in a metal wire? Explain. (See everyday phenomenon box 13.1.) Explain.

Q7. Consider the circuit shown, where the wires are connected to either side of a wooden block, as well as to the lightbulb. Will the bulb light in this arrangement? Explain.



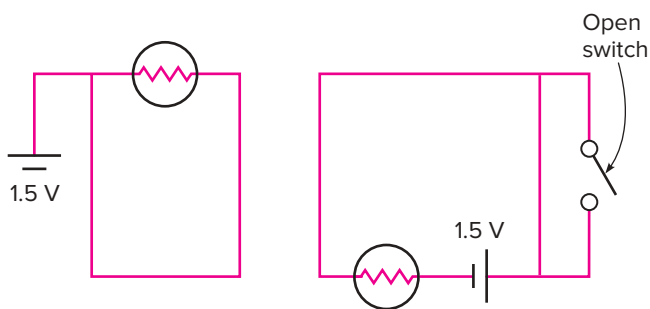
Q7 Diagram

\*Q8. Consider the circuit shown. Could we increase the brightness of the bulb by connecting a wire between points A and B? Explain.



Q8 Diagram

\*Q9. Two circuit diagrams are shown. Which one, if either, will cause the lightbulb to light? Explain your analysis of each case.

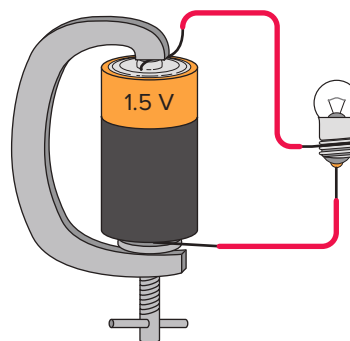


(a)

(b)

Q9 Diagram

Q10. Suppose we use an uncoated metal clamp to hold the wires in place in the battery-and-bulb circuit shown. Will this be effective in keeping the bulb burning brightly? Explain.



Q10 Diagram

Q11. Consider the two signs shown, which are located in different physics labs. Which of the two would be reason for greater caution? Explain.



Q11 Diagram

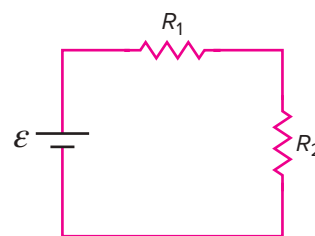
Q12. If we decrease the potential difference across a resistance in a circuit, will the current flowing through that resistance increase, remain the same, or decrease? Explain.

Q13. A dead battery will still indicate a voltage when a good voltmeter is connected across the terminals. Can the battery still be used to light a lightbulb? Explain.

Q14. When a battery is being used in a circuit, will the voltage across its terminals be less than that measured when there is no current being drawn from the battery? Explain.

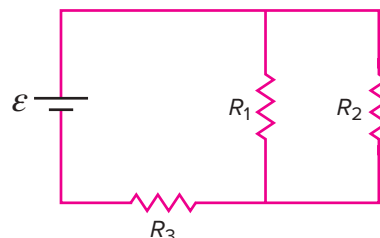
Q15. Two resistors are connected in series with a battery, as shown in the diagram.  $R_1$  is less than  $R_2$ .

- Which of the two resistors, if either, has the greater current flowing through it? Explain.
- Which of the two resistors, if either, has the greatest voltage difference across it? Explain.



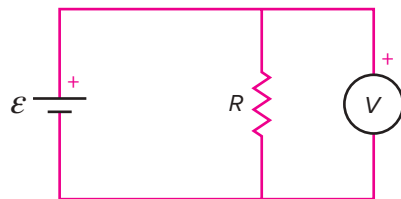
Q15 Diagram

Q16. In the circuit shown in the diagram,  $R_1$ ,  $R_2$ , and  $R_3$  are three resistors of different values.  $R_3$  is greater than  $R_2$ , and  $R_2$  is greater than  $R_1$ .  $\mathcal{E}$  is the electromotive force of the battery whose internal resistance is negligible. Which of the three resistors has the greatest current flowing through it? Explain.



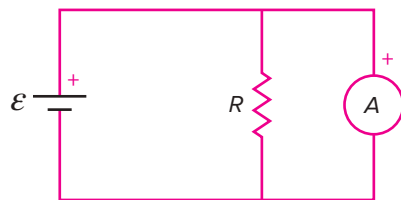
Q16–Q18 Diagram

- \*Q17. In the circuit shown in question 16, which of the three resistors, if any, has the largest voltage difference across it? Explain.
- \*Q18. If we disconnect  $R_2$  from the rest of the circuit shown in the diagram for question 16, will the current through  $R_3$  increase, decrease, or remain the same? Explain.
- Q19. When current passes through a series combination of resistors, does the current get smaller as it goes through each successive resistor in the combination? Explain.
- Q20. In the circuit shown, the circle with a V in it represents a voltmeter. Which of the following statements is correct? Explain.
- The voltmeter is in the correct position for measuring the voltage difference across  $R$ .
  - No current will flow through the meter, so it will have no effect.
  - The meter will draw a large current.



Q20 Diagram

- Q21. In the circuit shown, the circle with an A in it represents an ammeter. Which of these statements is correct? Comment on each.
- The meter is in the correct position for measuring the current through  $R$ .
  - No current will flow through the meter, so it will have no effect.
  - The meter will draw a significant current from the battery.



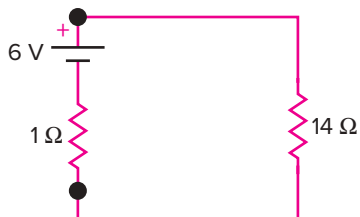
Q21 Diagram

- Q22. Which will normally have the larger resistance, a voltmeter or an ammeter? Explain.
- Q23. Is electric energy the same as electric power? Explain.
- Q24. If the current through a certain resistance is doubled, does the power dissipated in that resistor also double? Explain.
- Q25. Does the power being delivered by a battery depend on the resistance of the circuit connected to the battery? Explain.
- Q26. What energy source increases the potential energy of the water behind the dam of a hydroelectric power plant? Explain.
- \*Q27. Does a battery connected to an electric motor represent a perpetual-motion machine (see chapter 11)? Explain.
- Q28. In using a dc voltmeter, it is important to connect the positive terminal of the meter in the correct direction in the circuit relative to the positive terminal of the battery. Is this likely to be true for the use of an ac voltmeter? Explain.
- Q29. Which of the following appliances is most likely to cause an overload problem when connected to a circuit that already has other appliances drawing current from it: an electric shaver, a coffeemaker, or a TV? Explain.
- Q30. Would it make sense to connect a fuse or circuit breaker in parallel with other elements in a circuit? Explain.
- Q31. Suppose the appliances connected to a household circuit were connected in series rather than in parallel. What disadvantages would there be to this arrangement? Explain.
- Q32. How does a bimetallic strip break a circuit when things heat up? Explain. (See everyday phenomenon box 13.2.)
- Q33. Why does a bimetallic strip bend when the temperature changes? Explain. (See everyday phenomenon box 13.2.)

## Exercises

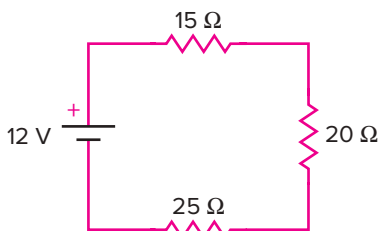
- E1. A charge of 28 C passes at a steady rate through a resistor in a time of 7 s. What is the current through the resistor?
- E2. A current of 4.5 A flows through a battery for 3 minutes. How much charge passes through the battery in that time?
- E3. A  $47\ \Omega$  resistor in a circuit has a voltage difference of 8 V across its leads. What is the current through this resistor?
- E4. A current of 1.5 A is flowing through a resistance of  $30\ \Omega$ . What is the voltage difference across this resistance?
- E5. A current of 0.522 A flows through a resistor with a voltage difference of 115 V across it. What is the resistance of this resistor?
- E6. Four  $22\ \Omega$  resistors are connected in series to an 18-V battery of negligible internal resistance.
- What is the current flowing through each resistor?
  - What is the voltage difference across each resistor?
- E7. A  $47\ \Omega$  resistor and a  $28\ \Omega$  resistor are connected in series to a 12-V battery.
- What is the current flowing through each resistor?
  - What is the voltage difference across each resistor?

- E8. In the circuit shown, the  $1\ \Omega$  resistance is the internal resistance of the battery and can be considered to be in series, as shown, with the battery and the  $14\ \Omega$  load.
- What is the current flowing through the  $14\ \Omega$  resistor?
  - What is the voltage difference across the  $14\ \Omega$  resistor?



E8 Diagram

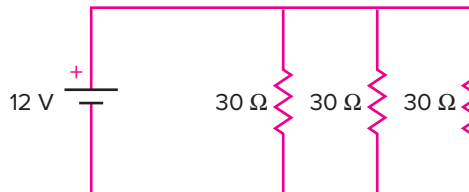
- E9. Three resistors are connected to a 12-V battery as shown. The internal resistance of the battery is negligible.
- What is the total resistance in the circuit?
  - What is the current coming from the battery?
  - What is the current through the  $15\ \Omega$  resistance?
  - Does the same current flow through the  $25\ \Omega$  resistance?
  - What is the voltage difference across the  $20\ \Omega$  resistance?



E9 Diagram

- E10. Two resistors, each having a resistance of  $40\ \Omega$ , are connected in parallel. What is the equivalent resistance of this combination?
- E11. Three resistors of  $9\ \Omega$ ,  $12\ \Omega$ , and  $15\ \Omega$  are connected in parallel with one another. What is the equivalent resistance of this combination?

- E12. Three identical resistances, each  $30\ \Omega$ , are connected in parallel with one another as shown. The combination is connected to a 12-V battery whose internal resistance is negligible.
- What is the equivalent resistance of this parallel combination?
  - What is the total current through the combination?
  - How much current flows through each resistor in the combination?

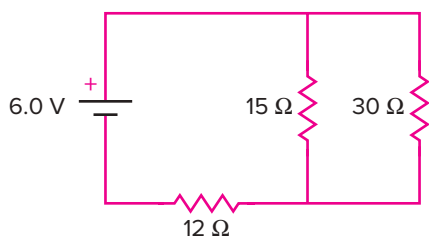


E12 Diagram

- E13. A 9-V battery in a simple circuit produces a current of  $1.5\ \text{A}$  through the circuit. How much power is being delivered by the battery?
- E14. An  $80\ \Omega$  resistor has a voltage difference of  $12\ \text{V}$  across its leads.
- What is the current through the resistor?
  - What is the power being dissipated in this resistor?
- E15. A 75-W lightbulb operates on an effective ac voltage of  $110\ \text{V}$ .
- What is the effective current through the lightbulb?
  - From Ohm's law, what is the resistance of the lightbulb?
- E16. A toaster draws a current of  $9.0\ \text{A}$  when it is connected to a  $110\text{-V}$  ac line.
- What is the power consumption of this toaster?
  - What is the resistance of the heating element in the toaster?
- E17. A clothes dryer uses  $6600\ \text{W}$  of power when connected to a  $220\text{-V}$  ac line. How much current does the dryer draw from the line?

## Synthesis Problems

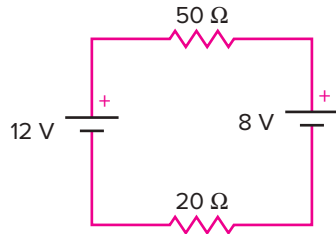
- SP1. In the circuit shown, the internal resistance of the battery can be considered negligible.
- What is the equivalent resistance of the two-resistor parallel combination?
  - What is the total current flowing through the battery?
  - What is the voltage drop across the 12-ohm resistor?
  - What is the voltage drop across the 15-ohm resistor?
  - What is the current flowing through the  $15\ \Omega$  resistor?
  - What is the power dissipated in the  $12\ \Omega$  resistor?
  - Is the current flowing through the  $12\ \Omega$  resistor greater or less than that flowing through the  $15\ \Omega$  resistor? Explain.



SP1 Diagram

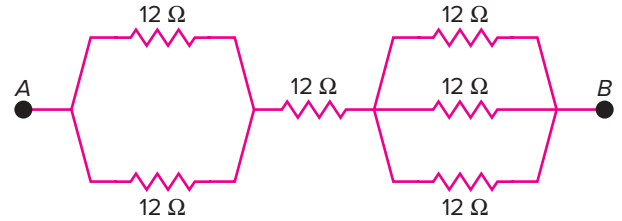
- SP2. Three  $36\ \Omega$  lightbulbs are connected in parallel to an  $18.0\text{-V}$  battery with negligible internal resistance.
- What is the current flowing through the battery?
  - What is the current flowing through each bulb?
  - If one bulb burns out, does the brightness of the other two bulbs change? Explain.
- SP3. In the circuit shown, the 8-V battery is opposing the 12-V battery as they are positioned. The total voltage of the two batteries will be found by subtracting.
- What is the current flowing around the circuit?
  - What is the voltage difference across the  $20\ \Omega$  resistor?
  - What is the power delivered by the 12-V battery?

- d. Is the 12-V battery discharging or charging in this arrangement?



**SP3 Diagram**

- SP4. In the combination of  $12\ \Omega$  resistors shown in the diagram, there are two different parallel combinations that, in turn, are in series with the middle resistor.
- What is the resistance of each of the two parallel combinations?
  - What is the total equivalent resistance between points  $A$  and  $B$ ?
  - If there is a voltage difference of  $18\ \text{V}$  between points  $A$  and  $B$ , what is the current flowing through the entire combination?



**SP4 Diagram**

- SP5. An 850-W toaster, a 1200-W waffle iron, and a 1000-W coffeemaker are all connected to the same 115-V household circuit, fused at 20 A. (See figure 13.19 for a similar arrangement.)
- What is the current drawn by each of these appliances?
  - If these appliances are all turned on at the same time, will there be a problem? Explain.
  - What is the resistance of the heating element in the waffle iron?

## Home Experiments and Observations

- HE1. If you have a flashlight handy, you have a working example of a simple battery-and-bulb circuit.
- Open the flashlight and remove the batteries and bulb. Can you see how the switch operates? What makes contact when the switch is closed? Sketch the switch to make this clear.
  - How are the connections made to the bulb in the flashlight?
  - Leaving the bulb in its socket, can you get it to light by using external wires to make connections to the batteries? Sketch the arrangement that works.
- HE2. If you have two flashlight bulbs, a flashlight battery, and some wires available, you can try your hand at building your own series and parallel circuits. The wires can be looped around the side of the bulb to hold the bulbs, and the contact with the base may be made to any metal object to which you can touch another wire. The bulb sockets from a flashlight may be useful.
- Construct a circuit with the two bulbs in series with one another and with the battery. Note the brightness of the bulbs when they are lit. (They may barely be glowing if you are using just one battery.)
  - Now construct a circuit with the two bulbs in parallel with one another. Note the brightness of the bulbs in this case.
  - Construct a circuit with just one bulb and compare the brightness of the bulb in this situation to the brightness noted in parts a and b.
- HE3. Some lightbulbs are designed to operate at three different brightness levels. Locate such a bulb either in your home or residence hall, or in a local store.
- Unscrew the bulb from the socket and examine the base of the bulb. Sketch carefully the points at which electrical contact can be made with the base of the bulb.
  - Unplug the lamp* and examine the socket. How does it make electrical contact with the bulb? (If you do not have such a lamp handy, your local hardware store will have three-way sockets for sale that you can examine.)
  - If you can see inside the bulb, how many filaments can you identify?
  - Develop an explanation for how the bulb can produce three different brightness levels depending on the switch position.
- HE4. Locate all of the electric appliances you use in your residence-hall room or in a single room in your house.
- Can you find current or power ratings on these appliances? What are they?
  - Even if power ratings cannot be found for each device, can you guess (with the help of table 13.2) approximately how much current each appliance is likely to draw? Rank the appliances in order from the one likely to draw the most current to the one that would draw the least.
  - Is there likely to be a problem if all of the appliances are turned on at the same time on a single circuit fused at 20 A?





Stockbyte/Getty Images

## Magnets and Electromagnetism

### Chapter Overview

After a description of the behavior of magnets that builds on similarities to the electrostatic force, we explore the relationship between electric currents and magnetic forces. We then introduce Faraday's law, which describes how electric currents can be generated by interaction with magnetic fields (electromagnetic induction). Our main objectives will be to get a grasp of the nature of magnetic forces and fields and of Faraday's law of electromagnetic induction.

### Chapter Outline

- 1 Magnets and the magnetic force.** What are the poles of a magnet? How is the magnetic force similar to the electrostatic force? Why does a compass work, and what is the nature of the Earth's magnetic field?
- 2 Magnetic effects of electric currents.** What is the relationship between electric currents and magnetic forces and fields? How can we describe the magnetic force in terms of moving charges?
- 3 Magnetic effects of current loops.** What are the magnetic characteristics of current loops? In what way is a loop of electric current like a bar magnet?
- 4 Faraday's law: Electromagnetic induction.** How can electric currents be produced using magnetic fields? What is Faraday's law of electromagnetic induction?
- 5 Generators and transformers.** How can Faraday's law be used to explain how electric generators and transformers work? What roles do these devices play in the production and transmission of electric power?

**D**o you remember playing with refrigerator magnets as a child? Plastic letters and figures, backed with small magnets, can be arranged at your pleasure on the refrigerator door. They stick to the steel door because of the magnets, a fact you have accepted since you were four years old or so. They are a wonderful teaching tool, as well as a plaything, because the letters can be arranged to spell simple words (fig. 14.1).

Because of such toys, we are generally more familiar with magnetic forces than with electrostatic forces. We have played with small horseshoe magnets and compasses—maybe even with simple *electromagnets* made from a steel nail, some wire, and a battery. We know there is a force that attracts some types of metal, but not others, to magnets. Like the gravitational force and the electrostatic force, this force acts even when the objects are not in direct contact with one another.

Although the magnetic force is familiar, it can also seem mysterious. Beyond these simple facts just listed, your understanding of the magnetic force is likely to be limited. In what ways is it like the electrostatic force, and how does it differ? On a more fundamental level, is there a relationship between electrical effects and magnetism? Our mention of electromagnets hints at such a connection.

There is indeed a connection between electric currents and magnetic forces. These relationships were discovered in the early nineteenth century and culminated in a theory of electromagnetism developed during the 1860s by Scottish physicist James Clerk Maxwell. In the early part of the twentieth century, it became clear that the electrostatic force and



**Figure 14.1** A child playing with magnet-backed letters that stick to the refrigerator door. What is the force that holds the letters to the door?

Bob Coyle/McGraw-Hill Education

the magnetic force are really just different aspects of one fundamental electromagnetic force.

Our understanding of the relationships between electricity and magnetism has led to numerous inventions that play enormous roles in modern technology. These include electric motors, electric generators, transformers, and many other devices.

## 14.1 Magnets and the Magnetic Force

If you gather up a few magnets from around the home or office (fig. 14.2), you can establish basic facts about their behavior with some simple experiments. You probably already know that magnets attract paper clips, nails, and any other metallic item made of iron or steel. They do not attract items made of silver, copper, or aluminum or *most* nonmetallic materials. Magnets also attract each other but only if the ends are properly aligned. If the ends are not properly aligned, the force between them is repulsive rather than attractive.

The three common magnetic elements are the metals iron, cobalt, and nickel. The small magnets for sticking things to refrigerator doors or metal cabinets are alloys of iron, with other elements added to obtain desired properties. Many small, powerful magnets today are neodymium magnets made from a combination of niobium, iron, and boron. The first known magnets were a form of iron ore called *magnetite*, which occurs naturally and is often weakly magnetized. The existence of magnetite was known in antiquity, and its properties had long been a source of curiosity and amusement.

### What are magnetic poles?

If you look closely at some of the magnets in your collection, you may find their ends labeled with the letters *N* and *S*



**Figure 14.2** A collection of magnets. Where are the poles likely to be found on each magnet?

Bob Coyle/McGraw-Hill Education

for *north* and *south*. If we explored the origin of these labels, we would discover that they originally stood for *north-seeking* and *south-seeking*. If you suspend a simple bar magnet by a thread tied around its middle and allow it to turn freely about the point of suspension, it eventually comes to rest with one end pointing approximately northward. This is the end, or **magnetic pole**, that we label *N*; the other is then labeled *S*.

If your magnets are labeled in this manner, you will quickly discover that the opposite poles of two magnets attract each other. The north pole of one attracts the south pole of the other. If you hold the magnets firmly in each hand and bring two north poles near each other, you can feel a repulsive force pushing them apart. The same is true of two south poles. In fact, if one of the magnets is lying on the table and you try to bring two like poles together, the magnet on the table will suddenly flip around, so that the opposite pole comes into contact with the pole of the approaching magnet.

These simple observations can be summarized in a rule that you probably first learned as part of a science unit in grade school (fig. 14.3):

Like poles repel each other and unlike poles attract each other.

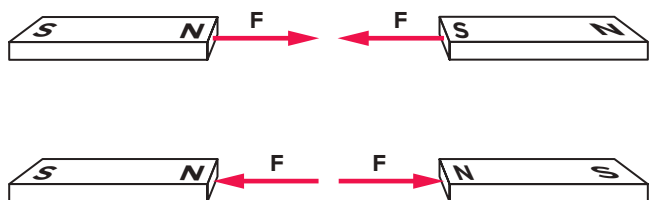
There is an obvious similarity here to the rules for the electrostatic forces between like and unlike charges. (See section 12.1.) The rule for magnets, however, was known well before the electrostatic rule.

It is fun to play with magnets, chasing them around with each other. Small disk or ring magnets usually have their poles on opposite sides of the disk. If you bring a small bar magnet nearby with like poles facing each other, the disk may hop away or do a quick flip and attach itself to the bar magnet. Sometimes, the flip is so quick it is difficult to see. If the magnets are shaped like small rings, you can get them to levitate easily on a thin wooden post, as shown in figure 14.4.

Some magnets seem to have more than two poles: there may be a south and north pole somewhere in the middle of the magnet. Iron filings sprinkled on a piece of paper lying on top of the magnet will show where its poles are. The filings will group most densely near the poles (fig. 14.5).

### The magnetic force and Coulomb's law

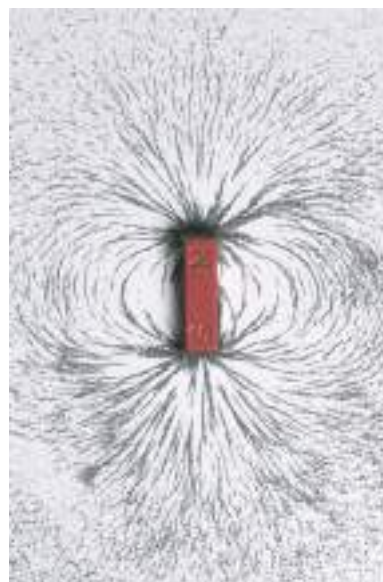
The similarity between the behavior of magnetic poles and electrostatic charges goes well beyond the rules for attraction and repulsion. If we attempt to measure how the force that two poles exert on each other varies with distance or pole strength, we find a behavior similar to Coulomb's law for the electrostatic force. In fact, Coulomb himself made the initial measurements and first stated the force law for magnets.



**Figure 14.3** Unlike poles attract each other, and like poles repel each other.



**Figure 14.4** Ring magnets levitating on a vertical wooden rod. The rod keeps the magnets from flying off to the side.  
*Lars A. Niki/McGraw-Hill Education*



**Figure 14.5** Thin iron filings can be used to visualize the magnetic field around a simple bar magnet.  
*Lars A. Niki/McGraw-Hill Education*

Coulomb made his measurements with magnets by substituting long, thin bar magnets for the metal balls in his torsion balance (see section 12.3). The magnets have to be long, so that the opposite poles are far enough away from the point of measurement that their effect on the force can be ignored.

Coulomb's experiments showed that the magnetic force between two poles decreases with the square of the distance

between the two poles, just as the electrostatic force does. The force is also proportional to a quantity called the *pole strength* of each pole. Some magnets are stronger than others, and the magnitude of the force exerted by one magnet on the other depends on the pole strength of both magnets.

### Can we associate field lines with magnets?

A magnet is always at least a **magnetic dipole**: We cannot completely isolate a *single* magnetic pole. A dipole consists of two opposite poles separated by some distance. Although there can be more than two poles, apparently there can never be fewer than two. Physicists have invested considerable effort looking for **magnetic monopoles** (particles consisting of a single, isolated magnetic pole), but there is no conclusive evidence that they exist. Breaking a magnetic dipole in half always produces two dipoles.

In this one respect, then, magnetic poles are *not* similar to electric charges. Positive and negative charges can be isolated. Electric dipoles do exist, consisting of equal but opposite charges separated by a small distance, as in figure 14.6. The electric field lines produced by an electric dipole originate on the positive charge and end on the negative charge.

Does a magnetic dipole have similar field lines? We can indeed define a *magnetic field* whose field lines for a magnetic dipole are similar to the electric field lines for an electric dipole. (The definition of magnetic field is considered in more detail in section 14.2.) The magnetic field lines emerge from the north pole of the dipole and go into the south pole (fig. 14.6). Unlike electric field lines, however, the magnetic field lines do not end—they form continuous loops. You can make this pattern visible by sprinkling iron filings on a piece of paper covering a bar magnet. The filings line up in the direction of the field, as shown in figure 14.5.

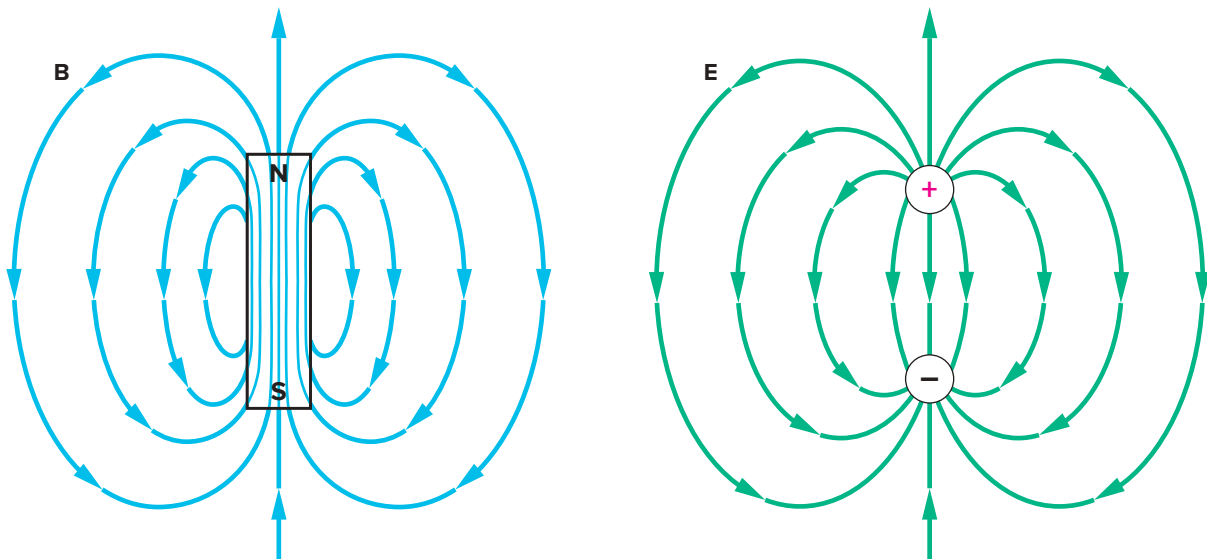
If we place an electric dipole in an electric field produced by other charges, the dipole will line up with this field. The forces acting on each charge in the dipole combine to produce a torque on the dipole that turns it toward the direction of the field (fig. 14.7). Similarly, a magnetic dipole lines up with an externally produced magnetic field. This is why iron filings line up with the field lines around a magnet. The filings become magnetized in the presence of the field—each one becomes a small magnetic dipole.

### Is the Earth a magnet?

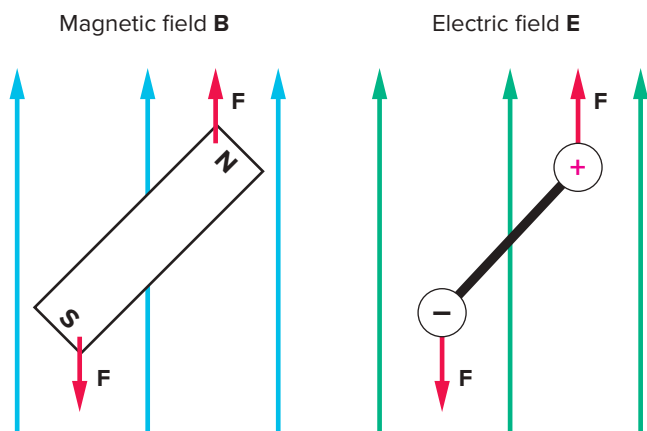
A compass needle is a magnetic dipole. The first compasses were made by balancing a thin crystal of magnetite on a support, so that it could turn freely. As you are aware, the north (or north-seeking) pole of the magnet will point north, although not exactly due north. The invention of the compass became a tremendous aid to ocean navigation in the early Renaissance. Before then, sailors were unable to navigate on cloudy days or nights when they could not see the sun or stars.

Is the Earth a magnet? What kind of magnetic field is the compass needle responding to? The compass was invented by the Chinese, but an English physician named William Gilbert (1540–1603) was the first to study these phenomena thoroughly. Gilbert suggested that the Earth behaves like a large magnet. You can picture the magnetic field produced by the Earth by imagining that inside the Earth there is a large bar magnet oriented as shown in figure 14.8. (Do not take this picture literally. It is merely a device for describing the field.)

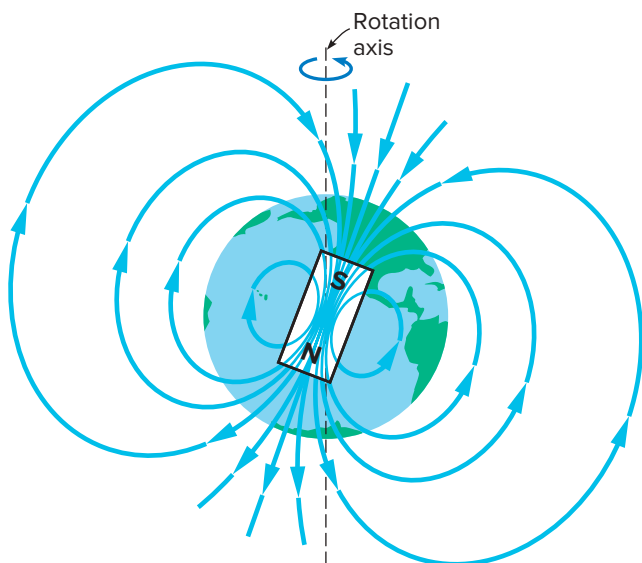
Because unlike poles attract, the south pole of the Earth's magnet must point in a northerly direction. The north-seeking pole of the compass aligns itself northward along the field lines produced by the Earth. The axis of the Earth's



**Figure 14.6** Magnetic field lines produced by a magnetic dipole form a pattern similar to that of the electric field lines produced by an electric dipole. However, the magnetic field lines form continuous loops.



**Figure 14.7** A magnetic dipole lines up with an externally produced magnetic field, just as an electric dipole lines up with an electric field.



**Figure 14.8** The magnetic field of the Earth can be pictured by imagining a bar magnet inside the Earth (there is not one, of course), oriented as shown here.

magnetic field, though, is not aligned exactly with the Earth's axis of rotation. Because the rotational axis defines geographic, or true, north, the compass needle does not point exactly north at most locations. On the east coast of the United States, magnetic north is a few degrees to the west of true north, while on the west coast it is several degrees to the east of true north. Somewhere in the middle of the United States, magnetic north and true north are identical. The precise location of this line varies slowly with time. Sometimes, the Earth's magnetic poles flip: The North and South Poles swap places. The last time this happened was approximately 780,000 years ago, a relatively short time on a geologic timescale. These reversals are recorded in the magnetism of ancient rocks.

We do not know exactly how the Earth's magnetic field is produced, although models have been developed that account for many of its features. Most of these models assume that electric currents associated with the motion of fluids in the Earth's core are responsible. But what do electric currents have to do with magnetic fields?

Simple magnets have two poles, usually labeled north and south, which obey force rules like those for electric charges. Like poles repel and unlike poles attract, and the force exerted by one on another is inversely proportional to the square of the distance between them. As far as we know, isolated magnetic monopoles do not exist: The simplest magnet is a dipole. Magnetic field lines for a magnetic dipole form a pattern similar to that of the electric field lines for an electric dipole. The Earth itself resembles a large magnetic dipole, with its south magnetic pole pointing more or less northward.

## 14.2 Magnetic Effects of Electric Currents

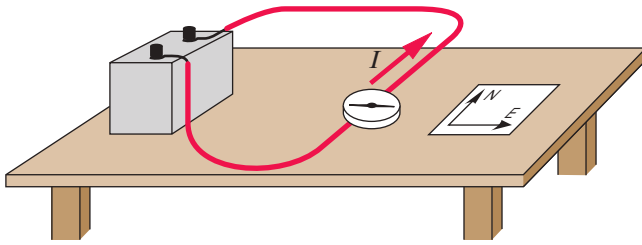
The invention of the battery by Volta in 1800 made it possible to produce steady electric currents for the first time. Previously, currents could be produced only as rapid discharges of charge accumulated in electrostatic experiments. Connecting a long, thin wire across the terminals of Volta's battery permitted a much steadier flow of charge. Scientists were then able to study electric currents in ways not previously possible.

The similarities between magnetic and electrostatic effects discussed in section 14.1 led scientists to suspect that a direct connection between electricity and magnetism might exist. The same people were often involved in the study of both areas. William Gilbert explored electrostatic effects, as well as magnetism, and Charles Coulomb measured the force law for both magnetic poles and electric charges. Twenty years after the invention of the battery, a striking discovery was made by Danish scientist Hans Christian Oersted (1777–1851).

### An unexpected effect

Oersted's initial discovery of the magnetic effect of an electric current was made during a lecture demonstration in 1820. Demonstrations often fail to go exactly as planned, but this is one case when failure was fortuitous. Oersted was showing the effects of electric currents and happened to have a compass handy. He noticed that the compass needle deflected when he completed a circuit consisting of a long wire and a battery.

Oersted had used a compass near a current-carrying wire before but had not noticed any effect. Other scientists had also looked for such effects without success, so the deflection of the compass needle during Oersted's lecture was unexpected.



**Figure 14.9** With the wire oriented along a north-south line, the compass needle deflects away from this line when there is current flowing in the wire.

Not wishing to make a fool of himself in front of his students, he decided to explore the situation more carefully after the lecture was over. He found a reproducible effect on the compass needle, as long as the current was sufficiently strong and the compass and wire were situated in certain ways.

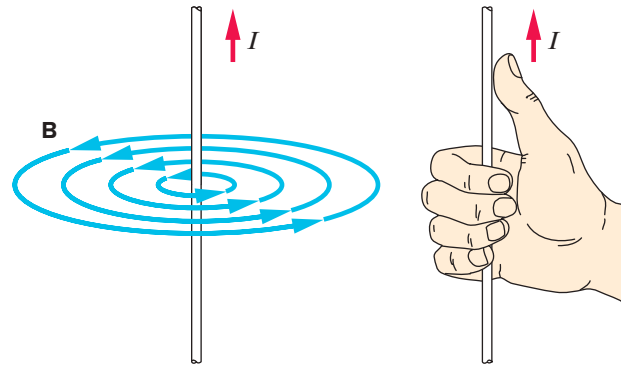
The strange directional aspects of this newly discovered effect may explain why it had not been observed earlier. To get the maximum effect with a horizontal wire, the wire must be oriented along a north-south line (along which the compass needle would point in the absence of current). When the current is turned on, the needle deflects away from north (fig. 14.9). Apparently, the magnetic field produced by the current in the wire is *perpendicular* to the direction of the current.

Further study by Oersted and others showed that the magnetic field lines produced by a straight, current-carrying wire form circles centered on the wire. Oersted did not talk about field lines but about the direction the compass needle pointed at various locations. When he placed the compass below the wire, the needle deflected in the opposite direction from the direction it faced when it was above the wire. A simple right-hand rule describes the direction of the field. If you imagine holding the wire in your right hand with your thumb pointing in the direction of the electric current, your fingers curl around the wire in the direction of the magnetic field lines (fig. 14.10).

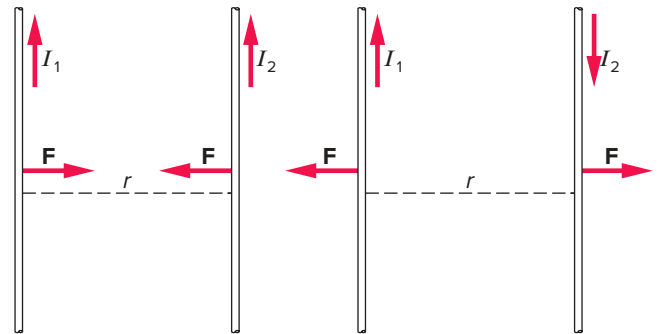
Not surprisingly, the effect gets weaker as the compass is moved away from the wire. A current of a few amperes is needed to get a large deflection of the compass needle even when the compass is just a few centimeters from the wire. Early batteries were not capable of sustaining large currents. This limitation, together with the unexpected direction of the effect, probably delayed its discovery.

### The magnetic force on a current-carrying wire

If we can produce magnetic fields with electric currents, do currents behave like magnets in other respects? Does an electric current experience a magnetic force in the presence of a magnet or another current-carrying wire? This question was explored by many scientists who were excited by Oersted's discovery, including André Marie Ampère in France.



**Figure 14.10** The right-hand rule gives the direction of the magnetic field lines that encircle a current-carrying wire. The thumb points in the direction of the current, and the fingers curl in the direction of the field lines.



**Figure 14.11** Two parallel current-carrying wires exert an attractive force on each other when the two currents are in the same direction and a repulsive force on each other when the two currents are in opposite directions.

Ampère discovered that there is indeed a force exerted on one current-carrying wire by another. He carefully demonstrated that this force is related to the magnetic effect discovered by Oersted and cannot be explained as an electrostatic effect. A current-carrying wire is usually electrically neutral, with no net positive or negative charge. Ampère measured the strength of the magnetic force between two parallel current-carrying wires and studied how it varies with the distance between the wires and the amount of current flowing in each (fig. 14.11).

Ampère's experiments showed that the magnetic force between two parallel wires is proportional to the two currents ( $I_1$  and  $I_2$ ) and inversely proportional to the distance  $r$  between the two wires. We usually state this relationship as

$$\frac{F}{l} = \frac{2k'I_1I_2}{r}$$

where the constant  $k'$  is equal to  $1 \times 10^{-7} \text{ N/A}^2$ , and  $F/l$  represents the force per unit length of the wire. The longer the wires, the greater the force. The force exerted by one wire on the other is attractive when the currents are flowing in the same direction and repulsive when the currents are flowing in opposite directions.

The strangely simple value of the constant  $k'$  is no accident. We define the unit of current, the ampere, by using this relationship and measuring the force between two current-carrying wires:

One ampere (A) is the amount of current flowing in each of two parallel wires separated by a distance of 1 meter that produces a force per unit length on each wire of  $2 \times 10^{-7}$  N/m (newtons per meter).

The ampere is the basic unit of electromagnetism. It is standardized by making measurements of the magnetic force between two wires. The coulomb is defined from the ampere. Because current is defined as charge per unit time ( $I = q/t$ ), charge is the product of current multiplied by time ( $q = It$ ). Therefore, 1 coulomb equals 1 ampere-second ( $1 \text{ C} = 1 \text{ A} \cdot \text{s}$ ).

## Study Hint

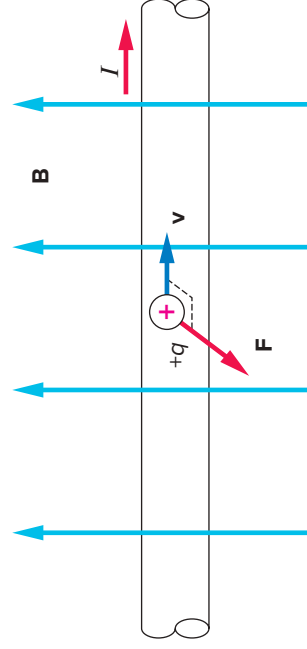
Although these equations may seem overwhelming, use them to help you with the conceptual ideas. For example, when looking at the force per unit length felt between two wires, ask yourself, Does the force increase if the distance increases? Does the force change if the current increases? Use the equation to guide your thinking.

## The magnetic force on a moving charge

What, then, is the basic nature of the **magnetic force**? Magnetic forces are exerted by magnets on other magnets (section 14.1), by magnets on current-carrying wires, and by current-carrying wires on each other. Because electric current is the flow of electric charge, we apparently obtain magnetic forces when charges are moving. Is the motion of charge somehow a fundamental criterion for magnetic forces to exist? Ampère also addressed this question during the 1820s.

Think about the direction of the force exerted by one current-carrying wire on another: This force is perpendicular to the direction of the current. Because the direction of electric current is the direction of flow of positive charge, we might suppose that a magnetic force is exerted on the moving charges in the wire. This force must be perpendicular to the velocity of the charges to be consistent with the observed force on a given wire (fig. 14.12).

The magnetic force on a current-carrying wire has its maximum value when the wire is perpendicular to the direction of the magnetic field. All these facts suggest that a magnetic force is exerted on a moving charge. This force is proportional to the quantity of the charge and the velocity of the moving charge (which are related to the current for the charges flowing in the wire) and to the strength of the magnetic field. In symbols, we write this as  $F = qvB$ , where  $q$  is the charge,  $v$  is the velocity of the charge, and  $B$  is the strength of the magnetic field. For this relationship to be



**Figure 14.12** The magnetic force exerted on the moving charges of an electric current is perpendicular both to the velocity of the charges and to the magnetic field.

valid, however, the velocity must be perpendicular to the field. The charge need not be confined in a wire, however.

This expression for the magnetic force actually defines the magnitude of the magnetic field. Dividing by  $q$  and  $v$ , it can be put in the form

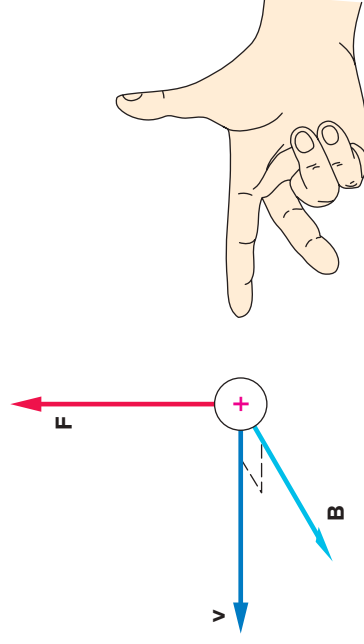
$$B = \frac{F}{qv_{\perp}}$$

where  $v_{\perp}$  stands for the component of the velocity that is perpendicular to the field, in units of m/s. From this definition, the unit of magnetic field is equal to 1 newton per ampere-meter ( $\frac{\text{N}}{\text{A} \cdot \text{m}}$ ), which is now called a *tesla* (T).

Just as electric field is the electrostatic force per unit of charge, the **magnetic field** is the magnetic force per unit of charge and unit of velocity. If the velocity of the charge is zero, there is no magnetic force, but the magnetic field may still be present. The magnetic field is the force per unit charge and unit velocity that would be exerted if a *moving* charge were present with its velocity perpendicular to the magnetic field.

## What is the direction of the magnetic force on a moving charge?

Another right-hand rule, illustrated in figure 14.13, is often used to describe the direction of the magnetic force on a moving charge. If you point the index finger of your right hand in the



**Figure 14.13** If the index finger of the right hand points in the direction of the velocity of the charge, and the middle finger in the direction of the magnetic field, the thumb indicates the direction of the magnetic force acting on a positive charge.

## Example Box 14.1

### Sample Exercise: Magnetic Force

A straight wire with a length of 15 cm carries a current of 4 A. The wire is oriented perpendicularly to a magnetic field with a magnitude of 0.5 T. What is the size of the magnetic force exerted on the wire?

$$\begin{aligned} l &= 15 \text{ cm} = 0.15 \text{ m} & F &= IlB \\ I &= 4 \text{ A} & &= (4 \text{ A})(0.15 \text{ m})(0.5 \text{ T}) \\ B &= 0.5 \text{ T} & &= 0.3 \text{ N} \end{aligned}$$

(The direction of this force will be perpendicular both to the current in the wire and to the magnetic field, as described by the right-hand rule in fig. 14.13.)

direction of the velocity of a *positive* charge, and the middle finger in the direction of the magnetic field, the thumb points in the direction of the magnetic force on the moving charge. This force is always perpendicular to both the velocity and the field direction. The force on a negative charge is in the opposite direction of a positive charge moving in the same direction.

Because the magnetic force on a moving charge is perpendicular to the velocity of the charge, this force does no work on the charge and cannot increase its kinetic energy. The resulting acceleration of the charge is a centripetal acceleration (as discussed in chapter 5) that changes the direction of the charge's velocity. If the charge is moving in a direction perpendicular to a uniform magnetic field, the magnetic force will bend the path of the charged particle into a circle. The radius of the circle is determined by the mass and speed of the particle and can be found by applying Newton's second law. (See synthesis problem 2.)

Because the direction of electric current is the same as the flow of positive charge, the right-hand rule used to find the direction of the force on a moving charge can also be used to describe the direction of the force on a current-carrying wire. In this case, the index finger points in the direction of the current, and the middle finger and the thumb have the same meanings as before.

The magnetic force on a segment of wire can be expressed in terms of the magnetic field as  $F = IlB$ , where  $I$  is the current,  $l$  is the length of the segment of wire, and  $B$  is the strength of the magnetic field (see example box 14.1). The direction of the current must be perpendicular to the field for this expression to be valid. This expression is merely another way of writing the relationship  $F = qvB$ . The product of the charge times the velocity ( $qv$ ) is replaced by the product of the current times the length of the segment of wire ( $Il$ ).

The magnetic force is exerted by *moving* charges on one another. Because electric currents are moving charges, we can also say that the magnetic force is a force exerted by electric currents on one another, and we can always replace the product  $qv$  with the product  $Il$  in expressions involving magnetic fields or forces.

Oersted discovered that when properly oriented, an electric current can cause a deflection of a compass needle. Following up on this discovery, Ampère showed that a magnetic force is exerted on one current-carrying wire by another. Because an electric current consists of moving charges, the size of a magnetic field can be defined as the force per unit charge per unit velocity of the charge, provided that the velocity is perpendicular to the magnetic field.

## 14.3 Magnetic Effects of Current Loops

Up to this point, the current-carrying wires that we have considered have been straight, although they must bend somewhere to complete an electric circuit. Many applications of electromagnetism involve loops of wire. Wire coils are used in electromagnets, electric motors, electric generators, transformers, and a host of other applications.

What happens when we bend a current-carrying wire into a coil? What does the magnetic field look like, and how is the coil affected by other magnetic fields? The intense experimental activity of the 1820s following Oersted's discovery explored these questions. Ampère, as well as many other scientists, was active in this work.

### The magnetic field of a current loop

As discussed in section 14.2, the magnetic field lines around a straight wire form circles centered on the wire. Imagine the process of bending such a wire into a circular loop: What happens to the field lines? Very near the wire, the field lines presumably are still circles. Toward the center of the loop, however, the field contributions produced by different segments of the wire are all approximately in the same direction. They add to give a strong field at the center.

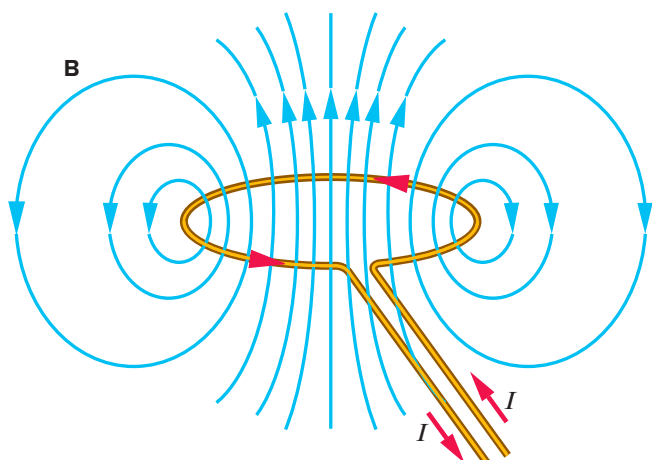
The resulting field is depicted in figure 14.14. The field lines are close together near the center of the loop, indicating a strong field. The field is also strong near the wire itself. Farther from the loop, the field weakens, as should be expected. Like the field lines for a straight wire, the magnetic field lines for the current loop curve around until they meet themselves, forming closed loops.

Note that the field shown in figure 14.14 resembles the field of a bar magnet (see fig. 14.6). In fact, if the bar magnet is short enough, as in figure 14.15, the field patterns are identical. We might conclude that a current loop is a magnetic dipole, because its field is the same as the more familiar dipole, the bar magnet.

### Is there a magnetic torque on a current loop?

The similarity between a current loop and a bar magnet goes beyond the fields produced. If you place a current loop in an





**Figure 14.14** When a current-carrying wire is bent into a circular loop, the magnetic fields produced by different segments of the wire add to produce a strong field near the center of the loop.

external field, it experiences a torque, just as a bar magnet would if it were not initially aligned with the field. It is possible to use a loop or several loops of current-carrying wire as a compass needle, because its axis (perpendicular to the plane of the loop) would line up with an external field, just as a normal compass needle does.

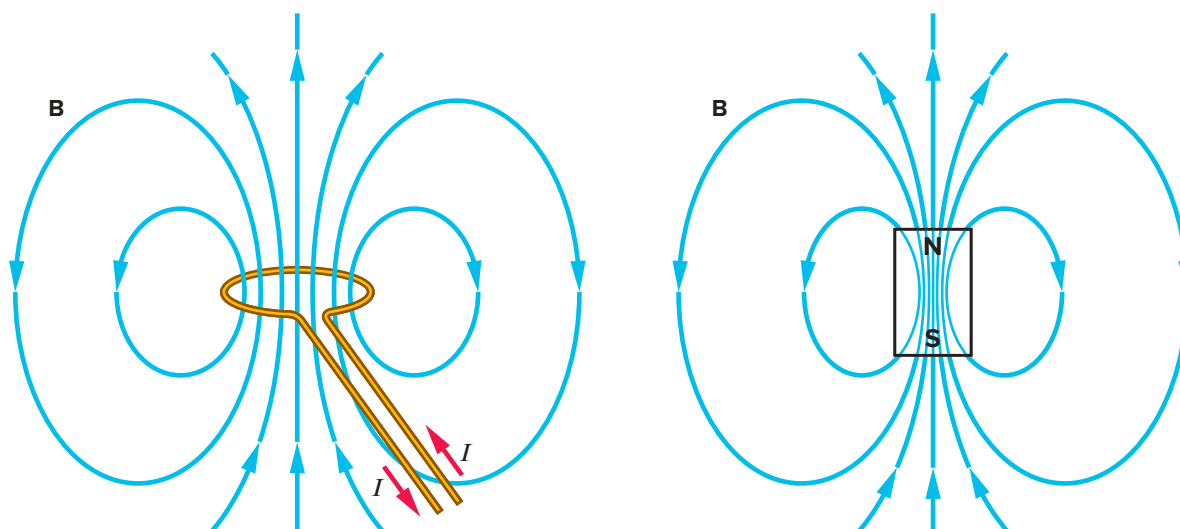
We can see the origin of the torque on a current loop most readily by considering a loop in the form of a rectangle, as in figure 14.16. Each segment of the rectangular loop is a straight wire, and the force on each segment is given by the expression  $F = I\ell B$ , introduced in section 14.2. The directions of the forces are given by the right-hand rule in figure 14.13. Limber up your right hand, and verify the force directions in the diagram.

Each of the four sides of the loop in figure 14.16 experiences a magnetic force. The forces on the two ends of the loop ( $F_1$  and  $F_2$ ) produce no torque about the center of the loop, because their lines of action pass through the center of the loop. Their lever arms about any axis passing through the center of the loop are zero, and they produce no torque about the center. (See chapter 8 for a discussion of torque and rotational motion.)

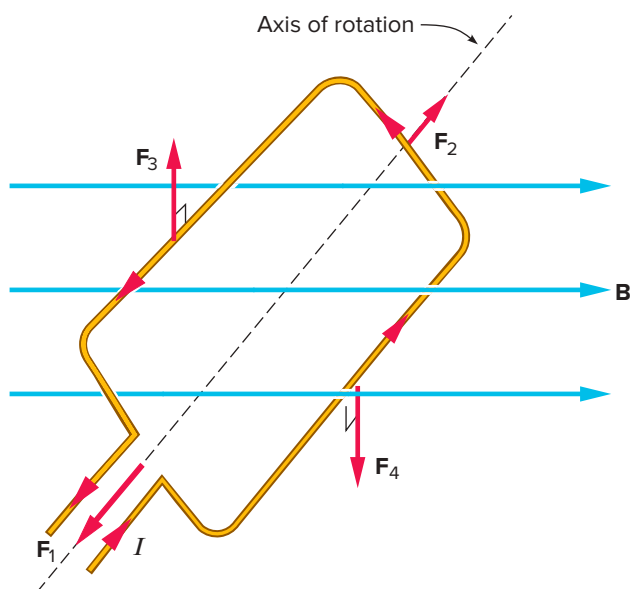
The forces on the other two sides ( $F_3$  and  $F_4$ ) have lines of action that do not pass through the center of the loop, provided that the plane of the loop is not perpendicular to the external magnetic field. From the diagram, we see that these two forces combine to produce a torque that tends to rotate the loop about the axis shown, so that its plane ends up perpendicular to the magnetic field.

Because the magnetic forces on the loop segments are proportional to the electric current flowing around the loop, the magnitude of the torque on the loop is also proportional to the current. This fact makes the torque on a current-carrying coil useful for measuring electric current. Most simple ammeters have a coil of wire with a needle attached to it at their center. A permanent magnet provides the magnetic field, and a spring returns the needle to zero when there is no current (fig. 14.17).

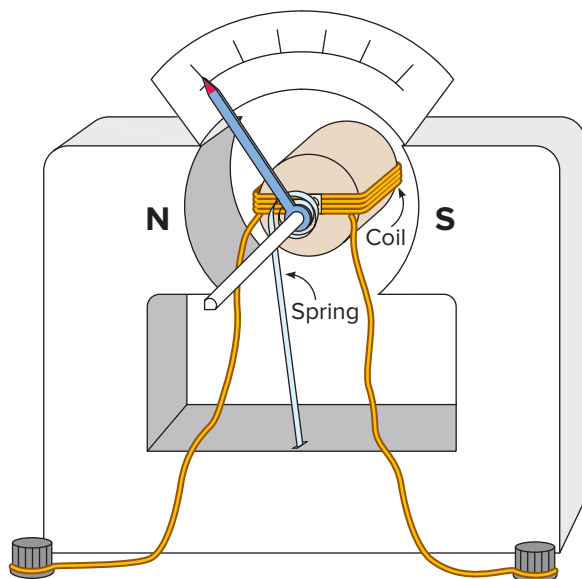
This torque is also the basis of operation for electric motors. To keep the coil turning, however, the current in the coil must reverse directions every half turn. Otherwise, the coil would come to rest with the plane of its loop perpendicular to the external magnetic field. An alternating current is well suited to operating electric motors, but we can also design motors that operate on direct current (see everyday phenomenon box 14.1). Electric motors are found everywhere, from the starting motor in your car to the motors in kitchen appliances, vacuum cleaners, washers and dryers, and electric shavers.



**Figure 14.15** The magnetic field produced by a current loop is very similar to one produced by a short bar magnet (a magnetic dipole).



**Figure 14.16** The forces on each segment of a current-carrying rectangular loop of wire combine to produce a torque that tends to rotate the coil until its plane is perpendicular to the external magnetic field.

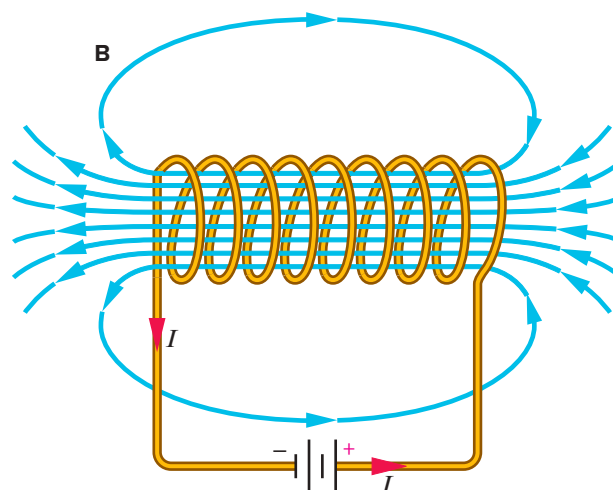


**Figure 14.17** A simple ammeter consists of a coil of wire, a permanent magnet, and a restoring spring to return the needle to zero when there is no current flowing through the coil.

### How do we make an electromagnet?

We have been discussing single loops of current as well as coils made of several loops all in the same direction. When there are several loops, is the produced magnetic field stronger? What effect do we get by winding a coil of wire on an iron or steel core?

We can readily conclude that the magnetic field produced by a coil of wire will be stronger than one produced by a



**Figure 14.18** A current-carrying coil of wire produces a magnetic field greater than that of a single loop and is proportional in strength to the number of loops in the coil.

single loop carrying the same current. The magnetic fields produced by each loop are all in the same direction near the axis of the coil, and thus they add. The resulting field strength is proportional to the number of turns  $N$  that are wound on the coil (fig. 14.18). The torque on the coil, when placed in an external field, is also proportional to both the current and the number of turns in the coil.

The effectiveness of a coil of wire as a magnet was discovered by French scientist Dominique-François Arago (1786–1853) soon after Oersted’s discovery. Arago first noticed that iron filings are attracted to a current-carrying copper wire much as they are to a magnet. Following a suggestion by Ampère, he found that the effect is enhanced if the wire is wound into the shape of a helix or coil. An even larger effect is obtained, however, if the coil is wound around a steel needle or nail. The ability to attract iron filings, in this case, is better than that of most natural magnets.

Arago showed that his simple **electromagnet** had a north pole and a south pole like those of a bar magnet. In fact, the magnetic field of a bar magnet is identical to one produced by an electromagnet of the same length and strength. This similarity led Ampère to suggest that the source of the magnetism in a naturally magnetic material like magnetite is current loops in the atoms that make up the material. If, for some reason, these atomic current loops all line up with one another and lock into those positions, a permanent magnet results.

In Ampère’s day, nothing was known about the structure of atoms. Atomic structure was not understood until the beginning of the twentieth century, almost a hundred years later. Even so, Ampère’s theory is remarkably close to our modern view of what happens in ferromagnetic metals such as iron, nickel, and cobalt and their alloys. We now know that the current loops are associated with the spins of the electrons in the atoms. Only in the latter half of the twentieth century did we come to understand why these spins tend to stay aligned in ferromagnetic materials but not in other materials.

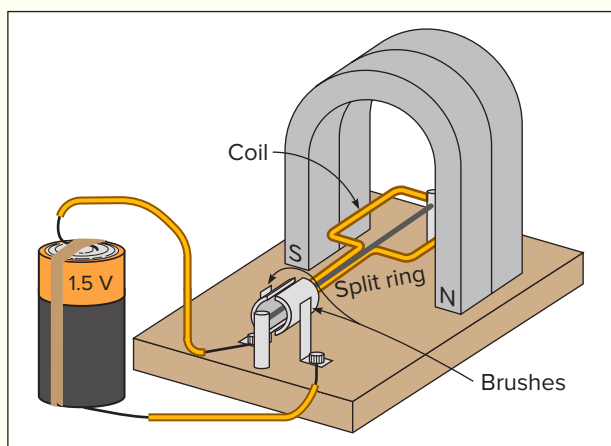
## Everyday Phenomenon

## Box 14.1

## Direct-Current Motors

**The Situation.** As a child, you may have built a simple direct-current motor that ran on flashlight batteries. Inexpensive kits are available, and building motors is a common science activity in the middle grades. How does a direct-current motor work? How can we keep the rotor moving in the same direction without using an alternating-current power source? How can we vary the speed of the motor?

**The Analysis.** There are many ways to build a dc motor, but the simplest ones usually take the form illustrated in the drawing. A coil of wire is wound on a rotor mounted so that it can rotate between the pole faces of a permanent horseshoe magnet. The coil is connected to a battery by sliding contacts (called brushes) that come up on either side of a split ring mounted on the axle of the rotor.



A simple dc motor consists of a wire-wound rotor mounted on an axle between the pole faces of a permanent magnet. The split ring causes the current to reverse directions every half turn.

Viewing the rotor as an electromagnet is a straightforward way to understand how the motor works. The south pole of the rotor is attracted to the north pole of the horseshoe magnet, causing the rotor to turn. When the rotor reaches the position where these two poles are closest, the current through the rotor is reversed. The contacts from the battery cross the gap between the two half-rings of the split ring attached to the coil, so that opposite ends of the coil are now connected to the positive and negative terminals of the battery.

This reversal in current makes the polarity of the electromagnet reverse. What had been the south pole becomes the

north pole and vice versa. As its momentum carries the rotor past the vertical position, its newly created north pole will now be attracted to the south pole of the horseshoe magnet, causing the rotor to continue to turn in the same direction that it had been moving. The torque on the rotor comes from the attraction of opposite poles of the two magnets, the rotor electromagnet and the permanent horseshoe magnet. Every half turn, the poles of the electromagnet flip due to the effect of the split-ring contacts.

This split-ring arrangement is a crucial feature of direct-current motors and is called a *split-ring commutator*. It consists of two half-circle metal bands, each connected to one end of the coil, mounted on an insulating cylinder. The metal half-rings make sliding contact with fixed-position metal strips, or *brushes*, on either side of the cylinder. An alternating-current motor does not need a split-ring commutator, because the current reverses direction every half-cycle.

Although we have viewed the rotor as an electromagnet, we could also view the torque on the rotor as a result of the magnetic forces on current elements on either side of the coil (see fig. 14.16). When the current in the coil reverses direction, these forces also reverse direction, so that the torque can be maintained in the appropriate direction.

The speed of a dc motor is related to the applied voltage, a convenience in situations where a variable-speed motor is needed. At first glance, this voltage dependence might not seem surprising, but its explanation actually follows from Faraday's law (section 14.4) rather than Ohm's law. If you compare our description of a motor to the description of the generator in section 14.5, you may be struck by the similarity of these two devices. In fact, we could use a motor as a generator if we supplied mechanical energy from an external source to turn the rotor. This happens when a hybrid car is braking, as described in everyday phenomenon box 11.1.

Because a motor behaves like a generator, there is a "back" voltage induced in the coil of the rotor due to Faraday's law and the changing magnetic flux through the coil. The magnitude of this induced voltage increases as the rotational velocity of the coil increases, just as in a generator. A larger voltage from the power source is required to overcome the larger back voltage induced as the rotational velocity of the rotor increases. To reach higher speeds, therefore, the applied voltage must be increased. An alternating-current motor usually runs at a fixed speed, but the speed of a direct-current motor can be continuously varied if we vary the voltage of the power supplied to the motor.

Within 10 years of Oersted's initial discovery of the magnetic effect of an electric current in 1820, many of the phenomena of electromagnetism had been thoroughly explored and described. Ampère was the leader in much of this work, and he was also responsible for developing the mathematical theory relating the magnetic forces on current-carrying wires and coils. His theory relating the magnetism in natural magnets to atomic current loops completed the link between electricity and magnetism. Magnetic effects can all be regarded as the action of electric currents—or moving charges.

The magnetic field of a single loop of wire carrying an electric current is identical to one of a short bar magnet or magnetic dipole. Like a bar magnet, a current loop also experiences a torque when placed in an externally produced magnetic field. This torque is the basis of operation of simple electric meters and electric motors. The effect is enhanced if we wind the wire into a coil and is greater still if we place an iron core in the center of the coil. A coil wound around an iron core becomes an electromagnet if we run a current through the coil. Natural magnets can be thought of as consisting of self-aligned current loops associated with the spins of electrons in the atoms of the magnetic material.

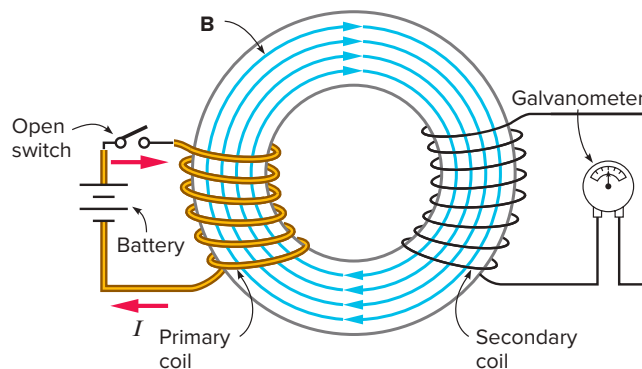
## 14.4 Faraday's Law: Electromagnetic Induction

The work of Oersted, Ampère, and others firmly established that magnetic forces are associated with electric currents. Using the field concept introduced by Maxwell, we now say that an electric current produces a magnetic field. What about the reverse? Can magnetic fields produce an electric current?

English scientist Michael Faraday got his start in science as an assistant to English chemist Sir Humphry Davy. Davy's primary interest, and much of Faraday's early work, was in the chemical action of electric currents, or electrolysis. Later, Faraday began a series of experiments to explore the possibility of producing an electric current from magnetic effects.

### What did Faraday's experiments show?

Faraday was aware that the magnetic effects of electric current are enhanced by coils, so he started his experiments by winding two unconnected coils of wire on the same wooden cylinder. One coil was connected to a battery and the other coil to a galvanometer. (A galvanometer measures both the direction and the size of an electric current.) Faraday wanted to see whether he could detect a current in the coil connected to the galvanometer when a current was flowing in the other coil connected to the battery.



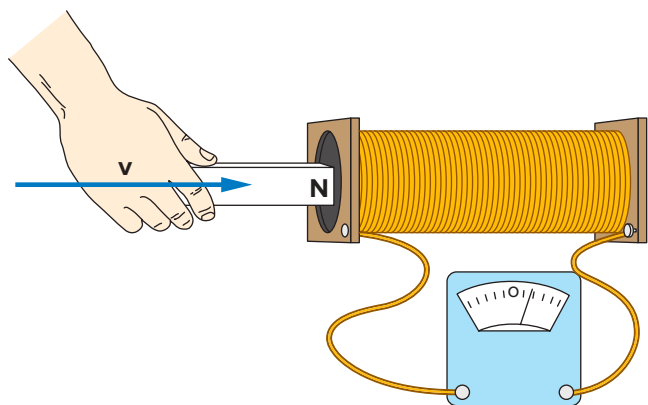
**Figure 14.19** Once the switch is closed, the current will travel in the direction shown, producing the magnetic field  $B$ . The galvanometer will read zero for a steady direct current.

The results of these first experiments were negative: No current was detected in the second coil. Undeterred, Faraday persisted by winding longer and longer coils. Finally, with coils of about 200 feet of copper wire, he noticed an effect. There was still no evidence of a steady current in the second coil, but there was a very brief and feeble deflection of the galvanometer needle when he connected the first coil to the battery. There was another momentary deflection in the opposite direction when he broke contact with the battery.

Faraday had not expected this effect, but experimentalists cannot be choosy about results. Through further experiments, Faraday found that he could get a considerably stronger deflection (although still momentary) if he wound both coils on an iron core (fig. 14.19) rather than on a wooden cylinder. Faraday wound two coils on either side of a welded iron ring. One coil, the *primary*, was connected to a battery; the other, the *secondary*, to his galvanometer. Again, the galvanometer needle deflected briefly in one direction when the primary circuit was closed and briefly in the opposite direction when the switch was opened.

No current was detected in the secondary coil when there was a steady current in the primary coil. Only if this primary current was *changing* as the circuit was completed or broken was a deflection noted. The strength of the deflection was proportional to the number of turns of wire wound on the secondary coil and to the strength of the battery used with the primary coil. Faraday began to formulate the idea that an electric current could be induced by magnetic effects that change with time, rather than by the steady-state presence of a magnet or electric current.

Faraday pursued this idea with many other experiments. One of these involved moving a permanent bar magnet in and out of a hollow helical coil of wire attached to a galvanometer (fig. 14.20). When the magnet moved in, the galvanometer needle deflected in one direction. When the magnet moved out, the needle deflected in the opposite direction. When the magnet was not moving, no deflection resulted. This is an easy effect to demonstrate with equipment available in most physics labs.



**Figure 14.20** A magnet moved in or out of a helical coil of wire produces an electric current in the coil.

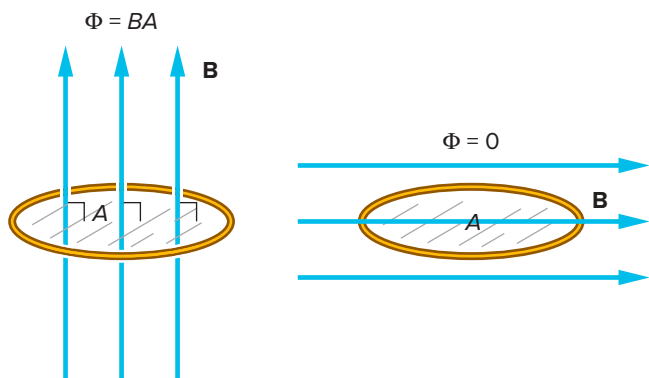
### Faraday's law

The results of all of Faraday's experiments indicate that an electric current is induced in a coil or circuit when the magnetic field passing through that circuit is changing. Because the amount of current flowing in the secondary circuit depends on the resistance of that circuit, we generally express these results in terms of the induced voltage rather than the current. To construct a quantitative statement to describe this effect, however, we need to define how much of the magnetic field passes through the circuit. This latter problem was solved by introducing the concept of **magnetic flux**. For a simple loop of wire lying in a plane perpendicular to the magnetic field, the magnetic flux is the product of the magnetic field  $B$  and the area  $A$  bounded by the loop (fig. 14.21). In symbols, the flux definition takes the form

$$\Phi = BA$$

The Greek letter  $\Phi$  (capital phi) is the standard symbol used for flux.

We must place an important qualification on this definition. Maximum flux is obtained when the field lines pass



**Figure 14.21** The magnetic flux through the loop of wire has its maximum value when the field lines are perpendicular to the plane of the loop. It is zero when the field lines are parallel to the plane of the loop and do not cross the plane.

through the circuit in a direction perpendicular to the plane of the circuit. If the field lines are parallel to this plane, there is no flux, because the field lines do not pass through the circuit (fig. 14.21). To take this fact into account, we use only the component of  $B$  that is perpendicular to the plane of the loop to calculate the flux.

We can now make a quantitative statement of **Faraday's law** that summarizes the results of his experiments:

A voltage (electromotive force) is induced in a circuit when there is a changing magnetic flux passing through the circuit. The induced voltage is equal to the rate of change of the magnetic flux. In symbols, this is

$$\mathcal{E} = \frac{\Delta\Phi}{t}$$

The rate of change of flux is found by dividing the change in flux  $\Delta\Phi$  by the time  $t$  required to produce this change. The process of inducing a voltage as described in Faraday's law is called **electromagnetic induction**.

The more rapidly the magnetic flux through the circuit changes, the larger the induced voltage, which can be readily observed in the experiment involving the moving magnet. If we move the magnet in and out of the coil quickly, we get larger deflections of the galvanometer needle than if we move it more slowly. The magnetic flux passing through a coil of wire runs through each loop in the coil, so the total flux through a coil is equal to the number of turns of wire in the coil times the flux through each turn, or  $\Phi = NBA$ . (Think about professional basketball to remember this expression.) The more turns of wire in the coil, the larger the induced voltage.

A coil of wire can be used to assess the strength of a magnetic field. The magnetic flux through the coil can be quickly reduced to zero either by removing the coil from the field or by giving it a quarter turn so that the field lines lie parallel to the plane of the coil. If we know the time required to make this change, we can find the strength of the magnetic field by measuring the induced voltage. The application of Faraday's law in example box 14.2 reverses this procedure by predicting the induced voltage from a known magnetic field.

### Lenz's law

Can we predict the direction of the induced current in the coil? The rule for doing so, **Lenz's law**, goes hand in hand with Faraday's law and is credited to Heinrich Lenz (1804–1865):

The direction of the induced current generated by a changing magnetic flux produces a magnetic field that opposes the *change* in the original magnetic flux.

If the magnetic flux decreases with time, the magnetic field produced by the induced current will be in the same

## Example Box 14.2

### Sample Exercise: How Much Voltage Is Induced?

A coil of wire with 50 turns has a uniform magnetic field of 0.4 T passing through the coil perpendicular to its plane. The coil encloses an area of 0.03 m<sup>2</sup>. If the flux through the coil is reduced to zero by removing it from the field in a time of 0.25 second, what is the induced voltage in the coil?

$$\begin{array}{ll} N = 50 \text{ turns} & \text{The initial flux through the coil is} \\ B = 0.4 \text{ T} & \Phi = NBA \\ A = 0.03 \text{ m}^2 & = (50)(0.40 \text{ T})(0.03 \text{ m}^2) \\ t = 0.25 \text{ s} & = 0.60 \text{ T} \cdot \text{m}^2 \end{array}$$

The induced voltage is equal to the rate of change of flux:

$$\begin{aligned} \mathcal{E} &= \frac{\Delta\Phi}{t} \\ &= \frac{(0.60 \text{ T} \cdot \text{m}^2 - 0)}{(0.25 \text{ s})} \\ &= 2.4 \text{ V} \end{aligned}$$

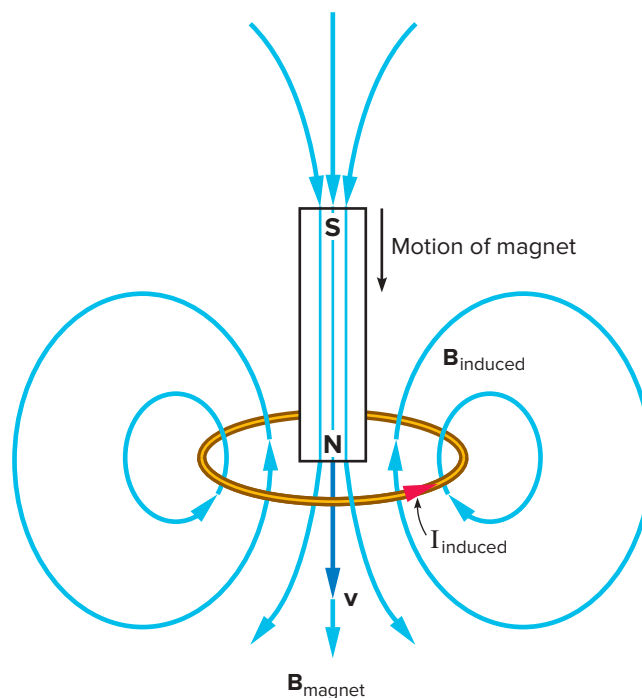
direction as the original external field, thus opposing the decrease. On the other hand, if the magnetic flux increases with time, the magnetic field produced by the induced current will be in the opposite direction to the original external field, thus opposing the increase.

Lenz's law is illustrated in figure 14.22. When the magnet moves into the coil and the flux increases with time, the induced current is in a counterclockwise direction in the coil. The magnetic field produced by this induced current is upward through the area bounded by the coil, thus opposing the increase in the downward field associated with the moving magnet. Lenz's law also explains why the galvanometer needle deflected in opposite directions when Faraday closed or opened the primary circuit in his experiments.

### What is self-induction?

Faraday first reported the results of his discoveries on electromagnetic induction in 1831. One year later, the discovery of a related effect was reported by Joseph Henry (1797–1878), who was working at Princeton University in the United States. Henry was experimenting with electromagnets when he noticed that the spark or shock obtained when an electromagnet was connected to a battery was larger than one obtained by touching the terminals of the battery with an uncoiled wire. The biggest sparks were obtained when the circuit was broken.

Henry explored this phenomenon in more detail. He found that a long wire yields a larger spark than a short wire and that coiling the wire into a helix yields an even larger spark. If the wire is wound on a steel nail to make an electromagnet, the effect is larger still. He roughly calibrated



**Figure 14.22** The induced current in the loop of wire produces an upward magnetic field inside the loop that opposes the increase in the downward field associated with the moving magnet.

the strength of the shock by noting how far up his arms it could be felt. If it could be felt just at the fingers, it was not very strong—one that could be felt at the elbows was obviously stronger. You can get a much stronger shock when you connect the wires of an electromagnet to a battery than when you touch the terminals of the battery directly with your fingers.

Henry had discovered **self-induction**. The changing magnetic flux through a coil of wire produced when the coil is connected or disconnected from the battery produces an induced voltage in the same coil. The induced current in the coil and its associated magnetic field oppose the changing magnetic flux. The magnitude of the induced voltage is described by Faraday's law and is proportional to the number of turns in the coil and to the rate of change of current in the coil. The voltage induced when the circuit is broken can be several times larger than the voltage of the battery itself.

Self-induction has many applications. Coils of wire are used in circuits to smooth out changes in current. The voltage induced when the current is increasing causes the change to take place more slowly than it would without the coil. This induced *back voltage* opposes the voltage difference that is producing the increase in current. An *inductor* or coil effectively adds electrical inertia to the system, which reduces rapid changes in current. (See everyday phenomenon box 14.2 for an application of this effect.) Induction coils are also used to generate large voltage pulses, such as those needed to power the spark plugs in an automobile.

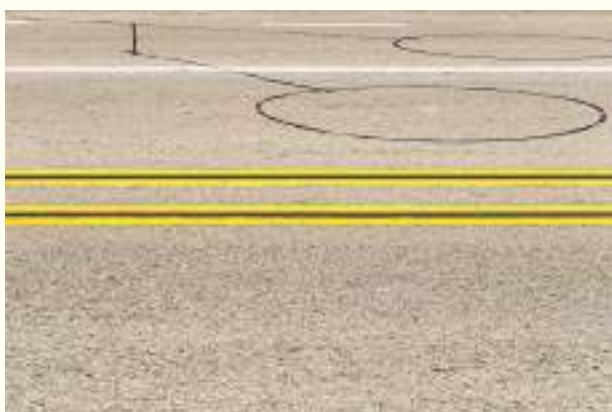
## Everyday Phenomenon

## Box 14.2

## Vehicle Sensors at Traffic Lights

**The Situation.** When you approach a traffic light in your car, you probably often notice a circular or diamond-shaped line in the pavement, as shown in the photograph. You may be aware that this pattern in the pavement has something to do with causing the traffic light to change. If your car is not positioned over this pattern, the light may not change.

How does this detector work? What lies underneath the pattern in the pavement? Why are these patterns becoming more and more common in traffic-control applications?

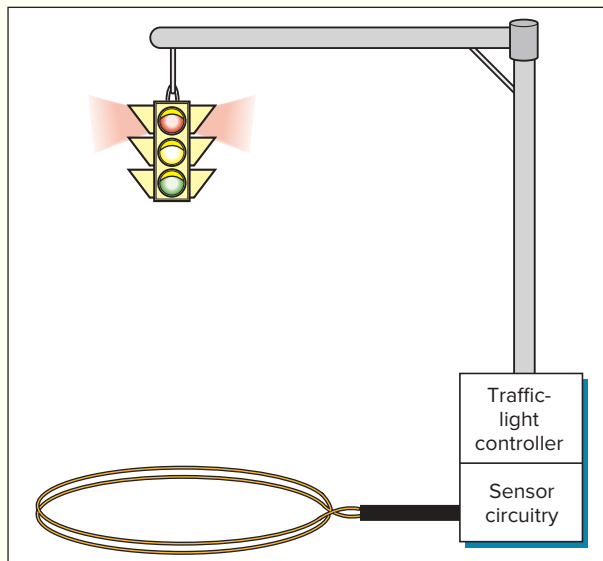


The circular pattern in the pavement indicates the presence of a vehicle sensor. How does this sensor work? Leah613/Getty Images

**The Analysis.** The pattern in the pavement conceals a large loop of wire with multiple turns. This loop or coil is an inductor. It is usually placed in the pavement after the paving is completed. A saw is used to cut a circular or diamond-shaped groove in the pavement, and the coil is laid in this groove. A rubberlike sealing compound is then used to cover the wire loop.

The wire-loop inductor is part of a circuit. The rest of this circuit is usually located somewhere on the side of the road. You may see a line in the pavement that contains wires leading to this circuit, or they may have been put in place before the paving was completed. The circuit containing the inductor is connected to the timing controls for the traffic light, as shown in the diagram.

How is this wire loop involved in detecting the presence of your car? When your car is located over the loop, the steel in the frame of your car increases the magnetic field being produced by the current in the coil. The effect is similar to that of placing a piece of iron inside the coil of an electromagnet. The presence of the iron strengthens the magnetic field, thus increasing the inductance of the coil. Iron is a component of steel, which is used extensively in the frames of automobiles and trucks. Any metal will have some effect on the inductance, though, due to its ability to conduct an induced current.



The wire loop in the pavement is part of a sensor circuit that sends a signal to the traffic-light timing controls.

Because the wire loop is part of an electric circuit, the change in inductance will affect the behavior of the circuit. There are many circuit designs that could be used to convert this change in inductance to a signal that controls the traffic light. For example, the inductor could be part of an oscillating circuit whose frequency depended on the value of the inductance. This change in frequency could be used to signal other circuitry that a vehicle was present.

Depending on how the controls for the traffic light are programmed, the signal indicating the presence of a vehicle will cause the light to change, perhaps after a short delay. Additional detectors farther back from the intersection can indicate how many vehicles are present. This information can be used to determine how long the light should remain green for a turn lane or side road.

These inductive detectors have become very common for managing the flow of traffic. If traffic is heavy in all directions at all times, then a simple timer system is used to control the traffic lights. If the traffic patterns vary with time of day and other factors, then the detectors can be used to optimize the timing of the lights to the current traffic conditions. If there is no traffic on a side road, for example, there is no point in stopping the traffic on a more major street or highway. If we can increase the efficiency of traffic flow using such techniques, we can save energy, reduce driver frustration, and decrease the need for more expensive highway-building solutions.

Michael Faraday discovered that an electric current can be induced in a coil of wire when the magnetic field passing through that coil is changing. Faraday's law states that the induced voltage in the coil is equal to the rate of change of the magnetic flux through the coil. Magnetic flux is defined as the magnetic field times the area enclosed by the coil. Lenz's law says that the direction of the induced current generates a magnetic field that opposes the change in the original magnetic flux. Joseph Henry discovered the related effect of self-induction, in which a voltage is induced in the same coil that is producing the changing magnetic flux.

## 14.5 Generators and Transformers

Our everyday use of electric power is so commonplace that we do not usually think about where the energy comes from or how it is generated. We know it comes to us through overhead or underground wires and that it powers our appliances, lights our homes and offices, and sometimes heats or cools our homes. We may also be aware of the transformers visible on utility poles and in electric substations.

Electric generators and transformers both play crucial roles in the production and use of electric power. Both are based on Faraday's law of electromagnetic induction. How do they work, and what roles do they play in the power-distribution system?

### How does an electric generator work?

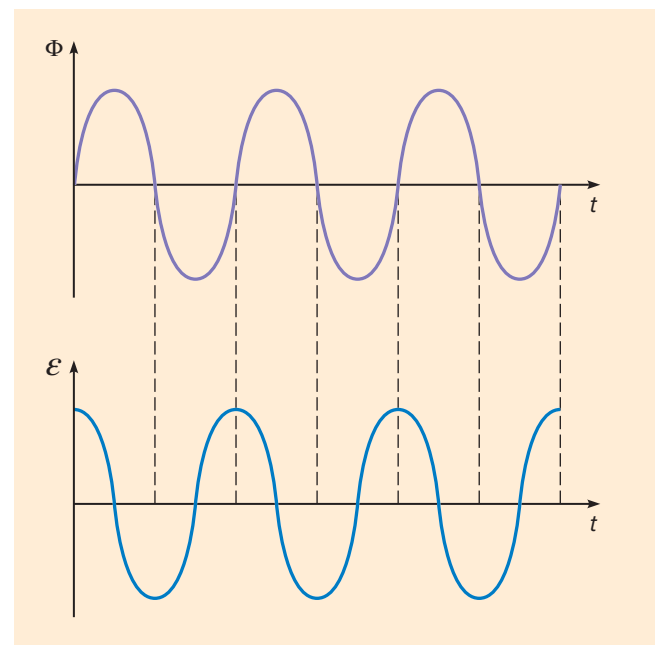
We mentioned the use of electric generators in our discussion of energy resources in chapter 11. The basic function of a **generator** is to convert mechanical energy, which might be obtained from a water turbine at a dam or a steam turbine in a power plant, to electrical energy. How is this done? How is Faraday's law involved in describing how a generator works?

A simple electric generator is shown in figure 14.23. Mechanical energy supplied by turning the crank rotates the coil of wire located between the pole faces of permanent magnets. The magnetic flux through the plane of the coil has its maximum value when this plane is perpendicular to the magnetic field lines passing between the poles of the magnets. As the coil is turned to a position where the plane of the coil is parallel to the field lines, the flux becomes zero. If we continue to turn the coil past this point, the field lines pass through the coil in the direction opposite to the initial direction (relative to the coil).

The coil's rotation causes the magnetic flux passing through the coil to change continuously from a maximum in one direction, to zero, to a maximum in the opposite direction, and so on, as shown in the upper graph of figure 14.24. By Faraday's law, a voltage is induced in the coil due to this



**Figure 14.23** A simple generator consists of a coil of wire that generates an electric current when turned between the pole faces of permanent magnets. *James Ballard/McGraw-Hill Education*



**Figure 14.24** Graphs of the magnetic flux  $\Phi$  and induced voltage  $\mathcal{E}$  for an electric generator, plotted on the same timescale.

changing magnetic flux. The magnitude of the induced voltage depends on the rate of change of the magnetic flux and on factors associated with the magnet and coil that determine the size of the maximum magnetic flux. The faster the coil is turned, the larger the maximum value of the induced voltage, because increased speed causes the magnetic flux to change more rapidly.

Figure 14.24 shows graphs of the continuously varying magnetic flux and the induced voltage plotted against time. If the axle of the coil is turned at a steady rate, we get a smooth variation of the flux, as in the top graph. Below the



flux graph, the graph of the induced voltage is plotted on the same timescale. By Faraday's law, induced voltage is equal to the rate of change of magnetic flux, so its maximum values occur where the slope of the flux curve is the greatest, and its zero values occur where the flux is momentarily not changing (zero slope). The resulting curve for the induced voltage has the same shape as for the flux but is shifted relative to the flux curve.

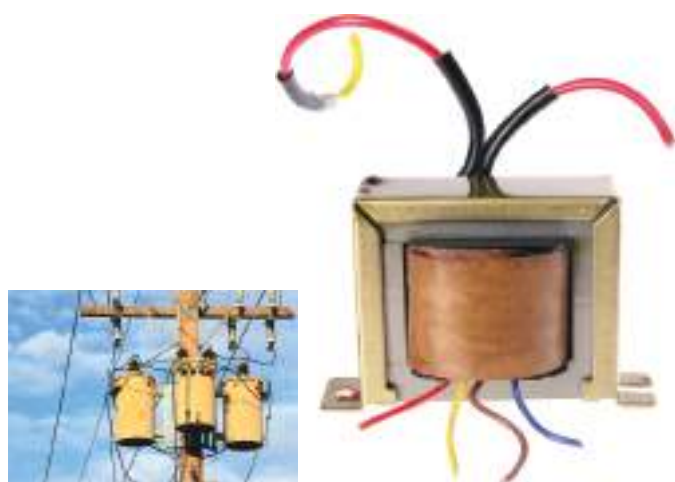
As the graphs show, the voltage that is normally produced by a generator is an *alternating* voltage: This is one reason that we use alternating current in our power-distribution system. For power production, the rotational velocity of the generator coils must be maintained at a specific value to produce the 60-Hz (60-cycles/s) alternating current that is the standard frequency in the United States.

The electric generators used in power plants resemble the simple one described here. Usually, they have more than one coil, and the magnets are electromagnets rather than permanent magnets, but the principle of operation is the same. There is also an electric generator in a car—the electric power generated keeps the battery charged, operates the lights, and powers other electrical systems.

### What does a transformer do?

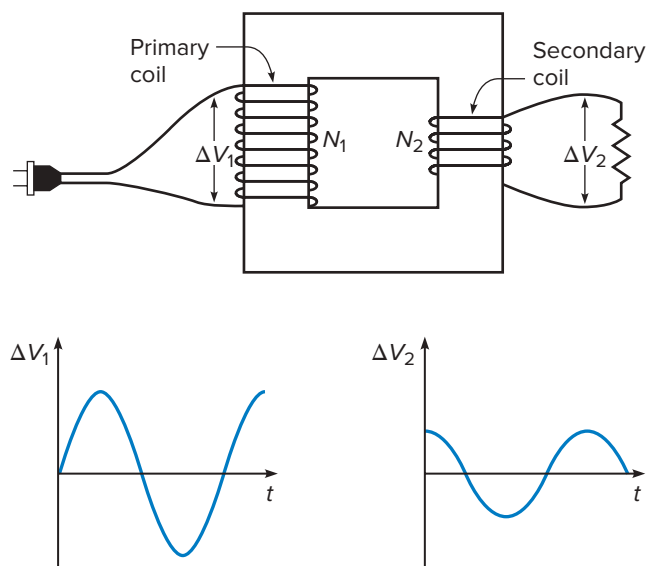
Another advantage of alternating current in power distribution is that **transformers** can change the voltage. Transformers are familiar sights. You see them on utility poles, at electrical substations, and as voltage adapters for low-voltage devices such as model electric trains (fig. 14.25). Their function is to adjust the voltage up or down to suit the needs of a particular application.

Some of Faraday's early experiments involved prototypes of the modern transformer. His apparatus with primary and secondary coils wound on either side of an iron ring (fig. 14.19) is



**Figure 14.25** Transformers on utility poles and at electrical substations are familiar sights. Smaller ones are common components of electrical devices.

(left): montreehanlue/123RF; (right): homestudio/123RF



**Figure 14.26** An alternating voltage applied to the primary coil of a transformer  $\Delta V_1$  produces a changing magnetic flux, which induces a voltage in the secondary coil  $\Delta V_2$ .

an example of a simple transformer. By Faraday's law, a voltage will be induced in the secondary coil if the current (and the associated magnetic field) of the primary coil is changing. This condition is present if we power the primary coil with an alternating-current source (fig. 14.26).

What determines the size of the change in voltage that a transformer can produce? A simple relationship follows from Faraday's law. The voltage induced on the secondary coil is proportional to the number of turns on the secondary coil, because the number of turns determines the total magnetic flux passing through this coil. The induced voltage is also proportional to the voltage on the primary coil, because this determines the size of the primary current and its associated magnetic field. The induced voltage is inversely proportional, however, to the number of turns on the primary coil.

Stated in symbols, this relationship takes the form

$$\Delta V_2 = \Delta V_1 \left( \frac{N_2}{N_1} \right)$$

where  $N_1$  and  $N_2$  are the number of turns of wire on the primary and secondary coils, and  $\Delta V_1$  and  $\Delta V_2$  are the associated voltages. This relationship is often written as the proportion

$$\frac{\Delta V_2}{\Delta V_1} = \frac{N_2}{N_1}$$

The ratio of the number of turns on the two coils determines the ratio of the voltages.

Self-induction is the reason that the voltage induced on the secondary coil is inversely proportional to the number of turns on the primary coil. The more turns on the primary coil, the harder it is to produce a rapid change in current in the primary coil because of the back voltage

produced by self-induction. This effect limits the current and the size of the magnetic field produced by the primary coil, which limits the magnetic flux passing through the secondary coil.

Suppose you want to run an electric train at 12 volts, but the electric power provided at the wall socket is 120 volts. You need a transformer with 10 times as many turns on the primary coil as on the secondary coil, which yields a voltage in the secondary coil one-tenth of the primary coil, or 12 volts. (See example box 14.3.)

If the output voltage is higher than the input voltage, are we somehow getting more power out of the transformer than what we put in? The answer, of course, is no. The power delivered to the secondary circuit is always less than, or at best equal to, the power provided to the primary coil. Because electric power can be expressed as the product of the voltage times the current (see section 13.4), conservation of energy provides a second relationship useful for analyzing transformers:

$$\Delta V_2 I_2 \leq \Delta V_1 I_1$$

A high-output voltage is associated with a low-output current. The output power does not exceed the input power. If we are stepping down to a smaller voltage in the secondary circuit, the secondary current can be larger than what was provided to the primary coil, but the power cannot exceed that provided to the primary coil.

### Transformers and power distribution

High voltages are desirable for long-distance transmission of electric power. The higher the voltage, the lower the current

for a given amount of power transmitted. Because the heat losses caused when current flows through a resistance are related most directly to the current ( $P = I^2R$ ), smaller currents mean less energy lost to resistive heating in the transmission wires. Transmission voltages as high as 230 kV (230 kilovolts, or 230 000 volts) are not unusual.

Such high voltages are not safe or convenient for power distribution in a city or for use in homes or buildings. Transformers at electrical substations reduce the voltage to 7200 volts for distribution in town. Transformers on utility poles or those partially underground lower this voltage further to 220 to 240 volts for entry into buildings. This ac voltage can be split inside the building to yield the 110 volts commonly used for household circuits while keeping 220 volts available for stoves, dryers, and electric heating.

The original electrical distribution system in the United States was a 110-volt direct-current system designed in 1882 by Thomas Edison for a portion of New York City. There was controversy for several years afterward about whether direct-current or alternating-current systems were the most appropriate for the delivery of electric power. In the end, the proponents of the ac system prevailed. The abilities to transmit electric power at high voltages and to use transformers to step these voltages down at the point of use were major reasons for this choice.

Direct current is occasionally used to transmit power over large distances, because it does not lose energy by radiation of electromagnetic waves. Radiation is a drawback of alternating current. The power line acts as an antenna that radiates electromagnetic waves when the current is oscillating (see section 16.1).

A transformer works best with alternating current. Faraday's law requires that magnetic flux *change* for there to be an induced voltage. If we tried to use a transformer with a battery or other dc source, we would have to continually make and break the primary circuit somehow to induce a voltage in the secondary circuit. There are means of accomplishing this, but they add to the complexity and cost of a system and are less efficient than using alternating current.

### Example Box 14.3

#### Sample Exercise: A Step-Up Transformer

A transformer connected to a 120-V ac line is to supply 9600 V for a neon sign.

- What is the ratio of secondary to primary turns of the transformer?
- If the transformer consisted of 275 primary windings, how many secondary windings would there be?

$$\begin{aligned} \text{a. } \Delta V_1 &= 120 \text{ V} & \frac{\Delta V_2}{\Delta V_1} &= \frac{N_2}{N_1} = \frac{9600 \text{ V}}{120 \text{ V}} = 80 \\ \Delta V_2 &= 9600 \text{ V} & & \\ \frac{N_2}{N_1} &= ? & \text{The ratio of secondary to} & \\ & & \text{primary turns would be 80.} & \end{aligned}$$

$$\begin{aligned} \text{b. } N_1 &= 275 & \text{if } \frac{N_2}{N_1} &= 80 \text{ then } N_2 = 80 \times N_1 \\ N_2 &= ? & N_2 &= 80 \times 275 = 22,000 \end{aligned}$$

Electric generators convert mechanical energy to electrical energy by rotating a coil through a magnetic field, thus inducing a voltage due to the changing magnetic flux. Transformers adjust voltages up or down by passing a changing magnetic field produced by an alternating current in a primary coil, which then passes through a secondary coil. By Faraday's law, this induces a voltage in the secondary coil. The operation of generators and transformers is based on Faraday's law, and both play major roles in power-distribution systems.

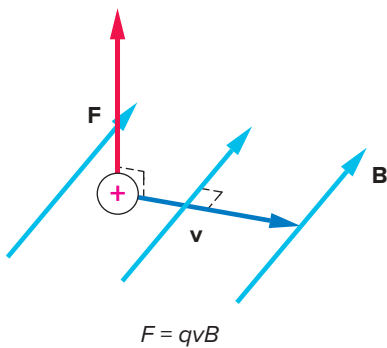
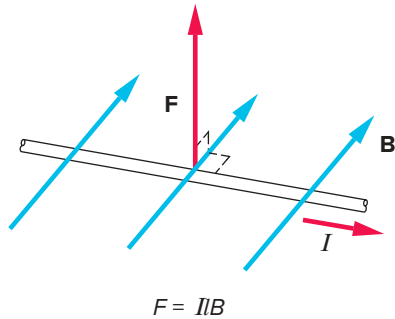
## Summary

The discovery that magnetic forces are associated with electric currents unified the study of electricity and magnetism in the early part of the nineteenth century. The fundamental nature of magnetism was shown to be due to the motion of electric charges. Electric currents can be produced by changing magnetic fields, as described by Faraday's law.

**1 Magnets and the magnetic force.** Like electrostatic forces, the magnetic force between the poles of two magnets obeys Coulomb's law and the rule that like poles repel and unlike poles attract. The Earth itself behaves like a large magnet, with its South Pole pointing northward.

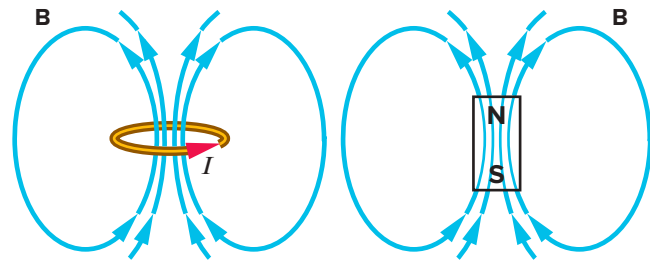


**2 Magnetic effects of electric currents.** Oersted's discovery that magnetic effects are associated with electric currents led to the description of the magnetic field of a current-carrying wire. A magnetic force is exerted on either a current-carrying wire or a moving charge when they are located in a magnetic field.

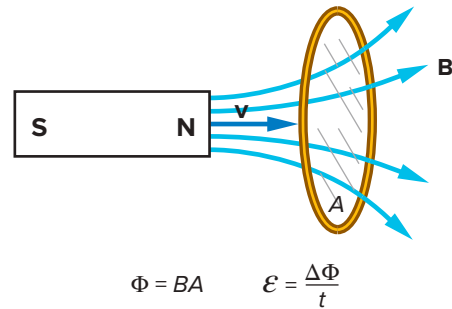


**3 Magnetic effects of current loops.** A current-carrying loop of wire produces a magnetic field identical to the field of a short bar magnet. Current loops and coils are magnetic dipoles, and

the magnetism of natural magnets can be attributed to atomic current loops. A magnetic torque exerted on a current loop in an external field is similar to that exerted on a bar magnet.



**4 Faraday's law: Electromagnetic induction.** Faraday discovered that a voltage is induced in a circuit equal to the rate of change of magnetic flux passing through the circuit (Faraday's law). Magnetic flux is equal to the product of the magnetic field and the area bounded by the circuit when the field lines are perpendicular to the plane of the loop. Lenz's law describes the direction of the induced current: The current opposes the change producing it.



**5 Generators and transformers.** A generator converts mechanical energy to electrical energy by electromagnetic induction and naturally produces an alternating current. Transformers are used to adjust alternating voltages up and down. Faraday's law is the basic principle of operation for both of these devices, and both are commonly used in our power-distribution system.

The interconnections between magnetic and electric properties often are surprising to people when they first discover them. Try the mastery quiz in Connect to increase your conceptual understanding and the study hints to give you an overview of these attractive concepts.

## Key Terms

Magnetic pole, 285  
 Magnetic dipole, 287  
 Magnetic monopole, 287  
 Magnetic force, 290  
 Magnetic field, 290

Electromagnet, 293  
 Magnetic flux, 296  
 Faraday's law, 296  
 Electromagnetic induction, 296  
 Lenz's law, 296

Self-induction, 297  
 Generator, 299  
 Transformer, 300

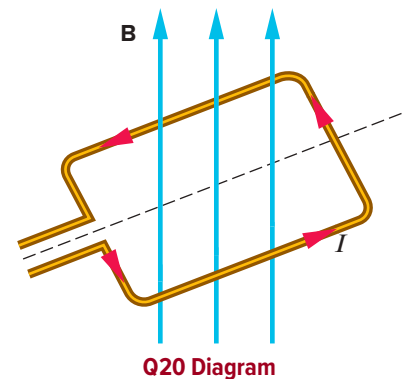
## Conceptual Questions

\* = more open-ended questions, requiring lengthier responses, suitable for group discussion

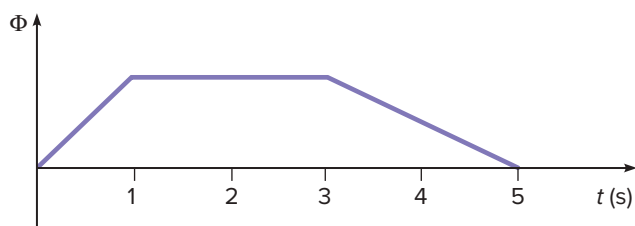
Q = sample responses are available in appendix D

Q = sample responses are available in Connect

- Q1. The north pole of a handheld bar magnet is brought near the north pole of a second bar magnet lying on a table. How will the second magnet tend to move? Explain.
- Q2. If the distance between the south poles of two long bar magnets is reduced to half its original value, will the force between these poles be doubled? Explain.
- Q3. In what respects is the force between two magnetic poles similar to the force between two charged particles? Explain.
- Q4. Is it possible for a bar magnet to have just one pole? Explain.
- Q5. Does a compass needle always point directly northward in the absence of other nearby magnets or currents? Explain.
- \*Q6. If we regard the Earth as a magnet, does its magnetic north pole coincide with its geographic north pole? What defines the position of the geographic north pole? Explain.
- Q7. We visualized the magnetic field of the Earth by imagining that there is a bar magnet inside the Earth (fig. 14.8). Why did we draw this magnet with its south pole pointing north? Explain.
- Q8. A horizontal wire is oriented along a north-south line, and a compass is placed above it. Will the needle of the compass deflect when a current flows through the wire, and if so, in what direction? Explain.
- Q9. A horizontal wire is oriented along an east-west line, and a compass is placed above it. Will the needle of the compass deflect when a current flows through the wire from east to west, and if so, in what direction? Explain.
- Q10. Is the force exerted by one current-carrying wire on another due to electrostatic effects or to magnetic effects? Explain.
- Q11. Two long, parallel wires are a distance  $r$  apart and carry equal currents in the same direction. If the distance between the wires triples, while the currents remain the same, what effect does this have on the attractive force per unit length felt by the wires?
- Q12. Two long, parallel wires are a distance  $r$  apart. The currents in the two wires are in the same direction, but they are not equal in magnitude. The current in wire 1 is four times the current in wire 2. Is the force of attraction that wire 1 feels due to wire 2 different from the force of attraction that wire 2 feels due to wire 1? Explain.
- Q13. Two long, parallel wires are a distance  $r$  apart and carry equal currents in opposite directions. If the current in wire 1 decreases by half, but the current in wire 2 stays the same, what effect does this have on the repulsive force per unit length felt between the wires?
- Q14. A uniform magnetic field is directed horizontally toward the north, and a positive charge is moving west through this field. Is there a magnetic force on this charge, and if so, in what direction? Explain.
- Q15. A positively charged particle is momentarily at rest in a uniform magnetic field. Is there a magnetic force acting on this particle? Explain.
- Q16. If a uniform magnetic field is directed horizontally toward the east, and a negative charge is moving east through this field, is there a magnetic force on this charge, and if so, in what direction? Explain.
- Q17. Why does the magnetic force on a current-carrying segment of wire behave like one on a positive charge traveling in the same direction as the current? Explain.
- Q18. If we look down at the top of a circular loop of wire whose plane is horizontal and that carries a current in the clockwise direction, what is the direction of the magnetic field at the center of the circle? Explain.
- Q19. If we were to represent the current loop of question 18 as a bar magnet or magnetic dipole, in what direction would the north pole be pointing? Explain.
- \*Q20. A current-carrying rectangular loop of wire is placed in an external magnetic field with the directions of the current and field, as shown in the diagram. In what direction will this loop tend to rotate as a result of the magnetic torque exerted on it? Explain.

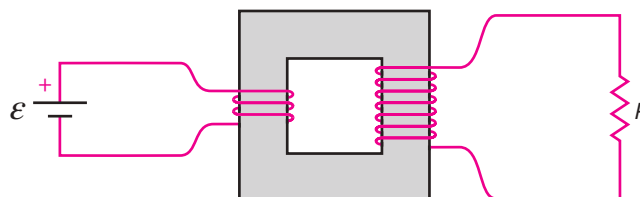


- \*Q21. If the rectangular loop of wire shown in question 20 were oriented so that the plane of the loop was parallel to the magnetic field lines, would there be a net torque acting on the loop? Explain.
- Q22. Because the magnetic fields of a coil of wire and a bar magnet are identical, are there loops of current inside natural magnetic materials such as iron or cobalt? Explain.
- Q23. In what respect is a simple ammeter designed to measure electric current like an electric motor? Explain.
- Q24. Does an ac motor require a split-ring commutator to work? Explain. (See everyday phenomenon box 14.1.)
- Q25. Which type of motor typically runs at a fixed speed, an alternating-current motor or a direct-current motor? Explain. (See everyday phenomenon box 14.1.)
- Q26. If Faraday wound enough turns of wire on the secondary coil of his iron ring, would he have found that a large steady-state current in the primary coil induced a current in the secondary coil? Explain.
- Q27. Is a magnetic flux the same as a magnetic field? Explain.
- \*Q28. A horizontal loop of wire has a magnetic field passing upward through the plane of the loop. If this magnetic field increases with time, is the direction of the induced current clockwise or counterclockwise (viewed from above), as predicted by Lenz's law? Explain.
- \*Q29. Suppose the magnetic flux through a coil of wire varies with time, as shown in the diagram. Using the same timescale, sketch a graph showing how the induced voltage varies with time. Where does the induced voltage have its largest magnitude? Explain.



Q29 Diagram

- Q30. Two coils of wire are identical, except that coil A has twice as many turns of wire as coil B. If a magnetic field increases with time at the same rate through both coils, which coil (if either) has the larger induced voltage? Explain.
- Q31. Do the sensors that detect vehicles at stoplights depend on the weight of a vehicle to trigger the change? Explain. (See everyday phenomenon box 14.2.)
- Q32. Under which conditions are inductive detectors more effective than simple timer systems—when the traffic is heavy in all directions at all times or when the traffic varies with time of day and other factors? Explain. (See everyday phenomenon box 14.2.)
- Q33. If the magnetic field produced by the magnets in a generator is constant, does the magnetic flux through the generator coil change when it is turning? Explain.
- Q34. Does a simple generator produce a steady direct current? Explain.
- Q35. A simple generator and a simple electric motor have very similar designs. Do they have the same function? Explain.
- Q36. Can a transformer be used, as shown in the diagram, to step up the voltage of a battery? Explain.



Q36 Diagram

- Q37. By stepping up the voltage of an alternating-current source using a transformer, can we increase the amount of electrical energy drawn from the source? Explain.

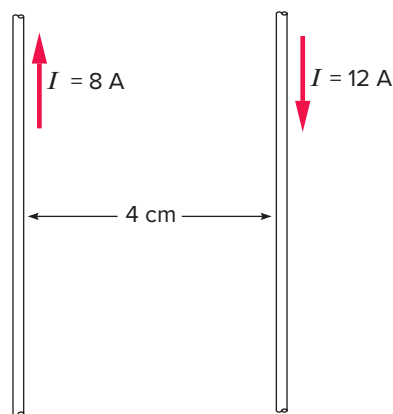
## Exercises

- E1. Two long bar magnets lying on a table with their south poles facing each other exert a force of 18 N on each other. If the distance between these two poles is tripled, what is the new value of this force?
- E2. Two long, parallel wires, each carrying a current of 12 A, lie a distance of 7 cm from each other. What is the magnetic force per unit length exerted by one wire on the other?
- E3. If the distance between the two wires in exercise 2 is doubled, how does the force per unit length change?
- E4. Two parallel wires, each carrying a current of 4 A, exert a force per unit length on each other of  $1.88 \times 10^{-5}$  N/m. What is the distance between the wires?
- E5. A wire carries a current of 12 A. How much charge flows past a point on the wire in a time of 4 s?
- E6. A particle with a charge of 0.6 C is moving at right angles to a uniform magnetic field with a strength of 0.5 T. The velocity of the charge is 800 m/s. What is the magnitude of the magnetic force exerted on the particle?
- E7. A straight segment of wire has a length of 12 cm and carries a current of 7 A. It is oriented at right angles to a magnetic field of 0.5 T. What is the magnitude of the magnetic force on this segment of wire?
- E8. The magnetic force on a 60-cm straight segment of wire carrying a current of 7 A is 2.0 N. What is the magnitude of the component of magnetic field perpendicular to the wire?

- E9. A coil of wire with 150 turns has a cross-sectional area of  $0.03 \text{ m}^2$ . A magnetic field of  $0.4 \text{ T}$  passes through the coil. What is the total magnetic flux passing through the coil?
- E10. A loop of wire enclosing an area of  $0.04 \text{ m}^2$  has a magnetic field passing through its plane at an angle to the plane. The component of the field perpendicular to the plane is  $0.12 \text{ T}$ , and the component parallel to the plane is  $0.05 \text{ T}$ . What is the magnetic flux through this coil?
- E11. The magnetic flux through a coil of wire changes from  $9 \text{ T} \cdot \text{m}^2$  to zero in a time of  $0.50 \text{ s}$ . What is the magnitude of the average voltage induced in the coil during this change?
- E12. A coil of wire with 120 turns and a cross-sectional area of  $0.03 \text{ m}^2$  lies with its plane perpendicular to a magnetic field of magnitude  $1.8 \text{ T}$ . The coil is rapidly removed from the magnetic field in a time of  $0.4 \text{ s}$ .
- What is the initial magnetic flux through the coil?
  - What is the average value of the voltage induced in the coil?
- E13. A transformer has 18 turns of wire in its primary coil and 90 turns on its secondary coil.
- Is this a step-up or step-down transformer?
  - If an alternating voltage with an effective voltage of  $120 \text{ V}$  is applied to the primary, what is the effective voltage induced in the secondary?
- E14. If  $15 \text{ A}$  of current are supplied to the primary coil of the transformer in exercise 13, what is the maximum effective current in the secondary coil?
- E15. A step-down transformer is to be used to convert an ac voltage of  $120 \text{ V}$  to  $12 \text{ V}$  to power an electric train. If there are 430 turns in the primary coil, how many turns should there be in the secondary coil?
- E16. A step-up transformer is designed to produce  $1840 \text{ V}$  from a  $115\text{-V}$  ac source. If there are 384 turns on the secondary coil, how many turns should be wound on the primary coil?

## Synthesis Problems

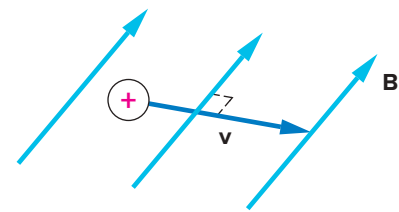
- SP1. Two long, parallel wires carry currents of  $8 \text{ A}$  and  $12 \text{ A}$  in opposite directions, as shown in the diagram. The distance between the wires is  $4 \text{ cm}$ .
- What is the magnitude of the force per unit length exerted by one wire on the other?
  - What are the directions of the forces on each wire?
  - What is the total force exerted on a  $30\text{-cm}$  length of the  $12\text{-A}$  wire?
  - From this force, compute the strength of the magnetic field produced by the  $8\text{-A}$  wire at the position of the  $12\text{-A}$  wire ( $F = IIB$ ).
  - What is the direction of the magnetic field produced by the  $8\text{-A}$  wire at the position of the  $12\text{-A}$  wire?



SP1 Diagram

- SP2. A small metal ball with a charge of  $+0.08 \text{ C}$  and a mass of  $25 \text{ g}$  ( $0.025 \text{ kg}$ ) enters a region where there is a magnetic field of  $0.5 \text{ T}$ . The ball is traveling with a velocity of  $110 \text{ m/s}$  in a direction perpendicular to the magnetic field, as shown in the diagram.
- What is the magnitude of the magnetic force acting on the ball?

- What is the direction of the magnetic force exerted on the ball when it is at the position shown?
- Will this force change the magnitude of the velocity of the ball? Explain.
- From Newton's second law, what is the magnitude of the acceleration of the charged ball?
- Because centripetal acceleration is equal to  $v^2/r$ , what is the radius of the curve the ball will move through under the influence of the magnetic force?



SP2 Diagram

- SP3. A rectangular coil of wire has dimensions of  $4 \text{ cm}$  by  $8 \text{ cm}$  and is wound with 70 turns of wire. It is turned between the pole faces of a horseshoe magnet that produces an approximately uniform field of  $0.5 \text{ T}$ , so that sometimes the plane of the coil is perpendicular to the field and sometimes it is parallel to the field.
- What is the area bounded by the rectangular coil?
  - What is the maximum value of the total magnetic flux that passes through the coil as it is turned?
  - What is the minimum value of the total flux through the coil as it turns?
  - If the coil makes one complete turn each second and turns at a uniform rate, what is the time involved in changing the flux from the maximum value to the minimum value?
  - What is the average value of the voltage generated in the coil as it passes from the maximum to the minimum value of flux?

- SP4. A transformer is designed to step down line voltage of 110 V to 6 V. The primary coil has 1155 turns of wire.
- How many turns of wire should there be on the secondary coil?
  - If the current in the primary coil is 2 A, what is the maximum possible current in the secondary coil?
  - If the transformer gets warm during operation, will the current in the secondary coil equal the value computed in part b? Explain.

## Home Experiments and Observations

- HE1. Look around your home or residence hall to see how many magnets you can find. Small packages of magnets can often be found in variety stores or hardware stores for hanging tools or other uses.
- If you have a bar magnet, find its north-seeking pole by suspending it from a string and seeing which end points north.
  - Use this magnet, or another one whose north and south poles can be identified, to find the poles of your other magnets and label them north or south with a crayon.
  - Verify that two like poles repel and two unlike poles attract for any combination of your available magnets.
  - Try to determine which of your various magnets is the strongest by seeing over what distance it will attract a paper clip or other small steel item. (The largest magnet may not be the strongest!)
- HE2. If you have a small compass, you can use it to explore the magnetic field of magnets and currents. The compass needle will always point in the direction of the net magnetic field, wherever it is located.
- Using the compass near a bar or horseshoe magnet, find out how far you must move the compass from the magnet before the field of the magnet is no longer noticeable and the compass needle simply points north.
  - Bringing the compass close to the magnet, determine the direction of the magnetic field at various points around the magnet. Make a sketch showing the direction of the field at selected points around the magnet.
- HE3. Using a long, insulated wire, wrap several turns (as many as 50 to 100) around a large steel nail. If the free ends of the wire are connected to a flashlight battery, you have an electromagnet. (To avoid depleting the battery, do not leave the wire connected to the battery very long.)
- Compare the strength of your electromagnet to some of the permanent magnets you may have available. (At what distance can each pick up a paper clip?)
  - Note whether you see a spark when you break the connection between the electromagnet and the battery. Do you get the same effect with an uncoiled length of wire?

# UNIT 4

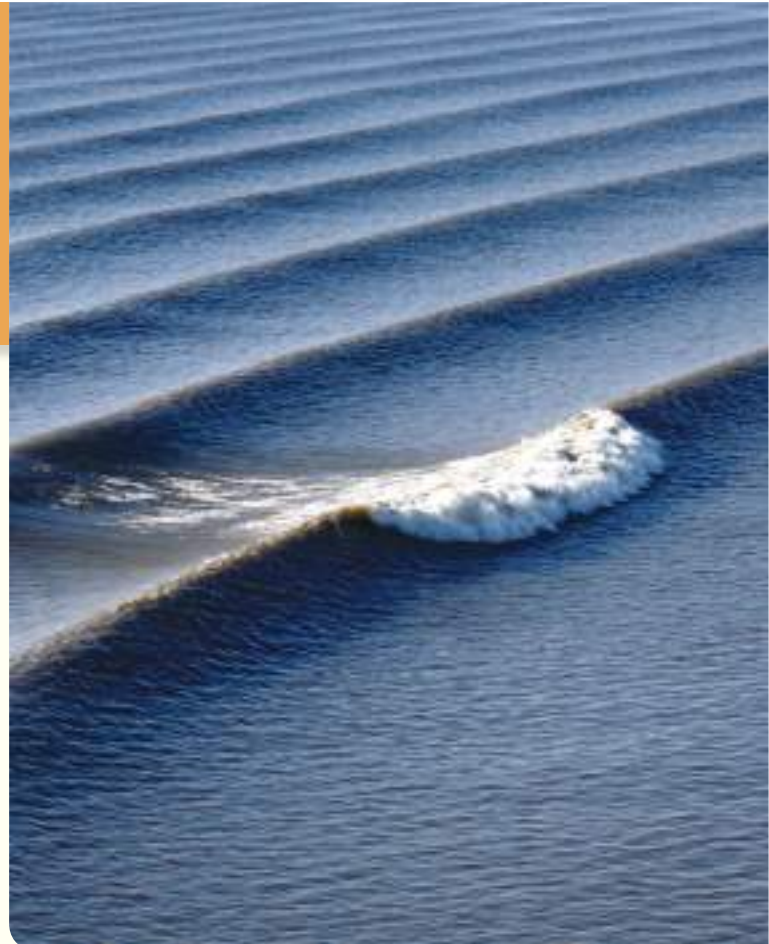
## Wave Motion and Optics

Isaac Newton is best known for his pioneering work in mechanics, but he also wrote a major treatise on optics. In this work, he explained many aspects of the behavior of light by assuming that light consisted of a stream of invisible particles. Reflection, refraction, and the splitting of light into its component colors by a prism could all be explained by this model.

A Dutch contemporary of Newton, Christian Huygens (1629–1695), held an opposing view. He assumed that light was a wave and he successfully explained the same phenomena treated by Newton. For the next one hundred years, these two views competed for acceptance, but because of Newton's prestige, the particle view was more widely held.

In 1800, a British physician, Thomas Young (1773–1829), performed his famous double-slit experiment, which demonstrated interference effects involving light. Interference is a wave phenomenon, so Young's experiment tipped the scales in favor of a wave model of light. During the next 50 years, physicists and mathematicians developed a detailed mathematical description of the behavior of waves and successfully explained many newly discovered features of light interference. In 1865, James Clerk Maxwell predicted the existence of electromagnetic waves having the same velocity as light. This suggested that light was an electromagnetic wave and reinforced the wave model of light by describing the nature of these waves.

Wave motion is now recognized as a universal feature of a wide range of phenomena. Sound waves, light



Kenna Love/Alamy Stock Photo

waves, waves on springs and ropes, water waves, seismic waves (involved in earthquakes), and gravitational waves are actively studied. The theory of quantum mechanics, developed in the twentieth century, even applies wave concepts to particles such as electrons. Reflection, refraction, and interference, which we explore in chapters 15, 16, and 17, are all characteristic of wave motion.

Ironically, developments in the twentieth century showed that light sometimes demonstrates particle-like behavior. We now view a light wave as consisting of a stream of *photons*, particles of light having some characteristics of waves. Although this concept differs from Newton's particle model, Newton may be partially vindicated by these more recent developments. Light (or any wave motion) can exhibit both wave and particle-like behavior, and conversely, any particle has wavelike features. Waves are everywhere—they have become a central theme in physics.





# CHAPTER 15

Science Photo Library/Getty Images

## Making Waves

---

### Chapter Overview

Our main objective in this chapter is to investigate the basic nature of waves and their properties. The properties of waves include speed, wavelength, period, and frequency and the phenomena of reflection, interference, and energy transmission. We examine a few types of wave motion in more detail, including waves on a string and sound waves. We also explore features of musical sound waves.

### Chapter Outline

- 1 Wave pulses and periodic waves.** How do wave pulses travel along a spring or rope? What distinguishes a longitudinal pulse from a transverse pulse? How are wave pulses related to longer periodic waves?
- 2 Waves on a rope.** What are the general features of a simple wave traveling on a rope? How are the wave's properties of frequency, period, wavelength, and speed related to one another? What factors influence the wave speed?
- 3 Interference and standing waves.** What happens when two or more waves combine? What do we mean by interference? What is a standing wave, and how is it produced?
- 4 Sound waves.** What are sound waves? How are they produced? How do the musical properties of pitch and harmonics relate to the wave properties of sound?
- 5 The physics of music.** How can we analyze the sound waves produced by musical instruments? Why are some combinations of frequencies harmonious and others dissonant?

If you have ever visited a beach at an ocean or large lake, you have probably delighted in the idle pastime of watching the waves come in. A cliff or some other high spot is a good vantage point for this amusement. From such a height, you can track a single wave crest as it moves in and finally breaks on the shore (fig. 15.1). Because of their regularity, watching waves can be relaxing, even hypnotic.

As you watched the waves, you may have been struck by a curious aspect of their behavior. Although the water seems to move toward the shore, no water accumulates on the beach. So what is happening—what is actually moving? Is this apparent motion of the water somehow deceiving us?

If you stand in the surf and let the waves break over you, you certainly get the sense that the waves are carrying energy. A big wave can knock you over or carry you along. A person on a surfboard can achieve a large velocity by riding the crest of a wave. The kinetic energy gained in this manner comes from the wave.

Although the behavior of water waves near the shore is complex, water waves exhibit many of the general features associated with wave motions of all types. Light, sound, radio waves, and waves on guitar strings are all examples



**Figure 15.1** The waves move in and break on the shore. Why does the water not accumulate there? *Bogdan Bratosin/Moment/Getty Images*

of wave motion that have much in common with the waves we observe at the beach. Wave motion has implications for all areas of physics, including atomic and nuclear physics. An enormous range of phenomena can be explained in terms of waves.

## 15.1 Wave Pulses and Periodic Waves

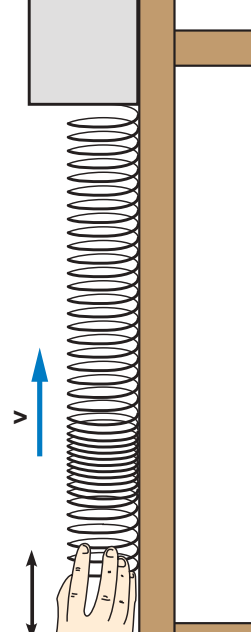
Although water waves have characteristics that are common to any wave motion, the details of their motion are often quite complex, particularly near a beach. That complexity adds to their beauty and allure, but for a beginning discussion of the nature of waves, we need a simpler example. A Slinky, that toy spring that walks down stairs, is an ideal medium for studying simple waves.

The original Slinkies were made of metal, but plastic ones are also available now. They are standard equipment in most physics storerooms, but you may have one left over from your childhood or that you can borrow from a younger acquaintance. Having your own Slinky handy can help you develop a feeling for wave phenomena. What kinds of waves can you generate with the Slinky?

### How do wave pulses travel down a Slinky?

If a Slinky is laid out on a smooth table with one end held motionless, you can easily produce a single traveling pulse on the Slinky. With the Slinky slightly stretched, move the free end back and forth once along the axis of the Slinky. As you do so, you will see a disturbance move from the free end of the Slinky to the fixed end (fig. 15.2).

The motion of the **wave pulse** created in this manner is easy to see. The pulse travels down the Slinky and may be reflected at the fixed end and come back toward its starting point before dying out. But what is actually moving? The pulse moves through the Slinky, and portions of the Slinky move as the pulse passes through them. After the pulse dies



**Figure 15.2** With one end of the Slinky fixed, a simple forward-and-back motion of the other end produces a traveling pulse.

out, though, the Slinky is exactly where it was before the pulse began. The Slinky itself has gone nowhere.

A closer look at what is happening within the Slinky can clarify the basic features of the pulse. Moving one end of the Slinky back and forth, as in figure 15.2, creates a local compression where the rings of the spring are closer together than in the rest of the Slinky. This region of compression moves along the Slinky and constitutes the pulse you see. Individual loops of the spring move back and forth as this region of compression goes by.

### Some general features of wave motion

A pulse in a Slinky shows some general features of wave motion. The wave or pulse moves through the medium (in this case, the Slinky) but the medium itself goes nowhere. Water waves move toward the beach, but water does not accumulate. What moves is a disturbance within the medium, which may be a local compression, a sideways displacement, or some other kind of local

change in the state of the medium. The disturbance moves with a definite velocity determined by properties of the medium.

In a Slinky, the speed of the pulse is determined partly by the tension in the Slinky. You can easily confirm this if you stretch the Slinky by different amounts and note the changes in the pulse velocity. The pulse travels faster when the Slinky is highly stretched than when it is only slightly stretched. The other factor that determines the pulse speed for the Slinky is the mass of the spring: For the same tension, a pulse travels more slowly on a steel Slinky than on a plastic one, because the mass for a given length of the spring is greater for steel than for plastic.

Transmission of energy through the medium is another general feature of wave motion. The work done in moving one end of the Slinky increases both the potential energy of the spring and the kinetic energy of individual loops. This region of higher energy then moves along the Slinky and reaches the opposite end. There, the energy could be used to ring a bell or to perform other types of work. Energy carried by water waves does substantial work over time in eroding and shaping a shoreline. This energy can be captured and converted to electric power, as discussed in everyday phenomenon box 15.1.

## Everyday Phenomenon

## Box 15.1

### Electric Power from Waves

**The Situation.** Anyone who has watched ocean waves in stormy weather is struck by the awesome power they possess. Even on a relatively calm day, the waves continuously move sand and batter any rocks in the vicinity (see photograph). Waves and wind constantly reshape the shoreline.

Is it possible to somehow harness the energy associated with ocean waves? Could we generate electric power from this readily available source of energy? Why do we not see wave-power generating plants along our coasts?

**The Analysis.** Ocean waves do indeed carry energy in the form of the kinetic energy of moving water. This energy is not highly concentrated; it is spread over large areas. Also, the velocities involved in the motion of the water are not very large. These factors, together with the corrosive effects of salt water, make the design of an economically viable wave-power generator a challenging problem. Given our need for sources of electric power that do not burn fossil fuels, several different possible designs of wave-power generators have been proposed in recent years.



moodboard/Glow Images

(continued)

## Debatable Issue

Wave-power installations would involve large buoys on the water surface and heavy apparatus and cables below the surface. Likewise, offshore wind-power installations have similar problems, with the additional problem of tall wind-turbine towers above the water surface. Local residents have often opposed these projects on aesthetic grounds, as well as on issues regarding possible negative effects on fish and other sea life. Should these concerns override the possible benefits of these energy resources?

### How do longitudinal and transverse waves differ?

The wave pulse we have described in the Slinky is called a *longitudinal* wave. In a longitudinal wave, the displacement or disturbance in the medium is *parallel* to the direction of

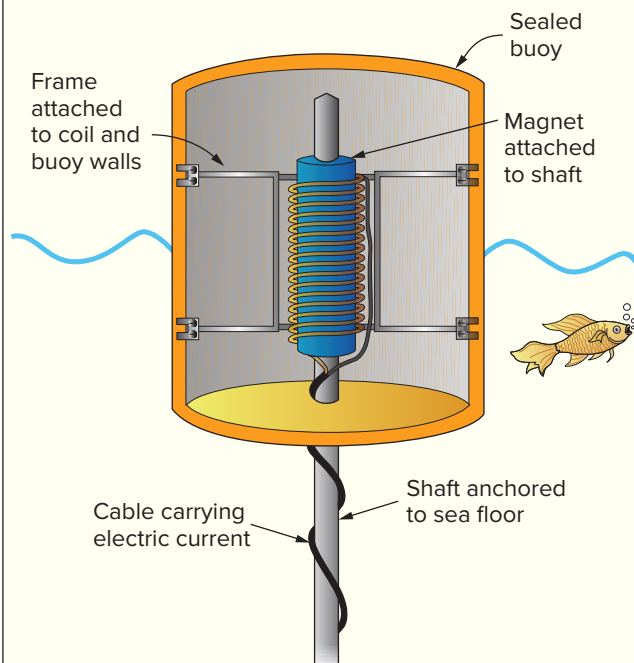
travel of the wave or pulse. In the Slinky, the loops of the spring move back and forth along the axis of the Slinky, and the pulse also travels along this axis.

You can also produce a *transverse* wave on a Slinky or spring. In a transverse wave, the disturbance or displacement is *perpendicular* to the direction the wave is traveling (fig. 15.3). If you move your hand back and forth perpendicular to the axis of the spring, you create a transverse pulse. This works best with a Slinky when it is highly stretched. A long, thin spring is actually more effective than a Slinky for producing transverse pulses or waves. Like the longitudinal pulse, the transverse pulse moves down the spring and transmits energy along the spring.

Waves on a rope, discussed in section 15.2, are generally transverse, as are electromagnetic waves, which will be discussed in the first section of chapter 16. Polarization

Away from the shore, the water near the surface moves mostly up and down under the influence of the waves, with some forward roll in the direction of the wave motion. A boat or other floating object will bob up and down as the waves pass by. Most proposals for wave-power generators involve capturing this energy at some distance from the shore rather than near the beach.

One of the most promising designs involves a buoy tethered to the ocean floor. The buoy has a built-in electric generator that moves in a linear fashion, as shown in the diagram. At the center of the buoy is a long magnet that is tied to the ocean



A simplified diagram of a proposed wave-power generator. A coil of wire attached to the floating buoy moves up and down over a magnet tethered to the ocean floor. ©Goodshoot/Punchstock RF

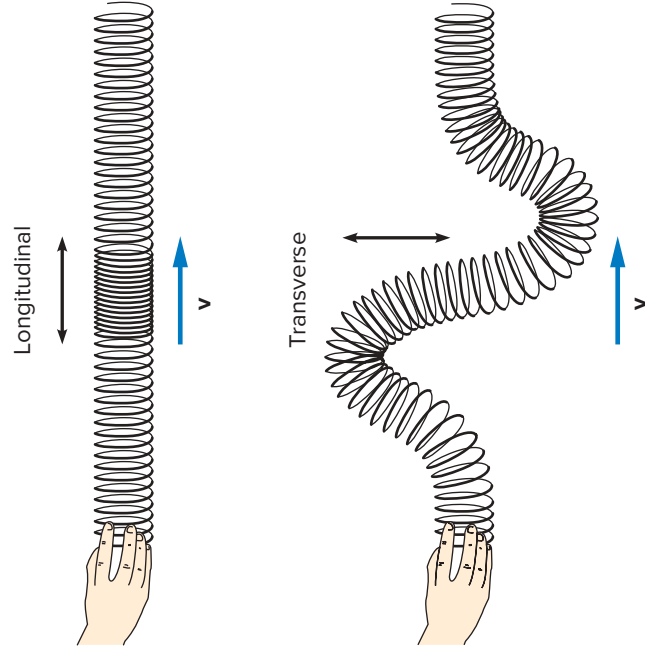
floor via the tether, so that it cannot move up and down. The floating portion of the buoy contains a large coil of wire centered on the magnet. This coil moves up and down as the waves move past the buoy.

As was discussed in chapter 14, a magnet moving through a coil of wire will generate a voltage described by Faraday's law. The size of this voltage depends on the strength of the magnetic field and the number of turns of wire in the coil. The stronger the magnet and the larger the coil, the greater the voltage. The direction of this voltage and the resulting electric current reverses when the motion of the buoy changes from up to down.

The electric generators described in section 14.5 involved rotational motion of the coil of wire. In most power plants, the generator is driven by a turbine that rotates at high speed. This naturally produces an alternating current that, by convention in the United States, has a frequency of 60 Hz. The up-and-down motion of the wave-driven buoy has a much lower frequency, however. For this reason, it is proposed that the current generated by the buoy be converted to direct current for transmission to the shore. (This process is called *rectification* and it is not difficult to do.)

The direct current would be transmitted by cables that ran down the tether of the buoy to the ocean floor, and from there, to the shore. On shore, there would be a power station that would receive the current from several buoys in a wave-generator "park." At this station, the direct current would be converted to 60-Hz alternating current, so that it could be transmitted over the electric power grid. Again, the circuitry needed to convert direct current to alternating current is standard equipment used in many other applications.

Many different ways of generating electric power from waves are being researched and tested in various parts of the world. Whether or not these ideas prove to be economically viable remains to be seen, but there is a good chance that wave power will be a reality in the future.



**Figure 15.3** In a longitudinal pulse, the disturbance is parallel to the direction of travel. In a transverse pulse, the disturbance is perpendicular to the direction of travel.

effects (section 16.5) are associated with transverse waves but not longitudinal waves. Sound waves (section 15.4) are longitudinal and are similar in many ways to longitudinal waves on a Slinky. Water waves have both longitudinal and transverse properties.

### What is a periodic wave?

Up to this point, we have discussed single wave pulses on a Slinky. If you move your hand back and forth several times, rather than just once, you will send a series of longitudinal pulses down the Slinky. If equal time intervals separate the pulses, you produce a **periodic wave** on the Slinky (fig. 15.4).

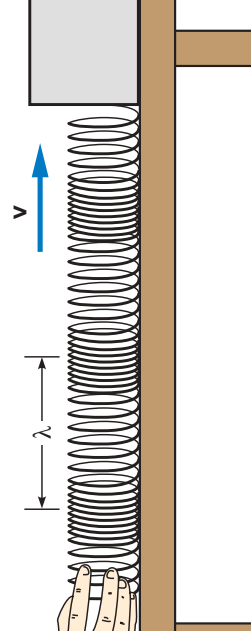
The time between pulses is called the *period* of the wave and is often represented by the symbol  $T$ . The *frequency* is the number of pulses or cycles per unit of time and is equal to the reciprocal of the period:

$$f = \frac{1}{T}$$

where the symbol  $f$  represents the frequency.

The same symbols and meanings were given to these quantities in chapter 6 (section 6.5) when we discussed simple harmonic motion. The unit of frequency is the hertz (Hz), where  $1 \text{ Hz} = 1 \text{ cycle per second}$ . (See example box 15.1.)

As the pulses move down the Slinky, they are spaced at regular distance intervals if they have been created at regular time intervals. The distance between the same points on successive pulses is called the **wavelength**. The commonly used symbol for wavelength is the Greek letter lambda,  $\lambda$ , as can be seen in figure 15.4.



**Figure 15.4** A series of pulses produced at regular time intervals generates a periodic wave on the Slinky. The wavelength  $\lambda$  is the distance between corresponding points on adjacent pulses.

A pulse in a periodic wave travels a distance of one wavelength in a time equal to one period before the next pulse is created. The speed of the wave can be expressed in terms of these quantities. The speed is equal to one wavelength (the distance traveled between pulses) divided by one period (the time between pulses), or

$$v = \frac{\lambda}{T} = f\lambda$$

The last portion of this equality is true because the frequency  $f$  is equal to  $1/T$ , the reciprocal of the period. These ideas are illustrated in example box 15.1.

This relationship is valid for any periodic wave and is useful for finding the frequency or wavelength when one of these quantities is known. The wave speed depends only on the properties of the medium. Often, the speed is known from other considerations: The speed of electromagnetic waves (section 16.1) in free space, for example, has a fixed value (the speed of light) that is independent of wavelength or frequency. The relationship between speed, wavelength, and frequency will be illustrated many times in the following sections.

## Example Box 15.1

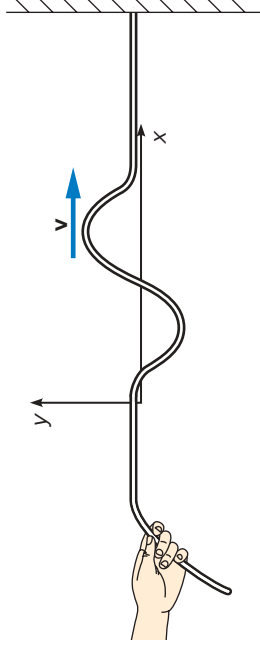
### Sample Exercise: Waves on a Slinky

A longitudinal wave traveling on a Slinky has a period of 0.25 s and a wavelength of 30 cm.

- What is the frequency of the wave?
- What is the speed of the wave?

$$\begin{aligned} \text{a. } T &= 0.25 \text{ s} & f &= \frac{1}{T} \\ & & &= \frac{1}{0.25 \text{ s}} \\ & & &= \mathbf{4 \text{ Hz}} \\ \text{b. } \lambda &= 30 \text{ cm} & v &= f\lambda \\ & & &= (4 \text{ Hz})(30 \text{ cm}) \\ & & &= \mathbf{120 \text{ cm/s}} \end{aligned}$$

A wave pulse is a disturbance that moves through some medium while the medium itself goes nowhere. If we move the end of a Slinky back and forth along its axis, we create a longitudinal pulse whose disturbance is an area of compression on the spring. If we wave the end of the Slinky up and down in a direction perpendicular to its axis, we create a transverse pulse. A periodic wave consists of several pulses spaced at regular intervals in time (the period) and space (the wavelength). The frequency is the reciprocal of the period, and the pulse speed is equal to the frequency times the wavelength.



**Figure 15.5** At any instant, a transverse pulse moves along a stretched rope, the shape of the rope can be thought of as a graph of the vertical displacement of the rope plotted against horizontal position.

## 15.2 Waves on a Rope

Imagine a heavy rope tied at one end to a wall or post. If you moved the free end of the rope up and down, you could create either a transverse wave pulse or a periodic transverse wave that would travel down the rope toward its fixed end. The situation is the same as producing a transverse wave on a Slinky or spring: Think of the rope as a very stiff spring.

What does the wave look like as it travels down the rope? In this case, the disturbance is a vertical displacement of the rope from its straight-line position. This disturbance is easy to visualize and graph, which is why the study of this type of wave is so useful for understanding wave phenomena.

### What does the graph of the wave look like?

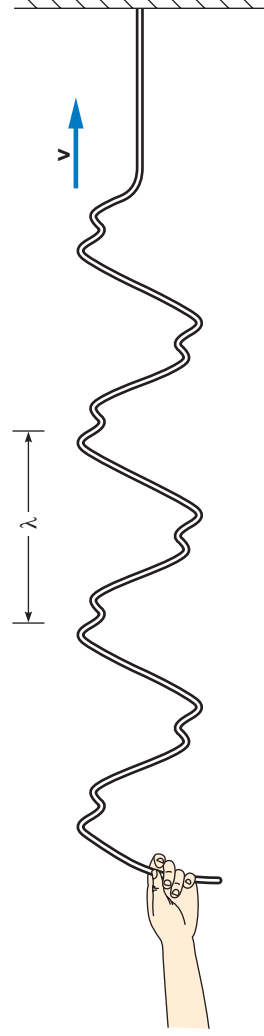
Suppose we give the end of the rope an up-and-down motion, producing a pulse like the one depicted in figure 15.5. The right edge of this pulse corresponds to the beginning of the motion. The left edge is the end of that motion. Like the pulse on the Slinky, this disturbance travels down the rope. In this case, however, the picture of the rope can be thought of as a graph, with the vertical axis representing the vertical displacement  $y$  of the rope and the horizontal axis the horizontal position  $x$  of a point on the rope.

A single picture of the pulse on the rope does not tell the whole story—it is like a snapshot showing the displacement

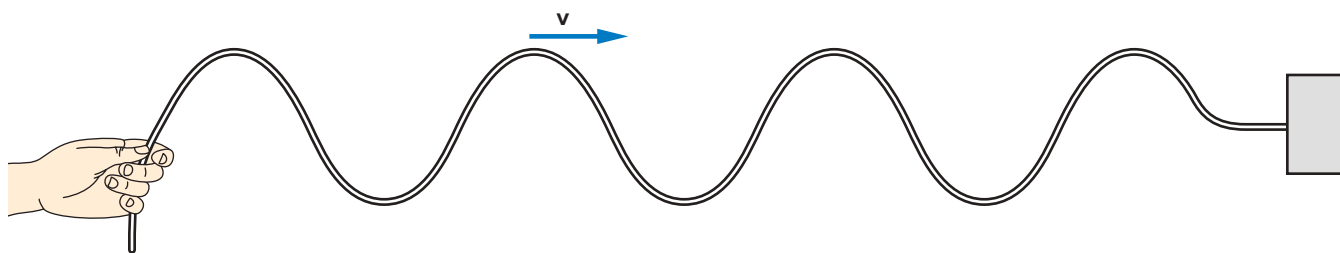
of the rope at only one instant in time. The pulse is moving, so at some later time the pulse will be farther down the rope at a different horizontal position. We would have to draw a series of graphs at different times to represent this. The pulse may gradually decrease in size because of frictional effects, but the shape remains basically the same as the pulse moves along the rope.

If, instead of giving the rope just one up-and-down motion, you repeated a series of identical pulses at regular time intervals, you could produce a periodic wave like the one shown in figure 15.6. The wavelength  $\lambda$  (shown on the graph) is the distance covered by one complete cycle of the wave. This wave pattern moves to the right along the rope, retaining its shape, just as the single pulse did. When the leading edge of the wave reaches the fixed end of the rope, it will be reflected and start to move back toward your hand. As this happens, the reflected wave interferes with the wave still traveling toward the right, and the picture becomes more complex.

The shape of the wave in figure 15.6 depends on the exact motion of the hand or other oscillator generating the wave. The wave could be much more complex than the shape shown. One particularly simple shape plays an important role in the analysis of wave motion. If you move your hand up and down smoothly in simple harmonic motion, the displacement of this end of the rope will vary sinusoidally with time, as discussed in chapter 6. The resulting periodic wave also has a sinusoidal form, and we call it a **harmonic wave** (fig. 15.7).



**Figure 15.6** A periodic wave moving along a stretched rope. The distance between pulses is the wavelength  $\lambda$ .



**Figure 15.7** A harmonic wave results when the end of the rope is moved up and down in a simple harmonic motion.

Like other waves, the sinusoidal wave shown in figure 15.7 travels along the rope until it is reflected at the fixed end. If you move the end of the rope carefully, you can produce a wave that looks like the one shown in figure 15.7. The individual segments of a rope or spring tend to move with simple harmonic motion, because the restoring force pulling the rope back toward the center line is roughly proportional to its distance from the center line. This was the condition for simple harmonic motion discussed in chapter 6.

Harmonic waves play an important role in the discussion of wave motion for another reason—it turns out that any periodic wave can be represented as a sum of harmonic waves with different wavelengths and frequencies. We call this *Fourier*, or *harmonic, analysis*, which is the process of breaking a complex wave down into its simple harmonic components (see section 15.5). Harmonic waves can be thought of as building blocks of more complex waves.

### What determines the speed of a wave on a rope?

Like the waves on a Slinky, the waves on a string or rope move along the rope with a speed independent of the shape or frequency of the pulses. What determines this speed? To answer this question, we need to think about what causes the disturbance to propagate along the rope. Why do the pulses move?

If we picture just a single pulse moving along the rope, we note that segments of the rope lying in front of this pulse are at rest before the pulse gets there. Something must cause these segments to accelerate as the pulse approaches. The reason the pulse moves is that lifting the rope causes the rope's tension (which is a force acting along the line of the rope) to acquire an upward component. This upward component acts on the segment of the rope to the right of the raised portion, as in figure 15.8. The resulting upward force causes this next segment to accelerate upward, and so on down the rope.

The speed of the pulse depends on the rate of acceleration of succeeding segments of the rope—the faster they can be started moving, the more rapidly the pulse moves down the rope. By Newton's second law, this acceleration is proportional to the magnitude of the net force, and inversely proportional to the mass of the segment ( $\mathbf{a} = \mathbf{F}_{\text{net}}/m$ ). The tension in the rope provides the accelerating force, so a larger tension produces a larger acceleration. The acceleration is also related to the mass of the segment—a greater mass produces a

smaller acceleration. These ideas suggest that the speed of a pulse on the rope will increase with the tension in the rope and decrease with the mass per unit of length of the rope.

Actually, the square of the speed is directly related to the ratio of the tension to the mass per unit of length,  $v^2 = F/\mu$ , so the expression for the wave speed involves a square root:

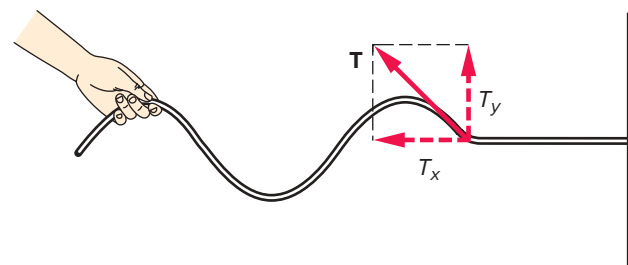
$$v = \sqrt{\frac{F}{\mu}}$$

where  $F$  is the magnitude of the tension in the rope (a force), and  $\mu$  is the Greek letter mu, often used to represent mass per unit of length. This quantity is found by dividing the total mass of the rope by its length, or  $\mu = m/L$ .

If you increase the tension by pulling harder on the rope, you can expect the wave speed to get larger, just as it did for the Slinky. On the other hand, a thick rope, with a large mass per unit of length, will produce a slower wave speed than a lighter rope. For this reason, a heavy rope is more effective for demonstrating wave motion than a light string. The waves move too swiftly on a light string for us to follow them visually.

### What determines the frequency and wavelength of the wave?

The expression relating the wave speed to the frequency and wavelength ( $v = f\lambda$ , from section 15.1) is useful for predicting what wavelength will result for a wave on a rope. As we have just seen, the speed depends on the tension and the mass per unit of length. Once these quantities have been fixed, the wave speed is constant but the frequency and wavelength may vary. A given frequency will determine the wavelength, and vice versa.



**Figure 15.8** As the raised portion of a pulse approaches a given point on the rope, the tension in the rope acquires an upward component. This causes the next segment to accelerate upward.

These ideas are demonstrated in example box 15.2. The numerical values in this example are realistic for producing waves that can be followed visually. The assumed tension of 50 N should be large enough to keep the heavy rope from sagging too much while producing a relatively slow wave speed. The wave frequency is determined by the frequency of motion of your hand. This frequency is 4 cycles per second (Hz) in example box 15.2, which gives a wavelength of 3.95 meters. Because this is almost 4 meters, two-and-a-half complete cycles of the wave will fit along the 10-meter length of the rope. Lower frequencies would result in longer wavelengths and higher frequencies in shorter wavelengths.

With a wave speed of almost 16 m/s, it takes less than a second for a pulse to travel the 10-meter length of the rope. To observe these waves, you will need to look quickly, because within a second the wave will reach the fixed end of the rope and be reflected. This reflected wave will interfere with the wave still traveling in the original direction. You would need either a longer rope or some means of damping out the reflected wave if you wanted a more leisurely view.

The real advantage of waves on a rope is the ease with which we can picture them graphically and get a physical sense of how they are produced. In lecture or laboratory demonstrations, a long but not very stiff spring is often used instead of the rope to provide a larger mass per unit of length and a slower wave speed.

### Example Box 15.2

#### Sample Exercise: Making Waves

A rope has an overall length of 10 m and a total mass of 2 kg. The rope is stretched with a tension of 50 N. One end of the rope is fixed, and the other is moved up and down with a frequency of 4 Hz.

- What is the speed of waves on this rope?
- What is the wavelength for the frequency of 4 Hz?

$$\begin{aligned} \text{a. } L &= 10 \text{ m} & \mu &= \frac{m}{L} = \frac{2 \text{ kg}}{10 \text{ m}} \\ m &= 2 \text{ kg} & &= 0.2 \text{ kg/m (mass per unit of length)} \\ F &= 50 \text{ N} & & \\ v &= ? & v &= \sqrt{\frac{F}{\mu}} \\ & & &= \sqrt{\frac{50 \text{ N}}{0.2 \text{ kg/m}}} \\ & & &= \sqrt{250 \text{ m}^2/\text{s}^2} \\ & & &= \mathbf{15.8 \text{ m/s}} \end{aligned}$$

$$\begin{aligned} \text{b. } f &= 4 \text{ Hz} & v &= f\lambda \\ \lambda &= ? & \lambda &= \frac{v}{f} \\ & & &= \frac{15.8 \text{ m/s}}{4 \text{ Hz}} \\ & & &= \mathbf{3.95 \text{ m}} \end{aligned}$$

A snapshot of a wave moving on a rope is like a graph showing the vertical displacement of the rope plotted against position. This picture shows the wave at only one instant in time, however, because the wave pattern is moving. The speed of the wave increases with increasing tension and decreases with increasing mass per unit of length of the rope. The frequency is determined by how rapidly you move your hand. The speed and the frequency determine the wavelength.

## 15.3 Interference and Standing Waves

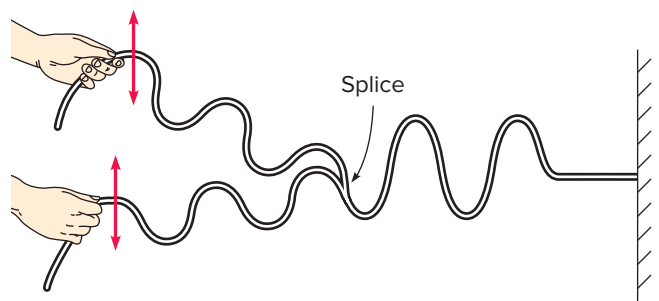
When a wave on a rope reaches the fixed end of the rope, it is reflected and travels in the opposite direction back toward your hand. If only a single pulse is involved, you can see the returning pulse quite clearly. If the wave is a longer periodic wave, though, the reflected wave *interferes* with the incoming wave. The resulting pattern becomes more complex and confusing.

When waves of water approach a beach, waves reflected at the beach interfere with those coming in and create a more complex pattern than the waves at some distance from the beach. This process, in which two or more waves combine, is called **interference**. What happens when waves interfere? Can we predict what the resulting wave pattern will be?

### How do two waves on a rope combine?

Waves on a rope give examples of interference that are easy to visualize and useful in highlighting the basic concepts. Imagine a rope that consists of two identical segments smoothly spliced to form a single rope *of the same mass per unit length* as the original two segments (fig. 15.9). If you hold one segment in your left hand and the other in the right, you can generate waves on each segment that will combine when they reach the junction.

If you move both hands up and down in the same way, the waves generated on each segment of the rope should be identical. What happens when they reach the junction? Because each wave by itself would generate a disturbance equal



**Figure 15.9** Identical waves, traveling on two identical ropes that are spliced together, combine to produce a larger wave.



to its own height, we might assume that the combined effect of the two waves will produce a wave with the same frequency and wavelength but *twice* the height of the initial two waves. In fact, this is what happens: The double-height wave proceeds down the single rope to the right of the splice.

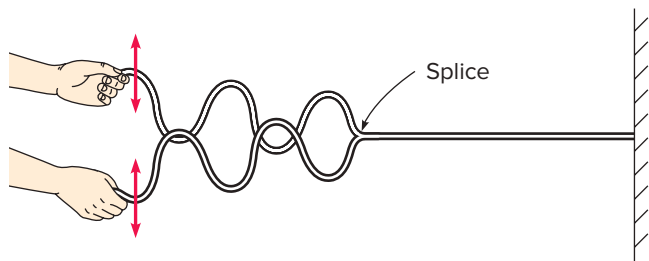
The idea that we can find the total effect when two or more waves interfere by simply adding their individual displacements is called the **principle of superposition**.

This principle is valid for most types of wave motion. In some situations, the resulting disturbance might be so large that the medium in which the wave is traveling cannot fully respond. The net disturbance in this case is less than what the principle of superposition predicts. For most situations, however, the principle of superposition holds. It is the basis for analyzing all interference phenomena.

When two or more waves combine, the resulting disturbance or displacement is equal to the sum of the individual disturbances.

When two waves are moving the same way at the same time, as in figure 15.9, they are said to be *in phase*. When they reach the junction, both waves are going up or down at the same time. We can, however, produce waves that are not in phase with each other. If you move the two segments so that one is going up while the other is going down, for example, the two resulting waves are said to be *completely out of phase* with each other (fig. 15.10). What happens in this situation? If the two waves have the same height, the principle of superposition predicts that the net disturbance will be zero. When the displacements of the two waves are added at the junction, the displacement of one is positive (up), while the other is negative (down), and they cancel each other. The sum is always zero, and no wave is propagated beyond the junction.

The result of adding two or more waves depends on their phases as well as on their *amplitude*, or height. The two situations we have depicted with the spliced rope are the extremes—in one case, the waves are completely in phase, and in the other, they are completely out of phase. In the first case, we get complete addition, or *constructive interference*. In the other, we get complete cancellation, or *destructive interference*. It is also possible for the two waves to be neither



**Figure 15.10** Two waves, exactly out of phase in their up-and-down motions, combine to produce no net disturbance on the rope beyond the splice.

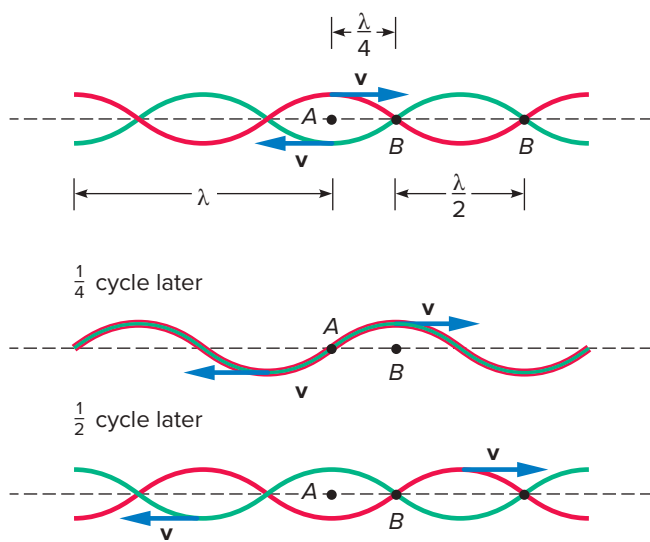
completely in phase nor completely out of phase but somewhere in between. In these situations, the resulting wave has a height somewhere between zero and the sum of the two initial heights.

### What is a standing wave?

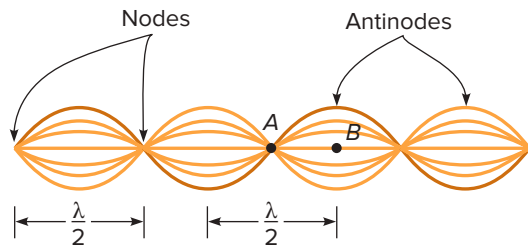
Although it is difficult to get two waves traveling in the same direction on separate ropes to combine, interference of two or more waves traveling in the same direction is quite common for water waves, sound waves, and light waves. The difference in phase between the waves determines whether the interference will be constructive, destructive, or somewhere in between, just like the waves on the rope. What does occur with waves on ropes or strings is the interference of two waves traveling in *opposite* directions, which happens when the waves are reflected at a fixed support. How do the waves combine in this situation?

Figure 15.11 shows two waves of the same height and wavelength traveling in opposite directions on a string. We can apply the principle of superposition by selecting different points on the string and considering how these two waves add at different times. At point A, for example, the two waves will cancel each other at all times. One wave is positive, while the other is negative by an equal amount at all times as the two waves approach this point from opposite sides. At this point, the string will not oscillate at all.

If we move one-quarter of a wavelength in either direction from point A, we see a very different result. At point B, for example, both waves will be in phase at all times as they approach from opposite sides. When one is positive,



**Figure 15.11** Two waves of the same amplitude and wavelength are shown traveling in opposite directions on a string. The middle drawing shows the two strings at a time a quarter period after the upper drawing, and the bottom drawing a half period after the upper drawing. A node results at point A and an antinode at point B when the waves combine.



**Figure 15.12** The pattern produced by two waves traveling in opposite directions in figure 15.11 is called a *standing wave*. (The position of the string is shown at several different times.) The distance between adjacent nodes or antinodes is half the wavelength of the original waves.

so is the other, and so on. At this point, the two waves always add, producing a displacement twice that of each wave by itself.

What is notable about these two points is that they remain fixed in space along the string. Point A, at which there is no motion, is called a **node**. There are nodes at regular intervals along the string, separated by half the wavelength of the two traveling waves. You can confirm this by moving half a wavelength in either direction from point A and seeing that the two waves cancel at these points also. These nodes do not move.

The same is true for points such as B, where the waves add to yield a large height, or amplitude. These points are called **antinodes**, and they are also found at fixed locations separated by half a wavelength along the string. The resulting pattern is shown in figure 15.12, which shows the string position at several different times. The two waves traveling in opposite directions produce a fixed pattern with regularly spaced nodes and antinodes. At the antinodes, the string is oscillating with a large amplitude. At the nodes, it is not moving at all. At points between the nodes and antinodes, the amplitude has intermediate values.

This pattern of oscillation of the string is called a **standing wave**, because the pattern does not move. The two waves that produce this pattern are *moving* in opposite directions. They interfere, however, in a way that produces a standing or fixed pattern. Standing waves can be observed for all types of wave motion and always involve the interference of waves traveling in opposite directions. The interference of a reflected wave with an incoming wave is usually how this happens.

### What determines the frequency of a wave on a guitar string?

A guitar, a piano, or any other stringed instrument is made of strings or wires of different weights that are fixed at both ends, with tuning pegs to adjust the tension. A wave generated by plucking the string is reflected back and forth on the string, producing a standing wave.

The frequency of the sound wave produced by the string equals the string's frequency of oscillation, and this frequency

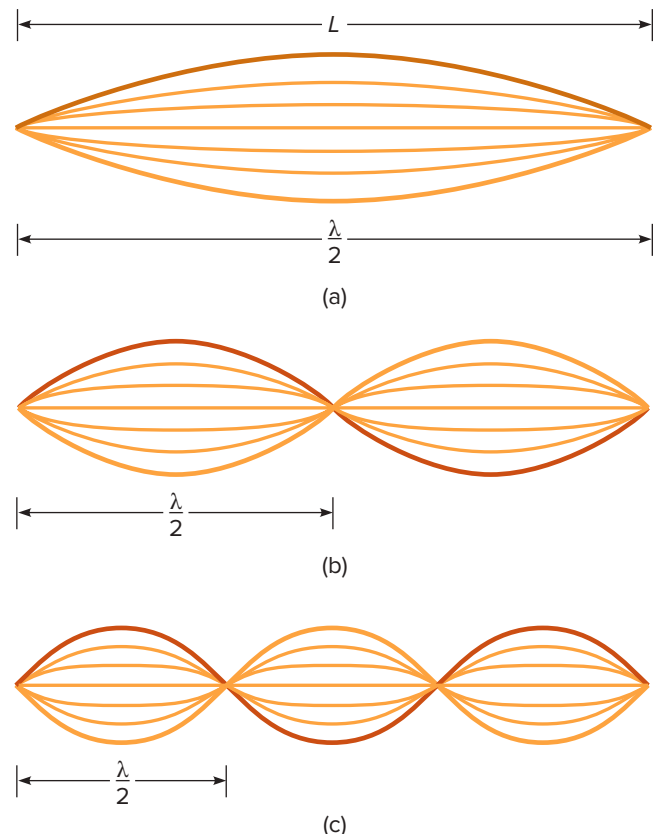
is related to the musical **pitch** that we hear. *Pitch* is a musical term meaning how high or low a tone sounds. A higher frequency represents a higher-pitched note. What conditions determine the frequency of the guitar string? How are standing waves involved?

The standing wave on a plucked guitar string has nodes at both ends. The string is fixed at both ends and cannot oscillate at these points. The simplest standing wave is one with nodes at either end and an antinode in the middle (fig. 15.13a). This standing wave usually results when the string is plucked. Because the distance between nodes is half the wavelength of the waves interfering to produce the standing wave, the wavelength of these interfering waves must be twice the length of the string ( $2L$ ) in this case.

This simplest standing wave is called the *fundamental wave*, or the *first harmonic* (fig. 15.13a). The wavelength of the interfering waves is determined by the length of the string. The frequency can be found from the relationship between speed, frequency, and wavelength,  $v = f\lambda$ . The speed is determined by the tension in the string  $F$  and the mass per unit of length of the string  $\mu$ , as discussed in section 15.2.

The frequency of the fundamental wave is

$$f = \frac{v}{\lambda} = \frac{v}{2L}$$



**Figure 15.13** The first three harmonics are the three simplest standing-wave patterns that can be generated on a guitar string fixed at both ends. String positions are shown at several different times, as indicated by multiple lines between the nodes.

A string with a longer length  $L$  will result in a lower frequency, which is why the bass strings on a piano are much longer than the treble strings. On a guitar, you can change the effective length of the strings by *fretting* them—that is, by placing your finger firmly on the string along the neck of the guitar. Shortening the effective length of the string produces a higher frequency and a higher-pitched tone.

Other factors that affect the frequency are the tension in the string and the mass per unit length of the string, which together determine the wave speed. A higher tension leads to a higher wave speed and a higher frequency. You can easily confirm this by tightening a tuning peg on a guitar. A heavier string, on the other hand, produces a lower wave speed and a lower frequency. The bass strings on a steel-string guitar or piano are made by wrapping wire around a core wire to produce a larger mass per unit of length.

Although the fundamental frequency for a guitar string dominates if you just pluck the string near the middle, you can also produce the other two patterns shown in figure 15.13, as well as patterns with even more nodes. To produce the second harmonic, for example, you touch the string lightly at the midpoint at the same time you pluck the string. This creates the pattern shown in figure 15.13b, with nodes at the center and at either end. The wavelength of the interfering waves for this pattern is equal to the length  $L$  of the string. Because this wavelength is half the fundamental, the resulting frequency is twice the fundamental, as shown in example box 15.3. Musically, the pitch produced by doubling the frequency is an octave above the fundamental (see section 15.5).

### Example Box 15.3

#### Sample Exercise: Waves and Harmonics

A guitar string has a mass of 4 g, a length of 74 cm, and a tension of 400 N. These values produce a wave speed of 274 m/s.

1. What is its fundamental frequency?
2. What is the frequency of the second harmonic?

$$\begin{aligned} \text{a. } L &= 74 \text{ cm} = 0.74 \text{ m} & f_1 &= \frac{v}{\lambda_1} = \frac{v}{2L} \\ v &= 274 \text{ m/s} & &= \frac{274 \text{ m/s}}{1.48 \text{ m}} \\ \lambda &= 2L & &= \mathbf{185 \text{ Hz}} \\ f_1 &= ? & & \end{aligned}$$

$$\begin{aligned} \text{b. } \lambda &= L & f_2 &= \frac{v}{\lambda_2} = \frac{v}{L} \\ f_2 &= ? & &= \frac{274 \text{ m/s}}{0.74 \text{ m}} \\ & & &= \mathbf{370 \text{ Hz}} \end{aligned}$$

(Notice that  $f_2 = 2f_1$ .)



**Figure 15.14** The strings on a steel-string guitar have different weights. The top bass string has been plucked, producing a blur near the middle where the amplitude is greatest. *Jill Braaten*

If you touch the string lightly at a position one-third the length of the string from one end, you get the pattern in figure 15.13c, which has four nodes (counting those at either end) and three antinodes. The resulting frequency is three times the fundamental and  $\frac{3}{2}$  that of the second harmonic. Musically, this is not a complete octave above the second harmonic but rather an interval called a *fifth* above that pitch.

Guitars are common fixtures in many student rooms. If you have one handy, try generating some of these harmonics and noting the pitch that results. It requires no particular skill as a musician and will help to clarify these ideas. If you look closely at the string, you can see the standing wave patterns (fig. 15.14). The patterns are often easier to see when illuminated by a fluorescent light.

When two or more waves combine, their disturbances add according to the principle of superposition. If they are in phase, the resulting interference is constructive. If they are completely out of phase, the waves cancel one another and the interference is destructive. If the waves are traveling in opposite directions, this interference produces a standing-wave pattern with fixed positions for the nodes and antinodes. This is what happens on a guitar string. The length of the string and the form of the standing-wave pattern determine the wavelength. The wavelength determines the frequency because the wave speed is set by the tension and mass of the string.

## 15.4 Sound Waves

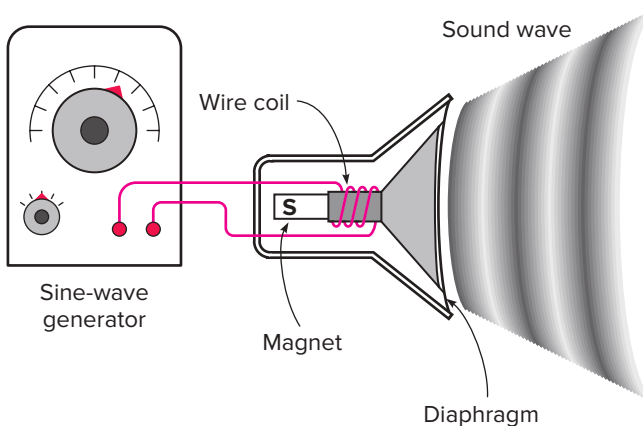
Sound waves can be generated by an oscillating string on a guitar or piano, but you certainly can think of many other ways of producing such waves. Firing a pistol, using your voice, or banging on a metal pot with a stick will all do the job. Small children are experts at finding ways of generating sound waves—the louder the better.

Because sound waves reach our ears, they must be able to travel through air. How do they travel through air? How fast do they travel? Can they interfere like waves on a string to form standing waves?

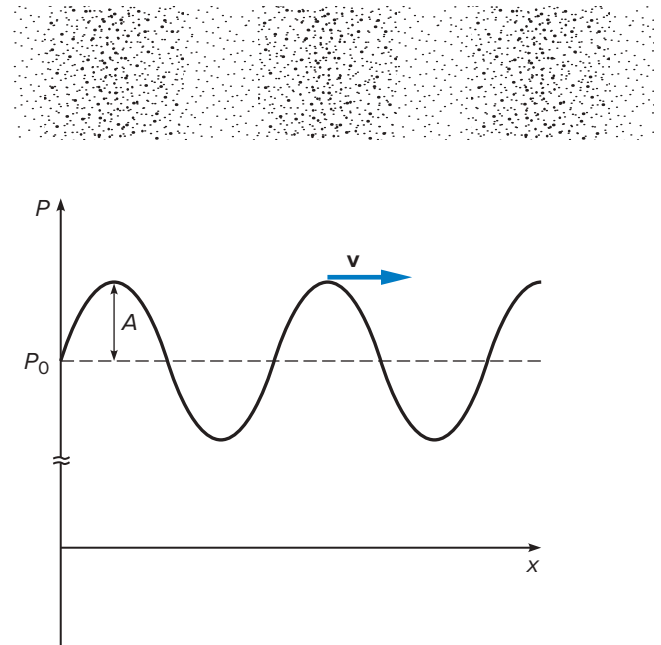
### What is the nature of a sound wave?

If you look closely at one of the speakers used in your stereo system or car radio, you will see a mechanism like that shown in figure 15.15. A flexible, cardboardlike material (the diaphragm) is mounted in front of a permanent magnet fixed to the housing of the speaker. A coil of wire is attached to the base of the diaphragm, so that it is centered on the end of the permanent magnet. An oscillating current applied to the wire coil causes it to behave like an electromagnet, alternately attracted to and repelled by the permanent magnet. The diaphragm then oscillates with the same frequency as the applied electric current.

What effect does the oscillating diaphragm have on nearby air? As the diaphragm moves forward, it compresses the air in front of it. As it moves backward, it produces a region of lower pressure. The compressed region, in turn, pushes against air in front of it, increasing the pressure there. This region of increased pressure propagates through the air, as do the regions of reduced pressure. The disturbance could take the form of a single pulse, but if the diaphragm is moving back and forth repeatedly, it produces a continuous periodic wave consisting of pressure variations.



**Figure 15.15** An oscillating current applied to the coil of wire attached to the diaphragm of a speaker makes the diaphragm oscillate as it is attracted to or repulsed by the magnet, generating a sound wave in the air.



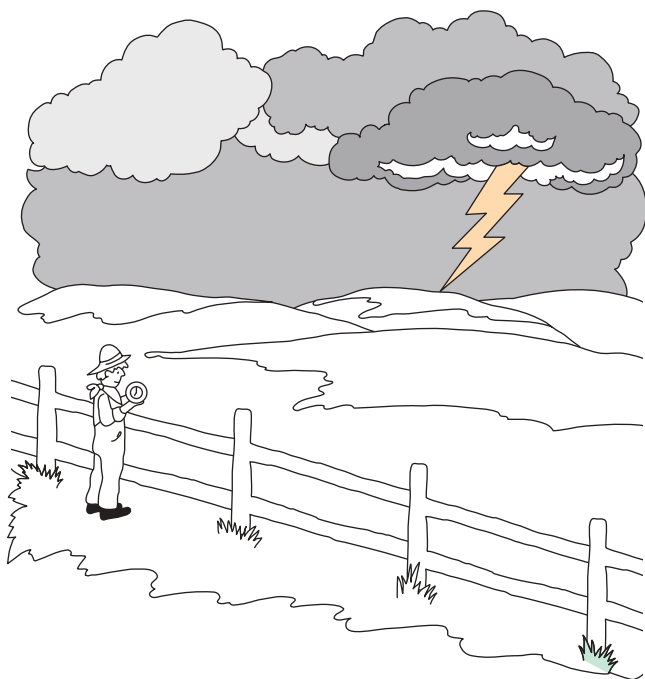
**Figure 15.16** Variations in air pressure (and density) move through the air in a sound wave. The graph shows pressure plotted against position. The amplitude of the wave is represented by  $A$ , and the vector  $\mathbf{v}$  represents the wave velocity.

This wave of pressure variations is a **sound wave**. In the regions of elevated pressure, the molecules in the air are closer together, on average, than they are in the regions of reduced pressure. Figure 15.16 shows a sound wave with the variations in air density exaggerated. Below the picture of the wave is a graph of pressure versus position. For a simple harmonic wave, this pressure graph has a simple sinusoidal form. The size of the variation in pressure, identified as the amplitude  $A$  on the graph, is related to the loudness of the sound wave. To complete the illustration, imagine that the whole pattern is moving away from the source, where new regions of elevated and reduced pressure are being constantly generated.

The molecules making up air are in constant motion in all directions, as is true in any gas. Besides random motion, however, there must be a back-and-forth motion of the molecules along the line of the wave's path to create the regions of higher and lower density. A sound wave is therefore a *longitudinal* wave. The displacement of the molecules is parallel to the direction of propagation of the wave, much like on a Slinky when one end is moved back and forth. The coils of the Slinky move back and forth along the direction of propagation just as the molecules in the air do, and there are moving regions of increased density (compression) in the Slinky just as in the air.

### What determines the speed of sound?

How fast do sound waves travel, and what factors determine the speed of sound? The first half of this question turns out to be easier to answer than the second. In room-temperature air, sound waves travel with a speed of



**Figure 15.17** You can estimate the distance from a lightning strike by timing the interval between the lightning flash and the associated clap of thunder. (It takes approximately 5 seconds for the sound wave to travel 1 mile.)

approximately 340 m/s (1100 ft/s), or roughly 750 miles per hour (MPH). If you have ever watched from a distance as someone pounded a nail, you probably noticed that the sound reached your ear a split second after you saw the collision of hammer and nail. If you stand at the finish line of a 100-meter dash, you see the flash of the starter's pistol before you hear the shot. Sound travels quickly but not nearly as fast as light (see section 16.1).

Similarly, you hear a clap of thunder a few seconds after you see the flash of lightning. Because light travels extremely fast, the light flash reaches you almost instantaneously. The sound wave, on the other hand, takes about 3 seconds to cover 1 kilometer (or 5 seconds to cover 1 mile), given the value for the speed of sound just stated. Counting seconds between the flash and the thunder tells you how far away the lightning strike happened (fig. 15.17). If the flash and the thunderclap occur almost simultaneously, you may be in trouble!

The factors that determine the speed of sound are related to how rapidly one molecule transmits changes in velocity to nearby molecules to propagate the wave. In air, temperature is a major factor, because air molecules have higher average velocities at higher temperatures and collide more frequently. An increase in temperature of 10°C increases the speed of sound by about 6 m/s.

For gases other than air, the masses of the molecules or atoms make a difference in the speed of propagation. Hydrogen or helium molecules, with their small mass, are easier to

accelerate than the nitrogen or oxygen molecules that are the main ingredients of air. The speed of sound in hydrogen is almost four times larger than in air for similar pressures and temperatures.

Sound waves can also travel through liquids and solids, often with considerably higher speeds than for gases. The speed of sound in water, for example, is 4 to 5 times faster than in air. Molecules of water are much closer together than molecules in a gas, so the propagation of a wave does not depend on random collisions. Sound travels even more rapidly through a steel bar or other metals in which the atoms are rigidly bound within a crystal lattice. Sound waves in rock or metal generally have speeds 4 to 5 times faster than in water, and 15 to 20 times faster than in air.

If someone strikes a long steel rail with a hammer at one end and you listen for the sound at the other end, you may hear two bangs. The first one comes to you through the steel rail itself and reaches your ear a moment before the second one, which comes through the air. The actual difference in time will depend on how far you are from the hammer blow. Motion of the source or observer can also affect what we hear, as is described in everyday phenomenon box 15.2.

### Making music with soft-drink bottles

Can we observe interference phenomena such as standing waves in sound waves? We can indeed—playing many musical instruments depends on creating standing waves in a tube or pipe. An organ pipe, a clarinet barrel, and the several meters of metal tubing in a tuba all serve that purpose. A soft-drink bottle is the handiest example for observing this phenomenon. The length of the air column in the bottle can be varied by adding liquid to the bottle, as in figure 15.18.

If you place your lips near the edge of a soft-drink bottle, as in figure 15.18, and blow softly across the opening, the



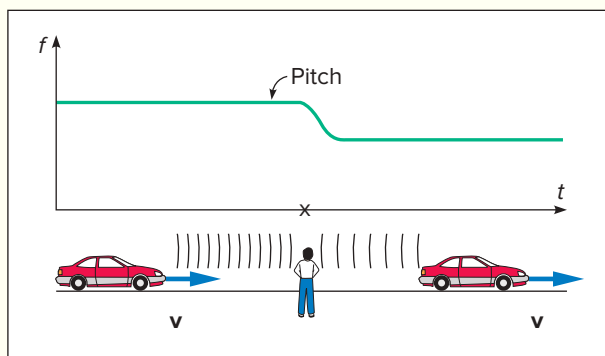
**Figure 15.18** Placing your lower lip at the rim of a soft-drink bottle and blowing softly across the opening produces a standing wave in the bottle. *Dave King/Dorling Kindersley/Getty Images*

## Everyday Phenomenon

## Box 15.2

## A Moving Car Horn and the Doppler Effect

**The Situation.** We have all had the experience of standing near a busy street and hearing someone lean on his or her car horn while driving by. If you remember how that sounds and try to mimic the sound, you will hum at one pitch to represent the car horn as it is nearing you and then at a lower pitch after the car has passed. In other words, you hear a lower-frequency sound wave after the car has passed than when it is approaching, as in the drawing.



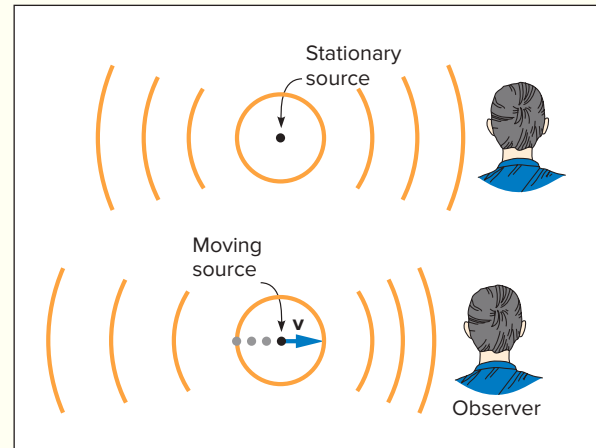
The pitch of the car horn seems to change from higher to lower as the car passes.

Does the frequency of the sound wave produced by the car horn actually change? This hardly seems likely. Something about the motion of the car and the horn must affect the frequency of the pitch that we hear. How can we explain this change in frequency?

**The Analysis.** The top half of the second diagram shows the wave crests or wavefronts of the car horn when the car is not moving. Each curve represents a surface along which air pressure is at its maximum in the pressure variations associated with the sound wave. The distance between these curves is the wavelength of the sound wave. The wavelength is determined by the frequency of the horn and the speed of sound in air. The wave speed dictates how far a crest will move in a given time, while the frequency of the horn determines when the next crest will appear.

The frequency we hear is equal to the rate at which the wave crests reach our ear, which is determined by the distance between the wave crests (the wavelength) and by the wave speed. You can think of these wave crests as impinging on your ear in much the same way that water waves wash up on the shore. The greater the speed, the greater the rate at which the wave crests reach your ear. The longer the wavelength, however, the smaller the rate (frequency) at which they reach the ear ( $v = f\lambda$ , or  $f = v/\lambda$ ).

What happens when the horn is moving? The lower portion of the diagram shows the case in which the horn is moving toward the observer. Between the times that one crest and the next are



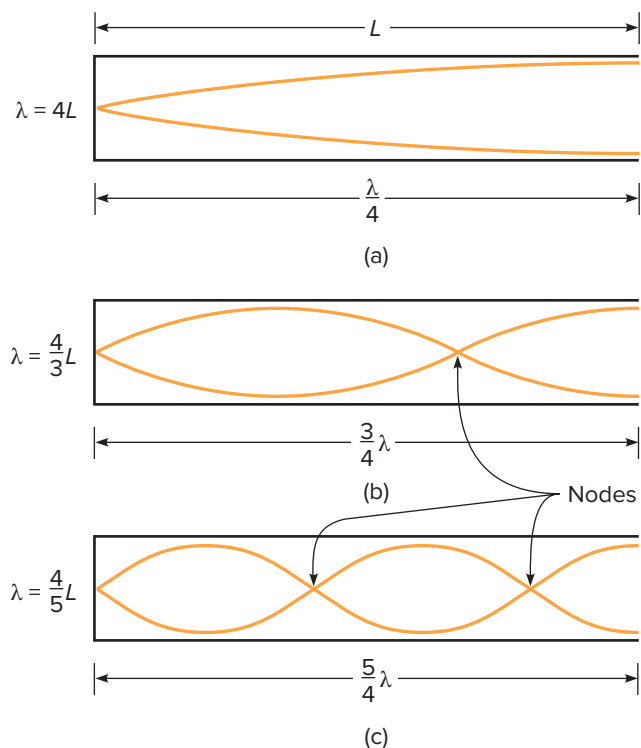
Wavefronts for a stationary car horn (top) and for one that is moving toward the observer (bottom). Motion of the source changes the wavelength on both sides of the source.

emitted by the horn, the horn has moved a short distance. As the diagram shows, this movement shortens the distance between successive wave crests. Even though the horn is still emitting the same frequency as before, the wavelength of the sound wave traveling toward the observer is now shorter.

Because the wavelength of the waves traveling toward the observer is shorter than what is produced by the stationary horn, the wave crests now reach your ear at a higher rate. There is less distance between wave crests, but the waves are still moving at the same speed as before. The higher rate at which the wave crests reach your ear is detected by the ear as a higher frequency. The frequency of the horn that you hear when the horn is moving toward you is higher than what you hear when the horn is stationary. This change in the detected frequency of a wave resulting from the motion of either the source or the observer is called the **Doppler effect**.

Using similar reasoning, you can see that the wavelength in air will get longer if the horn is moving away from you. A longer wavelength will produce a lower frequency as detected by the observer. For the moving car, the frequency that you hear as the car is approaching is higher than the natural frequency of the horn, and what you hear as the car is receding from you is lower than the natural frequency.

There is also a Doppler effect if the observer is moving relative to the air in which the wave is traveling. If the observer is moving toward the wave source, he or she will intersect wave crests more rapidly than if stationary and detect a higher frequency than the natural frequency. A receding observer detects a lower frequency. The Doppler effect occurs for light and other types of wave motion as well, but it is most familiar in the common experience of listening to moving vehicles.



**Figure 15.19** The standing-wave patterns for the first three harmonics are shown for a tube open at one end and closed at the other. The curves represent the amplitude of back-and-forth molecular motion at each point in the tube.

sound wave reflected from the bottom of the bottle interferes with the incoming wave to produce a standing wave in the bottle. Because the bottle is closed at one end, there should be a displacement node at the bottom of the bottle. (A displacement node is one where there is no longitudinal motion of the air.) On the other hand, we expect a displacement antinode somewhere near the opening of the bottle, because that is where we are exciting the oscillation.

The simplest standing wave that can exist in a pipe open at one end varies in displacement amplitude similar to the one plotted in figure 15.19a. The curved line is a graph of the displacement amplitude plotted against position. It is a measure of how far the molecules move back and forth, on average. There is a node at the closed end and an antinode near the open end. Because there is just a quarter-wavelength distance between a node and an antinode, the wavelength of the sound waves interfering to form this standing wave must be approximately four times the length of the tube.

We can determine the frequency of this standing wave from the speed of sound in air (about 340 m/s) and the wavelength. For a tube 25 cm in length (more or less the length of a 16-oz soft-drink bottle), the wavelength of the interfering sound waves is about 1 meter ( $4L$ ). Because  $f = v/\lambda$ , this should produce a frequency of

$$f = \frac{340 \text{ m/s}}{1 \text{ m}} = 340 \text{ Hz}$$

Because a soft-drink bottle is not a simple pipe with straight sides, the frequency produced by a bottle may differ slightly from this estimate, but frequencies near 340 Hz are easily heard. Try it.

With some practice, you can generate higher harmonics than the simplest, or fundamental, frequency. Figure 15.19b shows the standing-wave pattern for the next highest harmonic. This one has an antinode near the opening, as well as another antinode and two nodes within the tube. Because three-fourths of the wavelength is contained within the tube, the wavelengths of the interfering waves should be approximately four-thirds the length of the tube, or about 33 cm in a 25-cm tube. The frequency of the sound waves generated for this harmonic is, then, about 1020 Hz (340 m/s divided by 0.33 m). This frequency is three times the fundamental frequency and corresponds to a tone in the next octave.

Similar reasoning can be used to predict the frequencies of higher harmonics. We can also analyze the standing-wave patterns produced in a tube open at both ends or in one closed at both ends. The actual tone produced by a bottle or a musical instrument is usually a mixture of the various possible harmonics. The mix determines the quality or richness of the resulting sound waves.

Standing waves are one type of interference that is readily observable with sound waves. Sound waves traveling in the same direction can also interfere, producing either constructive or destructive interference, depending on the phase relationship between the interfering waves. “Dead spots” in auditoriums are sometimes produced by destructive interference. The acoustic design of concert halls is a complex art that must take interference into account.

Waves of sound produced by musicians’ tubes and strings may wash upon our ears. These sound waves are longitudinal waves involving regions of compression and decompression in the air. The air molecules must move back and forth along the axis of the wave to produce these changes. Sound waves can interfere, like other waves. The tones produced by wind instruments or soft-drink bottles involve standing waves of sound.

## 15.5 The Physics of Music

In sections 15.3 and 15.4, we discussed standing waves formed on a guitar string and in a pipe closed at one end. The length of the string or pipe determined the frequencies produced, and these frequencies are related to our perception of musical pitch. These ideas relating physics and music were known in antiquity.

There is a lot more to the physics of musical sounds than this, however. For example, why does a note played on a clarinet sound very different from the same note played on a trumpet or almost any other musical instrument? Why do you get different-sounding notes when you pluck a guitar string at different points? Why do certain combinations of notes (*chords*) sound better than others?

The concept of harmonic or frequency analysis plays a big role in understanding many of these issues. Determining the mix of frequencies present in a note played by a musical instrument can explain the quality of the tone produced. The relationships between the different frequencies or harmonics explains why different notes played together sound harmonious. Cultural factors also play a big role in our appreciation of music. Heavy metal may sound good to some, but others prefer Bach.

### What is harmonic analysis?

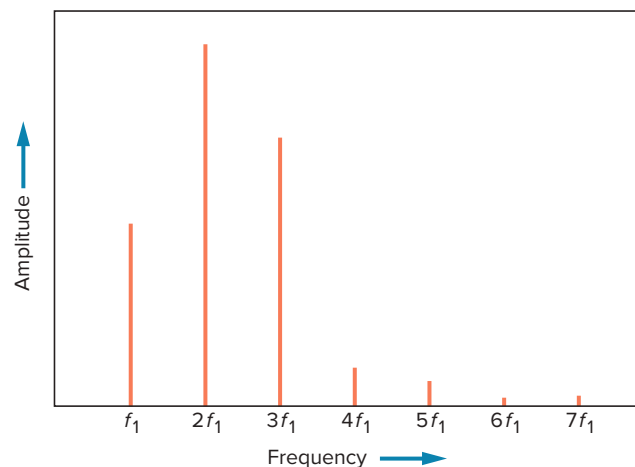
Recall the different standing waves we could generate on a guitar string, discussed in section 15.3. The first harmonic, or *fundamental*, had nodes at either end and an antinode at the middle of the string. The second harmonic had two lobes (the areas of oscillation between adjacent nodes) with an additional node at the center of the string. The third harmonic had three lobes with two nodes along the string in addition to the two at either end, and so on. Each of these harmonics has a different frequency, which are simple ratios of the fundamental.

If we simply pluck the string with a pick or finger somewhere along the string, we do not get just a single harmonic. Instead, there is a mix of different standing-wave modes or harmonics. If we can somehow determine the amplitude of each of the harmonics that make up the complex standing wave on the string, we perform a *frequency*, or **harmonic analysis**. The two terms mean the same thing.\*

In the case of a guitar string, the results of performing a harmonic analysis can be somewhat surprising. We usually pluck the string about a quarter of the way up from the *bridge*, where the string effectively terminates. The second harmonic ( $f_2 = 2f_1$ ) has an antinode at this position, so the second harmonic is strongly stimulated. The fundamental is not so strongly stimulated, because its antinode is at the middle of the string. For an acoustic guitar, the body of the guitar also determines which harmonics will be reinforced when the sound wave is generated. The resulting mix of harmonics might look like that pictured in figure 15.20.

Each peak in the graph in figure 15.20 represents a different harmonic. The height of the peak represents the amplitude of that harmonic. Such a graph can be easily generated with equipment and computer software available in most physics departments. Notice that the second and third harmonics are stronger than the fundamental. Interestingly, when we pluck the string in this manner, we still identify the pitch associated with this mix of harmonics as being that of the fundamental, not the second or third harmonics. Our ears and brains perform their own analysis and interpretation.

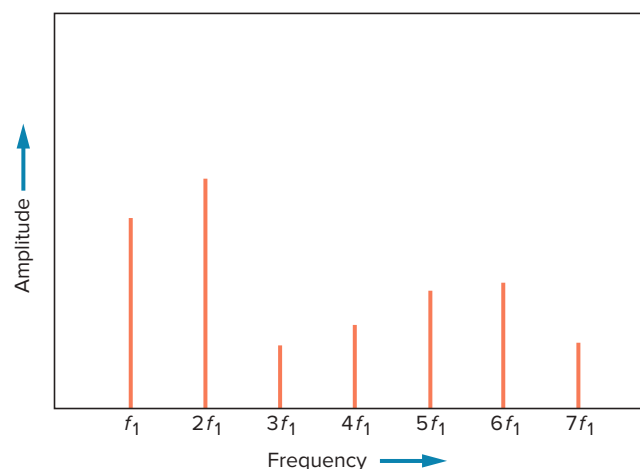
\*A frequency analysis of this sort is also called a Fourier analysis, after French mathematical physicist Jean-Baptiste Fourier (1768–1830), who developed the mathematical techniques involved.



**Figure 15.20** When a guitar string is plucked in the usual position, the second and third harmonics often dominate the harmonic spectrum.  $f_1$  is the frequency of the first harmonic or fundamental.

If we pluck the string much nearer to the bridge, we get a different mix of harmonics. The tone quality is also very different—the sound can be described as twangy. A frequency analysis would show a lot of higher harmonics (fig. 15.21), because these have antinodes nearer the bridge. The amplitude of the second and third harmonics may be much reduced. We still interpret the pitch of the note as being that of the fundamental, but the note sounds different. This twangy sound is often used in country and western music.

Different musical instruments generate tones that have very different harmonic mixes or graphs. This difference between instruments, which is related to the musical term *timbre*, is due to the mix of frequencies present in the notes produced. A trumpet usually produces a lot of higher harmonics in its frequency spectrum. It is these higher



**Figure 15.21** When a guitar string is plucked near the bridge, many higher harmonics are present in the harmonic spectrum. This results in a twangy sound.



harmonics that give it a “bright” or “brassy” sound. A flute, on the other hand, can be played such that the fundamental dominates the frequency spectrum with almost no higher harmonics being present. This yields the very “pure” tone that we associate with the flute. How the instrument is played can also have a large effect on the harmonics produced. If you have access to the equipment and software needed to generate a harmonic spectrum, it can be fun to test these ideas with different musical instruments (including your voice).

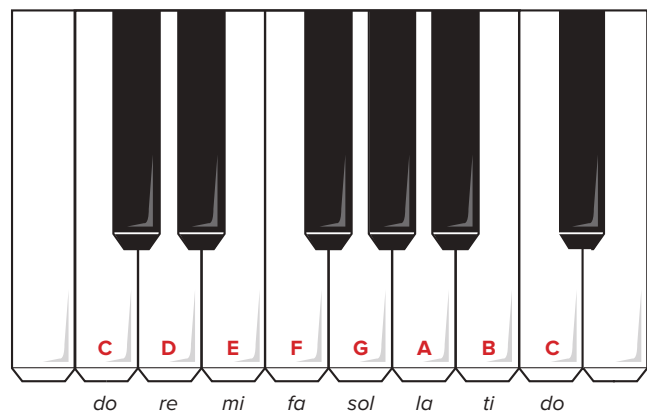
### How are musical intervals defined?

We noted in section 15.3 that doubling the frequency of a note (going from the first to the second harmonic) produces a change in pitch called an octave jump. The word *octave* has as its root the number eight. In Western music, we have traditionally used an eight-tone musical *scale*. When learning to sing, we identify the eight tones in the scale by the syllables *do, re, mi, fa, sol, la, ti, do* (fig. 15.22). The two *dos* at the ends are an octave apart.

If you play or sing two notes an octave apart, they sound very similar. In fact, we often have difficulty telling the difference between the notes. This is partly due to the fact that except for the fundamental of the lower note, two notes an octave apart have most of the same higher harmonics present when played on the same instrument. In identifying the note, our ears and brains use these higher harmonics.

When we play the third harmonic on a guitar, the frequency is 3 times the fundamental frequency, but only  $\frac{3}{2}$  times that of the second harmonic. We call the *musical interval* between the second and third harmonics a *fifth*. In singing, this is the difference between *do* and *sol*, the first and fifth notes in the eight-tone scale. It is the interval between the first pair of notes and the second pair of notes in the tune “Twinkle, Twinkle, Little Star.”

The fourth harmonic has a frequency four times the fundamental frequency and thus twice that of the second



**Figure 15.22** For a C-major scale beginning and ending on C, the eight notes of the scale are all played on the white keys of a piano.

## Example Box 15.4

### Sample Exercise: Determining Frequencies for Different Intervals

A C-major scale begins with *do* on middle C having a frequency of approximately 264 Hz. Assuming they have been tuned to the perfect ratios (just tuning) for the intervals in question, what should the frequency be for the following notes?

- sol* (G)
- fa* (F)
- do* at the top of the scale (high C)

a. *Sol* is a fifth above *do*, with a ratio of  $\frac{3}{2}$ .

$$f = \frac{3}{2} (264 \text{ Hz}) = \mathbf{396 \text{ Hz}}$$

b. *Fa* is a fourth above *do*, with a ratio of  $\frac{4}{3}$ .

$$f = \frac{4}{3} (264 \text{ Hz}) = \mathbf{352 \text{ Hz}}$$

c. From *do* to the next higher *do* is an octave, which doubles the frequency.

$$f = 2 (264 \text{ Hz}) = \mathbf{528 \text{ Hz}}$$

harmonic. It is an octave above the second harmonic and two octaves above the fundamental. The third and fourth harmonics have the frequency ratio  $\frac{4}{3}$  and this is the interval between *sol* and the *do* at the top of the scale. This interval is called a *fourth*, which is also the interval between *do* and *fa*, the first and fourth notes on the scale. (See example box 15.4.)

The fifth harmonic has a frequency 5 times that of the fundamental, but only  $\frac{5}{4}$  times that of the fourth harmonic. The musical interval between the fourth and fifth harmonics is called a *major third*. In singing, it is the interval between *do* and *mi*, the first and third notes in the scale. Other intervals can be defined in a similar manner.

The other three notes in the scale can also be defined as simple frequency ratios of other notes in the scale. (See synthesis problem 5.) *Ti* is a musical third above *sol* ( $\frac{5}{4}$ ), *re* is a musical fourth below *sol* ( $\frac{3}{4}$ ), and *la* is a musical third above *fa* ( $\frac{5}{4}$ ). All of the notes in the scale can therefore be related to length ratios of a stretched string on an instrument such as a guitar. The role of these length ratios in music was recognized by Greek mathematician Pythagoras as early as 530 B.C., although Pythagoras limited himself to the octave and the fifth in building his scale.

There is a problem, however, with tuning a guitar, or particularly a piano, in this way. Although the instrument may sound great in one key—that for which it was tuned—it will sound terrible in others. Thus, if we tune the piano so that the ratios are all correct (called **just tuning**) when we start our scale on middle C ( $f = 264 \text{ Hz}$  for just tuning), the ratios will not be correct if we start our scale on the next note up (called D). So unless you want to play your piano in just one

Table 15.1

Frequencies and Ratios for Different Tuning Methods

Equal Temperament			Just Tuning			
Note	$f$ (Hz)	Ratios	Note	$f$ (Hz)	Frequency Ratios	
C	261.6	1.05946	C ( <i>do</i> )	264.0		
C# ( <i>D<sup>b</sup></i> )	277.2	1.05946	D ( <i>re</i> )	297.0		$\frac{9}{8}$
D	293.7	1.05946	E ( <i>mi</i> )	330.0	$\frac{3}{2}$	$\frac{4}{3}$
D# ( <i>E<sup>b</sup></i> )	311.1	1.05946	F ( <i>fa</i> )	352.0		$\frac{5}{4}$
E	329.6	1.05946	G ( <i>sol</i> )	396.0		$\frac{6}{5}$
F	349.2	1.05946	A ( <i>la</i> )	440.0	$\frac{5}{4}$	$\frac{4}{3}$
F# ( <i>G<sup>b</sup></i> )	370.0	1.05946	B ( <i>ti</i> )	495.0		$\frac{6}{5}$
G	392.0	1.05946	C ( <i>do</i> )	528.0		
G# ( <i>A<sup>b</sup></i> )	415.3	1.05946				
A	440.0	1.05946				
A# ( <i>B<sup>b</sup></i> )	466.2	1.05946				
B	493.9	1.05946				
C	523.3	1.05946				

key, you need to compromise on the ratios between the notes. The most common compromise is called **equally tempered** tuning. In this method of tuning, the ratios are all approximately correct, but not perfect, for any key. The ratios between adjacent half steps on the scale are all identical, however, so the scales sound correct regardless of where you start. (See synthesis problem 4.)

Table 15.1 shows the frequencies for both equally tempered tuning and just tuning for a C scale. Both are based on the standard 440-Hz frequency for A above middle C. The equally tempered scale shows the sharps (#) and flats (*b*), which together with the notes of the major scale make up a scale consisting of 12 equal-ratio half steps. The frequency ratio of each note to that of the preceding half step is 1.05946, which is the twelfth root of two ( $\sqrt[12]{2}$ ). Multiplied by itself 12 times it equals 2, which is the appropriate ratio for a full octave. We have not shown the frequencies for the sharps and flats for just tuning. In some versions of just tuning, the flat can have a different frequency than the sharp of the note just below—for example, A-flat (*A<sup>b</sup>*) might have a different frequency than G-sharp (*G#*).

Historically, many physicists and mathematicians have been involved in debates over the ideal tuning method. Pythagoras, Ptolemy, Kepler, and Galileo all contributed ideas. Claudius Ptolemy, who is primarily known for his geocentric model of the solar system, was instrumental in the introduction of just tuning. Galileo's father, Vincenzo Galilei, was a music theorist. Galileo himself was actively involved in these issues at the time that equal temperament was being proposed and debated. Equal temperament now dominates for tuning pianos, and we have become used to the compromises involved.

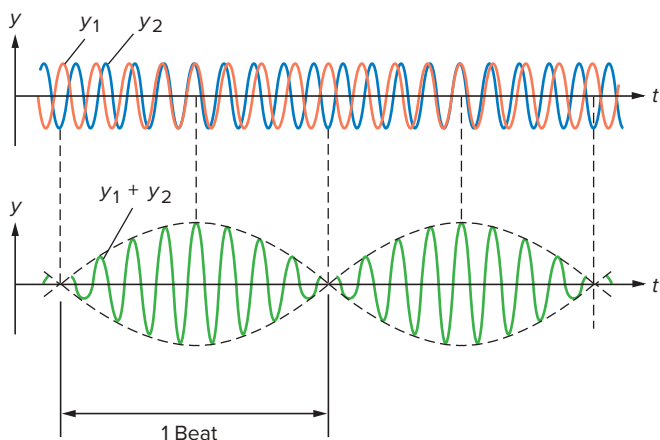
### Why do some combinations of notes sound harmonious?

Why do some notes sound pleasing to us when played together, while others do not? The issue is partly cultural, but there is also a physical basis for what we call *harmony*. Not surprisingly, it can be *partly* explained by the harmonics present in the notes.

For example, if we play the notes *do* and *sol* together, the sound is pleasing to most people. These two notes sound like they belong together, even for people from different cultures. Remember that when you play or sing any note, the resulting sound will usually contain higher harmonics of the fundamental frequency. Because of the simple frequency ratio between these two notes a fifth apart, many of these higher harmonics will be the same. The third harmonic for *do*, for example, is identical to the second harmonic for *sol*. They reinforce one another in the higher harmonics.

A group of notes is called a chord. If we add two more notes to the two notes above, yielding the chord *do, mi, sol, do* (the second *do* an octave higher), the sound is even more harmonious. Once again, there is strong overlap of the higher harmonics in these notes. The same is true for many other simple chords. On a piano or guitar, we make strong use of chords such as these to build our musical structures. In a band or chorus, different instruments or voices provide the notes in the chords.

Some notes do not sound good together, at least to people accustomed to classical music. If we play a *do* and a *re* together, for example, the sound is *dissonant*. Although a lack of strong overlap in higher harmonics can partly explain the harsh sound that results, another physical phenomenon called *beats* is at work.



**Figure 15.23** The two waves with slightly different frequency in the top drawing interfere to produce the beats shown in the lower drawing. The two waves come in and out of phase as time progresses.

When two waves of different frequencies are combined, they interfere. Because their frequencies differ, they come in and out of phase with one another as time progresses. When they are in phase, the combined wave has a large amplitude. When they are out of phase, the amplitude is much smaller. This fluctuation in amplitude of the combined wave is called **beat**. (See fig. 15.23.)

The frequency of the variation in amplitude (called the *beat frequency*) is equal to the difference in frequency of the two waves. If the two notes are very close in frequency, the beat frequency is slow enough to be heard as a variation in amplitude. In other words, you can hear the sound getting louder and softer in a repetitive wah-wah pattern. This effect can be useful in tuning one instrument to another. When the beats become very slow or disappear altogether, the two instruments are in tune. (Beats are also very useful in tuning the double strings on a mandolin or 12-string guitar.)

When the two notes differ by a full step on the scale, as with *do* and *re*, the beat frequency is rapid enough that we hear a harsh buzz. This buzz produces what, for many of us, is an unpleasant sound. In modern music, however, this dissonant sound is sometimes used to produce desired effects.

As the difference in frequency becomes even larger, the beat frequency can sometimes be heard as a separate tone. The pitch of this tone corresponds to the beat frequency. For example, if we play *do* and *sol* together, the beat frequency is

$$\frac{3}{2}f - f = \frac{1}{2}f$$

where  $f$  is the frequency of the lower note, *do*. A note with a frequency one-half that of *do* is an octave below *do*, so it fits nicely within a chord containing *do* and *sol*. Thus, beats can help to explain the richness of the harmony we get when we play major chords.

There is much more to the physics of music than these basic ideas. The acoustics of a good concert hall, for example, involves wave interference, reflection, sound absorption, and many other effects. A good musician develops a discriminating “ear” and can detect and identify musical intervals and chords much more readily than an untrained person, but most of us have had enough exposure to music to appreciate the effects produced. Playing around with a guitar or piano can demonstrate many of the ideas we have just discussed.

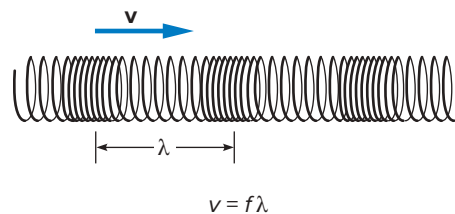
The frequency of a sound wave is associated with its musical pitch. When we play a note on a musical instrument, the sound will contain the fundamental frequency, as well as higher harmonics with frequencies that are integer multiples of the fundamental. A harmonic analysis of the sound determines the amplitude of each of the frequencies present. Harmonics play an important role in defining the musical intervals in the scale used in Western music. Different combinations of these notes sound harmonious when the higher harmonics in the notes reinforce one another, as they do in a major chord. Two notes of different frequency interfere to produce a beat frequency equal to the difference in frequency between the two notes. The beat frequency also plays a role in whether the combination of two notes will be pleasing or dissonant.

## Summary

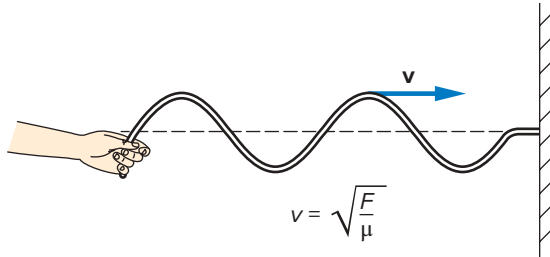
A wave is a moving disturbance that propagates energy through a medium. Water waves, waves on a Slinky, waves on a string or rope, and sound waves all share features such as reflection and interference, which are common to any wave motion. These waves differ in the type of medium involved, the nature of the disturbance that is propagating, and the wave speed. Standing waves and harmonic analysis play an important role in the physics of music.

**1 Wave pulses and periodic waves.** Basic features of wave motion can be demonstrated on a Slinky, including single pulses as well as continuous waves. For longitudinal waves, the

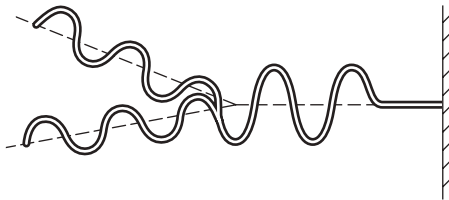
disturbance is along the line of travel. For transverse waves, it is perpendicular to the direction of travel. The wave speed is equal to the frequency times the wavelength of the wave.



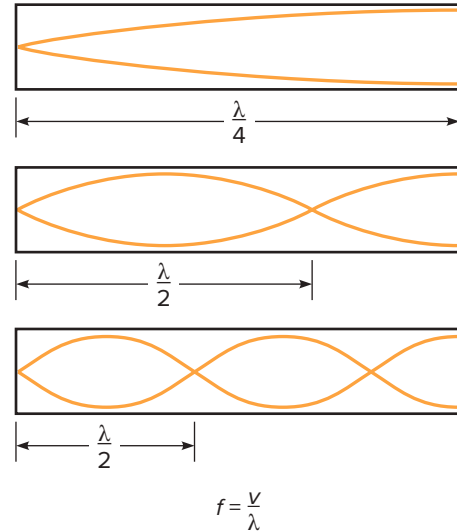
**2 Waves on a rope.** Transverse waves can be generated on a rope or string. If the end of the rope is moved in simple harmonic motion, the wave has a sinusoidal shape. The wave speed depends on the tension in the rope and the mass per unit of length ( $\mu = m/L$ ) of the rope.



**3 Interference and standing waves.** When two or more waves combine, the disturbances add to form a new wave. The interference can be constructive, producing a larger amplitude if the waves are in phase, or it can be destructive, producing a smaller or zero amplitude if they are out of phase. Two waves traveling in opposite directions produce a standing wave.



**4 Sound waves.** Sound waves are longitudinal waves involving the propagation of pressure variations through air or other media. The speed of sound is about 340 m/s in room-temperature air. Standing sound waves can be formed in pipes and soft-drink bottles. The length of the pipe determines the wavelength and the frequency of the various harmonics.



**5 The physics of music.** Harmonic analysis shows that musical notes played by most instruments contain a mix of higher harmonics along with the fundamental frequency. Musical scales and intervals are based on the ratios between these higher harmonics. Combinations of notes sound harmonious when the higher harmonics overlap. When two notes are too close in pitch, beats can produce a dissonant buzz.



The study hints in Connect give a concise summary of the ideas presented in this chapter. Try reviewing them before your next exam; it should help remind you of the important points.

## Key Terms

Wave pulse, 309  
 Periodic wave, 312  
 Wavelength, 312  
 Harmonic wave, 313

Interference, 315  
 Principle of superposition, 316  
 Node, 317  
 Antinode, 317

Standing wave, 317  
 Pitch, 317  
 Sound wave, 319  
 Doppler effect, 321

Harmonic analysis, 323  
 Just tuning, 324  
 Equally tempered, 325  
 Beat, 326

## Conceptual Questions

\* = more open-ended questions, requiring lengthier responses, suitable for group discussion

Q = sample responses are available in appendix D

Q = sample responses are available in Connect

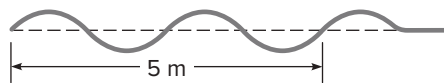
- Q1. A wave pulse is transmitted down a Slinky, but the Slinky itself does not change position. Does a transfer of energy take place in this process? Explain.
- Q2. Waves are traveling in an eastward direction on a lake. Is the water in the lake necessarily moving in that direction? Explain.

- Q3. If the magnet in the buoy described in everyday phenomenon box 15.1 is tethered to the ocean floor and does not move up and down, how does it take advantage of the wave motion to generate power? Explain.
- Q4. What does *rectification* mean, and why is it needed in a wave-power system? Explain. (See everyday phenomenon box 15.1.)
- Q5. A slowly moving engine bumps into a string of coupled railroad cars standing on a siding. A wave pulse is transmitted down the string of cars as each one bumps into the next one. Is this wave transverse or longitudinal? Explain.

- Q6.** A wave can be propagated on a blanket by holding adjacent corners in your hands and moving the end of the blanket up and down. Is this wave transverse or longitudinal? Explain.
- Q7. If you increase the frequency with which you are moving the end of a Slinky back and forth, does the wavelength of the wave on the Slinky increase or decrease? Explain.
- Q8. If you increase the speed of a wave on a Slinky by increasing the tension but keep the same frequency of back-and-forth motion, does the wavelength increase or decrease? Explain.
- Q9.** Is it possible to produce a transverse wave on a Slinky? Explain.
- \*Q10. At sporting events, the crowd sometimes generates a “wave” that propagates around the stadium. Is this wave transverse or longitudinal? What causes the wave to travel through the crowd? Explain.
- \*Q11. Is it possible to produce a longitudinal wave on a rope? Explain.
- Q12.** Suppose we double the mass per unit of length of a rope by twining two ropes together. What effect does this have on the speed of a wave on this rope? Explain.
- Q13. What force causes individual segments of a rope to accelerate when a transverse pulse travels down the rope? Explain.
- Q14. Why is it easier to observe transverse waves on a heavy rope than on a light string? Explain.
- Q15.** Suppose we increase the tension in a rope, keeping the frequency of oscillation of the end of the rope the same. What effect does this have on the wavelength of the wave produced? Explain.
- Q16. Is it possible for two waves traveling in the same direction to produce a wave (when they interfere) that has a smaller height (amplitude) than either of the individual waves? Explain.
- Q17. Two ropes are joined smoothly to form a single rope, which is attached to a wall. If the ends of the two ropes are moved up and down in phase, but one rope is half a wavelength longer than the other to the point where they join, will the interference of the two waves when they join be constructive or destructive? Explain.
- \***Q18.** When two waves on separate ropes reach the spliced junction out of phase with one another, they interfere destructively, producing no wave beyond the splice. What happens then to the energy carried by the waves? Will there be reflected waves? Explain.
- Q19. We can form standing waves on a rope attached to a wall by moving the opposite end of the rope up and down at an appropriate frequency. Where does the second wave come from that interferes with the initial wave to form the standing wave? Explain.
- Q20. A standing wave is produced on a string fixed at both ends, so that there is a node in the middle, as well as at each end. Will the frequency of this wave be greater than, equal to, or less than the frequency of the fundamental frequency, which has nodes only at the ends? Explain.
- Q21.** Is the distance between the antinodes of a standing wave equal to the wavelength of the two waves that interfere to form the standing wave? Explain.
- Q22. If we increase the tension of a guitar string, what effect does this have on the frequency and wavelength of the fundamental standing wave formed on that string? Explain.
- Q23. If we wrap a second wire around a guitar string to increase its mass, what effect does this have on the frequency and wavelength of the fundamental standing wave formed on that string? Explain.
- Q24.** Why is it much easier to produce longitudinal waves traveling in air than it is to produce transverse waves? Explain.
- Q25. Is it possible for sound to travel through a steel bar? Explain.
- Q26. Suppose we increase the temperature of the air through which a sound wave is traveling.
- What effect does this have on the speed of the sound wave? Explain.
  - For a given frequency, what effect does increasing the temperature have on the wavelength of the sound wave? Explain.
- Q27.** If the temperature in an organ pipe increases above room temperature, thereby increasing the speed of sound waves in the pipe but not affecting the length of the pipe significantly, what effect does this have on the frequency of the standing waves produced by this pipe? Explain.
- Q28. Is the wavelength of the fundamental standing wave in a tube open at both ends greater than, equal to, or less than the wavelength for the fundamental wave in a tube open at just one end? Explain.
- Q29. A band playing on a flat-bed truck is approaching you rapidly near the end of a parade. Will you hear the same pitch for the various instruments as someone down the street who has already been passed by the truck? Explain. (See everyday phenomenon box 15.2.)
- Q30.** When the sound source is moving relative to the listener, does the speed, frequency, and/or wavelength of the sound wave you detect change? Explain. (See everyday phenomenon box 15.2.)
- Q31. Is it possible for sound waves to travel through a vacuum? Explain.
- Q32. When you pluck a guitar string, are you likely to get a sound wave containing just a single frequency? Explain.
- \***Q33.** Why is the second harmonic of a plucked guitar string likely to be stronger than the first harmonic, or fundamental, when the string is plucked in the usual position? Explain.
- Q34. What are we measuring when we perform a harmonic analysis of a sound wave? Explain.
- Q35. How is the musical interval that we call a fifth related to the third harmonic of a plucked string? Explain.
- Q36.** Why do two notes an octave apart sound so much alike? Explain.
- \*Q37. Frequency and pitch are related, but are they the same thing? When we identify a note as having a certain pitch, is it likely to contain a single frequency? How does perceived pitch for someone who cannot carry a tune differ from that for a trained musician? Discuss.
- Q38. Two notes close together on the scale, such as *do* and *re*, produce a buzz when played together. What is the source of this buzz? Explain.

## Exercises

- E1. Suppose that water waves coming into a dock have a velocity of 2.1 m/s and a wavelength of 5.6 m. With what frequency do these waves meet the dock?
- E2. Suppose that water waves have a wavelength of 3.8 m and a period of 1.7 s. What is the velocity of these waves?
- E3. A longitudinal wave on a Slinky has a frequency of 6 Hz and a speed of 1.5 m/s. What is the wavelength of this wave?
- E4. A wave on a rope is shown in the diagram.
- What is the wavelength of this wave?
  - If the frequency of the wave is 4 Hz, what is the wave speed?



**E4 Diagram**

- What is the frequency of the wave?
  - What is the wavelength of the wave?
- E6. Suppose that a guitar string has a length of 0.64 m, a mass of 4.3 g (0.0043 kg), and a tension of 75.6 N.
- What is the mass per unit of length of this string?
  - What is the speed of a wave on this string?
- E7. A string with a length of 0.75 m is fixed at both ends.
- What is the longest possible wavelength for the traveling waves that can interfere to form a standing wave on this string?
  - If waves travel with a speed of 130 m/s on this string, what is the frequency associated with this longest wavelength?
- E8. Suppose that the string in exercise 7 is plucked so that there are five nodes along the string in addition to those at either end. What is the wavelength of the interfering waves for this mode?
- E9. Sound waves have a speed of 340 m/s in room-temperature air. What is the wavelength of the sound waves for the musical tone concert A, which has a frequency of 440 Hz?
- E10. What is the frequency of a sound wave with a wavelength of 0.56 m traveling in room-temperature air ( $v = 340$  m/s)?
- E11. An organ pipe closed at one end and open at the other has a length of 0.6 m.
- What is the longest possible wavelength for the interfering sound waves that can form a standing wave in this pipe?
  - What is the frequency associated with this standing wave if the speed of sound is 340 m/s?
- E12. Suppose we start a major scale on concert A, which is defined to have a frequency of 440 Hz. If we call this frequency *do*, what is the ideal-ratio frequency (in other words, using just tuning) of the following?
- re*
  - sol*
- E13. If *fa* on a given scale has a frequency of 348 Hz, what is the ideal-ratio frequency (using just tuning) of *do* at the bottom of this scale?
- E14. In just tuning, the ratio for a major third is  $\frac{5}{4}$ . In equally tempered tuning, the ratio is 1.260. If we start a scale on a frequency of 880 Hz for *do*, what is the difference in frequency for *mi* (a major third above *do*) on an equally tempered piano and a justly tuned piano?
- E15. If *do* has a frequency of 265 Hz and *re* a frequency of 334 Hz, what is the beat frequency produced when these two notes are played together?
- E16. If one guitar string is tuned to a frequency of 352 Hz, and a string on another guitar produces 7 beats per second when played together with the first string, what are the possible frequencies of the second string?
- E17. What is the beat frequency that results when a 450-Hz note is played with a 360-Hz note? If this beat frequency is heard as a musical tone, how is this tone related to the original two notes? What are the intervals?

## Synthesis Problems

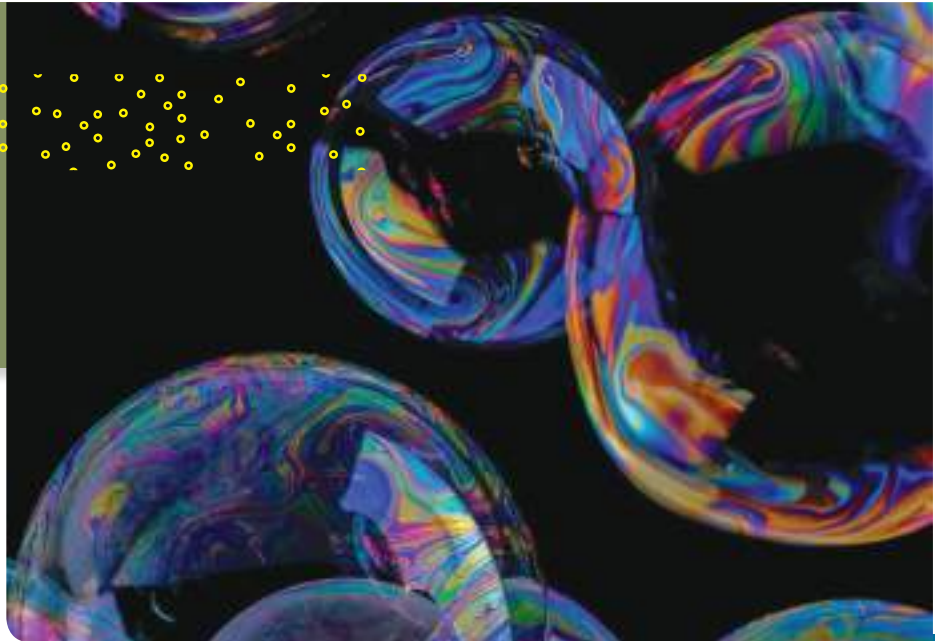
- SP1. A certain rope has a length of 12 m and a mass of 3.2 kg. It is fixed at one end and held taut at the other with a tension of 48.6 N. The end of the rope is moved up and down with a frequency of 4.5 Hz.
- What is the mass per unit of length of the rope?
  - What is the speed of waves on this rope?
  - What is the wavelength of waves on this rope having a frequency of 4.5 Hz?
  - How many complete cycles of these waves will fit on the rope?
  - How long does it take for the leading edge of the waves to reach the other end of the rope and start coming back?
- SP2. A guitar string has an overall length of 1.25 m and a total mass of 1.0 g (0.001 kg) before it is strung on the guitar. Once on the guitar, however, there is a distance of 69 cm between its fixed end points. It is tightened to a tension of 74 N.
- What is the mass per unit of length of this string?
  - What is the wave speed for waves on the tightened string?
  - What is the wavelength of the traveling waves that interfere to form the fundamental standing wave (nodes just at either end) for this string?
  - What is the frequency of the fundamental wave?
  - What are the wavelength and frequency of the next harmonic (with a node in the middle of the string)?

- SP3. A pipe that is open at both ends will form standing waves, if properly excited, with antinodes near both ends of the pipe. Suppose we have an open pipe 60 cm in length.
- Sketch the standing-wave pattern for the fundamental standing wave for this pipe. (There will be a node in the middle, and antinodes at either end.)
  - What is the wavelength of the sound waves that interfere to form the fundamental wave?
  - If the speed of sound in air is 340 m/s, what is the frequency of this sound wave?
  - If the air temperature increases so that the speed of sound is now 358 m/s, by how much does the frequency change?
  - Sketch the standing-wave pattern and find the wavelength and frequency for the next harmonic in this pipe.
- SP4. For standard tuning, concert A is defined to have a frequency of 440 Hz. On a piano, A is five white keys above C, but 9 half steps above C counting both the white and black keys. (See fig. 15.22.) A full octave consists of 12 half steps (semitones). In equally tempered tuning, each half step has the ratio of 1.0595 above the preceding step. (This ratio is the twelfth root of 2.0.)
- What is the frequency of A-flat, one half step below A for equal temperament?
  - Working down, find the frequency of each succeeding half step until you get down to C. (Carry your computations to four figures, to avoid rounding errors. For each half step, divide by 1.0595.)
  - In just tuning, middle C has a frequency of 264 Hz. How does your result in part b compare to this value?
  - Working up, find the frequency of C above concert A in equal temperament. Is this frequency twice that obtained in part b for middle C?
- SP5. Using the procedure outlined in section 15.5, where the ideal ratios for a justly tuned scale are described, find the frequencies for all of the white keys between middle C (264 Hz) and the C above middle C (a C-major scale). If you have worked synthesis problem 4, compare the frequencies for just tuning to those for equal temperament.
- G (*sol*) is a fifth above C ( $\frac{3}{2}$ ).
  - F (*fa*) is a fourth above C ( $\frac{4}{3}$ ).
  - E (*mi*) is a major third above C ( $\frac{5}{4}$ ).
  - B (*ti*) is a major third above G (*sol*).
  - D (*re*) is a fourth below G (*sol*).
  - A (*la*) is a major third above F (*fa*).

## Home Experiments and Observations

- HE1. If you have access to a Slinky, either through a younger brother or sister or through your local physics lab, try producing some of the effects described in section 15.1.
- Can you estimate the speed of single longitudinal pulses produced on the Slinky?
  - How does this speed change as the Slinky is stretched?
  - Does a transverse pulse travel with the same speed as a longitudinal pulse?
  - Can you produce a continuous longitudinal wave on the Slinky?
- HE2. Water waves can be created easily by moving your hand in a bathtub or other small pool of water. The wave crests can be directly observed.
- Try moving your hand at different frequencies. How does the wavelength vary with frequency?
  - Can you estimate the speed of a wave pulse?
  - By using both hands, two waves can be created that come together and interfere. If you move your hands in unison, you should observe constructive interference along the center line between the two waves. What effect does this have on the wave that you observe along the center line?
  - Can you produce destructive interference by moving your hands so that one is going up while the other is going down? Describe what happens when you attempt this.
- HE3. Empty a soft-drink bottle and practice blowing over the opening, as described in section 15.4, until you are able to produce a consistent tone.
- How does the pitch of this tone vary if you put water in the bottle? What is the relationship of the pitch when the bottle is half-filled to that when it is empty?
  - Try producing higher harmonics by blowing harder and reducing the opening in your lips. (This is easy for a flute player but takes some practice for other mortals.)
- How is the pitch of a higher harmonic related to the pitch of the fundamental?
- By filling eight bottles to different levels, you can produce all the notes of a one-octave scale. Gather a few friends and try playing “Three Blind Mice” or some other simple tune.
- HE4. If you have access to a guitar, try generating some of the higher harmonics using the technique discussed in section 15.3.
- How many higher harmonics can you produce? Do the locations of dots on the neck of the guitar provide guidance on where to place your finger?
  - Try plucking the guitar in the usual fashion, as well as much nearer the bridge. Can you hear higher harmonics in the tone produced? How does the tone differ in these two situations?
  - If you have access to harmonic analysis equipment in your physics lab, compare the harmonic spectrum produced by plucking a string in the two positions described in part b.
- HE5. If you have never played a piano, a lot can be learned by sitting down at a keyboard and trying a few scales and intervals.
- Play a C-major scale, as illustrated in figure 15.22.
  - Play a D-major scale, beginning and ending on D. Which black keys did you have to use to make the scale sound right?
  - Play a G-major scale beginning and ending on G. Which black keys did you use?
  - Play a major chord (*do, mi, sol, do*) starting on the different notes listed in parts a, b, and c, as well as others. Which keys on the piano did you use?
  - Play C in several different octaves. Do these notes all sound similar? Can you hear different harmonics?

# CHAPTER 16



Jim DeLillo/Alamy Stock Photo

## Light Waves and Color

### Chapter Overview

What is light, what are its properties, and how can we explain the rich array of color phenomena that are a part of our everyday experience? Starting from the recognition that light is an electromagnetic wave, we explore its behavior, including the properties of absorption, selective reflection, interference, diffraction, and polarization. Our perception of color is affected by all of these processes.

### Chapter Outline

- 1 Electromagnetic waves.** What are electromagnetic waves, and how are they produced? What is light? In what ways are radio waves and light waves alike, and how do they differ?
- 2 Wavelength and color.** How is color related to wavelength? How do we perceive color? How do the processes of selective reflection, absorption, and scattering determine the colors we see? Why is the sky blue?
- 3 Interference of light waves.** How did Young's double-slit interference experiment demonstrate that light is a wave? What is thin-film interference? How can we explain the interference colors we see on oil slicks and other thin films?
- 4 Diffraction and gratings.** What is diffraction? How does diffraction limit our ability to see fine detail? What are diffraction gratings, and how are they used to measure wavelengths?
- 5 Polarized light.** What is polarized light? How is polarization produced, and how can we tell whether light is polarized? What is birefringence, and how can it produce color phenomena?

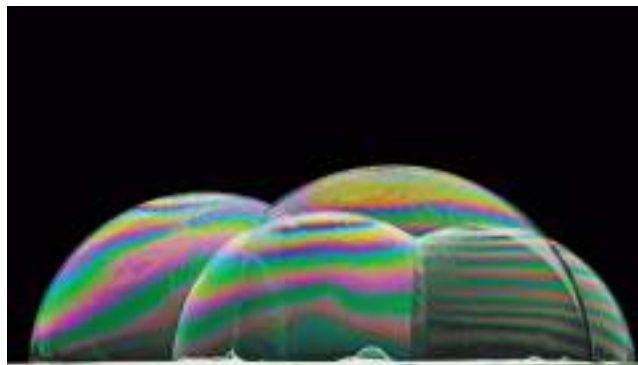


**H**ave you ever wondered why our world appears so colorful to us? Light is certainly involved in what we see, but what is light? Why do soap films appear so multicolored and why is the sky blue? All of these phenomena are related to the wave nature of light.

All of us have played with soap bubbles at some point in our lives. You may have also been fascinated with soap films in the metal loop that is often used to create bubbles. If you hold the loop still, the film will settle into a pattern of colored bands (fig. 16.1). As you watch these bands, the colors change until finally the film breaks.

How do we explain this? The colorful behavior of soap films and bubbles, as well as many other phenomena involving color, involves interference of light waves. Many ideas regarding waves, including interference, were introduced in chapter 15, but light waves provide some surprising and interesting examples of these ideas.

Light is an electromagnetic wave, so we will have to explore what that means. Light waves can be reflected, refracted, polarized, scattered, and absorbed. They also can interfere with one another to produce some striking effects. Reflection and refraction can be described in terms of ray optics, as we will see in chapter 17. Ray optics describes the behavior of lenses and mirrors, which are used to make many optical instruments, such as microscopes and telescopes.



**Figure 16.1** Soap bubbles viewed in reflected light display striking interference colors. *ffaber53/iStock/Getty Images*

As we discussed briefly in the introduction of unit 4, light has both wave and particle-like properties. This chapter will focus on aspects of light that are directly dependent on the wave properties of light. Wave optics describes interference and diffraction phenomena as well as properties such as absorption, scattering, and polarization. All of these phenomena are involved in producing the colors we see.

## 16.1 Electromagnetic Waves

What do light, radio waves, microwaves, and X-rays have in common? They are all forms of electromagnetic waves. Together, they represent an enormous range of phenomena that have become extremely important in our modern technological world.

The prediction of the existence of electromagnetic waves and a description of their nature were first published by James Clerk Maxwell in 1865. Maxwell was an enormously talented theoretical physicist who made important contributions in many areas of physics, including electromagnetism, thermodynamics, the kinetic theory of gases, color vision, and astronomy. He is best known, however, for his treatise on electric and magnetic fields, which we have already mentioned. His description of electromagnetic waves, with a prediction of their speed, was just one feature of this work.

### What is an electromagnetic wave?

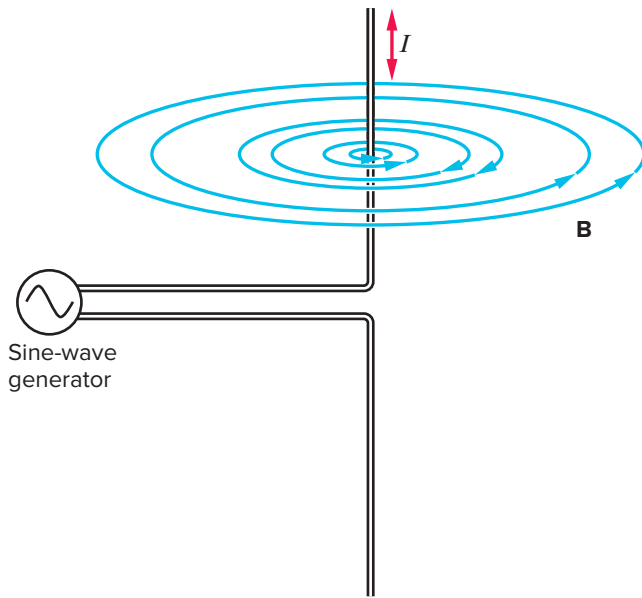
To understand **electromagnetic waves**, we need to review the concepts of electric field and magnetic field. Both fields can be produced by charged particles. *Motion* of the charge is necessary to generate a magnetic field, but an electric field is present regardless of whether the charge is moving. These fields are a property of the space around the charges

and are useful for predicting the forces on other charges, as discussed in chapters 12 and 14.

Suppose that charge is flowing up and down in two lengths of wire connected to an alternating-current source, as in figure 16.2. If the current reverses direction rapidly enough, an alternating current will flow in this arrangement, even though it appears to be an open circuit. Charge of one sign will begin to accumulate in the wires, but before the accumulated charge gets too large, the current reverses, the charge flows back, and the opposite-sign charge begins to build. We thus have both a changing amount of charge and a changing electric current in the wires.

The magnetic fields generated by this arrangement can be depicted by circular field lines centered on the wires, as shown. This field, however, is constantly changing in both magnitude and direction as the current changes. From Faraday's law, Maxwell knew that a changing magnetic field would generate a voltage in a circuit whose plane is perpendicular to the magnetic field lines. A voltage implies an electric field, and even in the absence of a circuit, a changing magnetic field will generate an electric field at any point in space where the magnetic field is changing.

Thus, we expect a changing electric field to be generated by the changing magnetic field, according to Faraday's law. Maxwell saw a symmetry in the behavior of electric and magnetic fields: A changing electric field also generates a



**Figure 16.2** A rapidly alternating electric current in the wires generates a magnetic field,  $\mathbf{B}$ , whose direction and magnitude change with time.

magnetic field. Maxwell predicted this phenomenon in his equations describing the behavior of electric and magnetic fields. Experimental measurements confirmed its existence.

Maxwell realized that a wave involving these fields could propagate through space. A changing magnetic field produces a changing electric field, which in turn produces a changing magnetic field, and so on. In a vacuum, the process can go on indefinitely and affect charged particles at much greater distances from the source than would be possible with static fields generated by nonchanging currents or charges. This is how an electromagnetic wave is produced. (In a more general sense, any accelerated charge creates an electromagnetic wave.) The wires in figure 16.2 serve as a transmitting antenna for the waves. A second antenna can be used to detect the waves.

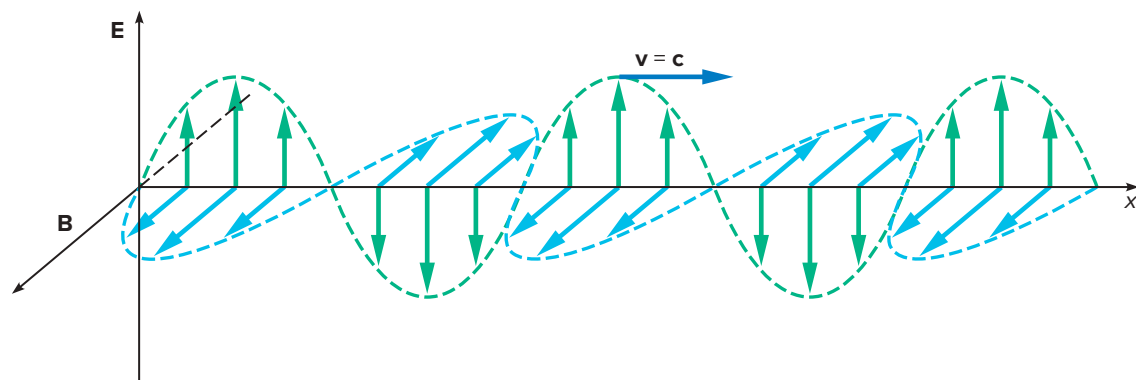
Although Maxwell predicted the existence of such waves in 1865, the first experiment to produce and detect them with electric circuits was performed by Heinrich Hertz (1857–1894) in 1888. Hertz's original antennas were circular loops of wire instead of straight wires, but he also used straight wires in later work. He could detect a wave produced by the source circuit with another circuit at a considerable distance from the source. Hertz discovered radio waves by doing these experiments.

Figure 16.3 presents a closer look at the nature of simple electromagnetic waves. If the magnetic field,  $\mathbf{B}$ , is in the horizontal plane, as in figure 16.2, the electric field,  $\mathbf{E}$ , generated by the changing magnetic field is in the vertical direction. These two fields are perpendicular to each other, and they are perpendicular to the direction of travel away from the source antenna. Electromagnetic waves are therefore transverse waves. The magnitudes of the electric and magnetic fields are pictured here as varying sinusoidally—and in phase with each other—but more complex patterns are also possible.

Like the other types of waves we have studied, the sinusoidal wave pattern moves. Figure 16.3 shows the field magnitudes and directions at a single instant in time and along only one line in space. The same kind of variation occurs in all directions perpendicular to the antenna. As the sinusoidal pattern moves, the field values at any point in space alternately increase and decrease. As the fields go through zero, they change direction and begin to increase in the opposite direction. These coordinated changes of the electric and magnetic fields make up the electromagnetic wave.

### What is the speed of electromagnetic waves?

In predicting the existence of electromagnetic waves from his theory of electric and magnetic fields, Maxwell could also predict their speed. The speed of these waves in a vacuum can be computed from just two constants, the Coulomb constant  $k$  in Coulomb's law and the magnetic force constant  $k'$  in Ampère's expression for the force between two current-carrying wires. Maxwell's theory predicted that the wave speed should be equal to the square root of the ratio of these



**Figure 16.3** The time-varying electric ( $\mathbf{E}$ ) and magnetic ( $\mathbf{B}$ ) fields in an electromagnetic wave are in directions perpendicular to each other, as well as to the wave speed.

two numbers ( $v = \sqrt{k/k'}$ ), which yields a value of  $3 \times 10^8$  m/s, or 300 million meters per second.

The striking fact about this value, other than its incredible size, is that it corresponded with the known value of the speed of light. The speed of light had been accurately measured by different scientists not too many years before Maxwell's work. This coincidence led Maxwell to suggest that light itself was an electromagnetic wave—the first direct connection between the fields of optics and electromagnetism.

Measuring the speed of light was no easy task in Maxwell's day. Galileo was one of the first to attempt a measurement 250 years earlier. He sent an assistant with a shuttered lantern to a distant hill with instructions to open his lantern when he first saw the light from a similar lantern operated by Galileo. Galileo planned to measure the time required for the light to travel to his assistant and back. This attempt was doomed to failure. The reaction times involved in opening the lanterns were much greater than the actual time of flight for the beam of light.

Although astronomers had made estimates of the speed of light, the first successful land-based measurement was made by Armand-Hippolyte Fizeau (1819–1896) in 1849. He used a toothed-wheel apparatus like the one pictured in figure 16.4. A light beam passes through the gap between the teeth of the rotating wheel and is reflected from a distant mirror. The beam will be blocked on its return if the wheel has rotated just far enough so that a tooth is in the place where the gap had been. By measuring the rotational speed of the wheel and knowing the distance that the light beam traveled to get back to the wheel, Fizeau could calculate the speed of light.

The speed of Fizeau's wheel allowed a tooth to move into the former position of a gap in less than  $\frac{1}{10,000}$  of a second. Even at that rate, he had to place his reflecting mirror at a distance more than 8 kilometers (about 5 miles) from the wheel. Knowing that the light beam traveled more than 10 miles in less than  $\frac{1}{10,000}$  of a second in Fizeau's experiment may give you some appreciation of the enormous magnitude of the speed of light.

The speed of light is an important constant of nature, so we give it its own symbol,  $c$ , its value in a vacuum. This value is now defined as  $c = 2.99792458 \times 10^8$  m/s, very close to the  $3 \times 10^8$  m/s value that we usually quote and remember. Light (and other forms of electromagnetic waves) travels

somewhat more slowly in other media, such as glass or water, but the speed of electromagnetic waves in air is very close to their speed in a vacuum.

### Are there different kinds of electromagnetic waves?

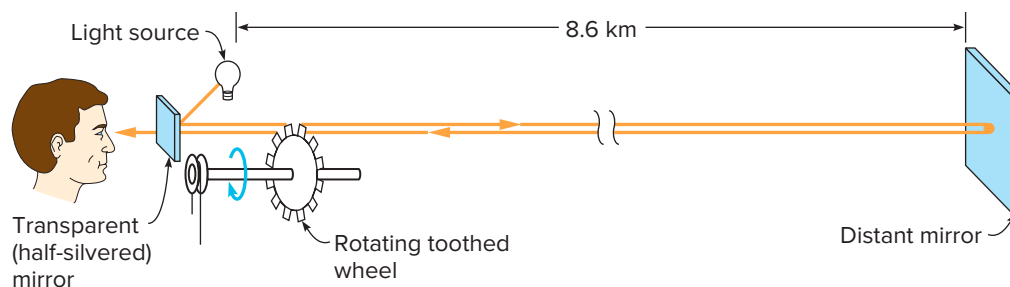
We have already noted that both radio waves and light waves are electromagnetic waves. Are they the same, or do they differ in some significant respect? The main difference between radio waves and light waves lies in their wavelengths and frequencies. Radio waves have long wavelengths (several meters or more), while light waves have very short wavelengths (less than a micron, which is one-millionth of a meter).

Because different types of electromagnetic waves all travel with the same speed in a vacuum (as well as in air, approximately), their frequencies are related to their wavelengths by the relationship  $v = f\lambda$ , where the speed  $v$  is equal to  $c$ . The frequencies for typical wavelengths of radio waves and light waves are computed in example box 16.1. With their shorter wavelengths, light waves have much higher frequencies than radio waves.

If the frequency is known, we can also use the relationship between wavelength and frequency to compute the wavelength. An AM radio station broadcasting at a frequency of 600 kilohertz produces radio waves with a wavelength of 500 m, which we find by dividing the speed of light by the frequency ( $\lambda = c/f$ ). Radio waves in the AM band have very long wavelengths.

Figure 16.5 shows the wavelength and frequency bands for various parts of the **electromagnetic spectrum**. The waves in different parts of this spectrum differ not only in their wavelength and frequency but also in how they are generated and what materials they will travel through. X-rays, for example, will pass through materials that are opaque to visible light. Radio waves will also pass through walls that light cannot penetrate.

Light wavelengths are associated with color and range from roughly  $3.8 \times 10^{-7}$  m at the violet end of the visible spectrum to  $7.5 \times 10^{-7}$  m at the red end. The colors change progressively from violet through blue, green, yellow,



**Figure 16.4** A diagram of Fizeau's toothed-wheel apparatus for measuring the speed of light. As the rapidly spinning wheel turns a small fraction of a revolution, the returning light beam is blocked by a tooth on the wheel.

orange, and red as the wavelengths lengthen. Electromagnetic waves with wavelengths somewhat longer than the red end of the visible spectrum are called **infrared light**, and waves with shorter wavelengths than the violet end are called **ultraviolet light**. Although X-rays and gamma rays have even shorter wavelengths than ultraviolet light, they, too, are electromagnetic waves.

Electromagnetic waves undergo interference phenomena like other kinds of waves. Interference of light can produce striking effects, some of which are discussed in section 16.3. Radio waves reflected from belts of charged particles in the atmosphere can interfere with those coming directly from the transmitter, causing the station to fade in and out.

### Example Box 16.1

#### Sample Exercise: Frequencies of Two Kinds of Electromagnetic Waves

What are the frequencies of the following?

- Radio waves with a wavelength of 10 m
- Light waves with a wavelength of  $6 \times 10^{-7}$  m

$$\begin{aligned} \text{a. } \lambda &= 10 \text{ m} & v &= f\lambda = c \\ v &= c = 3 \times 10^8 \text{ m/s} & f &= \frac{c}{\lambda} \\ f &= ? & &= \frac{3 \times 10^8 \text{ m/s}}{10 \text{ m}} \\ & & &= \mathbf{3 \times 10^7 \text{ Hz}} \end{aligned}$$

$$\begin{aligned} \text{b. } \lambda &= 6 \times 10^{-7} \text{ m} & f &= \frac{c}{\lambda} \\ f &= ? & &= \frac{3 \times 10^8 \text{ m/s}}{6 \times 10^{-7} \text{ m}} \\ & & &= \mathbf{5 \times 10^{14} \text{ Hz}} \end{aligned}$$

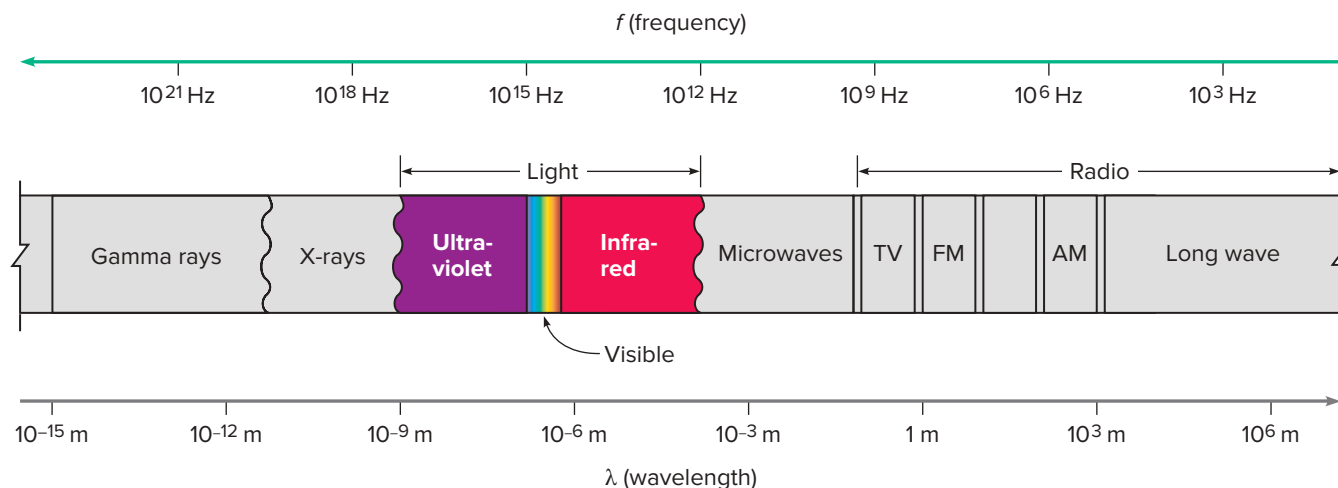
The frequency of light waves is over 10 million times larger than the frequency of the 10-m radio waves.

How different types of electromagnetic waves are produced varies enormously for the different parts of the spectrum, but they all involve accelerated charged particles. The accelerated charges can be in an oscillating electric circuit as in radio waves, or within atoms as in light, X-rays, and gamma rays. Like any warm body, your body is radiating electromagnetic waves in the infrared part of the spectrum. In this case, oscillating atoms within the molecules of your skin serve as the antennas.

### Debatable Issue

Concerns have been raised regarding the possible health effects from the high-frequency electromagnetic waves involved in the use of cell phones. Although this radiation has very low energy and there is no direct evidence of damage to human tissue at these energies, we lack long-term studies that might provide definitive evidence of the safety (or lack thereof) of heavy use of cell phones. Lacking that evidence, should restrictions be placed on cell-phone use?

Maxwell's theory of electric and magnetic fields predicted that a wave involving these fields could be propagated through a vacuum. We call these waves electromagnetic waves. Their speed in a vacuum is approximately 300 million meters per second, as predicted by Maxwell. Because this value was known to be the speed of light, light was identified as an electromagnetic wave, along with radio waves, microwaves, X-rays, and gamma rays, which were discovered after Maxwell's work. Various kinds of electromagnetic waves differ from one another in their wavelengths and frequencies, as well as in how they are generated. They all are waves, however, and they exhibit the general properties of wave motion.



**Figure 16.5** The electromagnetic wave spectrum. Both wavelengths and frequencies are shown for different parts of the spectrum.

## 16.2 Wavelength and Color

We live in a colorful world, and we learn to distinguish colors when we are in preschool. How do we do this? What causes different objects to have different colors? Why is the sky blue? These phenomena are related to the wavelength of light, the properties of different materials, and how we see. In this section, we will explore a variety of aspects of color and color vision.

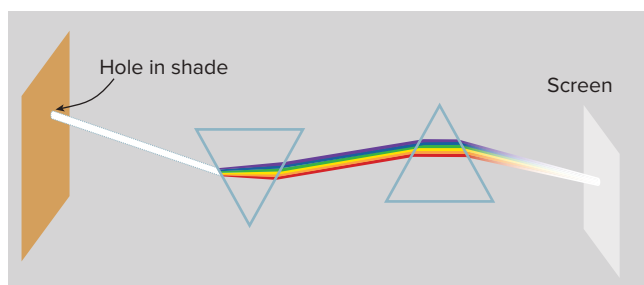
### Does light consist of different colors?

If you have ever played with a prism, you are aware that a prism can produce a rainbow of color. If we allow a beam of white light from a small lightbulb or from the sun to strike a prism, the prism will bend the beam. The emerging beam does not appear white, however. Instead, it is multicolored, with violet light appearing on one side of the emerging beam and red light on the other end. In between, we find blue, green, yellow, and orange.

One of the first people to study this phenomenon systematically was Isaac Newton. Newton is best known for his work in mechanics, but he also did extensive work in optics. In one experiment, he produced a narrow beam of sunlight by passing it through a hole in his window shade. He passed this beam through a glass prism and displayed the colorful *spectrum* of light we have just described. This seemed to demonstrate that white light has within it light of different colors.

Newton did not stop with that observation, however. He passed the light emerging from the prism through a second, identical prism that was inverted relative to the first prism (fig. 16.6). The light emerging from the second prism was white, like the original sunbeam. The different colors when recombined produced white light. These studies of Newton demonstrated that white light is a mixture of different-colored components.

We now know that the different colors of light that Newton observed are associated with the wavelength of light. As mentioned in section 16.1, violet light has shorter wavelengths than red light, with the other colors of the spectrum having intermediate values. These wavelengths can be measured by interference experiments, which we will discuss in



**Figure 16.6** Newton showed that white light from the sun, after being split into different colors by one prism, could be recombined by a second prism to form white light again.

sections 16.3 and 16.4. The wavelengths are extremely short, however, and it is not surprising that Newton was not convinced that they existed. The wavelengths of visible light are roughly one-hundredth the diameter of a human hair!

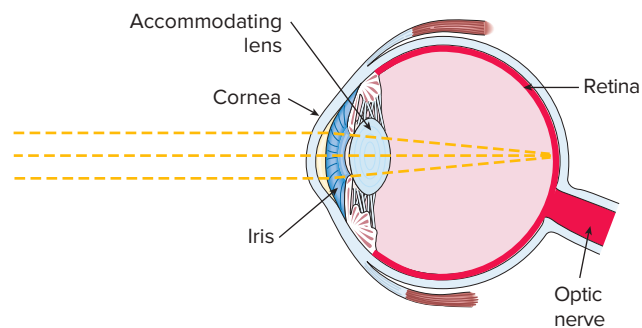
We usually express the wavelengths of visible light in nanometers (nm). One nanometer is equal to  $10^{-9}$  meters, or one-billionth of a meter. The wavelengths of visible light range from 380 nm on the violet end of the visible spectrum to 750 nm on the red end. Table 16.1 shows approximate wavelength ranges for the various colors of the visible spectrum.

### How do our eyes distinguish different colors?

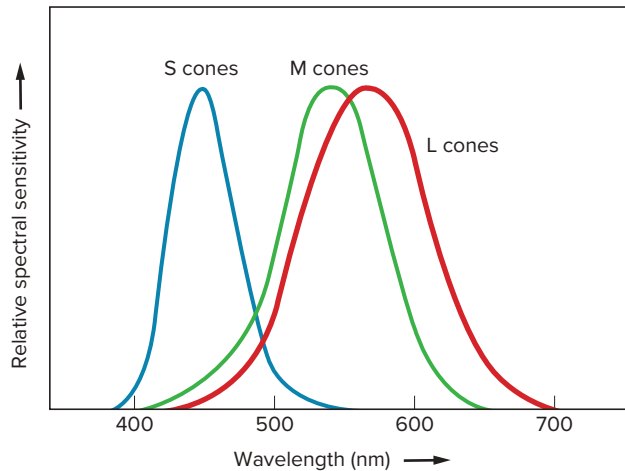
Even though the wavelengths of visible light are extremely short, our visual systems can readily distinguish different colors. Our eyes are the front end of our visual system, but our brains are also heavily involved in how we see. Figure 16.7 shows a simplified diagram of some of the structures of the eye.

Light is focused by the cornea and crystalline lens onto the retina. The retina is made up of light-sensitive cells of two types: *rods* and *cones*. The cones are concentrated near the center of the retina in an area called the fovea and are responsible for our daylight and color vision. The rods are distributed throughout the retina and are responsible for our

Color	Wavelength (nm)
Violet	380–440
Blue	440–490
Green	490–560
Yellow	560–590
Orange	590–620
Red	620–750



**Figure 16.7** Light entering the eye is focused by the cornea and accommodating lens to form an image on the retina. The retina contains light-sensitive cells that send signals to the brain via the optic nerve.



**Figure 16.8** The three different types of cones are sensitive to different wavelengths of light, but their ranges overlap.

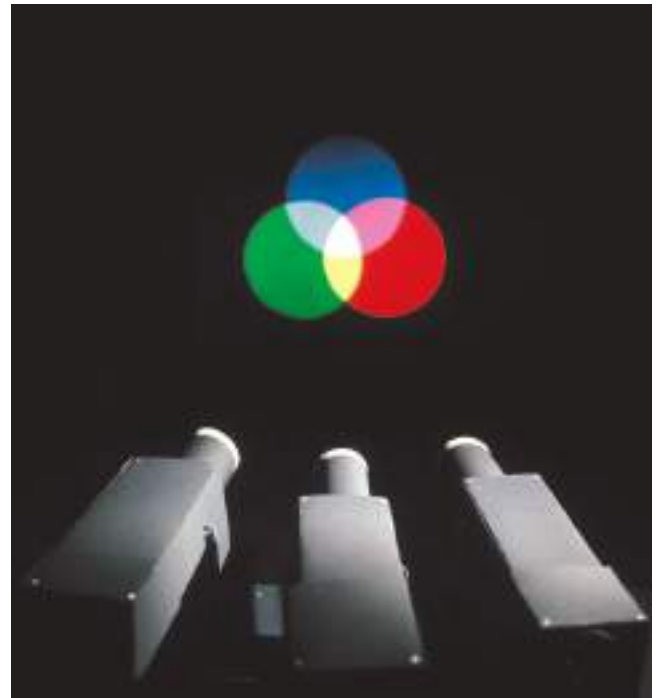
nighttime and peripheral vision. The rods do not provide any information on color—we are color blind at night or in other low-light conditions.

The cones dominate our vision in well-lit conditions and provide our ability to see fine detail as well as color. There are three types of cones—S cones, M cones, and L cones—which are sensitive to light in different parts of the spectrum. The S cones are most sensitive to the shorter (hence S) wavelengths, the M cones to medium wavelengths, and the L cones to longer wavelengths (fig. 16.8). The sensitivity ranges overlap, however, so that light near the middle of the visible spectrum will stimulate all three cone types.

How do we identify different colors, then? Suppose light of 650-nm wavelength enters our eyes. From the cone sensitivity curves, we can see that this light will stimulate the L cones more strongly than the M cones, which in turn are stimulated much more than the S cones. From childhood experience in identifying colors, we have learned to identify this mix of signals as the color red. In a similar fashion, light of 450 nm will stimulate the S cones most strongly, and we identify that color as blue.

Light of 580-nm wavelength stimulates both the M and L cones strongly, and we identify this color as yellow. However, a mixture of red light and green light will produce a similar response, and we will also perceive this mixture as yellow. This is essentially the process underlying **additive color mixing**. Combining the three primary colors blue, green, and red in different amounts can produce responses in our brains corresponding to all of the colors we are used to identifying. Red and green produce yellow, blue and green produce cyan (blue-green), and blue and red produce magenta, as shown in figure 16.9.

Combining all three primary colors in appropriate amounts produces a response that we identify as white. This is true despite the fact that all of the wavelengths that make up the white light of the sun may not be present. We perceive white, though, because the cones are being stimulated in a similar



**Figure 16.9** Additive color mixing is demonstrated by projecting blue, green, and red light from separate projectors onto overlapping circles on a screen. *George Resch/Fundamental Photographs, NYC*

proportion to the response that sunlight produces. When light levels are very low compared to the background, we see black, which is essentially the absence of light.

### Why do objects have different colors?

Why does a blue dress appear blue or a green shirt green? Most objects are not producers of light; they merely reflect or scatter light coming from other sources. The color that we perceive depends on the wavelengths present in the light source, as well as on the manner in which the object reflects or scatters the light.

The color mixing done by artists on their palettes is another way of producing different colors. The pigments used in paints or dyes used on fabrics work by **selective absorption**, meaning that they absorb some wavelengths of light more than others. When light is absorbed, the energy contained in the light wave is converted to other forms of energy, usually thermal energy. The object doing the absorbing becomes warmer.

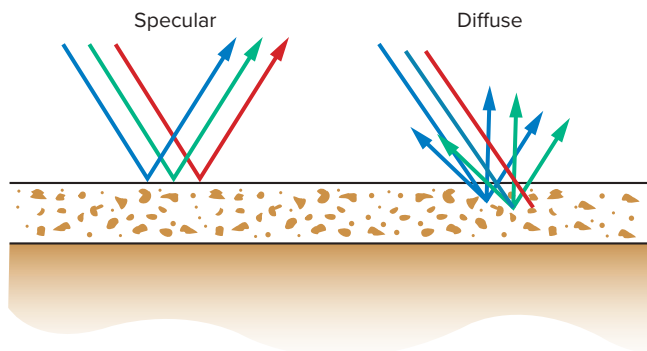
The selective absorption of light is a subtractive process that can also be used to produce a complete range of colors. Suppose we illuminate a blue-green (cyan) book with an incandescent lightbulb. An incandescent lamp produces light by heating a tungsten filament to a very high temperature, causing it to glow. A continuous range of wavelengths results, similar to the white light produced by the sun but usually containing a higher intensity of light in the red end of the spectrum.

When this light strikes the book, a number of things can happen. If the book cover is glossy, some of the light undergoes *specular* reflection (fig. 16.10). Specular reflection is mirrorlike; the light is reflected in a specific direction defined by the law of reflection. (The law of reflection and the behavior of mirrors are discussed in chapter 17.) Light that is reflected in this manner will usually appear as a white glare, the color of the lightbulb.

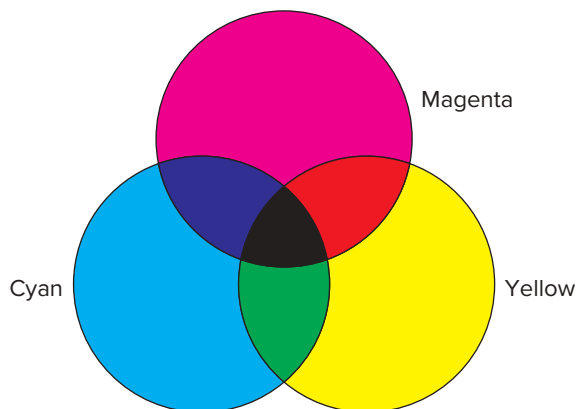
The rest of the light will be reflected *diffusely*, meaning that it is reflected in all directions. This may be due to the surface being somewhat rough, but it also results from penetration of the light a small distance into the surface of the book, as shown in figure 16.10. When this happens, some of the light may be selectively absorbed by particles of pigment in the surface coating. If the book appears blue-green, the pigments are selectively absorbing red light, leaving an excess of blue and green wavelengths in the diffusely reflected light. The pigments are subtracting some wavelengths coming from the white light source, producing an altered mix of wavelengths in the reflected light.

**Subtractive color mixing** has its own set of rules. In color printing, three primary pigments are used: cyan, yellow, and magenta. (Black ink is also used to darken some colors.) Cyan (blue-green) absorbs strongly in the red portion of the spectrum but transmits and reflects blue and green wavelengths. The yellow pigments absorb in the blue but transmit and reflect green and red. Magenta absorbs at intermediate wavelengths but transmits and reflects blue and red.

When light is reflected from a surface coated with just one of these pigments, we see the colors appropriate to that pigment: cyan, yellow, or magenta. If we mix these pigments, however, we can get a complete range of colors. For example, if we mix cyan and yellow pigments, both blue and red light are absorbed (fig. 16.11), allowing only intermediate wavelengths to be transmitted. This results in green light being strongly reflected. Likewise, cyan and magenta produce blue, and yellow and magenta produce red. These resulting colors (green, red, and blue) are the three primary colors for *additive* color mixing, which generate the responses in our eyes described earlier.



**Figure 16.10** Specular reflection obeys the law of reflection with all colors reflected equally. In diffuse reflection, light rays penetrate a short distance and some wavelengths are absorbed.



**Figure 16.11** Subtractive color mixing is demonstrated by overlaying yellow, magenta, and cyan pigments used in color printing.

There is much more to color perception than this basic discussion can cover. Adding white reduces the *saturation* of the color, producing pink from red, for example. The wavelengths present in the light source illuminating an object will affect the perceived color. Although the details may be complex, the same basic phenomena are at work in all of these effects. Different mixes of wavelengths stimulate the different cones in the retina by different amounts, and our brains identify that response as a certain color. (See everyday phenomenon box 16.1 for some related color effects.)

The white light coming from the sun is actually a mixture of light of different wavelengths. This was first demonstrated by Isaac Newton using two prisms first to separate sunlight into a spectrum of different colors and then to recombine these into white light with the second prism. Three different types of light-sensitive cells (called cones) in the retinas of our eyes allow us to distinguish different colors. The light reaching our eyes consists of mixtures of wavelengths that determine the color we perceive. The rules of color addition and subtraction are based on how these various mixtures stimulate the three types of cones.

## 16.3 Interference of Light Waves

During the seventeenth and eighteenth centuries, scientists debated whether light was a wave phenomenon or a stream of particles. Most of the known effects could be explained by either model. Interference, however, is inherently a wave effect. The question would be settled if interference effects involving light could be produced.

In 1800, a British physician, Thomas Young, performed his famous double-slit experiment demonstrating interference of light. Why did it take this long for light interference to be recognized? The very short wavelengths of visible light make the effects subtle and difficult to observe. Once this difficulty was

## Everyday Phenomenon

## Box 16.1

### Why Is the Sky Blue?

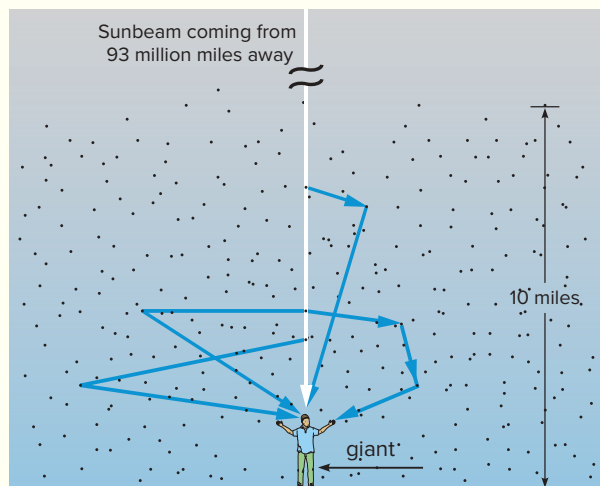
**The Situation.** “Why is the sky blue?” This is a question almost any parent is likely to hear from his or her child at some point. Related questions such as “Why is there a sky?” or “Why is the sun red at sunset?” can also stymie parents.

We know that light coming directly from the sun appears white at midday. It contains a continuous mix of visible wavelengths peaking in the green-yellow portion of the spectrum. Why do we see a blue sky, then? What causes the spectacular oranges and reds we see at sunset? These phenomena are all related to a process called *scattering*.

**The Analysis.** Before we consider the color of the sky, we should ask why we see a sky at all. Where is the light coming from? Sky-light comes from the sun, but it is *scattered* out of the direct beam of sunlight. **Scattering** can be described as a process in which light is absorbed by small particles in the atmosphere and quickly re-emitted at the same wavelength. The scattered light travels in a different direction from that of the incident light, though.

If there were no atmosphere, then there would be no scattering. In this case, the sky would appear black, the absence of light. The Earth does have an atmosphere that extends a few miles beyond Earth’s surface. This atmosphere consists primarily of molecules of nitrogen and oxygen, as well as smaller quantities of other gases. In addition there are often particles of smoke, volcanic ash, or other particulate matter. These particles are very small, but still considerably larger than individual gas molecules.

It is scattering by the gas molecules that is primarily responsible for the blue sky. When the particles doing the scattering are smaller than the wavelength of light, the process is called *Rayleigh scattering*, named after Lord Rayleigh (William Thompson). Rayleigh scattering depends on the wavelength—shorter wavelengths are scattered much more effectively than longer wavelengths.



Short wavelengths (blue light) are scattered from the direct beam of the sun more effectively than longer wavelengths. Most of the gas molecules that scatter light are in the lowest 10 miles of the atmosphere.

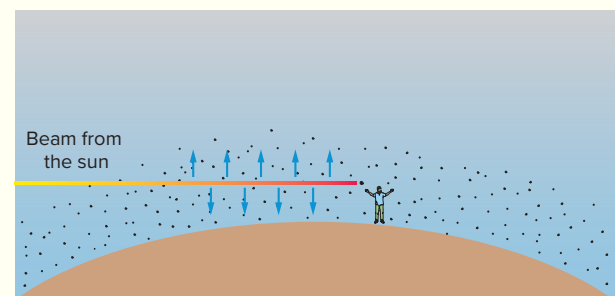
We can think of the molecules as tiny antennas. Because gas molecules consist of charged particles (chapter 18), when an electromagnetic wave strikes the molecules, these charges will oscillate at the frequency of the wave. Just as radio waves are produced by oscillating electric currents, the scattered light wave is produced by oscillating currents in the gas molecules. This process is most efficient when the wavelength of the wave is approximately the same size as the antenna. Because gas molecules are just a few nanometers in size, and the wavelengths of visible light are a few hundred nanometers, the scattering process is not very efficient. It is more efficient, however, for the shortest wavelengths—those in the blue region of the visible spectrum.

This is why the sky is blue. Blue light is scattered out of the direct beam from the sun more effectively than red or intermediate wavelengths. To reach our eyes, it must be scattered again, perhaps several times, as shown in the first drawing.

When we see the sky, we are not looking directly at the sun (which would be painful). We are seeing light that has been scattered multiple times, which concentrates the shorter blue and violet wavelengths in the light that reaches our eyes. Because the spectrum of sunlight contains more blue than violet, and our eyes respond more strongly to blue wavelengths than to violet, the color we identify is blue.

Why does sunlight appear orange or red near sunset or sunrise? The light reaching our eyes from the direct beam of the sun at sunset travels a much longer distance through the atmosphere than it does at midday, as shown in the second drawing. Because the blue light and intermediate wavelengths are scattered out of the beam more effectively than red light, the direct beam is left with predominantly red wavelengths. The closer the sun gets to the horizon, the redder the sun appears.

Scattering can also occur from larger particles, such as water droplets in clouds. Water droplets are usually larger than the wavelengths of visible light. In this case, the amount of scattering does not depend strongly on the wavelength. Light scattered from clouds therefore appears white or gray. All wavelengths are equally scattered and the resulting color is the same as the incoming sunlight, but less intense.



At sunset, light from the sun travels farther through the atmosphere than at midday. The shorter wavelengths are scattered out of the beam, leaving the longer red wavelengths.



recognized, the door was opened for a series of predictions and experiments that firmly established that light is a wave.

### Young's double-slit experiment

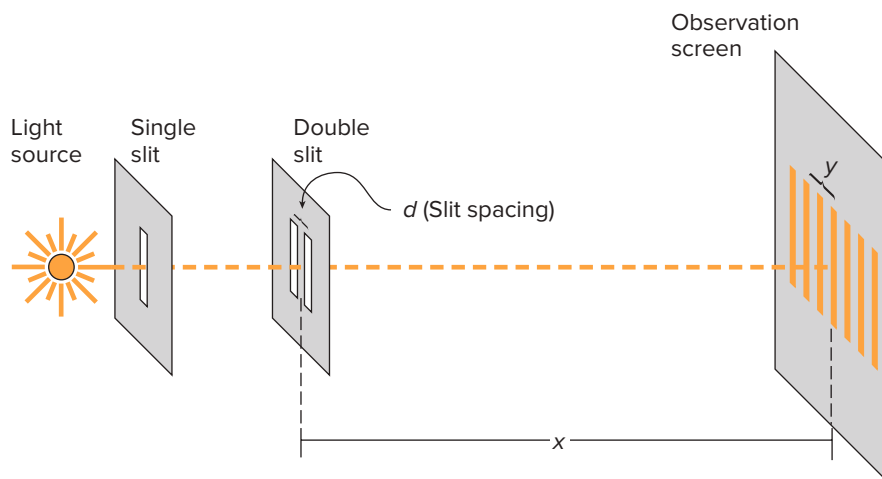
In any interference experiment, we need at least two waves that have a consistent phase relationship with each other, like the two waves on the ropes discussed in chapter 15. The phase of ordinary light waves is continually changing, however, so we need to start with an isolated light wave and split it into two or more parts to meet this condition. Young accomplished this by passing a light beam through two narrow, closely spaced slits.

A diagram of Young's arrangement is shown in figure 16.12. Light from the source first passes through a single slit to isolate a small portion of the beam. This light then strikes the double slit, and light passing through the two slits is viewed on a screen to the right of the slits. Young made his double slits by depositing carbon black on a microscope slide and inscribing two fine lines in this black layer with a thin knife or razor. To be effective for visible light, the spacing of the two slits should be less than a millimeter.

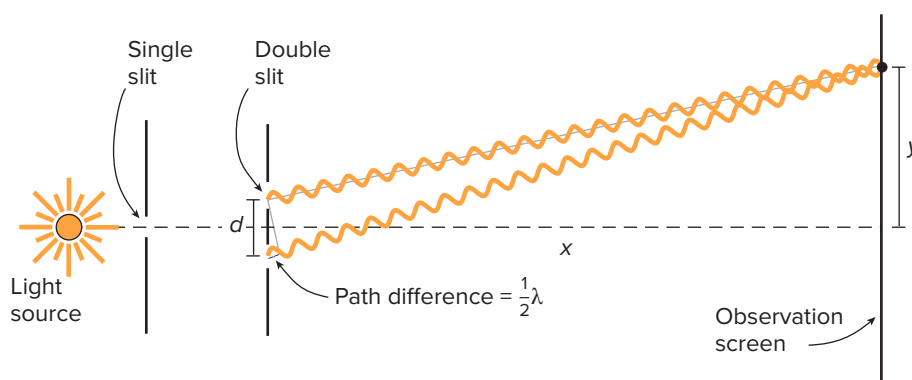
What determines whether the light waves coming from the two slits will interfere constructively or destructively? At the point where the center line between the two slits meets the screen, the two light waves have traveled equal distances from each slit. The two waves were in phase initially, because they came from a single wave. Having traveled equal distances to reach the center point, they are still in phase when they strike the screen. They interfere constructively and produce a bright spot or line at the center of the screen.

What about other points on the screen? The two waves reaching points on either side of the center line have traveled *unequal* distances, which means they may no longer be in phase with each other. Because it takes more time to travel a longer distance, when they reach the screen, the wave traveling the longer distance is at a different point in its cycle than the one traveling the shorter distance. If the difference in distance is just half a wavelength, the two waves will be half a cycle out of phase, and destructive interference results (fig. 16.13). This produces a dark spot or line on the screen.

Suppose the distances traveled by the two waves differ by a full wavelength. The waves are then back in phase, because



**Figure 16.12** Light from the source passes through a single slit before striking the double slit in Young's experiment. Interference fringes are observed on the screen. (The spacings of the double slit and the fringes are exaggerated in this drawing.)



**Figure 16.13** When the path difference between the two waves is equal to half a wavelength, the two waves arrive at the screen half a cycle out of phase, producing destructive interference.

a full-cycle difference brings the wave oscillation back to the initial stage in its cycle. Differences in the distance traveled of one wavelength, two wavelengths, three wavelengths, and so on produce constructive interference and bright lines on the screen. At positions halfway between the bright lines, the waves are half a cycle out of phase, so destructive interference produces dark lines at those points.

The resulting interference pattern of alternating bright and dark lines on the screen is called a *fringe* pattern. If *monochromatic* (single-wavelength) light is used, this pattern can extend to several fringes. If white light (which consists of a mixture of wavelengths) is used, the pattern is visible for only one or two fringes on either side of the center, because the different wavelengths produce constructive interference at different points on the screen. (Why is this so?) Although limited in extent, the fringes are colored and display a visually striking result.

### What determines the spacing of the fringes?

We can predict the positions of the bright and dark fringes on the screen by knowing the wavelength of the light and the geometry of figure 16.13. The path difference between the two waves is the critical quantity. If the screen is not too close to the double slit, the path difference can be found from the geometry of the drawing and is given approximately by

$$\text{Path difference} = dy/x$$

where  $d$  is the distance between the centers of the slits,  $y$  is the distance from the center point on the screen, and  $x$  is the distance between the screen and the slits. As indicated earlier, if this path difference is equal to an integer times the wavelength, constructive interference results (see example box 16.2).

### Example Box 16.2

#### Sample Exercise: Working with the Double-Slit Experiment

Red light with a wavelength of 630 nm strikes a double slit with a spacing of 0.5 mm. If the interference pattern is observed on a screen located 1 m from the double slit, how far from the center of the screen is the second bright line from the central (zeroth) bright line?

$\lambda = 630 \text{ nm} = 6.3 \times 10^{-7} \text{ m}$       Because we are interested  
 $d = 0.5 \text{ mm} = 5 \times 10^{-4} \text{ m}$       in the second bright fringe  
 $x = 1 \text{ m}$       from the center, the path  
 $y = ?$       difference is

$$d \frac{y}{x} = 2\lambda.$$

Rearranging this expression yields

$$\begin{aligned} y &= \frac{2\lambda x}{d} \\ &= \frac{2(6.3 \times 10^{-7} \text{ m})(1 \text{ m})}{(5 \times 10^{-4} \text{ m})} \\ &= \mathbf{0.0025 \text{ m} = 2.5 \text{ mm}} \end{aligned}$$

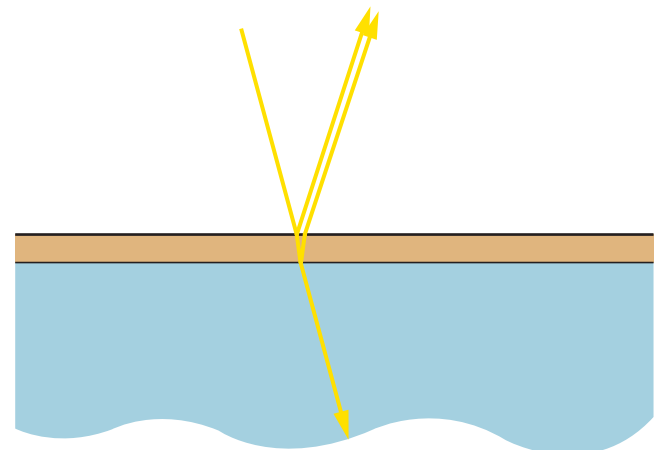
As the result in example box 16.2 indicates, the second bright fringe from the center is only 2.5 mm from the center of the screen, for a slit separation of half a millimeter. The first bright fringe from the center would be found at half this distance, or only 1.25 mm from the center. These fringes are very closely spaced, which can make them difficult to see. A smaller slit spacing  $d$  yields a larger fringe separation, as you can see from the equation for  $y$  in example box 16.2. In Young's day, considerable experimental ingenuity was needed to produce slit spacings as small as half a millimeter. Today, we can do this readily by using photographic reduction and other techniques.

### What is thin-film interference?

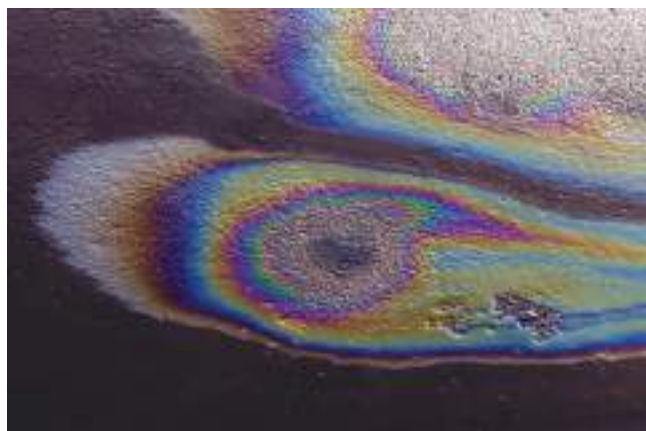
If you have ever observed bands of different colors on a soap film or on the oil slick on a parking lot puddle, you have observed **thin-film interference**. How do these colors arise? Light waves reflected from the top and bottom surfaces of the film interfere to produce these effects.

Figure 16.14 shows a very thin film of oil lying on top of a water puddle. In order to be effective, the film must be no thicker than a few wavelengths of light. The underlying water is assumed to be much thicker (often several millimeters) than the oil film, which is a fraction of a micrometer. Two waves are shown being reflected from the film, one from the top surface and the other from the bottom surface. When these two waves reach our eyes, the one reflected from the bottom of the film has traveled slightly farther than that reflected from the top. Just as with the double-slit experiment, this path difference will cause a difference in phase between the two waves.

Because the two reflected waves are almost perpendicular to the surface of the film, the difference in distance traveled will be twice the thickness of the film. The wave reflected from the bottom surface passes through the film twice. The effect of this path difference is related to the wavelength of light in the film, which is shorter in the film than it is in air. (The wavelength in



**Figure 16.14** Two waves interfere after reflection from a thin film of oil lying on water. One wave is reflected from the top surface of the film and the other from the bottom surface.



**Figure 16.15** The colorful fringes from oil films are a common sight in parking lots and streets. The various colors result from changes in thickness of the film or from differing angles of view.  
*art nick/Shutterstock*

the film is given by  $\lambda/n$ , where  $n$  is the index of refraction of the film, discussed in chapter 17, and  $\lambda$  is the wavelength in air.)

The phase difference between the two reflected waves depends on how many wavelengths farther the wave reflected from the bottom surface has traveled. If, for example, the wave reflected from the bottom surface traveled a half wavelength farther than the wave reflected from the top surface, then the two waves would be out of phase, and we would expect to observe destructive interference.\*

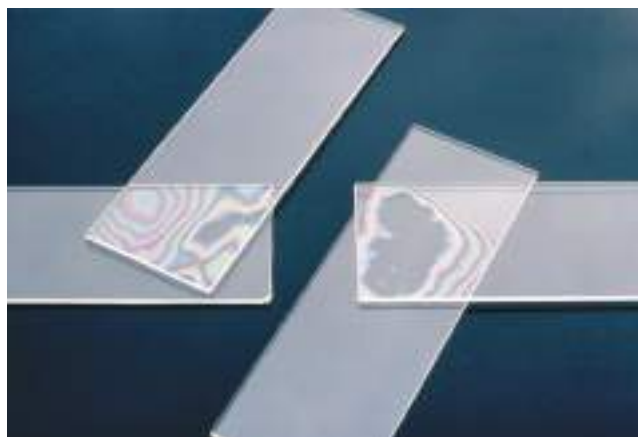
Why do we see different colors? The interference condition depends on the thickness of the film and on the wavelength of the light. Some wavelengths may interfere destructively, while others interfere constructively (or somewhere in between). If the thickness of the oil film is such that we have destructive interference for wavelengths near the middle of the spectrum (green-yellow), then those wavelengths will be missing and we will see a mixture of blue and red (magenta). If, on the other hand, the thickness is such that we get destructive interference for red light, the film will appear blue-green. The usual rules of color addition apply.

The colors reflected by the oil film will thus depend on the thickness of the film. As the thickness changes, the color will change (fig. 16.15). The path difference between the two reflected waves also depends on the angle of the incoming and reflected light. If light is incident on the film from multiple angles, the colors will change with the viewing angle as the path difference changes.

There are many other ways of producing thin-film interference. Soap bubbles and soap films can produce colorful displays. The thin film in this case is a soap-water solution with air on either side.

When the soap film gets extremely thin (just before it breaks), the path difference between the two surfaces should approach zero. In this case, we would expect the

\*This is true if there are no other factors affecting the phase of the wave. The reflection process itself sometimes changes the phase, so this effect must also be taken into account in a complete analysis.



**Figure 16.16** Colored interference fringes are produced by light reflected from an air film between two glass plates. Each colored band represents a different thickness of the film.  
*David Parker/Science Source*

light waves reflected from the two surfaces to be in phase, producing a bright reflection. Instead, however, the film appears quite dark for this condition, indicating destructive interference. The two waves are out of phase because of a phase difference introduced by the reflection process itself—the wave reflected from the top surface is shifted in phase by a half cycle, while that reflected from the bottom surface is not. The path difference between the two waves produces no phase change, but the reflection process does. This occurs whenever the medium on either side of the film is the same (air in this case), as well as in some other circumstances.

The thin film in some cases can be air. This happens when we place one glass plate on top of another. If the plates are flat and clean, this leaves a very thin film of air between the two plates. As the thickness of the air film varies, we see alternating light and dark fringes (fig. 16.16). We can change the thickness of the trapped air by pushing on the top plate, thus changing the fringe pattern. The color of these fringes depends on the nature of the light source, as well as on the thickness of the film and the angle of view. Thin-film interference is also involved in the antireflection coating on eyeglasses, as described in everyday phenomenon box 16.2.

Interference is observed for many different types of waves, and light is no exception. The wave nature of light was first established by the double-slit interference experiment performed by Thomas Young. If the two waves coming from the two slits travel different distances, they may arrive at the screen either in or out of phase. If the path difference is an integer number of wavelengths, the waves are in phase and we get a bright fringe. If the path difference is a half-integer number of wavelengths, we get dark fringes. Light reflected from the two surfaces of a thin film will also travel different distances. This produces the colorful interference effects observed on soap films, oil films, and the air film between two glass plates.

## Everyday Phenomenon

## Box 16.2

### Antireflection Coatings on Eyeglasses

**The Situation.** When you select new eyeglasses, your optometrist or optician will show you a variety of lens and frame styles. He or she is also likely to recommend that you order antireflection (AR) coatings on your lenses, telling you that this will help you see better in low-light or night driving conditions. You will also look better, because people will be able to see your eyes without the distracting interference of reflections from the lenses.



Can you tell which of the two lenses in these eyeglasses has the antireflection coating? *Photo Researchers/Science Source*

How do these coatings work? How is it possible to reduce the amount of light that is reflected by glass or plastic lenses? Thin-film interference provides the answers.

**The Analysis.** When light strikes the surface of a glass or plastic lens, some light is inevitably reflected. For the types of glass and plastic used in spectacle lenses, approximately 4% of the incident light is reflected at each surface (front and back) when the light comes in perpendicular to the surface. When the light comes in at an angle, the amount of light reflected is even larger.

We therefore lose at least 8% of the incoming light with uncoated lenses. These reflections can be distracting to people you are talking to, since your eyes are an important part of interpersonal communication. The reflections also reduce the amount of light that reaches your retinas in low-light conditions.

An antireflection coating is designed to reduce these reflections. A thin film of transparent material is deposited on both surfaces of the lens. The film must be hard and durable, which limits our selection of the materials that will work. Magnesium fluoride is often used for glass lenses.

The thickness of the film must be carefully controlled. The film is designed to produce destructive interference for reflected light at wavelengths near the middle of the visible spectrum. For a single-layer coating, that film that is used is just a quarter of a wavelength thick. (The wavelength in question is that inside the thin film, which is somewhat shorter than the wavelength in air.) If the design wavelength is 550 nm (in air), the appropriate thickness of the film would be about 100 nm, which is very thin indeed. This is equal to one ten-thousandth of a millimeter!

Because the wave reflected from the bottom surface of the film travels through the film twice, the quarter-wavelength thickness results in a half-wavelength path difference between the waves reflected from the top and bottom surfaces. This produces destructive interference for the design wavelength. If the two reflected waves were equal in amplitude, the destructive interference would be total, and there would be no light reflected at that wavelength. In practice, this condition cannot be achieved, and there will still be a small amount of reflected light.

The coating is most effective for wavelengths near the middle of the visible spectrum. At the red and blue ends of the spectrum, the condition for destructive interference is not met, so we get stronger reflections at either end of the spectrum. The eye is not as sensitive there, however, so these reflections are less noticeable. It does result in the lens having a purplish appearance when viewed in reflected light.

Better results can be achieved by using multiple layers of thin films made from different materials rather than a single layer. The more layers used, the more expensive the process, however. The coatings now available for spectacle lenses are usually multiple-layer coatings. Besides the additional cost, the disadvantage of antireflection coatings is that they scratch and show dirt more readily than noncoated lenses. The buyer must decide whether the advantages of reduced reflections outweigh the disadvantages.

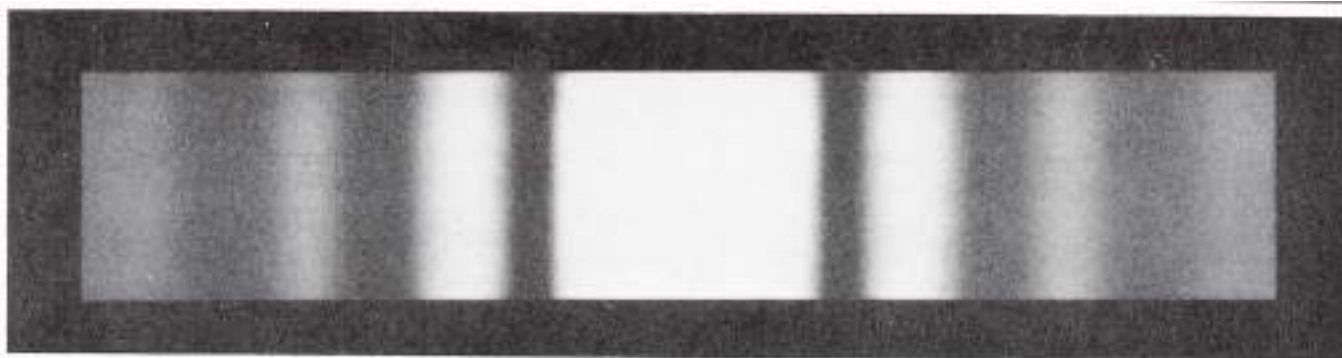
## 16.4 Diffraction and Gratings

If you look closely at a double-slit interference pattern like that described in section 16.3, you might notice that the bright fringes are not all equally bright. Going out from the center of the pattern, the fringes become less bright and seem to fade in and out. This effect is due to another aspect of interference that we usually label **diffraction**. Diffraction

involves interference of light coming from different parts of the same slit or opening.

### How does a single slit diffract light?

Diffraction from a single slit is the easiest to describe. If we replace the double slit shown in figure 16.12 with a sufficiently narrow single slit, a pattern like that shown in



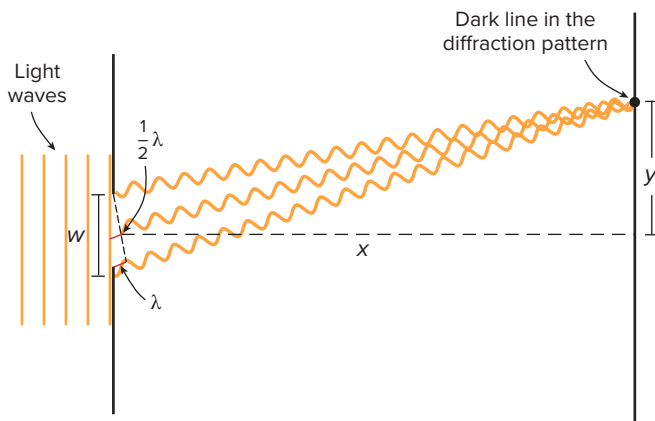
**Figure 16.17** The diffraction pattern for a narrow single slit has a series of light and dark fringes on either side of a bright central fringe.  
Tom Pantages

figure 16.17 results. A series of dark and light fringes lie on either side of a bright central fringe.

The bright central fringe is not surprising. Light waves reaching the center of the screen from different parts of the slit will travel roughly the same distance. They will therefore reach the screen in phase with one another and interfere constructively. They add together to yield the bright fringe we see.

Explaining the other fringes calls for a more elaborate analysis. We can think of the two dark fringes on either side of the central fringe as arising from light coming from the two halves of the slit. If the light coming from the bottom half of the slit travels half a wavelength farther than that coming from the top half, these waves will interfere destructively (fig. 16.18). This produces a dark fringe at the point on the screen for which this condition holds.

A more complete argument involves dividing the slit into several segments. For fringes farther from the center of the pattern, this procedure is necessary to understand the results. Moving out from the center of the pattern, light coming from different segments of the slit comes in and out of phase, producing the fringes we see. The different waves are



**Figure 16.18** When the path difference between light coming from the top half of the slit and that coming from the bottom half is  $\frac{1}{2}\lambda$ , a dark line appears in the single-slit diffraction pattern.

never all in phase at the same point, though, as they were at the center of the pattern, so the central fringe is much brighter than the secondary bright fringes on either side of the center.

For the first dark fringe on either side of the center, the path difference between light coming from the two halves of the slit is half a wavelength. This requires that the path difference for light coming from the top and bottom *edges* of the slit be a full wavelength, as indicated in figure 16.18. From the same geometry used to describe the double-slit pattern, the position  $y$  of the first dark fringe is then given by

$$y = \frac{\lambda x}{w}$$

where  $w$  is the width of the slit, and as before,  $\lambda$  is the wavelength of the light and  $x$  is the distance to the screen. (See example box 16.3.)

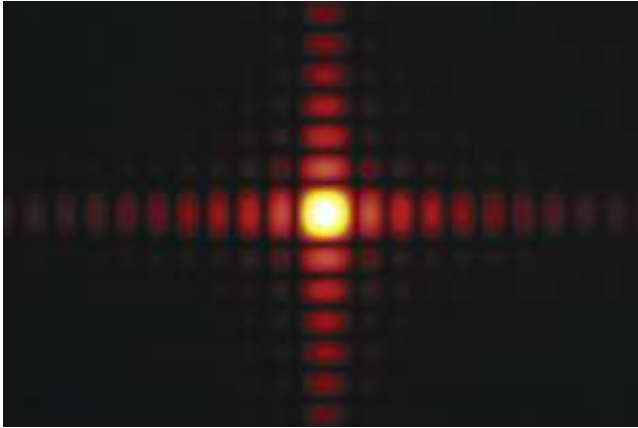
### Example Box 16.3

#### Sample Exercise: How Broad Is the Central Fringe of a Single Slit?

Light with a wavelength of 550 nm strikes a single slit that is 0.4 mm wide. The diffraction pattern produced by the slit is observed on a wall a distance of 3.0 m from the slit.

- What is the distance from the center of the pattern to the first dark fringe?
  - How wide is the central bright fringe of this diffraction pattern?
- a.**  $\lambda = 550 \text{ nm} = 5.50 \times 10^{-7} \text{ m}$   
 $w = 0.4 \text{ mm} = 0.4 \times 10^{-3} \text{ m}$   
 $x = 3.0 \text{ m}$
- $$y = \frac{\lambda x}{w} = \frac{(5.50 \times 10^{-7} \text{ m})(3.0 \text{ m})}{0.4 \times 10^{-3} \text{ m}} = \mathbf{0.0041 \text{ m} = 4.1 \text{ mm}}$$
- b.**  $2y = ?$   $2y = 2(4.1 \text{ mm}) = \mathbf{8.2 \text{ mm}}$

The central bright fringe extends out to the first dark fringe on either side, so its width is just twice  $y$ .



**Figure 16.19** The diffraction pattern produced by a square opening has an array of bright spots. A longer exposure would show more off-axis spots. *GIPhotoStock/Science Source*

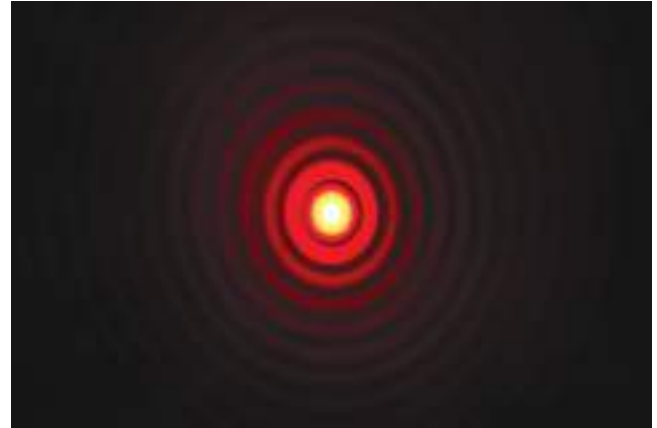
This result is important, because it describes the width of the central bright fringe. This width is  $2y$ , where  $y$  is the distance from the center of the screen to the first dark fringe on either side. As the width  $w$  of the slit decreases, the breadth  $2y$  of the central maximum increases. Thus, as the slit is narrowed, the diffraction pattern spreads out. A beam of light cannot be narrowed indefinitely by passing it through increasingly narrow slits. For a very narrow slit, the central bright fringe is much broader than the slit itself. Light is bent by diffraction into regions that we would expect to be shadowed.

### How is light diffracted by other shapes?

You have probably observed diffraction effects without being aware of them. If you look at a star or a distant streetlight through a window screen, you will observe a diffraction pattern similar to that shown in figure 16.19. A window screen has multiple square openings, but figure 16.19 shows the diffraction pattern produced by just a single square opening in an otherwise opaque object. If we replaced the single slit described earlier with a square aperture, this is what we would see on the screen.

The explanation of the square-opening pattern is similar to the reasoning we used for the single slit. The pattern varies in two dimensions, however, rather than just one dimension, so the explanation is more involved. A rectangular opening would produce a similar pattern, but the spacing of the bright spots would be different in the horizontal direction than in the vertical direction. The narrower dimension of the rectangular opening would produce broader spacing of the diffraction spots.

The openings, or *apertures*, in most optical instruments such as telescopes, microscopes, or our eyes are circular rather than square or rectangular. The diffraction pattern produced by a circular aperture is shown in figure 16.20. This bull's-eye pattern can be produced by poking a small hole in a piece of aluminum foil with a pin. If we then illuminate the hole with a laser pointer or other bright light source, we can see the ringed diffraction pattern on the wall.



**Figure 16.20** The diffraction pattern produced by a circular opening has a bright central spot surrounded by a series of dimmer rings. *GIPhotoStock/Science Source*

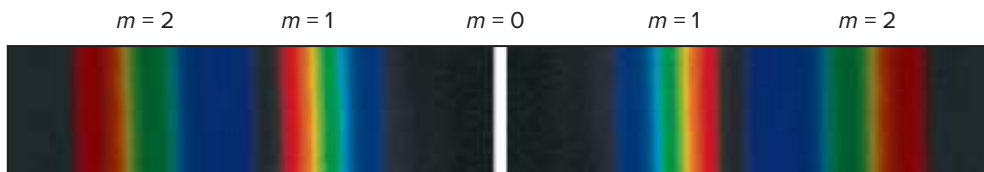
Just as with the single slit, the breadth of the central bright spot increases as we decrease the diameter of the pinhole. This implies that if we make the aperture of our instrument too small in diameter, light from pointlike objects such as stars will be spread out due to diffraction effects. This will produce fuzzy images and will cause nearby stars to blur into one another. We then say that these stars are not *resolved* by our telescope. For this reason, we generally use large mirrors for the opening element of high-quality telescopes. Telescopes will be described more fully in chapter 17.

The pupils of your eyes can vary in size depending on light levels. At high light levels, when our pupils are small in diameter, diffraction effects can limit our visual acuity. A small pupil spreads the light from point objects into larger, blurry circles due to diffraction. Our ability to see fine detail may actually improve at somewhat lower light levels that allow a larger pupil size. Squinting in bright light can produce a similar advantage by opening the pupil and reducing the diffraction effects.

We also see diffraction effects produced by our pupils when we look at stars. Instead of looking like points, the stars often appear to have little spikes of light radiating out from the center. These spikes are produced by diffraction from straight-edge segments of our otherwise circular pupils. These straight edges produce effects that are more similar to those of a single slit than to those of a circular aperture.

### What is a diffraction grating?

A **diffraction grating** is a multiple-slit interference device useful for viewing the color spectrum of a light source. Although the term *diffraction* is used in the name, it would be more appropriate to call these devices *interference gratings*. The primary effect is that of interference of light coming from different slits. Although the terms *interference* and *diffraction* are sometimes interchangeable, we usually use *interference* when referring to effects of separate slits or openings and *diffraction* for effects from a single opening.



**Figure 16.21** A diffraction grating produces a colorful spectrum from a white-light source. The second-order spectrum ( $m = 2$ ) spreads out more than the first-order spectrum ( $m = 1$ ).

Michelle Mauser/McGraw-Hill Education

When you increase the number of slits in an interference experiment, an interesting pattern emerges. If the spacing of the slits remains the same, the bright fringes become brighter and narrower as the number of slits increases. At the same time, a few much dimmer fringes are seen in between the primary bright fringes. For example, if we have four slits, there are two *secondary* dimmer fringes lying between each pair of bright fringes. In general, the number of dimmer fringes is given by  $N - 2$ , where  $N$  is the number of slits. Ten slits would have eight secondary dimmer fringes between each pair of bright fringes.

As we continue to increase the number of slits, these dimmer secondary fringes become very dim, while the bright fringes become very narrow. A diffraction grating has a very large number of slits very closely spaced. A good grating may have several hundred slits in the space of just 1 mm. Precision machines have been designed to produce these closely spaced slits or *lines* needed for producing high-quality gratings. Nowadays, good gratings can be made much more simply using lasers and holographic techniques. (See everyday phenomenon box 21.1.)

The condition for locating the bright fringes produced by a diffraction grating is essentially the same as that introduced for the double slit. If the distance between adjacent fringes is  $d$ , then just as for the double slit, the path difference between waves coming from adjacent slits is  $d \cdot (y/x)$ , where  $y$  is the distance from the center of the viewing screen and  $x$  is the distance from the grating to the viewing screen. Whenever this path difference is equal to an integer multiple of the light wavelength, we get a strong, bright fringe for that wavelength. This condition can be expressed\* as

$$d \frac{y}{x} = m\lambda$$

where  $m$  is an integer having possible values  $0, \pm 1, \pm 2, \pm 3$ , etc.

Because the condition locating the fringes depends on the wavelength of the light, different wavelengths will appear at different points on the screen for a given order,  $m$ . Thus, passing light through a diffraction grating will spread the light into its spectrum of colors (fig. 16.21). A good grating produces a wider separation of colors than a prism and

allows direct computation of the wavelength from the condition for interference.

Diffraction gratings are used to separate and measure the wavelengths of light in instruments called *spectrometers*. They are a common piece of apparatus in chemistry and physics laboratories. Spectrometer measurements have also played an enormous role in astronomy. Our knowledge of the composition of planets, stars, and other objects has resulted from analysis of their light spectra. Our realization that the universe is expanding came from spectrometer measurements of light from distant galaxies (see section 21.2).

Holographically produced gratings are now also seen in many novelty products, including “space glasses” and reflective gift wrappings. The colorful effects we see when viewing a compact disc (CD) are also a grating phenomenon. The disc contains a continuous spiral track that circles the disc from the inside to the outside. Adjacent turns of this spiral track are very closely spaced and act as a reflecting diffraction grating.

Diffraction involves the interference of light waves coming from different parts of the same opening. Diffraction from a single slit produces a bright central fringe with a series of weaker dark and light fringes on either side of the broader central fringe. A circular aperture produces a bull’s-eye pattern. Making the aperture smaller causes the diffraction pattern to spread out, frustrating efforts to narrow a beam of light. A diffraction grating is a multiple-slit interference device that allows us to separate and measure wavelengths of light.

## 16.5 Polarized Light

Many of us have used polarizing sunglasses or camera filters to reduce glare and darken the sky. How do these work? You may have also worn special polarizing glasses to view a 3-D video or movie. In this case, your two eyes are receiving light with different directions of polarization.

What is polarization of light? How does polarized light differ from ordinary light? To answer these questions, we need to revisit the nature of electromagnetic waves.

\*This condition is only valid for relatively small angles from the center of the screen. For larger angles, we must use a more precise condition involving the sine of an angle  $\theta$  to a point on the screen. The exact condition is  $d \sin \theta = m\lambda$ . For small angles,  $\sin \theta \approx y/x$ .

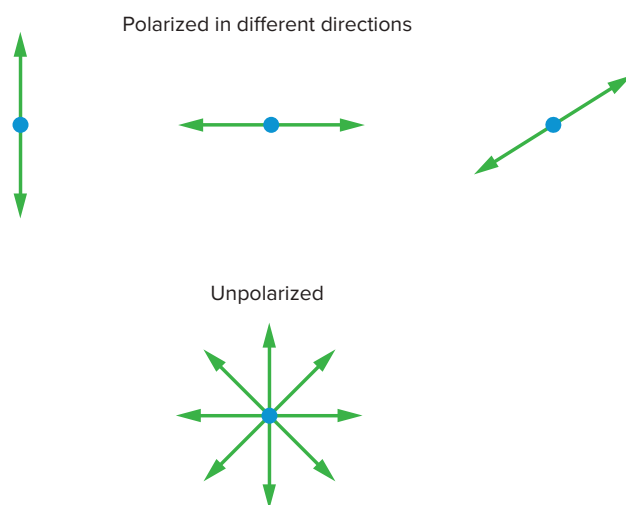
## What is polarized light?

Take a look at the electromagnetic wave pictured in figure 16.3 in section 16.1. Light is an electromagnetic wave consisting of oscillating electric and magnetic fields. The wave pictured in figure 16.3 is actually polarized. The oscillating electric field vector is in the vertical plane in this diagram, and the magnetic field is horizontal.

This is not the only possibility, however. We could have pictured the electric field oscillating in the horizontal direction with the magnetic field in the vertical plane. Or we could have pictured the electric field oscillating at an angle to the horizontal. These choices would all represent different directions of polarization. By convention, we define the direction of polarization of light to be that of the direction of the electric field vector. (The magnetic vector is always there as well, perpendicular to the electric vector.) Figure 16.22 pictures different states of polarization. In these diagrams, the light wave is coming straight out of the page toward you. The electric field vector is represented by a two-headed green arrow, because it is oscillating back and forth as the wave progresses.

How does unpolarized light differ from polarized light? The last diagram in figure 16.22 represents unpolarized light. The electric field vector in this case is shown pointing in several different directions. (In reality, there are an infinite number of possible directions.) **Unpolarized light** is a mixture of many waves having different orientations for the electric field oscillations. Light coming from an ordinary lightbulb is unpolarized. In order to produce **polarized light**, something must occur to select just one direction of field oscillation from these multiple possibilities.

Light or other electromagnetic waves are not the only type of wave that can be polarized. Any transverse wave, including waves on a rope or guitar string, can be polarized. If you wave a rope up and down to produce a traveling wave



**Figure 16.22** The electric field vector oscillates in a single direction for polarized light. Unpolarized light has random directions of oscillation.

on the rope, you produce a vertically polarized wave. If you wave it back and forth in a horizontal plane, you produce a horizontally polarized wave. If you move your hand in random directions, you produce an unpolarized wave.

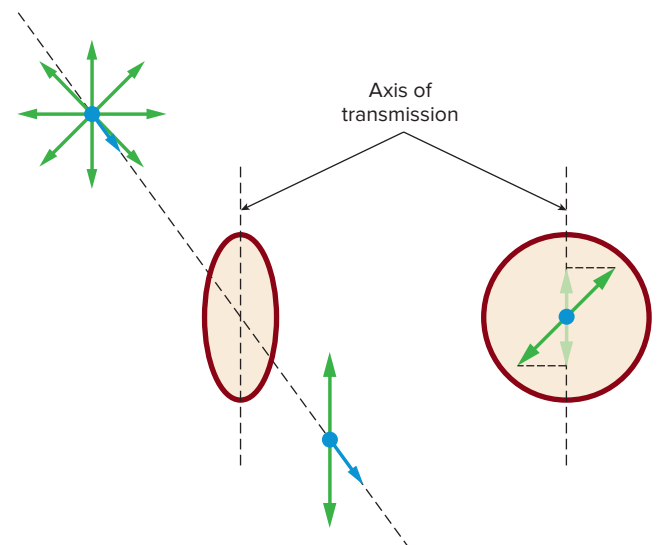
## How do we produce polarized light?

The most common way of producing polarized light is with a polarizing filter (sometimes called a *Polaroid* after the original manufacturer). The early polarizing filters used *dichroic* crystals. These were special materials that absorbed light with one direction of polarization while transmitting light with the perpendicular direction of polarization. The trick in manufacturing the filter was to get a large number of these small crystals all lined up in the same direction.

Later processes used special *polymers* (plastics) to make polarizing filters. By stretching these polymers in the manufacturing process, they become dichroic. The stretching process also assures that the molecules are all aligned in the same direction. Modern polarizing filters are made in this manner. Polarizing filters are routinely available at camera stores, but also as polarizing sunglasses.

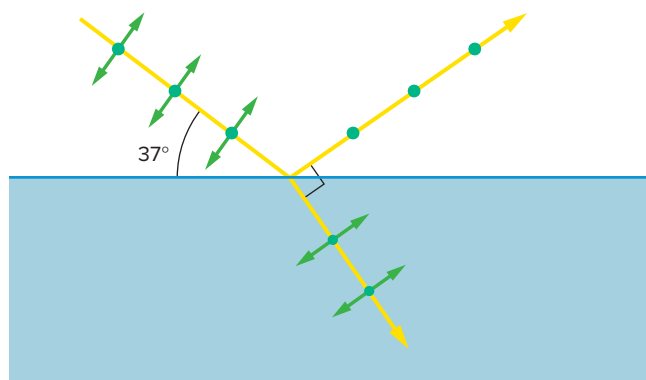
What happens when unpolarized light passes through a polarizing filter? Does it let through only that tiny fraction of light that happens to have the correct orientation of the electric field? Remember that electric fields are vectors. The polarizing filter selects that portion, or *component*, of each electric field vector that has the appropriate orientation. Figure 16.23 illustrates this process. The component of the electric field vector that gets through is the one in the direction of the transmission axis of the filter. The component perpendicular to this axis is absorbed.

An ideal polarizing filter therefore transmits 50% of an unpolarized light beam. The light that emerges is polarized with the electric field in the direction of the



**Figure 16.23** A polarizing filter selects the components of the electric field vector that are in the direction of the transmission axis of the filter.





**Figure 16.24** Unpolarized light incident on a water surface at  $37^\circ$  above the horizontal. The reflected wave is completely polarized with the electric field parallel to the water surface.

transmission axis of the filter. In practice, somewhat less than 50% of the light makes it through the filter, because some absorption takes place even in the direction of the transmission axis.

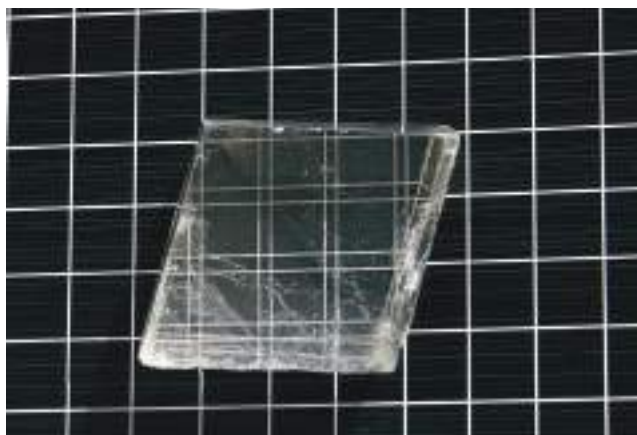
How can we tell whether a beam of light is polarized or not? We place a polarizing filter in the path of the beam and then rotate the filter. If the intensity of the transmitted light varies as we rotate the filter, then we know that the beam is either partially or completely polarized. If the intensity becomes effectively zero for one orientation of the filter, then the light beam being analyzed is completely polarized.

### Why do we use polarizing sunglasses?

There are various ways in which light can become polarized without passing it through a polarizing filter. Reflection from a smooth surface of a transparent material, such as glass or water, can produce polarization, for example. When sunlight is reflected from a lake surface at just the right angle, the reflected wave can be completely polarized.

Figure 16.24 pictures light striking a lake surface at the polarizing angle. The light coming in is unpolarized, as is represented by the arrows both perpendicular to the page (dots) and lying in the plane of the drawing. When the angle between the reflected wave and the transmitted wave is a right angle ( $90^\circ$ ), the reflected wave is completely polarized, with the direction of polarization perpendicular to the page (dots) and thus parallel to the surface of the lake. For water, the polarizing angle is approximately  $37^\circ$  above the horizontal.

How can polarizing sunglasses help? Light reflected from a lake surface will produce a strong glare that can be quite annoying for boaters or water skiers. Because this light is strongly polarized when the sun is at or near the polarizing angle, polarizing sunglasses can virtually eliminate this glare. The reflected light is polarized horizontally, so we want the transmission axis of our sunglasses to be vertical. Even when



**Figure 16.25** Lines are doubled when viewed through a calcite crystal. This effect is called double refraction or birefringence. *Jill Braaten*

the sun is not at the polarizing angle, the reflected light is partially polarized, so the sunglasses will still help.

Polarizing sunglasses can help reduce glare from sunlight reflected by a wet road surface or a polished car hood. They can also help skiers experiencing glare from sunlight reflected from snow. Even skylight is polarized, although here the process involves scattering rather than reflection (see everyday phenomenon box 16.1). It turns out that skylight is partially polarized with the electric field direction horizontal, so polarizing filters make the sky appear darker. This is the primary reason they are used in photography.

### What is birefringence?

Many interesting and colorful effects of polarized light are related to the phenomenon of **birefringence**. Birefringence is also called *double refraction*. Calcite crystals are usually used to demonstrate the effect.

If you draw a small dot on a piece of paper and view this dot through a calcite crystal, you will see two dots rather than one. This is the origin of the term *double refraction*. One of the two dots we see obeys the ordinary rules of refraction (light bending), which are discussed in chapter 17. The light wave associated with this dot (called the *ordinary wave*) passes straight through the crystal.

The wave associated with the second dot is called the *extraordinary wave*, and it does not obey the usual rules of refraction. Instead, the amount of light bending for this wave depends on the direction of the light beam relative to the crystal lattice. The extraordinary wave does not pass straight through the crystal, and thus this dot appears to be offset from the other dot. The photograph in figure 16.25 shows a series of straight lines viewed through a calcite crystal. Each line appears to be doubled due to birefringence.

A simple test using a polarizing filter demonstrates that the two waves associated with the two dots (or lines) are

polarized at right angles to each other. If we view the two lines through the filter, and rotate the filter slowly about our line of sight, first one line disappears. As we continue to rotate the filter an additional  $90^\circ$ , the second line disappears while the first one reappears. The direction of polarization must have something to do with the double-refraction effect.

How can we explain these effects? Crystals can be categorized as either *isotropic* or *anisotropic*. In an isotropic crystal, the atoms are arranged in a simple array (often cubic), and light travels through such crystals in the same manner in all directions. Calcite, quartz, and many other crystals are anisotropic; the atoms are arranged in more complicated structures. This causes light of different polarizations to travel in different directions and with different velocities, unlike what happens in an isotropic crystal.

If two polarizing filters are placed with their transmission axes perpendicular to each other, no light gets through. The light passing through one filter emerges polarized, and that direction of polarization is completely blocked by the second filter with its axis at  $90^\circ$  to the first one. However, if we put a piece of birefringent material between the two filters, some light usually gets through. The birefringent material modifies the state of polarization of the light.

The degree to which the polarization of the light is changed depends on the thickness of the material as well as on the wavelength of the light. For this reason, placing thin pieces of birefringent material between two *crossed* (axes at  $90^\circ$ ) polarizing filters will often produce a colorful display. A full analysis of the resulting colors is complex, but the colored bands give a clear indication that the inserted material is indeed birefringent.

Plastic materials provide interesting applications of these phenomena. Although plastics (polymers) are not crystalline, stressing a plastic by compressing it or pulling on it will often produce birefringence. Engineers sometimes analyze a structure they are designing by first building a small plastic model of the structure. When forces are applied to the structure, they can then see where the stress is greatest by placing the plastic model between crossed polarizers and viewing the resulting patterns (fig. 16.26).



**Figure 16.26** A plastic lens being compressed between two clamps shows stress birefringence when viewed between crossed polarizers. Diane Hirsch/Fundamental Photographs, NYC

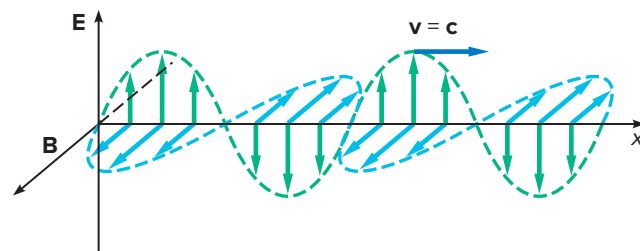
Light is polarized if the electric vector is oscillating in only one direction rather than in random directions. We can produce polarized light by passing unpolarized light through a polarizing filter. The filter transmits light with one direction of polarization and absorbs light polarized at  $90^\circ$  to the transmission axis. Reflection of light from a smooth surface of water, glass, or plastic will also produce complete or partial polarization of the reflected beam. Polarized sunglasses are designed to block the reflected beam, thus reducing glare. Light with different polarizations travels with different velocities when passing through a birefringent material. This causes colorful displays when the birefringent material is viewed through crossed polarizers.

## Summary

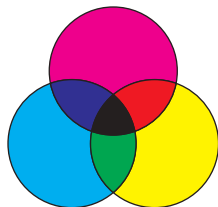
Light is an electromagnetic wave having very short wavelengths. The wave properties of light are responsible for many phenomena that produce colorful effects. Absorption, scattering, interference, diffraction, and polarization effects are all explained in terms of waves. Our color vision provides us with the ability to appreciate these phenomena.

**1 Electromagnetic waves.** James Clerk Maxwell predicted the existence of electromagnetic waves from his theory of electromagnetism. Oscillating electric charges produce variations in electric and magnetic fields that propagate through space with a

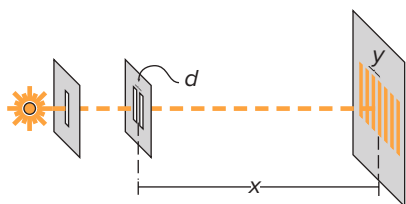
speed of  $3 \times 10^8$  m/s. Radio waves, microwaves, light, and X-rays are all forms of electromagnetic waves.



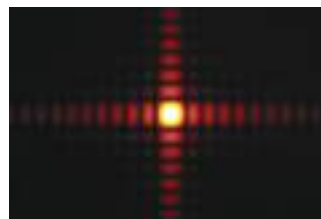
**2 Wavelength and color.** Different colors are associated with different wavelengths of light. Three types of cones in the retinas of our eyes are sensitive to different ranges of wavelength. The combined responses of these cones define the color we see and explain the rules of additive and subtractive color mixing.



**3 Interference of light waves.** Just as with other types of waves, two or more light waves can interfere constructively or destructively, depending on their relative phases. Thomas Young's double-slit experiment was the first to conclusively demonstrate interference of light. Interference of light waves reflected from thin films, such as soap film, produce colorful effects.

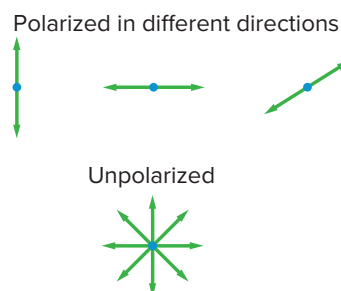


**4 Diffraction and gratings.** Interference of light coming from different parts of the same opening is called *diffraction*. Light diffracted by a single slit produces a bright central spot of light with dimmer spots of light on either side of the center. More complex diffraction patterns are produced by square or circular apertures. Diffraction gratings use interference from multiple slits to separate and measure wavelengths of light.



GIPhotoStock/Science Source

**5 Polarized light.** A polarized light wave has the electric field oscillating in just a single direction, but the electric field in an unpolarized wave oscillates in random directions. Light can be polarized by passing it through a polarizing filter or by reflecting it from a smooth surface of water, glass, or plastic. Birefringence effects are the result of light with different polarizations traveling with different speeds in an anisotropic crystal or a piece of stressed plastic.



The equations used in this chapter may seem confusing at first. If you are expected to know how to use them, you might find it helpful to try the practice problems in Connect. Look at the detailed solutions after trying them yourself.

## Key Terms

Electromagnetic waves, 332  
Electromagnetic spectrum, 334  
Infrared light, 335  
Ultraviolet light, 335  
Additive color mixing, 337

Selective absorption, 337  
Subtractive color mixing, 338  
Scattering, 339  
Thin-film interference, 341  
Diffraction, 345

Diffraction grating, 345  
Unpolarized light, 347  
Polarized light, 347  
Birefringence, 348

## Conceptual Questions

\* = more open-ended questions, requiring lengthier responses, suitable for group discussion

Q = sample responses are available in appendix D

Q = sample responses are available in Connect

- Q1. What characteristic of the electromagnetic waves predicted by Maxwell's theory led him to suggest that light might be an electromagnetic wave? Explain.
- Q2. Is the electric field associated with an electromagnetic wave constant in time? Explain.

- Q3. Is it possible for an electromagnetic wave to travel through a vacuum? Explain.
- Q4. For which of the following characteristics—speed, wavelength, and frequency—is light similar to microwaves, and for which does it differ? Explain.
- Q5. A starter's pistol is fired at the beginning of a race. If you are at the other end of the track, which will you perceive first, the sound of the pistol or the flash associated with its firing? Explain.

- Q6.** What is the color of light with a wavelength of 470 nm? Explain.
- Q7. Do the L cones in the retina of the eye respond to just a single wavelength? Explain.
- Q8. If we combine red light and green light in equal proportions, what color do we see? Explain.
- Q9.** A certain pigment absorbs green light while reflecting blue and red wavelengths. If a surface coated with this pigment is illuminated by white light, what is the color of the light reflected from this surface? Explain.
- \*Q10. A color TV uses red, green, and blue phosphors to produce the colors we see. In printing, however, we use magenta, yellow, and cyan as the primary colors. How do these two situations differ? Explain.
- Q11. Skylight is produced by the scattering of the sun's light beams in our air. Why is the color of the sky different from the color of the light of the sun itself? Explain. (See everyday phenomenon box 16.1.)
- Q12.** Why does light scattered from clouds appear white or gray? Explain. (See everyday phenomenon box 16.1.)
- Q13. Why does sunlight appear orange or red near sunset or sunrise? Explain. (See everyday phenomenon box 16.1.)
- Q14. Two waves interfere to form fringes in Young's double-slit experiment. Do these two waves come from the same light source? Explain.
- Q15.** If two waves start out in phase with each other, but one wave travels half a wavelength farther than the other before they come together, will the waves be in phase or out of phase when they combine? Explain.
- Q16. If two waves start out in phase with each other, but one wave travels two wavelengths farther than the other before they come together, will the waves be in phase or out of phase when they combine? Explain.
- Q17. When light is reflected from a thin film of oil on a water puddle, the colors we see are produced by interference. What two waves are interfering in this situation?
- Q18.** Thin-film interference occurs when one clean glass plate is placed on top of another glass plate. What does the thin film consist of in this case? Explain.
- \*Q19. Suppose that white light is reflected from a thin soap film. If the thickness is such that destructive interference is occurring for red light, what color will the film appear to be when viewed in reflected light? Explain.
- Q20. An antireflection coating on eyeglasses employs a thin-film coating on the lenses. If the coating is designed properly, does light reflected from the film undergo constructive or destructive interference? Explain. (See everyday phenomenon box 16.2.)
- Q21.** Why do lenses with a reflective coating appear to have a purplish tinge when viewed in reflected light? Explain. (See everyday phenomenon box 16.2.)
- Q22. Is diffraction the same as interference? Explain.
- \*Q23. A light beam passes through a slit and forms a spot of light on a screen at some distance from the slit. Can we make this spot of light as small as we wish by making the slit very narrow? What happens in this process? Explain.
- Q24.** What is the usual function of a diffraction grating? Explain.
- Q25. Suppose that light consisting of just two wavelengths, one blue and the other green, is passed through a diffraction grating. Which of these two colors will lie farther from the center of the screen in the first-order ( $m = 1$ ) spectrum produced by the grating? Explain.
- Q26. How does polarized light differ from unpolarized light? Explain.
- Q27.** Can a wave on a guitar string be polarized? Explain.
- Q28. If you pass an unpolarized light beam through a polarizing filter, will the light beam emerging from the filter be weaker or stronger than the incoming beam? Explain.
- Q29. Besides passing light through a polarizing filter, is there any other way that unpolarized light can become polarized? Explain.
- Q30.** If you use polarized sunglasses to eliminate glare from water surfaces, should the axis of transmission of the polarizer in the sunglasses be oriented in the vertical direction or in the horizontal direction? Explain.
- Q31. A double image of a dot is seen when viewing the dot through a calcite crystal. Is there any difference in the polarization of the light associated with these two images? Explain.
- Q32. Birefringence is associated with anisotropic crystals but plastics are not usually crystalline. Is there any way in which a plastic material can exhibit birefringence? Explain.

## Exercises

- E1. Microwaves used in microwave ovens often have a wavelength of about 12 cm. What is the frequency of these waves?
- E2. What is the wavelength of the radio waves from a station broadcasting at 88.1 MHz ( $88.1 \times 10^6$  Hz)?
- E3. What is the frequency of blue light waves with a wavelength of 470 nm?
- E4. In general, X-rays have wavelengths between 10 nm and 0.01 nm. For an X-ray with a wavelength of 8 nm, what is the corresponding frequency?
- E5. Light with a wavelength of 700 nm ( $7 \times 10^{-7}$  m) is incident upon a double slit with a separation of 0.3 mm ( $3 \times 10^{-4}$  m). A screen is located 1.5 m from the double slit. At what distance from the center of the screen will the first bright fringe beyond the center fringe appear?

- E6. For the same conditions described in exercise 5, at what distance from the center of the screen will the fourth dark fringe appear?
- E7. An orange fringe produced by double-slit interference lies 1.7 cm from the center of a screen placed 0.8 m from the double slit. If the screen is moved back, so that it is now a distance of 3.2 m from the double slit, how far from the center of the screen will this orange fringe lie?
- E8. Violet light of 425 nm is reflected from a thin film of air between two glass plates. The thickness of the film is 1.70  $\mu\text{m}$  (1700 nm).
- How much farther does the light reflected from the bottom surface of the film travel than that reflected from the top surface?
  - How many wavelengths of light does this represent?
- E9. An antireflection coating is designed with a thickness of a quarter of the wavelength of the light traveling in the film.
- How many wavelengths farther does the light reflected from the bottom surface of the coating travel than that reflected from the top surface?
  - Does this produce constructive or destructive interference?
- E10. Light with a wavelength of 480 nm ( $4.8 \times 10^{-7}$  m) strikes a single slit that is 0.6 mm ( $6 \times 10^{-4}$  m) wide. The diffraction pattern produced by the slit is observed on a wall a distance of 2.5 m from the slit.
- What is the distance from the center of the pattern to the first dark fringe?
  - How wide is the central bright fringe of this diffraction pattern?
- E11. When illuminated with light of 700 nm ( $7 \times 10^{-7}$  m), the first dark fringe produced by a single slit lies a distance of 1.6 cm from the center of the screen placed 2.5 m from the slit. How wide is the slit?
- E12. A diffraction grating has 2200 slits or lines ruled in a space of 3.1 cm. What is the distance  $d$  between adjacent slits?
- E13. Light of 436-nm ( $4.36 \times 10^{-7}$  m) wavelength from a mercury lamp passes through a diffraction grating with a spacing between adjacent slits of 0.007 mm ( $7 \times 10^{-6}$  m). A screen is located a distance of 1.5 m from the grating.
- How far from the center of the screen will the first-order bright fringe lie?
  - How far from the center of the screen will the second-order bright fringe lie?
- E14. When passed through a diffraction grating with a slit spacing of 0.004 mm ( $4 \times 10^{-6}$  m), the first-order fringe for light of a single wavelength lies a distance of 27 cm from the center of a screen located 1.9 m from the grating.
- What is the wavelength of the light?
  - What is the color of the light?

## Synthesis Problems

- SP1. The visible spectrum of colors ranges from approximately 380 nm in wavelength at the violet end to 750 nm at the far red end.
- What are the frequencies associated with these two wavelengths?
  - When light passes into glass, the speed of light is reduced to  $v = c/n$ , where  $n$  is called the *index of refraction*. For many types of glass or plastic,  $n$  is approximately 1.5. What is the approximate speed of light in glass?
  - If the frequency of light does not change when light enters glass, the wavelength must change to account for the reduction in speed. What are the wavelengths for the two ends of the visible spectrum in glass?
- SP2. Light with a wavelength of 580 nm ( $5.8 \times 10^{-7}$  m) passes through two slits separated by just 0.044 mm ( $4.4 \times 10^{-5}$  m). A fringe pattern is observed on a screen placed 1.3 m from the double slit.
- How far from the center of the screen will the first bright fringe appear on either side of the central fringe?
  - Where will the second bright fringe appear on either side?
  - At what distance from the center of the screen will the first dark fringe appear on either side?
  - Sketch a diagram showing the positions of the seven central bright fringes (the center fringe and three fringes on either side of the center fringe). Clearly indicate the distance of each fringe from the center of the screen.
- SP3. Standing waves (see section 15.3) can be formed by reflecting light from a mirror and allowing the reflected wave to interfere with the incoming wave. Suppose we do so using light with a wavelength of 600 nm ( $6 \times 10^{-7}$  m). Assume there is a node at the mirror surface.
- How far from the mirror will the first antinode lie?
  - What is the separation distance between adjacent antinodes (right fringes) as we move away from the mirror?
  - Will it be easy to observe the dark and bright fringes associated with the nodes and antinodes of the standing wave? Explain.
- SP4. A certain soap film has an index of refraction (see synthesis problem 1) of  $n = 1.4$ . This implies that the wavelength of light in the film is shorter than in air by a factor of  $1/n$ . The index of refraction of air is approximately 1.0, so there is little difference between the wavelength in air and that in a vacuum.
- If light with an air or vacuum wavelength of 693 nm enters a soap film, what is the wavelength of this light in the film?
  - If the film is 1980 nm thick, how many wavelengths farther does the wave reflected from the bottom surface of the film travel than that reflected from the top?
  - Would you be surprised to find that this thickness produces destructive interference for reflected light?\*

\*The two waves are out of phase because of a phase difference introduced by the reflection process itself—the wave reflected from the top surface is shifted in phase, while that reflected from the bottom surface is not. The path difference between the two waves produces no phase change, but the reflection process does.

## Home Experiments and Observations

- HE1. If you have access to a color ink jet printer, print a color test pattern with the printer. View the test pattern through a strong magnifying glass.
- Can you see the individual colored dots that form the colors on the page? Which of the colors in the test pattern appear to be made up of just single colored dots?
  - With the help of the magnifying glass, describe how the other colors in the test pattern are produced.
  - Use the magnifying glass to observe the lines on the screen of a color TV (*with the set turned off!*). What colors do you observe? How do these colors differ from those used in color printing?
- HE2. It is a simple matter to produce soap films that demonstrate thin-film interference phenomena. Place a few drops of liquid dishwashing detergent in a shallow bowl and add enough water to form a reasonably fluid solution. Bend a piece of wire into a closed loop, leaving a small length to serve as a handle. (Alternatively, you can purchase bubble-making solution with the wire loop included for a very small cost.)
- Dip the loop in the soap solution to form a soap film in the plane of the loop. Reflect light from a desk lamp from the film. Describe the colored patterns you see.
  - If you hold the loop in a vertical plane, the colors should settle into a pattern of horizontal bands. Sketch the bands you see, indicating both their color and their width. Explain why we get horizontal bands.
  - Try illuminating your soap film first with a frosted incandescent lamp and then with a fluorescent lamp. Describe the differences you see.
- HE3. Find two flat glass plates (microscope slides will work). Wipe the glass plates clean and place one on top of the other. View the plates in reflected light from the overhead lighting in your room.
- Describe the pattern of light and dark fringes that you see. Are there any colors associated with these fringes?
  - Place a very thin object, such as a human hair, between the two plates near one end. Does this change the fringe pattern? Can you explain the pattern you see?
- HE4. View a distant point light source (such as a distant street-light or a bright star) at night through a window screen.
- Sketch the appearance of the light when viewed through the screen. How does this differ from the appearance of the light when viewed directly (not looking through the screen)?
  - Contrast your observations with the square-aperture pattern pictured in figure 16.19. What similarities and differences can be identified?
- HE5. Locate two polarizing filters. (Your physics instructor is probably your best source. Most sunglasses are not polarizers.)
- View the blue sky through one polarizer while rotating the polarizer around your line of sight. What changes in intensity do you observe?
  - Place one polarizer on top of the other and rotate one of them. When the polarizers are crossed (axes at  $90^\circ$ ), no light should get through. How does the transmitted light vary as you rotate the second polarizer?
  - Place various plastic items (rulers, protractors, plastic spectacle lenses, etc.) between crossed polarizers. Describe the patterns you observe.
- HE6. Find a laser pointer and a couple of pieces of aluminum foil.
- Take a piece of the aluminum foil, poke a small hole in it with a pin, and observe the pattern you see when shining a laser pointer through the hole. Describe the pattern.
  - Make a different-sized hole and compare the pattern you see. Describe the differences.



# CHAPTER 17

Don Farrall/Getty Images

## Light and Image Formation

### Chapter Overview

Our main goal in this chapter is to provide an understanding of the laws of reflection and refraction and how they are used to explain image formation. To do this, we need to discuss the relationship between waves and rays and to show how rays can be traced to define and locate images. In the process of exploring image formation, we examine the behavior of mirrors and lenses and the workings of simple optical instruments, such as cameras, magnifiers, microscopes, and telescopes.

### Chapter Outline

- 1 Reflection and image formation.** What is the relationship between rays and waves? What is the law of reflection, and how are images formed by a plane mirror?
- 2 Refraction of light.** How does the law of refraction describe the bending of light rays when they pass from one medium to another? How can we explain the separation of colors by a prism?
- 3 Lenses and image formation.** How can the law of refraction explain image formation by simple lenses? How do positive lenses differ from negative lenses?
- 4 Focusing light with curved mirrors.** How can curved mirrors be used to focus light? How do concave mirrors differ from convex mirrors in their image-forming properties?
- 5 Eyeglasses, microscopes, and telescopes.** How do eyeglasses help us to see better? How can lenses and mirrors be combined to produce microscopes and telescopes?

**H**ave you ever looked in a mirror and wondered how you are able to stare yourself in the face? How does that early morning, mussed-up face pretending to be you appear behind the glass plate (fig. 17.1)? You know that you are seeing an image that depending on the quality of the mirror, may or may not be an accurate reflection of reality. You are free to believe what you wish.

You may also wear eyeglasses, and you probably have used optical instruments that incorporate lenses, like binoculars, telescopes, and microscopes. Images formed by mirrors involve the reflection of light. Images formed by lenses involve the refraction, or bending, of light. Both reflection and refraction are at work in producing rainbows.

In chapter 16, we introduced the idea that light is an electromagnetic wave and described the general features of these waves. How are such waves involved in the formation of images in a mirror, in a microscope, or in your eye itself? What are the basic principles of image formation? Can we predict where the images will be formed and how they will appear?

Such questions lie in the realm of **geometric optics**, in which the behavior of light waves is described by using rays that are perpendicular to the wavefronts. The laws of reflection and refraction are the basic principles of geometric optics. These laws allow us to trace the paths of light rays and to



**Figure 17.1** An early morning look in the mirror. How does that discouraging image get there? Bob Coyle/McGraw-Hill Education

predict how and where images will be formed. In contrast, **physical optics** (chapter 16) treats phenomena, such as interference and diffraction, that involve the wave aspects of light more directly.

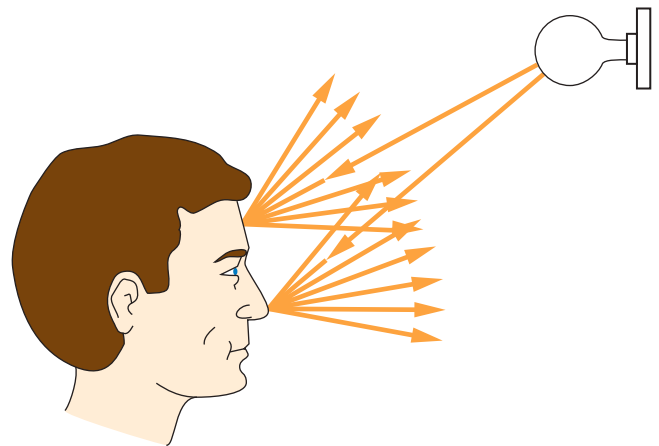
## 17.1 Reflection and Image Formation

How is your image in the bathroom mirror produced? You know that light is involved somehow, as you can easily verify by turning off the bathroom light. If the room is completely dark, the image disappears, only to reappear instantly when the light is turned back on. Light waves from the bathroom light must bounce off your face, travel from there to the mirror, and then reflect back to your eyes. How does this process create the image we see?

### How are light rays related to wavefronts?

If we consider just one point on your face and trace what happens to the waves that are reflected from that point, we get a clearer idea of what is happening. Since the skin on your face is somewhat rough (at least on a microscopic scale), light that reaches your face is reflected, or *scattered*, in all directions from any given point. The tip of your nose, for example, behaves as though it were a source of light waves that spread out uniformly from that point (fig. 17.2). These waves are like the ripples that spread on a pond when a rock is dropped into the water.

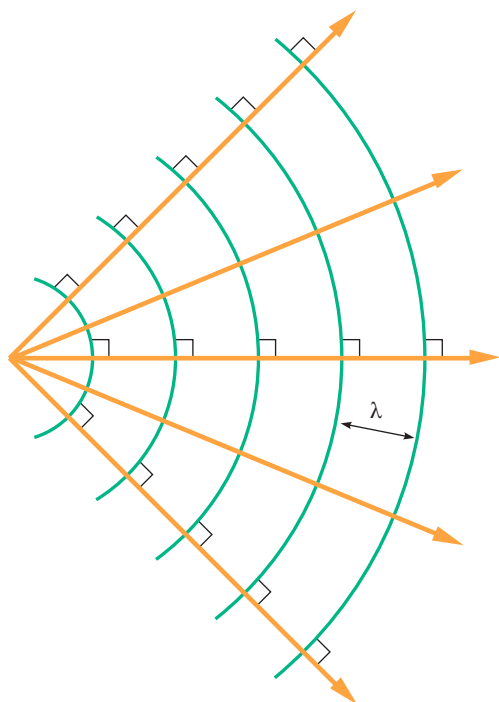
The light waves scattered from your face are electromagnetic waves, not waves of water, but they have crests (where the electric and magnetic fields are the strongest) that move outward from the source point just as water waves do. If we



**Figure 17.2** Any point on your face acts as a secondary source of light rays that are reflected in all directions from that point.

connect the points on the wave that are all at the same point in their cycle, we define a **wavefront**. We often choose the crest of the wave (the point of maximum positive amplitude) for this purpose, since it is clearly visible in water waves. The next wavefront behind the leading one is the next point at which the waves are at their crest, and it is separated from the previous wavefront by a distance of one wavelength, as in figure 17.3. For light waves, these wavefronts move away from the source point at the speed of light.





**Figure 17.3** Light rays (shown as straight lines) are drawn so that they are everywhere perpendicular to the wavefronts (shown as arcs). If the waves travel with uniform speed, the rays are straight lines.

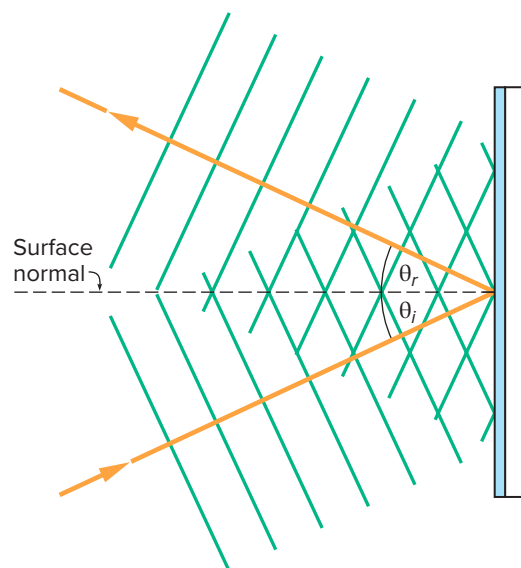
We could describe almost everything that happens to these waves by tracing what happens to the wavefronts. It is easier, however, to examine their behavior using rays perpendicular to the wavefronts. If the waves are traveling in the same medium (air, for example), the wavefronts move forward uniformly and the resulting rays are straight lines (fig. 17.3). These rays are easier to draw than the curved wavefronts and can be traced more readily.

Because each point on your face scatters light in all directions, these points act as sources of diverging light rays, as in figure 17.2. The light rays travel from your face to the mirror, where they are reflected in a predictable manner because of the smoothness of the mirror. Your eyes are receiving light from the lightbulb, but that light has been reflected by both your face and the mirror before getting back to your eyes.

### What is the law of reflection?

What happens when light rays and wavefronts strike a smooth reflecting surface, like a flat mirror? The waves are reflected, and after reflection, they travel away from the mirror with the same speed that they had before reflection. Figure 17.4 depicts this process for plane wavefronts (no curvature) that are approaching the plane mirror at an angle rather than head-on.

Because the wavefronts approach the mirror at an angle, some parts of the wavefront are reflected sooner than others



**Figure 17.4** Plane light waves approaching a mirror at an angle travel with the same speed both before and after striking the mirror. The angle of reflection equals the angle of incidence.

(fig. 17.4). These wavefronts now travel away from the mirror with the same spacing and speed but in a new direction. The angle between the wavefront and the mirror is the same, however, for the emerging wave. Because the outgoing wavefronts travel at the same speed and cover the same distance in a given time as the incoming waves, this produces equal angles between the wavefronts and the surface of the mirror.

This result is usually stated using rays. The angle that a ray makes to a line drawn perpendicular to the surface is the same angle that the wavefront (which is perpendicular to the ray) makes to the surface of the mirror. Using the word *normal* to mean *perpendicular* (as in chapter 4 when we discussed normal forces), we call the line drawn perpendicular to the surface of the mirror the **surface normal**. The equal angles the wavefronts make to the mirror dictate that the angle the reflected ray makes to the surface normal is equal to the angle that the incoming, or *incident*, ray makes to the surface normal (fig. 17.4).

What we have just described is the **law of reflection**, which can be stated concisely like this:

When light is reflected from a smooth reflecting surface, the angle the reflected ray makes with the surface normal is equal to the angle the incident ray makes with the surface normal.

In other words, the angle of reflection ( $\theta_r$  in fig. 17.4) is equal to the angle of incidence ( $\theta_i$ ). The reflected ray also lies within the plane defined by the incident ray and the surface normal. It does not deviate in or out of the plane of the page in our diagram.

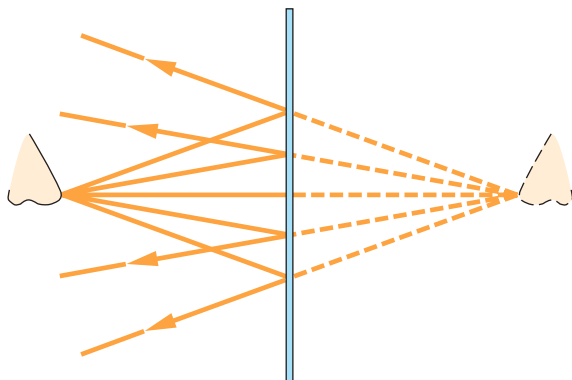
### How are images formed by a plane mirror?

How can the law of reflection help us to explain how an image is formed in a plane mirror? What happens to the light rays that are scattered from your nose? Tracing these rays from their origin at the nose and following them through reflection from the mirror using the law of reflection shows what happens to individual rays (fig. 17.5).

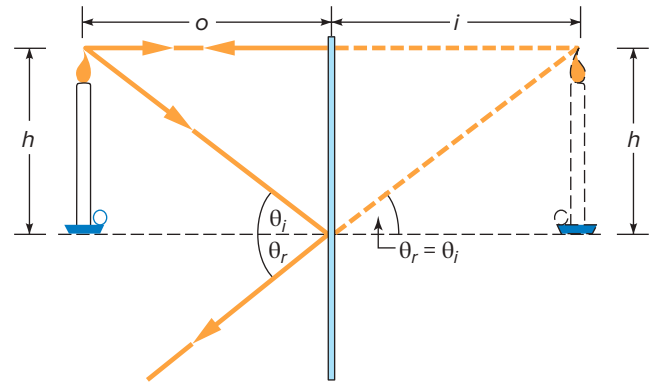
If we extend the reflected rays backward from the mirror, they intersect at a point behind the mirror, as shown. As your eye collects a small bundle of reflected rays, it perceives an image that appears to lie at this point of intersection. In other words, as far as your eye can tell, these light rays are coming from that point. You see the tip of your nose as lying behind the mirror. The same argument holds for any other point on your face—they all seem to lie behind the mirror.

Using simple geometry, you can see that the distance of this image behind the mirror (measured from the mirror surface) is equal to the distance of the original object from the front of the mirror. These equal distances follow from the law of reflection, as figure 17.6 illustrates. Here we have taken just two rays coming from the top of a candle and traced them as before. The ray that comes into the mirror in the horizontal direction, and is perpendicular to the mirror, is reflected back along the same line. The angle of incidence for this ray is zero—so is the angle of reflection.

The other ray is shown as being reflected from a point on the mirror even with the base of the candle. This ray is reflected at an angle equal to its angle of incidence. When these two rays are extended backward, their intersection locates the image position. Any other rays traced from the top of the candle would also appear to come from this point. The two rays shown form identical triangles on either side of the mirror (fig. 17.6). Because the angles are equal, and the short sides of both triangles are equal to the height of the candle, the long sides of these identical triangles must also be equal. The image is therefore located



**Figure 17.5** A few rays are traced from the tip of the nose to show their reflection from the mirror. They diverge after reflection as though they were coming from a point behind the mirror.



**Figure 17.6** Two light rays coming from the top of the candle appear to diverge after reflection from a point as far behind the mirror as the candle is in front of the mirror.

behind the mirror at an *image distance*,  $i$ , equal to the *object distance*,  $o$ , of the candle from the front of the mirror.

Because we all have access to plane mirrors, you can verify some of these ideas by observing your own image, and images of other objects, as you move before the mirror. The mirror does not have to be as tall as you, for example, for you to see your entire height. Do you see more of you as you move toward the mirror or away from the mirror? What about other objects? Where must you be positioned to see various other objects in the room? Can you explain these observations by the law of reflection and by which rays reach your eyes?

The image formed by a plane mirror is called a *virtual image*, because the light never actually passes through the point where the image is located. In fact, the light never gets behind the mirror at all—it just appears to come from points behind the mirror as it is reflected. The image can also be characterized as being upright (right side up) and as having the same size as the object (not magnified). There is a reversal, however, of front to back that makes the right hand of your mirror image appear to be your left hand, and vice versa. Take another look. You see such images every day, but you probably have not given them much thought.

Light rays are drawn perpendicular to the wavefronts. Tracing these rays often provides an easier way of seeing what happens to light than following the wavefronts themselves. The law of reflection states that when light is reflected from a smooth reflecting surface, the angle of reflection equals the angle of incidence (both measured from the surface normal). The image formed by a plane mirror lies at the point from which the light rays appear to be diverging after reflection, which is as far behind the mirror as the object is in front of the mirror.

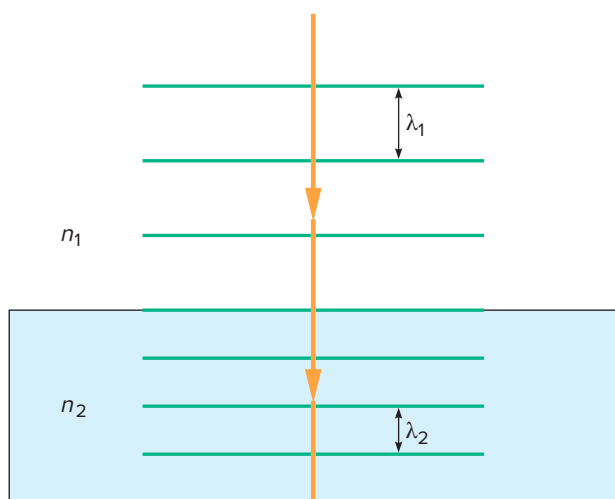
## 17.2 Refraction of Light

The most familiar images are those formed by plane mirrors. Images can be formed in other ways, though, with prisms, lenses, or maybe just a tank of water. These examples all involve substances that are transparent to visible light. What happens to light rays when they encounter the surface of a transparent object? Why do we get misleading impressions about the location of underwater objects? The *law of refraction* helps us answer these questions.

### What is the law of refraction?

Suppose light waves encounter a plane surface of a piece of glass after traveling initially through air. What happens to these waves as they pass into the glass and continue traveling through the glass? Experimental measurements have shown that the speed of light in glass or water is less than the speed of light in a vacuum or air. (The speed of light in air is very close to its speed in a vacuum.) The distance between wavefronts (the wavelength) will be shorter in glass or water than in air (fig. 17.7), because the waves travel a smaller distance in one cycle, given their smaller speed.

The difference in the speed of light in different substances is usually described by a quantity called the **index of refraction**, represented by the symbol  $n$ . The index of refraction is defined as the ratio of the speed of light  $c$  in a vacuum to the speed of light  $v$  in some substance,  $n = c/v$ . The speed of light  $v$  in the substance is then related to the speed of light  $c$  in a vacuum by  $v = \frac{c}{n}$ .

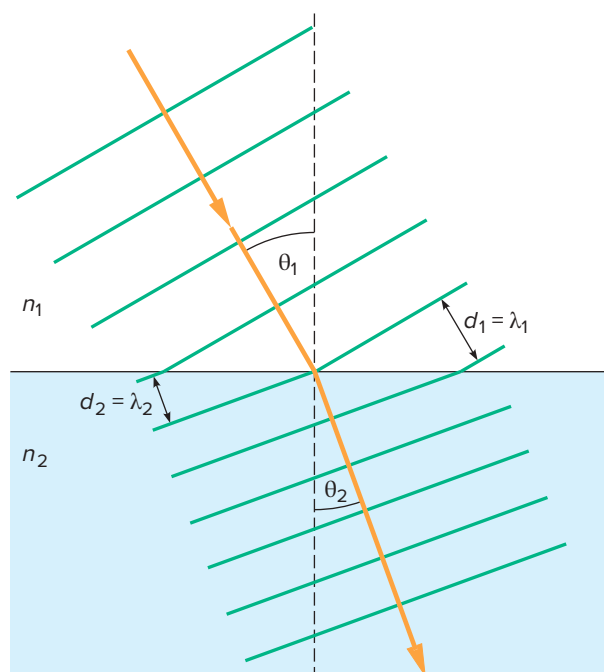


**Figure 17.7** The wavelength of light waves traveling from air into glass is shorter in the glass than in air because of the smaller speed of light waves in glass.

In other words, to find the speed of light in some transparent material, we divide the speed of light in a vacuum ( $c = 3 \times 10^8$  m/s) by the index of refraction of that material. Typical values for the index of refraction of glass are between 1.5 and 1.6, so the speed of light in glass is approximately two-thirds the speed of light in air.

What effect does this reduction in speed and wavelength have on the direction of light rays as they pass into glass? If we consider wavefronts and their corresponding rays approaching the surface at an angle, as in figure 17.8, we can see that the rays will bend as the waves pass from air to glass. The bending occurs because the wavefronts do not travel as far in one cycle in the glass as they do in air. As the diagram shows, the wavefront halfway into the glass travels a smaller distance in glass than it does in air, causing it to bend in the middle. Thus, the ray, which is perpendicular to the wavefront, is also bent. The situation is like a marching band marching onto a muddy field at an angle to the edge of the field. The rows bend as their speed is reduced by the mud.

The amount of bending depends on the angle of incidence and on the indices of refraction of the materials involved, which determine the change in speed. A larger difference in speed will produce a greater difference in how far the wavefronts travel in the two substances. A larger difference in indices of refraction of the two substances therefore produces a larger bend in the wavefront and ray.



**Figure 17.8** Wavefronts approaching a glass surface at an angle to the surface are bent as they pass into the glass. The angle of refraction,  $\theta_2$ , is less than the angle of incidence,  $\theta_1$ . ( $n_2$  is larger than  $n_1$ .)

The bending described by the **law of refraction** can be stated in qualitative\* terms in this way:

When light passes from one transparent medium to another, the rays are bent toward the surface normal (the axis drawn perpendicular to the surface) if the speed of light is smaller in the second medium than in the first. The rays are bent away from this axis if the speed of light in the second medium is greater than in the first.

If the angles are small, less than  $15^\circ$  or so, the quantitative statement of the law of refraction takes a simple form:

$$n_1\theta_1 \cong n_2\theta_2$$

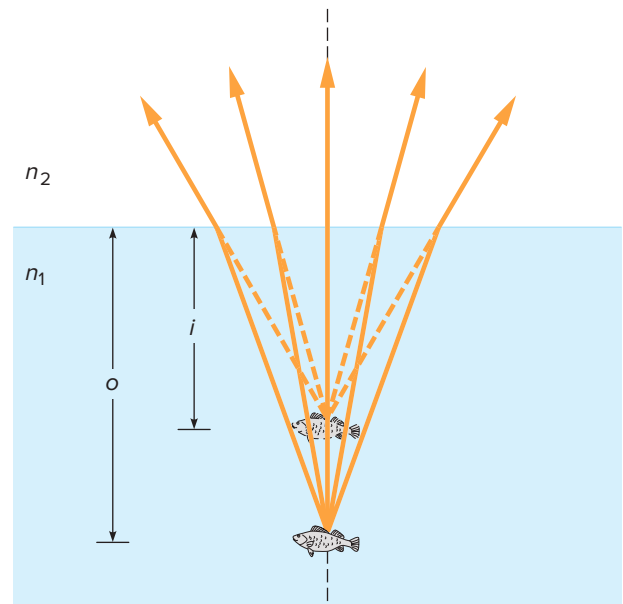
The product of the index of refraction of the first medium times the angle of incidence is *approximately* equal to the product of the index of refraction of the second medium times the angle of refraction. As the index of refraction of the second medium increases, the angle of refraction must decrease, which means that the ray is bent closer to the axis (the surface normal) for larger indices of refraction.

For light waves traveling from glass to air, the bending is in the opposite direction: The rays are bent away from the surface normal, according to the law of refraction. Simply reversing the directions of the rays and wavefronts in figure 17.8 will make this clear. The increase in speed as the wave travels from glass to air causes the ray to bend away from the axis.

### Why do underwater objects appear to be closer than they are?

The bending of light rays at the interface of two transparent substances is responsible for some deceptive appearances. Suppose, for example, that you are standing on a bridge over a stream, looking down at a fish. Water has an index of refraction of about 1.33, and air has an index of refraction of approximately 1. Light traveling from the fish to your eyes is bent away from the surface normal, as in figure 17.9.

This bending of the light rays coming from the fish causes them to diverge more strongly in air than when they were traveling in the water. If we extend these rays backward, we see that they now appear to come from a point closer to the surface of the water than their actual point of origin (fig. 17.9). Because this is true for any point on the



**Figure 17.9** Light rays coming from the fish are bent as they pass from the water to air, so that the rays appear to diverge from a point closer to the surface.

fish, the fish appears to be closer to the surface than it actually is. If you were attempting to shoot the fish (illegal in most places), you would likely miss unless you were shooting straight down.

The apparent distance of the fish beneath the surface can be predicted from the law of refraction if we know the actual distance. The argument involves some geometry and the assumption that the angles of incidence and refraction are small. We find that the apparent distance as seen from the air (the image distance  $i$ ) is related to the actual distance under water (the object distance  $o$ ) and the indices of refraction by

$$i = o \left( \frac{n_2}{n_1} \right)$$

where the index of refraction of the second medium  $n_2$  is that of air ( $n_a = 1$ ) and the index of the first medium  $n_1$  is that of water ( $n_w = 1.33$ ). The image distance is therefore less than the actual distance, as figure 17.9 clearly illustrates. If the fish is actually 1 m below the surface, its apparent distance below the surface is

$$i = 1 \text{ m} \left( \frac{1}{1.33} \right) = 0.75 \text{ m}$$

This apparent location of the fish is the position of the *image* of the fish. Light rays scattered from the fish seem to come from this point rather than from the actual position of the fish. We see a virtual image, like the image seen in a mirror, because the light rays do not actually pass through the image position. They only appear to come from that point. If instead we view an object in air from under water,

\*The law of refraction is stated quantitatively using the trigonometric function, the sine, which will only be familiar if you have some background in trigonometry. It is usually written in symbolic form as  $n_1 \sin \theta_1 = n_2 \sin \theta_2$ , where  $n_1$  and  $n_2$  are the indices of refraction of the two media, and  $\theta_1$  and  $\theta_2$  are the angle of incidence and the angle of refraction (fig. 17.8).

### Example Box 17.1

#### Sample Exercise: Viewing an Object from under Water

A girl swimming under water views a dragonfly hovering over her in the air. The dragonfly appears to be about 60 cm above the water surface. What is the actual height of the dragonfly above the water?

Because the object (the dragonfly) is in air, the light is traveling initially in air, so

$$\begin{aligned}
 n_1 &= 1.00 & i &= o \frac{n_2}{n_1} \\
 n_2 &= 1.33 & o &= i \frac{n_1}{n_2} \\
 i &= 60 \text{ cm} & & \\
 & & &= 60 \text{ cm} \frac{1}{1.33} \\
 & & &= 45 \text{ cm}
 \end{aligned}$$

(The object is actually closer to the water surface than it appears to be.)



**Figure 17.10** When viewed from above, a straw appears to bend when part of it is above water and the rest below. Viewed from the side, the straw is magnified. *Lisa Burgess/McGraw-Hill Education*

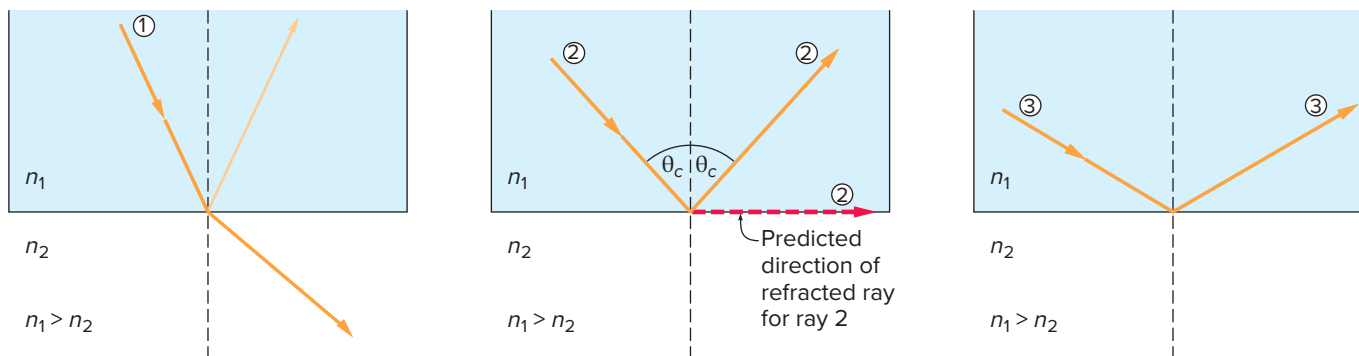
the image appears farther away from the water surface than the actual object position (example box 17.1).

The misleading position of objects viewed under water is something we observe daily but often fail to notice simply because the experience is so common. A straight stick or rod seems to bend or break if part of it is above water and the rest below. When viewed from the top, each point of the underwater object appears to lie closer to the surface than its actual distance. A straw or spoon in a glass of water or other beverage likewise appears to bend, as in figure 17.10. We are used to the deception and seldom give it a second thought.

### Total internal reflection

Another interesting phenomenon occurs when light rays travel from either water or glass to air. As we have already indicated, the light rays bend away from the axis as they pass into the medium with the lower index of refraction (air, in these examples). What happens, though, if the rays are bent so much that the angle of refraction is 90°? The angle of refraction cannot be any larger and still result in rays passing into the second medium.

This situation is depicted in figure 17.11. As the angle of incidence for rays traveling in the glass gets larger, so does the angle of refraction (ray 1). Ultimately, we reach the point at which the angle of refraction is 90° (ray 2). At this point, the refracted ray would just skim the surface as it emerged



**Figure 17.11** When light travels from glass to air, the angle of incidence that would produce an angle of refraction of 90° (ray 2) is called the critical angle  $\theta_c$ . Rays incident at equal or greater angles than  $\theta_c$  are totally reflected.

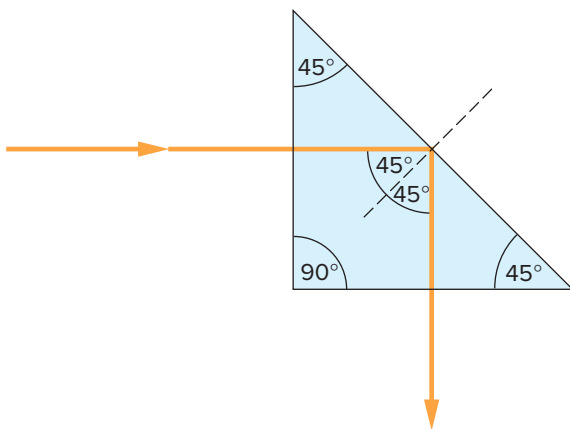
from the glass. For any angle of incidence inside the glass larger than this angle (ray 3), the ray does not escape the glass at all—it is reflected instead. The angle of incidence for which the angle of refraction is  $90^\circ$  is called the *critical angle*  $\theta_c$ .<sup>\*</sup> Rays incident at angles greater than the critical angle are reflected back inside the glass and obey the law of reflection rather than the law of refraction.

This phenomenon is called *total internal reflection*. For angles equal to or greater than the critical angle, 100% of the light is reflected inside the material with the larger index of refraction. Under these conditions, the glass-air interface makes an excellent mirror. For glass with an index of refraction of 1.5, the critical angle is approximately  $42^\circ$ . Glasses with larger indices of refraction have even smaller critical angles. A prism cut with two  $45^\circ$  angles, as in figure 17.12, can be used as a reflector. Light incident perpendicular to the first surface strikes the long surface at an angle of incidence of  $45^\circ$ , which is greater than the critical angle. It is totally reflected at this surface, so the surface acts as a plane mirror.

### How do prisms bend light, and what is dispersion?

You know that white light can be separated into different colors by a prism, producing an effect like a rainbow. How do we get the colors of the rainbow when we start with ordinary white light?

The index of refraction of a material varies with the wavelength of light: Different wavelengths are bent by different amounts. The wavelength, in turn, is associated with the color we perceive, as discussed in chapter 16. Red light, at one end of the visible spectrum, has longer wavelengths and lower frequencies than violet light, at the opposite end of the spectrum. The index of refraction for violet light is greater than for red light for most types of glass and other transparent substances, like water. Violet light is bent more



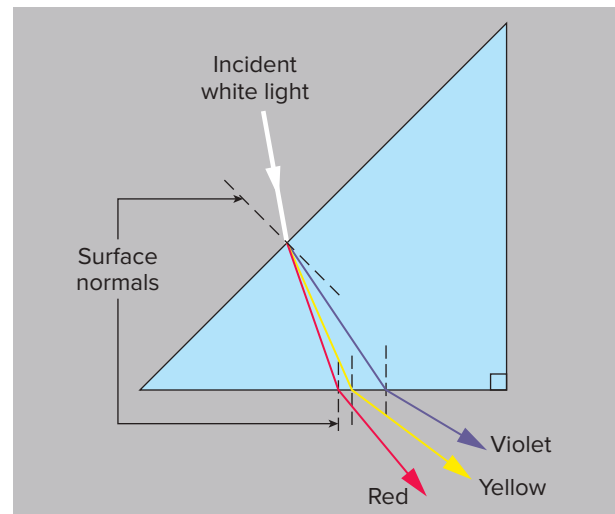
**Figure 17.12** A prism cut with two  $45^\circ$  angles can be used as a mirror, because the light is totally reflected.

<sup>\*</sup>From the law of refraction,  $\sin \theta_c = n_2/n_1$ , where  $n_2$  must be less than  $n_1$  for the expression to be valid.

than red light, and the intermediate wavelengths associated with the colors green, yellow, and orange are bent by intermediate amounts.

When light passes through a prism at an angle, the light is bent as it enters the prism and again as it leaves, as in figure 17.13. The rays bend toward the surface normal as they enter the prism, and away from the normal at the second surface, consistent with the law of refraction. Because the index of refraction varies for different wavelengths, the violet rays are bent the most and lie at the top of the resulting spectrum of colors, as figure 17.14 shows.

This variation of index of refraction with wavelength is called **dispersion**, and it exists for all transparent materials, including water, glass, and clear plastics. Dispersion is responsible for the colors you see when light passes through a fish tank or around the edges of a lens, as in an overhead



**Figure 17.13** Light rays passing through a prism are bent at both surfaces, with violet light being bent more strongly than red.



**Figure 17.14** White light incident on one side of the prism emerges as a spectrum of different colors because of dispersion.  
Don Farrall/Getty Images

## Everyday Phenomenon

## Box 17.1

## Rainbows

**The Situation.** Figure 1.1 in chapter 1 is a photograph of a rainbow. We have all seen such sights and been awed by their beauty. We know that rainbows occur when the sun is shining and it is raining nearby. If conditions are right, we can see an entire semicircular arc of color with red on the outside and violet on the inside. Sometimes, we can also see a fainter bow of color forming a secondary arc outside of the primary one. The colors in the secondary rainbow are in reverse order of those in the primary rainbow, as the photo shows.

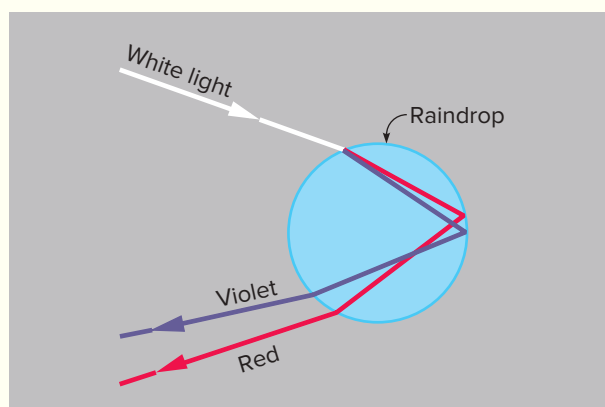
How is a rainbow formed? What conditions are necessary for observing a rainbow? Where should we look? Can the laws of



The primary rainbow has red on the outside and violet on the inside. The secondary rainbow, sometimes visible, has the colors reversed.  
*Robbie George/National Geographic/Getty Images*

reflection and refraction be used to explain this phenomenon? We can now address these questions, some of which were first raised in chapter 1.

**The Analysis.** The secret to understanding a rainbow lies in considering what happens to light rays when they enter a raindrop, as in the first drawing. When a light ray strikes the first surface of the raindrop, some of it is refracted into the drop.



Light rays entering a raindrop are refracted by different amounts at the first surface, reflected at the back surface, and refracted again as they leave. The steeper angle for the emerging red rays dictates that these rays will reach the viewer from raindrops higher in the sky, placing red at the top of the rainbow.

projector. It is also responsible for the beautiful displays of color seen in rainbows, as explained in everyday phenomenon box 17.1.

Light rays are bent when they pass from one transparent substance to another, because the speed of light changes at the boundary between the two substances. The law of refraction describes how much bending occurs and whether the bending is toward or away from the surface normal. Because of this bending, the image of an underwater object appears to lie closer to the surface of the water than the actual position of the object. For light traveling initially inside glass or water, there is a critical angle of incidence beyond which the light is totally reflected rather than being refracted. The index of refraction varies with wavelength, producing the dispersion of colors we see when light passes through a prism.

## 17.3 Lenses and Image Formation

We encounter the images formed by mirrors daily and seldom give them a second thought. We may be even less aware of the images formed by lenses, although many of us have lenses hanging on our noses or sitting on our eyeballs in the form of corrective eyeglasses or contact lenses. We also encounter lenses in cameras, overhead projectors, opera glasses, and simple magnifying glasses.

How do lenses form images? Lenses are usually made of glass or plastic, so the law of refraction governs their behavior. The bending of light rays as they pass through a lens is responsible for the size and nature of the images formed. We can understand the basics of this process by tracing what happens to just a few of these rays.

### Tracing rays through a positive lens

A lens shaped so that both sides are spherical surfaces with the convex sides facing out is pictured in figure 17.15.

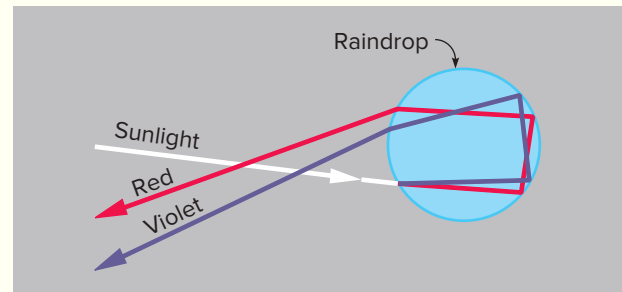
Because the amount of bending depends on the index of refraction, which depends on the wavelength of the light, violet light is bent more than red light at this first surface. This effect is the same as the dispersion that occurs when light passes through a prism.

After being refracted at the first surface, the light rays travel through the drop and strike its back surface, where they are partially reflected. Some of the light passes out of the drop, and some is reflected back toward the front surface as shown. At the front surface, the rays are refracted again, causing more dispersion as the rays leave the drop.

It may seem paradoxical that red light, which is bent the least in the refractions, is actually diverted through a larger angle than violet light in its overall path through and back out of the raindrop. The reason can be understood from the first drawing. The smaller bending at the first surface causes the red rays to strike the back surface of the drop at a greater angle of incidence than for the violet rays. The red rays are reflected through a greater angle, according to the law of reflection. This larger angle of reflection dominates in determining the overall deflection of the ray.

When we view a rainbow, the sun must be behind us, because we are observing reflected rays. We see different colors at different points in the sky because, for a given color, the raindrops must be at the appropriate height for the light rays to reach our eyes. Because red rays are deviated the most, we see red light reflected from raindrops at the top of the rainbow or at the greatest angle from the center of the arc. Violet light comes to us from raindrops lying at smaller angles. The other colors lie in between, producing the colorful arc we see.

The secondary rainbow, which is usually much fainter than the primary rainbow, is produced by a double reflection inside



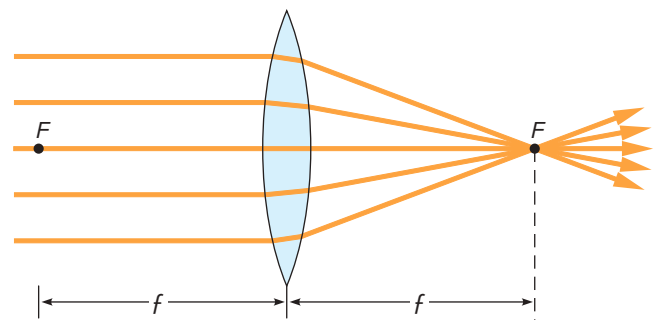
Light rays entering near the bottom of the first surface of a raindrop may be reflected twice before reemerging. These rays produce the secondary rainbow. Its steeper angle puts violet at the top of the secondary rainbow.

the raindrops, as the second drawing shows. Light rays entering near the bottom of the first surface of the drop may strike the back surface at a large enough angle of incidence to be reflected twice before getting out of the drop. The light rays cross over in this case and are deviated through larger overall angles than any of the colors in the primary bow. For this reason, the secondary bow is seen outside the arc of the primary bow. Violet light is bent through a larger angle than red light, so violet light lies at the top of the secondary rainbow.

The sun must be reasonably low in the sky for either the primary or secondary rainbow to be observed. During the summer, a late afternoon shower usually provides the best opportunity for viewing a rainbow. Rainbows can be seen at almost any time during the day from a high vantage point such as an airplane, however, and sometimes make a complete circle rather than just an arc. If you can understand why this is so, you have mastered the explanations provided here.

According to the law of refraction, the light rays are bent toward the surface normal at the first surface (going from air to glass) and away from the surface normal at the second surface (going from glass to air). If both surfaces are convex, as shown, each of these refractions bends the ray toward the axis (a line passing through the center of the lens and perpendicular to the lens). Such a lens causes light rays to converge. A *converging* lens is called a **positive lens**.

The easiest way to see that the light will bend as pictured in figure 17.15 is to imagine that each section of the lens behaves like a prism. The prism angle (the angle between the two sides) becomes larger toward the top of the lens, so that light coming through the lens near the top is bent more than light passing through near the middle. Because the prism effect gets stronger farther from the axis, light rays coming in parallel to the axis are bent by different amounts as they pass through the lens. This causes rays parallel to the axis to all pass approximately through a single point  $F$  on the opposite side of the lens, which we call the **focal point**.



**Figure 17.15** Parallel light rays passing through a simple convex lens are bent toward the axis, so that they all pass approximately through the focal point  $F$ . A lens has two focal points, one on each side.

The distance from the center of a thin lens to the focal point is called the **focal length**  $f$ . Focal length is a property of the lens that depends on how strongly the surfaces are curved and on the index of refraction of the lens material.



There is also a focal point a distance  $f$  on the other side of the lens associated with parallel light rays coming from the opposite direction. Because the paths of rays are reversible, rays that diverge from either focal point and pass through the lens will emerge parallel to the axis.

How can we use **ray-tracing with lenses** to show how images are formed by such a lens? The process is illustrated in figure 17.16 for an object lying beyond the focal point of the lens. Three rays (labeled on the diagram) are traced, taking advantage of the properties of the focal points:

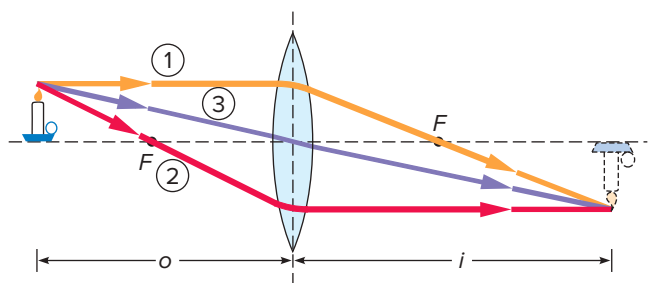
1. A ray coming from the top of the object traveling parallel to the axis is bent, so that it passes through the focal point on the far side of the lens.
2. A ray coming through the focal point on the near side emerges parallel to the axis.
3. A ray coming in through the center of the lens is undeviated and passes through the lens without being bent.

The sides of the lens near the center are parallel (like a window pane), which is why ray 3 is not bent. When tracing rays, the bending is usually shown taking place at a vertical line through the center of the lens.

The image lies on the opposite side of the lens from the object in figure 17.16 and is a *real image*, because the light rays pass through the image point. Light rays diverging from the object are converged by the lens to this image point. If you placed a screen at that point, you would see the upside-down (*inverted*) image on the screen. When a slide projector is used, the slides must be inserted upside down to produce upright images on the screen.

### How is the image distance related to the object distance?

Can we predict where an image will be found for a given location of an object? One way to do so is to carefully trace the rays, as we have already illustrated. Using triangle relationships and the law of refraction, we can also develop a



**Figure 17.16** Three rays can be traced from the top of an object through a positive lens to locate the image. If the object is beyond the focal point, an inverted real image is formed on the opposite side of the lens.

quantitative relationship between the object distance  $o$ , the image distance  $i$ , and the focal length  $f$  of a lens. (These distances are all measured from the center of the lens.) The relationship involves the reciprocals of these distances—the reciprocal of the object distance plus the reciprocal of the image distance is equal to the reciprocal of the focal length. Stated in symbols, this is

$$\frac{1}{o} + \frac{1}{i} = \frac{1}{f}$$

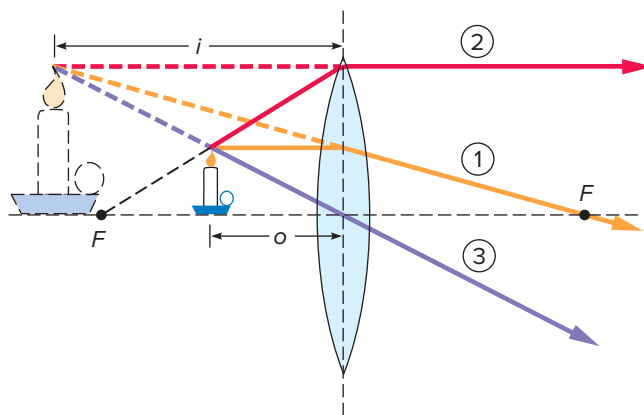
In the case in figure 17.16, these distances are all positive quantities. In the most frequently used sign convention, object and image distances for *real* objects or images are positive, but the image distance for a *virtual* image is negative. The focal length is positive for a *converging* (positive) lens, one that bends the rays toward the axis, and is negative for a *diverging* (negative) lens, one that bends the rays away from the axis (discussed more in later sections).

The geometry of figure 17.16 can also be used to find a relationship between the magnification of the image  $m$  and the object and image distances. **Magnification** is defined as the ratio of the image height  $h_i$  to the object height  $h_o$ , or

$$m = \frac{h_i}{h_o} = -\frac{i}{o}$$

The sign in this equation indicates whether the image is upright or inverted. A negative magnification represents an inverted image, as is the case when the image and object distances are both positive (fig. 17.16). Depending on the object and image distances, the image can be increased in size, reduced in size, or even unchanged in size, as in example box 17.2.

If the object lies “inside” (closer to the lens than) the focal point of a positive lens, we can get a virtual image with a positive magnification, as in figure 17.17. In this case, the image distance is a negative quantity, because it is associated with a virtual image. Light rays appear to diverge from



**Figure 17.17** A magnified virtual image is formed when the object lies inside the focal point of a positive lens. The emerging light rays appear to diverge from a point behind the object.

## Example Box 17.2

### Sample Exercise: A Real Image

An object 2 cm in height lies 10 cm to the left of a positive lens with a focal length of 5 cm.

- Where is the image located?
- What is its magnification?

$$\begin{aligned} \text{a. } f &= +5 \text{ cm} \\ o &= +10 \text{ cm} \\ i &= ? \\ \frac{1}{o} + \frac{1}{i} &= \frac{1}{f} \\ \frac{1}{i} &= \frac{1}{f} - \frac{1}{o} \\ &= \frac{1}{5 \text{ cm}} - \frac{1}{10 \text{ cm}} \\ &= \frac{2}{10 \text{ cm}} - \frac{1}{10 \text{ cm}} \\ &= \frac{2-1}{10 \text{ cm}} = \frac{1}{10 \text{ cm}} \\ i &= \mathbf{10 \text{ cm}} \end{aligned}$$

The image lies 10 cm to the right of the lens, on the opposite side of the object (fig. 17.16).

$$\begin{aligned} \text{b. } m &= ? \\ m &= -\frac{i}{o} \\ &= -\frac{10 \text{ cm}}{10 \text{ cm}} \\ &= \mathbf{-1} \end{aligned}$$

The image is the same size as the object but it is inverted, because the magnification has a negative sign.

## Example Box 17.3

### Sample Exercise: A Virtual Magnified Image

An object 2 cm in height lies 10 cm to the left of a positive lens with a focal length of 20 cm.

- Where is the image located?
- What is its magnification?

$$\begin{aligned} \text{a. } f &= +20 \text{ cm} \\ o &= +10 \text{ cm} \\ i &= ? \\ \frac{1}{o} + \frac{1}{i} &= \frac{1}{f} \\ \frac{1}{i} &= \frac{1}{f} - \frac{1}{o} \\ &= \frac{1}{20 \text{ cm}} - \frac{1}{10 \text{ cm}} \\ &= \frac{1}{20 \text{ cm}} - \frac{2}{20 \text{ cm}} \\ &= -\frac{1}{20 \text{ cm}} \\ i &= \mathbf{-20 \text{ cm}} \end{aligned}$$

The image lies 20 cm to the left of the lens, on the same side as the object (fig. 17.17).

$$\begin{aligned} \text{b. } m &= ? \\ m &= -\frac{i}{o} \\ &= -\frac{-20 \text{ cm}}{10 \text{ cm}} \\ &= \mathbf{+2} \end{aligned}$$

The image is magnified to twice the height of the object, as shown in figure 17.17. It is upright because the magnification is positive.

the image point but do not actually pass through this point. A virtual image lies on the side of the lens from which the light is coming, the left side in this case. This situation is dealt with in example box 17.3.

When we view the image of an object placed inside the focal point of a positive lens, we are using the lens as a magnifying glass. The image is magnified, but it also lies behind the object, farther from our eyes. This greater distance makes it easier for us to focus on the image than on the object itself. This is an advantage, particularly for older people who have lost the ability to accommodate their focus to view objects that are close to their eyes.

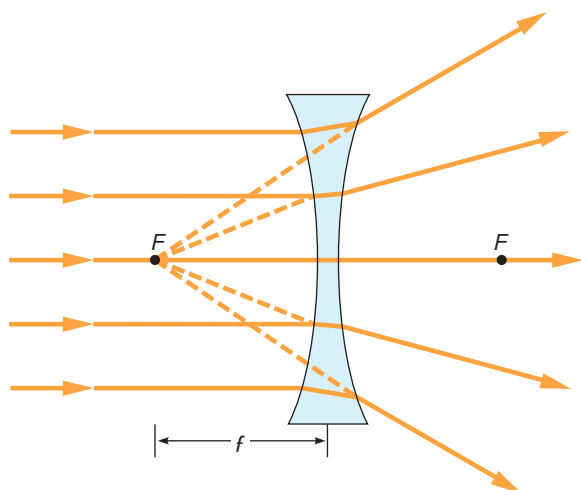
### Tracing rays through negative lenses

As we have seen, a simple convex lens is a positive, *converging* lens—it bends light rays toward the axis. What happens if we change the direction of the curvature of the lens surfaces so that they are concave rather than convex? If we imagine that each section of the lens behaves like a prism (as

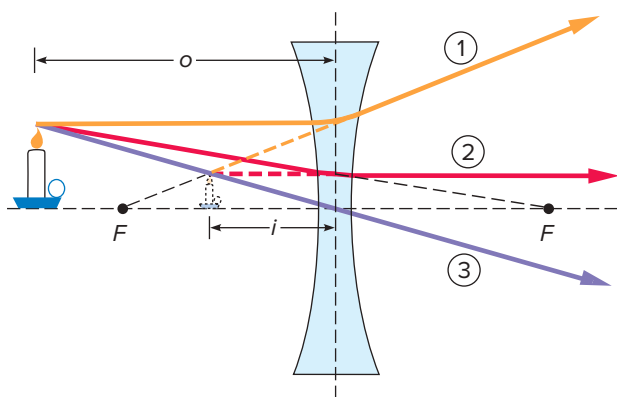
discussed at the end of section 17.2), these prism sections are upside down compared to the convex lens. As you can see in figure 17.18, these prism sections bend light rays away from the axis rather than toward it. The lens is therefore a *diverging*, or **negative**, lens.

Light rays coming in parallel to the axis are bent away from the axis by the negative lens so that they all appear to be diverging from a common point  $F$ , the focal point (fig. 17.18). This point is one of two focal points of the negative lens. The other lies on the opposite side at the same distance from the center of the lens as the first one. Light coming in toward the focal point on the far side of the lens is bent so that it comes out parallel to the axis. As mentioned earlier, the focal length  $f$  of a negative lens is defined as a negative quantity.

We can trace the same three rays we traced for the positive lens to locate an image for the negative lens, as in figure 17.19. The ray coming from the top of the object parallel to the axis (ray 1) is bent away from the axis in this case, so that it appears to come from the focal point on the



**Figure 17.18** Light rays traveling parallel to the axis are bent away from the axis by a negative lens so that they appear to diverge from a common focal point  $F$ .



**Figure 17.19** Three rays are traced from the top of an object to locate the image formed by a negative lens. The virtual, upright image lies on the same side of the lens as the object and is reduced in size.

near side of the lens. A ray coming in toward the focal point on the far side (ray 2) is bent to come out parallel to the axis. Ray 3 passes through the center of the lens undeviated, as before.

The resulting image lies on the same side of the lens as the object and is upright and reduced in size (fig. 17.19). This can be verified by using the object–image distance formula, treating the focal length as a negative quantity. The image is virtual because the rays appear to come from the image point but do not (except for the undeviated ray) actually pass through that point. This is true regardless of the object distance—a negative lens used by itself always forms a virtual image smaller than the object.

If you hold a negative lens near a printed page and view the page through the lens, the letters will appear smaller than their actual size. Distinguishing a negative lens from a positive lens is easy: One makes the print smaller, while the other (the positive lens) magnifies the print when

held close to the page. If you move the positive lens away from the page, the image disappears when you reach a distance equal to the focal length, then reappears upside down. Eyeglasses can be made with either negative or positive lenses, depending on the correction needed (see section 17.5). If you have a pair of eyeglasses handy, you can do the simple test just described to determine if the lenses are positive or negative.

A positive lens converges light toward the axis. If the incoming rays are parallel to the axis, they converge approximately to a single point, the focal point. The properties of the focal points can be used to trace rays to locate and characterize the images formed. The distance of the focal points from a thin lens is called the focal length, which can be used to find the image position for any given object position. A negative lens diverges light rays and always forms a reduced-in-size virtual image of a real object. The object–image distance formula and the associated ray-tracing techniques can be used to find and describe the images formed by both positive and negative lenses.

## 17.4 Focusing Light with Curved Mirrors

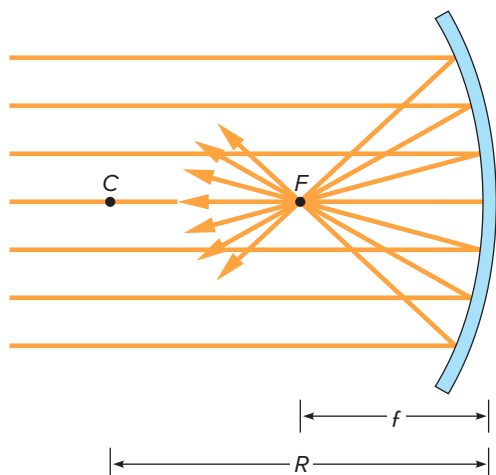
Most of us have had the experience of using a shaving or makeup mirror that magnifies features on our face. This experience can be even more disconcerting early in the morning than that provided by an ordinary mirror. What is going on here? How is the magnification accomplished?

Magnifying mirrors involve curved surfaces rather than plane surfaces. The curvature is usually spherical—the surface of the mirror is a portion of a sphere. A spherical reflecting surface has the ability to focus light rays in a manner similar to that of a lens. Simple ray-tracing techniques can provide an understanding of the resulting images.

### Ray-tracing with a concave mirror

Mirrors that produce magnification are **concave mirrors**, which means that light is being reflected from the inside of a spherical surface. Their focusing properties can be understood by following rays that approach the mirror parallel to the axis, as shown in figure 17.20. The center of curvature of the spherical surface lies on the axis, as shown, and the law of reflection dictates where each ray will go.

Each ray traced in figure 17.20 obeys the law of reflection—the angle of reflection equals the angle of incidence. The surface normal for each ray is found by drawing a line from the center of curvature of the sphere to the reflecting surface. A radius of a sphere is always perpendicular to its surface.



**Figure 17.20** Light rays approaching a spherical concave mirror traveling parallel to the axis are reflected so that they all pass approximately through a common focal point  $F$ . The focal length  $f$  is half the radius of curvature  $R$ .  $C$  is the center of curvature of the mirror.

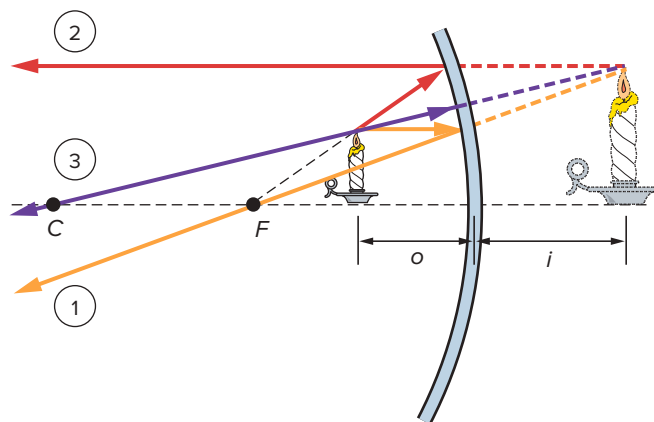
As you can see from the diagram, each ray is reflected so that it crosses the axis at approximately the same point as all the other rays. This point of intersection is the focal point, labeled with the letter  $F$ . Like the focal point of a lens, it is the point where rays coming in parallel to the axis are focused. Because any of these could be reversed in direction and still obey the law of reflection, rays that pass through the focal point on their way to the mirror will emerge parallel to the axis of the mirror.

We can also see from the diagram in figure 17.20 that the distance of the focal point  $F$  from the mirror is approximately half the distance of the center of curvature  $C$  from the mirror. These two points,  $F$  and  $C$ , can be used in tracing rays to locate and describe images formed by the mirror. When you use such a mirror to examine your face, you generally place your face “inside” the focal point (closer to the mirror). This produces the magnified image you normally observe.

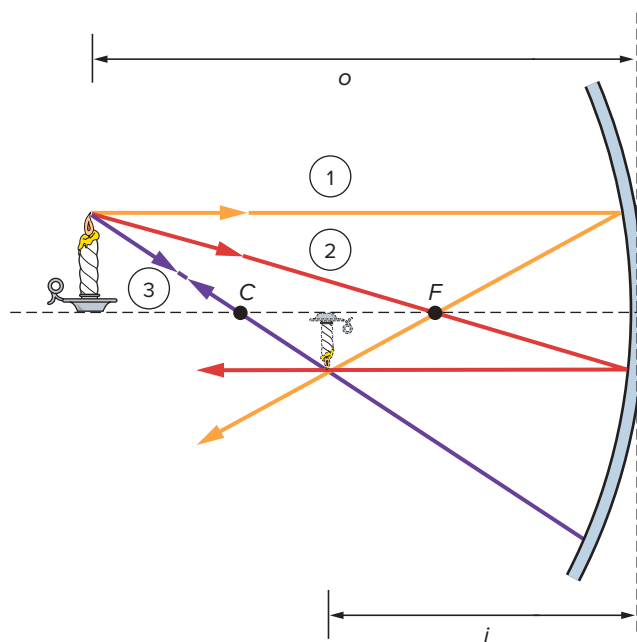
Figure 17.21 shows how **ray-tracing with mirrors** can be used to find the image of an object placed inside the focal point of the mirror. There are three rays we can easily trace, but any two of these rays would be sufficient to locate the image. The three rays are the following:

1. A ray coming from the top of the object parallel to the axis and reflected through the focal point.
2. A ray coming in through the focal point and reflected parallel to the axis.
3. A ray coming in along a line passing through the center of curvature and reflected back along itself.

The third ray comes in and out along the same line because it strikes the mirror perpendicular to its surface. The angles of incidence and reflection are both zero in this case.



**Figure 17.21** Three rays are traced from the top of the candle placed in front of the mirror. Extending the reflected rays backward locates the top of the image behind the mirror.



**Figure 17.22** Light rays coming from an object located beyond the focal point of a concave mirror converge to intersect in front of the mirror, forming an inverted real image.

When these three rays are extended backward, we see that they all appear to come from a point behind the mirror. This point defines the position of the top of the image. The bottom of the image lies on the axis. We see the image as lying behind the mirror and, as is obvious from the diagram, magnified.

The resulting image is upright, magnified, and virtual. It is a virtual image because, just as in the case of the plane mirror, the light rays do not actually pass through the image. The rays never get behind the mirror, but the image appears to lie behind the mirror.

It is also possible to form real images with a concave mirror. This occurs when the object is located beyond the focal point of the mirror, as illustrated in figure 17.22. In this

case, when the three rays are traced, we see that they converge rather than diverge as they leave the mirror. The rays coming from the top of the object intersect at a point on the same side of the mirror as the object, then diverge again from this point. If our eyes collect these rays, we see an image that lies in front of the mirror.

Because we are used to looking at images that lie behind a mirror, it is a little harder for us to focus on one lying in front. This image can be observed, however, using a curved makeup or shaving mirror. As you move the mirror away from your face, the original magnified image becomes larger and finally disappears. It is replaced by an upside-down image that grows smaller as you continue to move away from the mirror. This image is a real image because the light rays do pass through the image and then diverge again from these points. As is also clear from the diagram, the image is inverted (upside down).

### Object and image distances

Can we predict where an image will be found for a given location of an object? One way of doing this is simply to carefully trace the rays as already illustrated. Using triangle relationships and the law of reflection, it is also possible to develop a quantitative relationship between the object and image distances. The relationship turns out to be the same as that stated earlier for a lens:

$$\frac{1}{o} + \frac{1}{i} = \frac{1}{f}$$

The object distance  $o$ , the image distance  $i$ , and the focal length  $f$  are all measured from the vertex, the point where the axis meets the mirror. As shown in figure 17.20, the focal length is half the radius of curvature.

In the case shown in figure 17.22, these distances are all positive quantities. In general, distances are positive if they lie on the same side of the mirror as the light rays themselves. If they lie behind the mirror, the distances are negative. The exercise in example box 17.4 demonstrates the use of the relationship between object and image distances.

The triangles in figures 17.21 and 17.22 can also be used to find a relationship between the image height and object height—or in other words, the magnification,  $m$ . This relationship is also the same as that obtained earlier for a lens:

$$m = -\frac{i}{o}$$

In example box 17.4, where the image distance is  $-10$  cm and the object distance  $+5$  cm, the magnification is  $+2.0$ . In other words, the image height is twice that of the object. The fact that this magnification is positive indicates that the image in this case is upright.

### Convex mirrors

Up to this point, we have been considering concave mirrors, which curve inward toward the viewer. What happens if the

## Example Box 17.4

### Sample Exercise: Finding an Image for a Concave Mirror

An object lies 5 cm to the left of a concave mirror with a focal length of  $+10$  cm. Where is the image? Is it real or virtual?

$$\begin{aligned} o &= 5 \text{ cm} \\ f &= 10 \text{ cm} \\ i &= ? \end{aligned}$$

$$\frac{1}{o} + \frac{1}{i} = \frac{1}{f}$$

$$\frac{1}{i} = \frac{1}{f} - \frac{1}{o}$$

$$\frac{1}{i} = \frac{1}{10 \text{ cm}} - \frac{1}{5 \text{ cm}}$$

$$\frac{1}{i} = \frac{1}{10 \text{ cm}} - \frac{2}{10 \text{ cm}}$$

$$\frac{1}{i} = -\frac{1}{10 \text{ cm}}$$

$$i = -10 \text{ cm}$$

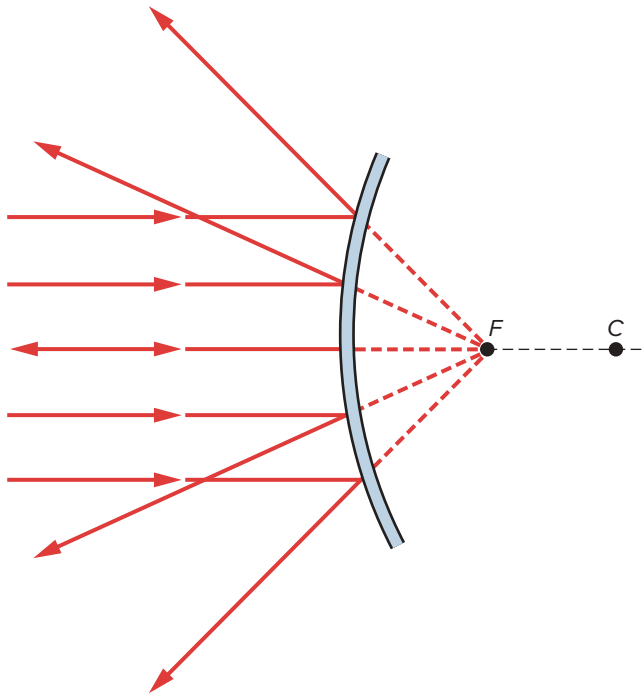
Because the image distance is negative, the image lies 10 cm behind the mirror and is virtual. The situation is much like that pictured in figure 17.21.

mirror curvature is in the opposite direction? **Convex mirrors**, for which light is reflected from the outside of the spherical surface, are used as wide-angle mirrors in store aisles or as the side-view mirror on the passenger side of a car. These mirrors produce a reduced-in-size image but a large field of view. It is this wide-angle view that makes them useful.

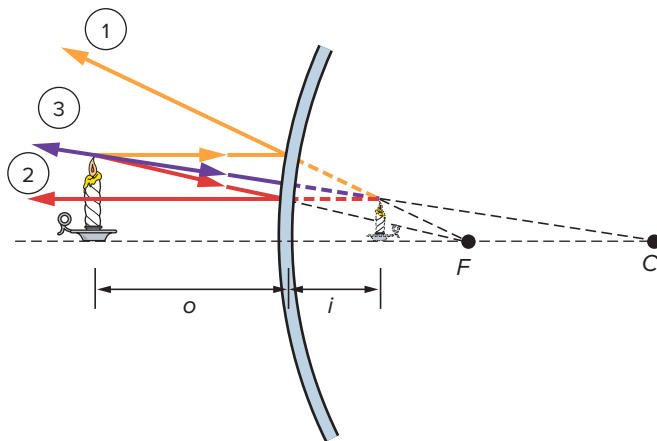
Figure 17.23 pictures rays approaching a convex mirror traveling parallel to the axis of the mirror. The center of curvature  $C$  lies behind the mirror in this case. Lines drawn from the center of curvature are perpendicular to the surface of the mirror, as before. The law of reflection dictates that the parallel rays will be reflected away from the axis, as shown. When the reflected rays are extended backward, they all appear to have come from the same point  $F$ , the focal point.

A convex mirror is therefore a diverging, or *negative*, mirror. Parallel light rays diverge as they leave the mirror, rather than converge, as they do with a concave mirror. We can use the same ray-tracing techniques, however, to locate an image. Figure 17.24 illustrates this process. The ray coming from the top of the object traveling parallel to the axis (1) is reflected as though it came from the focal point. A ray coming in toward the focal point (2) is reflected parallel to the axis, and the ray coming in toward the center of curvature (3) is reflected back along itself because it is perpendicular to the surface.

When extended backward, these three rays all appear to come from a point behind the mirror, thus locating the top of the image. The image is virtual because it lies behind the



**Figure 17.23** Light rays traveling parallel to the axis of a convex mirror are reflected so that they appear to come from a focal point,  $F$ , located behind the mirror.



**Figure 17.24** Three rays are traced to locate the virtual image of an object placed in front of a convex mirror. The reflected rays diverge as though coming from the image point behind the mirror.

mirror, and it is obviously upright and reduced in size. Check it out the next time you are in a store that has one of these mirrors mounted above an aisle. The images are small but cover a broad area.

The object–image distance formula for concave mirrors and lenses can also be used to locate images for a convex mirror. The one difference is that the focal length of a convex mirror must be treated as a negative quantity, like that for a negative lens. The image formed by a convex mirror always

lies behind the mirror, and therefore the image distance will always be negative for any object distance you choose.

The side mirror on the passenger side of a car is usually a convex mirror. It produces a wide-angle view of the traffic lane to the right. Because it is a negative mirror, the image is reduced in size and lies just behind the mirror, as in figure 17.24. However, there is usually a warning written on the mirror, saying “OBJECTS IN MIRROR ARE CLOSER THAN THEY APPEAR.” How can this be if the image being viewed is very close to the mirror itself?

The answer lies in the fact that our brains use many different cues to determine distance. In this case, because the size of the image viewed in the mirror is small, our brains interpret this as meaning that the vehicles must be farther away than they actually are. We know the actual size of that truck or car, and our brains use this size information to determine distance. If you viewed some object of unknown size, your binocular depth perception could place the image of this object at the actual image location behind the mirror.

Mirrors with curved surfaces can be used to focus light rays and form images. We can locate and describe these images by tracing rays associated with the focal point of the mirror and its center of curvature. The same formula used for lenses can be used to relate object and image distances for mirrors. A concave mirror produces a magnified virtual image when the object is inside the focal point, and real images when the object is beyond the focal point. A convex mirror produces a reduced-in-size image for any object position but provides a wide angle of view.

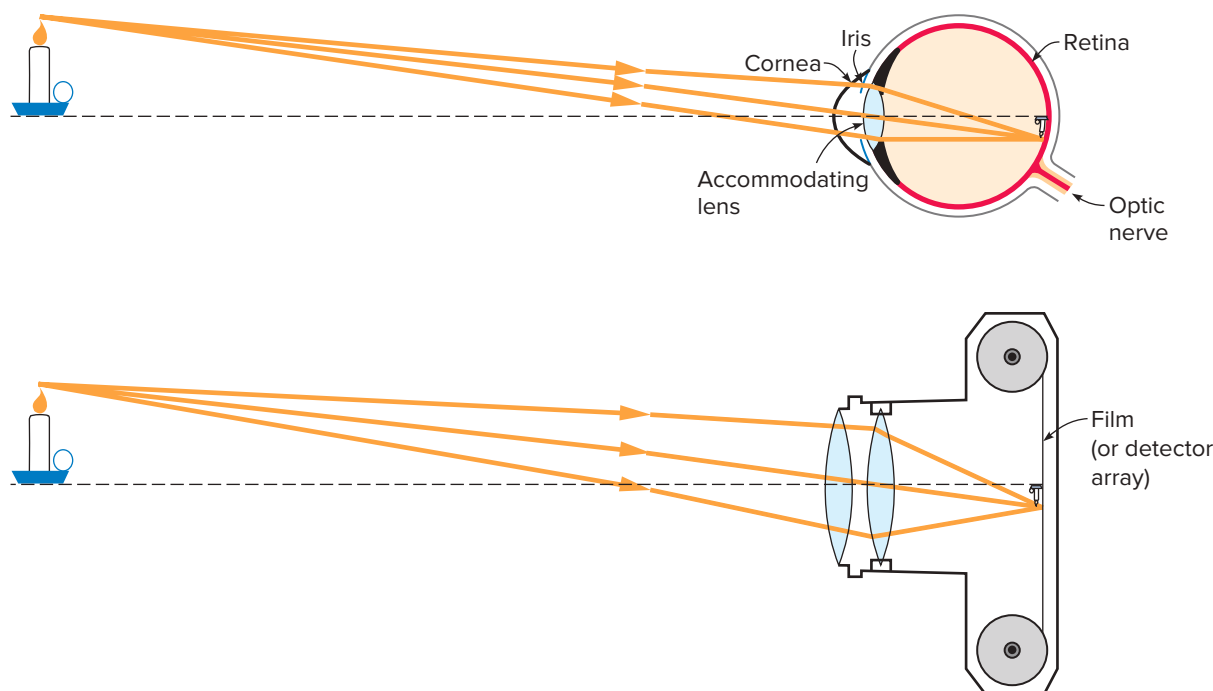
## 17.5 Eyeglasses, Microscopes, and Telescopes

Lensmaking was an art that developed during the Renaissance. Before then, it was not possible to correct visual problems such as nearsightedness or farsightedness or to magnify objects with a magnifying glass. Once lenses became common, though, it did not take long for people to discover that they could be combined to make optical instruments, like microscopes and telescopes. Both were invented in Holland in the early 1600s.

Correction of visual problems is still the most familiar use of lenses. Most of us will wear eyeglasses at some time in our lives, and many of us have worn them since adolescence or even earlier. What goes wrong with our vision that requires corrective lenses? To answer that question, we need to explore the optics of the eye itself.

### How do our eyes work?

Our eyes contain positive lenses that focus light rays on the back surface of the eyeball when working properly. As shown



**Figure 17.25** Light rays entering the eye from a distant object are focused on the back surface of the eye (the retina) by the cornea and the accommodating lens, much as light rays are focused on the film (or detector array) by a camera lens.

in figure 17.25, the eye actually contains two positive lenses—the *cornea*, which is the curved membrane forming the front surface of the eye, and the *accommodating lens* attached to muscles inside the eye. Most of the bending of light occurs at the cornea. The accommodating lens is more for fine-tuning.

There is a good analogy between the eye and a camera. A camera uses a compound positive lens system to focus light rays coming from objects being photographed onto the film at the back of the camera. The lens system in a camera can be moved back and forth to focus on objects at different distances from the camera. In the eye, the distance between the lens system and the back surface of the eye is fixed, so that we need a variable focal-length lens, the accommodating lens, to focus on objects at different distances.

The positive lenses form an inverted real image on the *retina*, the layer of receptor cells on the back inside surface of the eye. The retina plays the role of the film in a camera and is the sensor that detects the image. In a digital camera, the film is replaced with an array of tiny light detectors, making the analogy to the retina even better. The light reaching the cells in the retina initiates nerve impulses that are carried to our brain. Similarly, the detector array in a digital camera sends electrical signals to the memory card, creating an image. The brain processes the nerve impulses received from both eyes and interprets the image according to its experience. Most of the time this interpretation is straightforward, and what we see is what we get, but at times, the brain's interpretation can produce misleading impressions.

Even though the image on the retina is upside down, our brains interpret the scene as right side up. Interestingly, if people are fitted with inverting lenses that turn the image on

the retina right side up, they initially see things as being upside down. After some time, the brain makes an adjustment, and they begin to see things right side up again. Everything is fine until they take the inverting lenses off. Then, everything appears to be upside down again until the brain readjusts! A great deal of processing takes place between the signal received by your eyes and what you actually perceive.

### What problems are corrected with eyeglasses?

The most common visual problem of people who do a lot of reading is nearsightedness, or **myopia**. The eyes of a nearsighted person bend the light rays from a distant object too strongly, causing them to focus in front of the retina, as in figure 17.26a. By the time the rays reach the retina, they are diverging again and no longer form a sharp focus. Things appear fuzzy, although we sometimes fail to notice, because we grow accustomed to this indistinct view. A myopic person can see near objects distinctly, because the incident light rays are diverging more strongly from a near object than from a distant object.

Negative eyeglass lenses correct for the tendency of the eye itself to converge the light rays too strongly (fig. 17.26b). Because a negative lens diverges light rays, it compensates for the excessive convergence by the lenses in the eye and forms distinct images of distant objects on the retina. For a nearsighted person who has not worn glasses before, the difference can be striking.

A farsighted person has the opposite problem. The eye does not converge light rays strongly enough, and images of near objects are formed behind the retina. Positive lenses correct this problem. Laser refractive surgery (see everyday phenomenon

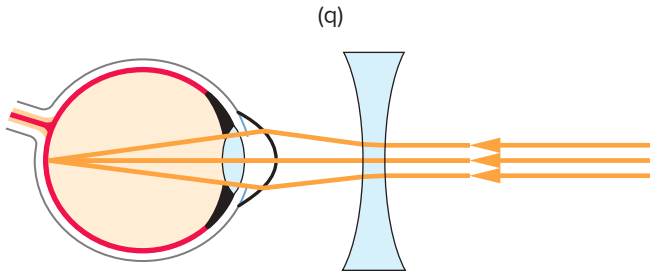
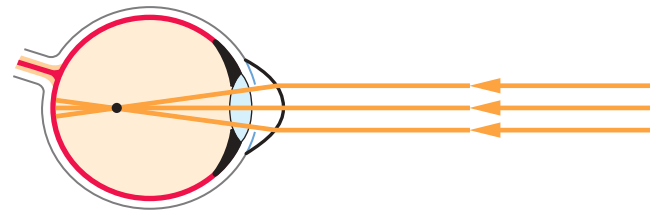
If you have ever used a microscope, you know that the object being viewed is placed near the first lens, called the *objective lens*. The objective lens forms a real, inverted image of the object, provided that the object lies beyond the focal point of the objective lens. If the object lies just beyond this focal point, the real image has a large image distance and the image is magnified. This can be verified by tracing rays or by using the object-image distance formula.

Because light rays actually pass through a real image and diverge again from that point, this real image becomes the object for the second lens in the microscope. The eyepiece lens, or *ocular*, is used like a magnifying glass to observe the real image formed by the objective lens. This real image is focused just inside the focal point of the eyepiece, which then produces the magnified virtual image we see. The virtual image is also located farther from the eye, so it can be focused on more readily (fig. 17.27).

Both lenses in a microscope cooperate to produce the desired magnification. The objective lens forms a magnified real image, and this image is magnified again by the eyepiece. The overall magnification of the microscope is found by multiplying these two magnifications together, sometimes achieving magnifications of several hundred times the original object size.

Because eyepiece powers have a limited range, the magnification power of a microscope is determined primarily by the power of the objective lens. A high-power objective lens has a very short focal length, and the object must be placed very close to the objective lens. Microscopes often have three or four objective lenses of different powers mounted on a turret (fig. 17.28).

The invention of the microscope opened up a whole new world for biologists and other scientists. Microorganisms too small to be seen with the naked eye or with a simple magnifying glass became visible when viewed through a microscope.

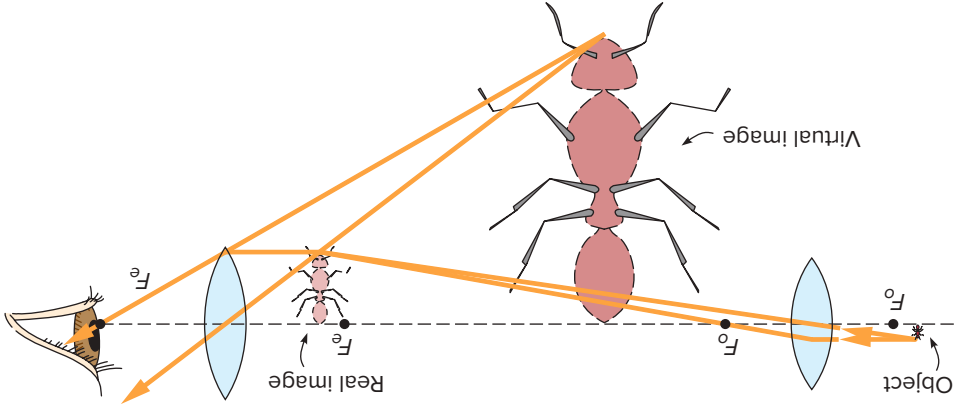


**Figure 17.26** For a nearsighted person, parallel light rays from a distant object are focused in front of the retina. A negative lens placed in front of the eye can correct this problem.

box 17.2) can correct both nearsightedness and farsightedness by reshaping the cornea, eliminating the need for eyeglasses. As we age, the accommodating lenses lose their flexibility. We gradually lose the ability to change the converging power of our eyes and cannot focus on near objects, because light rays diverge more strongly from near objects than from distant objects. At this point, we need bifocals, in which the top half of the lens has one focal length and the bottom half another. We look through the bottom half to do close work and through the top half to view distant objects.

### How does a microscope work?

How are lenses combined to form a microscope? A microscope consists of two positive lenses spaced as shown in figure 17.27. They are usually held together by



**Figure 17.27** A microscope consists of two positive lenses separated by a connecting tube (not shown). The real image formed by the first lens is viewed through the second lens. Both lenses produce magnification.



## Everyday Phenomenon

## Box 17.2

## Laser Refractive Surgery

**The Situation.** Megan Evans has been nearsighted since her early teens. She has worn contact lenses for several years, after first using spectacle lenses. Now in her twenties, she has heard friends talk about a procedure called laser refractive surgery that can allow people to see well without corrective lenses. She is intrigued and wants to know more about it.

How can bombarding her eye with a laser beam improve her vision? She knows that lasers can be dangerous in other situations. Is this procedure safe? How does it work, and can it help her situation?

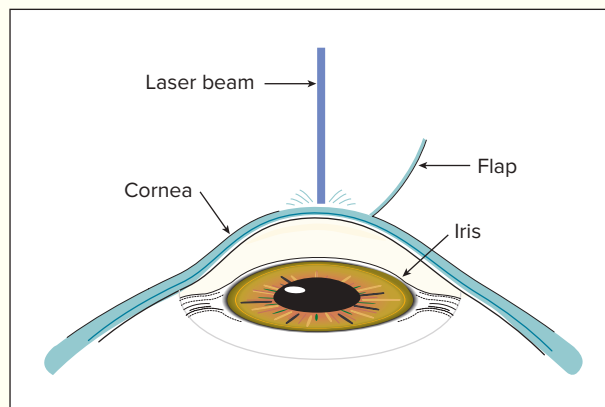
**The Analysis.** In our culture, myopia, or nearsightedness, is the most common visual problem. It may develop from doing a lot of near work, such as reading during childhood, although there are also hereditary factors. As described in figure 17.26, the lens system of the myopic eye is too strong, which causes light from distant objects to focus in front of the retina rather than on the retina.

Most of the optical power of the eye is produced by the front surface of the cornea. Optical power is measured in diopters, which is the reciprocal of the focal length measured in meters ( $P = 1/f$ ) when the lens is surrounded by air. The shorter the focal length, the stronger the optical power, because a short focal length implies that the light rays are being strongly bent by the lens. The overall power of the lens system of the eye is about 60 diopters, but the front surface of the cornea produces 40 to 50 diopters by itself.

The optical power of the cornea (or of any lens) is determined by two things—how strongly the surface is curved and the difference in index of refraction on either side of the surface. For a nearsighted person, the surface of the cornea is too strongly curved for the length of the eyeball. It is not unusual for a person like Megan to have an optical power of the cornea that is too strong by 4 to 5 diopters. She then requires a corrective lens of  $-4$  to  $-5$  diopters to allow her to see distant objects clearly.

The purpose of laser refractive surgery is to reshape the cornea by vaporizing different portions of the cornea by different amounts. The most commonly used procedure is called LASIK, which is an acronym for *laser assisted in situ keratomileusis*. In this procedure, the surgeon cuts a circular flap of the outer layer of the cornea with a surgical scalpel and pulls this flap to the side, as shown in the drawing. She then uses a pulsed *excimer laser* to vaporize small amounts of corneal tissue to produce a predetermined new shape for the central portion of the cornea. When finished, the flap of the outer layer is replaced.

The excimer laser used has a wavelength of 192 nm, which lies in the ultraviolet portion of the spectrum. This wavelength is



In the LASIK procedure, a circular flap of the outer layer of the cornea is pulled aside. Controlled pulses from the laser reshape the central region of the cornea.

strongly absorbed by corneal tissue, so it vaporizes, or *ablates*, this tissue without heating the surrounding tissue. The laser operates in a pulsed mode, with each pulse delivering a definite amount of energy. The surgeon can then control how much tissue is ablated by the number of pulses that are delivered to each section of the cornea. This is all controlled by a computer program to achieve the desired new shape.

The LASIK procedure is done on an outpatient basis, and the cornea heals in just a few days. When successful, the reshaped cornea generally allows a person to discard any glasses or contact lenses. Sometimes, a weak correction is still needed because the cornea does not heal to quite the desired power. Older people who have lost the ability to accommodate will generally still need reading glasses unless one eye is shaped to have a stronger power than the other. The LASIK procedure is most commonly used to cure myopia, where the goal is to flatten the shape of the cornea. It can also be used, though, for farsightedness (hyperopia) or astigmatism. In the case of astigmatism, the cornea is not spherical and this can be addressed by reshaping with the laser.

Is the procedure safe? The jury is still out on possible long-term effects, but most patients experience only minor problems, if any. There is always a small risk of infection or poor healing, as with any surgical procedure. People sometimes experience problems with night vision after undergoing LASIK. This is because only the central portion of the cornea is reshaped, so there is then a circular boundary between the reshaped and untreated portions of the cornea. At night when light levels are low, the pupil of the eye opens more widely and some light may get through this boundary region, producing blurring of the image.

Seemingly clean pond water was revealed to be teeming with life. The structure of a fly's wing and various kinds of human tissue suddenly became apparent. The microscope is a striking example of how developments in one area of science have a dramatic impact on other areas.

### How does a telescope work?

The development of the microscope opened up the world of the very small. The earlier invention of the telescope had an equally dramatic impact in opening up the world of distant objects. Astronomy was the primary beneficiary. A simple



**Figure 17.28** A laboratory microscope often has three or four objective lenses mounted on a rotatable turret. Light passes through the object slide from a source below the slide. *James Ballard/McGraw-Hill Education*

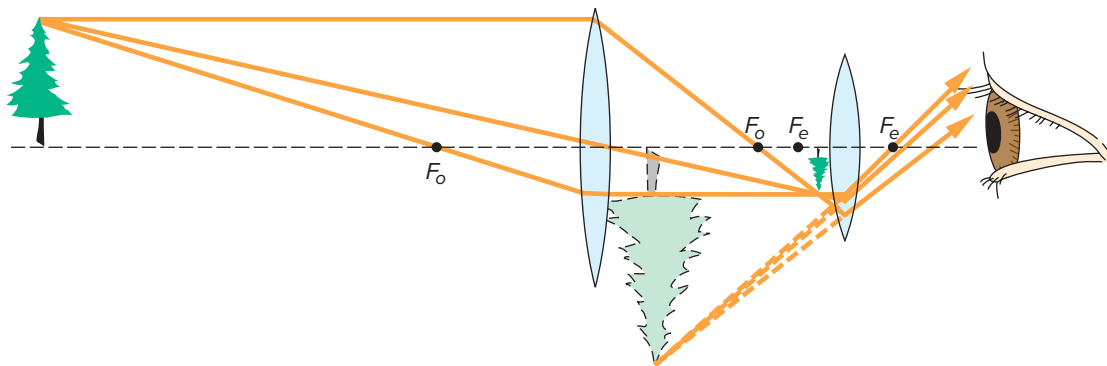
astronomical **telescope**, like a microscope, can be constructed from two positive lenses. How does a telescope differ from a microscope in its design and function?

Distant objects, such as stars, are very large but so far away that they appear to be tiny. One obvious difference between a microscope and a telescope is that objects viewed with a telescope are much farther from the objective lens. As shown in figure 17.29, the objective lens of a telescope, like that of a microscope, forms a real image of the object, which is then viewed through the eyepiece. Unlike the real image formed by a microscope, however, that formed by a telescope is reduced in size rather than magnified.

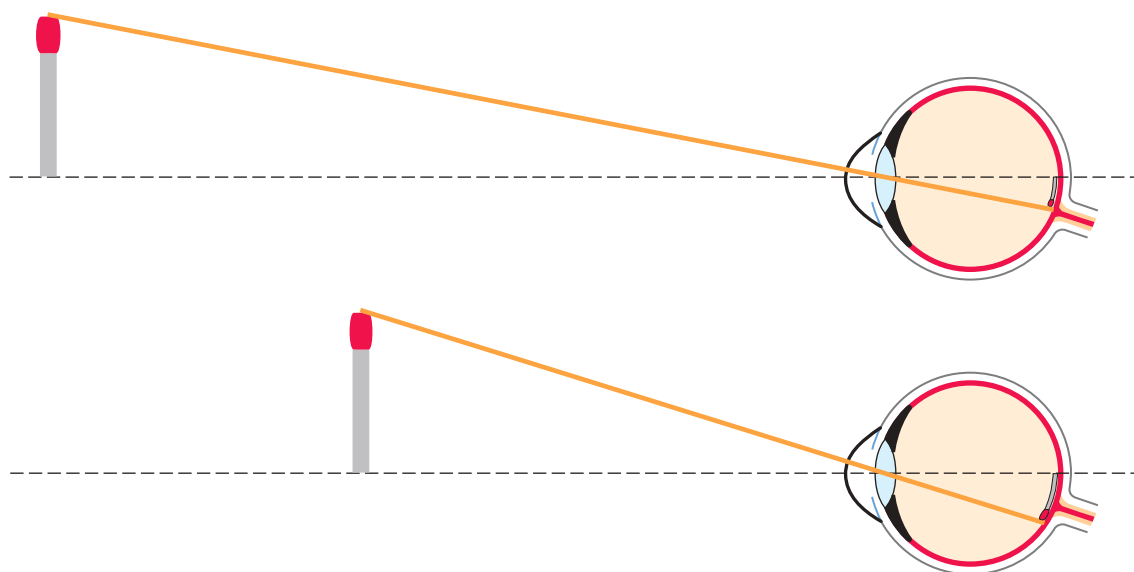
If the real image formed by the objective lens is smaller than the object, how can there be an advantage to using a telescope? The answer is that this image is much closer to the eye than the original object. Even though this image is smaller than the object itself, it forms a larger image on the retina of the eye when viewed through the eyepiece. Figure 17.30 shows two objects of equal height at different distances from the eye. By assuming that the images of both objects are focused on the retina and tracing just the central undeviated ray from the top of each object, we see that the nearer object forms a larger image on the retina.

When you want to see fine detail on an object, you bring the object closer to your eye to take advantage of the larger image formed on the retina. Because the size of the image on the retina is proportional to the angle that the object forms at the eye, we say that we have achieved an *angular magnification* by bringing the object nearer. We are limited in how close we can bring the object by the focusing power of the eye. The eyepiece of either a telescope or a microscope solves this problem by forming a virtual image farther from the eye but at the same angle as the original real image.

The magnifying effect of a telescope is basically an angular magnification. Because it is closer to the eye, the image seen through the telescope forms a larger angle at the eye than the original object. This larger angle produces a larger image on the retina and allows us to see more detail on the



**Figure 17.29** The objective lens of a telescope forms a real, reduced image of the object, which is then viewed through the eyepiece. The real image is much closer to the eye than the original object. (Not drawn to scale.)



**Figure 17.30** Two objects of the same size but at different distances from the eye form different-sized images on the retina. We can see more detail on the nearer object.

object, even though the real image is much smaller than the actual object.

The overall angular magnification produced by a telescope is equal to the ratio of the focal lengths of the two lenses:

$$M = (-)\frac{f_o}{f_e}$$

where  $f_o$  is the focal length of the objective lens,  $f_e$  is the focal length of the eyepiece lens, and  $M$  is the angular magnification. A minus sign is sometimes included in this relationship to indicate that the image is inverted. From this relationship, we see that it is desirable to have a large focal length for the objective lens of a telescope to produce a large angular magnification. A microscope, on the other hand, uses an objective lens with a very short focal length. This is the fundamental difference in the design of telescopes and microscopes.

The large telescopes used in astronomy have concave mirrors instead of lenses for the objective lens. The objects astronomers study are often very dim, and the telescope must collect as much of their light as possible. This requires an objective lens or mirror with a large *aperture*, or opening, for the incoming light. Because it is easier to make and physically support large mirrors than large lenses, concave mirrors are used in the telescopes at most observatories.

### Binoculars and opera glasses

The image formed by an astronomical telescope is inverted, like the image formed by a microscope. The inverted image is not a big problem for viewing stars or planets, but it can

be confusing for viewing objects on land. The most familiar form of land, or *terrestrial*, telescope is a pair of prism binoculars, which use multiple reflections in the prisms to reinvert the image (fig. 17.31).

Opera glasses are a simpler form of terrestrial telescope. The two tubes are straight, and the image is reinverted by using negative instead of positive lenses for the eyepieces. Using negative lenses has the additional advantage of making the tubes shorter, because the negative lenses must be placed in front of where the real image would be formed. The disadvantage of opera glasses is their narrow field of view and weak magnification. They fit into a purse or pocket more readily than prism binoculars, though.



**Figure 17.31** Opera glasses and prism binoculars employ different means of reinverting the image so that it is upright.  
Bob Coyle/McGraw-Hill Education

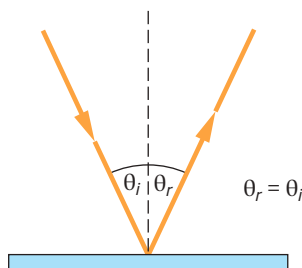
The two tubes in binoculars and opera glasses allow us to use both eyes when viewing distant objects. Using both eyes preserves some of the three-dimensional aspects of what we see. In normal vision, your two eyes form slightly different images of what you are viewing, because each eye sees objects from a slightly different angle. Your brain interprets these differences as being produced by three-dimensional features of the scene. Try closing one eye when you are viewing near objects, and then reopen that eye. Can you see the difference? A person with just one functional eye sees a flatter world at first, although the brain can make use of head movements and other cues for judging distances.

Our eyes are similar to cameras. They use positive lenses to focus an inverted image on the retina or film. If the point of focus does not lie on the retina, we need corrective lenses. Negative lenses are used to correct nearsightedness and positive lenses to correct farsightedness. A microscope uses a combination of positive lenses to produce a magnified virtual image. The overall magnification is the product of the magnifications produced by each lens. A telescope produces an angular magnification of distant objects by bringing the image we view closer to our eyes. Binoculars and opera glasses are terrestrial telescopes that reinvert the image and allow us to use both eyes.

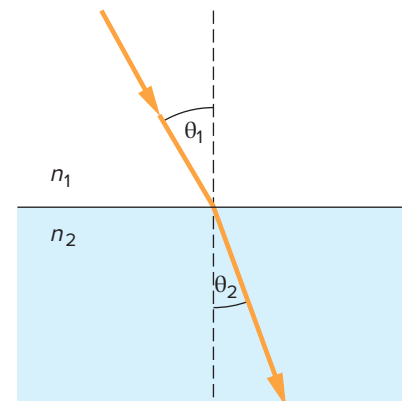
## Summary

For many purposes, the propagation of light can be studied using rays drawn perpendicular to the wavefronts. The laws of reflection and refraction are the basic principles governing these rays. Using these ideas, we can explain how images are formed by mirrors and lenses and how these elements can be combined to make optical instruments.

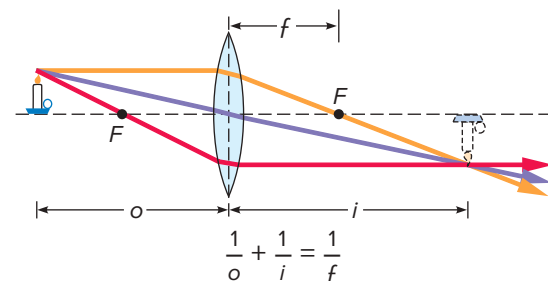
**1 Reflection and image formation.** The law of reflection states that the angle that the reflected ray makes to an axis drawn perpendicular to the surface equals the angle made by the incident ray. The image formed by a plane mirror is the same distance behind the mirror as the object is from the front of the mirror. Light rays appear to diverge from this image.



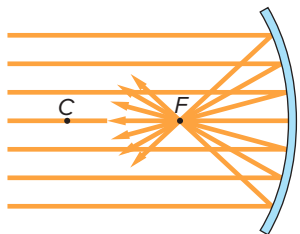
**2 Refraction of light.** A light ray passing into glass or water from air is bent toward the axis by an amount that depends on the index of refraction  $n$ . Because of this bending, the image of an underwater object seems to lie closer to the surface than it actually does. The index of refraction depends on the wavelength of the light causing *dispersion* or different amounts of bending for different colors.



**3 Lenses and image formation.** Lenses can focus light rays to form either real or virtual images. A convex, or *positive*, lens converges light rays and can be used as a magnifying glass. A concave, or *negative*, lens diverges light rays and forms reduced images. Image positions can be predicted by ray-tracing or by using the object–image equation.



**4 Focusing light with curved mirrors.** A mirror with a spherical curved surface can focus light so that incoming parallel rays pass through or appear to come from a single focal point. A concave mirror can form real images or magnified virtual images with a wide angle of view.



**5 Eyeglasses, microscopes, and telescopes.** Lenses can be used to correct vision problems and can also be combined to make optical instruments. Negative lenses are prescribed for

nearsightedness and positive lenses for farsightedness. A microscope forms a magnified real image of the object with the objective lens. This real image is then magnified again when viewed through the eyepiece. A telescope produces an angular magnification by forming an image of a distant object that is much nearer to the eye than the original object.

Connect has mastery quizzes (which generally help with conceptual understanding) and practice problems (which generally give you practice with computational exercises). Try these to give yourself additional experience with these ideas. Physics is *not* a spectator sport!

## Key Terms

Geometric optics, 355  
Physical optics, 355  
Wavefront, 355  
Surface normal, 356  
Law of reflection, 356  
Index of refraction, 358  
Law of refraction, 359

Dispersion, 361  
Positive lens, 363  
Focal point, 363  
Focal length, 363  
Ray-tracing with lenses, 364  
Magnification, 364  
Negative lens, 365

Concave mirror, 366  
Ray-tracing with mirrors, 367  
Convex mirror, 368  
Myopia, 370  
Microscope, 371  
Telescope, 373

## Conceptual Questions

\* = more open-ended questions, requiring lengthier responses, suitable for group discussion

Q = sample responses are available in appendix D

Q = sample responses are available in Connect

Q1. Does either the velocity or the speed of light change when a beam of light is reflected from a mirror? Explain.

Q2. Does light actually pass through the position of the image formed by a plane mirror? Explain.

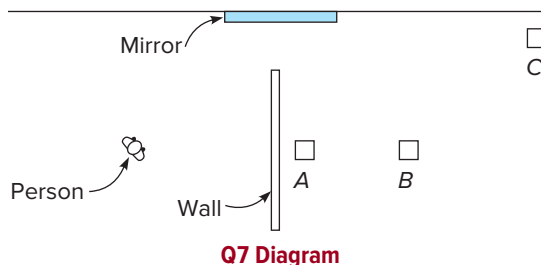
Q3. How can an image lie behind a mirror hanging on a wall when no light can reach that point? Explain.

\*Q4. When you view your image in a plane mirror, your right hand appears to be your left hand and vice versa. Explain how this reversal occurs.

Q5. If you want to view your full height in a plane mirror, must the mirror be as tall as you are? Explain using a ray diagram.

Q6. Can a plane mirror focus light rays to a point as a positive lens does? Explain.

Q7. Objects A, B, and C lie in the next room, hidden from direct view of the person shown in the diagram. A plane mirror is placed on the wall of the passageway between the two rooms, as shown. Which of the objects will the person be able to see in the mirror? Explain using a ray diagram.



Q7 Diagram

\*Q8. When two plane mirrors are joined at right angles to each other, three images of an object can be seen. The image of the object formed by each mirror can serve as the object for the other mirror. Where is the third image located? Explain using a ray diagram.

Q9. A light ray traveling in water ( $n = 1.33$ ) passes from the water into a rectangular piece of glass ( $n = 1.5$ ). Is the light ray bent toward the surface normal (the axis drawn perpendicular to the surface) of the glass or away from that axis? Explain.

Q10. Does either the speed or the velocity of light change when light passes from air into a glass block? Explain.

Q11. When we view an underwater object, is the image we see a real image or a virtual image? Explain.

- Q12.** A fish swimming in a pond looks up at an object lying a couple of feet above the surface of the water. Does this object appear to the fish to lie nearer to the surface or farther from the surface than its actual distance? Explain.
- Q13. A light ray traveling in glass for which the critical angle is  $42^\circ$  strikes a surface between the glass and air at an angle of  $45^\circ$  to the surface normal. Is this ray refracted into the air at this surface? Explain.
- Q14. Do light waves of different colors all travel at the same speed in glass? Explain.
- Q15.** Is reflection or refraction responsible for the separation of colors in a rainbow? Explain. (See everyday phenomenon box 17.1.)
- Q16. Can we see a rainbow by looking eastward if it is raining in the early morning? Explain. (See everyday phenomenon box 17.1.)
- Q17. An object is located at a distance twice the focal length from a positive lens. Trace three rays from the top of the object to locate the image. Is the image real or virtual, upright or inverted?
- Q18.** Is it possible to form a virtual image with a positive (converging) lens? Explain.
- Q19. An object is located at the left-side focal point of a negative lens. Trace three rays from the top of the object to locate the image. Is the image real or virtual, upright or inverted?
- \*Q20. Is there any position in which an object can be placed in front of a negative (diverging) lens that will result in the formation of a real image? Explain.
- Q21.** Suppose light rays approach a negative lens so that they are converging toward the focal point on the far side of the lens. Will these rays be diverging when they leave the lens? Explain.
- Q22. Do rays traveling parallel to the axis of a concave mirror pass through the center of curvature of the mirror after they are reflected? Explain.
- Q23. An object is located at the center of curvature of a concave mirror. Trace two rays from the top of the object to locate the image formed by the mirror. Is the image real or virtual, upright or inverted? Explain.
- Q24.** An object is located inside the focal point of a concave mirror. Will the image of the object be nearer or farther from the observer than the object itself? Explain.
- Q25. Is there any distance at which an object can be located in front of a convex mirror that will produce a real image? Explain.
- Q26. Why would you use a convex mirror rather than a concave or plane mirror for viewing activities in a store aisle? Explain.
- \***Q27.** When a convex mirror is used as a side-view mirror on an automobile, where is the image located? Why does printing on the mirror warn you that vehicles may be closer than they appear to be when viewed in the mirror? Explain.
- Q28. Does a nearsighted person have trouble seeing near objects? Explain.
- Q29. Would you use a positive lens or a negative lens to correct the vision of a farsighted person? Explain.
- Q30.** For a nearsighted person, is the lens of the cornea too strongly curved or not curved enough? Explain. (See everyday phenomenon box 17.2.)
- Q31. What two factors determine the optical power of the cornea? Explain. (See everyday phenomenon box 17.2.)
- Q32. Does each of the two lenses used in a microscope produce a magnification of the object being viewed? Explain.
- Q33.** Does each of the two lenses used in a telescope produce a magnification of the object being viewed? Explain.
- Q34. Is it possible to produce an angular magnification of an object by simply bringing the object closer to your eye? Explain.
- Q35. Is the objective lens of a microscope likely to have a longer focal length than that of the objective lens of a telescope? Explain.
- Q36.** What advantages might there be to using binoculars rather than an astronomical telescope for viewing distant objects on land? Explain.

## Exercises

- E1. A man with a height of 1.7 m stands 2.5 m in front of a plane mirror, viewing his image. How tall is the image, and how far from the man is the image located?
- E2. A fish lies 54 cm below the surface of a clear pond. If the index of refraction of water is assumed to be 1.33 and that of air is approximately 1, how far below the surface does the fish appear to a person looking down from above?
- E3. A rock appears to lie just 17 cm below the surface of a smooth stream when viewed from above the surface of the stream. Using the indices of refraction given in exercise 2, what is the actual distance of the rock below the surface?
- E4. An insect is embedded in a piece of amber ( $n = 1.54$ ), so that it is located 2.4 cm below a plane surface of the block. How far from this surface does this insect appear to a person looking at the block?
- E5. A positive lens has a focal length of 6 cm. An object is located 18 cm from the lens.
- How far from the lens is the image?
  - Is the image real or virtual, upright or inverted?
  - Trace three rays from the top of the object to confirm your results.

- E6. A positive lens has a focal length of 12 cm. An object is located at a distance of 4 cm from the lens.
- How far from the lens is the image?
  - Is the image real or virtual, upright or inverted?
  - Trace three rays from the top of the object to confirm your results.
- E7. A positive lens forms a real image of an object placed 6 cm to the left of the lens. The real image is found 17 cm to the right of the lens. What is the focal length of the lens?
- E8. A negative lens has a focal length of  $-15$  cm. An object is located 27 cm from the lens.
- How far from the lens is the image?
  - Is the image real or virtual, upright or inverted?
- E9. A magnifying glass with a focal length of  $+3$  cm is placed 2 cm above a page of print.
- At what distance from the lens is the image of the page?
  - What is the magnification of this image?
- E10. A concave mirror has a focal length of 22 cm. An object is located 9 cm from the surface of the mirror.
- How far from the mirror is the image of this object?
  - Is the image real or virtual, upright or inverted?
- E11. A concave mirror has a focal length of 18 cm. An object is located 45 cm from the surface of the mirror.
- How far from the mirror is the image of this object?
  - Is the image real or virtual, upright or inverted?
  - Trace three rays from the top of the object to confirm your numerical results.
- E12. A convex mirror has a focal length of  $-15$  cm. An object is located 15 cm from the surface of the mirror.
- How far from the mirror is the image of this object?
  - Is the image real or virtual, upright or inverted?
  - Trace three rays from the top of the object to confirm your numerical results.
- E13. A convex mirror used in a store aisle has a focal length of  $-62$  cm. A person in the aisle is 3.1 m from the mirror.
- How far from the mirror is the image of this object?
  - If the person is 1.7 m tall, how tall is the image viewed in the mirror?
- E14. The objective lens of a microscope has a focal length of 0.6 cm. An object on the microscope slide is placed at a distance of 0.9 cm from the lens.
- At what distance from the lens is the image formed by the objective lens?
  - What is the magnification of this image?
- E15. The objective lens of a telescope has a focal length of 1.5 m. An object is located at a distance of 8 m from the lens.
- At what distance from the objective lens is the image formed by this lens?
  - What is the magnification of this image?
- E16. A telescope has an objective lens with a focal length of  $+69$  cm and an eyepiece with a focal length of  $+2.3$  cm. What is the angular magnification produced by this telescope?
- E17. A telescope that produces an overall angular magnification of  $25\times$  uses an eyepiece lens with a focal length of 1.8 cm. What is the focal length of the objective lens?

## Synthesis Problems

- SP1. A fish is viewed through the glass wall of a fish tank. The index of refraction of the special glass is 1.6, and that of the water in the tank is 1.33. The fish lies a distance of 5 cm behind the glass. Light rays coming from the fish are bent as they pass from the water to the glass, then bent again as they pass from the glass to air ( $n = 1$ ). The glass is 0.3 cm thick.
- Considering just the first interface between the water and the glass, how far behind the glass does the image of the fish lie? (This is an intermediate image formed by the bending of light at just the first surface.)
  - Using this image as the object for the second interface between the glass and air, how far behind the front surface of the glass does this “object” lie?
  - Considering the bending of light at this second interface between the glass and air, how far behind the front surface of the glass does the fish appear to lie?
- SP2. An object is located at the focal point of a positive lens with a focal length of 18 cm.
- What is the image distance predicted by the object–image distance formula?
  - Trace two rays to confirm the conclusion of part a.
  - Will the image be in focus in this situation? Explain.
- SP3. An object with a height of 3.6 cm lies 12 cm in front of a lens with a focal length of 8 cm.
- Using the object–image distance formula, calculate the image distance for this object.
  - What is the magnification of this image?
  - Trace three rays to confirm your conclusions of parts a and b.
  - Suppose this image serves as the object for a second lens that has a focal length of  $+6$  cm. The second lens is placed 9 cm beyond the image serving as its object. Where is the image formed by this second lens, and what is its magnification?
  - What is the overall magnification produced by this two-lens system?
- SP4. An object 4 cm tall is located 30 cm from a concave mirror with a focal length of 15 cm. Because the focal length is half the radius of the curvature, the object is located at the center of curvature of the mirror.
- Using the object–image distance formula, find the location of the image.
  - Calculate the magnification of this image.
  - Is the image real or virtual, upright or inverted?
  - Trace two rays from the top of the object to confirm your results.

- SP5. Suppose a microscope has an objective lens with a focal length of 0.9 cm and an eyepiece lens with a focal length of 2.4 cm. The object is located 1.2 cm in front of the objective lens.
- Calculate the position of the image formed by the objective lens.
  - What is the magnification of this image?
  - If the eyepiece lens is located 1.8 cm beyond the position of the image formed by the objective lens, where is the image formed by the eyepiece lens? (The image formed by the objective serves as the object for the eyepiece.)
  - What is the magnification of this image?
  - What is the overall magnification produced by this two-lens system? (This is found by multiplying the magnifications produced by each lens.\*)

---

\*This is not the usual way of calculating the magnifying power of a microscope. The standard method compares the size of the angle subtended at the eye with and without the use of the microscope (called angular magnification).

## Home Experiments and Observations

- HE1. Fill a clear glass almost to the top with water and insert various objects into the water.
- Do the objects appear to be shorter than their actual length when viewed from above the glass?
  - Do the objects appear to be shorter than their actual length when viewed through the sides of the glass? What distortions do you notice when viewing the objects through the sides?
- HE2. Locate two small plane mirrors like the ones often carried in a purse. Place the two mirrors next to each other, so that they touch along one edge, making an angle of  $90^\circ$  between the two mirrors. Place a small object such as a paper clip in front of the two mirrors.
- How many images do you see in the two mirrors when the angle between the mirrors is a right angle ( $90^\circ$ )?
  - As you decrease the angle between the two mirrors, describe what happens to the number of images you can see.
  - Using the idea that each of the images formed can serve as an object for the other mirror, can you explain your observations? (Ray diagrams may be useful.)
- HE3. If you have a magnifying (concave) mirror available, such as a shaving or makeup mirror, try moving the mirror slowly away from your face.
- Describe the changes in the image of your face as the mirror is moved away from your face.
  - The image should become blurred and indistinct when your face is at the focal point of the mirror. Can you estimate the focal length of the mirror by finding the distance from your face where the image disappears?
- HE4. The passenger-side side-view mirror on most cars is a convex mirror. (The warning that objects may be closer than they appear indicates that the mirror is convex.)
- View some object of known height in the mirror. A friend will serve nicely. Estimate the height of the image viewed in the mirror. What is the approximate magnification produced by the mirror?
  - Using your binocular depth perception, estimate the distance behind the mirror that the image is located. (You first have to convince your brain that the image is behind the mirror.) Estimate also the distance of the object from the mirror. Using these values, calculate the focal length of the mirror. (It should be negative.)
- HE5. If you have access to an overhead projector, examine the device carefully, so that you can describe the optical system involved.
- What optical elements (lenses or mirrors) are present?
  - What is the function of each of these elements? (Holding a white card or stiff paper at various places between the elements when the projector is in use may help you analyze their function.)
  - Can you produce a ray diagram showing how the rays coming from the object (the transparency being viewed) converge or diverge on their way to the screen?





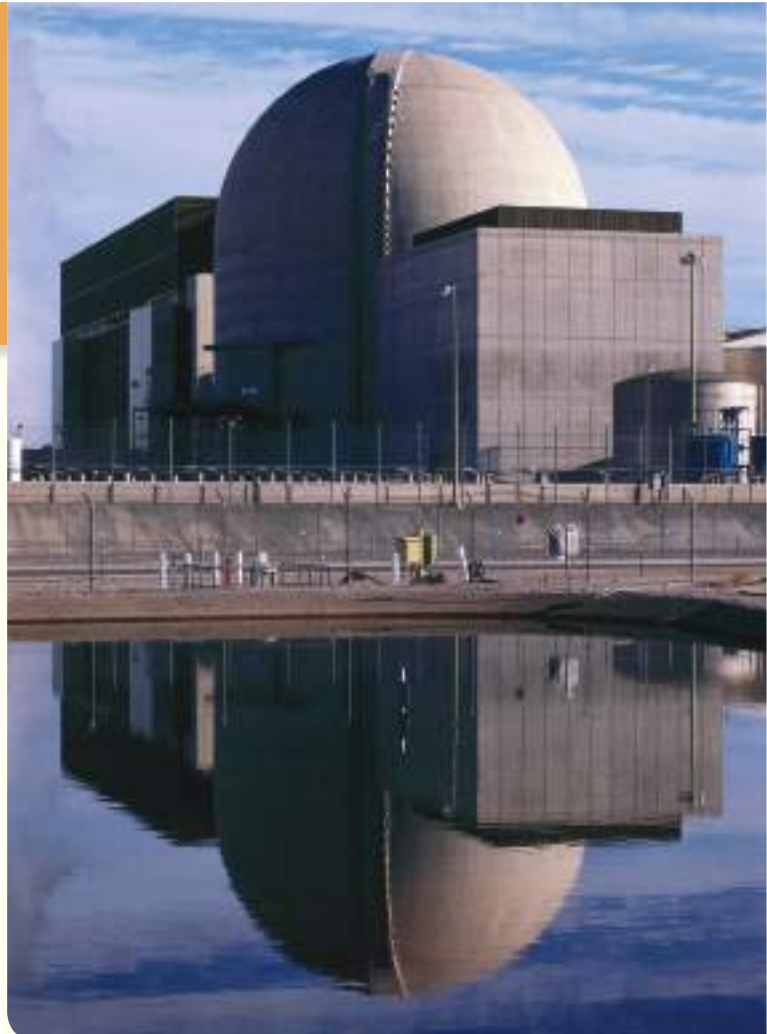
# UNIT 5

## The Atom and Its Nucleus

The idea that matter is made up of tiny particles called atoms has a long history dating at least to the early Greeks, a few hundred years before the birth of Christ. We knew virtually nothing about the structure of atoms, though, until the early part of the twentieth century. In fact, just before the turn of that century, physicists debated whether atoms existed at all—or were merely a convenient fiction used mainly by chemists. At that time, the evidence for the existence of atoms was not overwhelming.

From about 1895 to 1930, a series of discoveries and theoretical developments revolutionized our view of the nature of the atom. We went from knowing almost nothing about the structure of atoms (and even questioning their existence) to a firmly based theory of their structure capable of explaining an enormous range of physical and chemical phenomena. This revolution is surely one of the greatest achievements of the human intellect, with wide-ranging implications for our economy and technology. Its story deserves to be understood by more than a small fraction of our population.

The discovery of the electron in 1897, followed by the discovery in 1911 that an atom has a nucleus, was a critical breakthrough that provided building blocks for atomic models. Niels Bohr's model of the atom put some of these pieces together and stimulated research that led to the more complete and highly successful theory we now call *quantum mechanics*. Quantum mechanics serves as the basis for most work in theoretical physics and chemistry; its detailed predictions about the nature of the atom have spawned many advances in science and technology.



Larry Lee Photography/Getty Images

The nucleus of the atom, that tiny center containing all of the positive charge and most of the atom's mass, has also been found to have an underlying structure. Advances in nuclear physics, discussed in chapter 19, led to the invention of nuclear reactors and nuclear weapons, which thrust physics into world politics. The story of the development of the atomic bomb during World War II is a fascinating mixture of human ingenuity and conflict. Science and world politics have both been irrevocably changed in the process.

The twentieth century saw a revolution in our understanding of the atom and in the role of science in modern life. This revolution may be a mixed blessing, but it cannot be ignored: It involves chemistry and molecular biology, as well as physics. Chapters 18 and 19 look at how this revolution began—but where it will lead us is an open question.



# CHAPTER 18

Charles D. Winters/McGraw-Hill Education

## The Structure of the Atom

### Chapter Overview

Our principal goals in this chapter are to investigate some of the evidence for the existence of atoms and to describe several discoveries that led to an understanding of the structure of atoms. We will begin with evidence from chemistry and proceed to the discoveries of the electron, X-rays, natural radioactivity, the nucleus of the atom, and atomic spectra. We then discuss the Bohr model of the atom and its relationship to the modern view given by the theory of quantum mechanics.

### Chapter Outline

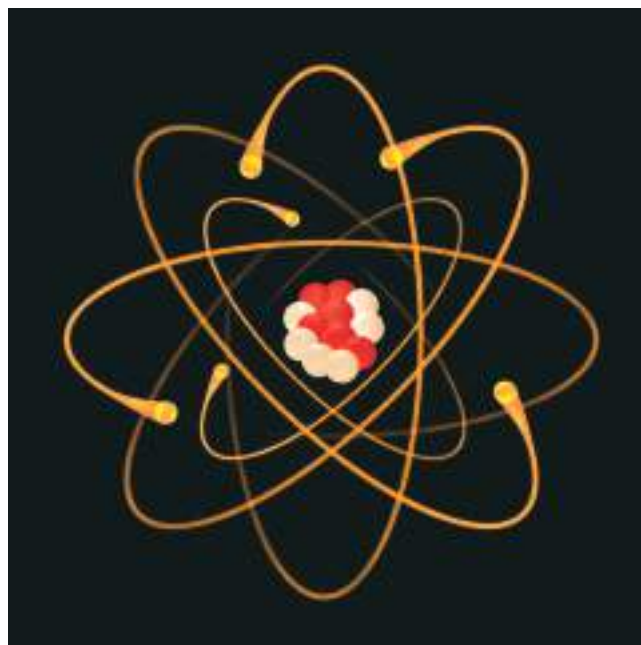
- 1 The existence of atoms: Evidence from chemistry.** What information does the study of chemical reactions offer about the existence and nature of atoms? How was the periodic table of the elements developed?
- 2 Cathode rays, electrons, and X-rays.** How are cathode rays produced, and what are they? How did the study of cathode rays lead to the discovery of the electron and of X-rays?
- 3 Radioactivity and the discovery of the nucleus.** How was natural radioactivity discovered, and what is it? What role did natural radioactivity play in the discovery of the nucleus of the atom?
- 4 Atomic spectra and the Bohr model of the atom.** What are atomic spectra? What role did they play in understanding atomic structure? What are the basic features of Bohr's model of the atom?
- 5 Particle waves and quantum mechanics.** What were the limitations of the Bohr model, and how does the theory of quantum mechanics address these problems? What do we mean when we say that particles have wave properties?

**H**ave you ever seen an atom? You have certainly heard people talk about atoms and have probably seen pictures of atomic models like the one in figure 18.1, but are you aware of how we know that atoms exist? Perhaps the questions that should be posed are “Do you believe in atoms? And if so, why?”

Most of us have accepted the existence of atoms based on the pronouncements of textbooks or teachers dating back to our elementary-school days. You may be shocked to learn that many of those teachers never seriously questioned why they believed in atoms or understood where our evidence for the existence of atoms originated. Why, then, should you believe in atoms or in descriptions of their structure?

Although we cannot see atoms directly and we may not recognize them as part of our everyday experience, atomic phenomena are evident in our everyday world. The operation of a TV, chemical changes that occur in our bodies, the use of diagnostic X-rays, and many other common phenomena can all be understood by relying on our modern knowledge of atomic behavior.

Most importantly, we will consider the question of why we believe in the existence of atoms and in our models of atomic structure. How have these ideas developed? Understanding how our knowledge of the atom originated can make atoms themselves seem more real.



**Figure 18.1** A stylized atom. Does an atom really look like this?  
*Don Farrall/Getty Images*

## 18.1 The Existence of Atoms: Evidence from Chemistry

Why should we believe in the existence of things that we have never personally seen? Why did many nineteenth-century scientists talk with confidence of the existence and properties of the atoms of different substances when they knew nothing about their actual structure? What in our everyday experience points to the existence of the invisible atom?

Much of modern science involves things we cannot see directly. We infer their existence from observations that taken together provide convincing evidence of their behavior and characteristics. In the case of atoms, much early evidence came from the study of chemistry. Chemical processes are very common in our daily life, although we may not give them much thought. If the concept of atoms were not already available, you might have to invent the idea just to explain these phenomena.

### What did early studies in chemistry reveal about atoms?

Chemistry is the study of the differences in substances and how they can be combined to form still other substances. Ancient Greek philosophers tried to identify the elementary substances from which all things are made. Fire, earth, water, and air were the early candidates. Clearly, those choices required some refinement. Earth, in particular, was capable of taking on many forms.



**Figure 18.2** A tablet of food coloring is dropped into a glass of water. How might we explain what happens?  
*Lars A. Niki*

One of the most striking demonstrations in elementary chemistry involves dropping a small tablet of dye or food coloring into a glass of water (fig. 18.2). Rather quickly, the color diffuses, until the originally clear water becomes a uniformly colored fluid. Evidently, a change has taken place, but how might we explain that change?

Even without instruction in the language of chemistry, we might find ourselves thinking that tiny particles of the dye migrate in the water and move between particles of the water through spaces that are not apparent. Similar explanations might account for the disappearance of sugar or salt when placed in water or other fluids.

We also know that almost any solid substance can be crushed into a fine powder. By subjecting that powder to heat (or fire), we often can form a solid again, although perhaps modified compared to the original substance. If the powder is combined with some other powdered substance and heated, the resulting product can be quite different from either of the original substances. Baking is a familiar example of that process, but experiments in refining and modifying metals may have been the most important examples in early chemistry. Alchemists were enticed by the elusive prospect of making gold from more common metals.

Is it possible to reduce something into a powder of ever-smaller particles? Early scientists were tempted to think that this was not the case. Because certain elementary substances always seemed to be retrievable from their experiments, they assumed that irreducible particles of these substances retained their form. The notion that each of the elementary substances, or **elements**, was made up of tiny particles, or **atoms**, was an attractive model for explaining chemical phenomena. Such atoms might then combine with atoms of other elements to form different substances but could always be retrieved from these substances by sufficient heating or other processes.

Systematic study of how elements combined with each other revealed regularities and rules that formed the basis of early chemical knowledge. Clearly, certain elements were more alike in their properties and reactions than others. Elements could thus be grouped, or classified, which further suggested that the atoms of these elements must have similarities in structure. The details of that structure, and even the size of the atoms, were completely unknown and seemingly inaccessible.

### Is mass conserved in chemical reactions?

The birth of modern chemistry is often dated to the work of French scientist Antoine Lavoisier (1743–1794). Lavoisier discovered that the total mass of chemical reactants and products is conserved in chemical reactions. This discovery established the importance of weighing the reactants and products, which has since become a routine procedure in most chemical experiments.

Although the idea that mass is conserved in chemical changes might seem self-evident now, conservation of mass was not at all clear in Lavoisier's time. The reason was simple: Most chemical experiments were performed in open air, and oxygen and other gases in the air were involved in the reactions. Because the quantities of these reacting gases were not recognized and measured, the masses of the solid or liquid substances in the reactions did not seem to be conserved. Air itself is not a simple substance, a fact only beginning to be understood at that time.



**Figure 18.3** Burning wood is a chemical reaction. What substances are reacting? What is produced?

vgajic/E+/Getty Images

One of the most common of all chemical reactions is the burning, or **combustion**, of carbon compounds such as wood or coal (fig. 18.3). That reaction combines oxygen from the air with the carbon in the coal or wood to form carbon dioxide (a gas) and water vapor (also a gas). If we are not aware of the role of the gases, we can be easily misled into thinking we have lost some mass during combustion.

Lavoisier performed a series of experiments in which he carefully controlled and weighed the quantities of gas that participated as either reactants or products. The results of these experiments showed clearly that the total mass of the products was equal to the total initial mass of the reactants—no mass was lost or gained. In the process, he was able to distinguish oxygen (or “highly respirable air”) from carbon dioxide and water vapor and to provide the first accurate description of combustion reactions. The results of this work were published in 1789 as the *Traité Élémentaire de Chimie* (*Elementary Treatise of Chemistry*).

### How did the concept of atomic weight emerge?

Although Lavoisier's brilliant career was tragically cut short (literally) when he lost his head to the guillotine in the French Revolution, his discoveries were soon followed by another important insight from English chemist John Dalton (1766–1844). Dalton tried to make sense of the regularities observed in the ratios of weights of chemical reactants and products. Dalton's ideas depended heavily on the experimental work of other chemists, who were engaged in the new practice established by Lavoisier of carefully weighing all reactants and products.

Dalton was intrigued by the fact that when a chemical reaction took place, the reactants always seemed to combine in the same proportions by mass. For example, when carbon combined with oxygen to form the gas now called carbon dioxide, the ratio of the mass of oxygen to the mass of carbon that would react was always the same: 8 to 3. In other words, if

3 grams of carbon were involved, 8 grams of oxygen were required to complete the reaction, no more and no less. If more than 8 grams of oxygen were present, some were left over; if less than 8 grams were present, some carbon was left over.

This idea of specific mass ratios held for other reactions, although with different ratios for each reaction. When hydrogen combines with oxygen to form water, the mass ratio is 8 to 1. That is, 8 grams of oxygen are required to react completely with 1 gram of hydrogen. Each reaction required a specific proportion to react completely. This observation is often referred to as **Dalton's law of definite proportions**.

Dalton recognized that a model using atoms explained these observations. Dalton thought that each element was made up of tiny atoms, which were all identical in mass and form, but that different elements had different atomic masses. A chemical compound might then be the combination of a few atoms of one element with a few atoms of another to form **molecules**—several atoms of different elements bound together somehow. The characteristic masses of the atoms were responsible for the regular ratios of mass observed in the reactions.

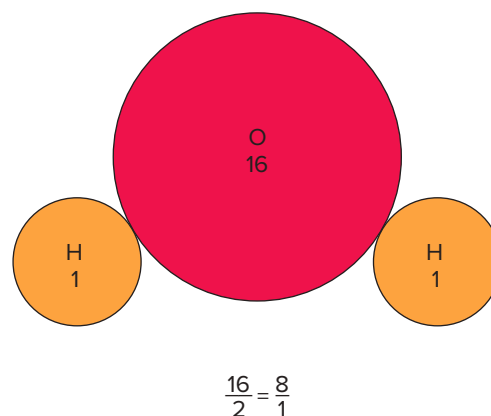
This idea is illustrated in figure 18.4. Suppose (as we now know) that the chemical compound of water is formed by two atoms of hydrogen combining with one atom of oxygen to form a water molecule ( $\text{H}_2\text{O}$ , in modern notation). If the mass of an oxygen atom is 16 times the mass of a hydrogen atom, this would account for the observed proportion of oxygen to hydrogen of 8 to 1 (16 to 2), because each water molecule has two atoms of hydrogen for every one of oxygen.

When different atoms or molecules interact to form new molecules, we call this a chemical reaction. The reaction in which oxygen combines with hydrogen to form water is discussed in everyday phenomenon box 18.1. In a chemical reaction, the atoms of elements combine in different ways but do not change their fundamental nature. However, the chemical compounds that result can appear very different from the original reactants.

The 8-to-3 proportion for the carbon dioxide reaction can likewise be explained if the carbon atom has a mass 12 times that of hydrogen, and two atoms of oxygen (each one 16 times the mass of hydrogen) combine with one atom of carbon to form a carbon dioxide molecule ( $\text{CO}_2$ ). See example box 18.1. Carbon dioxide is a greenhouse gas, as discussed in everyday phenomenon box 10.2, and is produced whenever we burn a carbon-based fuel such as wood, coal, oil, or natural gas.

One reaction by itself is not enough to establish the relative atomic masses, but the study of several reactions provides a consistent picture, which Dalton showed in his treatise *A New System of Chemical Philosophy*, published in 1808.

Dalton's atomic hypothesis did not establish the actual mass of individual atoms—he still did not know how large one atom was. Dalton's hypothesis is a means of determining the masses of the atoms of one element relative to those of another, a task that occupied chemists through much of the remainder of the nineteenth century. Like any good theory, Dalton's model was a productive guide for further



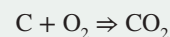
**Figure 18.4** Two atoms of hydrogen combine with one of oxygen to form water ( $\text{H}_2\text{O}$ ). The mass ratio is 8 to 1, because the atomic mass of oxygen is 16 times the mass of hydrogen.

### Example Box 18.1

#### Sample Exercise: Burning Carbon

If 30 g of pure carbon are burned (combined with oxygen) to form carbon dioxide, how many grams of oxygen will be consumed in this reaction? Carbon has an atomic mass of 12, and oxygen has an atomic mass of 16.

$m_c = 30$  g      The reaction can be described by the reaction equation  
 $m_o = ?$



where the notation  $\text{O}_2$  indicates that two oxygen atoms are normally combined to make an oxygen molecule in oxygen gas. The ratio of the mass of oxygen to that of carbon,  $R_{o/c}$ , is then

$$R_{o/c} = \frac{2(16)}{12}$$

$$R_{o/c} = \frac{32}{12}$$

$$R_{o/c} = \frac{8}{3}$$

so that

$$\frac{m_o}{m_c} = R_{o/c}$$

$$m_o = (R_{o/c})(m_c)$$

$$m_o = \left(\frac{8}{3}\right)(30 \text{ g})$$

$$m_o = \mathbf{80 \text{ g}}$$

chemical research. It also presented the concept of atoms in a new and more detailed light: Some atoms are heavier than others, and **atomic mass** is a property of an element.

## Everyday Phenomenon

## Box 18.1

## Fuel Cells and the Hydrogen Economy

**The Situation.** Most of the energy used by modern industrial societies comes from fossil fuels—oil, natural gas, and coal. Each of these fuels produces significant amounts of pollution. They also produce carbon dioxide, a greenhouse gas that contributes to global warming. Fossil fuels are nonrenewable, which means there is a limited amount of oil, natural gas, and coal. This may lead to irreversible shortages in the near future, especially in the case of oil.

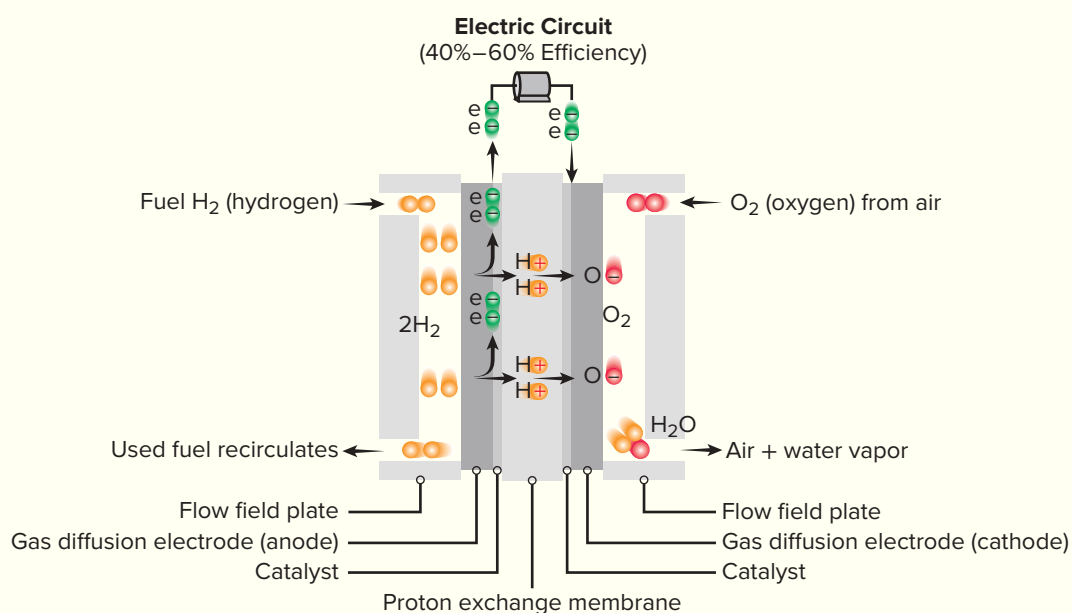
Are there alternatives to fossil fuels without these drawbacks? Many scientists and engineers have proposed switching to a “hydrogen economy” in place of our current oil-based economy. The fuel cell, a device invented in the nineteenth century and developed by NASA to power space vehicles, combines hydrogen and oxygen to produce electricity and water. Is it feasible for this pollution-free, energy-producing technology to replace internal combustion engines that use oil-based fuels?

**The Analysis.** A hydrogen fuel cell converts hydrogen and oxygen into water and generates electricity in the process. A fuel cell is similar to a battery in that it uses a chemical reaction to produce electricity. However, for a battery, the chemicals are stored internally, while hydrogen and oxygen are stored externally from the fuel cell and can be replenished to produce electricity until the fuel cell wears out. There are several types of fuel cells, but the proton exchange

membrane (PEM) fuel cell is the most promising type for use in cars and trucks.

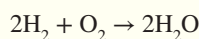
The PEM fuel cell consists of several components: the anode, the cathode, the proton exchange membrane, and the catalyst (see the diagram). The anode and cathode are where chemical reactions take place. The proton exchange membrane is a thin, specially treated material that allows only protons to pass through it and blocks electrons. The PEM is sandwiched between the anode and the cathode. A catalyst is a substance that speeds up a chemical reaction without being consumed by the reaction. For the PEM fuel cell, the catalyst is platinum powder thinly coated on carbon paper. The powder provides a large surface area on which the hydrogen and oxygen can react. Both the anode and the cathode are covered with the catalyst.

How does the fuel cell work? Hydrogen gas is fed to the anode. A hydrogen atom contains one positively charged proton and one negatively charged electron. Hydrogen gas consists of hydrogen molecules, which are denoted by  $H_2$  because they are composed of two individual hydrogen atoms bound together. When an  $H_2$  molecule comes in contact with the platinum catalyst at the anode, it reacts chemically and splits into two protons and two electrons. Both the protons and the electrons are attracted to the oxygen at the cathode. However, the PEM allows only the protons through to the cathode and blocks the electrons. In order for the electrons to get to the cathode, they travel



Hydrogen gas is supplied to the fuel cell. The proton exchange membrane allows the positive hydrogen ions (protons) to flow across the membrane, but the electrons must travel through the external circuit. The exhaust is water vapor.

through a circuit from the anode through an electric motor or other device to the cathode. These electrons provide the electric current that powers the motor. When the protons and electrons arrive at the cathode via their different routes, they come in contact with the catalyst and react with oxygen molecules to form water. If oxygen is not supplied to the cathode, the protons and electrons are not attracted to it. Fortunately, the fuel cell can use oxygen that exists in air. The overall net chemical reaction is



Notice that there are four hydrogen atoms and two oxygen atoms on both sides of this equation, so the chemical reaction is balanced. Many instances of this reaction occur simultaneously, so a large number of electrons are produced to provide power for the electric motor. Because a single fuel cell cannot provide enough power to drive a car, a stack of fuel cells is used.

It all sounds wonderful—a pollution-free device that produces only electricity and water to run our cars. Indeed, NASA has been using fuel cells for years to power space vehicles, so fuel cells are effective and reliable. Unfortunately, there are serious practical challenges that must be overcome before hydrogen fuel cells can be widely used in place of internal combustion engines.

Research and development has been going on for many years, and much progress has been made. Hydrogen cells have become larger and more reliable, with more lasting structures. However, a lot of work will be needed to make hydrogen fuel cells suitable as a large-scale replacement for fossil fuels. Hydrogen cannot be mined or drawn out in large quantities from the small amount contained in the atmosphere.

Hydrogen is usually obtained by separating it from water ( $\text{H}_2\text{O}$ ) by the use of electric power. In other words, hydrogen is not an original source of energy; like batteries, the energy needed must come from other electrical sources. Batteries and fuel cells are means of storing and transporting electric power.

Fuel cells have an advantage of less weight than batteries and longer distances of travel before refueling is needed. They also take much less time for refueling than batteries. As we develop fuel-cell cars and trucks, we will need to develop more recharging stations and a comprehensive hydrogen refueling system. Hydrogen fuel cells are a promising technology, but it will take many years to create an infrastructure for widespread use in trucks and other vehicles.

Table 18.1 compares the masses of the atoms of several common elements. Traditionally referred to as *atomic weight*, atomic mass is a more appropriate term, given our distinction between mass and weight. A complete list is found in the periodic table in appendix E. Note that many of the relative masses are approximately whole numbers, but others are not. Therein lay another intriguing mystery and a clue to the structure of the atom.

**Table 18.1**

Atomic Masses of Some Common Elements Compared, Given in Atomic Mass Units (u)

Element	Chemical Symbol	Atomic Mass (u)
Hydrogen	H	1.01
Helium	He	4.00
Carbon	C	12.01
Nitrogen	N	14.01
Oxygen	O	16.00
Sodium	Na	22.99
Chlorine	Cl	35.45
Iron	Fe	55.85
Lead	Pb	207.20

## Debatable Issue

A few years ago, there was a lot of political hype about the advantages of the so-called hydrogen economy, in which hydrogen fuel cells would replace gasoline engines in automobiles. Although hydrogen itself is abundant, it must be separated from water or natural gas by processes that utilize more energy than can be recovered in fuel cells. Should we be considering a large-scale changeover to a hydrogen economy?

## How was the periodic table developed?

As chemists gathered more and more information on the atomic masses and chemical properties of the various elements, some other interesting regularities began to emerge. It had been known for some time that families of elements displayed similar chemical properties. Chlorine (Cl), fluorine (F), and bromine (Br) (called *halogens*), for example, formed similar compounds when combined with highly reactive metals, such as sodium (Na), potassium (K), or lithium (Li) (*alkali metals*). The atomic weights of the elements within any given family, however, were very different.

When all of the elements were listed in order of increasing atomic weight, the members of a family seemed to pop up at more-or-less regular intervals in the list, particularly



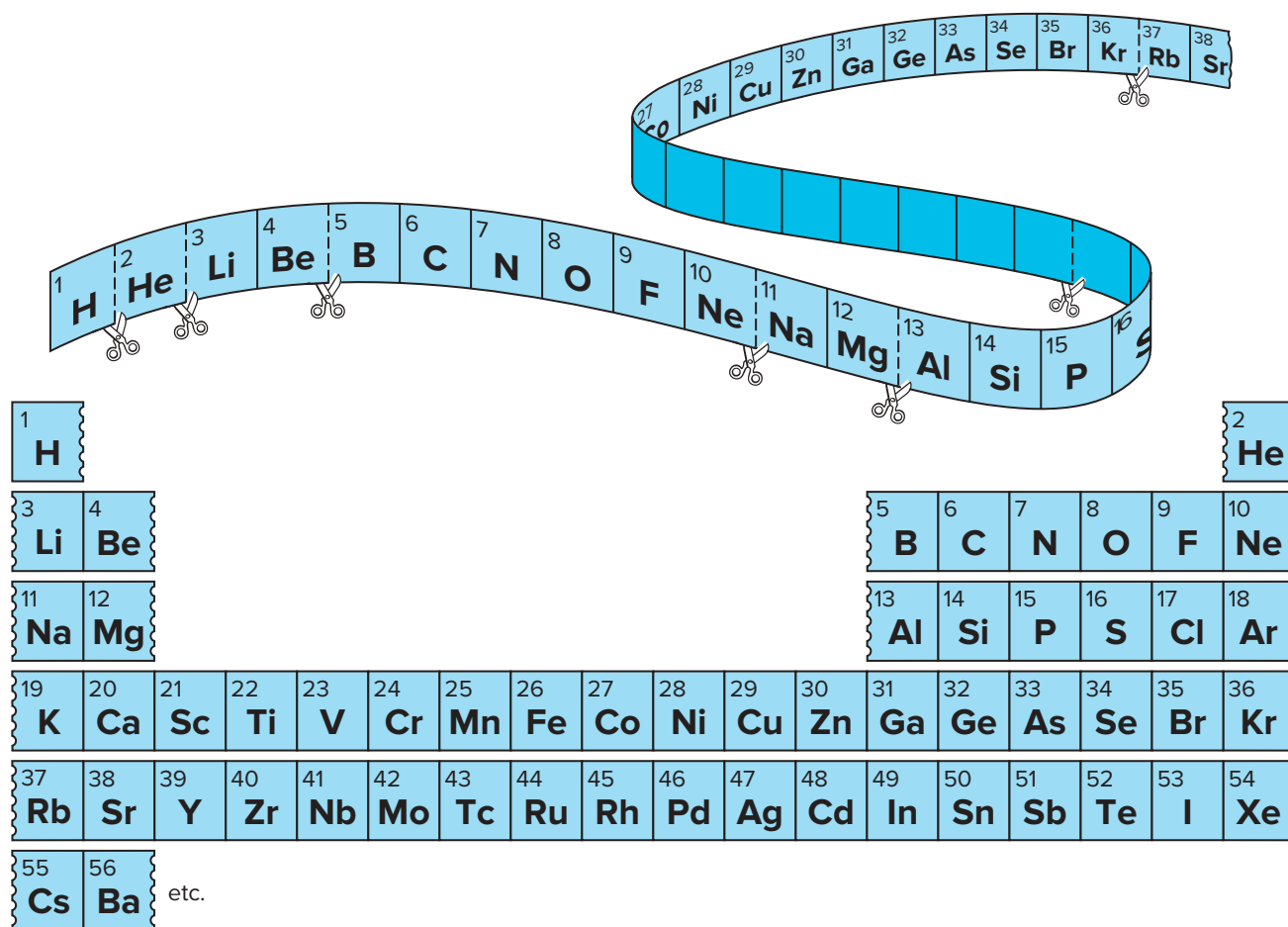
the lighter elements. Although others had tried to make sense of these periodicities, the person who succeeded in producing the most useful organization was Russian chemist Dmitri Mendeleev (1834–1907). Mendeleev's scheme, first published in 1869, is now called the **periodic table of the elements**.

To understand Mendeleev's table, imagine listing all of the known elements by increasing atomic weight on a long strip of paper. Then, to make the table, we cut the strip at various points and lay the strips out in rows. We begin by cutting at every place that we encounter an alkali metal in the list. We line these strips up in our table so that the alkali metals all lie in a column on the left side of the table (fig. 18.5).

To get the halogens to line up, we need to cut the remaining strips again, somewhere near their midpoints, because there are more elements in some rows than in others. The halogens are also arranged above one another in a column near the right side of the table. In Mendeleev's original

table, the halogens formed the column on the far right, because the noble gas elements [helium (He), neon (Ne), Argon (Ar), krypton (Kr), xenon (Xe), and radon (Rn)] had not yet been discovered. In the finished table, elements with common chemical properties line up in columns above one another, but the order of atomic weights is preserved in the rows and throughout the table. (See the complete periodic table in appendix E.)

Although the periodic table was an intriguing way of organizing knowledge of the chemical elements, it raised more questions than it answered. Atoms of the elements in a given column must somehow have similar properties, but chemists still knew virtually nothing about the structure of atoms. They were driven to drawing little hooks and rings on their atoms as they attempted to explain how atoms combined, but they knew that these pictures were unlikely to be accurate. A body of knowledge was building that called for explanation, but the explanation did not come until the early part of the twentieth century.



**Figure 18.5** The periodic table can be formed by listing the elements in order of increasing atomic weight and then cutting the list at certain points. Elements with similar chemical properties are then aligned in columns.

From many observations on how substances combine to form other substances, scientists speculated that each different substance consisted of tiny particles, or atoms, with properties characteristic of that substance. Lavoisier's discovery of the conservation of mass in chemical reactions established the importance of weighing the reactants and products. Dalton's law of definite proportions introduced the property of atomic weight for atoms of different substances. The periodic table of the elements was developed by Mendeleev in the 1860s. He listed the elements in rows of increasing atomic weight and then divided the list into rows, so that elements with similar properties sat above one another in the columns. These regularities suggested recurring similarities in atomic structure.

## 18.2 Cathode Rays, Electrons, and X-rays

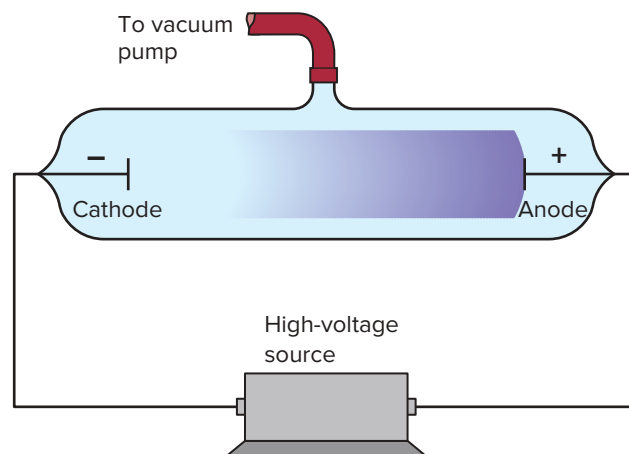
By the end of the nineteenth century, chemists were quite comfortable with the concept of atoms and knew a good deal about their relative masses and properties, if not their actual structure. Physicists, on the other hand, were less convinced. Many physicists were not aware of the details of the chemical evidence, and some even denied that atoms existed.

Near the end of the nineteenth century, several discoveries were made in physics that would prove crucial to understanding atomic structure. This part of the story begins with the study of *cathode rays*, the focus of much curiosity and research in the latter half of the century.

### How are cathode rays produced?

Until recently, when plasma or liquid crystal displays became commonly used, the heart of most TV sets was a cathode-ray tube (or CRT, as it is known in the electronics industry). The discovery of cathode rays resulted from merging two different technologies: the ability to produce good vacuums with improved vacuum pumps and the growing understanding of electrical phenomena. (The cathode-ray tube used in an older TV is described in everyday phenomenon box 18.2.)

Johann Hittorf (1824–1914) was one of the first to observe cathode rays. In a paper published in 1869, he described in detail what happens when a high voltage is placed across two electrodes sealed in a glass tube connected to a vacuum pump (fig. 18.6). As the air is pumped out of the tube, a colorful glow first appears in the gas near the *cathode*, the negative electrode. As the gas pressure in the tube is reduced, the glow spreads through the entire volume between the two electrodes. The colors of this glow discharge depend on the kind of gas originally in the tube.



**Figure 18.6** A simple cathode-ray tube consists of two electrodes sealed in a glass tube. A glow discharge appears in the gas between the electrodes as the tube is evacuated. With further evacuation, the discharge disappears, and a glow appears on the end of the tube opposite the cathode.

As the tube is evacuated to still lower pressures, the glow discharge disappears. A dark region starts to form near the cathode and then moves across the tube toward the *anode*, the positive electrode, as the pressure is further reduced. When the dark region has moved completely across the tube, a new phenomenon appears. Instead of the gas glowing, there is now a faint glow on the glass wall of the tube opposite the cathode.

Because the darkening began near the cathode and spread across the tube, scientists surmised that something emitted from the cathode was responsible for the glow on the opposite wall of the tube. For this reason, the invisible radiation was called **cathode rays**.

One of the simpler experiments that can be performed with cathode rays is deflecting the beam with a magnet. If cathode rays are focused into a narrow beam by appropriate shaping and positioning of the cathode and anode, the beam can be moved around with a magnet. If the north pole of a magnet is brought down from the top, as in figure 18.7, the spot of light created by the beam is deflected to the left on the face of the tube. This result is consistent with the assumption that the cathode rays are negatively charged particles, which you can confirm using the right-hand rule for magnetic forces introduced in chapter 14.

### What is the makeup of cathode rays?

The questions about the nature of cathode rays were largely resolved by J. J. Thomson (1856–1940). Thomson performed a series of experiments to measure the masses of the negatively charged particles thought to be present in the cathode-ray beam. In one experiment, Thomson passed

## Everyday Phenomenon

## Box 18.2

## Television Development

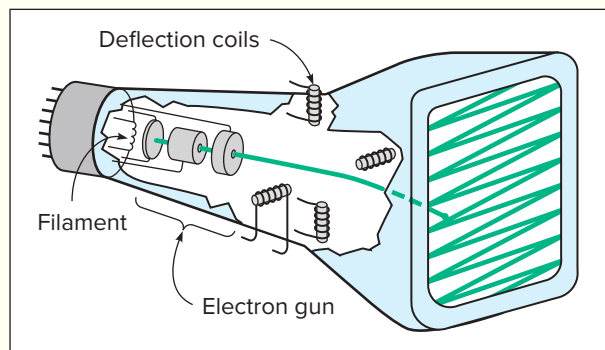
**The Situation.** Television has played an enormous role in modern life. It is the primary source of entertainment and news for many people, although cell phones have joined in that role. Older people have experienced a huge change in television technology during their lifetimes.



Friends enjoying a sporting event on a television set.  
Vasyi Shulga/Shutterstock

The flat-panel TVs available now have largely replaced the older and bulkier sets that were common until the early twenty-first century. For over 60 years before that, cathode-ray tubes (CRTs) were the basic technology in television sets. How did the CRTs work, and how did flat-panel TV technology take over?

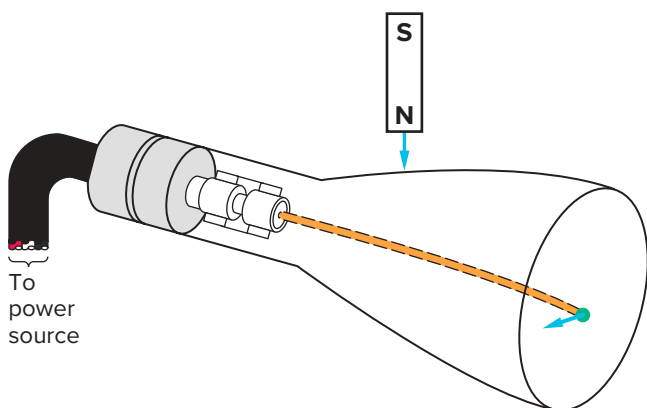
**The Analysis.** Until flat-panel TVs came to dominate the market, the cathode-ray tube was the heart of most television sets. The CRT itself was first developed in the early 1900s and was used for various scientific experiments. Very early TV sets were developed in the 1920s but did not reach commercial use until the 1940s.



A cut-away view of a CRT shows the electron gun and other electrodes used to deflect the beam to different points on the screen.

A simplified drawing of a CRT used in early television is shown in the second figure. The electrodes are all in the back end of the tube. The cathode (negative electrode) lies just in front of a filament that heats the cathode. The anodes (positive electrodes) lie beyond the cathode and have holes in the center. Electrons are attracted to the anodes, which accelerate and focus the electrons. These electrodes form the electron gun that produces a narrow electron beam.

After leaving the electron gun, the beam crosses the tube and produces a bright spot on the front surface of the tube. The surface is generally coated with a phosphor to enhance the brightness. Deflection coils in front of the gun are used to move the beam from place to place on the tube surface, making a zig-zag pattern of varying brightness on the screen. This process is repeated 30 times a second, creating the changing picture that we see.



**Figure 18.7** If the north pole of a magnet is brought down toward the top of a cathode-ray tube, the spot of light is deflected to the left across the face of the tube.

the beam through crossed electric and magnetic fields of known strength (fig. 18.8). The combined effect of the electric and magnetic fields on the beam allowed him to estimate the velocity of the particles, because the magnetic force depends on velocity, but the electric force does not.

Knowing the velocity and the extent of deflection produced by the magnetic field alone, he could estimate the mass of the particles. By Newton's second law, the acceleration of the particles by the magnetic force that causes their deflection is inversely proportional to their mass. Because the magnetic force ( $F = qvB$ ) also depends on the charge of the particles, which was not known, he actually ended up measuring the ratio of the charge to the mass,  $q/m$ . He published the results of this work in 1897.

The striking features of Thomson's results were the apparently small mass of these particles and the fact that all of them seemed to have the same ratio of charge to mass, which

The first commercial television set was sold in 1939. Various television programs began appearing after World War II, generating considerable public interest. By the early 1950s, television had become a popular feature in many homes. The images were black and white and the sets had relatively small screens, but the programs and news were enjoyed by many people. Color TV became available in the early 1960s.

Many improvements were made over the next 40 years. Bigger screens and higher resolution became common. In the early 2000s, CRTs were still the normal technology. In 2004, however, the first flat-panel TVs appeared on the market, and in just a few years they dominated it.

Work on flat-panel screens was being developed from the 1960s for a variety of uses, including large displays and computer screens. The technology that made flat panels viable for television, however, was the miniaturization of semiconductor electronics (see section 21.3).

Several methods were tried for designing flat-panel displays for use in computers, signs, and other devices. One example is the light-emitting diodes (LEDs) that are now used in lightbulbs, flashlights, and many other applications. LEDs are semiconductor devices that have been miniaturized to tiny lights of varying colors for use in visual displays.

Another method involved liquid crystal displays (LCDs), which are now used in commercial television sets. A liquid crystal flows like a liquid, but the molecules are aligned in directions that are similar to the behavior of crystals. These alignments of the molecules can be changed quickly by electronic signals.

In flat-panel TVs, both LCDs and LEDs are often used. LCDs in small arrays can be turned on or off by electronic signals, and



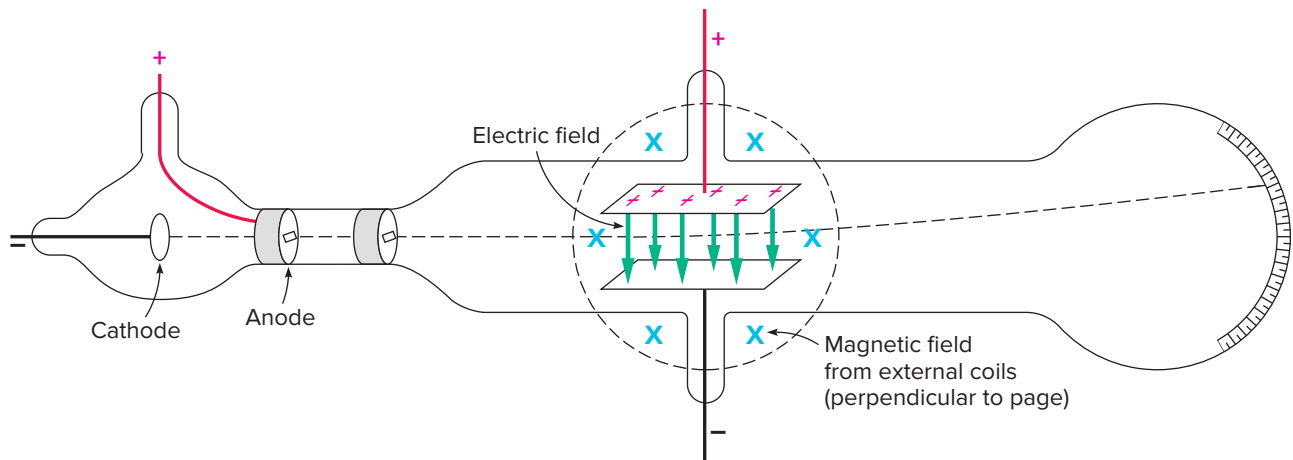
A modern widescreen TV with LCD monitor.  
*cobalt/123RF*

LEDs provide the light and color from behind the LCD array or from the side. All of this takes place in tiny spots behind the screen, providing high resolution. The details of these systems are well beyond what can be described here, and they continue to improve.

Flat-panel displays are used in many different devices besides TVs. They are in cell phones, computer screens, watches, hand-held calculators, and many other gadgets. Technological innovations continue at an amazing rate, creating new devices that were science-fiction ideas a short time ago.

suggested that the particles were identical. The lightest element in the periodic table is hydrogen. If hydrogen ions and cathode-ray particles had the same charge, the mass of the hydrogen atom was nearly 2000 times larger than the mass of a cathode-ray particle.

Not only were these particles identical for a given cathode, they had the same charge-to-mass ratio even if the cathode was made of a different metal. Thomson checked this result by repeating the experiment with cathodes made of various metals. The same particles seemed to be present



**Figure 18.8** Thomson used both electric and magnetic fields to deflect the cathode-ray beam in a tube specially designed to measure the mass of the cathode-ray particles.

in all those that he tested. This fact, together with their small mass, suggested that these particles must be common constituents of different types of atoms.

We now call the negatively charged particles of the cathode-ray beam **electrons**, and Thomson is credited with discovering the electron in these experiments. A cathode-ray beam is a beam of electrons. Each electron is now known to have a mass of  $9.1 \times 10^{-31}$  kg and a charge of  $-1.6 \times 10^{-19}$  C. Thomson's discovery provided the first known *subatomic* particle, a particle smaller than the smallest known atom. The electron became the first possible candidate for a building block of atoms.

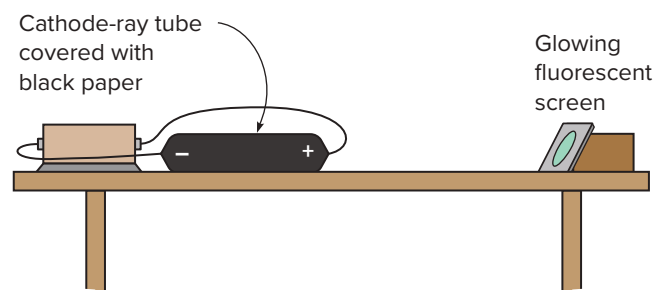
### How were X-rays discovered?

The study of cathode rays produced other dividends besides the discovery of the electron. A German physicist, Wilhelm Roentgen (1845–1923), discovered another type of radiation associated with the cathode-ray tube, one that created a sensation in both the popular press and the scientific community.

As is often the case, Roentgen made his discovery partly by accident. For reasons he never made completely clear, he was experimenting with a cathode-ray tube that he had covered with black paper. Nearby, on his workbench, was a piece of paper coated with a fluorescent material, barium platinocyanide. Roentgen noticed that the paper glowed in the dark when the cathode-ray tube was turned on, even though no light was escaping from the tube (fig. 18.9). The glow stopped when the tube was turned off.

It was already well known that cathode rays could not travel far in air—nor could they travel through the glass walls of the tube. The fluorescence, though, appeared even when the paper was located as far as 2 meters from the tube. The new radiation causing the fluorescence could not be the cathode rays. Not knowing exactly what they were, Roentgen called them **X-rays**, because the letter *X* is often used to represent an unknown quantity.

The most striking feature of these X-rays was their penetrating power. They apparently passed readily through the glass walls of the tube, as well as through other obstacles in their path. In some of his earliest experiments, Roentgen showed that he could produce a shadow of the bones in his hand by placing his hand between the end of



**Figure 18.9** Roentgen noticed that a fluorescent material glowed when placed near his covered cathode-ray tube. The glow appeared only when the cathode-ray tube was turned on.



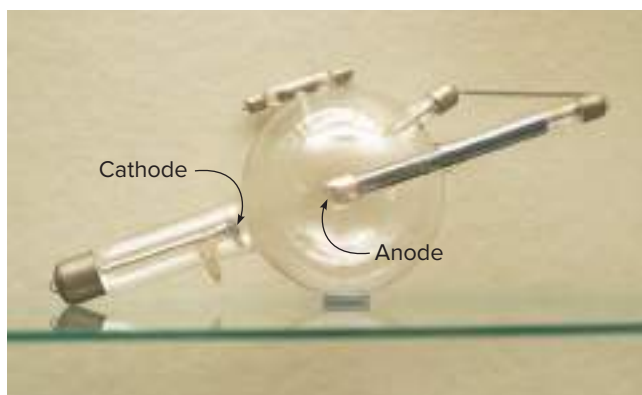
**Figure 18.10** Roentgen discovered that a shadowgram of the bones in a hand could be produced by passing X-rays through the hand. Bettmann/Getty Images

the cathode-ray tube and the fluorescent screen (fig. 18.10). He also showed that the X-rays were capable of exposing a covered photographic plate. He took pictures of the outlines of brass weights inside a wooden box. Roentgen published the results of his initial experiments with X-rays in 1895.

This ability to “see” through objects opaque to visible light excited the imagination of the popular press. Everyone, scientists included, wanted to see an X-ray tube at work. Within a year, doctors were using X-rays to take pictures of broken bones and other dense tissue. Unfortunately, they knew little about the hazards of repeated exposure to X-rays, so many doctors and dentists suffered from severe radiation effects in the early years of their use.

Roentgen performed an extensive series of experiments with his newly discovered radiation as he tried to ascertain what it was. As a result of the work done by Roentgen and other scientists, it was eventually determined that X-rays are a form of electromagnetic wave with very short wavelengths and very high frequencies (see section 16.1 and fig. 16.5). X-rays are produced by collisions of the cathode rays (electrons) with the walls of the cathode-ray tube or with the anode of the tube. The strongest X-ray beams are produced by placing the metal anode at a  $45^\circ$  angle to the electron beam and using high voltages to excite the tube (fig. 18.11).

The discovery of X-rays was important to medicine as well as to physics. It led directly to the discovery of yet another kind of radiation and thus furthered the exploration of the atom's structure. This new type of radiation, called *natural radioactivity*, actually is three distinct forms of radiation. In section 18.3, we will describe how this discovery provided a powerful probe for getting inside an atom.



**Figure 18.11** An X-ray tube in a diagnostic X-ray machine uses an angled anode to project X-rays through the side of the tube.  
*James Ballard/McGraw-Hill Education*

Cathode rays are produced by placing a high voltage across two electrodes sealed in an evacuated tube. Experiments with these rays showed that they were composed of negatively charged particles (now known to be electrons), all having an identical charge-to-mass ratio. The mass of these particles apparently was smaller than the mass of the smallest atom, and they seemed to be present in different types of metal, which suggested that they could be constituents of all atoms. Study of cathode rays also resulted in the discovery of X-rays, which are highly penetrating electromagnetic waves with a very short wavelength. This discovery, in turn, led to the discovery of natural radioactivity and the nucleus of the atom.

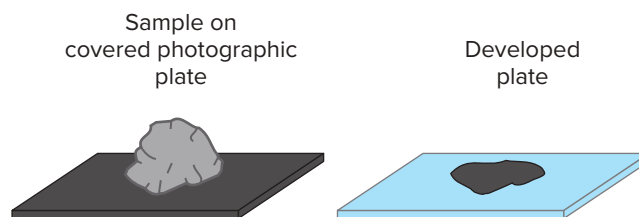
## 18.3 Radioactivity and the Discovery of the Nucleus

Most of us have heard of radioactivity and perhaps have come to fear it because of publicity about nuclear power, nuclear weapons, and radon in our homes and other buildings. For most of the time that humans lived on Earth, however, we were blissfully unaware of its presence. How was radioactivity discovered, and how did that lead to the discovery of the nucleus of the atom? The fields of atomic and nuclear physics, which did not exist before the beginning of the twentieth century, arose from these events.

### How was radioactivity discovered?

A French scientist, Antoine-Henri Becquerel (1852–1908), discovered natural radioactivity in 1896. His experiments were directly motivated by Roentgen's discovery of X-rays the previous year. For many years, Becquerel had studied phosphorescent materials, which glow in the dark after being exposed to visible or ultraviolet light. Many of the phosphorescent materials that Becquerel was studying were compounds containing uranium, the heaviest element known at that time.

Becquerel wondered whether penetrating radiation (like Roentgen's X-rays) was emitted by his phosphorescent



**Figure 18.12** When Becquerel placed a piece of phosphorescent material on a covered photographic plate, the developed plate showed a silhouette of the sample, indicating that the plate had been exposed by radiation passing through the black paper cover.

compounds. He tried a simple experiment in which he exposed some of these compounds to sunlight for a while and then placed them on top of photographic plates wrapped in black paper, so that no light could reach them. Sure enough, the photographic plates were exposed near the pieces of phosphorescent material (fig. 18.12). Radiation apparently was passing from these materials through the black paper to expose the film.

Although this was an interesting discovery in itself, there was more to come. Further experiments by Becquerel showed that not all phosphorescent materials could expose a photographic plate, only those that contained uranium or thorium. Furthermore, somewhat by accident, Becquerel discovered that it was not necessary to expose these materials to light to produce the effect. Becquerel had prepared samples one day, intending to expose them to sunlight. The sun was not shining that day, however, so he put them away in a drawer for a few days, together with the covered photographic plate. When he returned to the project several days later, he decided to develop the plate before proceeding, just to be safe, fully expecting that it would not be exposed. To his great surprise, he discovered that the plate was very heavily exposed near the uranium samples. Apparently, earlier exposure to sunlight (necessary for phosphorescence) was not needed to produce the radiation that was exposing the plates.

Becquerel was even more surprised to discover that the uranium samples retained the ability to expose film indefinitely, even if kept in a dark box or drawer for weeks. The phosphorescent effect, on the other hand, disappeared swiftly (in just a few minutes) after the samples were removed from the source of light. The penetrating radiation coming from his uranium samples did not seem to be connected with the phosphorescence at all.

Becquerel named this new radiation **natural radioactivity**, because it seemed to be produced continuously by compounds containing uranium or thorium without a need for special preparation. Natural radioactivity puzzled physicists of that time, because there was no apparent source of energy to produce the radiation. Where did these rays come from? How could rays continue to be emitted when no energy was being added to the samples in any obvious manner? Was this radiation somehow a property of the atoms themselves?

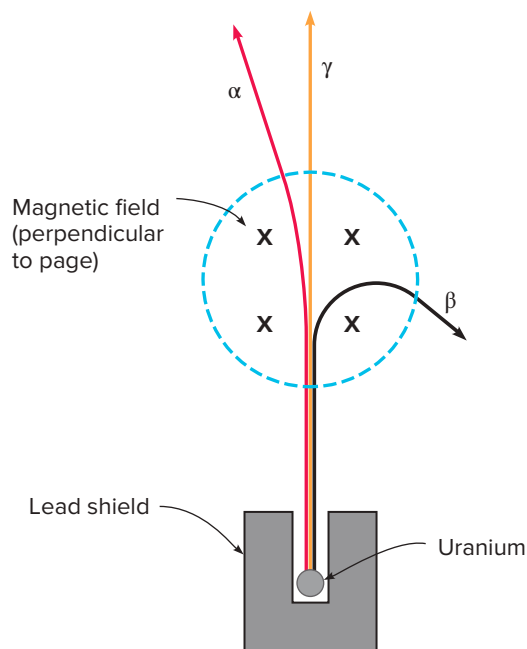
### Is more than one type of radiation involved in radioactivity?

Along with the discovery of X-rays, the discovery of natural radioactivity generated much new experimental activity and theoretical speculation. Many scientists were involved, most notably Marie (1867–1935) and Pierre (1859–1906) Curie and a young New Zealand-born physicist, Ernest Rutherford (1871–1937). The Curies, by painstaking chemical techniques, were able to isolate two more radioactive elements: radium and polonium. Both were contained in samples of uranium and thorium but were much more radioactive than uranium and thorium themselves.

Rutherford became interested in the nature of the radiation. One of his earliest experiments with this new phenomenon showed that at least three kinds of radiation came from the uranium samples. By placing a uranium sample at the base of a hole drilled in a piece of lead, he could produce a beam of radiation. When this beam was passed through a magnetic field produced by a strong magnet, it split into three components, as in figure 18.13.

Rutherford used the first three letters of the Greek alphabet— $\alpha$  (alpha),  $\beta$  (beta), and  $\gamma$  (gamma)—to name these three components. One of the components, alpha, deviated slightly to the left (fig. 18.13). Using the right-hand rule for the magnetic force, this is the direction we obtain for radiation consisting of positively charged particles. The location of the beam could be detected with photographic film or, more conveniently, with a zinc-sulfide screen, which produces flashes of light when struck by the beam.

The second component of the beam, beta, was bent in the opposite direction (as would be expected for negatively



**Figure 18.13** When the beam of radiation coming from a uranium sample passes through a magnetic field, it splits into three components, which are named  $\alpha$  (alpha),  $\beta$  (beta), and  $\gamma$  (gamma).

charged particles) and much more strongly than the alpha rays. Further study indicated that these beta rays were electrons, recently discovered by J. J. Thomson. The gamma rays, the third component, were undeviated by the magnetic field. These rays turned out to be a variety of electromagnetic waves similar to X-rays but with even shorter wavelengths.

Exactly what the alpha rays were remained a mystery, however, until clarified by an experiment performed by Rutherford and a student assistant, T. D. Roys. That these rays or particles were deviated only slightly by the magnetic field suggested that they were much more massive than the electrons in the beta portion of the beam. They were also the primary component emitted by the radium isolated by Marie and Pierre Curie.

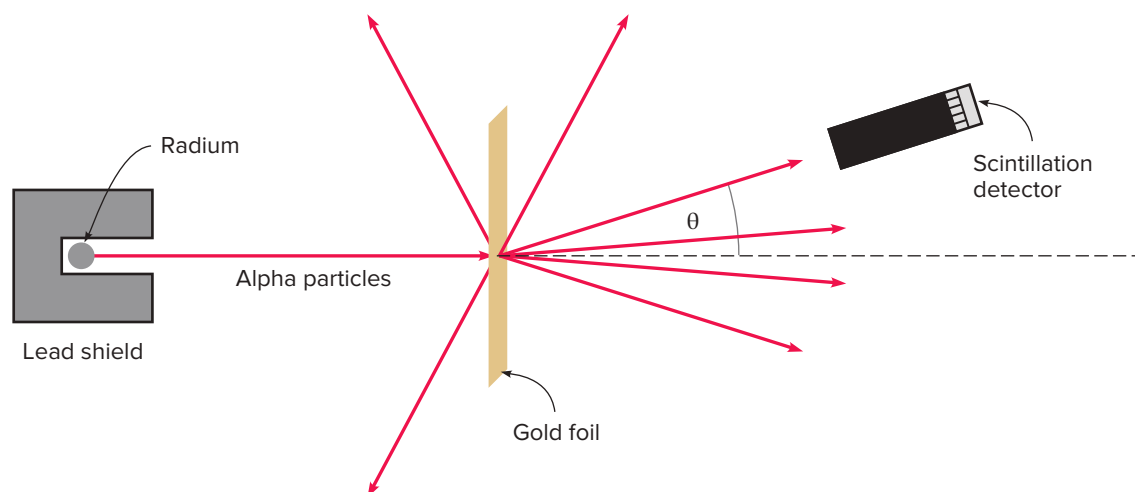
In 1908, Rutherford and Roys established that the alpha rays were helium atoms stripped of their electrons. They determined this by placing a small sample of radium in a very thin-walled tube sealed inside a somewhat larger tube. The alpha particles could escape from the thin-walled tube but not from the larger tube. The larger tube contained electrodes across which a high voltage was introduced to produce a glow discharge in the alpha-particle gas that accumulated. The colors of this discharge were characteristic of helium, which had not been present initially in the tube. (See section 18.4 for a discussion of atomic spectra.)

### How was the nucleus of the atom discovered?

Rutherford quickly realized that alpha particles would make effective probes for studying the structure of the atom. Because they were much more massive than electrons, and highly energetic, it seemed possible to get alpha particles inside the atom. By firing a beam of alpha particles at a thin metal foil and noting what happens to the beam, Rutherford thought he might deduce features of atomic structure. Such an experiment is called a *scattering* experiment.

The basic scheme of Rutherford's scattering experiments is illustrated in figure 18.14. An alpha-emitting substance, such as radium or polonium, is placed at the bottom of a hole in a lead shield to produce a beam of alpha particles. This beam is directed at a very thin foil of gold or other metal. The scattering of the alpha particles is then detected by a small, handheld scope with a zinc-sulfide screen at one end and a magnifying eyepiece at the other. The experimenter counts the flashes of light (scintillations) produced by alpha particles striking the screen at various angles from the initial direction of the beam.

The initial results of these experiments were not surprising or informative. Most of the alpha particles went straight through the gold foil without deviating much. A few were scattered through larger angles, but the number fell off rapidly as the angle from the initial direction of the beam was increased. These results seemed consistent with the prevailing view of the atom at that time: The mass and positive charge of the atom were seen as being distributed uniformly throughout the volume of the atom. Electrons, known to be present in atoms, were thought to be strewn here and there within this volume, much like the raisins in a plum pudding



**Figure 18.14** A beam of alpha particles was scattered from a thin gold foil in the experiments performed by Rutherford's assistants.

(a British dish). Such an arrangement would not be dense enough to affect a beam of energetic alpha particles.

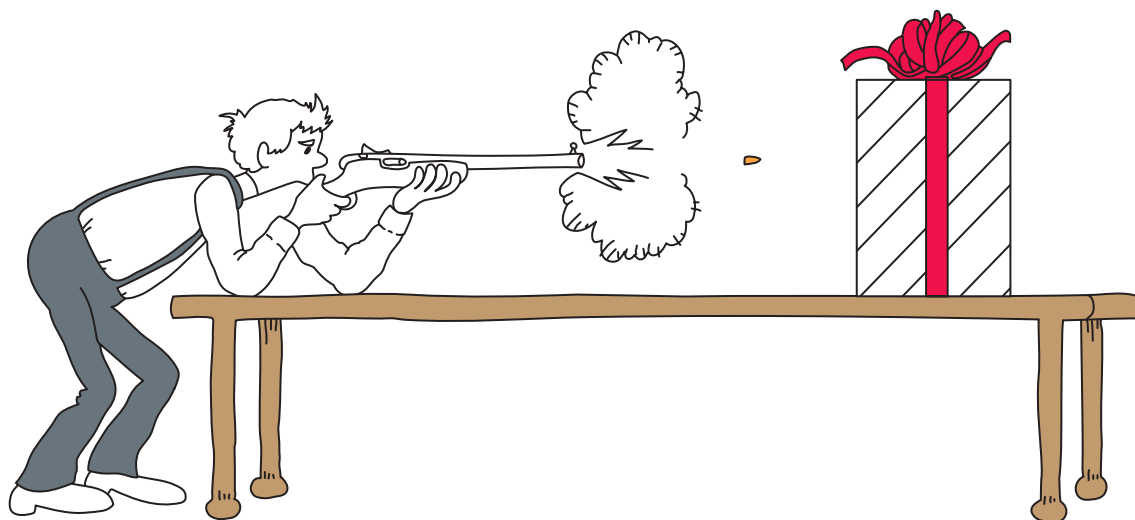
Just to be sure, however, Rutherford suggested to one of his students, an undergraduate named Ernest Marsden, that he look for scattered alpha particles reflected back from the foil. After a few days in the dark lab, squinting at occasional flashes of light through the detecting scope, Marsden reported to Rutherford that a few alpha particles did indeed scatter at these much larger angles. Rutherford was tempted not to believe him, but further checking by Marsden and a more senior research associate, Hans Geiger (1882–1947), verified their presence.

Much later, Rutherford said that the backward scattering was as if someone had fired bullets into a piece of tissue paper and the bullets bounced back. The result was totally unexpected. An analogy often used to explain this scattering experiment is illustrated in figure 18.15. Let's say we are trying to learn what is inside a Christmas present without opening the box. We may lift and shake the package to get

some sense of its weight and nature. Another (somewhat more destructive) test could be made by firing a rifle at the package and noting what happens to the bullets as they emerge (fig. 18.15). This is a scattering experiment similar to what Rutherford and his assistants performed.

If we had already determined that the package is not heavy, we would be surprised to find some of the bullets, even just a few, coming back toward us. Somewhere in the package, small but dense objects with enough mass to reverse the momentum of a rapidly moving bullet must be present. Because the package is not heavy and many of the bullets go right through, the objects responsible for the large-angle scattering must be small. Small steel balls held in a light but rigid packing material might do the job.

Similar reasoning applies to the atom. If most of the alpha particles go through, but a few are scattered through large angles, there must be very dense but small centers somewhere within the atoms massive enough to reverse the



**Figure 18.15** The contents of a Christmas present could be probed by firing a rifle into it and noting how the bullets are scattered by the contents.



momentum of rapidly moving alpha particles. To explain the quantitative results of the scattering experiment, Rutherford had to assume that these massive centers were very small indeed. By this time, atoms were known to have a diameter of approximately  $10^{-10}$  m. The diameter of the tiny but massive centers had to be just a ten-thousandth of the diameter of the atom in order to explain the data!

The discovery of the **nucleus** of the atom followed from the analysis of these scattering experiments. The nucleus was presumed to be a very dense center of the atom that contained most of the mass of the atom and all of its positive charge. (Because electrons are negatively charged, and the atom itself is electrically neutral, the nucleus had to be positively charged. This was consistent with the scattering results, where positively charged alpha particles were repelled by the nucleus.) The rest of the atom consisted of the electrons arranged somehow around this center. The electrons were responsible for most of the size of the atom, but for very little of its mass. To get a sense of the scale, imagine the atom enlarged to the size of a football field (about 100 m, counting the end zones). The nucleus would be roughly the size of a pea on the 50-yard line.

Rutherford's analysis of the alpha-particle scattering experiments performed by Geiger and Marsden was published in 1911. The idea that the atom has a tiny nucleus containing most of its mass and all of its positive charge presented a radical new view of the atom.

Becquerel discovered that a penetrating radiation, which he called natural radioactivity, was emitted by phosphorescent materials containing uranium or thorium. Rutherford showed that this radiation had three components: alpha (helium ions), beta (electrons), and gamma (short-wavelength X-rays). Using the alpha particles as probes in scattering experiments, Rutherford and his assistants realized that the atom must have a tiny, massive, positive center, which we now call the nucleus. This set the stage for the first successful model of the atom.

## 18.4 Atomic Spectra and the Bohr Model of the Atom

If the atom has a positively charged nucleus, and electrons (with their negative charges) are arranged somehow around this nucleus, it is natural to compare the atom to the solar system. In the solar system, the planets are held in orbit about the sun by the gravitational force, which is proportional to the inverse square of the distance ( $1/r^2$ ) between the planets and the sun (see chapter 5). In an atom, the electrons are attracted to the nucleus by the electrostatic force, which by Coulomb's law is also proportional to the inverse square of the distance. Maybe an atom is like a miniature solar system.

Although the comparison was intriguing, there were some problems. Because an orbiting electron should act like a transmitting antenna and radiate electromagnetic waves, the atom would lose energy, and the electron would spiral

into the nucleus, causing the atom to collapse. Physicists were aware, though, that atoms did sometimes emit electromagnetic waves in the form of light. The patterns of the light emitted by the smallest atom, hydrogen, were particularly interesting because of their simplicity.

Niels Bohr (1885–1962) was working with Rutherford when the nucleus was discovered. Bohr's model of the atom first suggested answers to these problems and provided an explanation of the wavelengths of light (the *spectrum*) emitted by hydrogen. The publication of Bohr's model of the atom in 1913 opened a tremendously exciting period of research, which resulted in our current understanding of atomic structure.

### What is the nature of the hydrogen spectrum?

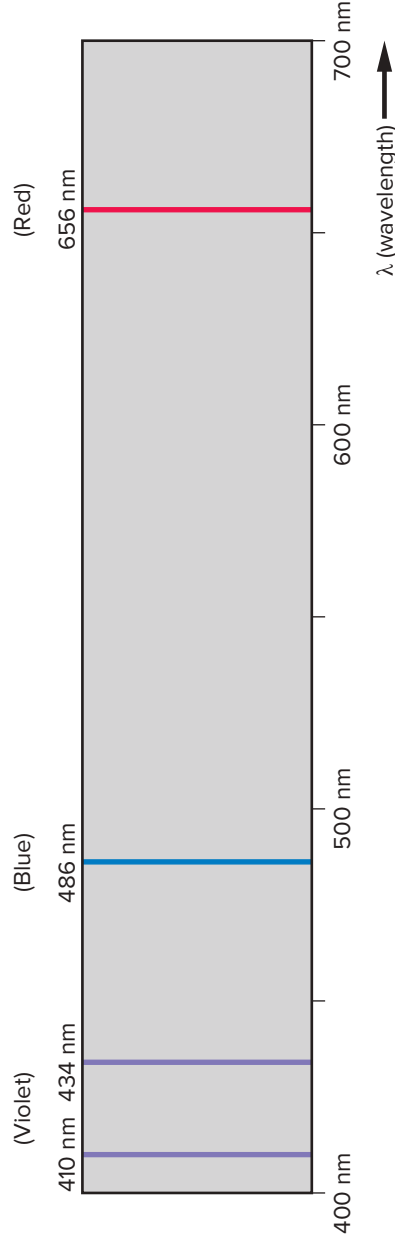
The study of the light emitted by different substances began more than 50 years before Bohr's work. If a substance is heated in the flame of a Bunsen burner and the emitted light observed through a prism, each substance produces characteristic colors or wavelengths. These characteristic wavelengths are the **atomic spectrum** of that substance.

For gases, the most convenient way of producing this spectrum was in a gas-discharge tube. (We encountered this phenomenon in section 18.2 when we discussed cathode rays.) When a high voltage is placed across electrodes sealed inside a tube containing a gas at low pressure, a colorful discharge is observed (fig. 18.16). This is what happens in a



**Figure 18.16** A high voltage placed across the electrodes of a gas-discharge tube produces a colorful glow. The colors are characteristic of the type of gas in the tube.

Richard Megna/Fundamental Photographs, NYC



**Figure 18.17** The hydrogen gas–discharge spectrum has four lines in its visible portion: a red line, a blue line, and two violet lines.

fluorescent light, too, although the light tube has a fluorescent coating to produce a more uniform distribution of wavelengths.

If you observe the light emitted by a gas discharge through a prism or diffraction grating, you see that the spectrum consists of a series of discrete, bright lines at specific wavelengths. (As discussed in section 16.4, diffraction gratings use interference effects to separate wavelengths.) If the source itself is long and thin (fig. 18.16) or if the light passes through an entrance slit, the separate wavelengths show up as colored lines. Each kind of gas has its own spectrum, which can be used as a reliable means of identifying the substance.

The spectrum of hydrogen is quite simple. The visible portion (fig. 18.17) has just four wavelengths—a red line, a blue line, and two violet lines. The 410-nm violet line is harder to see, mostly because the eye is less sensitive at that wavelength (see fig. 16.8). In 1884, a Swiss teacher, J. J. Balmer (1825–1898), discovered that the wavelengths of these four lines could all be computed from a simple formula. Balmer’s formula is not based on underlying theory but is just a numerical way to compute the wavelengths of the observed lines. When other lines were discovered in the near-ultraviolet portion of the spectrum, they also were correctly described by Balmer’s formula.

Somewhat later, other series of spectral lines were discovered for hydrogen in the infrared and ultraviolet regions. All of these lines could be predicted from a generalized form of Balmer’s formula published in 1908 by Rydberg and Ritz. This formula is usually written as

$$\frac{1}{\lambda} = R \left( \frac{1}{n^2} - \frac{1}{m^2} \right)$$

where  $n$  and  $m$  are both integers and  $R$  is called the **Rydberg constant**,  $R = 1.097 \times 10^7 \text{ m}^{-1}$ .

Setting  $n = 2$ , we get the Balmer series of lines lying in the visible and near ultraviolet. For  $n = 1$ , we get a series in the ultraviolet portion of the spectrum, which has

wavelengths shorter than visible wavelengths. For  $n = 3$  or 4, we get lines in the infrared region (see example box 18.2), with wavelengths longer than visible wavelengths. The integer  $m$  is always greater than  $n$  for a given series. For the Balmer series,  $n = 2$ , and  $m$  can be 3, 4, 5, and so on. Each value of the integer  $m$  generates a different line in the series.

### Example Box 18.2

#### Sample Exercise: Using the Rydberg Formula

What is the wavelength of the photon in the infrared series of the hydrogen spectrum for  $m = 6$  and  $n = 3$ ? Use the Rydberg formula.

$$R = 1.097 \times 10^7 \text{ m}^{-1}$$

$$m = 6$$

$$n = 3$$

$$\lambda = ?$$

$$\frac{1}{\lambda} = R \left( \frac{1}{n^2} - \frac{1}{m^2} \right)$$

$$= 1.097 \times 10^7 \text{ m}^{-1} \left( \frac{1}{3^2} - \frac{1}{6^2} \right)$$

$$= 1.097 \times 10^7 \text{ m}^{-1} \left( \frac{1}{9} - \frac{1}{36} \right)$$

$$= 1.097 \times 10^7 \text{ m}^{-1} (0.0833)$$

$$\frac{1}{\lambda} = 9.14 \times 10^5 \text{ m}^{-1}$$

$$\lambda = \frac{1}{9.14 \times 10^5 \text{ m}^{-1}} = \mathbf{10.94 \times 10^{-7} \text{ m}}$$

Notice that this result is in the infrared region of the electromagnetic spectrum, because its wavelength is greater than  $7.5 \times 10^{-7} \text{ m}$ , as discussed in chapter 16. Notice also that the  $m$  appearing in the Rydberg formula is an integer and has nothing to do with the unit  $\text{m}^{-1}$ , which is an inverse meter.

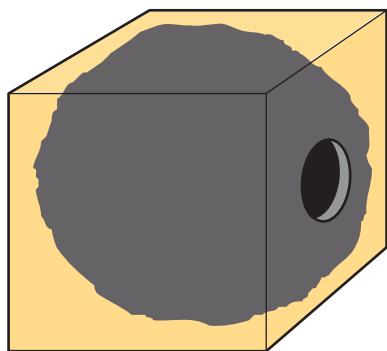
The formula developed by Rydberg and Ritz pointed out a simple regularity in the spectrum of hydrogen that cried out for explanation. Thomson, in creating his so-called plum-pudding model of the atom, had attempted to explain this regularity without success. Bohr, working with the new view of the atom provided by Rutherford, took a fresh approach to the problem.

### Quantization of light energy

Although the discovery of the nucleus and the regularities in the spectrum of hydrogen were crucial to Bohr's model, another new idea was at least as important. Introduced tentatively by Max Planck (1858–1947) in 1900 and later strengthened by Albert Einstein (1879–1955), it also had its origin in the study of spectra, in this case the spectrum produced by a heated **blackbody**.

A blackbody is best represented by a hole or cavity carved into metal or ceramic material that can be heated to high temperatures (fig. 18.18). Such a hole appears black at room temperature. The spectrum it emits when heated depends only on the temperature and not on the material in which the cavity is carved. The spectrum is continuous (no discrete lines), but the average wavelength emitted becomes shorter as the temperature is increased. At high temperatures, the wavelengths become short enough to be visible: The cavity first appears “red hot,” and at even higher temperatures “white hot,” meaning that the average wavelength is near the middle of the visible spectrum.

Planck and other theorists were trying to explain the distribution of wavelengths that emerged from a heated blackbody. Planck arrived at a formula that succeeded in predicting the proper distribution and its dependence on temperature. In giving a rationale for his formula, however, he was forced to a radical conclusion: Apparently, light could not be absorbed or emitted from the surface of the blackbody in continuously varying energies but only in discrete chunks, or *quanta*, whose energy depended on the frequency or wavelength.



**Figure 18.18** A blackbody radiator consists of a hole carved in material that can be heated to high temperatures. When heated, it emits a continuous spectrum of electromagnetic radiation.

To be more precise, at a given frequency, the only energies allowed are integer multiples of the energy:

$$E = hf$$

where  $f$  is the frequency and  $h$  is a constant called **Planck's constant**. The value of this constant is extremely small. In metric units, it is

$$h = 6.626 \times 10^{-34} \text{ J}\cdot\text{s}$$

According to Planck's theory, for a particular frequency  $f$ , light can be emitted with energies of  $hf$ ,  $2hf$ ,  $3hf$ , and so on, but not at any energy between these values.

This idea disturbed Planck, as well as other physicists of that time. There had previously been no reason to suspect that light waves could not be emitted in continuously varying energies, depending only on how much energy was available. The idea that this process was **quantized**, meaning that it could only happen in discrete energy chunks, was indeed radical. In 1905, Einstein showed that the quantization of light energy could be used to explain a number of other phenomena. The idea of light quanta (or particles of light that we now call **photons**) having energies  $E = hf$  was thus available, if not fully accepted, when Bohr began to develop a new model of the atom.

### What were the features of Bohr's model?

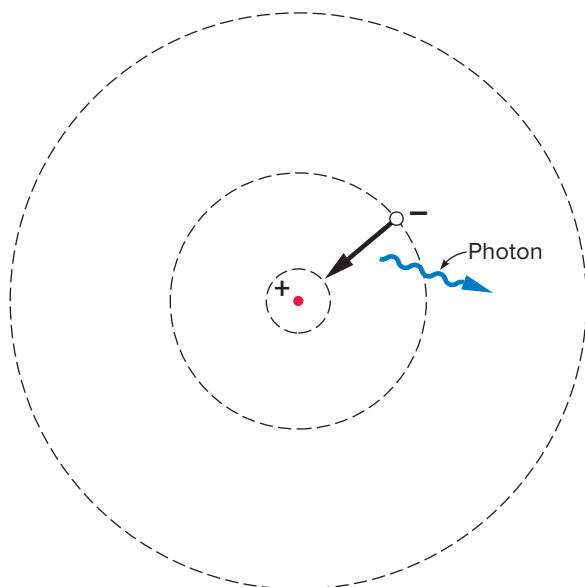
Bohr's accomplishment was to combine all of these ideas—the discovery of the nucleus, knowledge of the electron, the regularities in the hydrogen spectrum, and the new quantum ideas of Planck and Einstein—into a new model of the atom. He started with the miniature-solar-system model mentioned at the beginning of this section, in which the electron in the hydrogen atom orbits about the nucleus. The electrostatic force provides the necessary centripetal acceleration.

Bohr's first bold step departed from classical physics: He assumed certain stable orbits that do not continuously radiate electromagnetic waves as expected from classical physics. Instead, he imagined that light is emitted from the atom when the electron jumps from one stable orbit to another (fig. 18.19). Because the energy of a quantum of light, or photon, as given by Planck and Einstein, is  $E = hf$ , the energy of the emitted photon is equal to the difference in energies of the two stable (or almost-stable) orbits—expressed in symbols,

$$E = hf = E_{\text{initial}} - E_{\text{final}}$$

where  $E_{\text{initial}}$  is the energy of the electron in the initial orbit, and  $E_{\text{final}}$  is the energy of the electron in the final orbit. These energies could be calculated for a specific orbital radius with ordinary Newtonian mechanics.

This energy difference could then be used to compute the frequency or wavelength of the emitted photon. Comparison of the resulting formula to the Rydberg-Ritz formula for the lines in the hydrogen spectrum showed that the energies of the stable orbits must all be given by a constant divided by



**Figure 18.19** Bohr pictured the electron as orbiting the nucleus in certain quasi-stable orbits. Light is emitted when the electron jumps from one orbit to another.

an integer squared,  $E = E_0/n^2$ . This relationship placed a condition on the orbits: The only orbits allowed were those whose angular momentum,  $L$ , was equal to

$$L = n \left( \frac{h}{2\pi} \right)$$

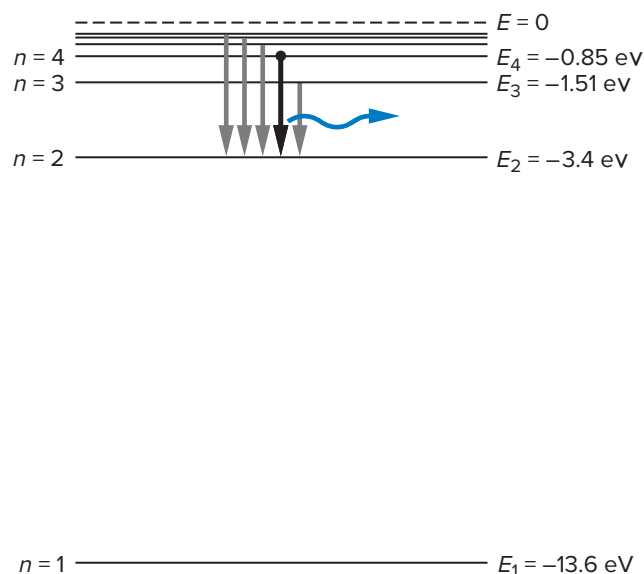
where  $n$  is an integer and  $h$  is Planck's constant.

These are the essential features of Bohr's model:

1. Electrons are pictured as orbiting the nucleus in certain quasi-stable orbits, given by the condition  $L = n(h/2\pi)$ .
2. Light is emitted when an electron jumps from a higher-energy orbit to a lower-energy orbit.
3. The frequencies and wavelengths of the emitted light are computed from the energy differences between the two orbits, yielding the wavelengths in the hydrogen spectrum.

Figure 18.20 shows an energy-level diagram computed from Bohr's model for hydrogen. Example box 18.3 uses these values to find the wavelength of one line in the Balmer series of the hydrogen spectrum. The energy values in the diagram and exercise are expressed in *electron volts* rather than joules. An electron volt (eV) is the amount of kinetic energy gained when an electron is accelerated through a potential difference of 1 volt. It has the value  $1 \text{ eV} = 1.6 \times 10^{-19} \text{ J}$ . The energy levels in figure 18.20 can all be found by dividing the bottom level ( $-13.6 \text{ eV}$ ) by  $n^2$ , as predicted by the Bohr model. The energy values are all negative and go to zero as the  $n$  values get larger.

One of the most striking successes of Bohr's model was that it could predict the correct value of the Rydberg constant from quantities such as the mass of the electron, the charge of



**Figure 18.20** The energies for the different orbits are shown in an energy-level diagram for hydrogen. The Balmer lines are produced by the indicated transitions. The transition for the blue line is highlighted.

the electron, Planck's constant, and the speed of light. Bohr's theory was an instant and controversial sensation in the physics community. Its introduction spurred intense activity in both experimental and theoretical physics. Much of the experimental work focused on making more accurate measurements of the atomic spectra of different elements. The theoretical work sought to extend Bohr's model to atoms other than hydrogen and to try to understand the periodic properties observed in the periodic table of the elements.

Despite its impressive successes, the Bohr model left many unanswered questions. The most bothersome question was why just those few orbits described by the Bohr condition should be stable and not others. Attempts to extend the Bohr model to elements other than hydrogen met with limited success. Physicists now recognize that the Bohr model is inaccurate in many of its details. Its historic significance was that it opened the door to research that ultimately led to our modern theory of the atom.

The atomic spectrum of hydrogen has a particularly simple and regular form; the measured wavelengths are accurately described by the Rydberg formula. Bohr used these results, together with Rutherford's discovery of the nucleus and the Planck-Einstein condition for quantization of light energy, to develop a model of the hydrogen atom. Bohr assumed that there were just a few stable orbits for the electron about the nucleus. Light was emitted when the electron jumped from a higher-energy orbit to a lower-energy orbit. His model accurately described the wavelengths in the hydrogen spectrum and predicted the value of the Rydberg constant from fundamental quantities.

### Example Box 18.3

#### Sample Exercise: Energy Levels in a Hydrogen Atom

Using the energy values shown in figure 18.20, calculate the wavelength of the photon emitted in the transition from the  $n = 4$  energy level to the  $n = 2$  energy level in the Bohr model of the hydrogen atom.

$$\begin{array}{ll} E_2 = -3.4 \text{ eV} & \text{The energy difference is} \\ E_4 = -0.85 \text{ eV} & \Delta E = E_4 - E_2 \\ \lambda = ? & = -0.85 \text{ eV} - (-3.4 \text{ eV}) \\ & = 2.55 \text{ eV} \end{array}$$

Using  $h = 6.626 \times 10^{-34} \text{ J}\cdot\text{s} = 4.14 \times 10^{-15} \text{ eV}\cdot\text{s}$ , the frequency of the emitted photon is given by

$$\begin{aligned} E &= hf \\ f &= \frac{E}{h} \\ &= \frac{2.55 \text{ eV}}{4.14 \times 10^{-15} \text{ eV}\cdot\text{s}} \\ &= 6.16 \times 10^{14} \text{ Hz} \end{aligned}$$

From  $v = c = f\lambda$ , the wavelength of the emitted photon is then

$$\begin{aligned} \lambda &= \frac{c}{f} \\ &= \frac{3 \times 10^8 \text{ m/s}}{6.16 \times 10^{14} \text{ Hz}} \\ &= 4.87 \times 10^{-7} \text{ m} = \mathbf{487 \text{ nm}} \end{aligned}$$

This is the blue line in the Balmer series of the hydrogen spectrum, pictured in figure 18.17.

## 18.5 Particle Waves and Quantum Mechanics

The unanswered questions and the intense activity generated by Bohr's model of the atom attracted many young physicists to the field of atomic physics. A more comprehensive model of the atom that could explain why only certain orbits were stable obviously was needed. That need was filled when quantum mechanics was developed in 1925. Quantum mechanics was actually developed from two independent approaches, which were quickly shown to be fundamentally the same in their structure and predictions.

The approach that is usually described followed from the work of Louis de Broglie (1892–1987) and Erwin Schrödinger (1887–1961). De Broglie sparked the fire by asking a simple but radical question: If light waves sometimes behave as particles (as shown by Planck and Einstein),

could particles sometimes behave as waves? That question produced a revolution in our thinking about basic physical principles.

### What are de Broglie waves?

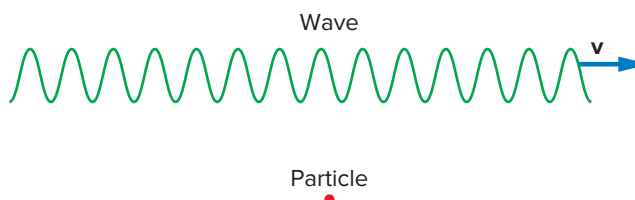
The question posed by de Broglie was inspired by the concept of the photon introduced by Planck and Einstein. In 1865, Maxwell had shown that light could be described as an electromagnetic wave. On the other hand, light sometimes behaved as though it were made up of discrete and localized, particle-like bundles of energy, now called photons. Certain experiments involving the interaction of light with electrons were most simply explained by thinking of light as a particle.

Einstein was the leader in pointing out this aspect of light. His 1905 paper discussed a number of phenomena that could be treated this way, the simplest being the photoelectric effect, a phenomenon in which light shining on an electrode in an evacuated tube causes an electric current to flow across the tube. This effect is frequently used in electric-eye devices that open doors when a person interrupts the light beam.

Einstein showed that the photoelectric effect could be explained by assuming that one photon of light, with energy  $E = hf$ , as suggested by Planck's work, ejected one electron on hitting the electrode. This simple model predicted the observed frequency dependence of the photoelectric effect as well as its other features. Other effects could also be treated in this manner by attributing an energy,  $E = hf$ , and a momentum,  $p = h/\lambda$ , to the photon.

Although this idea was simple, physicists were slow to accept it, because particles and waves were thought to be very different phenomena. It was hard to understand how light could behave as a particle in some respects and a wave in others. An ideal wave extends indefinitely in space, but an ideal particle is a completely localized, simple point in space (fig. 18.21). *Real* waves have a finite length, of course, and *real* particles have some extension in space, but the concepts are still quite different.

De Broglie suggested that certain things traditionally thought of as particles, such as the electron, might sometimes behave as waves. In particular, he proposed that we reverse the relationships that described the energy and



**Figure 18.21** An ideal wave goes on indefinitely, but an ideal particle is just a point with no volume or extension in space.

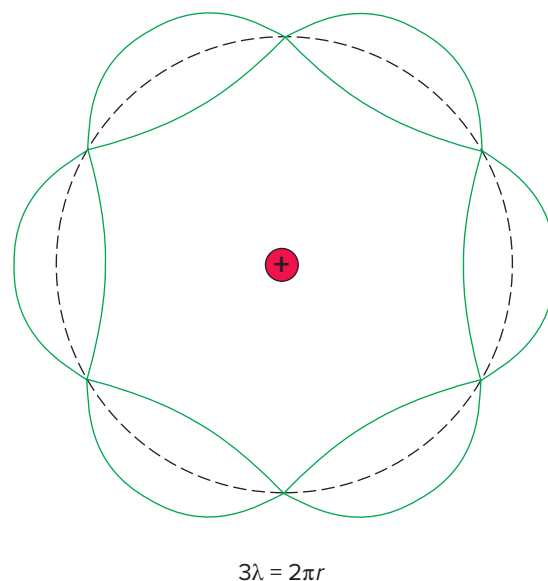
momentum of a photon to find the frequency and wavelength associated with a particle. Inverting the energy relationship yields a frequency for the particle of  $f = E/h$ . Photons have a momentum  $p = h/\lambda$ , and inverting this relationship yields the *de Broglie wavelength*

$$\lambda = \frac{h}{p}$$

where  $p$  is the momentum and  $h$  is Planck's constant. In example box 18.4, we compute the extremely small de Broglie wavelength of a baseball. Given the energy and momentum of an electron, we could compute its frequency and wavelength from these relationships.

De Broglie's suggestion might have passed unnoticed if not for a striking result that he obtained. If he treated the electron as a wavelike entity orbiting the nucleus of the hydrogen atom, he could explain the condition for the quasi-stable orbits in Bohr's atomic model. He pictured the electron wave forming a standing wave wound around the circular orbit, as in figure 18.22.

To form a circular standing wave, the wavelength would have to be restricted to values such that an integer number of wavelengths would fit onto the circumference of the circle. By using the de Broglie wavelength for the electron, de Broglie could derive the Bohr condition on the allowed values of angular momentum,  $L = n(h/2\pi)$ . In other words, by assuming that particles had wavelike properties and by visualizing a standing-particle wave winding around a circular orbit, de Broglie could



**Figure 18.22** If the electron were pictured as a standing wave wrapped around a circular orbit, de Broglie showed that its wavelength could take on only certain values. These values yield the quasi-stable orbits predicted by Bohr.

explain why only certain orbits would be stable. He had answered one of the fundamental questions in Bohr's theory.

De Broglie's picture of a standing wave on a circular orbit should not be taken literally. In fact, both the Bohr model and the standing-wave explanation predict the wrong value for the angular momentum of the various stable states in the hydrogen atom. The basic difficulty is that a circular orbit is two-dimensional and the atom itself is three-dimensional. We need a more sophisticated analysis to depict the standing waves properly.

The suggestion that particles had wavelike properties was quickly borne out by experiment. It was known that X-rays, which are electromagnetic waves, could be diffracted by a crystal lattice to form interference patterns characteristic of the crystal structure. Various workers soon showed that electron beams could also be diffracted. The interference patterns that resulted looked just like those obtained with X-rays for the same crystal, and the wavelengths needed to explain these patterns were exactly the ones predicted by de Broglie's relationship,  $\lambda = h/p$ .

### How does quantum mechanics differ from the Bohr model?

Erwin Schrödinger had spent much of his professional life studying the mathematics of standing waves in two and three dimensions. He was well prepared to explore the implications of standing electron waves in the atom. In the year following de Broglie's suggestion, Schrödinger developed a theory of the atom that used three-dimensional standing waves to describe the orbits of the electron about the nucleus.

## Example Box 18.4

### Sample Exercise: Finding the Wavelength of a Baseball

What is the de Broglie wavelength, in meters, of a 145-g baseball traveling at 80 mph?

$$m = 145 \text{ g} = 0.145 \text{ kg} \quad p = mv$$

$$v = 80 \text{ mph} = 35.7 \text{ m/s}$$

$$h = 6.626 \times 10^{-34} \text{ Js} \quad \lambda = \frac{h}{p}$$

$$\lambda = ?$$

$$\lambda = \frac{h}{mv}$$

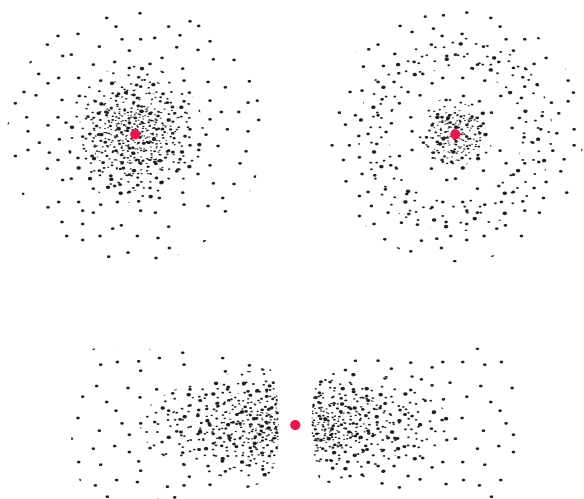
$$\lambda = \frac{6.626 \times 10^{-34} \text{ Js}}{(0.145 \text{ kg})(35.7 \text{ m/s})}$$

$$\lambda = \frac{6.626 \times 10^{-34} \text{ Nms}}{5.17 \text{ kgm/s}}$$

$$\lambda = \frac{6.626 \times 10^{-34} \text{ Nms}}{5.17 \text{ Ns}}$$

$$\lambda = 1.28 \times 10^{-34} \text{ m}$$

Notice how small this wavelength is! It makes it impossible to detect wavelike properties of everyday objects, even with sophisticated technology.



**Figure 18.23** The probability of finding the electron at different distances from the nucleus is given by these probability density diagrams of the ground state (top left) and two excited states of the hydrogen atom.

Within the next five years, Schrödinger and other scientists pursuing the same problem from different approaches worked out the details of the theory we now call **quantum mechanics**. This new theory gave a much more complete and satisfactory view of the hydrogen atom than the Bohr model. Quantum mechanics predicted the same primary energy levels for the hydrogen atom as the Bohr model, though we now know several other features of the Bohr model are incorrect.

In quantum mechanics, the orbits are not simple curves, as pictured in the Bohr model. Instead, they are three-dimensional probability distributions centered on the nucleus. These distributions rely on treating the electron as a standing wave. These standing waves describe the probability of finding electrons at certain distances and orientations about the nucleus. The probability distributions of the ground state and two excited states of the hydrogen atom appear in figure 18.23. The dark or denser areas are the places where the electron is most likely to be found. The average distances of the electron from the nucleus for different quasi-stable orbits are consistent with the orbital radii given by the Bohr model.

### What is the Heisenberg uncertainty principle?

Dealing with probability distributions rather than well-defined orbital paths is a fundamental, necessary feature of quantum mechanics. The waves associated with electrons and other particles predict a probability for finding the electron at various positions, but they cannot tell us exactly where the particle is located. Likewise, electromagnetic waves give us a probability of finding photons

at various positions. In situations where wave properties are dominant, we lose information about precise particle locations.

This limitation on what we can know about a particle's location is summarized in the famous **Heisenberg uncertainty principle**, introduced by Werner Heisenberg (1901–1976). This principle states that the position and momentum of a particle cannot both be known simultaneously with high precision. There will be an uncertainty in one that depends on how precisely we have determined the other. In symbols, this limitation takes the form

$$\Delta p \Delta x \geq \frac{h}{2\pi}$$

where  $h$  is Planck's constant,  $\Delta p$  is the uncertainty in the momentum of the particle, and  $\Delta x$  is the uncertainty in its position. If the uncertainty in position is small, the uncertainty in momentum must be large, and vice versa.

Because the momentum  $p$  is related to the wavelength associated with the particle by the de Broglie relationship  $\lambda = h/p$ , the uncertainty principle says that if we know the wavelength accurately, we cannot know the position of the particle accurately. The converse is also true: If we know the position accurately, we cannot know the wavelength accurately. Some experiments tend to bring out the particle-like aspects of photons or electrons (knowledge of position), and others tend to bring out the wave features (knowledge of wavelength).

Heisenberg's uncertainty principle is a fundamental limitation on what we can observe, rather than a lack of experimental capability. The limitation is an inevitable feature of wave pulses. If we attempt to localize a wave by creating a brief pulse, the wavelength cannot be accurately defined. On the other hand, an extended wave, which permits accurate definition of the wavelength, gives us no precise information regarding position.

### How does quantum mechanics explain the periodic table?

Quantum mechanics provides a means of answering most of the questions raised by the Bohr model about atomic structure and spectra. In particular, quantum mechanics is successful in predicting the structure and spectra of atoms with many electrons, although the computations are difficult. It also clarifies other features of the spectra that cannot be understood using the Bohr model.

The picture of atomic structure that emerges from quantum mechanics had already been partially assembled from attempts to explain the regularities in the periodic table of the elements. The theory provides us with **quantum numbers** that describe the various possible stable orbits. One of these is the *principal quantum number*,  $n$ , needed to compute the energies in the Bohr model. Quantum mechanics provides three others, however, associated with the

magnitude and orientation of the angular momentum and with the spin of the electron. (Experimental evidence indicated that the electron behaves as a magnetic dipole, suggesting that it must be spinning to form a tiny current loop.)

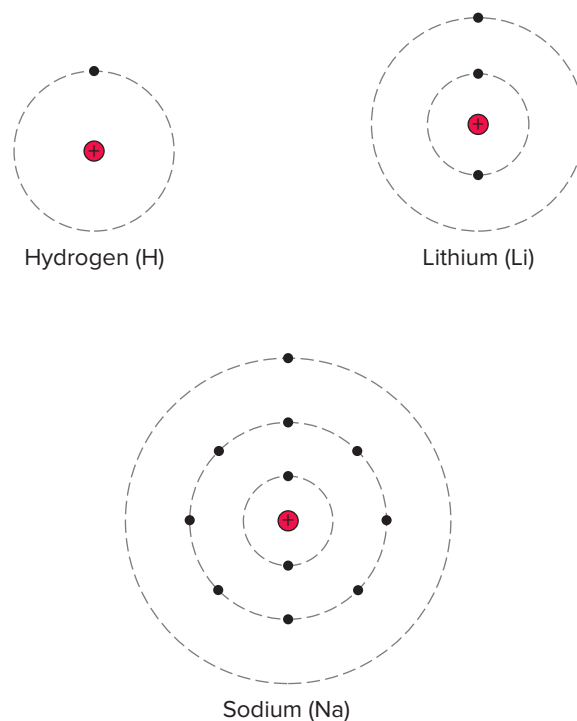
No two electrons in an atom can have the same set of quantum numbers. Once an orbit is filled, other electrons must take on new, and generally higher, values for at least one of the quantum numbers. The number of possible combinations increases rapidly as the principal quantum number  $n$  increases. For  $n = 1$ , there are only 2 possible combinations corresponding to two different orientations of the electron-spin axis, but for  $n = 2$ , there are 8; for  $n = 3$ , 18; and so on. Once the two possible states for  $n = 1$  are filled, the next electron added must go into an  $n = 2$  level, or *shell*.

From this conception, we can explain certain regularities of the periodic table. The first two elements, hydrogen (H) and helium (He), have 1 and 2 electrons, respectively. Two electrons fill the  $n = 1$  shell. The next element, lithium (Li), which has 3 electrons, must have its third electron in the  $n = 2$  shell. Because lithium has 1 electron beyond the filled  $n = 1$  shell, its chemical properties are quite similar to those of hydrogen, which has just 1 electron. Likewise, the next element in that column of the periodic table, sodium (Na), has 1 electron beyond the filled  $n = 2$  shell. Its other 10 electrons fill the  $n = 1$  and  $n = 2$  levels, 2 in the first shell and 8 in the second shell. Figure 18.24 shows a schematic representation of the shell structure of hydrogen, lithium, and sodium.

The element immediately preceding sodium in the periodic table is neon (Ne), which has 10 electrons: 2 in the  $n = 1$  shell and 8 in the  $n = 2$  shell. Like helium, therefore, it has a closed-shell arrangement and does not react readily with other elements. Helium and neon are both **noble gases**, which are chemically nonreactive.

Fluorine (F), however, has nine electrons, one short of a filled shell, and is very reactive. It forms compounds with elements such as hydrogen or sodium, which can contribute an electron to close a shell.

The principles used in explaining the entire periodic table are the same as those we have just outlined, although the details become more complicated with higher numbers of electrons. The theory explains the regularities of the periodic table and is highly successful in predicting the ways different elements combine to form chemical compounds. Quantum mechanics has become the fundamental theory of chemistry, as well as atomic, nuclear, and condensed-matter physics.



**Figure 18.24** The chemical properties of sodium, with one electron in the  $n = 3$  shell, are similar to those of hydrogen and lithium, which also have a single electron in their outermost shells.

Louis de Broglie suggested that particles such as electrons might have wavelike properties. Using this idea, he was able to explain the Bohr condition for stable orbits in the hydrogen atom. Thinking of particles as having wavelike properties leads directly to the Heisenberg uncertainty principle, which tells us that we cannot precisely determine both the position and the momentum of a particle at the same time. Quantum mechanics treats the standing waves associated with electrons in the atom as three-dimensional probability distributions. This theory has been successful in predicting the spectra and chemical properties of atoms with many electrons. Shells explain why we get the regularities described by the periodic table. Quantum mechanics is now the fundamental theory underlying most areas of physics and chemistry.

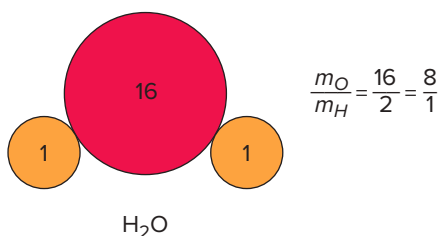


## Summary

In a period of less than 50 years, we progressed from knowing virtually nothing about the structure of the atom to having detailed knowledge of that structure. Some of the critical discoveries that led to this knowledge were discussed in this chapter, starting from chemical evidence for the existence of atoms and culminating in the theory called quantum mechanics, which explains atomic structure.

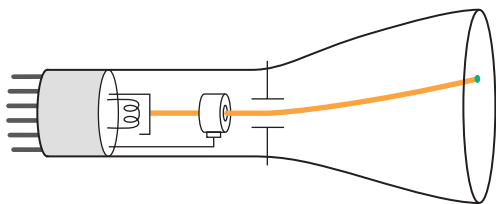
### 1 The existence of atoms: Evidence from chemistry.

Recognition of the importance of weighing chemical reactants and products led to the statement of the law of definite proportions and the concept of atomic mass. If each element consists of atoms, all having the same mass, we can explain the mass ratios observed in chemical reactions. The periodic table shows regularities in the properties of different elements when they are organized in order of increasing atomic weight.



### 2 Cathode rays, electrons, and X-rays.

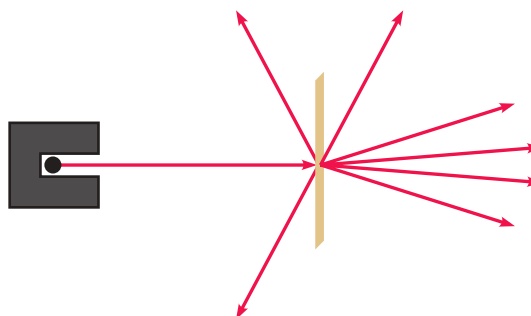
The study of cathode rays, produced by placing a high voltage across two electrodes in an evacuated tube, led to the discovery of the electron and X-rays. The electron is a negatively charged particle with a mass much smaller than that of the smallest atom, so it was the first known subatomic particle available for building atomic models.



### 3 Radioactivity and the discovery of the nucleus.

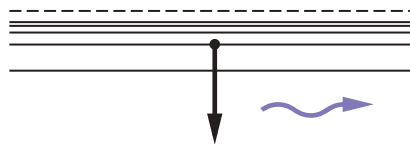
Natural radioactivity, discovered shortly after the discovery of X-rays, has three components: alpha (helium ions), beta (electrons),

and gamma (short-wavelength X-rays). The alpha rays were used to probe the structure of the atom in scattering experiments, which led to the discovery of the nucleus of the atom.



### 4 Atomic spectra and the Bohr model of the atom.

Bohr explained the regularities in the observed spectrum of hydrogen (the colors of light emitted by excited hydrogen atoms) with a model that incorporated the new quantum ideas introduced by Planck and Einstein. Bohr pictured light as being emitted when an electron jumped from one stable orbit to a lower-energy orbit. The energy difference explained the frequency and wavelength of the emitted photons.



$$\Delta E = hf = \frac{hc}{\lambda}$$

### 5 Particle waves and quantum mechanics.

De Broglie's suggestion that particles such as electrons could have wave-like properties characterized by a wavelength related to the momentum of the particle,  $\lambda = h/p$ , was one path that led to the development of quantum mechanics. The stable orbits of the electrons in atoms can be described in terms of three-dimensional standing waves in this theory. The resulting probability distributions can explain the atomic spectra and chemical properties of multi-electron atoms.

## Key Terms

Element, 384

Atom, 384

Combustion, 384

Dalton's law of definite proportions, 385

Molecule, 385

Atomic mass, 385

Periodic table of the elements, 388

Cathode rays, 389

Electron, 392

X-rays, 392

Natural radioactivity, 393

Nucleus, 396

Atomic spectrum, 396

Rydberg constant, 397

Blackbody, 398

Planck's constant, 398

Quantized, 398

Photon, 398

Quantum mechanics, 402

Heisenberg uncertainty principle, 402

Quantum number, 402

Noble gas, 403

## Conceptual Questions

\* = more open-ended questions, requiring lengthier responses, suitable for group discussion

**Q** = sample responses are available in appendix D

**Q** = sample responses are available in Connect

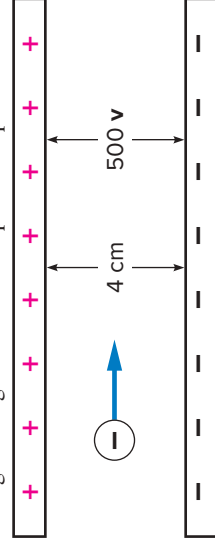
- Q1. Is a chemical element the same as a chemical compound? Explain.
- Q2. Can the element iron (Fe) be changed to gold (Au) by heating it to a high enough temperature? Explain.
- Q3.** When a substance is burned, are all of the products of that reaction solid substances that can be easily weighed? Explain.
- Q4. Can the hydrogen and oxygen needed in fuel cells be mined as free elements from the atmosphere or the Earth, or do they have to be extracted from compounds? Explain. (See everyday phenomenon box 18.1.)
- Q5. Do cars using hydrogen fuel cells have approximately the same range as cars using gasoline? Explain. (See everyday phenomenon box 18.1.)
- Q6.** Is mass conserved in a chemical reaction? Explain.
- Q7. In a chemical reaction, do the elements involved change into different elements as the reaction proceeds? Explain.
- Q8. Does an atom of carbon (C) have the same mass as one atom of oxygen (O)? Explain.
- Q9.** Is it possible for any number of hydrogen atoms to combine with just one atom of oxygen? Explain.
- \*Q10. Can the law of definite proportions be explained by a model in which different atoms of the same element have widely varying masses? Explain.
- Q11. Do cathode rays consist of electromagnetic waves? Explain.
- Q12.** Do X-rays consist of electromagnetic waves? Explain.
- Q13. Assuming that cathode rays are a beam of charged particles, how could you demonstrate that these particles are negatively charged? Explain.
- Q14. What characteristics of the negatively charged particles that make up cathode rays suggested to Thomson that they might be atomic building blocks? Explain.
- Q15.** Would you expect X-rays to be produced by a television picture tube? Explain.
- Q16. If the electron beam in a cathode-ray television tube is striking just one point on the screen at a time, how can we get a full picture? Explain. (See everyday phenomenon box 18.2.)
- Q17. What is the difference between the processes used to produce a black-and-white picture on a cathode-ray-tube TV set and those that produce a color picture? Explain. (See everyday phenomenon box 18.2.)
- Q18.** Following Roentgen's discovery of X-rays, Becquerel discovered a seemingly similar type of radiation given off by phosphorescent materials containing uranium or thorium. Was this new radiation the same as X-rays? Explain.
- Q19. Was it necessary for Becquerel's phosphorescent materials to be exposed to sunlight for them to exhibit natural radioactivity? Explain.
- Q20. What are two important differences that distinguish alpha particles from beta particles when they are passed through a magnetic field? Explain.
- \***Q21.** When alpha particles are scattered from a thin piece of gold foil, why do most of them go through with very little deflection? Explain.
- Q22. Does most of the mass of the atom reside inside or outside of the nucleus? Explain.
- \*Q23. What role did Rutherford's scattering experiment play in our developing understanding of atomic structure? Explain.
- Q24.** Would you expect electrons to be effective in deflecting an alpha-particle beam? Explain.
- \*Q25. How are the atomic spectra of hydrogen or other gaseous elements generated experimentally? How are they measured? Explain.
- Q26. Does the spectrum of hydrogen consist of randomly spaced wavelengths, or is there a pattern to the spacing? Explain.
- Q27.** According to Planck's theory, can light be emitted from a blackbody radiator in continuously varying amounts of energy for a given wavelength or frequency? Explain.
- Q28. According to Bohr's theory of the hydrogen atom, is it possible for the electron to orbit the nucleus with any possible energy? Explain.
- Q29. What happens to the excess energy when the electron jumps from a higher-energy orbit to a lower-energy orbit in the hydrogen atom? Explain.
- Q30.** Does an electron have a wavelength? Explain.
- Q31. Why can't we observe the wavelike properties of ordinary objects, like thrown balls traveling at ordinary speeds?
- Q32. As our technology improves, will it be possible to measure both position and momentum of a particle more accurately than the Heisenberg uncertainty principle predicts?
- Q33. According to the theory of quantum mechanics, is it possible to pinpoint exactly where an electron is located in an atom? Explain.
- Q34. The Bohr model of the hydrogen atom predicts a circular orbit for the electron about the nucleus; the theory of quantum mechanics predicts a three-dimensional probability distribution for locating the electron. Which of these views provides the more realistic picture of the hydrogen atom? Explain.
- Q35.** The chemical properties of sodium (Na), with 11 electrons, are similar to those of lithium (Li), which has just 3 electrons. How do we explain this fact?
- Q36.** Does helium (He), with two electrons (one more than hydrogen), react chemically with other substances more readily or less readily than hydrogen? Explain.
- Q37. Why does the second row in the periodic table have more elements than the first row, which contains hydrogen and helium? Explain.

## Exercises

- E1. If sulfur (S), with an atomic weight of 32, combines with fluorine (F), with an atomic weight of 19, to form the compound  $\text{SF}_6$ , what is the ratio of the mass of sulfur to fluorine that you would expect to react completely in this transformation?
- E2. If phosphorus (P), with an atomic weight of 31, combined with hydrogen (H), with an atomic weight of 1, to form phosphine ( $\text{PH}_3$ ), how many grams of phosphorus would react with 15 g of hydrogen?
- E3. If 112 g of silicon (Si) react completely with 64 g of oxygen (O) to form silica ( $\text{SiO}_2$ ), what is the atomic weight of silicon?
- E4. If aluminum (Al), with an atomic weight of 27, combines with oxygen (O), with an atomic weight of 8, to form the compound aluminum oxide ( $\text{Al}_2\text{O}_3$ ), how much aluminum is required to react completely with 72 g of oxygen?
- E5. If the mass of a hydrogen atom is  $1.67 \times 10^{-27}$  kg and the mass of an electron is  $9.1 \times 10^{-31}$  kg, how many electrons are required to have a mass equivalent to one hydrogen atom?
- E6. How many electrons would be required to produce 12 microcoulomb ( $12 \times 10^{-6}$  C) of negative charge? ( $e = -1.6 \times 10^{-19}$  C)
- E7. Suppose that an X-ray beam has a wavelength of  $6.0 \times 10^{-9}$  m. What is the frequency of these X-rays? ( $v = c = f\lambda$ )
- E8. Using the Rydberg formula, find the wavelength of the line in the Balmer series of the hydrogen spectrum for  $m = 5$ .
- E9. Using the Rydberg formula, find the wavelength of the spectral line for which  $m = 7$  and  $n = 3$ . Would this line be visible to the unaided eye? Explain.
- E10. Suppose that a photon has a wavelength of 520 nm (green).  
a. What is the frequency of this photon?  
b. What is the energy of this photon in joules ( $h = 6.626 \times 10^{-34}$  J·s)?
- E11. Suppose a photon has an energy of  $3.06 \times 10^{-19}$  J.  
a. What is the frequency of this photon? ( $h = 6.626 \times 10^{-34}$  J·s)  
b. What is the wavelength of this photon?  
c. What color does this represent? (See table 16.1.)
- E12. Suppose a photon has a frequency of  $7.50 \times 10^{14}$  Hz.  
a. What is the energy of this photon? ( $h = 6.626 \times 10^{-34}$  J·s)  
b. What is the wavelength of this photon?  
c. What color does this represent? (See table 16.1.)
- E13. An electron in the hydrogen atom jumps from an orbit in which the energy is 2.86 eV higher than the energy of the final lower-energy orbit.  
a. What is the frequency of the photon emitted in this transition? ( $h = 4.14 \times 10^{-15}$  eV·s. See example box 18.3.)  
b. What is the wavelength of the emitted photon?
- E14. A Bugatti Veyron Super Sport car is among the fastest in the world. It has a mass of approximately 1888 kg and can reach a top speed of 267 MPH (123 m/s). What is the de Broglie wavelength (in meters) associated with this vehicle when moving at its top speed? ( $h = 6.626 \times 10^{-34}$  J·s)

## Synthesis Problems

- SP1. An electron beam in a cathode-ray tube passes between two parallel plates that have a voltage difference of 500 V across them and are separated by a distance of 4 cm, as shown in the diagram.  
a. In what direction will the electron beam deflect as it passes between these plates? Explain.  
b. Using the expression for a uniform field,  $\Delta V = Ed$ , find the value of the electric field in the region between the plates.  
c. What is the magnitude of the force exerted on individual electrons by this field? ( $F = qE$ ,  $q = 1.6 \times 10^{-19}$  C)  
d. What are the magnitude and direction of the acceleration of an electron? ( $m = 9.1 \times 10^{-31}$  kg)  
e. What type of path will the electron follow as it passes through the region between the plates? Explain.
- SP2. Study the energy-level diagram shown in figure 18.20. The Balmer series of spectral lines all involve transitions to the  $n = 2$  energy level, and the Lyman series in the ultraviolet involves transitions to the  $n = 1$  level. The energies are all negative as a result of the negative potential energy for two charges of opposite sign.  
a. Which transition in the Balmer series produces the smallest frequency photon (and the largest wavelength)?  
b. What is the energy difference in joules for the two levels involved in the transition of part a?  
c. What are the frequency and wavelength of the photon emitted in this transition?  
d. Similarly, find the frequency and wavelength of the photon with the longest wavelength in the Lyman series.
- SP3. When an electron is removed completely from an atom, the atom is ionized. An ionized atom has a net positive charge, because an electron has been removed.  
a. From the energy-level diagram in figure 18.20, how much energy is required to ionize a hydrogen atom when it is in its lowest energy level?  
b. How much energy is required to ionize the atom when it is in the first excited state above the lowest level?



SP1 Diagram

- c. If an electron with zero kinetic energy was “captured” by an ionized hydrogen atom and went immediately to the lowest energy level, what wavelength would you expect to observe for the photon emitted in this transition?
- SP4. Suppose an electron ( $m = 9.1 \times 10^{-31}$  kg) is moving with a velocity of 1800 m/s.
- a. What is the momentum of this electron?
- b. What is the de Broglie wavelength of this electron?
- c. How does this wavelength compare to those of visible light? (See figure 16.5.)

## Home Experiments and Observations

- HE1. Obtain some red or blue liquid food coloring from your kitchen or local grocery. Prepare two glasses or transparent plastic cups containing equal amounts of water, one drawn from the cold tap and the other drawn from the hot tap. Drop one drop of food coloring into each cup and observe what happens. (Do not stir once the food coloring has been added.)
- a. Describe the changes that take place over several minutes in time until the food coloring is well dispersed in both cups. What differences do you note between the cups with the cold and hot water?
- b. Develop an explanation for your observations. Do they suggest the presence of tiny particles, such as molecules or atoms?
- HE2. If you have an old CRT color television available, turn it off and take a close look at the screen. Using a magnifying glass will help you get a good view of the detail.
- a. Describe the pattern of lines you observe. Produce a careful sketch showing the arrangement of the lines. How many lines are there approximately?
- b. If a black-and-white CRT television set is handy, compare the pattern on its screen to the color set. What differences can you describe?



# CHAPTER 19

Keith Eng, 2008

## The Nucleus and Nuclear Energy

### Chapter Overview

The story of how physicists explored the nucleus and its structure is told in this chapter, including the discovery of nuclear fission just before World War II and the wartime effort to invent the atomic bomb. The postwar desire to find peaceful uses for the atom led to the development of commercial power plants, although this era also saw the invention of the hydrogen (fusion) bomb and a rapid buildup of the nuclear arsenals of the major world powers. Our goal is to understand the underlying science of these issues.

### Chapter Outline

- 1 The structure of the nucleus.** What is the nucleus made of, and how do the pieces fit together? What is the distinction between different isotopes of the same element?
- 2 Radioactive decay.** What is radioactive decay, and how does it relate to changes in the nucleus? Why can radioactivity be dangerous?
- 3 Nuclear reactions and nuclear fission.** What are nuclear reactions, and how do they differ from chemical reactions? How was nuclear fission discovered? What is a chain reaction?
- 4 Nuclear reactors.** How do nuclear reactors work? What are the functions of the moderator, the control rods, the coolant, and other reactor components? What do nuclear wastes consist of?
- 5 Nuclear weapons and nuclear fusion.** How does a nuclear bomb work? What is nuclear fusion, and how can it be used to release energy?

In 2011, the news media were full of reports and comments on a serious nuclear accident at the Fukushima Daiichi nuclear power plant in Japan, due to an earthquake and subsequent tsunami (see everyday phenomenon box 19.2 later in this chapter). While there were no deaths caused by radiation exposure (approximately 18,500 people died due to the earthquake and tsunami), the fears of the public about nuclear power were dramatically reawakened.

The United States has about 60 nuclear power plants producing electric power, submarines that use nuclear reactors as their power source, and many smaller reactors used for research and other purposes. Most of these reactors have operated with only minor problems and have had minimal impact on their surroundings. Nevertheless, the environmental consequences and economics of nuclear power have been extremely controversial issues over the past five decades.

What goes on inside a nuclear reactor? How do we derive power from uranium, and what nuclear wastes are generated? Need we fear those benign-looking clouds that billow from the cooling towers (fig. 19.1)? Can a reactor explode like a nuclear bomb? What is the difference between nuclear fission and nuclear fusion? If you know the answers to these questions, you will be less influenced by extremists on either side of the issue who push simple but misleading views.

The development of our knowledge of the nucleus of the atom is one of the most fascinating tales of twentieth-century science. The political consequences of nuclear weapons and nuclear power were critical components of that story. These issues, more than any other, have thrust science and physics into the cauldron of national and international policy, and nuclear issues, in particular, have become part of our common concern as citizens.



**Figure 19.1** The large cooling tower is often the most prominent feature of a modern nuclear power plant. What is the source of energy in such a plant? *hornyak/Shutterstock*

## 19.1 The Structure of the Nucleus

Scientists began to understand the structure of the nucleus only in the twentieth century. Even the existence of an atomic nucleus was not suspected until Rutherford's famous alpha-particle scattering experiments performed between 1909 and 1911 (see section 18.3). The idea that this tiny center of the atom also has a structure that we can decipher may seem amazing.

What are the building blocks from which the nucleus is constructed? Ernest Rutherford, who is credited with the discovery of the nucleus, also played a major role in answering this question. The evidence came from more scattering experiments, which are the major tool for probing the nucleus and other subatomic particles.

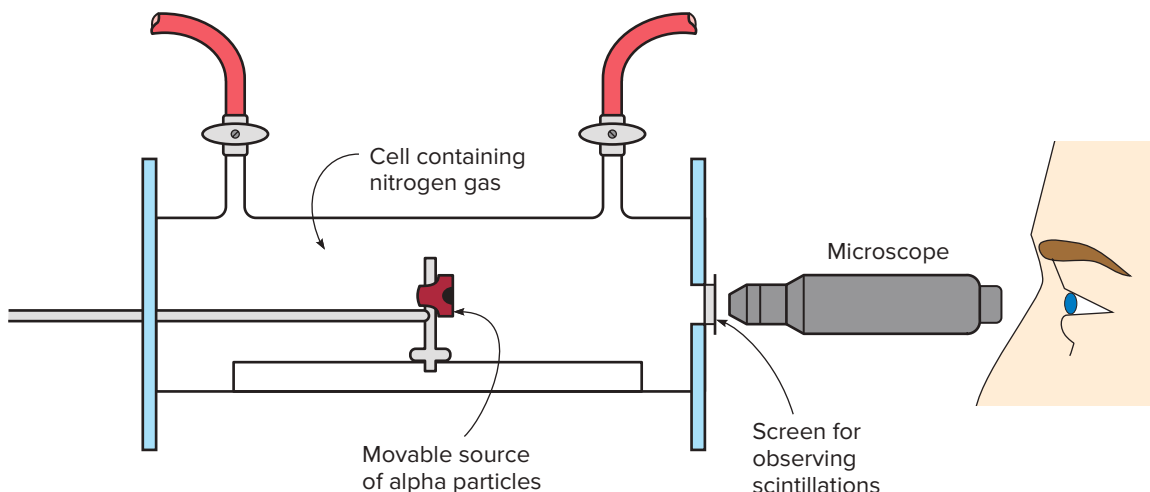
### How was the proton discovered?

Rutherford performed the experiment that uncovered the first nuclear building block in 1919. Once again, he used alpha particles as his probe. Figure 19.2 shows a conceptual diagram of

this scattering experiment. A beam of alpha particles was used to bombard a cell containing nitrogen gas. As expected, some of the alpha particles went through the sample without hitting anything, and others were deflected (scattered) by the nuclei of the nitrogen atoms. The deflected particles could be observed with scintillation detectors (see section 18.3).

The unexpected result of this experiment was the emergence of a different particle from the cell containing the nitrogen. These new particles were positively charged, like the alpha particles, but could be distinguished by how far the particles traveled in air and by other features. In fact, the new particles behaved like the nuclei of hydrogen atoms that Rutherford had observed in earlier experiments when he bombarded hydrogen gas with alpha particles. The mass of the hydrogen atom is approximately one-fourth that of an alpha particle, which is the nucleus of a helium atom, as noted in chapter 18.

Finding hydrogen nuclei emitted from a cell that contained no hydrogen hinted at an exciting possibility: Perhaps the hydrogen nucleus was a basic constituent of the nucleus of other elements. It was already known that the atomic masses of many elements were close to being integer



**Figure 19.2** A drawing of the apparatus used in Rutherford's scattering experiment, which resulted in the discovery of the proton. Nitrogen gas was the target for the alpha particles.

multiples of the atomic mass of hydrogen. The atomic mass of nitrogen, for example, is approximately 14 times the atomic mass of hydrogen, while carbon is approximately 12 times and oxygen 16 times the atomic mass of hydrogen. These masses could be explained if the nuclei of these elements were made up of 12, 14, and 16 hydrogen nuclei for carbon, nitrogen, and oxygen, respectively.

Further experiments by Rutherford and others showed that hydrogen nuclei could also be ejected from sodium and other elements by bombarding them with alpha particles. We now call this particle a **proton**—it is the nucleus of the hydrogen atom, as well as a component of other nuclei. A proton has a charge  $+e = 1.6 \times 10^{-19}$  C, opposite in sign but identical in magnitude to the charge of the electron  $-e$ . Its mass is much larger than the electron's, however, and is similar to the mass of the hydrogen atom. The mass of a proton is approximately 1835 times the mass of the electron.

### How was the neutron discovered?

The hypothesis that the nuclei of different elements could be made simply of protons had some serious problems, the most obvious of which was the charge of the nucleus. From nitrogen's place in the periodic table and other evidence, the charge of the nitrogen nucleus should be  $+7e$  rather than  $+14e$ . If there were 14 protons in the nucleus of the nitrogen atom, the nuclear charge would be too large. Likewise, carbon and oxygen have nuclear charges of  $+6e$  and  $+8e$ , respectively, rather than 12 or 16 times  $e$ .

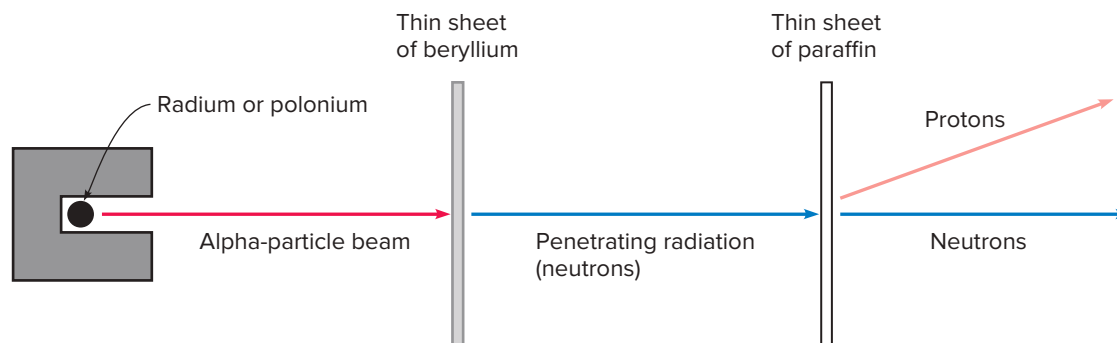
For a while, physicists considered the possibility that electrons were also present in the nucleus, partially neutralizing the extra charge of the protons. This view had some serious drawbacks, however, in light of the new insights of quantum mechanics. The energies of electrons confined to the very small region of the nucleus would have to be much larger than the measured energies of the electrons emerging as beta rays in radioactive decay. Therefore, it did not seem

likely that electrons existed as separate particles in the nucleus.

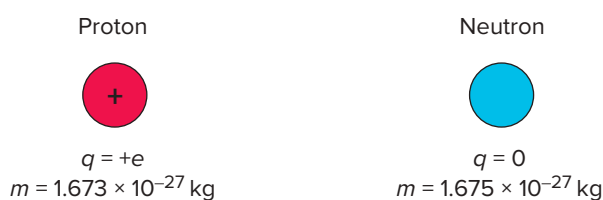
It took several years to solve this riddle. Yet another scattering experiment, performed by Walther Bothe and Wilhelm Becker in Germany around 1930, provided the breakthrough. Bothe and Becker bombarded thin beryllium samples with alpha particles and found that a very penetrating radiation was emitted. Because gamma rays were the only radiation known to be so penetrating, Bothe and Becker originally assumed that gamma rays were involved. Other experiments, however, showed that this new emission had an even greater ability to pass through lead than gamma rays and possessed other properties quite unlike those of gamma rays.

In 1932, a British physicist, James Chadwick (1891–1974), showed that this new emission from beryllium behaved like a neutrally charged particle with a mass roughly equal to that of the proton. Chadwick's experiment used the penetrating emission from the alpha bombardment of beryllium to bombard a piece of paraffin (fig. 19.3). Paraffin is a compound of carbon and hydrogen, and hydrogen nuclei (protons) emerged from the paraffin when placed in the path of the penetrating radiation coming from the beryllium. If a new neutral particle with a mass equal to the proton was colliding with protons in the paraffin, it neatly explained the energies of the protons emerging from the paraffin. This new particle was called a **neutron**—it has no charge, and its mass is very close to the proton's mass.

Chadwick's discovery of the neutron settled the question of the basic building blocks of the nucleus (fig. 19.4): If the nucleus is made of neutrons and protons, we can explain both the charge and the mass of the nucleus. Nitrogen, for example, can have a nucleus made up of seven protons and seven neutrons for a total mass 14 times the mass of hydrogen and a nuclear charge 7 times that of hydrogen. You can easily deduce the required numbers of protons and neutrons for carbon and oxygen. The numbers for several elements are shown in figure 19.5.










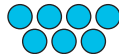

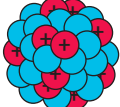
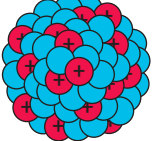
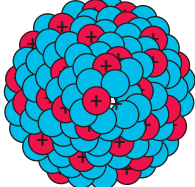
**Figure 19.3** A diagram of Chadwick's experiment. Radiation coming from the beryllium target was used to bombard a paraffin target.



**Figure 19.4** The basic building blocks of the nucleus are the proton and the neutron.

### What are isotopes?

Another puzzle was also solved with the discovery of the neutron. It had been known for some time that atoms of the same element could have different values of nuclear mass. Nuclear masses were measured with high accuracy by passing nuclei of known velocity through a magnetic field and observing how much their paths were bent by the magnetic force on the positively charged nucleus. For example,

Isotope	Symbol	Number of protons	Number of neutrons	Relative size
Helium-4	${}^2_2\text{He}^4$	2 	2 	
Beryllium-9	${}^4_4\text{Be}^9$	4 	5 	
Nitrogen-14	${}^7_7\text{N}^{14}$	7 	7 	
Chlorine-37	${}^{17}_{17}\text{Cl}^{37}$	17	20	
Iron-56	${}^{26}_{26}\text{Fe}^{56}$	26	30	
Uranium-238	${}^{92}_{92}\text{U}^{238}$	92	146	

**Figure 19.5** The proton and neutron numbers for the most common isotopes of several elements. The nucleus gets larger as the number of protons and neutrons increases.



chlorine was known from chemistry to have an average atomic mass 35.5 times that of hydrogen. When chlorine ions were passed through a magnetic field, however, two different masses were present, one 35 times hydrogen and the other 37 times hydrogen. Their chemical properties were identical—both behaved like chlorine.

Today, we call different-mass versions of the same element **isotopes**. Different isotopes have the same number of protons in the nucleus but different numbers of neutrons. The two common isotopes of chlorine, for example, both have 17 protons in the nucleus, but one has 18 neutrons for a total mass number of 35, while the other has 20 neutrons for a total mass number of 37. (The mass number is the sum of the proton and neutron numbers.) Table 19.1 gives other examples.

**Table 19.1**

Neutron and Proton Numbers for Different Isotopes of the Same Elements

Name	Symbol*	Protons	Neutrons
Hydrogen-1	${}_1\text{H}^1$	1	0
Hydrogen-2 (deuterium)	${}_1\text{H}^2$	1	1
Hydrogen-3 (tritium)	${}_1\text{H}^3$	1	2
Carbon-12	${}_6\text{C}^{12}$	6	6
Carbon-14	${}_6\text{C}^{14}$	6	8
Chlorine-35	${}_{17}\text{Cl}^{35}$	17	18
Chlorine-37	${}_{17}\text{Cl}^{37}$	17	20
Uranium-235	${}_{92}\text{U}^{235}$	92	143
Uranium-238	${}_{92}\text{U}^{238}$	92	146

\*See section 19.2 for an explanation of the notation used here.

The chemical properties of an element are determined by the number and arrangement of the electrons outside of the nucleus, as discussed in chapter 18. For a neutral atom with a net charge of zero, the number of electrons outside the nucleus must equal the number of protons inside the nucleus, which is called the **atomic number**. Nitrogen, for example, has an atomic number of 7: There are 7 protons in the nucleus and 7 electrons orbiting the nucleus. There also happen to be 7 neutrons in the nucleus, but in general the neutron number is *not* equal to the atomic number. Except for the lightest elements, the neutron number is generally larger than the atomic number.

With the discovery of the neutron in 1932, many pieces of the puzzle fell into place. Atomic masses, as well as the chemical properties of atoms, could now be explained. Physicists began inventing models of the nucleus and designing new experiments to test these models. Perhaps most importantly, the neutron provided a powerful new probe for exploring the structure of the nucleus. Because it has no charge, a neutron can penetrate the nucleus and begin to rearrange it. The proton and the alpha particle, on the other

hand, are both positively charged and, therefore, repelled by the positive charge of the nucleus. A host of new experiments were begun, and some produced even more spectacular surprises than those described here.

A series of scattering experiments performed by Rutherford and other physicists gave clues to the building blocks of the nucleus. The proton, which is the nucleus of the hydrogen atom, was found in other nuclei as well. The neutron, which has a mass almost equal to that of the proton but zero charge, could also be generated in scattering experiments. Together, the proton and neutron account for both the mass and the charge of different nuclei, as well as the existence of different isotopes of the same element.

## 19.2 Radioactive Decay

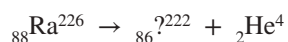
Becquerel discovered natural radioactivity in 1896, as described in section 18.3. By 1910, Rutherford and others had demonstrated that one element was actually being changed into another during **radioactive decay**. The nucleus of a radioactive atom itself is unstable, and its structure changes when a decay occurs. How can our new insights into nuclear structure help to illuminate this phenomenon?

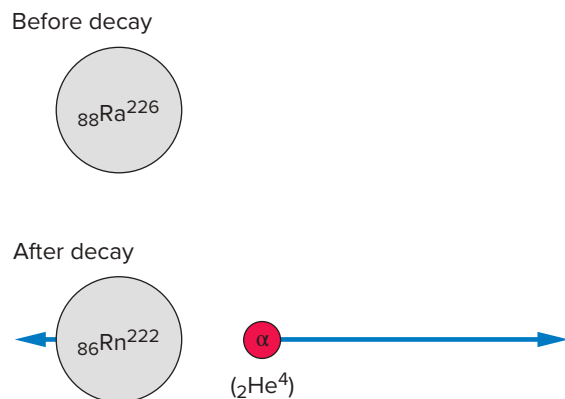
### What happens in alpha decay?

Radium, which was isolated and identified at the turn of the twentieth century by Marie and Pierre Curie, was one of the first radioactive elements to be studied extensively. Radium was found in the uranium ore, pitchblende, but was soon shown to be much more radioactive than uranium itself. Alpha particles, which Rutherford identified as the nuclei of helium atoms, were the primary radiation emitted in the decay of radium.

The dominant isotope of radium found in pitchblende contains a total of 226 **nucleons** (neutrons and protons) in its nucleus. We call this isotope *radium-226* and often write it as  ${}_{88}\text{Ra}^{226}$ , where Ra is the chemical symbol for radium, the subscript 88 is the atomic number, and the superscript 226 is the **mass number**, the total number of neutrons and protons. Because the atomic number is 88, this means there are 88 protons and 138 neutrons (226 – 88) in the nucleus of this isotope.

If we know that radium-226 emits alpha particles, we can figure out what element results from its decay. The process is straightforward: We know how many protons and neutrons are contained in both the radium and the alpha particle (a helium nucleus), so we also know how many of each are left in the decay product, or *daughter* element. We often write a reaction equation to help keep track of the numbers and to serve as a shorthand for describing the reaction:





**Figure 19.6** Alpha decay of radium-226. The daughter isotope is radon-222.

Here we have found the atomic number (86) of the unknown element by subtracting the atomic number of helium, 2, from radium, 88. The mass number is found similarly: Subtracting 4 from 226 yields the mass number of 222. Both the atomic numbers and the mass numbers must add to the same total on either side of the reaction equation. The unknown element can then be identified by looking in a periodic table (in appendix E or online) to find which element has an atomic number of 86. It turns out to be the noble gas radon (Rn), so the daughter nucleus indicated by the question mark is radon-222 ( ${}_{86}\text{Rn}^{222}$ ).

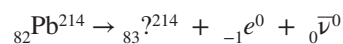
The alpha decay of radium-226 is illustrated in figure 19.6, where the alpha particle is shown emerging with a much larger velocity than the recoil velocity of the radon nucleus as required by conservation of momentum (see chapter 7). If the initial momentum of the system was zero, the alpha particle and the radon nucleus must have equal but oppositely directed momenta after the decay. Because the alpha particle has a much smaller mass than the radon nucleus, its velocity must be much larger than that of the helium nucleus for the momenta to be equal in magnitude ( $p = mv$ ).

Even though we did not obtain gold, we find that the alchemist's dream of turning one element into another does happen in radioactive decay and other nuclear reactions. The daughter isotope, radon-222, is itself radioactive and undergoes alpha decay to produce polonium-218, which in turn undergoes alpha decay to yield lead-214. Although lead-214 is not a stable isotope, lead is often the end product of the radioactive decay of heavier elements. For an interesting application of alpha decay, see everyday phenomenon box 19.1.

### What happens in beta and gamma decay?

Lead-214 undergoes beta decay—the particle emitted in beta decay is either an electron or a *positron* (a positively charged version of the electron). In the case of lead-214, an ordinary (negatively charged) electron is emitted. The mass of an electron is so small it can be ignored on the scale of nuclear masses—its mass number is effectively zero.

Because an electron is negatively charged, its charge or atomic number is  $-1$ , so the reaction equation takes the form

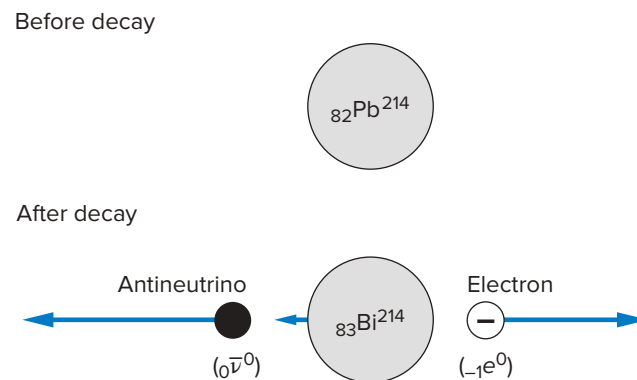


The third particle appearing on the right-hand side of the beta-decay reaction equation is called an *antineutrino* and is represented by the Greek letter nu ( $\nu$ ). The bar over the symbol indicates an **antiparticle**. All elementary particles also have antiparticles. Antiparticles have identical masses but opposite-sign charges if they are charged. For example, the positron is the antiparticle of an electron. Antiparticles will annihilate each other, releasing energy in other forms, if they interact.

The antineutrino had not been directly observed in beta decay but was included to conserve energy. Because the electrons in beta decay emerge with a range of energies, physicists reasoned that something else must be involved to account for the remaining energy. Neutrinos were not actually detected until 1957, but physicists believed in their existence for many years before, because of their faith in the principle of conservation of energy. Neutrinos (and antineutrinos) have an extremely small mass and no charge, so they do not affect the charge and mass numbers in the reaction equation.

Here again, we see that the mass numbers and charge numbers add up on either side of the reaction equation. The atomic number of the resulting element is 83, because  $83 - 1 = 82$  is the original atomic number of the lead (Pb) isotope. Looking up the atomic number 83 in the periodic table shows that bismuth-214 is the daughter element in this decay (fig. 19.7). One of the neutrons inside the nucleus of lead-214 has been changed to a proton, yielding a nucleus with a higher atomic number. Thus, we could substitute  ${}_{83}\text{Bi}^{214}$  for the question mark in the reaction equation.

Through a series of further beta and alpha decays, bismuth-214 decays finally to a stable isotope of lead: lead-206. Some of the isotopes involved in this decay chain also emit gamma rays, which are high-energy photons. Because the emitted particle in this case is a photon, which has no charge or mass, neither the mass number nor the charge



**Figure 19.7** Beta decay of lead-214. The daughter isotope, bismuth-214, has a higher atomic number than lead.

## Everyday Phenomenon

## Box 19.1

## Smoke Detectors

**The Situation.** Smoke detectors are ubiquitous in our lives, thank goodness. Many hundreds of lives have been saved by smoke alarms. Most homes, apartments, and offices have smoke detectors installed, often in hallways (see photograph). Most people have probably had the experience of burning dinner and having the smoke alarm go off.



A typical smoke detector mounted on a ceiling. *Digital Vision/Getty Images*

How do smoke detectors work? How does radiation play a role in smoke detectors? Many everyday phenomena depend on the properties of radiation. The field of medicine is full of examples—medical imaging, radiation treatment of cancer, etc. However, many people don't realize that smoke detectors are cleverly designed to take advantage of a property of alpha particles.

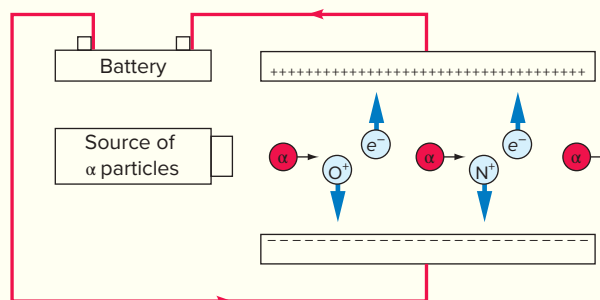
**The Analysis.** Alpha particles are simply a helium nucleus, consisting of two neutrons and two protons. They are much more massive than beta particles (electrons) and gamma rays. Because of their relative size, alpha particles cannot travel very far in air. Nitrogen and oxygen molecules make up 89% of the air we breathe. Alpha particles bump into the nitrogen and oxygen molecules in the air and lose their energy. If the air is filled with smoke particles, they lose their energy much more rapidly and can barely travel any distance at all! This characteristic of alpha radiation helps to make a very sensitive smoke detector.

In a smoke detector, there is a source of alpha particles called americium-241. There are no stable isotopes of americium; thus, it is extremely rare in nature. It was originally discovered at a nuclear reactor at the University of Chicago by bombarding plutonium with neutrons. Glenn Seaborg, who worked on the Manhattan Project and codiscovered 10 elements, named the new element americium, in honor of the continent

where it was discovered. All the americium used in smoke detectors is produced in nuclear reactors.

When the alpha particles bump into the nitrogen and oxygen molecules, they remove electrons from those molecules, causing them to become **ionized**. An ionized molecule, also called an ion, is a molecule that is no longer neutral. The number of protons in the nucleus is now greater than the number of electrons, because one or more of the electrons have been removed by the interaction with the alpha particle. This produces negatively charged electrons and positively charged nitrogen and oxygen ions.

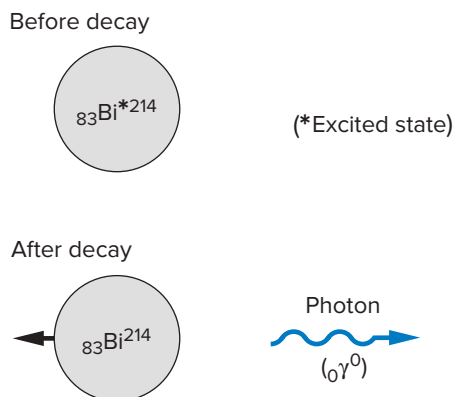
In the smoke detector, there are two plates, one positively charged and one negatively charged (see the diagram). Because unlike charges attract each other, the electrons head toward the positively charged plate, and the positive nitrogen and oxygen ions head toward the negatively charged plate. This creates an electric current. This is why it is important to change the battery in your smoke detector regularly, because it is the battery that creates the positive and negative charges on the plates.



A simple diagram showing the basic idea of how a smoke detector works. Additional circuitry (not shown) is necessary to detect the decrease in the current that activates the alarm.

When the electric current is present, all is well. However, if there are smoke particles in the air, the current decreases and an alarm is triggered. One reason the current decreases is that the alpha particles are absorbed by the smoke particles and thus prevented from creating many of the ions. The other reason is that the smoke particles interact with what ions are present, contributing electrons, so they become electrically neutral again.

Alpha particles are amazingly easy to stop. The dead layer of your skin on the outside of your body is more than sufficient to stop any alpha particle. A single sheet of paper or a layer of clothing can also stop them. Thus, the detector itself generally absorbs all the alpha radiation produced in the smoke detector. If any of the alpha radiation escapes from the detector, it is absorbed within a few centimeters in the air. Think how many lives have been saved because of this clever use of the properties of alpha radiation!



**Figure 19.8** Gamma decay of bismuth-214. The daughter isotope is a more stable (lower-energy) version of the original bismuth-214.

number changes in a gamma decay. We are left with merely a more stable version of the original isotope (fig. 19.8).

Isotopes that emit gamma rays are used extensively in medical applications. Because the gamma rays have no charge or mass, they don't interact much with matter and therefore have greater penetrating power than alpha or beta particles. They also cause significantly less biological damage. Many nuclear medicine diagnostic procedures involve introducing a radioactive isotope into the body and then imaging the concentration of radioactivity. Among other things, this allows doctors to determine without invasive surgery if an organ is working properly, if cancer is present, or if repair is taking place somewhere in the body (indicating an injury).

### How do we describe the rate of decay?

How long does it take for these different decays to happen? The different kinds of radioactive decay are all spontaneous events that happen randomly. There is no way of predicting exactly when a specific unstable nucleus will throw out a particle and change to a different isotope.

Different radioactive isotopes have different average or characteristic times that elapse before they decay. The concept of **half-life** describes this characteristic time: The half-life is the time required for half of the original number of atoms to decay. For example, the half-life of radon-222 is about 3.8 days. If we started with 20,000 atoms of radon-222, 3.8 days later we would have about 10,000 remaining. The other half would have decayed to polonium-218 ( ${}_{84}\text{Po}^{218}$ ). In two half-lives, or 7.6 days, half of the remaining atoms would have decayed, leaving only 5000 atoms of radon-222. In three half-lives, we would be down to 2500, and in four half-lives this number would be halved again, yielding 1250 atoms. The number of polonium-218 atoms we would have created at this point would be 18,750 ( $20,000 - 1250$ ).

Because the number of radon-222 atoms is reduced by half each time 3.8 days passes, it does not take many half-lives to reduce the remaining number of atoms of an isotope to a tiny fraction of the original amount. After 10 half-lives,

## Example Box 19.1

### Sample Exercise: A Medical Isotope

Technetium-99 is a radioactive isotope with a half-life of 6.0 hours that is used in bone scans and other medical tests. It emits gamma radiation.

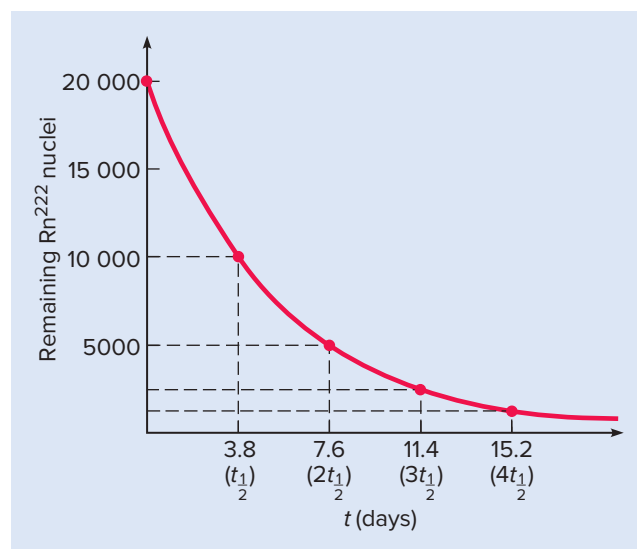
- If a sample of technetium-99 is prepared a half-day (12 hours) before it is used, what fraction of the original amount of the isotope remains at the time of use?
- What fraction remains one day (24 hours) after preparation?

$$\begin{aligned} \text{a. } t_{\frac{1}{2}} &= 6.0 \text{ h} & \frac{t}{t_{\frac{1}{2}}} &= \frac{12 \text{ h}}{6 \text{ h}} = 2 \\ t &= 12 \text{ h} \\ \text{fraction remaining} &= ? & \text{fraction} &= \frac{1}{2} \times \frac{1}{2} = \frac{1}{4} \end{aligned}$$

$$\begin{aligned} \text{b. } t_{\frac{1}{2}} &= 6.0 \text{ h} & \frac{t}{t_{\frac{1}{2}}} &= \frac{24 \text{ h}}{6 \text{ h}} = 4 \\ t &= 24 \text{ h} \\ \text{fraction remaining} &= ? & \text{fraction} &= \frac{1}{2} \times \frac{1}{2} \times \frac{1}{2} \times \frac{1}{2} = \frac{1}{16} \end{aligned}$$

or 38 days, the number of atoms remaining from the original 20,000 would be just 20 atoms, or a thousandth of the original number. See example box 19.1.

This decay process is graphed in figure 19.9. The curve that results is called an *exponential decay curve*, because mathematically it can be represented by an exponential function. **Exponential decay** or growth occurs in nature whenever the number of decays or additional events is proportional to the total number of candidates for decay or growth. This is true for many random processes.



**Figure 19.9** Decay curve for radon-222. The amount remaining decreases by one-half every 3.8 days, the half-life.

The half-lives of different radioactive isotopes vary enormously. The half-life of radium-226 is 1620 years, for example, which is quite short compared to the 4.5-billion-year half-life of the common isotope of uranium: uranium-238. At the other extreme, polonium-214 has a half-life of just 0.000164 second. It does not stick around long! The longer the half-life, the more stable the isotope.

On the other hand, the shorter the half-life, the greater the rate of radioactivity. From an environmental standpoint, isotopes with intermediate half-lives pose the greatest problem. An isotope with a very short half-life is highly radioactive while it lasts, but it decays quickly and does not remain dangerous. An isotope with an extremely long half-life, like uranium-238, is not highly radioactive, although it can be a hazard if enough is present. An isotope such as strontium-90, with a half-life of 28.8 years, is much more radioactive than uranium-238 and remains in the environment long enough to pose serious problems. Strontium-90 is sometimes present in fallout from bomb tests and nuclear accidents.

### Why is radioactivity hazardous to our health?

Radioactivity is dangerous, because the emitted particles—alpha particles, beta rays (electrons), and gamma rays—can alter chemical compounds that make up our cells. These alterations can cause cancer and other damage. In high enough doses, these alterations produce radiation sickness and death. The effects of very low doses are still being debated. Some scientists believe that any dose is potentially damaging, but others hold that very low levels may have beneficial effects that counter the negative effects.

Because their half-lives are similar to the estimated age of the Earth, uranium-238 and thorium-232 have not completely decayed and are still present naturally in our environment. They appear in trace amounts in all rocks and soils and in more concentrated amounts in uranium ores. One of the elements produced as U-238 decays is the gas radon, which appears as the largest source of background radiation in table 19.2. Radon is an alpha emitter and is an odorless, tasteless gas. Alpha particles cannot penetrate even the dead layer of skin on the outside of your body. However, if you inhale them (which is easy to do, because they are in the form of a gas), the alpha particles deposit energy inside your body and can cause some biological damage. It is important to note that the amount of radon varies by location, season, type of home construction, and other factors. The radon test kit shown at the beginning of this chapter is an example of a way to estimate your own radon exposure.

Although a variety of units are used for measuring amounts of ionizing radiation and their impact on human tissue, the unit most commonly used for comparison of absorbed doses of differing kinds of ionizing radiation (X-rays, natural radioactivity, and so on) is the *rem*. Rem is an acronym for *roentgen equivalent in man*—the roentgen is a unit

**Table 19.2**

Background Radiation Sources	
Sources	mrems/yr
Natural sources	
Inhaled radon	200
Cosmic rays	27
Terrestrial radioactivity	28
Internal radioactivity	40
	295
Human-produced sources	
Medical	53
Consumer products	10
Other	1
	64

of the amount of ionizations produced by radiation. The rem takes into account differing effects of various types of radiation on human tissue, measuring the amount of energy absorbed per unit mass of tissue.

A whole-body dose of 600 rems usually is lethal. Much smaller doses can also produce damage, however, and these are generally quoted in *millirems* (mrems). One millirem is one-thousandth of a rem. On average, people in the United States receive about 295 mrems yearly from natural sources and another 64 mrems yearly from human-produced sources. (An easy way to remember this is that the total from both sources is almost 365 mrem, or 1 mrem a day over the course of a year.) As table 19.2 shows,\* the largest human-produced source is medical procedures, such as diagnostic X-rays and radioactive isotopes used in nuclear medicine.

Both the natural background and the human-produced sources vary widely, depending on where you live and what medical procedures you undergo. The average dose received by people in the United States from nuclear-power sources is not significant on this scale, but individuals working in the industry may be exposed to larger amounts. Current standards place a limit of 5 rems a year (5000 mrems/yr) on nuclear workers, X-ray technicians, and other people exposed to radiation in their occupations.

We are constantly exposed to very low levels of radioactive emissions from trace amounts of the isotopes of Th-232 and U-238 and their decay products, as well as from cosmic rays that impinge on Earth from space. Since the beginning of humankind, we have been exposed to this low-level background radiation, and our bodies have developed impressive repair capabilities. Only when levels of radiation exposure become much greater than natural background radiation is there some cause for concern.

\*For further discussion, see Health Effects of Low-Level Radiation (*Physics Today*, August 1991, pp. 34–39), from which this table was adapted.

In radioactive decay, the nucleus of the radioactive atom is modified as it emits different kinds of particles. In alpha decay, helium nuclei are emitted, leaving the daughter isotope with lower atomic and mass numbers. In beta decay, electrons or positrons are emitted, which changes the atomic number but not the mass number. In gamma decay, a high-energy X-ray is emitted, which does not change either the atomic or the mass number of the original isotope. Unstable isotopes are like time bombs waiting to go off. They have a characteristic decay time that we often describe in terms of the half-life.

### 19.3 Nuclear Reactions and Nuclear Fission

We have seen that the nucleus can change spontaneously in radioactive decay. One element changes to another when this happens. Is it possible for us to cause such changes to occur experimentally rather than waiting for spontaneous decays?

The discovery of the neutron in 1932 provided a new probe for rearranging the nucleus. As a result of this discovery, nuclear physics became a field of intense activity during the 1930s. This work produced some unanticipated results with enormous implications for both science and human affairs.

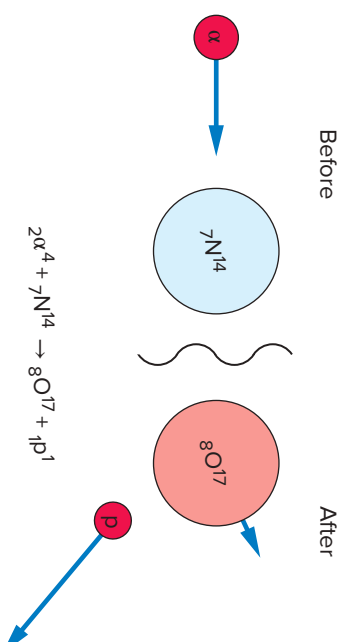
#### What are nuclear reactions?

We have already encountered experimentally produced changes in the nucleus: Rutherford's discovery that protons are emitted from nitrogen nuclei when they are bombarded by alpha particles is an example of such a change. We could write the reaction equation for Rutherford's experiment as



The alpha particle is a helium nucleus, and the emitted proton is a hydrogen nucleus, as indicated in the equation. The other product of the reaction is an element with an atomic number of 8, which turns out to be oxygen (Fig. 19.10). Oxygen-17 is not the most common isotope of oxygen (which is oxygen-16), but it is found in nature as a stable isotope.

This is an example of a **nuclear reaction**. Note that the charge and mass numbers add up to the same total on either side of the equation: The total charge or atomic number is 9 and the total mass number is 18. (This was also true of the radioactive-decay equations in section 19.2.) The mass and atomic numbers are used to identify the other reaction product, oxygen-17, but we could also confirm this result by analyzing the gas found in the cell after the experiment. Oxygen would be found, even though none was present at the beginning of the experiment. Unlike a chemical reaction, which involves rearrangement of the electrons orbiting the nucleus, the elements themselves can change in a nuclear reaction.



**Figure 19.10** The collision of an alpha particle and a nitrogen nucleus results in a proton being emitted and an oxygen-17 nucleus remaining in place of nitrogen.

The emission of neutrons from beryllium samples bombarded by alpha particles is another example of a nuclear reaction. The reaction equation in this case would be



The neutron has no charge, so its atomic or charge number is 0, and its mass number, like the proton, is 1. The other reaction product, carbon-12, is identified by looking in the periodic table to find which element has an atomic number of 6. The resulting isotope of carbon turns out to be the most common one. After the experiment has been performed, we will find small amounts of carbon present in the originally pure beryllium target.

#### How are energy and mass involved in nuclear reactions?

One of the original mysteries of radioactivity was the question of where the energy comes from. The alpha particles, beta rays, or gamma rays emerged with large kinetic energies, even though Becquerel's uranium samples were stored in a dark drawer for weeks at a time. What was the source of this energy?

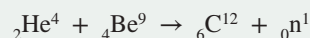
The answer was found in Einstein's famous  $E = mc^2$  relationship, developed as part of his theory of relativity about 10 years after the discovery of radioactivity. The meaning of this equation is that mass and energy are equivalent: Mass is energy and energy is mass. (This equation will be explained in more detail in chapter 20.) The constant  $c^2$ , the speed of light squared, is a unit-conversion factor that allows us to convert mass units to energy units, and vice versa. If the mass of the products is less than that of the reactants, the energy represented by this mass difference shows up in other forms, usually as the kinetic energy of the emerging particles.

This idea is illustrated for the beryllium reaction in the computations shown in example box 19.2. The masses for the isotopes and particles involved are given in atomic mass units (or unified mass units, u), which are based on the mass of the carbon-12 atom. The mass of carbon-12 is exactly 12.000 000 u, by definition of the atomic mass unit. (One atomic mass unit is

## Example Box 19.2

### Sample Exercise: Transforming Mass Energy into Kinetic Energy

The nuclear masses for the reactants and products of the reaction



are provided here. Using these values and Einstein's  $E = mc^2$  relationship, calculate the energy released in this reaction.

Reactants		Products	
Be <sup>9</sup>	9.012 186 u	neutron	1.008 665 u
He <sup>4</sup>	+4.002 603 u	C <sup>12</sup>	+12.000 000 u
	13.014 789 u		13.008 665 u

$E = ?$  The mass difference is

$$\begin{array}{r} 13.014\,789\text{ u} \\ -13.008\,665\text{ u} \\ \hline \Delta m = 0.006\,124\text{ u} \end{array}$$

$$1\text{ u} = 1.661 \times 10^{-27}\text{ kg}$$

$$\begin{aligned} \Delta m &= (0.006\,124\text{ u})(1.661 \times 10^{-27}\text{ kg/u}) \\ &= 1.017 \times 10^{-29}\text{ kg} \end{aligned}$$

$$\begin{aligned} E &= \Delta mc^2 \\ &= (1.017 \times 10^{-29}\text{ kg})(3.0 \times 10^8\text{ m/s})^2 \\ &= \mathbf{9.15 \times 10^{-13}\text{ J}} \end{aligned}$$

equal to  $1.661 \times 10^{-27}$  kg.) The mass difference is converted to kilograms and then multiplied by  $c^2$  to find the energy released in joules. This energy will appear as kinetic energy of the emerging neutron and the recoiling carbon-12 nucleus.

Although the amount of energy released in a single reaction may seem small, it is roughly a million times larger than the typical energy released (per atom) in a chemical reaction. Such changes in mass are the source of the particle

energies involved in radioactive decay and other nuclear reactions. From these ideas formulated in the early 1900s, physicists became aware of the possibility of releasing large quantities of energy in nuclear reactions.

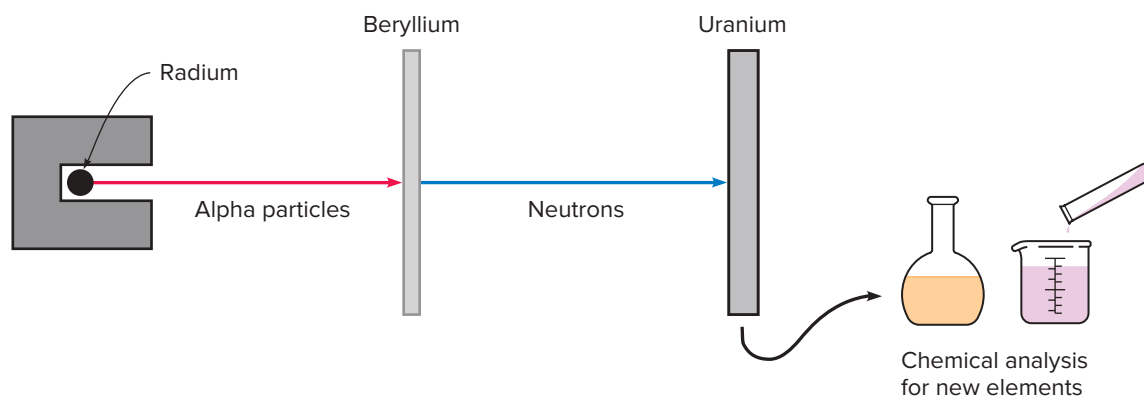
### How was nuclear fission discovered?

Before 1932, alpha particles or protons were the primary probes available for attempting to rearrange the nucleus. The discovery of the neutron immediately offered a powerful new probe, because its zero charge means it is not repelled by the positive charge of the nucleus. Because alpha particles and protons are positively charged and are repelled by the charge on the nucleus, they require high initial energies and head-on collisions to produce a reaction. The neutron, on the other hand, can slip right into the nucleus at low energies.

Italian physicist Enrico Fermi (1901–1954) was one of the first to explore the potential of the neutron for producing nuclear reactions. In a series of experiments from 1932 to 1934, he attempted to produce new heavy elements. The element with the largest mass and atomic number then known was uranium, so Fermi decided to bombard uranium samples with neutrons produced from the beryllium reaction (fig. 19.11). He then analyzed the samples to see whether he could detect elements with atomic numbers higher than 92.

At first, the results were both confusing and disappointing. Fermi and his chemist colleagues were able to predict the likely chemical properties of the elements that they were seeking by knowing what should come next in the periodic table, but attempts to isolate such elements were not successful in these early experiments. Because the expected quantities would be small and the exact chemical properties were not known, the lack of clear-cut results may not have been surprising.

Others took up the effort, and the first breakthrough in this line of research occurred in 1938, when two German scientists, Otto Hahn and Fritz Strassmann, isolated the element barium from uranium samples that had been bombarded with low-energy neutrons. This was an astonishing result that Hahn and Strassmann carefully rechecked before



**Figure 19.11** A diagram of Fermi's experiments, in which he attempted to produce new elements by bombarding uranium with neutrons.

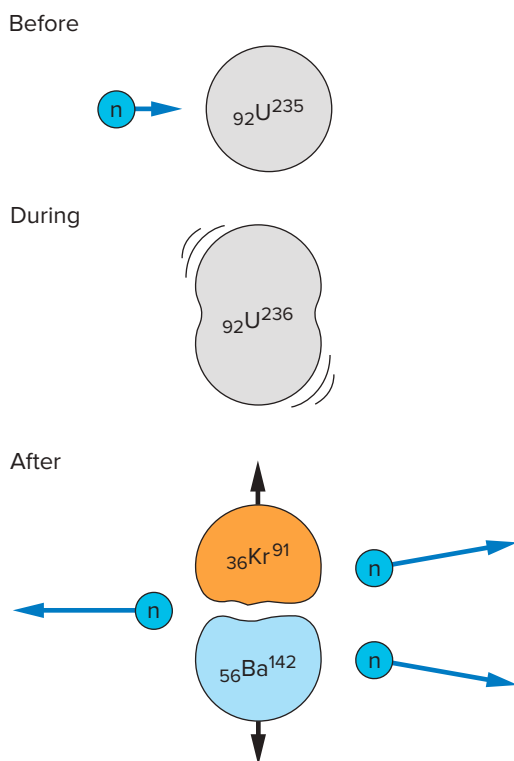
announcing their findings. The result was unexpected because barium is nowhere near uranium in the periodic table—barium has an atomic number of 56, just a little more than half that of uranium.

What kind of reaction could produce barium from uranium? Two other German scientists, then working in Denmark and Sweden because of the growing persecution of Jews in Germany, provided a possible answer.

Lise Meitner and her nephew, O. R. Frisch, speculated that the uranium nucleus might be splitting into two smaller nuclei, a process we now call **nuclear fission**. If one of these nuclei is barium with an atomic number of 56, the other should have an atomic number of 36 in order to add up to 92, the atomic number of uranium. This element happens to be krypton, a noble gas (fig. 19.12). Thus, one possible reaction equation is



This equation has been written with some extra neutrons emitted. We will indeed end up with an excess of neutrons if we split a large nucleus into two smaller ones, because the ratio of neutrons to protons gets larger and larger with increasing atomic number for the heavier elements in the periodic table (see fig. 19.5). The isotopes of barium and krypton proposed in the reaction equation also contain an excess of neutrons. Therefore, they are unstable and undergo beta decay, which means that the reaction products are radioactive.



**Figure 19.12** Barium-142 and krypton-91 are two possible fission fragments produced when a neutron is absorbed by uranium-235, causing a fission reaction.

We have jumped ahead of the story in writing uranium-235 as the isotope of uranium involved. Naturally occurring uranium is mostly uranium-238, and only 0.7% is uranium-235. Uranium-235 most readily undergoes nuclear fission, however. Low-energy neutrons are absorbed more readily by uranium-235 than by uranium-238, and fission is more likely for uranium-235 than for uranium-238 when a neutron is absorbed.

The two elements that emerge from a fission reaction are called *fission fragments*—in this case, barium and krypton. Many other elements can result, however (see example box 19.3), all having atomic numbers between 30 and 60, near the middle of the list of known elements. These fission fragments are generally radioactive because of the excess of neutrons and they make up the bulk of nuclear wastes from applications of nuclear fission.

### Example Box 19.3

#### Sample Exercise: Finding the Number of Additional Neutrons in a Radioactive Decay

In a nuclear reactor, many possible products are created with the fission of uranium-235. One possible scenario is that the fission of U-235 creates xenon-140 and strontium-94. If this reaction occurs, how many additional neutrons will be emitted in the immediate reaction?

From the periodic table, the atomic numbers for uranium, xenon, and strontium are

Uranium has 92 protons.

Xenon has 54 protons.

Strontium has 38 protons.

The reaction equation then becomes (with a question mark for the number of neutrons emitted)



Looking at the number of protons (the subscripts) on both sides of the equation,

$$0 + 92 = 54 + 38 + 0$$

There are 92 protons on each side.

Looking at the number of protons plus neutrons (the superscripts) on both sides of the equation,

$$1 + 235 = 140 + 94 + ?$$

In order for this equality to hold, there must be 2 more nucleons, either neutrons, protons, or a combination thereof. But we can't add any more protons, or the subscripts won't balance, so we will add 2 neutrons. The complete reaction equation looks like this:

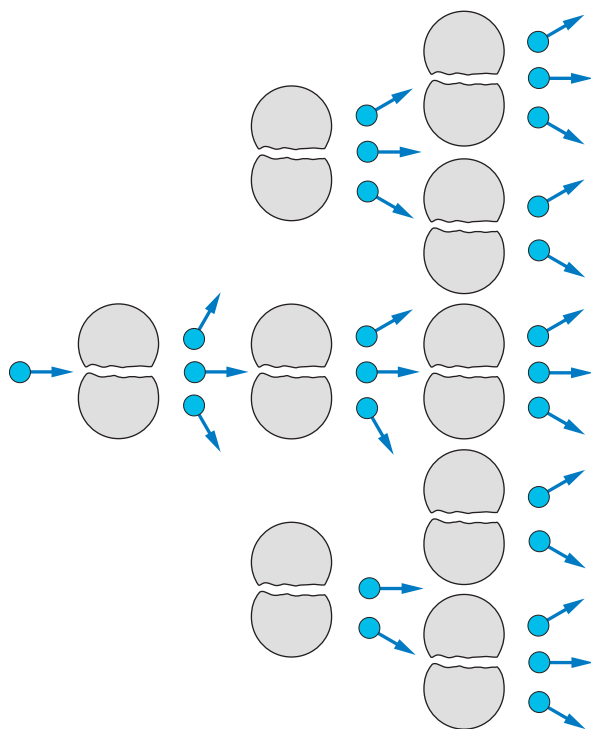




The excitement generated among scientists by these discoveries and ideas was far-reaching. In 1939, Niels Bohr, who discussed these speculations with Meitner and Frisch in Denmark, suggested that uranium-235 was the isotope involved. Bohr then traveled to the United States, where he spread the word to a growing community of nuclear scientists. Many of these scientists were refugees who had fled the precarious situation in Europe created by the beginning of World War II and the persecution of Jews in areas under Nazi control.

The excitement and concern were engendered, in part, by the immediate recognition that a **chain reaction** involving nuclear fission could be produced. A chain reaction can result because the fission reaction is initiated by a neutron, but several more neutrons are emitted in each reaction, which can cause the number of reactions to grow rapidly (fig. 19.13). A chain reaction would release enormous quantities of energy, as predicted by Einstein's mass-energy equation.

Among the European-born scientists working in the United States by 1939 were Enrico Fermi, Edward Teller, and Albert Einstein. Although Einstein was not primarily interested in nuclear physics, he was recognized throughout the world as a brilliant theoretician. The general public was familiar with his name, and for this reason, some of his colleagues prevailed on Einstein to write a letter to President Franklin D. Roosevelt suggesting the need for a crash research program to explore the military implications of nuclear fission. The Manhattan Project, begun shortly afterward, led to the development of both nuclear reactors and nuclear weapons.



**Figure 19.13** A chain reaction involving nuclear fission. Neutrons are produced in each fission of a uranium-235 nucleus, which in turn can initiate more fission reactions.

Nuclear reactions involve changes in the nucleus of atoms, which often result in one element changing into another. Radioactive decay and the reactions involved in the discoveries of the proton and neutron are examples. The amount of energy released or absorbed can be predicted from the difference in the masses of the reactants and products using Einstein's famous mass-energy equation. The discovery of the neutron provided a new probe for initiating nuclear reactions. Experiments using this probe led to the discovery of nuclear fission in the late 1930s. The possibility of a chain reaction spurred research that produced both nuclear reactors and nuclear weapons.

## 19.4 Nuclear Reactors

By 1940, the possibility of producing a chain reaction by nuclear fission was apparent to physicists in both Europe and the United States. If the fission reaction is initiated by neutrons, and each reaction produces several additional neutrons, why are chain reactions not occurring all the time in uranium samples? What conditions are necessary to produce a chain reaction? These questions demanded answers, because war was raging in Asia and Europe, and the United States and its allies feared that Germany might be developing a nuclear bomb.

### How can we achieve a chain reaction?

Understanding the conditions necessary for a chain reaction is a crucial step to knowing how both nuclear reactors and nuclear bombs work. The key is to trace what happens to the neutrons produced in the fission reaction. If enough neutrons are captured by other uranium-235 nuclei, new fissions will occur and the reaction will be sustained. If too many of the neutrons produced are absorbed by other elements or escape from the reactor or bomb without colliding with other uranium-235 nuclei, the reaction dies.

Keep in mind that natural uranium consists mainly of uranium-238 (99.3%)—only 0.7% is uranium-235. Uranium-238 also absorbs neutrons, but this does not usually result in fission. The main reason that a chain reaction does not occur in natural uranium is that the neutrons produced in one fission reaction are more likely to be absorbed by uranium-238 than by uranium-235 nuclei. One way of increasing the likelihood of a chain reaction is to increase the proportion of uranium-235 in the sample.

Unfortunately (or, fortunately, depending on your point of view), it is extremely difficult to separate uranium-235 from uranium-238. Different isotopes of the same element have identical chemical properties. (Recall that different isotopes of the same element have the same number of protons, and thus of electrons. It is the number of electrons that determines the chemical properties.) Chemical separation techniques are useless. Only the very small difference in mass between the two isotopes can be used as the basis for separation. Various techniques were tested during the war years—the most promising

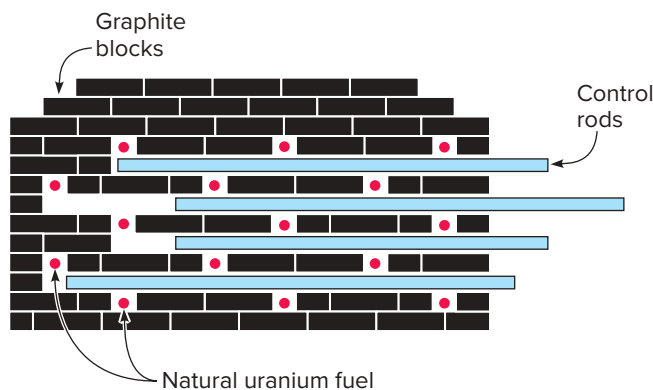
was a gas-diffusion technique tried in a plant at Oak Ridge, Tennessee. After enormous effort and expense, scientists succeeded in separating only enough uranium-235 for one bomb (just a few kilograms) by the end of the war.

A different strategy for achieving a chain reaction is used in nuclear reactors designed to run on natural uranium or on uranium only slightly enriched in uranium-235. The trick is to slow the neutrons down between fission reactions. Slow neutrons have a much greater probability of being absorbed in collisions with uranium-235 nuclei than with uranium-238 nuclei. The faster neutrons emitted in the fission reactions have almost equal probabilities of absorption when they encounter the two isotopes. Thus, if the neutrons can be slowed down before encountering additional uranium nuclei, there is a better chance of producing additional fission reactions.

Using this idea, Enrico Fermi and his coworkers at the University of Chicago achieved the first controlled chain reaction in 1942. Fermi constructed a *nuclear pile* of blocks of pure graphite interspersed with small pieces of natural uranium (fig. 19.14). Graphite is a solid form of the element carbon, which has a relatively small mass number, 12. Because carbon does not absorb neutrons readily, neutrons that collide with carbon-12 nuclei just bounce off. In each collision, the neutrons lose energy, while the carbon nuclei gain kinetic energy. The graphite slows down the neutrons without absorbing them—such a material is called a **moderator**.

Besides the moderator and the uranium fuel, one other feature is required in any reactor. Because a chain reaction can grow very rapidly under the proper conditions, we need some means of controlling the rate of reaction. **Control rods** containing a neutron-absorbing material can be inserted into or removed from the pile to maintain the desired level of reaction. In Fermi's pile, the control rods were made of cadmium, but boron is the material most commonly used now.

On December 2, 1942, Fermi and his colleagues slowly removed some of the control rods from their carefully constructed pile. By monitoring the rate of neutron flow at different points in the pile, they established that a self-sustaining chain reaction had occurred. The reactor had gone *critical*; that is, for each fission reaction, one of the new neutrons generated went on to be



**Figure 19.14** A diagram of Fermi's "pile," the first human-produced nuclear reactor. Small pieces of natural uranium were interspersed between bricks of graphite (carbon).

absorbed by another uranium-235 nucleus, producing another fission reaction. If more than one new fission reaction is produced for each initial reaction, the reactor is *supercritical*. If less than one is produced, the reactor is *subcritical*.

In starting up a reactor, we let the reactor go just slightly supercritical at first, until the desired reaction level is reached. Then, the control rods are reinserted slightly to maintain the reactor at a critical or steady-state level. Inserting the control rods further decreases the reaction level—the control rods are like the gas pedal in an automobile. Frequent adjustment of some of the control-rod positions fine-tunes the level of reaction. Other control rods are designed to be rapidly inserted to shut down the reactor.

### Why is plutonium produced in nuclear reactors?

Up to this point, we have not considered what happens when uranium-238 absorbs a neutron other than to indicate that this does not usually result in fission. Fermi's original objective of producing new elements heavier than uranium does indeed occur: A series of nuclear reactions produces plutonium, now the primary material in fission bombs.

The reactions that generate plutonium-239 from uranium-238 are summarized in table 19.3 and figure 19.15. The first step is the absorption of a neutron by a uranium-238 nucleus to produce uranium-239. Uranium-239, in turn, undergoes beta decay (half-life, 23.5 minutes) to produce neptunium-239, a new element with an atomic number of 93, one higher than uranium. Neptunium-239 also undergoes beta decay (half-life, 2.35 days), producing yet another new element with an atomic number of 94: plutonium-239. Plutonium-239 is relatively stable—its half-life is roughly 24,000 years. Like uranium-235, it readily undergoes nuclear fission when it absorbs a neutron.

Because nuclear reactors use either natural uranium or uranium only slightly enriched in uranium-235, the production of plutonium-239 is a natural by-product of the operation of a reactor. Also, because it is a different element, its chemical properties are not the same as those of uranium, and plutonium can be separated from uranium using chemical techniques. Nuclear reactors can be used to produce plutonium, a fissionable material, for nuclear weapons. A crash program was begun at Hanford, Washington, during the closing years of World War II to build nuclear reactors for precisely this purpose.

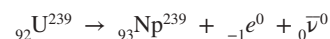
**Table 19.3**

Reactions Involved in the Production of Plutonium

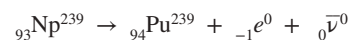
1. Neutron absorption by uranium-238

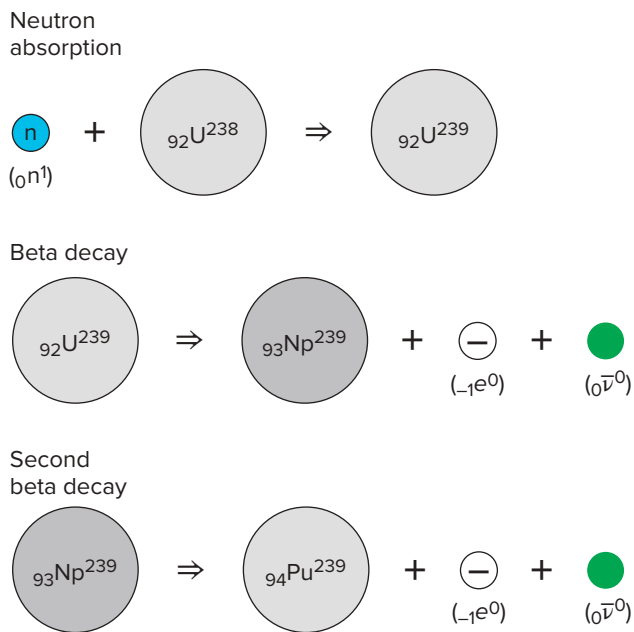


2. Beta decay of uranium-239



3. Beta decay of neptunium-239





**Figure 19.15** Absorption of a neutron by uranium-238 followed by two beta-decay reactions produces plutonium-239, which can also be used as a fission fuel.

**What are the design features of modern power reactors?**

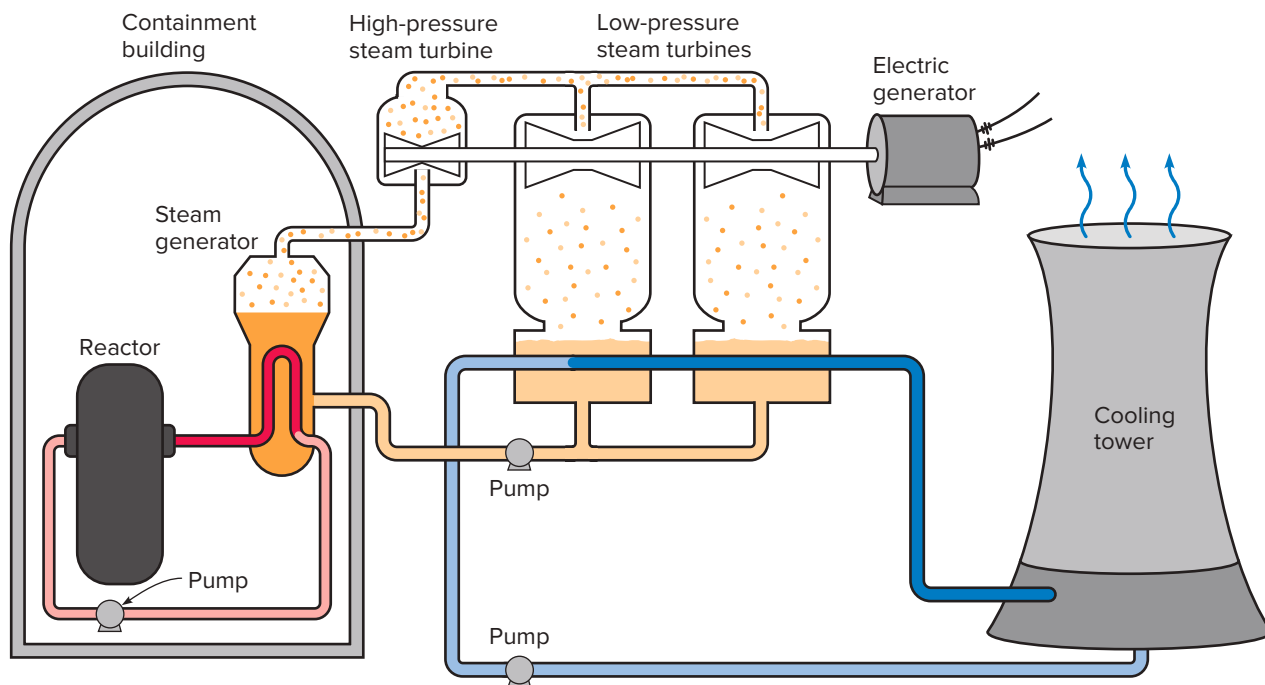
Most modern reactors designed for power production do not use graphite as the moderator—they use ordinary (*light*) water instead. Water (H<sub>2</sub>O) contains nuclei of both hydrogen (H) and oxygen (O), and the hydrogen nuclei are effective in

slowing the neutrons. Unfortunately, hydrogen also absorbs neutrons to form its heavier isotopes: deuterium (H<sup>2</sup>) and tritium (H<sup>3</sup>). *Heavy water*, made using deuterium in place of the ordinary isotope of hydrogen, absorbs neutrons less readily than light water, so it is used sometimes as a moderator.

Because the neutrons absorbed by ordinary hydrogen are removed from circulation, ordinary water is not effective as a moderator when natural uranium is the fuel. **Enrichment** of the uranium-235 concentration from the 0.7% concentration in natural uranium to approximately 3% compensates for the neutrons lost to absorption by hydrogen, however, and a chain reaction can then be achieved. Light-water reactors must use slightly enriched uranium as the fuel, but reactors using heavy water as the moderator can use natural uranium.

The advantage of using water as a moderator is that it can also serve as a **coolant**, removing heat from the reactor core. The kinetic energy of the neutrons and fission fragments released in the fission reactions show up as heat when this energy is randomized by collisions with other atoms. Any large reactor must have some means of cooling the core, or the temperature will increase to the point that some of the reactor components melt. The coolant circulates through the reactor, carrying the energy generated in the fission reactions to the steam turbines, which turn the generators to produce electric power. The turbines themselves must be cooled to operate efficiently. Heat from water used to cool the turbines is released into the atmosphere by the cooling towers. This water never passes through the reactor itself and thus is not radioactive.

Figure 19.16 is a diagram of a modern nuclear power reactor. The reactor core is contained within a thick-walled



**Figure 19.16** A diagram of a modern pressurized-water nuclear reactor. Hot water coming from the reactor is converted to steam when the pressure is reduced in the steam generators. The steam turns the turbines, which power the electric generator. The water in the loop through the cooling towers, which help cool the turbines, does not touch the radioactive water within the turbines, and so is not radioactive.

steel reactor vessel through which the coolant circulates. The reactor vessel is housed in a heavily reinforced concrete containment building designed to withstand strong pressure variations and to shield the reactor from external influences, as well as to contain radioactivity resulting from accidents. The coolant passes through steam generators, and the steam passes through the steam turbines that turn electrical generators. There is a lot of plumbing in a nuclear power plant.

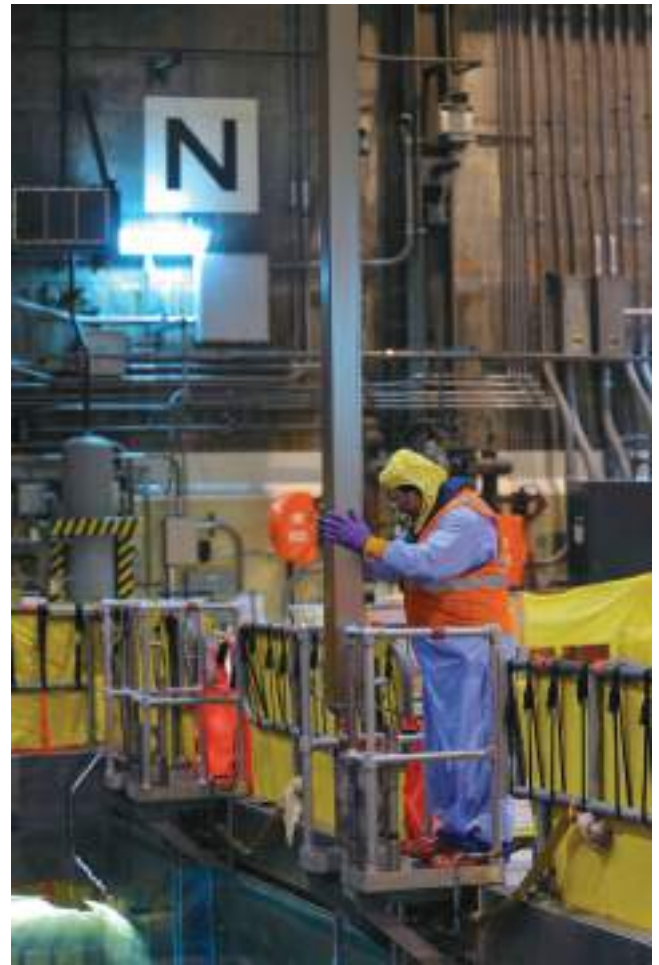
Within the plant, but outside the containment building, is a control room to oversee the pumps, control rods, and other equipment for running the reactor. Here, we also find temperature and radiation gauges and other monitoring equipment that tell the operators what is happening inside. Most reactors are designed with a lot of redundancy in safety equipment, and reactor operators are trained to deal with many contingencies. Because of the complexity of reactor operation, however, operator error is often a factor when accidents do occur, either in the initial event or in the response to a problem. Everyday phenomenon box 19.2 describes the Fukushima Daiichi reactor accident in 2011.

### Environmental issues surrounding nuclear power

Any material, such as hydrogen, that absorbs neutrons in a reactor is called a *poison*. Impurities in the moderator or fuel elements, or even the fission products themselves, can act as poisons that slow the reaction. The longer a reactor is operated, the more the poisons build up in the fuel elements and, of course, the more the uranium-235 fuel is depleted. The fuel rods must be replaced from time to time (fig. 19.17). The spent fuel rods containing uranium, plutonium, and the radioactive fission fragments must be stored or disposed of. Radioactive elements in the spent fuel rods make up most of the nuclear wastes produced by nuclear reactors.

Currently, the U.S. federal policy on waste disposal proposes burying these radioactive materials in a solid rock formation without separating the plutonium and remaining uranium from the fission fragments. This policy avoids the need for the expensive and environmentally hazardous processing involved in chemical separation. The disadvantage, however, is that it wastes fissionable material in the form of plutonium and uranium. The disposal site also must remain stable for thousands of years, because plutonium and uranium have much longer half-lives than most of the fission fragments. Plutonium-239 has a half-life of 24,000 years, but most of the fission fragments have half-lives of several years or less. They decay more rapidly and do not have to be isolated nearly as long.

When nuclear power was first introduced in the late 1950s, it was seen as a clean and inexpensive means of generating electric power. Concerns about reactor safety and waste disposal have caused many people to modify their views, but nuclear power still causes far less atmospheric pollution (while adding no greenhouse gases) than burning fossil fuels, such as coal or oil, to generate power. Disposal of nuclear wastes has become a political issue, however, and reactor safety and economic issues have also been a source of debate.



**Figure 19.17** A nuclear fuel rod assembly is lowered into the fuel rod storage pool inside the number two reactor at Exelon Corp.'s Limerick nuclear power generating station in Limerick, Pennsylvania. *Bradley C. Bower/Bloomberg/Getty Images*

The development of nuclear power in the United States is at a virtual standstill because of economic issues. The high costs and long time required for plant construction, as well as concerns about public acceptance, have made utilities back away from ordering new reactors. However, in China, parts of Europe, and many other areas of the world, the use of nuclear power continues to expand. The future of nuclear power in the United States is uncertain. The development of new, smaller reactors that are inherently stable may bring new life to this industry in the near future.

Nuclear reactors are used for many other purposes besides power production. One important application is the production of radioactive isotopes for use in nuclear medicine. These isotopes are involved in diagnostic procedures, as well as for treatment of various types of cancer. Radioactive isotopes produced in nuclear reactors are also used as tracers in industrial processes and environmental studies and for many other applications in industry and research.

## Everyday Phenomenon

## Box 19.2

**What Happened at Fukushima?**

**The Situation.** On March 11, 2011, an extremely strong earthquake (magnitude 9.0) occurred off the east coast of Japan. The earthquake was accompanied by a large tsunami with waves as high as 50 feet at points along the coast. This resulted in heavy damage along the northern Japanese coast, which included damage to nuclear reactors at the Fukushima Daiichi power plant. Meltdowns occurred at three of the six reactors, releasing radioactivity into the environment. Why did these meltdowns occur, and how could they have been avoided?



In this March 15, 2011, file photo released by Tokyo Electric Power Company, smoke rises from the badly damaged Unit 3 reactor, left, next to the Unit 4 reactor covered by an outer wall at the Fukushima Daiichi nuclear complex in Okuma, northeastern Japan. *Kyodo News/Getty Images*

**The Analysis.** The Fukushima Daiichi plant consisted of six boiling-water reactors that were put into operation at various times during the 1970s. General Electric had produced the reactors, with designs similar to some used in the United States.

When nuclear reactors are designed and constructed, engineers attempt to consider various scenarios that might result in damage to the reactors. Earthquakes are among these scenarios, as are tsunamis. The design features are intended to make the reactor withstand the strongest conceivable event. Ironically, the three reactors at Fukushima that were in operation at the time of the earthquake all shut down safely under the strong shaking of the earthquake.

The damage to the plant was caused not by the earthquake itself but by the tsunami that followed. The seawall that was supposed to protect the plant was just under 20 feet high, but the tsunami had waves as high as 40 to 50 feet, which easily overran the seawall. These waves, which began to arrive 50 minutes after the earthquake, were much higher than those planned for by the designers when the plant was built some 40 years earlier.

When a nuclear reactor shuts down and nuclear fission is stopped, heat is still generated within the reactor for several

days. Many of the decay products of nuclear fission are unstable and thus continue to release heat after fission has ceased. This means that it is necessary to continue to circulate water through the reactor to remove this decay heat.

Power is no longer being provided by the reactor after a shut-down; therefore, auxiliary power must be provided to run pumps to cool the reactor. Because we cannot count on electric power lines in an emergency, diesel generators are located at plant site to run the pumps. These generators were available at Fukushima Daiichi, but they were located in the basement of the reactor building, which was not flood-proof.

When the plant was inundated by the tsunami, the generators were flooded and failed to operate. The reactors then began to overheat, which has two important consequences. At around 500°C, a reaction between steam and the zirconium cladding of the fuel rods causes the release of hydrogen gas, which is explosive. At still higher temperatures, the fuel rods melt and collapse into the bottom of the reactor vessel. Both of these effects occurred at Fukushima in the three reactors that were running at the time of the earthquake.

The reactor operators were criticized for not quickly using seawater to cool the reactors by using external pumps available on fire engines. The operators hesitated because they knew that the corrosive effects of salt water would have destroyed the reactors. Eventually, seawater was used to cool the reactors, but by this time hydrogen explosions had already compromised the containment buildings surrounding the reactors. If seawater had been used earlier, the hydrogen explosions and subsequent meltdowns may have been prevented. While the reactors still would have been destroyed, much less radiation would have been released to the environment.

The impact of the nuclear accident at Fukushima was to destroy three of the six reactors at the plant and severely damage a fourth due to hydrogen explosions. In addition, radiation releases to the water tables and surrounding countryside will leave a considerable area uninhabitable for many years. In 2018 the Japanese government reported that one reactor worker had died of cancer, the only death directly attributable to the accident. It does not appear that there will be increased risk of cancer in the surrounding population due to radiation effects. These minimal health effects can be attributed to the quick evacuation of people in the area and careful monitoring and management of the exposure to the reactor workers.

The accident could have been avoided if the power company, Tokyo Electric Power Company, and regulating agencies had reacted proactively to more recent estimates of possible tsunami heights. Current standards in Japan and elsewhere call for more careful placement and protection of the diesel generators needed for cooling the reactors in the event of an emergency. These standards were recommended but not required for older reactors. This, of course, will change in light of the Fukushima accident.

To sustain a chain reaction, on average at least one neutron released in each fission must be absorbed by a uranium-235 nucleus to initiate a new fission reaction. If more than one neutron is absorbed, the reaction is supercritical and will grow rapidly. If less than one is absorbed, the reaction is subcritical and will die. In a nuclear reactor, the neutrons are slowed down by the moderator, increasing their likelihood of being absorbed by other uranium-235 nuclei. Control rods absorb neutrons and permit the rate of reaction to be adjusted. Fermi's original reactor used graphite as the moderator, but modern reactors use water, which also serves as a coolant. Fission fragments and plutonium build up in the fuel rods, which must eventually be removed from the reactor, becoming nuclear wastes.

### Debatable Issue

France gets more than 75% of its power from nuclear energy and claims a substantial level of energy independence and almost the lowest-cost electricity in Europe. It also has an extremely low level of CO<sub>2</sub> emissions per capita from electricity generation. Why is nuclear power not used more extensively in other European countries or in the United States?

## 19.5 Nuclear Weapons and Nuclear Fusion

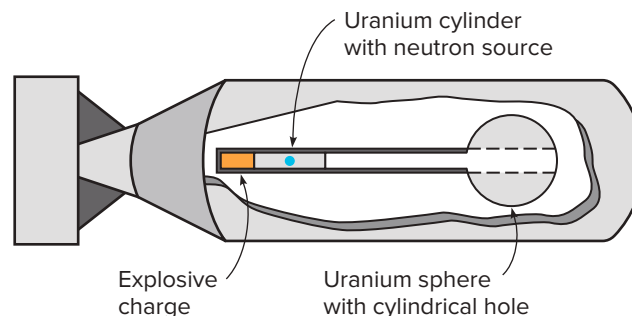
In a nuclear reactor, the objective is to release energy from fission reactions in a controlled manner, never letting the chain reaction get out of hand. In a bomb, on the other hand, the objective is to release energy very quickly—a supercritical chain reaction is what is sought. How can this state be achieved? What conditions are necessary for a nuclear explosion? What is the difference between fission weapons and weapons that use *nuclear fusion*?

### What is critical mass?

The initial approach to producing nuclear weapons involved separating uranium-235 from uranium-238 to produce a highly enriched sample of uranium-235. If most of the uranium-238 is removed, neutrons emitted in the initial fission reactions will be much more likely to encounter other uranium-235 nuclei, and a rapidly increasing chain reaction should result. The size of the uranium mass is also important: If it is too small, neutrons will escape through its surface before they encounter other uranium-235 nuclei.

A **critical mass** of uranium-235 is a mass just large enough for a self-sustaining chain reaction. For a mass smaller than the critical mass, too many of the neutrons generated in the initial fission reactions escape through the surface of the uranium without encountering other nuclei.

For a mass larger than the critical mass, more than one of the neutrons produced in each fission reaction will be



**Figure 19.18** The gun concept used in the Little Boy uranium bomb design. A subcritical-size cylinder of uranium-235 is fired into the hole in a subcritical sphere of uranium-235 to make a supercritical mass of uranium-235.

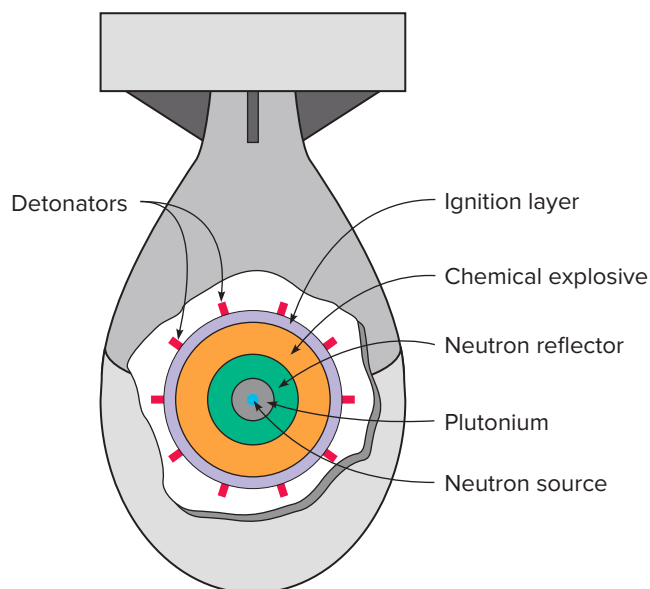
absorbed by other uranium-235 nuclei and produce additional fission reactions. The chain reaction will grow very rapidly, because the time between reactions is very short. This is the *supercritical* state necessary for an explosion.

How can we create a supercritical mass without having it blow apart prematurely? The energy released in a fission chain reaction causes rapid heating and expansion. If a supercritical mass were built up slowly from subcritical pieces, the mass would begin to come apart as soon as it became supercritical. The bomb would fizzle. One approach to solving this problem is to bring two subcritical pieces of almost-pure uranium-235 together rapidly to produce a strongly supercritical mass. A gun design, as in figure 19.18, was developed for the first uranium bomb. A subcritical cylinder of uranium-235 is fired into a subcritical sphere of the same material containing a cylindrical hole, thus quickly assembling a supercritical mass. A neutron source must also be present to initiate the reaction.

The major problem in producing a bomb like this is the extreme difficulty of separating uranium-235 from the much more abundant isotope, uranium-238. The gas-diffusion plants at Oak Ridge, Tennessee, were able to produce only enough pure uranium-235 for one bomb during the war years. Building a nuclear arsenal at that rate would have been slow and expensive. It became apparent that plutonium-239 might be a better nuclear fuel than uranium-235.

### How are plutonium bombs designed?

Plutonium-239 is a natural by-product of nuclear reactors that use uranium for fuel. As noted in section 19.4, the reactors built at Hanford, Washington, during World War II were designed to produce plutonium for weapons. The fission reaction of plutonium-239 is different from that of uranium-235, however, so the gun design used for the uranium bomb will not work with plutonium. Plutonium-239 absorbs fast neutrons much more readily than uranium-235, which causes the chain reaction to grow even more swiftly than for uranium, and two subcritical pieces cannot be brought together quickly enough to avoid the fizzle produced by premature disintegration.



**Figure 19.19** The so-called Fat Man plutonium bomb used chemical explosives arranged around a subcritical mass of plutonium-239. When imploded by the explosives, the increased density makes this mass supercritical.

The design used for plutonium bombs relies on *implosion*: Explosives arranged around a subcritical mass of plutonium and fired together create a tremendous inward pressure on the plutonium. This pressure increases the density of the plutonium sample enough to make the mass supercritical (fig. 19.19). The same number of atoms are now confined in a smaller volume, increasing the probability of absorption of neutrons by other plutonium nuclei.

By the end of World War II, enough weapons-grade material had been assembled to produce just three nuclear bombs. Two of them were plutonium bombs, dubbed *Fat Men* because of their shape. The third bomb was a uranium bomb, called *Little Boy* because of its slimness (fig. 19.18). In a historic test, one of the plutonium bombs was exploded at White Sands, New Mexico, in the summer of 1945, producing the first of the immense mushroom clouds of nuclear explosions. Shortly thereafter, the other two bombs were dropped on the cities of Hiroshima and Nagasaki in Japan.

During the war years, the effort to build and test nuclear bombs was seen as a race with Nazi Germany, where the fission reaction had originally been discovered. Many of the scientists working on the Manhattan Project were European refugees. The possibility that Germany might acquire the bomb first was horrifying. As the war was winding down, and the success of the bomb-building effort was approaching, it became evident that Germany no longer had the resources to produce a nuclear bomb. A debate began among the scientists on the project about how to use the bomb. Many scientists favored a demonstration of the bomb's effects without actually using one on military targets.

A demonstration involved serious problems, however, especially because there were only two bombs available after

the test of the plutonium bomb. One of these, the uranium bomb, could not be tested beforehand, because only one had been built. The decision to drop the bombs on Japan was made by the top military authorities, including President Harry S. Truman. Although still controversial, that decision probably hastened the end of the war, avoiding the need for a costly invasion of Japan.

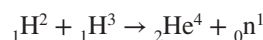
After the war, weapons production went on, as the Hanford reactors continued to generate more plutonium. Soon, Russia had the ability to manufacture fission bombs, and the pressure increased to proceed to the next step in the race, the development of the hydrogen bomb, which was first successfully tested in 1952. A hydrogen bomb involves nuclear fusion rather than fission.

### What is the fusion reaction?

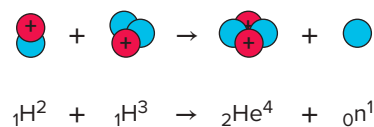
What happens in a hydrogen bomb? **Nuclear fusion** is another kind of nuclear reaction that releases large quantities of energy. Fusion is the energy source of the sun and other stars, as well as of *thermonuclear* bombs. How does nuclear fusion differ from fission, and how can we generate a chain reaction involving fusion?

Nuclear fusion combines very small nuclei to form somewhat larger nuclei. In a sense, it is the opposite of nuclear fission, the splitting of large nuclei into smaller fission fragments. The fuel for fusion consists of very light elements, usually isotopes of hydrogen, helium, and lithium. (Lithium has an atomic number of 3.) The end product is often the particularly stable nucleus, helium-4, which we have already encountered as the alpha particle.

As long as the mass of the helium-4 nucleus and other reaction products is slightly less than the sum of the masses of the isotopes combining to produce the reaction, this mass difference will show up as kinetic energy, as predicted by Einstein's formula  $E = mc^2$ . One possible reaction is the combination of two isotopes of hydrogen—deuterium ( ${}^2_1\text{H}$ ) and tritium ( ${}^3_1\text{H}$ )—to form helium-4 plus a neutron:



As shown in figure 19.20, the sum of the masses of the two particles on the right side of this equation is less than



Masses			
${}_1\text{H}^2$	2.014 102 u	${}_2\text{He}^4$	4.002 603 u
${}_1\text{H}^3$	3.016 050 u	${}_0\text{n}^1$	1.008 665 u
	<hr/>		<hr/>
	5.030 152 u		5.011 268 u

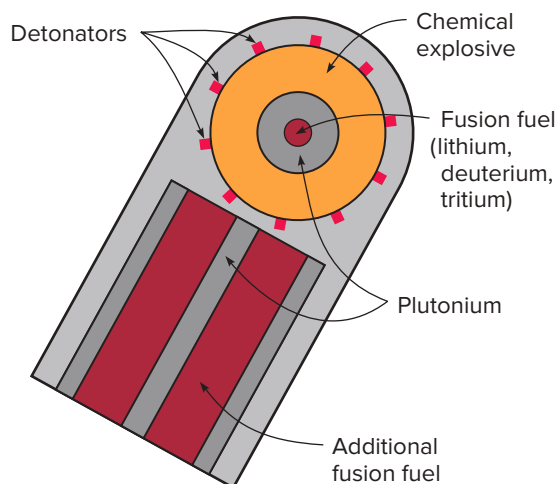
**Figure 19.20** A deuterium nucleus and a tritium nucleus combine to form a helium-4 nucleus and a neutron. The difference in the masses is converted to the kinetic energy of the emerging particles.

the sum of the masses of the two particles on the left side. The total kinetic energy of the alpha particle and the neutron will be greater than the kinetic energy of the initial two particles.

What makes this reaction so difficult to produce is that all the nuclei are positively charged and repel one another. Large initial kinetic energies are needed to overcome the repulsive electrostatic force, so that the two nuclei can combine. One way of assuring large kinetic energies is to heat the reactants to a very high temperature. High densities of the reacting isotopes are also necessary to increase the probability of the reactions occurring. The reactants must be confined in a very small space at a very high temperature, two requirements hard to achieve simultaneously.

The chain reaction that results under these conditions is called a *thermal chain reaction*. Very high temperatures are needed to initiate the reaction, and the energy released in the reaction raises the temperature even more. The temperatures required for nuclear thermal chain reactions are a million degrees Celsius or more. Chemical explosions are also thermal chain reactions, but the temperatures required for chemical reactions are much lower and more easily attainable.

The easiest way to get both the high temperatures and the high densities required for a fusion chain reaction is to explode a fission bomb to initiate the fusion reaction. The high temperature produced by the fission bomb creates the high kinetic energies necessary for fusion. The fission explosion also compresses the fusion fuel momentarily—the time is very short but still long enough for considerable additional energy to be released from fusion reactions (fig. 19.21). Basically, this is how a hydrogen bomb (also called a thermonuclear bomb) works.



**Figure 19.21** A fission bomb is exploded around the fusion fuel to produce the high temperatures and density required for a fusion chain reaction in a thermonuclear bomb.

Hydrogen bombs can be made in various sizes, unlike fission bombs, which are restricted to a size dependent on the critical mass of the fissionable material. Much larger energy yields are possible with fusion bombs than with pure fission bombs. Even though the energy released per reaction is smaller for fusion reactions than for the typical fission reaction, pound for pound the fusion reactions pack more wallop, because the fusion fuels consist of very light elements. Hydrogen bombs can be made with an explosive power equivalent to 20 million tons of TNT or more. (Tons of TNT is the standard basis for comparison in quoting bomb yields.) Both fission and fusion bombs now make up the arsenals of the nuclear powers.

### Can we generate power from controlled fusion?

Producing fusion reactions for a commercial power source has not yet been accomplished. Confining the fuel at very high temperatures in a very small space for a long enough time to release a significant amount of energy presents extreme difficulties. Because any solid will melt at temperatures well below those required for fusion reactions, magnetic fields or some other scheme must be used to confine the fuel (fig. 19.22). Another approach involves bombarding a small pellet of fusion fuel with laser beams (or particle beams) from several directions to both heat and compress the pellet.

Projections made in the 1970s that we would have working fusion reactors by the 1990s were highly optimistic. It now seems that this goal may not be achieved until well into the twenty-first century. We cannot be completely confident that an economically feasible reactor will ever be built, but we have already invested heavily in the effort, and someday the goal should be reached. Experimental reactors, such as the Tokamak (fig. 19.22), have generated energy from



**Figure 19.22** Scientists working in a tokamak reactor, Oxfordshire, England, Culham Centre.  
Monty Rakusen/Cultura/Getty Images



fusion, but they have not reached the break-even point, where as much energy is released as is required to initiate the reaction. Yields must be improved to make the process commercially viable.

Considerable excitement was generated a number of years ago (1988–1989) when scientists working in Utah claimed to have achieved *cold fusion* in a cell that did not require extraordinary temperatures or densities. Their cell involved a palladium electrode immersed in a beaker containing heavy water (in which deuterium replaces the ordinary isotope of hydrogen). By passing a current through the cell, deuterium atoms are drawn into the spaces between the atoms in the palladium electrode. The Utah group claimed to have observed excess heat (presumed to be produced by fusion) that could not be explained by other chemical or physical processes occurring in the cell.

Although occasional fusion reactions occur under these circumstances, not enough fusion results to produce usable quantities of energy. If it were possible, though, the commercial potential would be enormous. The claims of the Utah group piqued a great deal of publicity and public interest. Many workers have attempted to reproduce their experiments, but so far the results have been disappointing. Most physicists do not believe that usable fusion energy is likely to come from cold fusion.

We do not yet know the best approach to achieving energy from fusion. Work continues on magnetic containment and on the particle-beam and laser-beam techniques. A few scientists are still exploring cold fusion. If a breakthrough occurs in the near future, some of today's students of science and engineering will be involved in a new expansion of applications of nuclear power.

To produce a nuclear explosion using fission, a supercritical mass of either uranium-235 or plutonium-239 must be assembled quickly from subcritical components. In a uranium bomb, firing a subcritical cylinder of uranium into a subcritical sphere with a cylindrical hole achieves critical mass. In a plutonium bomb, this is achieved by firing chemical explosives arranged around a subcritical sphere of plutonium, compressing it to a supercritical condition. Nuclear fusion releases energy by combining small nuclei to form larger nuclei. Fusion is the energy source of the sun and of hydrogen or thermonuclear bombs. Attempts to produce power from controlled fusion are not yet commercially viable, but research on this problem may someday reach that goal.

## Summary

We have traced how identifying the nuclear constituents—the proton and the neutron—led to an understanding of isotopes and of what happens in radioactive decay. The discovery of the neutron also gave us a new tool for probing and modifying nuclei, which led to the discovery of nuclear fission. Nuclear fission and fusion are nuclear reactions capable of releasing large amounts of energy.

**1 The structure of the nucleus.** Experiments in which alpha particles were scattered from various nuclei led to the discovery of both the proton and the neutron as constituents of the nucleus. The number of protons in a nucleus is the atomic number of an element. The total number of protons and neutrons (nucleons) is the mass number of a given isotope. The same element can have isotopes of different masses.

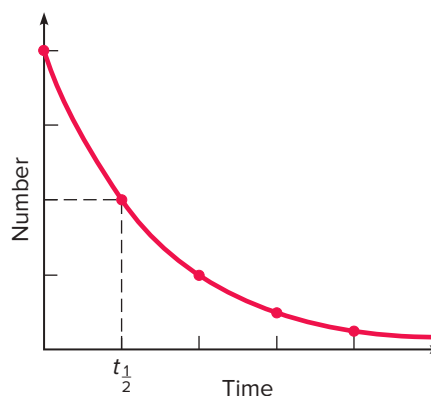
Lithium-7 ( ${}^7_3\text{Li}$ )



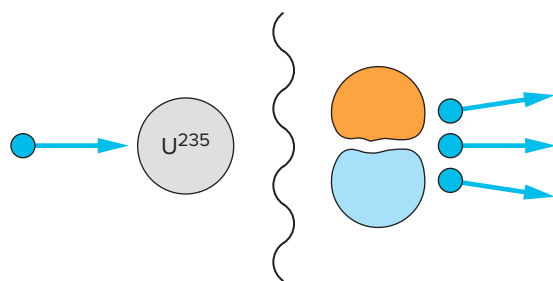
3 protons  
4 neutrons  
7 nucleons

**2 Radioactive decay.** Radioactive decay is a spontaneous nuclear reaction in which a particle or gamma ray is emitted and the structure of the nucleus changes. One element is transformed into another in alpha or beta decay. The half-life is the time

required for half of the original number of radioactive nuclei to undergo decay.

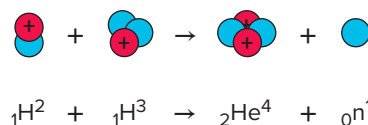


**3 Nuclear reactions and nuclear fission.** In any nuclear reaction, one element may change into another, but the total charge number (atomic number) and mass number (nucleon number) are conserved. Fission was discovered by bombarding uranium samples with neutrons, which leads to the splitting of the uranium-235 nucleus into fission fragments and the emission of additional neutrons.



**4 Nuclear reactors.** Nuclear reactors generate energy by allowing a controlled nuclear-fission chain reaction to take place. The moderator slows down the neutrons to increase the probability of absorption by uranium-235, the fissionable isotope of uranium. Control rods absorb neutrons to control the reaction level, and the coolant carries off the energy generated. Spent fuel rods contain radioactive fission fragments as well as uranium and plutonium.

**5 Nuclear weapons and nuclear fusion.** Bombs can be built from either uranium or plutonium. Plutonium is produced in reactors when neutrons are absorbed by uranium-238. In nuclear fusion, small nuclei combine to form larger nuclei, which also can release energy. Hydrogen bombs use a fission bomb to trigger the high temperatures and densities needed for fusion.



Try the practice problems in Connect. They will give you some additional examples of how to determine the different products in numerous nuclear reactions.

## Key Terms

Proton, 410	Antiparticle, 413	Moderator, 421
Neutron, 410	Ionized, 414	Control rods, 421
Isotope, 412	Half-life, 415	Enrichment, 422
Atomic number, 412	Exponential decay, 415	Coolant, 422
Radioactive decay, 412	Nuclear reaction, 417	Critical mass, 425
Nucleon, 412	Nuclear fission, 419	Nuclear fusion, 426
Mass number, 412	Chain reaction, 420	

## Conceptual Questions

\* = more open-ended questions, requiring lengthier responses, suitable for group discussion

Q = sample responses are available in appendix D

Q = sample responses are available in Connect

- Q1. In 1919, Rutherford bombarded a sample of nitrogen gas with a beam of alpha particles.
- In addition to alpha particles, what other particle emerged from the nitrogen gas in this experiment?
  - What conclusion did Rutherford draw from this experiment? Explain.
- Q2. When beryllium is bombarded with alpha particles, a very penetrating radiation is emitted from the beryllium sample. Does this radiation consist of X-rays? Explain.
- Q3. Is it possible for two atoms of the same chemical element to have different masses? Explain.
- Q4. Is it possible for neutral atoms of the same chemical element to have different chemical properties? Explain.
- Q5. Which number, the mass number or the atomic number, determines the chemical properties of an element? Explain.
- Q6. Why is the atomic mass of chlorine, as determined from chemical experiments, not a whole-number multiple of the atomic mass of hydrogen? Explain.
- \*Q7. In a nuclear reaction, can the total mass of the products of the reaction be less than the total mass of the reactants? Explain.
- Q8. In alpha decay, do we expect the atomic number of the daughter nucleus to be equal to, greater than, or less than the atomic number of the isotope undergoing decay? Explain.
- Q9. In beta decay, do we expect the atomic number of the daughter nucleus to be equal to, greater than, or less than the atomic number of the isotope undergoing decay? Explain.
- Q10. What is a neutrino, and why did scientists believe in its existence long before it was ever detected? Explain.
- Q11. In gamma decay, do we expect the atomic number of the daughter nucleus to be equal to, greater than, or less than the atomic number of the decaying isotope? Explain.
- Q12. What type of radioactive particles are used in smoke detectors and why? Explain. (See everyday phenomenon box 19.1.)
- Q13. When smoke particles are present in the air, the electric current to the alarm in the smoke detector decreases for two reasons. What are they? Explain. (See everyday phenomenon box 19.1.)
- Q14. Does the battery in a smoke alarm create the charge on the plates or the charge on the ions? Explain. (See everyday phenomenon box 19.1.)
- Q15. Do all radioactive substances decay at the same rate? Explain.

- Q16. In a time equal to two half-lives of a radioactive isotope, would you expect all of that isotope to have decayed? Explain.
- Q17. In chemical reactions, the individual elements present in the reactants are the same as in the products of the reaction. Is this also true in a nuclear reaction? Explain.
- Q18. Chemical reactions and nuclear reactions can both release energy. On average, would you expect the energy released per unit of mass in a chemical reaction to be greater than, equal to, or less than what is released in a nuclear reaction? Explain.
- \*Q19. Why do we expect fission fragments to have higher neutron numbers than stable isotopes of the same element and, therefore, expect them to be radioactive? Explain.
- Q20. Suppose you light a match to a mixture of oxygen and hydrogen, which then reacts explosively to form water. Is this a chemical reaction or a nuclear reaction? Explain.
- Q21. The most common isotope of uranium is uranium-238. Is this the isotope that is most likely to undergo fission? Explain.
- Q22. What property of the fission reaction leads to the possibility of a chain reaction? Explain.
- \*Q23. What is the function of the moderator in a nuclear reactor? Explain why the moderator is needed to obtain a chain reaction using natural uranium.
- Q24. Do the control rods in a nuclear reactor absorb or emit neutrons? Explain.
- Q25. If you wanted to slow down the chain reaction in a nuclear reactor, would you remove or insert the control rods? Explain.
- \*Q26. Will a reactor that uses ordinary water as the moderator be able to operate using unenriched uranium as a fuel? Explain.
- Q27. If a reactor goes subcritical, will the chain reaction speed up? Explain.
- \*Q28. If plutonium and uranium are removed from the spent fuel of a nuclear reactor, will the remaining nuclear wastes need to be stored for thousands of years before they become non-radioactive? Explain.
- Q29. In Fermi's original experiments in which he bombarded uranium samples with neutrons, he was trying to produce new elements heavier than uranium. Is it possible to do so? Explain.
- Q30. Was the damage to the reactors at Fukushima caused directly by the shaking of the strong earthquake off the coast of Japan? Explain. (See everyday phenomenon box 19.2.)
- Q31. Given that nuclear power plants are designed to produce electric power, why are diesel generators needed at a nuclear power plant? Explain. (See everyday phenomenon box 19.2.)
- Q32. Several explosions occurred during the Fukushima accident. Were these explosions caused by nuclear-fission chain reactions, or was some other effect involved? Explain. (See everyday phenomenon box 19.2.)
- Q33. What was the purpose of the nuclear reactors built at Hanford, Washington, during World War II? Explain.
- Q34. How does nuclear fusion differ from nuclear fission? Explain.
- Q35. Is nuclear fission the main process involved in the energy generated in the sun? Explain.
- Q36. Do we currently have commercial nuclear reactors that use nuclear fusion as their energy source? Explain.
- \*Q37. Which can produce larger yields of energy, a fission weapon or a fusion weapon? Explain.

## Exercises

- E1. Argon has an atomic number of 18 and an atomic weight of approximately 40. How many neutrons would you expect to find in the nucleus of the most common isotope of argon?
- E2.  ${}_{53}^{131}\text{I}$  (iodine-131) is widely used in diagnosing and treating thyroid cancer.
- How many protons are in the nucleus of this isotope?
  - How many neutrons are in the nucleus of this isotope?
- E3. A certain isotope has 22 protons and 26 neutrons in its nucleus. Identify the element involved and write its symbol in the standard notation, including the atomic and mass numbers.
- E4. The radioisotope iridium-192 is used in gamma radiography to locate flaws in metal components in industry. It has an atomic number of 77. How many protons and how many neutrons are present in the nucleus of this isotope?
- E5. Radon-222 undergoes alpha decay. Complete the reaction equation for this decay and identify the daughter nucleus.
- $${}_{86}^{\text{Rn}}222 \rightarrow ? + \alpha$$
- E6. Lead-214 undergoes negative beta decay. Complete the reaction equation and identify the daughter nucleus.
- $${}_{82}^{\text{Pb}}214 \rightarrow ? + {}_{-1}e^0 + {}_0\nu^0$$
- E7. Oxygen-15 is a radioactive isotope of oxygen that undergoes positive beta decay in which a positive electron (or positron) is emitted. Complete the reaction equation and identify the daughter nucleus.
- $${}_{8}^{\text{O}}15 \rightarrow ? + {}_{+1}e^0 + {}_0\bar{\nu}^0$$
- E8. Suppose we have 102,400 atoms of a radioactive element with a half-life of 12 minutes.
- How many atoms of that element are likely to remain after 48 minutes?
  - How many atoms of the daughter element are likely to be created in that 48 minutes?
  - How many atoms of the original radioactive element are likely to remain after 1 hour and 24 minutes?
- E9. When we measure the rate of radioactivity of a given isotope 28 days after making an initial measurement, we discover that the rate has dropped to one-sixteenth of its initial value. What is the half-life of this isotope?
- E10. How many half-lives must go by for the radioactivity of a given isotope to drop to
- One-eighth (1/8) of its original value?
  - One-thirty-second (1/32) of its original value?
- E11. Suppose we discover that one of the fission fragments for a given fission reaction of uranium-235 is barium-144 and that two neutrons are emitted in this reaction. Complete the reaction equation and identify the other fission fragment.
- $${}_0^1n^1 + {}_{92}^{\text{U}}235 \rightarrow ? + {}_{56}^{\text{Ba}}144 + 2{}_0^1n^1$$
- E12. Suppose two deuterium nuclei ( ${}_1\text{H}^2$ ) combine in a fusion reaction in which a neutron is emitted. Complete the reaction equation and identify the resulting nucleus.
- $${}_1^2\text{H} + {}_1^2\text{H} \rightarrow ? + {}_0^1n^1$$

## Synthesis Problems

- SP1. Using the periodic table found in appendix E, we can investigate how the number of neutrons increases compared to the number of protons as the atomic number increases. By rounding the atomic weight to the nearest whole number, we can estimate the total number of nucleons (neutrons and protons) in the most common isotope of each element.
- What are the neutron and proton numbers for the common isotopes of carbon (C), nitrogen (N), and oxygen (O)?
  - What is the ratio of neutron number to proton number for these three elements? (Ratio =  $N_n/N_p$ )
  - Taking three elements near the middle of the table—silver (Ag), cadmium (Cd), and indium (In)—find the neutron and proton numbers using the method employed in part a.
  - Compute the ratio of neutron number to proton number for the elements in part c and find the average ratio.
  - Repeat the process of parts a and b for thorium (Th), protactinium (Pa), and uranium (U).
  - Compare the ratios of parts b, d, and e. Can you see why there are extra neutrons when uranium or thorium undergoes fission?
- SP2. Uranium and thorium are the radioactive elements found in some abundance in the Earth's crust. As each isotope of these elements decays, new radioactive elements are created that have much shorter half-lives than uranium or thorium. A series of alpha and beta decays occurs that leads to a stable isotope of lead (Pb). One such series begins with the isotope thorium-232 and proceeds through these elements:
- $$\text{Th} \rightarrow \text{Ra} \rightarrow \text{Ac} \rightarrow \text{Th} \rightarrow \text{Ra} \rightarrow \text{Rn} \rightarrow \text{Po} \rightarrow \text{Pb} \rightarrow \text{Bi} \rightarrow \text{Po} \rightarrow \text{Pb}$$
- Using the periodic table, find the atomic numbers for all of these elements.
  - Identify which of the reactions in this series involve alpha decay and which involve beta decay. (The change in atomic number provides all the information you need.)
- Write the reaction equations for the first three decays in this series.
  - Fill in the mass numbers for all of the isotopes in this series.
- SP3. Consider the fusion reaction  ${}_1\text{H}^2 + {}_1\text{H}^2 \rightarrow {}_2\text{He}^3 + {}_0\text{n}^1$ . From tables of nuclear masses, we can find the masses for the reactants and products in this reaction:
- $$\begin{array}{l} \text{H}^2 \text{ 2.014 102 u} \\ \text{He}^3 \text{ 3.016 029 u} \\ \text{n} \text{ 1.008 665 u} \end{array}$$
- Find the mass difference  $\Delta m$  between the reactants and the products for this reaction.
  - Following the procedure used in example box 19.2, convert this mass difference to energy units.
  - Is energy released in this reaction, and if so, where does it go? Explain.
- SP4. Nuclear power has been a constant source of controversy. Although the use of nuclear power has grown during this time, we still get over half of our electric power by burning fossil fuels. The environmental and economic impacts differ for these energy sources.
- Burning fossil fuels produces carbon dioxide as a natural by-product. Carbon dioxide is one of the gases that contributes to the greenhouse effect and global warming, as discussed in chapter 10. Is this a problem with nuclear power also? Explain.
  - What environmental problems associated with nuclear power are not present in the burning of fossil fuels? Explain.
  - What environmental problems associated with fossil fuels are not present in the use of nuclear power? Explain.
  - On balance, which of these power sources would you choose to develop further if other alternatives were not available? Explain. (Reasonable people may differ here!)

## Home Experiments and Observations

- HE1. The concept of half-life, and the associated exponential decay curve, can be made more vivid by using piles of pennies (or other stackable objects) to represent atoms.
- Collect as many pennies as you can find on dresser tops and from coin purses. Fifty to one hundred should suffice.
  - Divide your pile into two equal stacks, placed side by side. The left pile represents the original number of atoms.
  - Divide the right pile in half. Place one of the resulting stacks next to the original left stack. This represents the number of atoms remaining after one half-life has passed.
  - Continue this process, always dividing the remaining right stack in half and placing the stack obtained from division next to those stacks already accumulated. The resulting row of stacks, each one smaller than the preceding one, forms an exponential decay curve. How many half-lives do you obtain before you are down to a one-penny stack?
- HE2. The concept of a chain reaction can be made more vivid by using the same piles of pennies (or other objects) you used in HE1. Gather about \$3.00 worth of pennies. Each pile will represent the number of neutrons produced as the chain reaction continues.
- Assume each fission creates 3 neutrons, as shown in figure 19.13. On the first pile, put one penny to indicate the neutron that initiated the fission.
  - On the next pile, put  $3 \times 1$ , or 3, pennies, to indicate the 3 neutrons created in the fission.
  - On the next pile, put  $3 \times 3$ , or 9, pennies, given that each of the 3 neutrons produced in the first reaction will create 3 more neutrons in the next set of reactions.
  - How many pennies do you need in the next pile? And in subsequent piles?
  - How many piles do you need to have more than 100 pennies in a pile?
  - How many piles would you need to have more than 1000 pennies per pile? (Follow the pattern and calculate this, because it is unlikely you have found that many pennies.)



# UNIT 6

## Relativity and Beyond

**T**hroughout this book, we have tried to build your understanding of physics concepts by stressing their origin in, and application to, everyday phenomena—things that happen around us all the time. Certainly, we have strayed at times from everyday events, particularly in discussing the structure of the atom and its nucleus. These ideas have their origins in simple experiments, however, and they have many applications to familiar technology.

Some of the most fascinating ideas of modern physics are a bit more difficult to relate to everyday experience—for example, the theories of special and general relativity developed by Albert Einstein in the early years of the twentieth century. Relativity is fun to explore, though, because it challenges us to rethink basic concepts such as space and time. Einstein's ideas can stretch your mind.

The development of quantum mechanics and its application to nuclear physics have also led to areas of research far removed from everyday experience. New particles have been discovered in what is often called *high-energy physics*. We never see these particles, and their properties carry unusual names, like strangeness and charm, but they, too, are important to deciphering the fundamental nature of the universe. Together with relativity, the quantum theories of high-energy physics take us back to the beginning of time and the Big Bang.

The final two chapters of this book briefly explore the theories of relativity (chapter 20) and recent developments



*Source: NASA, Jayanne English (University of Manitoba), Sally Hunsberger (Pennsylvania State University), Zolt Levay (Space Telescope Science Institute), Sarah Gallagher (Pennsylvania State University), and Jane Charlton*

in modern physics (chapter 21). Chapter 21 includes discussions of the particle zoo and cosmology, as well as developments in condensed-matter physics that brought about the revolution in microelectronics and computers.

The discoveries of fission and fusion occurred over 90 years ago, during the 1930s and 1940s. What has happened since these breakthroughs? What can we expect to hear from physics in the future? Chapters 20 and 21 may serve as a preview.



# CHAPTER 20

Source: NASA

## Relativity

### Chapter Overview

After reexamining how relative motion is handled in classical physics, we introduce Einstein's postulates of special relativity and explore their consequences for our views of space and time. We then consider how Newton's laws of motion must be modified to be valid for very high velocities and explore the idea of mass-energy equivalence. Finally, we briefly discuss the general theory of relativity.

### Chapter Outline

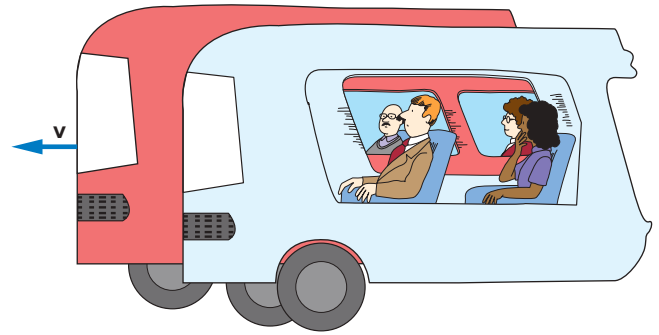
- 1 Relative motion in classical physics.** How did Galileo and Newton describe relative motion? How do velocities add when the frame of reference is moving?
- 2 The speed of light and Einstein's postulates.** What is the appropriate frame of reference for measuring the speed of light? How did experimental evidence lead to Einstein's postulates of special relativity?
- 3 Time dilation and length contraction.** How do Einstein's postulates lead to surprising conclusions about time and space? What are the effects of *time dilation* and *length contraction*?
- 4 Newton's laws and mass-energy equivalence.** How must Newton's second law of motion be modified to make it valid for very large velocities? How does the concept of mass-energy equivalence arise?
- 5 General relativity.** How does the theory of general relativity differ from the theory of special relativity? What new consequences emerge from the general theory?

**H**ave you ever been in a stationary bus, peering out the window at another bus sitting alongside when suddenly the other bus moved forward and you had the distinct sensation that your own bus was moving backward (fig. 20.1)? The sensation lasts until the other bus moves out of your view, and you realize you are not moving.

Your senses have deceived you because of the motion of your **frame of reference**. We normally measure our own motion with respect to objects that we expect to remain at rest. If these objects are fixed to the surface of the Earth, our frame of reference is the Earth: Position, velocity, and acceleration are measured relative to that frame. If objects that we have identified with that fixed frame of reference suddenly move, though, we may perceive ourselves as moving.

All motion must be measured with respect to some frame of reference, and that frame of reference may also be moving. The Earth rotates on its axis as well as orbits the sun. The sun, in turn, is moving with respect to other stars, and so on. Something at rest in one frame of reference may be moving with respect to some other frame of reference—so we must define our frame of reference to provide a complete description of motion.

The problem in defining a frame of reference, and in describing how a certain motion might look as it is seen from different frames of reference, was discussed by both Galileo and Newton. This is a simple problem if the relevant velocities are not large. Relative motion in this sense is part of our everyday experience. The motion of a boat relative to a flowing stream, for example, is familiar to many of us.



**Figure 20.1** The forward motion of an adjacent bus can give you the impression that your own bus is moving backward.

If we imagine ourselves moving along with a light beam, however, as Einstein may have imagined as a boy, some very interesting questions arise. Addressing some of these questions led to the **special theory of relativity**, introduced by Einstein in 1905. This theory is mainly concerned with cases in which different frames of reference move at constant velocity with respect to one another. The **general theory of relativity**, which Einstein published roughly 10 years later, deals with the relationship of gravity to accelerated frames of reference. Together, these theories have revolutionized the way we view the universe.

## 20.1 Relative Motion in Classical Physics

Imagine you have dropped a stick in the water of a moving stream and are watching its motion as it is carried along by the water (fig. 20.2). What is the velocity of the stick with respect to the bank of the stream? What is its velocity with respect to the water, and how are these two velocities related? How does this picture change if we consider a motorboat moving on a flowing stream? These questions can be addressed within the framework of classical mechanics developed by Galileo and Newton.

### How do velocities add?

When you drop a stick in the water, the stick swiftly reaches the velocity of the stream. Once that happens, its velocity with respect to the bank is the same as the water's velocity with respect to the bank, but the stick's velocity with respect to the water is zero. If you watched the stick from a boat that was also floating with the current, the stick would not seem to move.

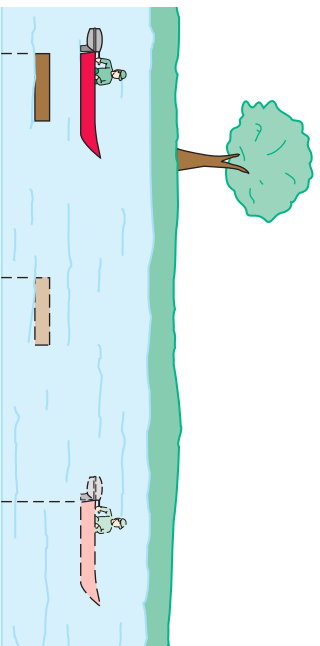
A more interesting situation arises if your boat is moving with respect to the water with the aid of oars, a motor, or a sail. In this case, the velocity of the boat relative to



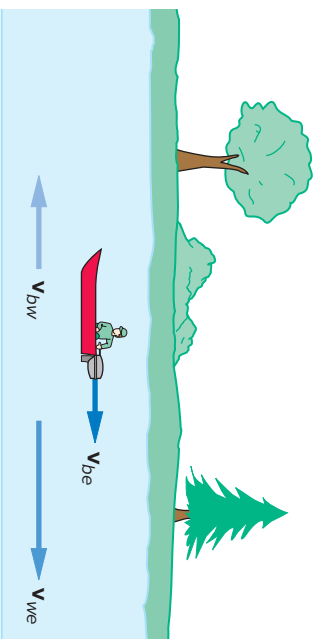
**Figure 20.2** A floating stick moves with the current. What is its velocity with respect to the stream bank?

*Jill Braaten*





**Figure 20.3** A motorboat and a piece of wood move downstream. The boat moves a distance  $d_{be}$  relative to the Earth while the wood moves a distance  $d_{we}$ .



**Figure 20.4** A motorboat moving upstream loses ground to the stream's current if it cannot travel fast enough relative to the water ( $v_{DW}$ ).

different direction of the velocities of the boat and the current can be indicated by a difference in sign. See example box 20.1.

### Example Box 20.1

#### Sample Exercise: Rowing with and against the Current

Two rowers, Derek and Teresa, are in a boat. Derek can row at a steady speed of 3.8 MPH, and Teresa can row at a steady speed of 4.6 MPH. If the water in the stream is moving at a speed,  $v_{we}$ , of 4.0 MPH relative to the bank, determine the velocity of the boat relative to the Earth (or bank),  $v_{be}$ , when (a) Derek rows against the current, (b) Teresa rows against the current, and (c) Derek rows with the current.

We will assume that the direction of the current, downstream, is negative. Therefore, if a velocity is positive, the movement is upstream (or against the current), and if it is negative, the movement is downstream (or with the current).

a. For Derek,  $v_{bw} = 3.8$  MPH.

$$\begin{array}{ll} v_{bw} = 3.8 \text{ MPH} & v_{be} = v_{bw} + v_{we} \\ v_{we} = -4.0 \text{ MPH} & v_{be} = 3.8 + (-4.0) \\ v_{be} = ? & v_{be} = -0.2 \text{ MPH (downstream)} \end{array}$$

b. For Teresa,  $v_{bw} = 4.6$  MPH.

$$\begin{array}{ll} v_{bw} = 4.6 \text{ MPH} & v_{be} = v_{bw} + v_{we} \\ v_{we} = -4.0 \text{ MPH} & v_{be} = 4.6 + (-4.0) \\ v_{be} = ? & v_{be} = +0.6 \text{ MPH (upstream)} \end{array}$$

c. For Derek,  $v_{bw} = -3.8$  MPH (downstream).

$$\begin{array}{ll} v_{bw} = -3.8 \text{ MPH} & v_{be} = v_{bw} + v_{we} \\ v_{we} = -4.0 \text{ MPH} & v_{be} = -3.8 + (-4.0) \\ v_{be} = ? & v_{be} = -7.8 \text{ MPH (downstream)} \end{array}$$

the water is not zero. The boat moves relative to the water, and the water moves relative to the stream bank (fig. 20.3). If the boat and the stream are moving in the same direction, we might assume that the velocity of the boat relative to the water should add to the velocity of the boat relative to the Earth. It is like walking on a moving escalator or one of those traveling walkways found in airports.

If we express this idea in symbols, it takes the form

$$v_{be} = v_{bw} + v_{we}$$

where  $v_{be}$  is the velocity of the boat relative to the Earth,  $v_{bw}$  is the velocity of the boat relative to the water, and  $v_{we}$  is the velocity of the water relative to the Earth. The velocity of the boat relative to the Earth is the vector sum of the velocity of the boat relative to the water and the velocity of the water relative to the Earth.

As shown in figure 20.3, our expectation that these velocities should add can be justified by considering the distances that the water and the boat travel in some fixed time. In this time, the piece of wood floating in the stream moves a distance  $d_{we}$ , which is the distance the water has moved relative to the Earth. In that same time, however, the boat has moved a distance  $d_{bw}$  relative to the water, so that it is now that much ahead of the piece of wood. The total distance the boat has moved relative to the Earth in this time,  $d_{be}$ , is the sum of the other two distances. Because the magnitude of the velocity (the speed) is distance divided by time, the velocities also add.

Although we have illustrated this idea for the simple case in which all three velocities are in the same direction, the velocity-addition result is valid more generally. For example, if we point the boat upstream (fig. 20.4), the

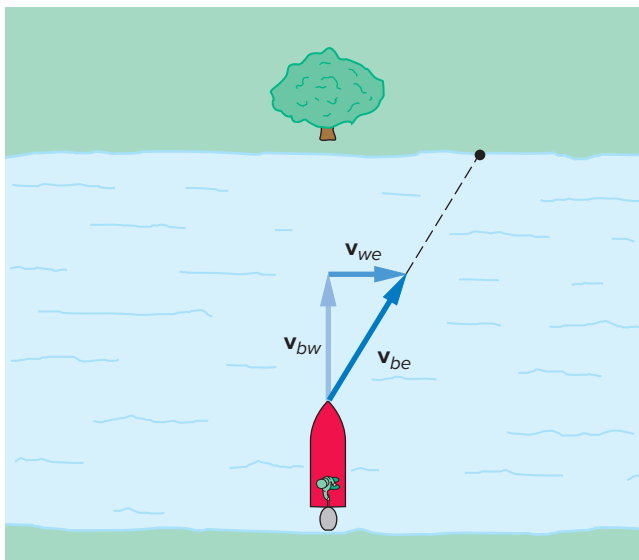
### How do velocities add in two dimensions?

Addition of relative velocities can also be extended to two or three dimensions. Suppose, for example, that you are traveling across the stream, as in figure 20.5. If you point the motorboat directly toward a point straight across the stream, will the boat end up at that point? Not if the stream is moving.

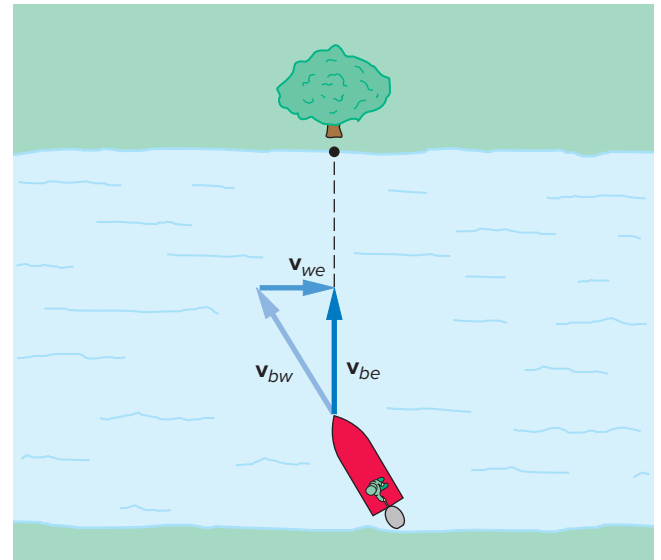
At the same time that the boat is moving across the stream relative to the water, the water is moving downstream relative to the Earth. The boat is carried downstream as it moves across the stream. As before, the two velocities add. (The vector addition process can be handled by the graphical method discussed in appendix C and illustrated in figure 20.5.) Notice that the size of the velocity of the boat relative to the Earth (its speed) will not be equal to the simple numerical sum of the other two speeds in this case. Because this velocity vector is the hypotenuse of a right triangle in the vector diagram, it will be equal to the square root of the sum of the squares of the other two sides.

If you wanted to hit a point on the bank directly across the stream from your starting point, you would have to point the boat somewhat upstream, at an angle to the line drawn perpendicular to the bank (fig. 20.6). In this case, when the two velocities add, they produce a velocity of the boat relative to the Earth that is straight across the stream. The magnitude of this velocity will be smaller than that of the boat relative to the water, however, as can be seen from the vector diagram.

We can apply the same analysis to an airplane. The velocity of the plane relative to the air ( $\mathbf{v}_{pa}$ ) adds to the velocity of the air relative to the Earth (the wind velocity,  $\mathbf{v}_{ae}$ ) to yield the velocity of the plane relative to the Earth,  $\mathbf{v}_{pe} = \mathbf{v}_{pa} + \mathbf{v}_{ae}$ .



**Figure 20.5** A motorboat pointed straight across the stream ends up at a point on the opposite bank that is somewhat downstream.



**Figure 20.6** The boat must be pointed somewhat upstream to travel straight across the stream.

A tailwind has a different effect from that of a headwind or a crosswind. The situation is directly analogous to the boat on the stream.

### The principle of relativity

Velocity addition can also be applied to events happening in moving vehicles. Imagine, for example, that you are walking up the aisle of a large airliner traveling with a constant velocity relative to the Earth. Your velocity relative to the plane must be added to that of the plane relative to the Earth to find your own velocity relative to the Earth. In practice, however, you are usually much more aware of your velocity relative to the plane than your velocity relative to the Earth—the plane is your frame of reference.

As long as the plane is moving with constant velocity, you can move about a large airliner quite easily without much awareness of the motion of the plane. In fact, you can throw a ball back and forth or perform physical experiments in the airplane and obtain the same results as if these experiments were done in a stationary building. (Because the Earth itself is rotating on its axis and orbiting the sun, it is not truly stationary, either.)

Even when a plane is moving with approximately constant velocity, we often have some sense of motion because of air turbulence causing it to bounce around. We also can look out the window and watch the clouds or Earth go by. In smooth air and with the window shades closed, though, we lose the impression we are moving. This loss is even more striking in an elevator moving up or down with constant velocity. Because elevators usually have no windows and can move very smoothly, it becomes hard to tell whether or not they are actually moving.

These ideas were discussed by both Galileo and Newton and are often summarized in the **principle of relativity**:

The laws of physics are the same in any inertial frame of reference.

This principle means that we cannot tell whether our frame of reference is in motion or not by performing physical experiments. As long as our frame of reference is moving with constant velocity with respect to other inertial frames of reference, the results of our experiments are the same.

### Inertial frames of reference

But what is an *inertial* frame of reference? At this point, logical difficulties arise, as Newton was well aware. Newton's second law of motion is valid only in an inertial frame of reference—that is, in any frame of reference for which Newton's first law is obeyed. If an object at rest remains at rest when the net force acting on the object is zero, that object is in an inertial frame of reference. Any frame of reference moving with constant velocity with respect to some valid inertial frame will also be an inertial frame of reference.

If some other frame of reference is accelerated with respect to a valid inertial frame, the accelerated frame is *not* an inertial frame of reference. If, for example, your airplane lurches up or down because of accelerations produced by air turbulence, your experimental results (and your ability to walk a straight line) are modified. Likewise, if an elevator is accelerating up or down, your apparent weight changes. If you were standing on a bathroom scale in the elevator, as discussed in chapter 4, this change would register on the dial. Other experiments would also have modified results due to this acceleration.

If we want to apply Newton's second law in these situations, we have to modify the law by adding imaginary or *inertial* forces that arise as a result of the acceleration of the frame of reference. The *centrifugal force* that we sometimes talk about feeling in a rotating frame of reference is such an imaginary force. A rotating frame has a centripetal acceleration and is not a valid inertial frame. We feel as though we are being pulled outward by a centrifugal force—but viewed from a valid inertial frame, we see that this apparent force is really just our own inertia at work, our tendency to continue moving in a straight line while our reference frame is turning.

The centrifugal force that seems to be present in a rotating frame of reference is not a valid force in the Newtonian sense, because it does not derive from the interaction of the affected body with any other body. In other words, it does not obey Newton's third law, which is part of Newton's definition of force. It arises solely due to the acceleration of the frame of reference. It is like the increase or decrease in apparent weight observed in an accelerating elevator.

Defining an inertial frame of reference seems easy enough: It is one that is not accelerated. But with respect to what? For many purposes, we can treat the surface of the Earth as an inertial frame of reference, because its acceleration is small. But the Earth is rotating as well as orbiting (in a curved path) about the sun, so it is accelerated with respect to the sun. The sun itself is accelerated with respect to other stars, so it is not a completely valid inertial frame of reference, either.

Our problem stems from the apparent impossibility of establishing a frame of reference that is absolutely at rest, or at least not accelerated in any sense. Maxwell's prediction and description of electromagnetic waves brought new attention to this problem in the latter half of the nineteenth century. The possibility that measuring the velocity of light could help to establish an absolute inertial frame of reference was an exciting idea. Questions about the appropriate reference frame for measuring the velocity of light led to Einstein's special theory of relativity.

The velocity of any object must always be measured with respect to some frame of reference. For ordinary motions, the surface of the Earth often provides that frame. If our frame of reference is moving with respect to some other frame, as with a boat on a flowing stream, the velocity of the boat relative to the stream can be added to the velocity of the stream relative to the Earth to obtain the velocity of the boat relative to the Earth. This process works in two or three dimensions, as well as for straight-line motion. Galileo and Newton recognized that the laws of physics take the same form in any inertial frame of reference. The difficulty comes in trying to establish an absolute inertial frame.

## 20.2 The Speed of Light and Einstein's Postulates

Light is an electromagnetic wave, which was originally predicted by Maxwell's theory of electromagnetism, as discussed in chapter 16. An electromagnetic wave consists of oscillating electric and magnetic fields that propagate through empty space, as well as through air, glass, and other transparent materials. Light waves can travel through a vacuum.

Is there a medium that light waves travel through even when they are passing through a vacuum? Most waves travel through some medium or material, sound waves through air (and other materials), water waves in water, waves on a rope on the rope itself, and so on. Does light also have a medium? At the end of the nineteenth century (and even now), this was one of the fundamental questions of physics.

### What is the luminiferous ether?

When Maxwell invented the concepts of electric and magnetic fields, he used a mechanical model to help him visualize

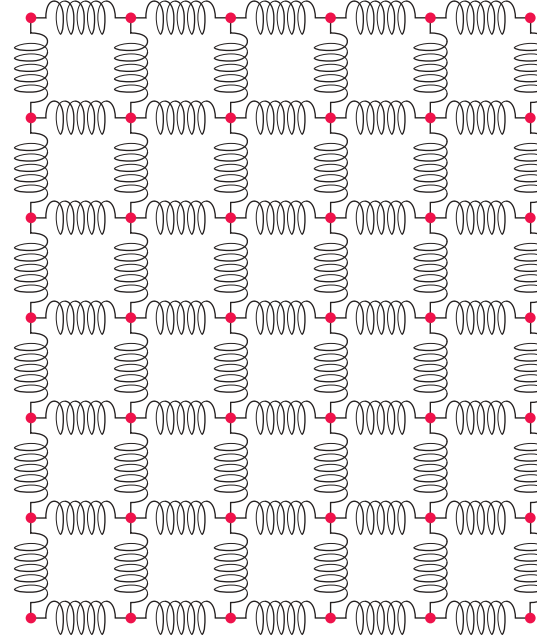
these ideas. An electric field can exist in otherwise empty space: It is the force per unit of charge that a charge would experience if placed at the point in space where the field exists. There does not have to be a charge (or anything else) there to define the field—the field is a property of space.

The presence of a field must somehow modify or distort space to produce its effect on a charged particle. Maxwell imagined empty space to have elastic properties. We could think of empty space as being like an infinite array of tiny, massless, interconnected springs (fig. 20.7). The changing electric and magnetic fields of an electromagnetic wave could be viewed as a distortion of this array of springs. Although Maxwell did not believe this was an accurate depiction of empty space, such a model may have helped him to think about fields and the process of wave propagation.

Even if this model was not to be taken literally, attributing elastic properties to empty space seemed necessary to explain the propagation of a wave through space. Otherwise, nothing oscillates as the wave passes through. This invisible, elastic, and apparently massless medium that could exist in a vacuum was called the *luminiferous ether*—it was the medium that light waves and other electromagnetic waves supposedly traveled through. Whether or not it was needed to explain the propagation of electromagnetic waves was a matter of debate. Maxwell himself was not totally convinced.

### Could the ether serve as a universal reference frame?

The supposed existence of the ether opened an exciting possibility for solving the problem of inertial frames of reference mentioned in section 20.1. Perhaps the ether could serve as an absolute or universal reference frame for measuring any motion. Any other valid inertial frame of reference



**Figure 20.7** Maxwell imagined empty space to have elastic properties. An array of massless, interconnected springs can serve as a crude model of this idea.

would then be traveling with constant velocity relative to the ether. The ether itself could be pictured as being embedded and fixed somehow in empty space.

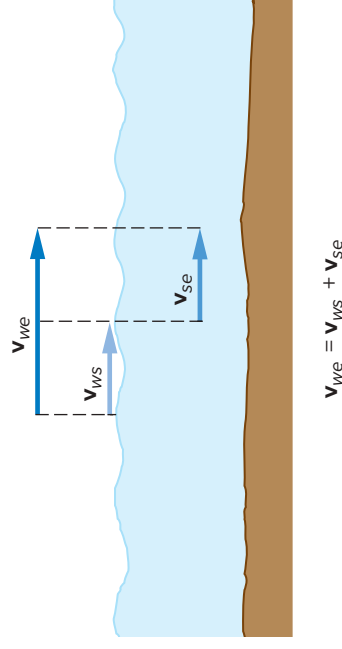
How could we measure motion relative to the ether? Simply by measuring the velocity of light. If the Earth is moving relative to the ether, the velocity of light should be affected by this motion. The velocity-addition formula introduced in section 20.1 should apply. This idea is easier to visualize if we consider a water wave on a flowing stream, as in figure 20.8.

If the wave is moving with a velocity  $\mathbf{v}_{ws}$  relative to the stream, and the stream is flowing in the same direction with a velocity  $\mathbf{v}_{se}$  relative to the Earth, the velocity of the wave relative to the Earth,  $\mathbf{v}_{we}$ , should be  $\mathbf{v}_{we} = \mathbf{v}_{ws} + \mathbf{v}_{se}$ , just like a boat going downstream. The velocity of the wave in the medium (the stream, in this case) adds to the velocity of the medium relative to the Earth to yield the overall velocity of the wave relative to the Earth.

Extending these ideas to light waves traveling in the ether is not difficult. If the Earth is moving through the ether, the ether is also flowing past the Earth. The velocity of light that we measure should then be the vector sum of the velocity of light relative to the ether and the velocity of the ether relative to the Earth. Accurate measurement of the velocity of light relative to the Earth at different times of the year would then let us determine whether or not the Earth was moving in a certain direction relative to the ether.

### The Michelson-Morley experiment

The most famous experiment designed to detect the possible motion of the Earth relative to the ether was performed by Albert Michelson (1852–1931) and Edward Morley (1838–1923) during the 1880s at what is now Case Western Reserve University in Cleveland. To detect small differences in the velocity of light, they used a special instrument designed by Michelson, now called the *Michelson interferometer*. As the name suggests, this instrument uses interference phenomena to detect small differences in the velocity of light (or the distance the light travels), as discussed in section 16.3.

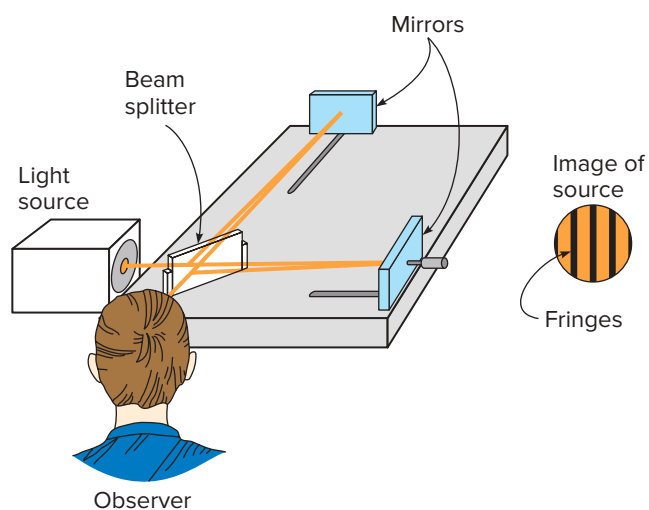


**Figure 20.8** The velocity of a wave relative to the stream adds to the velocity of the stream to yield the velocity of the wave relative to the Earth.

A Michelson interferometer is shown in figure 20.9. Light introduced from the source on the left is split into two beams by a partially silvered mirror, or beam splitter. Roughly half of the light striking this mirror passes through the mirror and half is reflected, producing two beams of equal intensity. These two beams travel along perpendicular paths, as shown, and are reflected by fully silvered mirrors, returning through the beam splitter. Here, the beams are partially transmitted and partially reflected again.

The observer looks at images of the source along a path on the fourth side of the interferometer at the bottom of the diagram. Because the light the observer sees has come from the same source but has traveled along different paths, it may be either in or out of phase for different points on the image of the source. If one of the end mirrors is slightly tilted, so that it is not exactly perpendicular to the light beam, these phase differences will create a pattern of dark and light fringes, as in figure 20.9. The dark fringes are produced by destructive interference, the light fringes by constructive interference.

If anything happens to change the time required for either one of the light beams to make its trip to the end mirror and back, the phase difference will change and the fringe pattern will shift. Michelson and Morley reasoned that if the ether was moving in a direction parallel to one of the arms, the time interval for the beam moving parallel to the ether stream would be slightly different from the time interval of the beam moving perpendicular to the ether stream. These time differences could be computed by finding the effective wave velocities for light traveling along each arm. The computation is similar to the one for a boat moving parallel or perpendicular to the current of a stream.



**Figure 20.9** A Michelson interferometer. Light waves traveling along the two perpendicular arms interfere to form a pattern of light and dark fringes.

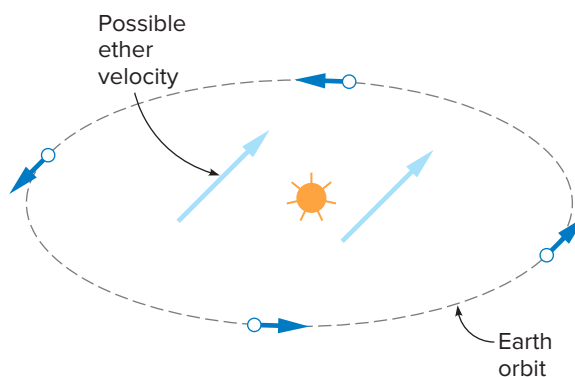
To see the expected shift of fringes, the interferometer must be rotated through 90° (along with the observer), so that the arm that had been parallel to the ether stream is now perpendicular to the ether stream, and vice versa. Michelson and Morley mounted the interferometer on a rock slab and floated the slab in a vat of mercury to let the interferometer rotate smoothly. (Mercury was the only obtainable fluid dense enough to float a heavy rock slab.)

Michelson and Morley based their computations on the assumption that the velocity of the Earth relative to the ether would be due, in part, to the orbital motion of the Earth around the sun. Because they could not assume that the ether was fixed with respect to the sun, they had to do the experiment at different times of the year. At some time during the year, the motion of the Earth should be parallel to a component of the ether's motion, and six months later it should be antiparallel (fig. 20.10). They assumed that the minimum velocity of the Earth relative to the ether would be equal to the orbital velocity of the Earth about the sun. It would have this value if the ether was fixed with respect to the sun. If the ether was moving relative to the sun, the relative velocity of the ether to the Earth would be even larger at some time during the year.

The results of the Michelson-Morley experiment were disappointing: No fringe shift was observed when the interferometer was rotated at any time during the year. Although the shift was expected to be small (of the order of half a fringe width), it should have been observable according to the assumptions the experiment was based on. The experiment failed to detect any motion of the Earth relative to the ether. Often in science, though, failing to find what is expected can be an important result.

### Einstein's postulates of special relativity

The failure of the Michelson-Morley experiment to detect any motion of the Earth relative to the ether raised new



**Figure 20.10** Regardless of the direction of the ether's motion relative to the sun, at some time during the year the Earth should be moving relative to the ether.

questions about the ether. Why could its motion not be detected? Maybe the ether was being dragged along with the Earth, much like the atmosphere, so that an experiment performed on the surface of the Earth would not detect motion. This assumption seemed to be precluded, however, by other observations involving shifts in the apparent positions of stars viewed at different times of the year.

Einstein was just a child at the time of the Michelson-Morley experiment and was not familiar with its results at the time of his initial work on relativity. However, he was aware of the debate regarding the existence of the ether. His solution to the dilemma was both simple and radical. He merely took as a basic postulate that the velocity of light is not affected by the motion of the source or of the frame of reference, since that seemed to be the case experimentally.

Einstein actually stated two postulates in his introductory paper on special relativity, published in 1905. The first was a reaffirmation of the principle of relativity stated similarly more than 200 years earlier by Galileo and Newton and discussed in section 20.1:

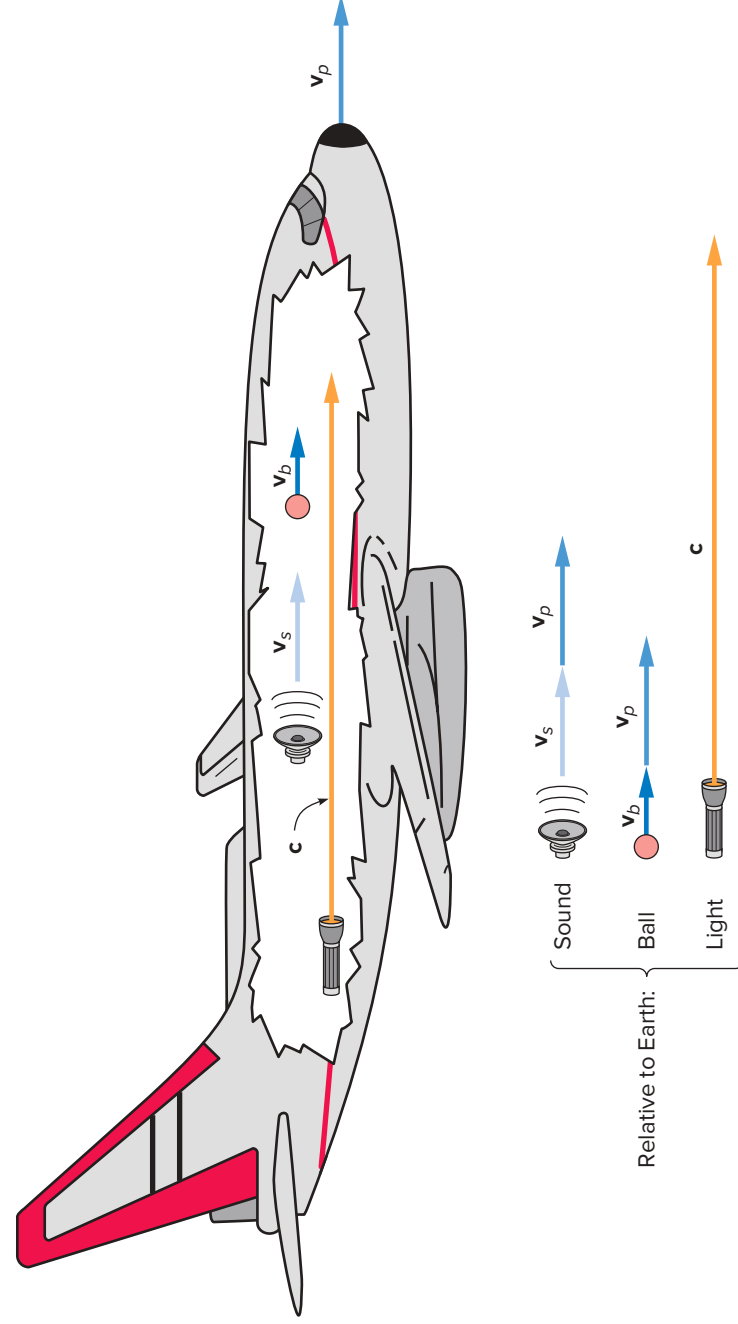
**Postulate 1:** The laws of physics are the same in any inertial frame of reference.

The second postulate involved the speed of light:

**Postulate 2:** The speed of light in a vacuum is the same in any inertial frame of reference, regardless of the relative motion of the source and observer.

Although both postulates are important to Einstein's theory, the second one calls for a radical change in thinking. What he was saying, in essence, is that light (or any electromagnetic wave) does not behave like most waves or moving objects. If we throw a ball on a moving airplane, the velocity of the ball relative to the Earth is the vector sum of the velocity of the ball relative to the airplane plus the airplane's velocity relative to the Earth. If the pilot speaks on the sound system, the sound wave travels with a velocity relative to the Earth that is the vector sum of the velocity of sound in the air of the airplane plus the airplane's velocity relative to the Earth (fig. 20.11).

If we shine a flashlight on the airplane, however, the velocity of light measured on the plane must be the same, according to Einstein's second postulate, as what is measured for the same flashlight beam by an observer at rest on the Earth. The classical velocity-addition formula does *not* hold for light—not an easy idea for physicists to accept in 1905. In fact, if we examine this second postulate more closely, we find it requires us to rethink space and time



**Figure 20.11** In contrast to sound waves or a ball, the velocity of the airplane does not add to the velocity of a flashlight beam to yield the speed of light relative to the Earth. The speed of light is the same for all observers. (Velocity vectors are not drawn to scale.)

themselves. This aspect of relativity really challenges our minds. We will begin to explore some of these consequences in section 20.3.

The ether was assumed to be the medium for electromagnetic waves. Because these waves could travel in a vacuum, the ether was thought to exist even in a vacuum. If the Earth moves through the ether, we might be able to establish an absolute frame of reference associated with the ether. The Michelson-Morley experiment was designed for this purpose but failed to detect any motion of the Earth relative to the ether. In response to this and other experiments, Einstein postulated that the speed of light is the same in any inertial frame of reference, denying the existence of the ether. This assumption holds radical implications for our concepts of space and time.

### 20.3 Time Dilation and Length Contraction

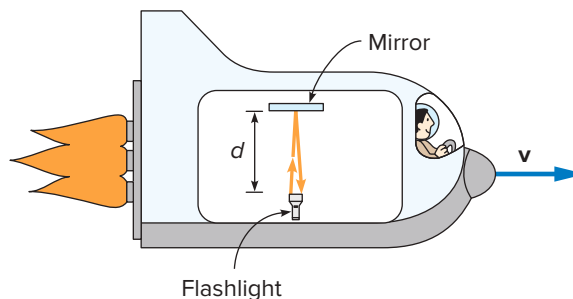
The units for velocity are always a ratio of distance (a measure of space) divided by time—for example, meters per second. The law of velocity addition depends on the assumption that space and time can be measured by different observers in the same manner and with the same results, regardless of whether these observers are moving relative to one another. This assumption is consistent with our daily experience.

If the velocity of light does not add like ordinary velocities, there must be some problem with how different observers measure space or time. If we accept Einstein's second postulate that the speed of light is the same for all observers, we must give up the ideas that space and time are the same for all observers. This goes against our intuition or common sense and requires us to throw out ideas that seem to be inherently true.

To approach these questions, Einstein devised *thought experiments*, experiments that are impractical to perform because of the tremendous velocities involved but that can be readily imagined and their consequences explored. Thought experiments allow us to see how the concepts of space and time must be altered to accept Einstein's second postulate. Anyone can do thought experiments; no physical equipment is required.

#### Measurements of time by different observers

Suppose that you wish to measure time using the velocity of light as your standard of measurement. Imagine, too, that you are riding in a spaceship moving with a large velocity with respect to the Earth. If your spaceship has a large glass window on one side, another observer standing on Earth could also watch your experiments and make measurements.



**Figure 20.12** In a light clock, the time taken for light to travel the distance  $2d$  to the overhead mirror and back becomes the basic measure of time  $t_0$ .

How would you go about using the speed of light as a standard for a time measurement? One way would be to send a light beam at a mirror directly overhead and use the time required for the beam to travel to the mirror and back as a basic unit of time. This arrangement would be a **light clock**—it would use the speed of light to establish a time standard. If the distance from the light source to the mirror is  $d$  (fig. 20.12), the time interval required for the light to travel to the mirror and back (a distance of  $2d$ ) is

$$t_0 = \frac{2d}{c}$$

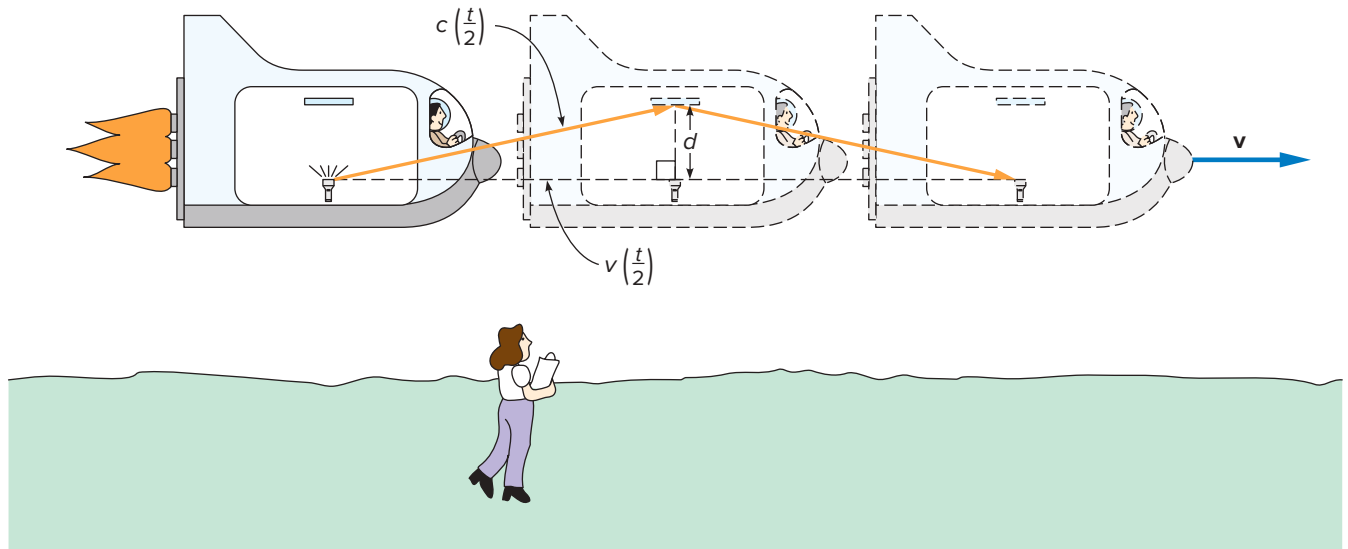
where  $c$  is the speed of light. This quantity becomes your basic measure or unit of time as measured in the spaceship.

The observer standing on the Earth as you flash by in your glass-walled spaceship can also see the time taken for the light beam to make its trip to the mirror and back. She views the events somewhat differently, though. If the spaceship is moving with a velocity  $v$  relative to the Earth, the mirror also moves at that velocity. For the light beam to be reflected from the mirror and return to the source (which, meanwhile, has moved), it must travel along the diagonal path shown in figure 20.13.

If the observer on Earth uses the same light clock to establish a measure of time, her basic measure  $t$  will be larger than  $t_0$ . She sees the light beam traveling a longer distance at the *same* speed  $c$  than the distance measured by the observer on the spaceship (yourself). We assume that she measures the vertical distance  $d$  in the same manner you do, because this distance is perpendicular to the direction of relative motion and should be unaffected by the motion. The longer path for the light beam yields a greater time.

The difference in the time intervals measured by the two observers can be found by considering the geometry and distances in figure 20.13. (See synthesis problem 5.) The time  $t$  measured by the Earth observer can be expressed in terms of the time  $t_0$  measured on the spaceship as

$$t = \frac{t_0}{\sqrt{1 - \frac{v^2}{c^2}}}$$



**Figure 20.13** To an observer standing on Earth, the light takes a diagonal path to the mirror and back to the source. This yields a longer time interval, as measured by the light clock.

This is the *time-dilation* formula. In it,  $t$  will always be larger than  $t_0$ , because the number in the denominator is always less than one. The observer on Earth measures a longer, *dilated* time with the light clock.

The time  $t_0$  is often called the **proper time**. In this case, it is the time interval measured in the spaceship where the light starts and finishes its trip at the same point in space.

A proper time interval is the elapsed time between two events measured in a frame of reference in which the two events occur at the same place within that frame of reference.

This is true for the time interval measured by the person on the spaceship, but not for the observer standing on Earth. The observer sees the light leaving the source at one point in space and returning to the source at a different point in space and measures a dilated time interval for the elapsed time between the start and finish of the beam's flight.

Step back and try to see what we have actually done in this thought experiment. We have used the speed of light as a standard for measuring time in a light clock. By insisting that the two observers moving relative to each other observe the same value for the speed of light  $c$ , we find that they arrive at different measures of time using the same clock. If they agree on the value of  $c$ , they cannot agree on the travel time of the light beam. Time does not pass at the same rate in the different frames of reference.

For ordinary speeds of relative motion, the difference in these two time intervals would be extremely small. For a speed of one-hundredth the speed of light ( $0.01c$ ), for example (still the enormous speed of 3 million meters per second), the quantity  $v/c$  in the time-dilation formula is 0.01. The dilated

time  $t$  in this case is just 1.000 05 multiplied by  $t_0$ , so the difference between  $t$  and  $t_0$  is very small. The relative speed  $v$  of the two observers must be almost as large as the speed of light for the difference in these time intervals to be noticeable.

The quantity containing the square root that appears in the time-dilation formula is involved in many relativistic expressions, and the Greek letter  $\gamma$  (gamma) is used as its symbol, where

$$\gamma = \frac{1}{\sqrt{1 - \frac{v^2}{c^2}}}$$

Table 20.1 shows the value of  $\gamma$  for a few values of the relative speed  $v$ . These values are very close to 1 for small values of  $v$  but increase rapidly as the magnitude of  $v$  approaches  $c$ . (The relative speeds are all expressed here as fractions of the speed of light  $c$ .) Written in terms of gamma, the time-dilation relationship takes the form  $t = \gamma t_0$ —that is, the proper time  $t_0$  must be multiplied by the factor  $\gamma$  to obtain the dilated time  $t$ .

**Table 20.1**

Values of  $\gamma$  for Different Values of Relative Speed  $v$

$v = 0.01c$	$\gamma = 1.000\ 05$
$v = 0.1c$	$\gamma = 1.005$
$v = 0.3c$	$\gamma = 1.048$
$v = 0.5c$	$\gamma = 1.155$
$v = 0.6c$	$\gamma = 1.250$
$v = 0.8c$	$\gamma = 1.667$
$v = 0.9c$	$\gamma = 2.294$
$v = 0.99c$	$\gamma = 7.088$



### How do length measurements vary for different observers?

Our two observers disagree on the elapsed time for the flight of the light beam, and they will also disagree on the distance the spaceship and the mirror traveled during this time. We can see this by extending our thought experiment to measure the distance the spaceship travels in the time required for one round trip of the light beam.

This distance can be measured most readily by the observer standing still on the surface of the Earth. With the help of assistants spaced along the path of the spaceship, she can mark where the spaceship is both when the light pulse is emitted and when it returns to the source. She can then measure the distance between these two points at her leisure, because this distance is fixed on the Earth's surface (fig. 20.14).

The observer in the spaceship has a somewhat more difficult task in measuring this distance. He sees the Earth as moving past him and must somehow locate the end points of the distance simultaneously. If he could measure the speed of the spaceship independently of this distance, he could then compute the distance by multiplying the speed  $v$  by the time of flight of the light beam. This quantity is the time  $t_0$ , the proper time, because that is the time measured by the astronaut. Using this method, he would measure a length  $L = vt_0$  for the distance covered by the spaceship during the flight of the light beam.

Using the same reasoning, the observer on Earth could also compute this distance. She finds  $L_0 = vt$ , where  $t$  is the dilated time that she measures for the flight of the light beam. We have used the symbol  $L_0$  because this is the **rest length**, the length measured by the observer who is at rest relative to the distance being measured. Given that we have already discovered that  $t$  is greater than  $t_0$ , we see that the

rest length  $L_0$  must be larger than the length  $L$  measured by the observer in the spaceship. He measures a *contracted*, or shorter, length than the rest length.

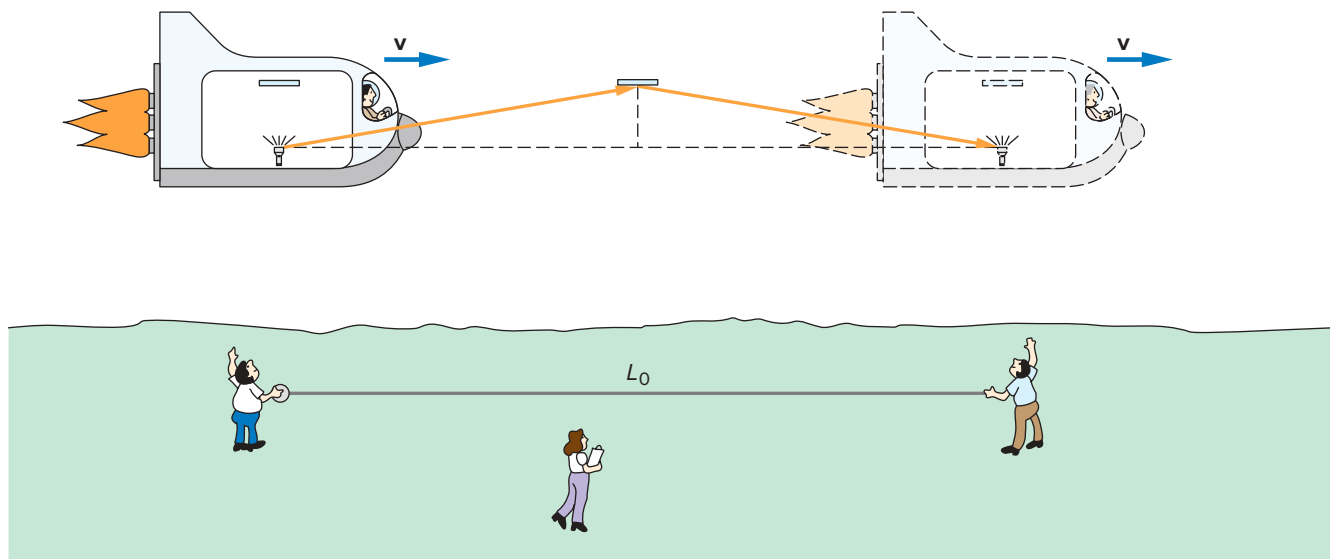
Because  $t = \gamma t_0$ , the contracted length can be expressed as

$$L = \left(\frac{1}{\gamma}\right) L_0$$

This is the *length-contraction* formula. Because  $\gamma$  is always greater than 1,  $L$  is always less than  $L_0$ , the rest length. Again, for the effect to be noticeable,  $v$  must be very large, as illustrated in example box 20.2. In this example, the spaceship is traveling with a velocity of  $0.6c$ . The spaceship's pilot measures a contracted length of 720 km for the trip distance, while the Earth observer measures the trip distance as 900 km. The pilot also measures a shorter time of 4 milliseconds (the proper time) for the trip than the 5-millisecond dilated time measured by the Earth observer.

Although these effects seem strange, they have been observed in a wide variety of circumstances. While ordinary-sized objects seldom move at speeds large enough to show noticeable effects, subatomic particles routinely travel at such speeds. A particle that has a certain lifetime at rest in the lab seems to have a longer (dilated) lifetime when it is moving at velocities near the velocity of light. It travels farther before decaying, as seen from the perspective of an observer at rest in the laboratory.

From the perspective of an observer traveling with the particle, however, the particle has its proper lifetime  $t_0$  and travels a contracted distance  $L$  shorter than the rest length measured by the laboratory observer. The situation is basically the same as for the spaceship in example box 20.2. All of these observations are consistent if we treat them according to Einstein's theory.



**Figure 20.14** With the help of assistants, the observer on Earth can mark the position of the spaceship when the light pulse is emitted and when it returns. The distance between these positions  $L_0$  can be easily measured.

## Example Box 20.2

### Sample Exercise: A Contraction in Length

A spaceship traveling at the velocity of  $1.8 \times 10^8$  m/s ( $0.6c$ ) covers a distance of 900 km, as measured by an observer on the Earth.

- What is the distance traveled in this time, as measured by the pilot of the spaceship?
- How much time does it take to cover this distance, as measured by the observer on Earth and as measured by the pilot?

a.  $v = 0.6c$                       From table 20.1,  
 $c = 3 \times 10^8$  m/s               $\gamma = 1.25$   
 $L_0 = 900$  km                       $\frac{1}{\gamma} = \frac{1}{1.25}$   
 $L = ?$                                        $\frac{1}{\gamma} = 0.8$

$$L = \left(\frac{1}{\gamma}\right) L_0$$

$$= (0.8)(900 \text{ km})$$

$$= \mathbf{720 \text{ km}}$$

b.  $t = ?$                       As seen by the observer on Earth:  $L_0 = vt$   
 $t_0 = ?$                        $t = \frac{L_0}{v}$

$$= \frac{9 \times 10^5 \text{ m/s}}{1.8 \times 10^8 \text{ m/s}}$$

$$= 5 \times 10^{-3} \text{ s} = \mathbf{5 \text{ ms}}$$

As seen by the spaceship pilot:  $L = vt_0$

$$t_0 = \frac{L}{v}$$

$$= \frac{7.2 \times 10^5 \text{ m/s}}{1.8 \times 10^8 \text{ m/s}}$$

$$= 4 \times 10^{-3} \text{ s} = \mathbf{4 \text{ ms}}$$

The problem of measuring distances from a moving spaceship, if examined closely, boils down to a problem of simultaneously locating the end points of the length being measured. Not only will two observers disagree on the elapsed time, they will also disagree about whether events are simultaneous or not. Two events separated in space may be seen as being simultaneous by one observer but as occurring at different times by an observer moving relative to the first observer.

These space and time effects are explored further in everyday phenomenon box 20.1 using the famous *twins*

*paradox*. The paradox involves the difference in aging rates of two twins, one who makes a space trip to a distant star and back and one who remains on Earth. The fact that the traveling twin ages less than the one remaining on Earth can be understood using the concept of time dilation. It is not just science fiction!

If we accept Einstein's second postulate that the speed of light has the same value for different observers, regardless of their relative motion, we must give up some cherished ideas about space and time. Using the speed of light as a standard for time measurements, we find that a dilated, or longer, time is measured between two events for an observer who does not see these events as occurring at the same place in space. Also, an observer who is moving relative to a distance being measured finds a contracted, or shorter, length. Different observers cannot even agree on whether two events are simultaneous or not.

## 20.4 Newton's Laws and Mass-Energy Equivalence

Accepting Einstein's postulates requires some major changes in how we think about space and time. Because space and time measurements are involved in velocity and acceleration, and acceleration plays a key role in Newton's laws of motion, we might suspect that Newton's laws must also be modified to be consistent with Einstein's postulates. Does Newton's second law of motion still apply when objects are moving at very large velocities?

In addressing these questions, Einstein discovered that it was necessary to modify Newton's second law by redefining the concept of momentum. As he explored the consequences of this new approach to dynamics in his early papers on relativity, he was also led to a striking conclusion about the relationship between mass and energy, summarized in the oft-quoted equation  $E = mc^2$ .

### How must Newton's second law be modified?

When Einstein examined Newton's second law in the light of his postulates, he discovered problems: An acceleration measured in one frame of reference is not the same as the acceleration of the same object measured in some other frame of reference. If a spaceship pilot fired a projectile with a certain acceleration, the observer on Earth would measure a different acceleration.

At ordinary velocities, there is no difference in the accelerations measured by different observers. We can apply Newton's second law,  $\mathbf{F}_{\text{net}} = m\mathbf{a}$ , in any inertial frame of reference using the same forces to explain the acceleration of the object. Newton's second law apparently will not work

## Everyday Phenomenon

## Box 20.1

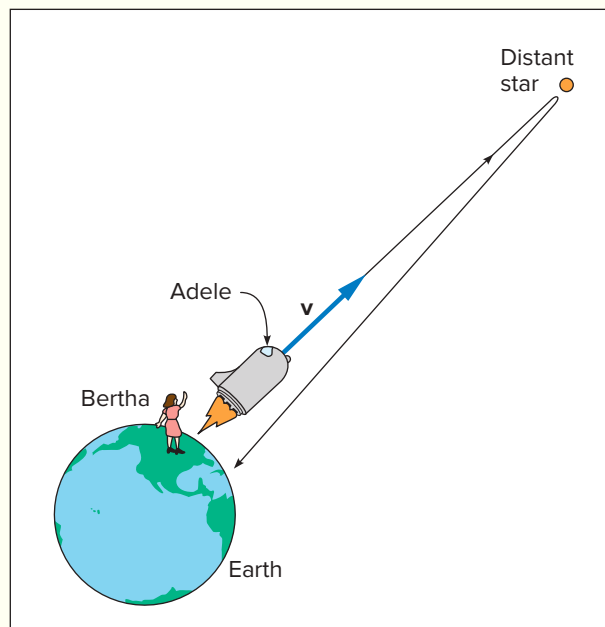
## The Twin Paradox

**The Situation.** One of the most discussed phenomena of relativity is the *twin paradox*. One of a pair of identical twins, Adele, journeys at very large velocities to a distant star and then returns to Earth. The second twin, Bertha, remains on Earth the entire time her twin is traveling.

Because one of the twins is traveling at a speed approaching the speed of light, the twins should measure time as passing at different rates because of time dilation. When the traveling twin returns, will she find that she is younger than the twin who stayed at home? Because each twin can regard the other as moving while she herself is standing still (as long as the velocity is constant), shouldn't the other twin also see herself as younger? This question lies at the heart of the apparent paradox.

**The Analysis.** Suppose that Adele's entire trip is made at the speed  $v = 0.6c$ . From table 20.1, the factor  $\gamma$  that appears in the time-dilation formula is equal to 1.25. If Adele perceives the trip as taking 12 years, this is a proper time in her frame of reference, the spaceship. She has lived 12 years and experienced an appropriate number of heartbeats (or other suitable biological measures of time) during her trip. In other words, as far as she is concerned, she is 12 years older than when she left.

Her twin, Bertha, on the other hand, experiences a dilated time for the same time interval. She lives a time  $t = \gamma t_0$ , which is



Twin Adele travels to a distant star and back while her twin sister, Bertha, remains at home.

15 years ( $1.25 \times 12$  years) for the trip. Bertha has aged 15 years waiting for her sister to return. Because Adele has aged only

when the velocities are very large, because the accelerations are no longer equal in different frames of reference. We then have a violation of Einstein's first postulate: Newton's second law does not seem to take the same form in different inertial frames of reference.

As discussed in chapter 7, the most general form of Newton's second law is stated in terms of momentum rather than acceleration,  $\mathbf{F}_{\text{net}} = \Delta\mathbf{p}/\Delta t$ —the net force equals the rate of change of momentum. Momentum is defined as the product of the mass multiplied by the velocity,  $\mathbf{p} = m\mathbf{v}$ . We also find problems at large velocities when we attempt to use Newton's second law in this form. Even the law of conservation of momentum does not seem to work when viewed by observers in different frames of reference.

To salvage the law of conservation of momentum at relativistic (large) velocities, Einstein found that he had to redefine momentum as

$$\mathbf{p} = \gamma m\mathbf{v}$$

Here,  $\mathbf{v}$  is the velocity of an object with respect to a given frame of reference and  $\gamma$  is the relativistic factor defined in

section 20.3, which also depends on the magnitude of the velocity  $v$ . Using this new definition of momentum, Einstein was able to show that different observers could agree that momentum was conserved in a collision, even though these different observers would measure different values for the velocities and momenta. At low velocities, this revised definition of momentum reduces to the ordinary definition of momentum,  $\mathbf{p} = m\mathbf{v}$ , because the factor  $\gamma$  is then approximately equal to 1.

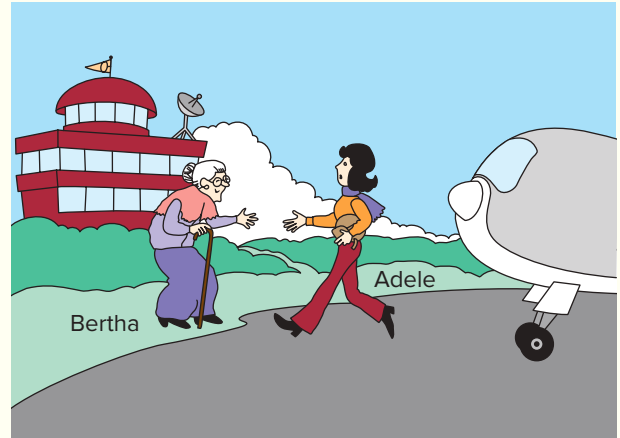
Because the law of conservation of momentum follows directly from Newton's second law, this revised definition of momentum must be used there also. In other words, Einstein found that he could make Newton's second law conform to his postulates by using the new definition of momentum in the general form of Newton's second law,  $\mathbf{F}_{\text{net}} = \Delta\mathbf{p}/\Delta t$ . At ordinary velocities, Newton's second law works the usual way, because the relativistic momentum reduces to the classical definition. At very large velocities, we are forced to use the relativistic definition of momentum. Einstein's special theory of relativity is a significant revision of Newton's theory of mechanics.

12 years during the trip, Adele is 3 years younger than her identical twin at the end of the trip!

Suppose, however, that we did the same analysis with the spaceship as fixed and the Earth as moving. Would we arrive at the reverse conclusion to what we just computed? Would such an analysis suggest that Bertha should be 3 years younger than Adele? Surely we cannot hold both of those results to be true. Therein lies the paradox.

The resolution of the paradox lies in the fact that we have ignored the accelerations and the resulting changes in reference frame. To make a space trip such as this, Adele's spaceship must accelerate away from Earth until it reaches the enormous speed of  $0.6c$  that we have assumed. When it reaches the distant star, it must turn around, which involves a deceleration and acceleration in the opposite direction (and into a different frame of reference). It must decelerate again when it reaches the Earth. Our situation is not really completely symmetric: The spaceship exists in two different frames of reference, each having speed  $v$  relative to the Earth but with velocities in opposite directions.

Although accelerations can be handled using general relativity, this is not really necessary for our purposes. If we assume that the accelerations take place in time intervals that are small compared to the overall time of flight, the computation done earlier using special relativity produces the correct result—Adele does age less than Bertha. This can be confirmed by doing a thought experiment using the basic assumptions of special relativity and carefully treating the behavior of clocks in either frame of reference. We must assume, however, that the spaceship changes frames of reference, not the Earth.



At a spaceship speed of  $0.995c$ , the differences in aging of Adele and Bertha could be quite striking.

This difference in the passage of time and the resulting difference in aging of the twins is a real effect that has been confirmed experimentally using highly accurate clocks and the much slower speeds of a jet plane. If we could reach velocities as high as  $0.995c$ , the difference in aging of the twins would be quite striking. At a velocity of  $0.995c$ , the time-dilation factor is approximately 10 rather than 1.25. A trip that took 10 years for Adele would take 100 years for Bertha. Adele would return to Earth 100 Earth-years later having aged only 10 years herself.

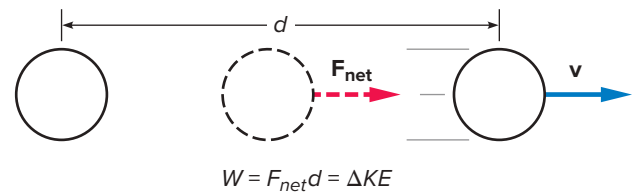
### How did the idea of mass-energy equivalence emerge?

As he revised Newton's second law, Einstein discovered that mechanical energy also took on a new meaning. In classical physics, the kinetic energy of an object is found by computing the work done to accelerate the object to a given speed, resulting in the familiar expression  $KE = \frac{1}{2}mv^2$ . (See chapter 6 and figure 20.15.) Using the same procedure, we can compute the kinetic energy for an object accelerated to a very large velocity. In this case, however, we must use the modified version of Newton's second law to describe the process of acceleration.

When Einstein computed the kinetic energy using the relativistic modification of Newton's second law, he obtained the result

$$KE = \gamma mc^2 - mc^2$$

Note that only the first term in this expression depends on the speed of the object, because the factor  $\gamma$  contains the speed. The second term is independent of the speed of the object.



**Figure 20.15** As before, the work done by the net force used to accelerate an object equals the increase in the kinetic energy of the object.

Arriving at this result was a simple process for Einstein (the computation is not difficult for someone experienced in using calculus). Interpreting the result, however, offered a significant challenge. The new expression for kinetic energy is the difference between two terms, one that depends on the speed and another that does not. Apparently, accelerating an object increases the energy of the object above an energy that it already possesses by virtue of its mass,  $mc^2$ .

The quantity  $mc^2$  is often called the **rest energy** and is given its own symbol,  $E_0 = mc^2$ . The expression for the

kinetic energy obtained by Einstein can be rearranged, putting the rest energy on the other side of the equation with the kinetic energy,  $KE + E_0 = \gamma mc^2$ . The expression  $\gamma mc^2$  is the total energy, the sum of the kinetic energy and the rest energy. When an object is accelerated, the total energy and the kinetic energy increase, because the factor  $\gamma$  increases as the speed increases.

### How do we interpret the rest energy?

The rest energy term was the most interesting feature of Einstein's computation of the kinetic energy. Because  $c$  is a constant of nature, in multiplying the mass of an object by  $c^2$  to obtain an energy value ( $mc^2$ ), we are just multiplying the mass by a constant. What this seems to indicate is that mass is *equivalent to* energy. If we increase the mass of an object or system, we increase its energy—if we increase the energy of a system, we increase its mass. This is the essence of the  $E_0 = mc^2$  relationship.

Mass-energy equivalence is illustrated in figure 20.16, which shows a Bunsen burner heating a beaker of water. Because heat flow is a flow of energy, we increase the internal energy of the water by heating it. We are also increasing the mass of the water, because energy is mass. The amount the mass increases in this example is very small and extremely difficult (if not impossible) to measure. If we add 1000 joules of heat energy, the increase in mass is just  $1.1 \times 10^{-14}$  kg, as



**Figure 20.16** A Bunsen burner adds mass to a flask of water by increasing the internal energy of the water. Energy and mass are equivalent.

Richard Megna/Fundamental Photographs, NYC

## Example Box 20.3

### Sample Exercise: Adding Energy Adds Mass

A Bunsen burner adds 1000 J of heat energy to a beaker of water. What is the increase in the mass of the water?

$$\begin{aligned}
 E &= 1000 \text{ J} & E &= \Delta mc^2 \\
 c &= 3 \times 10^8 \text{ m/s} \\
 \Delta m &= ? & \Delta m &= \frac{E}{c^2} \\
 & & &= \frac{1000 \text{ J}}{(3 \times 10^8 \text{ m/s})^2} \\
 & & &= \frac{1000 \text{ J}}{9 \times 10^{16} \text{ m}^2/\text{s}^2} \\
 & & &= 1.11 \times 10^{-14} \text{ kg}
 \end{aligned}$$

shown in example box 20.3. Because a beaker of water would normally contain a few tenths of a kilogram of water, a change of  $10^{-14}$  kg would be utterly negligible.

Because we are so used to thinking of mass and energy as different, the idea that mass is equivalent to energy can be hard to accept. The principle itself has been thoroughly confirmed, because it correctly predicts the amount of energy released in nuclear reactions such as fusion or fission, as described in chapter 19. It is sometimes stated that mass is converted to energy in such reactions, but it would be better to say that rest-mass energy has been transformed to kinetic energy. In other words, mass cannot be converted to energy, because it already is energy—we are merely transforming one type of energy into another.

Mass-energy equivalence, like the other ideas we have been describing, is just another result of applying Einstein's postulates carefully and consistently to mechanics. The surprising results have led to fundamental revisions in our understanding of the concepts of energy and mass, as well as of space and time.

Further exploration of Einstein's postulates showed that different observers could not agree on acceleration values, or even that momentum is conserved. A modification of Newton's second law of motion was required, which was accomplished by changing the definition of momentum in the general form of the second law. Using the modified form of the second law also changes the expression for kinetic energy. One of the terms in the new expression for kinetic energy does not depend on the speed of the object, suggesting the concept of a rest energy associated with the mass of the object. Mass-energy equivalence has since been demonstrated dramatically in nuclear reactions.

## 20.5 General Relativity

Our discussion so far has been restricted to cases involving inertial frames of reference—that is, reference frames moving at constant velocity relative to one another. What happens if our frame of reference is accelerating? Can we extend the type of thinking used in special relativity to this situation?

Einstein addressed these questions shortly after his introduction of the theory of special relativity, but it took him some time to refine the ideas. He did not publish the resulting general theory of relativity until 1915, about 10 years after his first paper on special relativity. Once again, Einstein's ideas led to radical adjustments in our view of the universe.

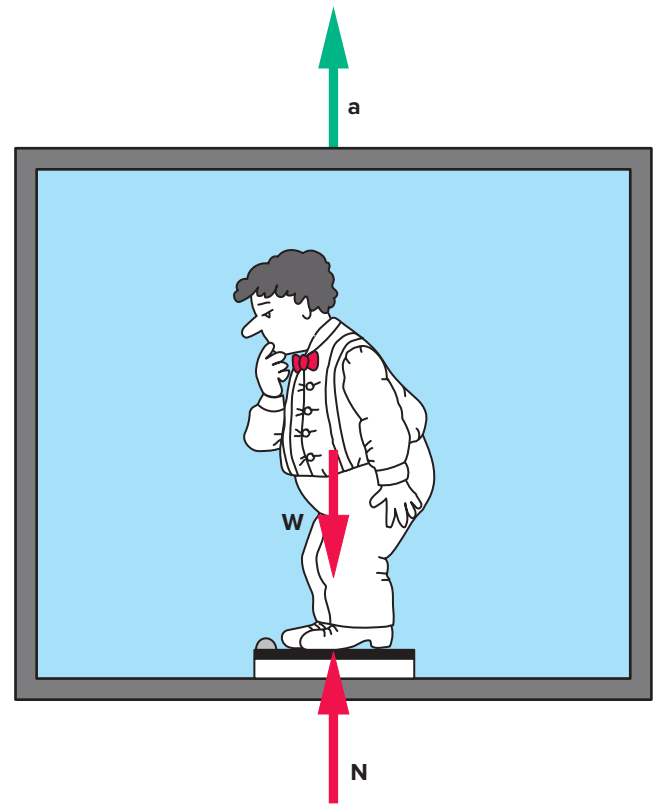
### What is the principle of equivalence?

We discussed accelerating reference frames earlier, when we considered how things appear to someone inside an accelerating elevator, at the beginning of this chapter and in chapter 4. If the elevator is moving with constant velocity, Einstein's first postulate (the principle of relativity) tells us that the laws of physics will behave exactly as they would if the elevator were at rest. In other words, no experiment that we can do inside the elevator could establish whether or not we were moving with respect to the Earth.

If the elevator were accelerating, we would expect the observations we made to be different from what we had observed when the elevator was moving with constant velocity (or when it was at rest). In particular, as discussed in chapter 4, a person standing on a bathroom scale while the elevator is accelerating upward will register a greater weight than if the elevator were not accelerating (fig. 20.17). From Newton's second law, this greater apparent weight results from the scale's exerting a larger upward force on your feet (the normal force) than your actual weight. The net upward force makes you accelerate upward along with the elevator.

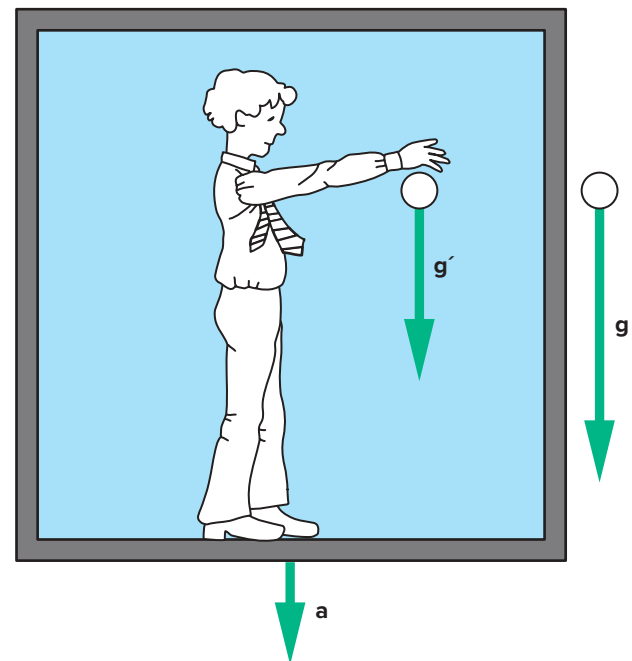
This change in the scale reading can be used as an indication that the elevator is accelerating. If the elevator is accelerating upward, the reading will be higher than normal. If the elevator is accelerating downward, the reading will be lower than normal. If the cable of the elevator is cut and the elevator accelerates downward with an acceleration  $g$  (free fall), the scale will read zero—apparent weightlessness. Until things come to a crashing halt at the bottom of the shaft, you can float around inside the elevator much like an astronaut in an orbiting space station.

Other experiments will also lead to results that you would not expect if the elevator were not accelerated. For example, a dropped ball will approach the floor of the elevator with an apparent acceleration that is different from  $g = 9.8 \text{ m/s}^2$ . If the elevator is accelerating upward, the apparent acceleration of the ball will be larger than  $g$ : It is the sum of the magnitude of the acceleration of the elevator  $a$  and the gravitational acceleration  $g$ . If the elevator is accelerating downward, the apparent acceleration of the ball will be less than  $g$ , as



**Figure 20.17** If the elevator is accelerating upward, the scale reads a value  $N$ , which is larger than the person's usual weight  $W$ .

figure 20.18 shows. The period of a swinging pendulum will also differ from the one you would observe if the elevator were not accelerating.



**Figure 20.18** A ball dropped in an elevator accelerating downward approaches the floor with an apparent acceleration  $g'$  that is less than  $g$ .

These experiments all have one thing in common: They can be interpreted in terms of an apparent acceleration of gravity that differs from  $g = 9.8 \text{ m/s}^2$ . Because weight is equal to mass times the acceleration of gravity ( $mg$ ), the changes in apparent weight can be attributed to a change in the apparent value of the gravitational acceleration. We explain the changes in the acceleration of the ball or the period of the pendulum in the same way. Although we can detect the acceleration of the elevator, we cannot distinguish these effects from what would happen if the acceleration due to gravity were being increased or decreased somehow.

Our inability to distinguish these accelerations underlies Einstein’s basic postulate of general relativity, the **principle of equivalence**:

It is impossible to distinguish an acceleration of a frame of reference from the effects of gravity.

From inside the elevator, you cannot tell whether the elevator is accelerating or whether the gravitational acceleration  $g$  is increasing or decreasing. Because we do not expect gravity to change, we usually interpret the effects as being due to an acceleration of our frame of reference.

Let’s move our elevator to outer space, where gravitational effects are much smaller than near the surface of the Earth. If the elevator is not accelerating, we will be weightless. If the elevator is accelerating upward, however, any experiments performed in the elevator will behave as though a gravitational acceleration is acting in the direction opposite the acceleration of the elevator.

If a ball is thrown horizontally in the elevator (fig. 20.19), its trajectory will be the same as a ball thrown on the surface of

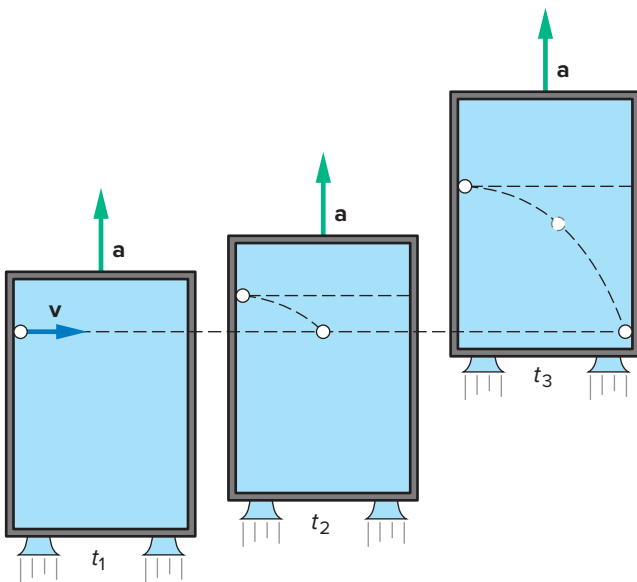
the Earth. From the perspective of someone inside the elevator, the upward acceleration of his or her frame of reference is equivalent to the presence of a downward gravitational acceleration of the same magnitude as the acceleration of the elevator. (This is the principle of equivalence at work.) The ball “falls” toward the floor of the elevator, and we can predict its motion by the same methods used in chapter 3 to describe projectile motion.

If the acceleration of the elevator were equal to  $9.8 \text{ m/s}^2$ , mechanical experiments done in the elevator and on the surface of the Earth would have identical results. It has often been proposed that a space station should have a constant acceleration to mimic the effects of gravity. A straight-line acceleration would send the space station out of orbit, so we usually imagine the space station with a centripetal acceleration associated with a constant rotational velocity. Because the direction of a centripetal acceleration is toward the center of rotation, that direction would be up (fig. 20.20).

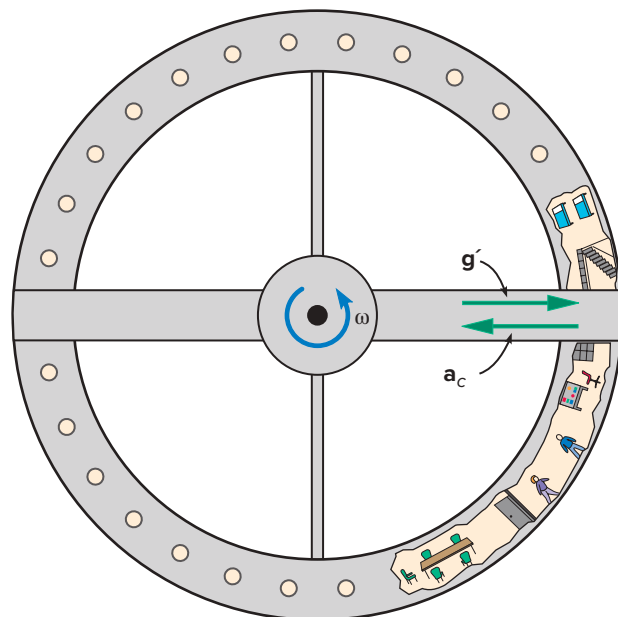
### Does a light beam bend in a strong gravitational field?

The principle of equivalence also has implications for the propagation of light. Imagine an experiment similar to the one in figure 20.19 but using a beam of light instead of a ball. If the elevator were not accelerating, the beam would trace a horizontal line across the elevator. From the theory of special relativity, we know that this is true whether or not the elevator is moving with constant velocity relative to any other inertial frame of reference.

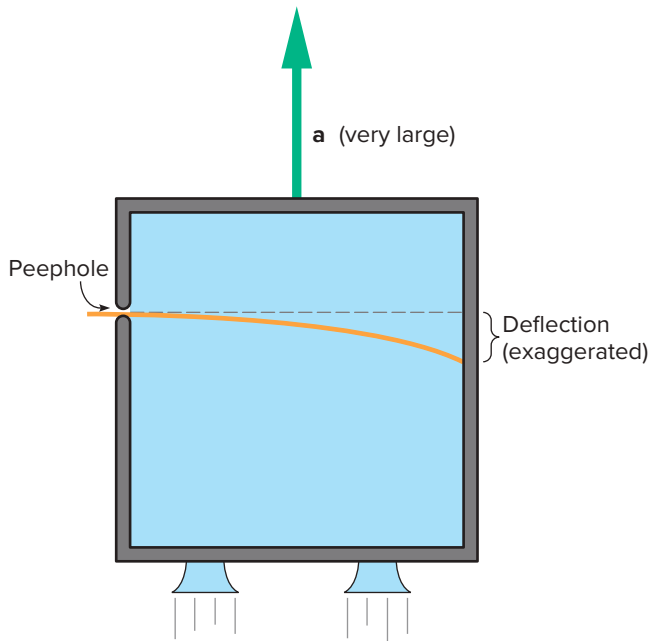
If the elevator is accelerating upward, however, we get a different result. If the acceleration is large enough, the path



**Figure 20.19** A ball thrown horizontally in an accelerating elevator in outer space (where the Earth’s gravitational pull is negligible) falls toward the floor in the same way as a projectile near the Earth’s surface.



**Figure 20.20** The centripetal acceleration  $a_c$  of a rotating, wheel-like space station can produce an artificial gravitational acceleration  $g'$  for the astronauts.



**Figure 20.21** The path traced by a beam of light relative to a rapidly accelerating elevator is curved because of the motion of the elevator.

of the light beam will be curved, as viewed from within the elevator, like the ball's path in figure 20.19. This bending can be visualized by superimposing the positions of the accelerated elevator on the straight-line light beam observed from outside of the elevator, just as we did for the ball. As shown in figure 20.21, the path traced by the beam relative to the elevator is curved.

By the principle of equivalence, however, we cannot distinguish the acceleration of our frame of reference from the presence of a gravitational acceleration. We should therefore expect the path of a light ray to be bent in passing through a strong gravitational field. It takes a very large acceleration of the frame of reference or a very large gravitational acceleration to produce a noticeable bending because of the extremely large velocity of light. The relatively puny field of the Earth is not enough to produce much of an effect.

When light from a distant star passes near our sun, however, the gravitational field of the sun should be large enough to have a measurable effect. Einstein was able to predict how much bending is produced by the gravitational field of the sun—and how the true position of stars is distorted when light from these stars passes near the sun. The effect is small but measurable.

Unfortunately, it is difficult to observe stars from the surface of the Earth during the daytime. Light from the sun is scattered in the Earth's atmosphere and completely washes out the much more feeble light of the stars. Such observations are feasible only during a total eclipse of the sun, when the light from the sun is blocked by the moon. Einstein suggested that such measurements be attempted during a total eclipse, and this has since been done almost every time the opportunity has arisen. These measurements have confirmed Einstein's predictions.

### What are the space and time effects of general relativity?

Special relativity tells us that different observers moving with respect to one another will disagree on measurements of time. In the time-dilation effect, the time interval measured by observers who see the start and finish of some process occurring at the same place in their frame (the proper time) is shorter than the time interval measured by observers moving with respect to that frame. The astronaut in the twin paradox measures the proper time for events occurring in her frame, which is shorter than the dilated time measured by her stay-at-home twin. The astronaut's clock runs slower than her twin's clock and the astronaut measures a shorter time.

In general relativity, we also find that an accelerated clock runs more slowly than a non-accelerated clock. By the principle of equivalence, we also expect a clock in a strong gravitational field to run more slowly than one in a weaker gravitational field. This time effect predicted by general relativity is often referred to as the **gravitational red shift**. If the period (the time for one cycle) of a light wave is increased, the frequency is decreased. A lowered frequency shifts the light toward the red end of the visible spectrum.

The general theory of relativity is largely about the nature of gravity. Gravity affects a straight-line path, as well as time—it has an impact on how we measure both space and time. To develop a self-consistent mathematical framework for handling these effects, Einstein resorted to a non-Euclidean, or curved, space-time geometry.

Briefly, in Euclidean, or ordinary, geometry, two parallel lines never meet, but in non-Euclidean geometry, two parallel lines *can* meet. An example is parallel lines drawn on the surface of a sphere, such as the lines of longitude on maps. The parallel lines drawn perpendicular to the equator meet at the poles, because the surface they are drawn on is a sphere (fig. 20.22). It is all a matter of how we define the rules of geometry.



**Figure 20.22** Parallel lines of longitude drawn on the globe meet at the poles of the sphere.

Jill Braaten/McGraw-Hill Education



Einstein's theory of special relativity showed that the measurement of time depends on spatial measures, while the measurement of length depends on time measurements. Therefore, we can no longer regard space and time as independent of each other. To fully represent these ideas using geometry, we must use four dimensions, or coordinates: three perpendicular spatial coordinates and a fourth one representing time. To describe a motion or event, we need to locate its path in this **space-time continuum**.

Although the space-time continuum is four-dimensional and somewhat difficult to visualize, diagrams like figure 20.23 illustrate how space might be curved near a very strong gravitational field. The diagram shows only two dimensions on a curved surface, but it does suggest how things might be pulled, drainlike, into the center of the field. Because light rays are bent by strong gravitational fields, they, as well as particles having some mass, can be pulled into the center of the field.

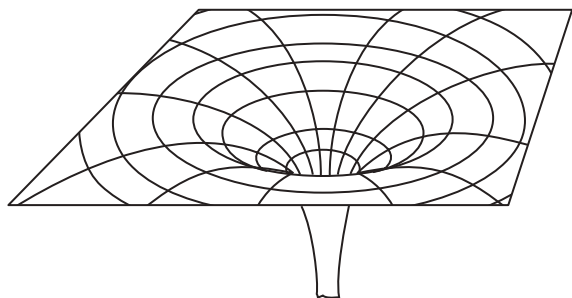
### What is a black hole?

Figure 20.23 is a two-dimensional representation of a **black hole**. Black holes are thought to be very massive, collapsed stars that generate an extremely strong gravitational field and, therefore, a strong curvature of space in their vicinity. This field is so strong that light rays coming in at certain angles are bent into the center and do not reemerge. Light gets in but cannot get out. A black hole is a perfect absorber of light and appears black.

Although black holes cannot be observed directly, because they neither emit nor reflect light, their presence can be inferred from the effects of their gravitational fields on nearby stars and other matter. For example, if a binary star consists of two stars, one visible and the other a black hole, the motion of the visible star indicates the presence of its partner. Astronomers have found several good candidates for this type of black hole. Many other observations suggest the presence of black holes.

### The discovery of gravity waves

In the February 12, 2016, edition of *Physical Review Letters*, an article was published announcing the discovery of gravity



**Figure 20.23** The gravitational effects of a black hole can be represented by a strong curvature of space near the black hole.

waves. The existence of gravity waves had been predicted by Einstein almost 100 years earlier as part of his theory of general relativity, but they were expected to be extremely weak and difficult to detect. Physicists had been searching for them ever since.

The experiment that detected gravity waves was started in 1993. It involved two Michelson interferometers (see fig. 20.9), one in Hanford, Washington, and the other in Livingston, Louisiana. The interferometers at each site consisted of two very long arms (4 km in length) at right angles to one another that bounced laser beams between mirrors on each arm and then recombined the beams to form interference patterns. (See section 16.3 on light interference.)

In September of 2015, the two interferometers in Washington and Louisiana detected almost identical interference patterns, indicating that gravity waves had come in from outer space. (Two interferometers at widely spaced locations were needed to exclude the possibility that the waves had come from more local effects.) Actually, the observed signal arrived at the Louisiana site 7 milliseconds (0.007 s) before the one in Washington, which indicated that the waves came from the southern hemisphere of astronomical objects as viewed from Earth.

Analysis of the data suggested that the waves were created by the collision or merger of two black holes in a very distant galaxy. These black holes were estimated to be 1.3 billion light-years from Earth, so it took 1.3 billion years for the waves traveling at the speed of light to reach Earth after the event. The discovery of the waves created tremendous excitement in the astrophysics community, because it provides a new way of studying distant events in the universe.

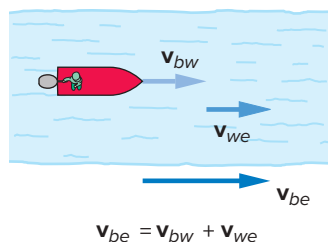
Einstein's theories of special and general relativity have had an enormous impact on modern physics. The predicted effects are well confirmed, from the energy released in nuclear reactions to astronomical effects such as the bending of starlight. Our fundamental conceptions of space and time have been modified and intermixed by these ideas. Although removed from everyday experience, these ideas certainly excite the imagination.

While Einstein's special theory of relativity is primarily concerned with inertial frames of reference, his general theory of relativity treats accelerated frames of reference. The additional basic postulate of general relativity is the principle of equivalence, which states that we cannot distinguish the acceleration of a frame of reference from the effects of a gravitational field. General relativity predicts the bending of light by a strong gravitational field, the slowing of clocks in accelerated reference frames or gravitational fields, and the curvature of space-time produced by gravitational effects. The concept of black holes emerged from these ideas. The study of general relativity and the nature of gravity remains an active area of research.

## Summary

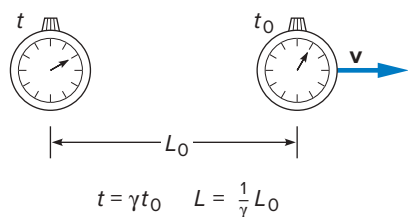
The velocity of light apparently does not add to the velocity of the source or frame of reference in the way that ordinary velocities do in classical mechanics. This idea led Einstein to a radical new way of looking at the nature of space and time. We have described the basic postulates of Einstein's special and general theories of relativity in this chapter and explored some of the consequences of accepting these postulates.

**1 Relative motion in classical physics.** If an object is moving relative to a frame of reference (such as a stream) that is itself moving, classical mechanics predicts that the velocities of these motions will add as vectors. Newton's laws are valid in any inertial frame of reference, which are frames that are not accelerated relative to other inertial frames.

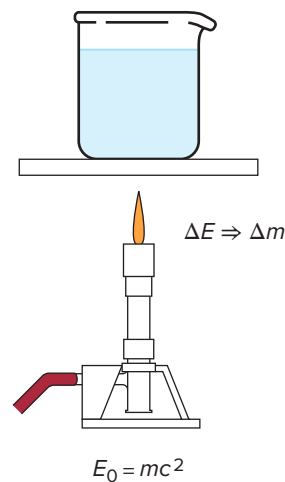


**2 The speed of light and Einstein's postulates.** The failure of experiments to detect any motion of the ether (the supposed medium for light waves) relative to the Earth started a debate that ultimately led to Einstein's two basic postulates of special relativity: First, the laws of physics have the same form in any inertial frame of reference (the principle of relativity), and second, the speed of light is the same in any inertial frame of reference, regardless of the motion of the source.

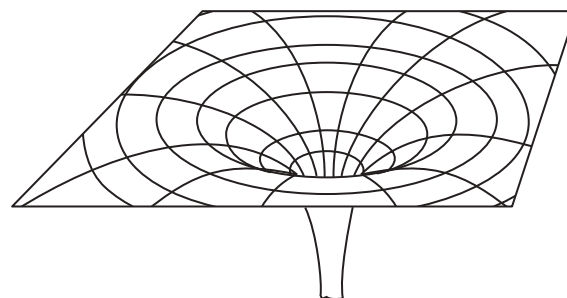
**3 Time dilation and length contraction.** Application of Einstein's postulates to the measurement of time and length shows that observers in different frames of reference will not agree on these measurements. A person observing a moving clock will see a longer (dilated) time than the time measured by an observer for whom the clock is at rest. An observer measuring a moving length will observe a shorter (contracted) length than the rest length.



**4 Newton's laws and mass-energy equivalence.** Extending these ideas to dynamics, Einstein found that Newton's second law of motion could be preserved only if we redefined momentum and used the general form of Newton's second law written in terms of momentum. A computation of kinetic energy then led to the recognition that mass is equivalent to energy.



**5 General relativity.** Special relativity is primarily concerned with inertial frames of reference. Accelerated frames of reference and gravity are treated in general relativity. The basic new postulate of general relativity is the principle of equivalence: An acceleration of a frame of reference cannot be distinguished from the presence of a gravitational field. This additional postulate leads to new effects involving the bending of light and the modification of time by gravitational fields. It also requires the use of non-Euclidean, curved-space geometries to describe the space-time continuum.



The study hints in Connect give a concise and thorough summary of the chapter. You might find this a helpful way to review the new and fascinating ideas discussed in this chapter.

## Key Terms

Frame of reference, 435	Light clock, 442	Principle of equivalence, 450
Special theory of relativity, 435	Proper time, 443	Gravitational red shift, 451
General theory of relativity, 435	Rest length, 444	Space-time continuum, 452
Principle of relativity, 438	Rest energy, 447	Black hole, 452

## Conceptual Questions

\* = more open-ended questions, requiring lengthier responses, suitable for group discussion

Q = sample responses are available in appendix D

Q = sample responses are available in Connect

- Q1. If a boat is moving downstream, will the velocity of the boat relative to the water be greater than the velocity of the boat relative to the stream bank? Explain.
- Q2. If a boat is moving upstream, will the velocity of the boat relative to the bank of the stream be greater than the velocity of the boat relative to the water? Explain.
- Q3. If an airplane is flying in the same direction as the wind, will the velocity of the plane relative to the ground be greater than, less than, or equal to the velocity of the plane relative to the air? Explain.
- Q4. Is it possible that a person in a rowboat will not be able to move upstream? Explain.
- Q5. If a boat is moving across a stream, will the speed of the boat relative to the bank equal the numerical sum of the speed of the boat relative to the water and the speed of the water relative to the bank? Explain.
- Q6. If an airplane is flying in a crosswind blowing at an angle of  $90^\circ$  to the direction the airplane is pointed, will the speed of the plane relative to the ground be less than the speed of the plane relative to the air?
- Q7. Does the addition of the velocities of things such as airplanes and wind speed require use of the special theory of relativity? Explain.
- \*Q8. Would it be appropriate, from the perspective of special relativity, to add the velocity of light relative to the Earth to the velocity of the Earth relative to the sun to obtain the velocity of light relative to the sun? Explain.
- Q9. Was the ether (the assumed medium for light waves) presumed to exist in a vacuum? Explain.
- \*Q10. What was the Michelson-Morley experiment designed to detect? Why did they expect that the speed of light might vary at different times of the year? Explain.
- Q11. Did the Michelson-Morley experiment succeed in measuring the velocity of the ether relative to the Earth? Explain.
- Q12. Do either of Einstein's postulates contradict the classical assumptions of how relative velocities add? Explain.
- Q13. Which of Einstein's postulates deals most directly with the failure to detect motion of the Earth relative to the ether? Explain.
- Q14. Is it possible that two different observers will not agree on the time taken for a light beam to bounce off a mirror and return to its source? Explain.
- Q15. A chess game taking place on Earth is seen by Observer A, who is passing by in a spaceship. Observer B is standing on Earth, looking over the shoulder of the players. Which of these two observers measures the longer time for the interval between moves in the game? Explain.
- Q16. A radioactive isotope with a certain half-life is moving with a high speed in a particle accelerator. Does an observer at rest in the lab measure the proper time for the half-life of this isotope? Explain.
- Q17. A spaceship is moving with a large velocity past Observer A, who is standing on Earth. Observer B is aboard the spaceship. Which of these observers measures the longer length for the length of the spaceship? Explain.
- \*Q18. Is it theoretically possible for a father to be younger (to have aged less) than his son or daughter? Explain. (See everyday phenomenon box 20.1.)
- \*Q19. Is it possible for an astronaut to leave on a space trip and return a year before her twin sister was born? Explain. (See everyday phenomenon box 20.1.)
- Q20. Is Newton's second law, written in the form  $\mathbf{F}_{\text{net}} = m\mathbf{a}$ , valid for objects traveling at velocities near the velocity of light? Explain.
- Q21. Could we use the relativistic momentum expression,  $\mathbf{p} = \gamma m\mathbf{v}$ , for objects moving at small velocities? Explain.
- Q22. If we compress a spring and lock it into its newly compressed configuration, have we changed the mass of the spring? Explain.
- Q23. Is the increase in kinetic energy of an object equal to the work done to accelerate the object for an object moving at a very high speed? Explain.
- \*Q24. Is it completely correct to say that mass is converted into energy in a nuclear reaction, such as a fission reaction? Explain.
- Q25. If the velocity of an object is reduced to zero, does all of its energy disappear? Explain.
- Q26. If an elevator is accelerating downward, will your apparent weight (as measured by a bathroom scale) be greater than your weight measured when the elevator is not accelerating? Explain.
- Q27. When you are inside a closed space vehicle, is it possible for you to tell whether (a) the vehicle is accelerating or

(b) you are simply near some massive body, such as the sun or the Earth? Explain.

- Q28. Would your experiences inside a freely falling elevator be similar in any way to those inside a spaceship moving with constant velocity when it is a long distance away from any planet or star? Explain.

Q29. Does light traveling in empty space always travel in a straight line? Explain.

- Q30. Is a black hole just a hole in space that contains no mass? Explain.

## Exercises

- E1. A boat that can travel with a velocity of 12 m/s in still water is moving at maximum speed *against* the current (therefore upstream) of a stream that flows with a velocity of 5 m/s relative to the Earth. What is the velocity of the boat relative to the bank of the stream?
- E2. A plane that can travel at 550 MPH in still air is flying with a tailwind of 40 MPH. How long does it take for the plane to travel a distance of 1700 miles (relative to the Earth)?
- E3. A swimmer swims upstream with a velocity of 2.8 m/s relative to the water. The velocity of the current is 1.5 m/s (downstream). What is the velocity of the swimmer relative to the bank?
- E4. A ball is thrown with a velocity of 35 MPH down the aisle (toward the tail of the plane) of a jetliner traveling with a velocity of 400 MPH relative to the Earth. What is the velocity of the ball relative to the Earth?
- E5. An astronaut aims a flashlight toward the tail of his spaceship, which is traveling with a velocity of  $0.6c$  relative to the Earth. What is the velocity of the light beam relative to the Earth?
- E6. The factor  $\gamma = 1/\sqrt{1 - (v^2/c^2)}$  appears in many expressions derived from the theory of special relativity. Show that  $\gamma = 1.40$  when  $v = 0.7c$ .
- E7. An astronaut cooks a 3-minute egg in his spaceship whizzing past Earth at a speed of  $0.8c$ . How long has the egg cooked, as measured by an observer on Earth? (See table 20.1.)
- E8. An observer on Earth notes that an astronaut on a spaceship puts in a 5-hour shift at the controls of the spaceship. How long is this shift, as measured by the astronaut himself, if the spaceship is moving with a velocity of  $0.9c$  relative to the Earth? (See table 20.1. Be careful in reaching your answer. Keep in mind which observer measures the proper time.)
- E9. A spaceship that is 70 m long, as measured by its occupants, is traveling at a speed of  $0.3c$  relative to the Earth. How long is the spaceship, as measured by mission control in Houston? (See table 20.1.)
- E10. The crew of a spaceship traveling with a velocity of  $0.6c$  relative to the Earth measures the distance between two cities on Earth (in a direction parallel to their motion) as 700 km. What is the distance between these two cities, as measured by people on Earth? (See table 20.1. Which observer measures the rest length?)
- E11. A spaceship is traveling with a velocity of  $0.5c$  relative to the Earth. What is the momentum of the spaceship if its mass is 8000 kg? ( $p = \gamma mv$  and  $c = 3 \times 10^8$  m/s. See table 20.1.)
- E12. Suppose an object has a mass-energy of 900 joules when it is at rest.
- What is its total energy when it is moving with a velocity of  $0.8c$ ? ( $E = \gamma E_0$ . See table 20.1.)
  - What is the kinetic energy of the object at this speed? ( $KE = E - E_0$ )

## Synthesis Problems

- SP1. A boat capable of moving with a velocity of 7 m/s relative to the water is pointed straight across a stream flowing with a current velocity of 3 m/s. The width of the stream is 28 m.
- Draw a vector diagram to show how the velocity of the stream adds to the velocity of the boat relative to the water. Use this to obtain the velocity of the boat relative to the Earth.
  - Use the Pythagorean theorem to find the magnitude of the velocity of the boat relative to the Earth.
  - How long does it take for the boat to cross the stream? (*Hint:* We need to consider only the component of the velocity of the boat that is straight across the stream if we use the stream width for the distance.)
  - How far downstream from its starting point does it hit the opposite bank? (*Hint:* We need to consider only the component of the velocity of the boat that is parallel to the bank.)
  - Use the Pythagorean theorem to find how far the boat actually travels in reaching the opposite bank.
- SP2. Suppose that a beam of  $\pi$ -mesons (or pions) is moving with a velocity of  $0.96c$  with respect to the laboratory. When the pions are at rest, they decay with a half-life of  $1.77 \times 10^{-8}$  s.
- Calculate the factor  $\gamma$  for the velocity of the pions relative to the laboratory.
  - What is the half-life of the moving pions, as seen by an observer in the laboratory?
  - How far do the pions travel, as measured in the laboratory, before half have decayed?
  - What is the distance found in part c, as viewed from the frame of reference of the pion?
- SP3. Suppose an astronaut travels to a distant star and returns to Earth. Except for brief intervals of time when he is accelerating or decelerating, his spaceship travels at the incredible speed of  $v = 0.995c$  relative to the Earth. The star is 46 light-years away. (A light-year is the distance light travels in 1 year.)
- Show that the factor  $\gamma$  for this velocity is approximately equal to 10.

- b. How long does the trip to the star and back take, as seen by an observer on Earth?
- c. How long does the trip take, as measured by the astronaut?
- d. What is the distance traveled, as measured by the astronaut?
- e. If the astronaut left a twin brother at home on Earth while he made this trip, how much younger is the astronaut than his twin when he returns?

SP4. Suppose a beaker contains 2.5 kg (2500 g) of water. Heat is added to the water to raise its temperature from 0°C to 100°C.

- a. How much heat energy in joules must be added to the water to raise its temperature? ( $c_w = 1 \text{ cal/g}\cdot\text{C}^\circ$  and  $1 \text{ cal} = 4.186 \text{ J}$ . See section 10.2 if you need to be reminded how to calculate the heat energy.)
- b. By how much does the mass of the water increase in this process? ( $E_0 = mc^2$ )
- c. Compare this mass increase to the original mass of the water. Would this increase in mass be measurable?
- d. If it were somehow possible to convert the original mass of the water into kinetic energy, how many joules of kinetic energy could be produced?

SP5. Using the diagram in figure 20.13, derive the time-dilation formula. The steps are as follows:

- a. From the symmetry of the diagram, we assume that the total time measured by the Earth observer is twice the time required to reach the mirror.
- b. Using the right triangle shown in the diagram and the Pythagorean theorem, we can write

$$c^2 \left(\frac{t}{2}\right)^2 = d^2 + v^2 \left(\frac{t}{2}\right)^2$$

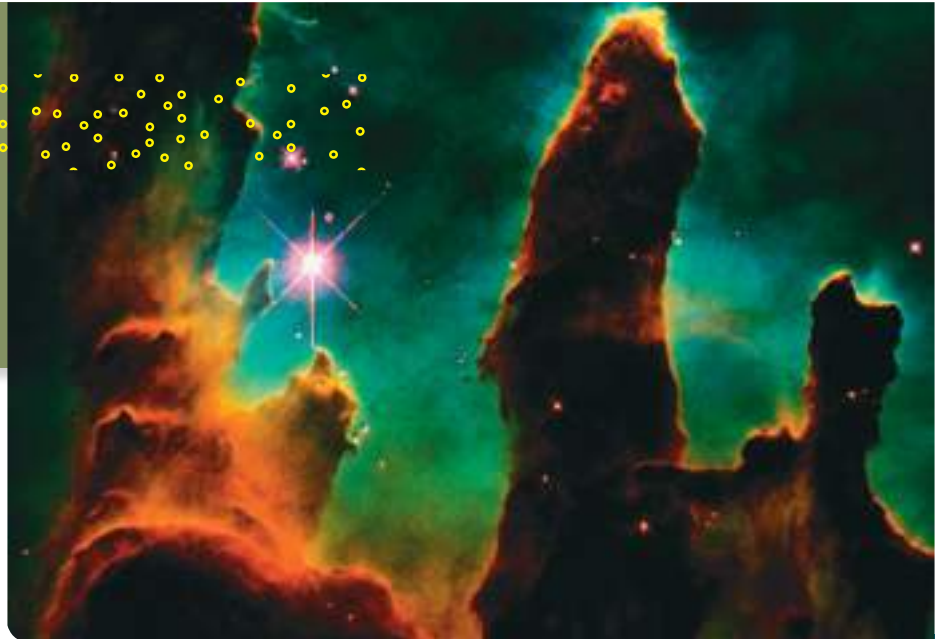
- c. Grouping terms containing  $t$  on one side of the equation and taking the square root of both sides, we can solve this expression for the time  $t$  measured by the Earth observer.
- d. Because the quantity  $2d/c$  is the time measured by the spaceship pilot  $t_0$ , this expression reduces to the time-dilation formula introduced in section 20.3.

## Home Experiments and Observations

HE1. If you have access to a small, smooth-flowing stream, you can test the velocity-addition ideas in the first section of this chapter. A small, battery-powered or wind-up boat is also necessary. These can be found in toy or variety stores.

- a. Test your boat first in the bathtub or a pond to estimate how fast it can move in still water.
- b. Find a place in the stream where the current is slow and smooth (no eddies). Drop a twig in the stream, and with the help of a watch, estimate the velocity of the current.

- c. Place your boat, with its motor running, in the stream with the boat pointed downstream. Estimate its velocity relative to the bank. Does the result agree with what you would predict, based on the addition of relative velocities?
- d. Will the boat move upstream? (If the current is too strong, it may be difficult to keep it headed in this direction.)
- e. Try pointing the boat across stream in a location where the current is as uniform as possible. What do you have to do to get the boat to cross the stream?



Source: NASA, ESA, STScI, J. Hester and P. Scowen (Arizona State University)

## Looking Deeper into Everyday Phenomena

### Chapter Overview

In day-to-day life, we're usually unaware of the vast goings-on in the world around us, or even within us. One benefit of learning physics is an expanded awareness of our connection to things hidden from view—things without which we couldn't exist. This chapter delves into a few broad areas of research in physics that expand our awareness in this way, extending from the very small to the very large. The ideas discussed include elementary particles, the overall structure and history of our universe, semiconductor electronics, and superconductors and other exotic materials. These areas of research are examined because they have excited the popular imagination or are likely to have a significant impact on developing technologies. The descriptions are necessarily brief—the objective is to emphasize the fundamental ideas and issues, giving you a foundation for learning more about topics that interest you.

### Chapter Outline

- 1 Quarks and other elementary particles.** What are the basic building blocks of the universe? How do current theories organize and classify the elementary particles?
- 2 Cosmology: Looking out into the universe.** When did our universe begin, and how is it changing over time? How do our studies of elementary particles shed light on the early history of the universe?
- 3 Semiconductors and microelectronics.** What are transistors, and how do they work? How have semiconductor devices revolutionized the electronics industry?
- 4 Superconductors and other new materials.** What are superconductors? What other new materials are emerging from the study of solid-state physics?

One of the most intriguing aspects of science is that we can never be sure just where it will lead us. Like a good mystery, there are clues and indications, but the answers are elusive. Unlike a mystery novel, there is no final resolution. Successes in science increase our understanding of nature and often lead to advances in technology, but they always raise new questions.

Physics most often makes the news when it overlaps with social and political issues. Questions are raised about spending several billion dollars to build a new particle accelerator or space telescope, and ordinary citizens are sometimes called on to make judgments about such issues. The construction of the James Webb Space Telescope is a multiyear process that has periodically come under congressional scrutiny (fig. 21.1).

Our everyday lives are impacted in more ways than we realize by advances in physics. Most of us use personal computers and electronic devices, like cell phones, that have microcomputers built into them. Computers have brought about enormous changes in the way we live, work, and play. The invention of the transistor, which made the modern computer feasible, came about through advances in solid-state physics and our understanding of semiconductors.

Modern physics is active on many fronts. Some research areas are driven by the need to make improvements in technology, while others are motivated simply by a desire to better understand the universe in which we live. Although this chapter



**Figure 21.1** The James Webb Space Telescope will complement and extend the discoveries of the Hubble Space Telescope. The anticipated launch date is October 2021. In this photo, NASA technicians lift the mirror for the telescope using a crane and move it inside a clean room at NASA's Goddard Space Flight Center in Greenbelt, Maryland.

Source: NASA/Desiree Stover

cannot touch on all of these areas, we will examine a few that have received public attention and are likely to continue to do so. Ideas that seem well removed from common experience today may someday become part of everyday technology.

## 21.1 Quarks and Other Elementary Particles

One of the most enduring quests in science is the search for the building blocks of nature, the particles or entities from which everything else is constructed. Until the twentieth century, these building blocks were thought to be atoms, a view strengthened by the advances in chemistry during the nineteenth century (see chapter 18). In fact, the word *atom* comes from the Greek *atomos*, meaning indivisible.

As we discussed in chapter 18, experiments beginning in the late 1800s revealed that atoms are divisible after all. The discovery of the electron by J. J. Thomson in 1897 revealed the first subatomic particle. This advance was followed in 1911 by the discovery of the nucleus of the atom and by the later recognition that nuclei are themselves made up of protons and neutrons. We are now aware that protons and neutrons also have a substructure—they are composed of quarks (fig. 21.2).

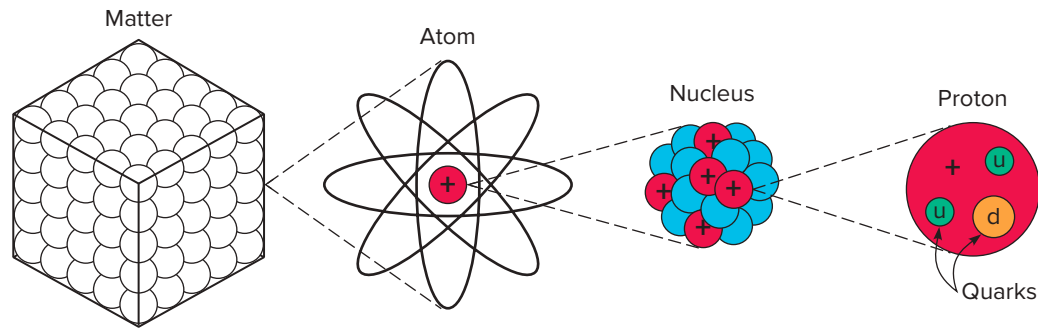
Where will this all end? What are quarks and why do we believe they exist? Will we someday discover that quarks also have a substructure? This final question cannot be answered with certainty, but recent advances in our theoretical understanding of high-energy physics have brought order to

what seemed like a bewildering array of new particles. We will consider just a few features of this new theory, often called the **standard model**.

### How are new particles discovered?

The electron, proton, and neutron, the basic constituents of the atom, were just the first in a long parade of subatomic particles discovered in the twentieth century. The **positron**, for example, was discovered in 1932 shortly after its existence was suggested on theoretical grounds by British physicist Paul Dirac (1902–1984). This discovery was followed by the discovery of the **muon** and **pion**. The list grew rapidly during the 1950s and 1960s as work in high-energy physics intensified.

How are these discoveries made? Most of them involve scattering experiments, similar to those performed by Rutherford and his associates. (See section 18.3.) Targets are bombarded with fast-moving particles, and particle detectors are used to study what emerges from these collisions. The emerging particles leave tracks in the photographic emulsions, cloud chambers, and bubble chambers that were used in early experiments and in other, more sophisticated detectors in use today. In cloud



**Figure 21.2** Atoms, once thought to be the basic building blocks of all matter, are now known to consist of electrons, protons, and neutrons. Neutrons and protons also have a substructure made of quarks.



**Figure 21.3** Particle tracks in a bubble chamber (or in modern electronic detectors) provide information on the new particles produced in collisions and decays.  
*Zmeel Photography/E+/Getty Images*

chambers and bubble chambers, a rapidly moving charged particle creates water droplets or bubbles in a supersaturated vapor or superheated fluid (fig. 21.3).

Analyses of these tracks, along with other measurements, allow us to deduce the mass, kinetic energy, and charge of the particles created in the collisions. The path of a positively charged particle, for example, bends one way in a magnetic field, and the path of a negatively charged particle bends in the opposite direction. The degree of curvature of the path is related to the mass of the particle. The mass is particularly important—it is one of the major identifying characteristics of the particles.

The source of high-energy particles in these scattering experiments is usually a particle accelerator. Rutherford used alpha particles from radioactive substances, but the alpha particles have limited energies. Other early workers used the high-energy particles in *cosmic rays* that stream in from outer space. (Some of these particles from outer space are streaming through you right now, unnoticed.) Particle accelerators, however, are capable of producing both

high-energy and high-density beams of particles, which make interesting collisions more likely.

A modern particle accelerator uses electric and magnetic fields to accelerate and shape the beam. The beam itself is contained in a long evacuated tube that can be either straight (as in a linear accelerator) or bent into a large ring. Two beams of particles can be made to collide head-on at the point where the reactions are studied, providing a larger collision energy than from collisions with a stationary target. Beam energies are typically measured in electron volts (eV). Because mass is a form of energy, producing particles with masses much larger than the proton or neutron requires very high collision energies, which has prompted the building of ever-bigger particle accelerators. Modern accelerators are capable of reaching collision energies up to 1000 GeV or more (1 GeV is 1 billion eV, roughly the energy equivalent to the mass of a proton). The largest modern accelerators now operating include the Stanford Linear Accelerator Center (SLAC) in California, the Fermilab proton-antiproton collider near Chicago, and the Large Hadron Collider (LHC) at CERN in Switzerland/France, which holds the record of over 1000 GeV.\*

### Denizens of the particle zoo

As more and more particles were discovered, scientists tried to organize and classify them, guided by theoretical considerations. Although the models were often incomplete, they were sometimes successful in predicting the existence of new particles later discovered experimentally. (This is similar to the way the structure of the periodic table in chemistry helped predict new elements.) The original classification schemes were based primarily on the masses of the particles.

The particles were placed into three primary groups: leptons, mesons, and baryons. **Leptons** are the lightest

\*To learn more about the LHC in the form of a rap video, see <http://www.youtube.com/watch?v=j50ZssEojtM> or just google “LHC rap.”



particles and include electrons, positrons, and the neutrinos involved in beta decay. **Mesons** are intermediate in mass and include the pion (originally called the  $\pi$ -meson) and the kaon. **Baryons** are the heaviest—they include the neutron and proton, as well as many heavier particles.

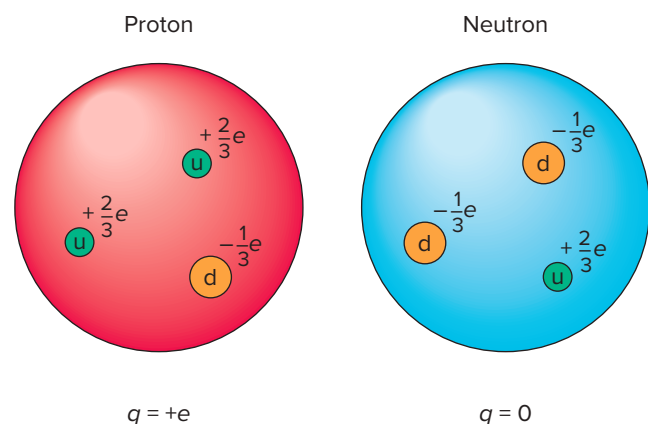
Each particle has an antiparticle, which has the same mass as the particle but opposite values of other properties, such as charge. The positron, for example, is the antiparticle of the electron and has a positive charge instead of a negative charge. When a particle runs into its antiparticle, the two can annihilate each other, producing high-energy photons or other particles.

### What are quarks?

*Quantum electrodynamics* and *quantum chromodynamics*, based on both quantum mechanics and relativity, are the theories that describe the interactions between elementary particles. Advances in these theories in the early 1970s suggested a more fundamental organization scheme for all of these particles, and this is where **quarks** come into the picture. Mesons and baryons (which together are now called **hadrons**) are all made up of quarks: new particles suggested by these theories. Each meson consists of two quarks—a quark and an antiquark—and baryons are groups of three quarks.

As the theories developed, it became evident that six types of quark are necessary (not counting the antiparticles) to account for all of the baryons and mesons. These have been dubbed the *up*, *down*, *charmed*, *strange*, *top*, and *bottom* quarks. (Clearly, physicists have a sense of humor.) Different combinations of these six quarks (and their antiparticles) account for all of the observed particles in the meson and baryon groups.

The proton consists of three quarks: two up quarks each of charge  $+\frac{2}{3}e$  and one down quark of charge  $-\frac{1}{3}e$ . A neutron is made of two down quarks and one up quark, for a total charge of zero (fig. 21.4). Scattering experiments in which extremely high-energy electrons are collided with protons



**Figure 21.4** A proton consists of two up quarks and one down quark. A neutron consists of two down quarks and one up quark.

**Table 21.1**

The Three Families of Elementary Particles		
First Family	Second Family	Third Family
Electron	Muon	Tau particle
Electron neutrino	Muon neutrino	Tau neutrino
Up quark	Charmed quark	Top quark
Down quark	Strange quark	Bottom quark

provide strong evidence for this substructure. These experiments indicate the presence of hard scattering centers within the proton, with the appropriate charges for two up quarks and one down quark. The analysis is similar to Rutherford's discovery of the nucleus (chapter 18).

There are also similarities among the groups of leptons and quarks. These particles are grouped into three families with similar properties. Each family consists of two leptons and two quarks, and one of the leptons in each family is a neutrino. Table 21.1 shows the particles that belong to each family. In this scheme, there are just 12 elementary particles (three families of 4 particles each), or 24, counting the antiparticles.

With the detection of the tau neutrino, which was announced on July 21, 2005, all 12 of these particles have now been confirmed experimentally. An international collaboration of 54 physicists at Fermilab in Illinois made the discovery of the tau neutrino after a three-year analysis of data from the Direct Observation of the Nu Tau (DONUT) experiment.

Quarks are never present individually but always in combination with other quarks. For this reason, they cannot be directly observed as tracks in a particle detector. Their existence can be inferred, however, by scattering experiments and by observing reactions that are predicted by the quark model. High particle energies and beam densities are required to enhance the probability of observing such reactions. Refinements in accelerators have continued to produce advances. The LHC at CERN will likely provide the conditions for new discoveries over the next few years.

A huge stir was created in the physics community by the experimental confirmation of the existence of the Higgs boson. The Higgs boson was first predicted in 1964, and it was needed to make the standard model complete. Its postulated role was to mediate the interaction between quarks and other particles and to thereby give them their mass. For a number of reasons, though, it is extremely difficult to detect the Higgs boson, because it exists for only very short times and requires large energies for its production, and we did not know its mass. Experiments done in 2012 and 2013 at the Large Hadron Collider, as well as at Fermi Lab in the United States, have finally resulted in firm evidence for the existence of the Higgs boson and the approximate determination of its mass. Other discoveries regarding the features of the

Higgs boson, and even perhaps the existence of more than one type of Higgs boson, are likely to be the result of some of the ongoing work.

### What are the fundamental forces?

What holds all of these particles together? The primary force responsible for binding the quarks in neutrons, protons, and other baryons (as well as mesons) is the **strong nuclear interaction**. This force also binds the neutrons and protons inside the nucleus of an atom and must be stronger than the electrostatic repulsion of the positively charged protons to keep the nucleus from flying apart. The strong nuclear interaction has a very short range, however, and decreases rapidly at distances greater than nuclear dimensions.

In addition to the strong nuclear interaction, physicists have recognized three other fundamental forces—the electromagnetic force (see chapter 12), the gravitational force (see chapter 4), and the weak nuclear force. The **weak nuclear force** is involved in the interactions of leptons: The process of beta decay, which involves electrons and neutrinos, is an example. One of the goals of theoretical physics has been to unify all of these forces with a single theory. Because we usually describe these forces in terms of their fields, as we have done with electric and magnetic fields, such a theory is referred to as a **unified field theory**.

One of the major successes of the standard model of particle physics is that it has unified the weak nuclear force with the electromagnetic force. These two forces can now be viewed as different manifestations of the same fundamental force: the **electroweak force**. James Clerk Maxwell’s theory of electromagnetism had unified two seemingly independent forces—the electric force and the magnetic force—into the electromagnetic force. Now that force has been joined with the weak nuclear force.

Perhaps we should say that there are only three fundamental forces, the strong nuclear interaction, the electroweak force, and the gravitational force. This statement may also be misleading, because substantial progress has been made toward unifying the strong nuclear interaction with the

electroweak interaction in extensions of the standard model (fig. 21.5). These theories are now referred to as **grand unified theories**, or GUTs for short.

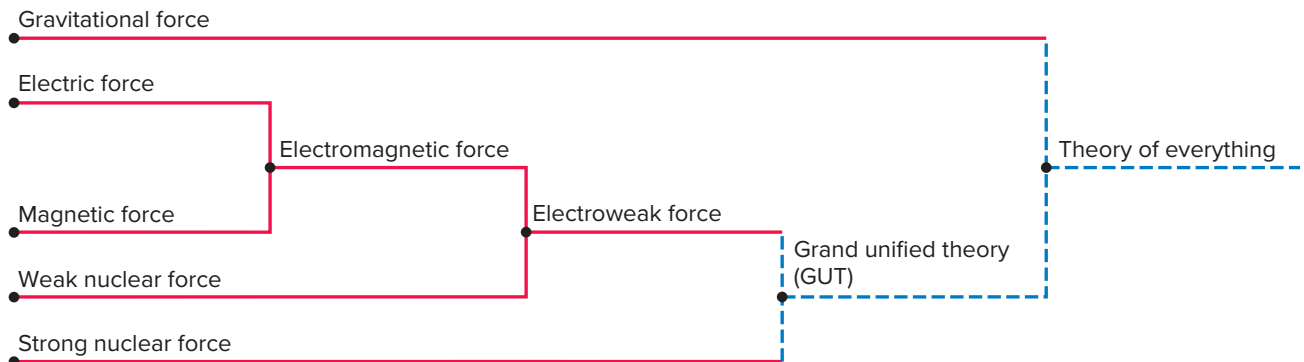
One force, the gravitational force, has thus far resisted incorporation into a unified field theory. Gravity’s theoretical basis is found in Einstein’s theory of general relativity, but the mathematics of general relativity seem to be incompatible in some ways with quantum mechanics and the standard model. Fame and honor await those who succeed in unifying the gravitational force with the other fundamental forces in a *theory of everything*. String theory, a multidimensional model that incorporates gravity, is a possible candidate, but it has not yet been possible to test it experimentally.

Scattering experiments performed at ever-higher energies have uncovered an array of subatomic particles. The standard model has succeeded in organizing these particles into three families, each with two leptons and two quarks (and their antiparticles). This model predicted the existence of new particles, including the top quark. Theoreticians continue to strive for a unified theory that will encompass all of the fundamental forces.

## 21.2 Cosmology: Looking Out into the Universe

Section 21.1 gave us a glimpse into the physics of the very small—the building blocks for all the ordinary matter of our world. What happens if we shift our focus to the very large? Our Earth is part of the solar system (see chapter 5). The sun is one of seemingly countless stars grouped into galaxies, which themselves come in clusters. What is the large-scale structure of our universe, and how is it changing?

**Cosmology** is the branch of physics and astronomy that investigates these kinds of questions. Ironically, answers to



**Figure 21.5** Fundamental forces of nature once viewed as independent forces have been unified into fewer fundamental forces by advances in theoretical understanding. Complete unification of all fundamental forces may lie ahead.



**Figure 21.6** A spiral galaxy viewed against a foreground of nearer stars. Our own Milky Way galaxy has a similar shape.  
NASA/JPL-Caltech/S. Willner (Harvard-Smithsonian Center for Astrophysics)

questions about the very big may be related to our knowledge of the very small, at the scale of particles such as atoms, nuclei, quarks and perhaps even smaller.

### Is the universe expanding?

Humans have long been fascinated by the night sky and by questions about the nature of the universe as a whole. Nearly every culture we know about has had a story describing the origin and overall nature of the universe and humanity's place within it. The invention of the telescope around 1600 provided a new instrument for viewing the planets and stars and learning about the universe. Using a crude telescope, Galileo discovered the moons of Jupiter and the phases of Venus, and that helped to turn the tide in favor of the Copernican heliocentric model of the solar system (see chapter 5).

As telescopes improved, observers of the heavens became aware of many more objects out there than those visible to the unaided eye. Not all of these objects appeared to be pointlike stars. Some had a fuzzy appearance, and as the resolution of telescopes increased, it became obvious that some of them were not single stars at all but collections of stars, what we now call **galaxies**. Many galaxies have a spiral structure like the one shown in figure 21.6.

The galaxy we see most readily with unaided eyes is our own, the Milky Way. On a clear night, the Milky Way is visible as what appears to be a continuous cloud of stars forming a band across the sky (fig. 21.7). We see this band because we are actually *inside* the disk of a spiral galaxy similar to the one shown in figure 21.6. When we look along a line of sight that goes through the disk, we see stars piled upon stars, producing the cloudy band (a telescope or even binoculars resolves the cloud into a multitude of individual stars). Our sun is one of several hundred billion stars that make up the Milky Way galaxy. The Milky Way is already so large that it takes light about 100,000 years to travel from one side of the visible disk to the



**Figure 21.7** Because we are inside the disk of our own galaxy, the Milky Way appears as a continuous cloud of stars that can be seen as a band across the sky on a clear night.  
Basti Hansen/Shutterstock

other. But our galaxy is itself just one of many billions of galaxies in the observable universe (fig. 21.8).

Observations of other galaxies beginning in the early twentieth century revealed one of the great surprises in the history of science. Except for a few very nearby ones, *all the galaxies are moving away from us!* What's more, the *farther away* a



**Figure 21.8** This photo, taken with the Hubble Space Telescope, covers a tiny region of the sky, only about a tenth as wide as the full moon. However, it contains thousands of galaxies, each containing hundreds of billions of stars. Imagine having eyes sensitive enough to see with the same depth over the whole sky, and you begin to get a sense of the vastness of the universe.  
NASA/ESA/S. Beckwith (STScI) and the HUDF Team

galaxy is, the *faster* it is moving away from us. This realization emerged from a synthesis of galaxy observations by American astronomer Edwin Hubble (1889–1953) in the 1920s, building on the work of Henrietta Leavitt (1868–1921), Vesto Slipher (1875–1969), Milton Humason (1891–1972), and others. These astronomers were trying to determine two key properties of galaxies: their distances from us and their velocities relative to us.

Distances to galaxies are measured using an extension of a very familiar, everyday principle: All else being equal, the farther away a light source is from your eyes, the fainter it appears to you. An airplane landing light is unpleasantly bright when shining in your face from a few feet away. But when that airplane light is far away in the sky, it's so faint that it might be temporarily mistaken for a star or planet. This principle allows astronomers to estimate distances to stars and galaxies by measuring their brightness.

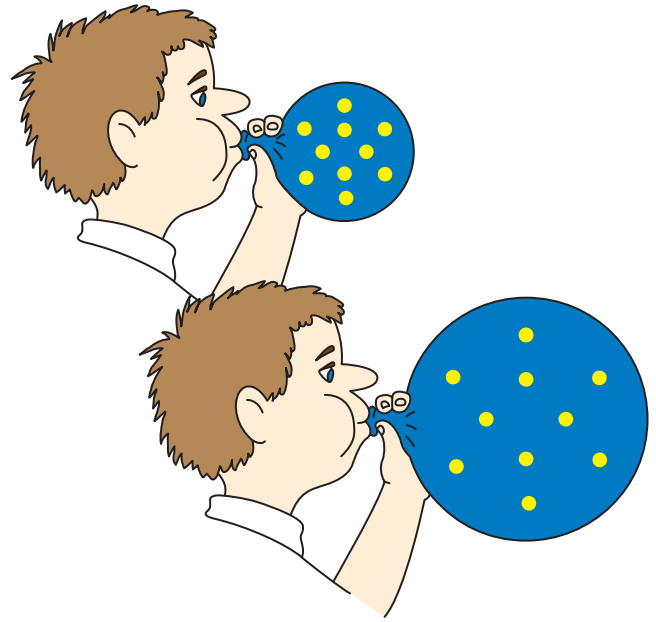
The catch is that the technique only works if you know the **luminosity** of the object you're looking at. A faint spot of light in the sky might be a very nearby firefly or a very distant galaxy shining with the light of hundreds of billions of suns. It would be nice if stars were like lightbulbs, with the wattage (100 watts or 60 watts, for example), clearly stamped on them.

Remarkably, some stars *do* display their wattage, if you know how to interpret them. Henrietta Leavitt discovered an important class of these stars, called *Cepheid* variables. These stars vary in brightness over time, and it turns out that their period of variation (how long it takes to go from bright to dim and back to bright) is related to their luminosity. Thus, if you watch one of these stars over several months and determine its period, you can learn its luminosity, and hence its distance. Because Cepheids are very bright and are visible in some other galaxies, Leavitt's work provided a cornerstone for measuring distances to galaxies outside our own Milky Way.

The measurement of galaxy velocities, pioneered by Vesto Slipher, also relies on the application of familiar principles: the Doppler effect you learned about in everyday phenomenon box 15.2 and the wave nature of light, discussed in chapter 16. Slipher and others observed that specific *absorption lines* in the spectra of stars in other galaxies were all shifted in wavelength and frequency toward the red portion of the spectrum. (Absorption lines make good reference points in the otherwise continuous spectrum of stars. They are produced by the absorption of light at specific wavelengths by gases in the outer portions of the star.)

The red shift implies that these stars must be moving away from us, producing a Doppler shift in the frequency of the light. Recall from chapter 15 that the frequency of sound waves from a car horn is shifted to a lower value when the car is moving away from us. For light, a lower frequency is a shift toward the red end of the visible spectrum.

Hubble and Humason combined the distance and velocity measurements of other astronomers with some of their own, to reach the startling conclusion that the farther away a galaxy is, the more swiftly it recedes from us. This conclusion was described in a famous 1929 paper and is now known as



**Figure 21.9** As the balloon is inflated, coins on the surface recede from one another. Coins that are initially farther away from some chosen point recede more rapidly from that point than do nearer coins.

the *Hubble law*. It was a key discovery leading to the realization that the entire universe is expanding, a conclusion that, in retrospect, was also suggested by Einstein's theory of general relativity (section 20.5).

From our knowledge of the curvature of space-time introduced in Einstein's theory of general relativity, we know that we do not need to be at the center of the universe to see all the galaxies moving away from us. If space itself is expanding (a natural occurrence within the framework of general relativity), then the galaxies will be carried along for the ride, and no matter where you are in space, you will see other galaxies moving away from you. An oft-used analogy is of coins on an expanding balloon. Viewed from any point on the surface of the balloon, all the other coins appear to recede as the balloon expands. Points farther away from the given point recede at a greater rate than closer points (fig. 21.9). Within the context of this "expanding space" explanation of the observations, the cosmological red shift is now thought of as a relativistic effect of the expansion of space itself. (Imagine a light wave drawn on a balloon. As the balloon expands, the wavelength of the light increases as it is stretched, turning green light, say, into red.)

### Tracing back toward the beginning of our universe

If space is expanding, at some point in time long ago the entire mass of the observable universe must have been much more compressed than it is now. (Imagine making a video of the expanding universe, and now imagine running that video in reverse.) Thus, the idea of expanding space, introduced in order to explain the Hubble law, suggests that at some point

in the past (about 13.7 billion years ago, according to the best current estimates) our universe existed in a very dense, hot state, from which it has been expanding ever since. This framework is known as the **Big Bang** theory as a way of describing the expansion from a hot, dense beginning. But the term is also a bit misleading. It implies an explosion of material *into* space, when the reality is an *expansion of space* itself. (In fig. 21.9, notice that the coins spread apart due to space expanding, rather than moving along the balloon and away from one particular region of the balloon's surface, as would be the case in an explosion.)

We can apply our knowledge of physics to predict what conditions must have been like in the universe at different times as we run the video backward. At some point, the galaxies would have been touching. At a still earlier time, so much matter and energy was compressed into such a small space that matter no longer consisted of individual atoms and molecules. The electrons get stripped from the atoms, and what is left is a dense plasma of electrons, protons, and neutrons. At even higher densities, the protons and electrons combine to form neutrons.

A similar process probably still occurs in small regions of the cosmos today, in the gravitational collapse of stars that have used up their fusion fuel, resulting in very small and dense *neutron stars*. If such a star has sufficient mass, it might collapse still further to form a *black hole* (see section 20.5). At even higher densities, the matter would exist as a sea of quarks, in which individual quarks would not belong to specific neutrons or protons. Physicists are able to re-create very tiny versions of this extremely dense state of matter using accelerators (section 21.1).

In the earliest stages of the Big Bang (just a microsecond or so after the beginning), all the matter we see today existed as an extremely hot sea of quarks. As the expansion proceeded, the matter behaved like a gas, cooling off and condensing. The quarks condensed into mesons and baryons, including neutrons and protons. A few minutes after the beginning, the protons and neutrons probably began to fuse into nuclei, primarily isotopes of hydrogen and helium.

At a much later point (about 400,000 years after the beginning), the universe had cooled down enough for electrons to remain bound in orbits about the nuclei to form neutral atoms of hydrogen and helium. Gravitational attraction produced clumps of matter that became galaxies, and matter within these galaxies condensed into individual stars. The synthesis of larger nuclei by fusion reactions began to take place within the stars.

The standard model of high-energy physics, discussed in section 21.1, has been able to predict how some of these steps could have occurred. The model has had success in explaining certain astronomical observations, including the ratio of helium to hydrogen observed in stars and galaxies. Another confirming observation has been the detection of the uniform background of microwave radiation, predicted as a residual effect of the Big Bang itself. Many physicists consider the existence and general uniformity of the

background radiation to be some of the strongest evidence confirming the Big Bang scenario.

Our success in describing the world of the very small (nuclei and quarks) plays a large role in our understanding of the universe. Much of this success has been achieved in only the last 40 years or so, but more remains to be done. Advances in the theory of fundamental forces are quickly applied to models of the universe to test their implications. In turn, advances in our understanding of the very large suggest new discoveries in particle physics. For example, cosmologists now have strong evidence that most of the matter in the universe is not the “normal” matter of which our everyday world is composed. Rather, it must be some form of “exotic” dark matter (interacting via gravity but not interacting with light, and not made out of quarks as our familiar protons and neutrons are). Particle physicists at CERN and other laboratories are conducting experiments, hoping to confirm the existence of these exotic dark matter particles.

There are still many unanswered questions. Because we still have not achieved a completely unified field theory, we cannot model the very earliest stages of the Big Bang. Therefore, we cannot describe with assurance the initial conditions of the universe. There may be many universes, some of which have evolved differently than our own. The ultimate fate of our universe is also still an open question. Recent evidence suggests that the rate of expansion is increasing with time, and our universe will continue expanding forever. But perhaps some as yet unknown effect will eventually slow the expansion. These questions about the origin, destiny, and nature of the universe hold a tremendous fascination for physicists, astronomers, philosophers, and the general public.\*

Our own solar system is a small part of the Milky Way galaxy, which is just one of many observable galaxies. The discovery that distant galaxies are receding from us led to the Big Bang theory of the expanding universe. Models of the early phases of this expansion are based on our knowledge of the elementary particles and forces discussed in section 21.1. These models have succeeded in explaining and predicting many astronomical observations.

## 21.3 Semiconductors and Microelectronics

The cell phones, watches, microwave ovens, desktop and laptop computers, automobiles, and countless other devices we use every day employ computer technology. All of these devices use transistors and other forms of solid-state electronics. All of these advances follow from the invention of the transistor in 1947.

\*For further reading on these questions, and cosmology in general, see Duncan and Tyler, *Your Cosmic Context: An Introduction to Modern Cosmology*, San Francisco: Addison-Wesley, 2009.

What are *solid-state electronics*? What led to the current revolution in technology? Although these electronic devices are part of our everyday experience, how they work is invisible to us. Despite their enormous importance to our economy, most people have little understanding of how they function.

### What are semiconductors?

In chapter 12, we discussed the distinction between electrical conductors and insulators. Good electrical conductors, mostly metals, permit a relatively free flow of electrons or other charge carriers through the material. Good insulators do not. There is an enormous difference in the values of electrical **conductivity** between these two types of materials. Conductivity is a property of the material that together with its length and width, determines its electric resistance—a high conductivity yields a low resistance.

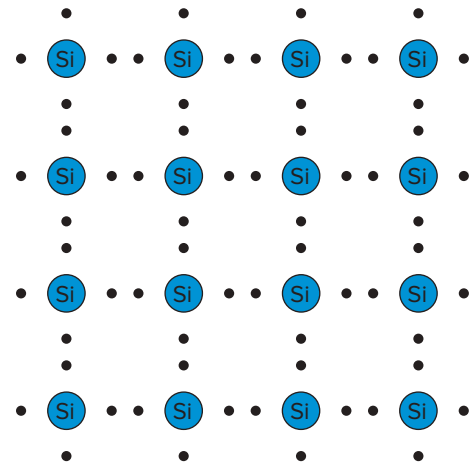
Table 12.1 listed some conductors and insulators, as well as a few members of a third category called *semiconductors*. Semiconductors have a much higher conductivity than good insulators but a considerably lower conductivity than good conductors. What causes these differences in electrical conductivity? Can we predict which materials will be good conductors, insulators, or semiconductors?

If you examine the periodic table, you will see that the metals all lie on the left side of the table or in the transition regions. These elements have just one, two, or sometimes three electrons outside of a closed shell of electron states (see chapter 18). These outer electrons are responsible for the chemical properties of a particular element. Less tightly bound to the nucleus of the atom than the other electrons, they are relatively free to migrate within the material as conduction electrons.

On the other hand, elements that make good insulators lie on the right side of the periodic table. These elements are lacking one, two, or three electrons needed to complete a shell. They readily accept electrons from other elements when they combine to form chemical compounds. When they bond together in their pure state to form solids or liquids, there are no loosely bound electrons to contribute to electrical conduction.

The elements commonly listed as semiconductors (germanium and silicon) are found in column IVA of the periodic table. These elements have four outer electrons beyond a closed shell. When these elements bond together in a solid, electrons are shared with neighboring atoms, as in the two-dimensional depiction in figure 21.10. (The actual crystal structure is three-dimensional, of course, which is harder to show.) These shared electrons are more closely tied to their corresponding nuclei than in a metal, but they are freer to migrate through the substance than in a good insulator. The conducting properties of these materials are thus intermediate between metals and good insulators.

Although germanium and silicon are semiconductors, they do not conduct well in their pure form. Semiconductors' importance in electronics results from our ability to modify their



**Figure 21.10** A two-dimensional representation of the sharing of the four outer electrons of silicon with neighboring atoms in solid silicon.

conductivity by **doping** them with small amounts of impurity.

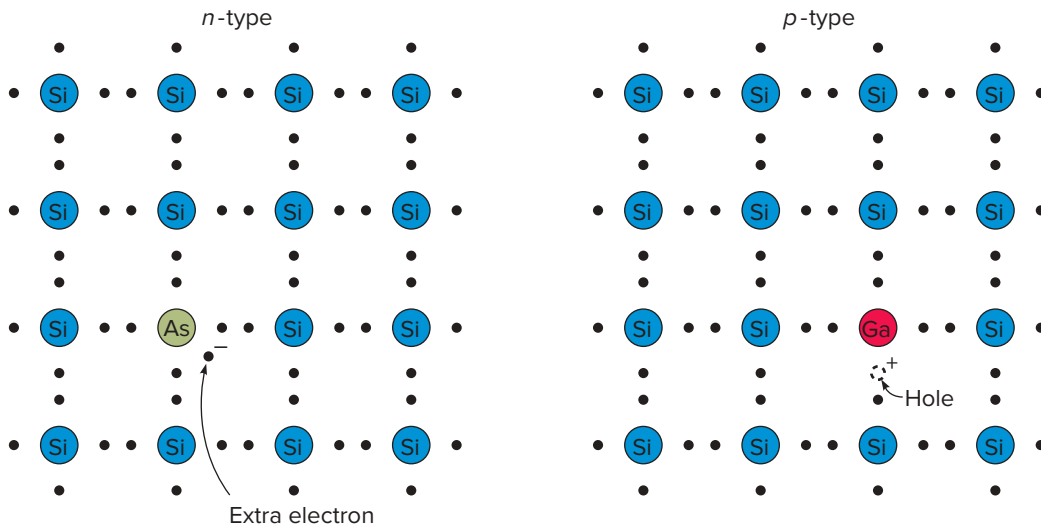
Suppose, for example, that we add a small amount of phosphorus or arsenic to silicon. These elements lie in column VA of the periodic table and have five outer electrons (fig. 21.11). Four of these five electrons will participate in the bonding of the impurity with neighboring silicon atoms. The fifth electron, however, is not needed in these bonds and will be free to migrate through the material. The doping therefore introduces conduction electrons into the material, making it a better conductor than pure silicon.

Doping with phosphorus, arsenic, or antimony produces an *n*-type semiconductor, because the charge carriers are negatively charged electrons. We can also produce *p*-type doping, for which the charge carriers are positive, by adding impurity atoms of elements from column IIIA in the periodic table, most commonly boron, gallium, or indium. Because atoms of these elements have just three outer electrons, they leave a *hole* in one of the bonds between the impurity atom and the neighboring silicon atoms (fig. 21.11).

A hole is the absence of an electron—but these holes can also migrate through the material. A moving hole behaves as a positive charge carrier, because it leaves an excess positive charge (associated with the charge on the nucleus of the silicon atoms) wherever it goes. Electrons from neighboring silicon atoms move in to fill the hole, leaving an excess positive charge somewhere else in the material.

### What is a transistor?

Besides improving the conducting properties of semiconductors, doping plays a crucial role in producing semiconductor devices. The boundaries between *p*- and *n*-type materials have properties that are very useful in electronics. These boundaries, called *junctions*, are essential to the operation of diodes, transistors, and related devices.



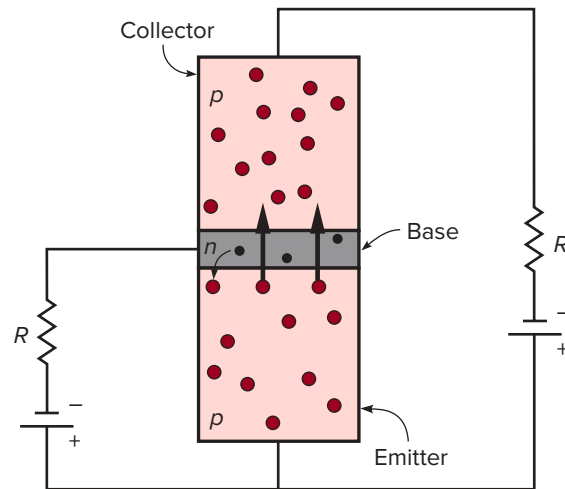
**Figure 21.11** Doping silicon with phosphorus or arsenic provides an extra electron, making an *n*-type semiconductor. Doping with boron or gallium leaves holes and produces *p*-type material.

A **diode** is a device that allows electric current to flow in one direction but not in the opposite direction. It consists of a *p*-type semiconductor bonded to an *n*-type semiconductor, forming a junction between them. If a battery is applied to this device with the positive terminal connected to the *p*-type material and the negative terminal to the *n*-type, the positive holes in the material will be driven toward the junction with the *n*-type material where they can combine with electrons. A large current will then flow. If the battery is connected in the opposite direction, no current flows. Diodes are useful in a large variety of electric circuits.

The most revolutionary development involving semiconductors, however, was the invention of the **transistor**. In its simplest form, a junction transistor consists of a very thin piece of semiconductor with one type of doping sandwiched between two pieces with the opposite doping, as shown in figure 21.12. This drawing shows what is called a *p-n-p* transistor, and the thickness of the materials has been grossly exaggerated to show the electrons and holes. There are two junctions in such a transistor. We can also make *n-p-n* transistors with the opposite dopings for the different parts of the sandwich.

The operation and properties of the transistor are pictured in a simple circuit in figure 21.12. The operation depends on the voltage applied to the center piece of the sandwich, called the *base*. If no electrons are introduced to the base by the battery, the holes in the *emitter* (the bottom *p*-type piece) cannot flow across the two junctions and into the *collector* (the top *p*-type piece). If the negative voltage applied to the base is increased, however, holes in the emitter are attracted to the base and a current can flow between the emitter and the collector. Small changes in the base current and voltage can thus have a large impact on the current flowing between the emitter and collector.

This simple description leaves out a lot of important details, but it contains the basic reason transistors are so useful.



**Figure 21.12** The rate of flow of holes from the emitter to the collector of a *p-n-p* transistor depends on how much current is allowed to flow to the *n*-type base of the transistor.

Small variations in the electrical signal applied to the base can produce large variations in the current flowing through the device. This makes a transistor very handy for amplifying electrical signals. A weak signal picked up by a radio antenna, for example, can be turned into a larger signal to drive the speakers of a radio. Prior to the invention of the transistor, amplification was done with vacuum tubes, which are much larger than transistors and generate more heat. Transistor radios were among the earliest products utilizing transistors for amplification. They were small enough to be easily carried around and became very popular in the 1950s. Transistors are now used for amplification in all kinds of devices, including radios, TVs, and stereo amplifiers.

The transistor was invented in 1947–1948 by scientists at Bell Laboratories in New Jersey. These included William

Shockley, who invented the junction transistor in 1948, and John Bardeen and Walter H. Brattain, who first demonstrated transistor action in a simpler but less effective “point-contact” transistor in 1947. These inventions resulted from the growth in our understanding of the physics of semiconductors over the previous 50 years. By 1960, transistors were being used routinely in many electronic applications.

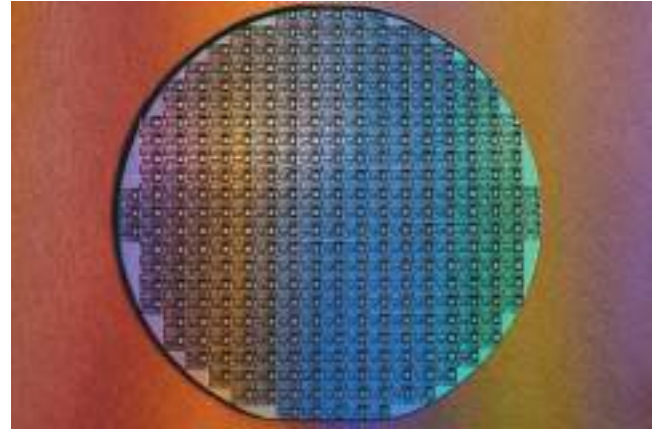
### Computers and integrated circuits

An even more important application of the transistor than its role in amplification is its use as a voltage-controlled switch. One voltage applied to the base allows current to flow (the switch is on), and a smaller or zero voltage allows no current to flow (the switch is off). This may seem mundane, but it lies at the heart of the operation of all digital computers. A computer uses binary logic in which information is stored and processed in zeros (0) and ones (1), or off or on. This is essentially the function of a switch. The earliest computers used either mechanical switches (called relays) or vacuum tubes for this purpose. This made these computers enormous, even though they had very weak computing power by today’s standards. They also required lots of electric power and generated lots of heat.

Transistors changed all of that. During the 1950s, transistors quickly replaced vacuum tubes and relays in the development of ever more powerful computers. Computers became important for doing complex computations and ultimately changed the way things were done in many branches of science. They also began to be heavily used in business and accounting applications. (One of the major companies in the early development and sales of computers was International Business Machines, or IBM.) The computers developed in the 1950s and 1960s were still much larger than those in use now, however.

The next important step in making computers both smaller and more powerful was the invention and development of integrated circuits during the 1960s. An **integrated circuit** consists of many transistors, diodes, resistors, and electrical connections, all built into a single, tiny *chip* of semiconductor material, usually silicon. This advance allowed the production of circuits that were much smaller than those made from individual transistors and other components mounted on a circuit board. A computer that might fill a small room using individual transistors could then be reduced to the size of a handheld calculator.

The production process for integrated circuits begins with the growth of a large, cylindrical crystal of doped silicon. This crystal is sliced into *wafers*, which are generally several centimeters in diameter but just a few millimeters thick (fig. 21.13). The wafers are polished and then pass through a long series of steps in which insulating oxides are layered on the wafer, and circuit patterns are overlaid by photographic methods. Some regions are masked, and the unmasked portions are doped opposite to the underlying silicon to produce diodes and transistors. Metal strips are overlaid to provide

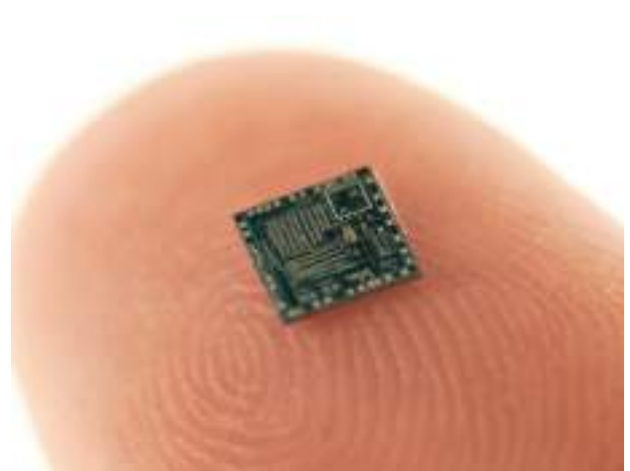


**Figure 21.13** The starting point in producing integrated circuits is a polished wafer of single-crystal silicon. The wafer shown here has been processed to produce tiny circuits on its surface.  
*Fuse/Getty Images*

conducting connections between circuit elements. All of this must be done within *clean rooms*, in which great care is taken to avoid contamination by dust and other foreign substances.

Several identical circuits are usually imprinted on a single silicon wafer. Near the end of the process, the wafer is cut into individual chips, each containing a miniature circuit. An individual wafer may yield a hundred or more chips like the one pictured in figure 21.14. The final steps involve making electrical connections to the chip, packaging the chip in a sealed plastic enclosure (fig. 21.15), and testing the resulting circuits. Producing integrated circuits (ICs) is a major industry.

Competition to produce ever smaller and faster circuitry for computers and related applications continues to push the technology forward. There are two advantages to making



**Figure 21.14** A single integrated circuit chip resting on a fingertip. Millions of circuit elements may be contained on such a chip, and many chips can be produced from a single silicon wafer.  
*Lucidio Studio Inc./Photographer's Choice/Getty Images*





**Figure 21.15** Rows of packaged microchips arranged on the circuit board of a computer.

Nata-Lia/Shutterstock

the circuit elements on a computer chip both smaller and closer together. One is the obvious advantage of fitting more elements on a chip, making ever smaller and lighter devices. The other advantage is less obvious but just as important. As the distance between individual elements such as transistors decreases, the speed of the resulting devices increases. This results from the fact that electrical signals from one element to another have less distance to travel. Although these signals travel extremely fast (approaching the velocity of light), an incredible number of individual steps take place in the operation of a computer chip, and they take time. The heat generated in such a tiny area must be dissipated, which is an additional challenge that engineers have had to address.

Technology is now in the nanometer realm, which implies that the distance between circuit elements on a chip is being reduced to just a few nanometers. Some of the chips contain as many as a billion transistors. This is a mind-boggling number. It means that a single computer chip smaller than a square centimeter contains much larger computing power than the relatively huge computers of the 1950s and 1960s. Miniature computers are incorporated, at low cost and low power consumption, into all kinds of devices.

These advances in semiconductor electronics have produced an explosion of new products, including ever more versatile cell phones, digital cameras, global positioning devices, and so on. The so-called technology sector is a huge part of our national economy. Both physics and chemistry play large roles in the research and development efforts that drive improvements in the processing techniques involved in making computer chips and related devices. For some applications, silicon is being replaced by other semiconductor materials, such as germanium or gallium arsenide. The physics of semiconductor materials has become one of the largest areas of research in modern

physics. The revolution in semiconductor electronics is still proceeding.

Semiconductors are materials with conducting properties intermediate between good conductors, like metals, and good insulators. We can affect their conductivity by doping them with impurity elements that donate extra electrons or leave electron gaps (holes) in the bonds between atoms. This permits the construction of diodes and transistors that are much smaller than earlier circuit elements. Transistors can produce large changes in current or voltage from small *changes*, which permits them to be used for amplifying electrical signals. Transistors can also be used as switches, which is a crucial function in the operation of computers. The development of integrated circuits that contain an enormous number of transistors and other circuit elements on a single chip produced an explosion in computer technology.

## 21.4 Superconductors and Other New Materials

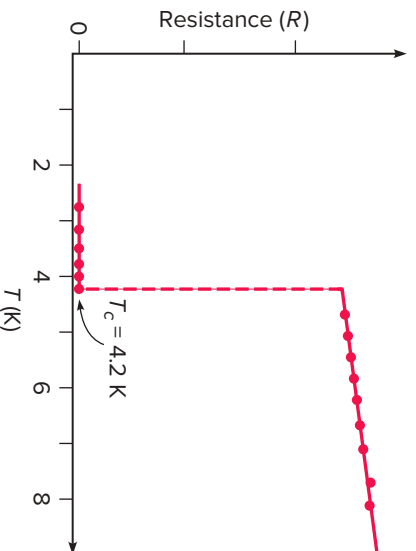
A major scientific news item during the late 1980s was the discovery of so-called high-temperature superconductors. A series of news stories claimed that Japan was ahead in the superconductor race and speculated about exotic applications of superconductors. The news flap was almost as great as the one surrounding the supposed discovery of cold fusion a year or so later.

What was all the excitement about? What is superconductivity? What does temperature have to do with it, and what other exotic materials are in the works? These questions stem from a field called *materials science*, a combination of metallurgy, chemistry, and condensed-matter physics. Materials research is another physics-related discipline that has already had a major impact on technology and the way we live.

### What is superconductivity?

**Superconductivity** is a phenomenon in which the resistance to the flow of an electric current completely disappears. It was originally discovered in 1911 by a Dutch physicist, Heike Kamerlingh Onnes. Onnes found that if he cooled mercury to a temperature of about 4 K (4 degrees above absolute zero), the electric resistance of his sample completely disappeared. An electric current, once started, would flow indefinitely with no continuing source of power.

The electric resistance of most materials decreases with decreasing temperature, but in Onnes's mercury sample, the resistance completely disappeared at the temperature of 4.2 K, as illustrated in figure 21.16. The resistance drops



**Figure 21.16** The electric resistance of mercury decreases as the temperature is decreased. It drops abruptly to zero, however, at the critical temperature of 4.2 K.

abruptly to zero at the **critical temperature**  $T_c$  and is zero for any temperature below the critical temperature.

Further research showed that many metals become superconducting if cooled to a low-enough temperature. The metal niobium has one of the highest critical temperatures of a pure substance at 9.2 K. Some alloys have even higher critical temperatures. In 1973, an alloy of niobium and the semiconductor germanium was discovered to have a critical temperature of 23 K, still a very low temperature: 23 K is equal to  $-250^\circ\text{C}$  ( $-418^\circ\text{F}$ ).

A theoretical explanation for the phenomenon of superconductivity, developed in 1957, applies quantum mechanics to the behavior of electrons in a low-temperature metal. This explanation is closely related to a theory that explains the behavior of **superfluids**, a phenomenon also observed at very low temperatures. Liquid helium becomes a superfluid below a critical temperature where it loses its viscosity (or resistance to the flow of the fluid), just as a superconductor loses its electric resistance. Both superconductivity and superfluidity are macroscopic quantum phenomena: Quantum mechanics explains their characteristics, but they are observable on the size scale of ordinary objects rather than at microscopic sizes.

### What are high-temperature superconductors?

In 1986, a new type of superconducting compound—a ceramic material composed of a metal oxide containing various other elements—was discovered. The original ceramic superconductor had a critical temperature of 28 K, not much higher than those of the metal alloys. The discovery provoked a flurry of experimental activity, however, in which other combinations of elements were tried. By 1987, ceramic superconductors had been developed with critical temperatures first of 57 K and then of 90 K. Finally, in 1988, there were reports of materials with critical temperatures of over 100 K, and perhaps as high as 125 K.

These new ceramic superconductors are *high-temperature superconductors*. Though termed “high-temperature,” these critical temperatures are still not what we would normally consider high—for instance, 100 K is  $-173^\circ\text{C}$ , which is still rather cold by most standards. The development of materials with critical temperatures around 90 K was a breakthrough, though, because these temperatures can be reached using liquid nitrogen. Liquid nitrogen is readily available for industrial and scientific uses. It boils at 77 K ( $-196^\circ\text{C}$ ), so a bath of liquid nitrogen can cool samples to that temperature.

Ceramic superconductors are made of various combinations of materials, and most have copper oxides as one of the components. The most commonly available superconducting ceramic material is a combination of yttrium (Y), barium (Ba), copper (Cu), and oxygen (O) in the proportions  $\text{Y}_1\text{Ba}_2\text{Cu}_3\text{O}_7$ . (The number of oxygen atoms in the structure varies, depending on how the material is prepared.) This material can be prepared in undergraduate laboratories and has a critical temperature of approximately 90 K.

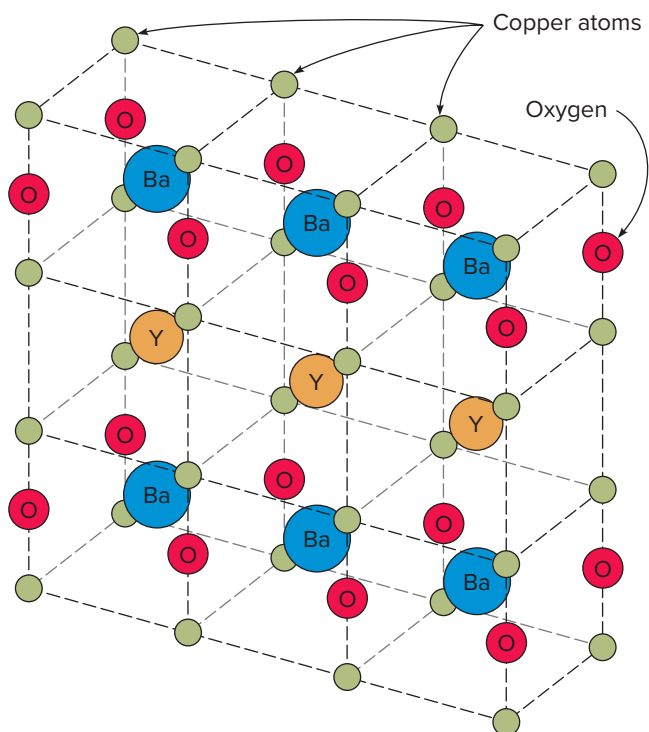
One striking property of a superconductor (called the *Meissner effect*) is that it will completely exclude magnetic field lines produced by an external magnet or electric current. A magnet brought near a superconducting material will be repelled. This property is commonly demonstrated by levitating a small magnet above a disk of superconducting material. (The materials for this demonstration have been widely distributed to science teachers.) A small amount of liquid nitrogen at the bottom of a Styrofoam cup is sufficient to cool the superconducting disk (fig. 21.17).

The theory that successfully explained superconductivity in pure materials was not adequate for explaining the superconductivity of these new ceramic materials. A common feature of the structure of many of these materials is that they contain layers of copper or copper oxide sandwiched between the atoms of the other elements



**Figure 21.17** A small magnet levitates above a superconducting disk cooled with liquid nitrogen. This simple test establishes the presence of superconductivity.

Lawrence Manning/Digital Stock/Getty Images



**Figure 21.18** The atomic structure of many superconducting ceramics has layers of copper atoms sandwiched between other elements, such as oxygen, yttrium, and barium.

(fig. 21.18). The superconduction is suspected to occur through these layers, and theoreticians have made good progress in understanding what is happening. Continued theoretical and experimental progress could point the way to designing materials with even higher critical temperatures.

High-temperature superconductors have many potential applications, especially in the use of electromagnets. A strong electromagnet requires large currents flowing in tightly wound coils of wire. With ordinary conductors, these large currents generate a great deal of heat and limit the amount of current that can be established (and the resulting strength of the electromagnet). Magnets already exist that use superconducting coils, but they must be maintained at temperatures below the critical temperature of the superconducting material. If we had materials that were superconducting near room temperature, such electromagnets would become much more feasible for general use.

A superconducting supercollider (SSC) project, which was canceled, would have used superconducting magnets to control particle beams used for observing reactions between elementary particles. Such magnets are now being used in other accelerators. Superconducting magnets are also used in magnetic resonance imaging (MRI) devices, an important diagnostic tool in medicine (fig. 21.19). Other possible applications include the magnetic levitation of trains and other vehicles to reduce friction and attain higher speeds. Superconducting cables could be used in power transmission to



**Figure 21.19** A patient is about to enter the chamber housing the superconducting magnets of a magnetic resonance imaging (MRI) instrument.

*ERproductions Ltd/Blend Images*

reduce losses from electric resistance. For most applications, the operating costs would be greatly reduced if we had room-temperature superconducting material that did not require elaborate cooling systems.

Most of these applications need superconducting materials that can be readily shaped into wires and cables, with even higher critical temperatures than those available now. Many of the ceramic superconductors are quite brittle and not suitable for cables or magnetic coils. Success in inventing more usable superconducting materials may await a new generation of scientists, engineers, and dreamers.

### Other exotic materials

The discovery of the new superconductors was sparked by research on ceramic metal oxides already known to have interesting electrical properties. For example, a compound of barium, titanium, and oxygen, called barium titanate ( $\text{BaTiO}_3$ ), had been used for many years to convert changes in pressure into electrical signals, and vice versa. This property allows a crystal of barium titanate to be used as a tiny microphone or speaker. Other metal oxides are important in integrated-circuit processing.

The search for new materials stems from our growing knowledge of how atoms interact in the solid or liquid states. We have become more able to design materials to meet specific needs. These needs may be special optical or electronic properties for use in electronics and communications, or perhaps high-strength but lightweight materials for aircraft. Different elements can be combined in an infinite number of ways to make new materials, and the results cannot always be predicted.

Liquid crystals are one of the new materials that have found extensive application. Liquid crystals have a crystal-like organization in one direction but are disordered and free to flow in other directions in the material. They have some



**Figure 21.20** The long molecules in some liquid crystals line up in layers, allowing the liquid to flow along these layers but not in the perpendicular direction.

properties of both liquids and solids. Electric fields can affect how much light flows through the material. This property has led to their use in display screens of handheld calculators and in very thin, flat television screens that do not require a bulky cathode-ray tube.

Liquid crystals are often made up of long, organic (carbon-based) molecules that line up in layers, as in figure 21.20. These layers slide along one another, so that the material can flow in the directions parallel to the layers. The regular spacing perpendicular to these layers causes the crystal-like properties. One of this book's authors (WTG) has conducted research on another class of substances known as *plastic crystals*, whose molecules are globular in shape and partially free to rotate in the solid crystal. Plastic crystals have many interesting properties, but so far they have not led to the extensive applications that have grown out of research on liquid crystals.

It is hard to know just where this research will lead. We can be sure of two things: Some new materials will have unexpected and exciting properties, and some of these materials will lead to new products you will encounter in your everyday activities.

Everyday phenomenon box 21.1 discusses another modern development resulting from research in physics, this one in the subfield of optics. We are now exploring the use of holograms for data storage in computers, which requires the development of special optical materials.

Superconductors are materials that lose all resistance to the flow of an electric current below a critical temperature. For pure metals, these critical temperatures are only a few degrees above absolute zero, but more recently, superconducting compounds have been discovered with critical temperatures of 100 K or above. These high-temperature superconductors may someday find extensive applications in power transmission or in superconducting magnets. Materials science has invented many other exotic materials, including the liquid crystals used in display panels for calculators and laptop computers. Our increasing knowledge of how atoms interact in the solid and liquid states lets us design materials for specific applications, but their precise properties still hold surprises.

## Everyday Phenomenon

## Box 21.1

### Holograms

**The Situation.** We all have seen holograms on cereal boxes, toys, credit cards, and perhaps simple jewelry, such as the pendants shown in the photos. Although the credit cards and other surfaces are clearly two-dimensional, the images we see in a hologram are three-dimensional. We can move our head from side to side and view these images from different perspectives, just as we can with a real three-dimensional object. How are these three-dimensional images produced?

Holography seems like science fiction to many people. What can actually be achieved with holograms? What are they, and how do we go about making them? Could holograms be used to develop three-dimensional television or movies?

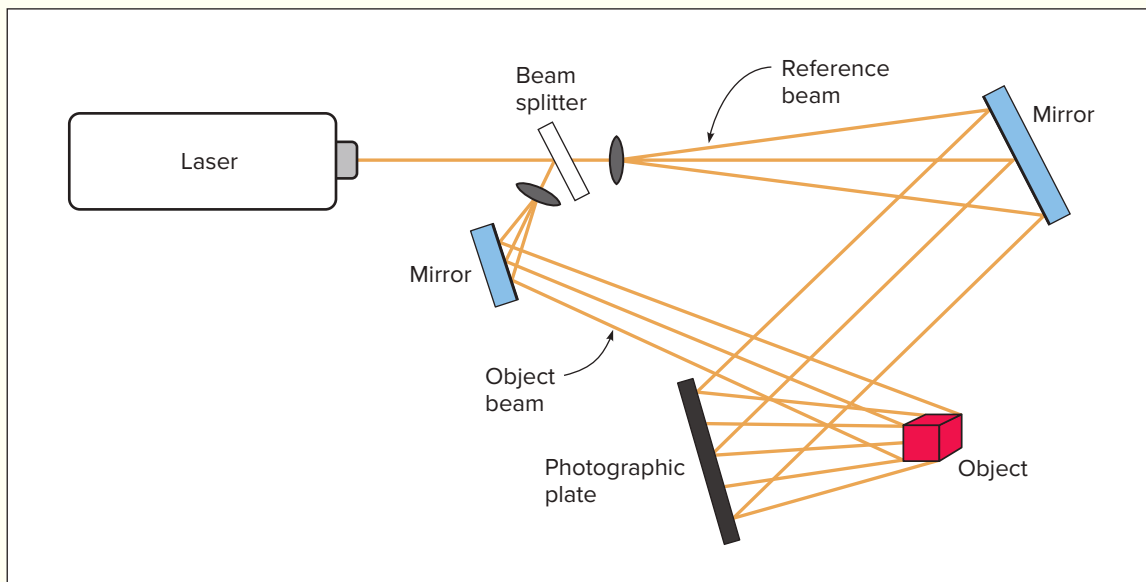
**The Analysis.** Although the idea was conceived earlier, the first good holograms were produced in the early 1960s following the invention of the laser. A **hologram** is an interference pattern produced by combining light waves reflected from an object with another wave coming directly from the laser. Lasers are highly



A hologram on a pendant viewed from two different angles. How is this three-dimensional image produced?

both: Bob Coyle/McGraw-Hill Education

(continued)



Light from a laser is split into two beams, one of which is reflected from an object and interferes with a second (reference) beam to form a hologram.

*coherent* light sources—they produce much longer wave trains than ordinary light sources, which produce short, uncorrelated pulses of light. The high coherence of the laser is needed to produce interference patterns of light scattered from objects of ordinary size.

A common arrangement for making a hologram is shown in the drawing. Light coming from the laser is split by a partially silvered mirror or beam splitter into two beams, one called the *object* beam and the other the *reference* beam. The object beam is scattered or reflected by the object back toward the photographic plate. The reference beam is directed to the photographic plate at an angle to the object beam, and these two beams of light then combine to produce an interference pattern on the photographic plate.

When the photographic plate is developed, the recording of the interference pattern becomes the hologram. If light similar to the original laser light passes through the hologram, the interference pattern modifies the light, so that one of the light waves transmitted is identical to the original light wave reflected from the object. This identical light wave is what we view when we look at a hologram. This light wave is diverging from an image of the original object—we are observing a three-dimensional virtual image. (See chapter 17 for a discussion of image formation.)

The most familiar holograms are reflection holograms, designed to be viewed in light reflected from the hologram

rather than light transmitted through the hologram. Reflection holograms have the additional advantage that we do not need a laser or other monochromatic light source to view them. The reflection process selects out only certain wavelengths of light. In the reflection holograms on cereal boxes and credit cards, the interference pattern representing the hologram is embossed onto a thin reflecting film. Holograms are used on credit cards because it is extremely difficult to produce counterfeit copies.

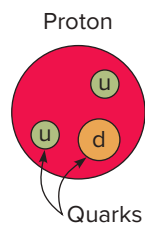
Originally, the process of making holograms required that the object be held completely still, with no vibrations, to produce an accurate interference pattern. More powerful lasers and better films now allow shorter exposure times, so objects do not have to be kept quite as motionless. It is also possible to generate the interference patterns from mathematical computations on a computer, so that we can design computer-generated holograms of nonexistent objects. A single hologram contains an enormous amount of information, however, so moving holograms that can be transmitted by television signals are not yet feasible.

The invention of the laser in 1960 spurred tremendous growth in the field of optics. Holography is just one of the applications that this amazing light source has made possible. Holography is now used in many technical applications, as well as in art, special displays, and novelty items.

## Summary

In this chapter, we have gone beyond everyday phenomena to touch on some of the more exciting discoveries in the continually advancing areas of research in physics. The ideas explored included quarks and other elementary particles, cosmology and the Big Bang, integrated circuits, computers, and superconductors and other “designer” materials.

**1 Quarks and other elementary particles.** The standard model of high-energy physics can now describe all of the known particles as combinations of 24 elementary particles—6 leptons, 6 quarks, and their antiparticles. Progress has been made in bringing the fundamental forces of nature into a single *unified field theory*.

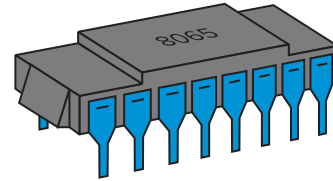


**2 Cosmology: Looking out into the universe.** Astronomical observations have shown that our sun is just one star in a large galaxy of stars and that there are many other galaxies, all receding from one another in an expanding universe. Knowledge of quarks is necessary to model the earliest moments of the universe following the Big Bang, which started the current expansion.



NASA/JPL-Caltech/S. Willner (Harvard-Smithsonian Center for Astrophysics)

**3 Semiconductors and microelectronics.** Our understanding of semiconductors and how their conductivity can be modified by doping with impurity atoms led to the invention of the transistor in the late 1940s. Since then, integrated circuits have been developed by combining hundreds of transistors and other elements on tiny silicon chips. A tremendous industry has grown from this ability to miniaturize electronic and computer circuitry.



**4 Superconductors and other new materials.** Superconductors are materials that lose all of their electric resistance below a certain critical temperature. Ceramic superconductors have been discovered with critical temperatures around 100 K, much higher than those previously known but still well below room temperature. Research in the physics of solids and liquids has produced many other useful materials, such as the liquid crystals used in calculator displays and similar applications.



Lawrence Manning/Digital Stock/Getty Images

## Key Terms

Standard model, 458

Positron, 458

Muon, 458

Pion, 458

Lepton, 458

Meson, 458

Baryon, 460

Quark, 460

Hadron, 460

Strong nuclear interaction, 461

Weak nuclear force, 461

Unified field theory, 461

Electroweak force, 461

Grand unified theories, 461

Cosmology, 461

Galaxy, 462

Luminosity, 463

Big Bang, 464

Conductivity, 465

Doping, 465

Diode, 466

Transistor, 466

Integrated circuit, 467

Superconductivity, 468

Critical temperature, 469

Superfluid, 469

Hologram, 471

## Conceptual Questions

\* = more open-ended questions, requiring lengthier responses, suitable for group discussion

Q = sample responses are available in appendix D

Q = sample responses are available in Connect

- Q1. Are leptons generally heavier than protons or neutrons? Explain.
- Q2. Do we now consider protons to be elementary particles that do not have any underlying structure? Explain.
- Q3. Are quarks constituents of electrons? Explain.
- Q4. Are baryons and mesons made up of the same number of quarks? Explain.
- Q5. Why are high energies required to produce particles with larger masses than protons or neutrons? Explain.
- Q6. Which fundamental force of nature is the most difficult to incorporate into a completely unified field theory? Explain.
- \*Q7. Why do physicists propose spending large amounts of money to build new particle accelerators? How can we justify these large expenditures? Explain.
- \*Q8. How do we know that the universe is expanding? Explain.
- Q9. Is our own sun part of a galaxy? Explain.
- Q10. Is the Milky Way a cloud of interstellar gases? Explain.
- Q11. What force is responsible for the formation of atoms from individual nuclei and electrons? What force is responsible for the condensation of individual atoms into stars? Explain.
- Q12. Are bright stars you see in the sky always closer to us than fainter stars? Explain.
- Q13. Describe two astronomical discoveries that provide strong support for the idea that space is expanding (the Big Bang theory).
- Q14. What are Cepheid variable stars, and why are they important in cosmology?
- Q15. Does the term *Big Bang* refer to explosions of individual stars? Explain.
- Q16. Is it necessary to know anything about very small entities, such as quarks, to produce successful models of very large-scale phenomena, such as the beginning of the universe? Explain.
- Q17. Is the electric resistance of a semiconductor, such as silicon, increased when we dope it with impurity atoms of arsenic? Explain.
- Q18. Does doping of silicon with gallium make the resulting semiconductor an *n*-type or *p*-type semiconductor? Explain.
- Q19. Does the direction in which the battery is connected to a diode affect the amount of electric current that will flow through the diode? Explain.
- Q20. Can a diode be made from material that is doped with just one type of impurity atom? Explain.
- \*Q21. What property of transistors makes them useful for amplifying an electrical signal? Explain.
- Q22. In making ever-smaller electronic instruments, do integrated circuits have an advantage over the use of separate transistors and diodes? Explain.
- Q23. Does a superconductor have zero resistance only *above* a certain critical temperature? Explain.
- Q24. With the high-temperature superconductors currently available, can we build superconducting magnets that will operate in a superconducting mode at room temperature? Explain.
- Q25. Are superfluids the same as superconductors? Explain.
- Q26. Are liquid crystals fluids or solids? Explain.
- Q27. How do the two views of the hologram of the pendant in everyday phenomenon box 21.1 differ? Or are they identical? Explain.
- Q28. Can we make holograms using an ordinary light source rather than a laser? Explain. (See everyday phenomenon box 21.1.)

## Exercises

- E1. The average distance from the sun to Venus is approximately  $1.1 \times 10^8$  km. How many seconds are required for light to travel from the sun to Venus? ( $c = 3 \times 10^8$  m/s, 1 km = 1000 m)
- E2. Suppose that violet light of wavelength 380 nm was shining from a star in a distant galaxy at some point in the past. In

the time the light took to reach Earth, the universe expanded by a factor of 1.6 (all distances have been multiplied by 1.6). What are the wavelength and color of the light we receive on Earth today? (See section 16.2 to review the colors and wavelengths of light.)

## Synthesis Problems

- SP1. The star nearest our sun is a red dwarf named Proxima Centauri. It is about 4.25 light-years away. (A light-year is the distance light travels in one year.)
- How many seconds are in a year?
  - Given that light travels at the rate of  $3 \times 10^8$  m/s, how many meters are in 1 light-year?
  - How far is it to the nearest star in meters?
  - How long would it take to get to the nearest star if we could travel there at one-tenth the speed of light?

---

## Home Experiments and Observations

---

- HE1. On a clear night (preferably away from city lights), go outside and study the sky.
- Can you see the Milky Way? (It usually appears as a faint cloud of stars, looking like a smoke trail, that makes an irregular band across the sky.) Make a sketch of its orientation.
  - What are the brightest objects in the sky (other than the moon)? Are some of these objects planets? Some planets produce a steadier light than stars (which twinkle) and are quite bright.
  - Can you pick out the Big Dipper (part of the constellation Ursa Major) and other constellations? Make a sketch of the more prominent groupings of stars you observe.
- HE2. Find a hologram on a credit card or obtain a hologram from your instructor and examine it closely.
- As you move your head from side to side, can you see different features of the object? Is the image you see clearly three-dimensional?
  - Move your head up and down as you observe the hologram. Do the colors change? What sequence of colors do you observe? Is there any three-dimensional character to the hologram in the vertical (up-and-down) direction?
- HE3. Create your own scale model of the solar system to help you understand cosmic distances. Pick an object (such as a grapefruit or basketball) to represent the sun. Look up the diameters of the Earth and the sun, as well as the distance from the Earth to the sun. How big should your scale-model Earth be, and how far away should it be from your model sun, to fit the scale? How far away would Proxima Centauri be from your model sun? How about the Andromeda Galaxy?
- HE4. Glue some pennies (or foil stars or any kind of small stickers) onto a balloon that is just barely inflated. The pennies or stickers represent galaxies and should be distinguishable. Then, blow up the balloon with increasing numbers of puffs of air. Measure the distance between three or more distinguishable “galaxies” at each stage—after three puffs, six puffs, nine puffs, and so on—as in figure 21.9. Can you verify that points farther away from a given point recede at a greater rate than closer points? (*Hint:* The time interval between puffs is the same for all galaxies, so you can compare rates of recession simply by comparing the changes in distance between galaxies.)





# Appendix A

## Using Simple Algebra

In chapter 1, we described mathematics as part of the language of physics. It is a compact way of expressing relationships between physical quantities that makes manipulations of these relationships much easier than if they were expressed in words and sentences. People who are conversant in mathematics are very comfortable in interpreting and using such relationships.

Many people are not comfortable using simple mathematics, and therefore mathematics is used sparingly in this textbook. Most of what is used is basic algebra, to which most college students have been introduced in high school. Often, that introduction fails to produce a firm understanding of the principles underlying algebraic operations, however, leaving students with little confidence in their use. This appendix presents the basic concepts underlying simple algebraic manipulations and provides illustrations of their application.

### Basic Concepts

Three simple but fundamental concepts form the basis for most algebraic manipulations, which follow.

■ **Concept 1: The letters used in algebra represent numbers. Any operation performed with numbers (addition, subtraction, multiplication, division, and so on) can also be performed with these symbols.**

In mathematics courses, the letters  $x$  and  $y$  are often used to represent unknown numbers, and other letters are used to represent constants or known numbers. In physics, specific letters are used to represent specific quantities:  $t$  for time,  $m$  for mass,  $d$  for distance,  $s$  for speed, and so on. They all represent numerical quantities, but some may be known and others may be initially unknown. The relationship  $s = d/t$ , for example, tells us that we can find the numerical value of speed by dividing a numerical value for distance by a numerical value of time. This relationship holds for any possible values of the distance and time.

■ **Concept 2: If the same operation is performed on both sides of an equation, the equality expressed by that equation does not change.**

This principle is the basis for all algebraic manipulations performed to express a relationship in different forms. For example, if we multiply both sides of the equation  $s = d/t$  by the quantity  $t$ , the equality still holds. This operation yields

$$st = d \frac{t}{t} = d$$

because  $t/t$  equals 1. Performing this operation expresses the original equation in a new form:  $d = st$  tells us that the distance is equal to the speed multiplied by time. We can multiply both sides of an equation by the same quantity, divide both sides by the same quantity, and add or subtract the same quantity from both sides, and the equation is still valid. We can also square both sides of the equation or perform various other operations, but the operations just listed are those most commonly used.

■ **Concept 3: When we solve an algebraic equation, we are merely rearranging the equation as just described, so that the quantity we wish to know is expressed, by itself, on one side of the equation and everything else is on the other side of the equation.**

In the paragraph illustrating concept 2, we solved the equation  $s = d/t$  for the quantity  $d$ , thus expressing the distance in terms of the other two quantities: speed and time. If we wanted to express the time of travel in terms of the speed and the distance, we could divide both sides of the equation  $d = st$  by the quantity  $s$ :

$$\frac{d}{s} = \frac{st}{s} = t \left( \frac{s}{s} \right) = t$$

or  $t = d/s$ , the distance divided by the speed. We see that the original equation  $s = d/t$  can be expressed in two other forms,  $d = st$  and  $t = d/s$ , which restate the original equality in forms suitable for computing a specific quantity when the other two quantities are known—something that is extremely useful.

Because the letters represent numbers (concept 1), we can always check the validity of the operations we perform by inventing numbers for the quantities and checking to see that the equalities still hold in the new form. For example, if in the original equation,  $d = 6$  cm and  $t = 2$  s, then

$$s = \frac{d}{t} = \frac{6 \text{ cm}}{2 \text{ s}} = 3 \text{ cm/s}$$

If we put the same numbers in the final equation,  $t = d/s$ , we have

$$t = \frac{d}{s} = \frac{6 \text{ cm}}{3 \text{ cm/s}} = 2 \text{ s}$$

or  $2 \text{ s} = 2 \text{ s}$ , which is obviously an equality.

These concepts are straightforward, and their application is not difficult once the basic ideas are grasped. A little practice, obtained by following the additional examples given next, and performing the exercises at the end of this appendix, should help build your confidence in using them. For most people who have trouble with mathematics, lack of confidence is the fundamental problem. Often, they have never fully accepted the idea that letters can represent numbers, and so the manipulations and rules of algebra seem arbitrary and mysterious.

## Other Examples

1. Solve the equation  $a = b + c$  for the quantity  $c$ .

*Solution:* We seek an expression in which  $c$  is by itself on one side of the equation, and the other two quantities are on the other side. This can be accomplished by subtracting the quantity  $b$  from both sides of the equation, because doing so will leave  $c$  by itself on the right side:

$$a - b = b + c - b = c$$

Thus, we see that  $c = a - b$ . (It does not matter which side of an equality is stated first—the equality is the same in either case.) By subtracting  $b$  from the right side of the original equation,  $c$  now stands by itself, so we have achieved the desired result.

2. Solve the equation  $v = v_0 + at$  for the quantity  $t$ .

*Solution:* This is best done in two steps. The first step is to subtract the quantity  $v_0$  from both sides of the equation to isolate the product  $at$ :

$$\begin{aligned} v - v_0 &= v_0 + at - v_0 = at \\ at &= v - v_0 \end{aligned}$$

Then, we divide both sides of this equation by  $a$  to get  $t$  by itself:

$$\begin{aligned} \frac{at}{a} &= \frac{v - v_0}{a} \\ t &= \frac{v - v_0}{a} \end{aligned}$$

If you can understand why each of these operations was performed (What was the motivation or objective?), you are well on your way to following the algebra used in this textbook.

3. Solve the equation  $b = c + d/t$  for the quantity  $t$ .

*Solution:* Again, we first subtract the quantity  $c$  from both sides of the equation to isolate the term containing  $t$ :

$$b - c = c + \frac{d}{t} - c = \frac{d}{t}$$

The quantity  $t$  is in the denominator, however, so we multiply both sides of the equation by  $t$ :

$$(b - c)t = \frac{d}{t}t = d$$

Next, we divide both sides of the equation by  $(b - c)$  to obtain  $t$  by itself on the left side of the equation:

$$\begin{aligned} \frac{(b - c)t}{b - c} &= \frac{d}{b - c} \\ t &= \frac{d}{b - c} \end{aligned}$$

Although this is a more complex example, each of these steps has a specific objective. The first step isolates the quantity  $d/t$ , the second step removes  $t$  from the denominator so that we can more readily solve for  $t$ , and the final step leaves  $t$  by itself. These objectives must be recognized to gain confidence in performing such operations yourself. Even people who are familiar with algebra often forget just what they are trying to accomplish, or they get careless in making sure they are doing the same thing to both sides of an equation.

## Exercises

(Answers to odd-numbered exercises are found in appendix D.)

1. Solve the equation  $F = ma$  for the quantity  $a$ .
2. Solve the equation  $PV = nRT$  for the quantity  $P$ .
3. Solve the equation  $b = c + d$  for the quantity  $d$ .
4. Solve the equation  $h = g - f$  for the quantity  $g$ .
5. Solve the equation  $a = bc + d$  for the quantity  $d$ .
6. Solve the equation in exercise 5 for the quantity  $b$ .
7. Solve the equation  $a = b(c - d)$  for the quantity  $b$ .
8. Solve the equation in exercise 7 for the quantity  $c$ . (*Hint:* First rewrite the equation as  $a = bc - bd$ , multiplying both terms inside the parentheses by  $b$ . This does not change the equality.)
9. Solve the equation  $a + b = c - d$  for the quantity  $b$ .
10. Solve the equation in exercise 9 for the quantity  $c$ .
11. Solve the equation  $b(a + c) = dt$  for the quantity  $b$ .
12. Solve the equation in exercise 11 for the quantity  $c$ .
13. Solve the equation  $x = v_0t + \frac{1}{2}at^2$  for the quantity  $v_0$ .
14. Solve the equation in exercise 13 for the quantity  $a$ .

# Appendix B

## Decimal Fractions, Percentages, and Scientific Notation

In physics and many other fields in which numbers are important, we usually express fractions as decimal fractions and often use percentages as a means of expressing fractions or ratios. Because we sometimes need to deal with very large and very small numbers, we also use a means of expressing these numbers that involve powers of 10, or *scientific notation*, to avoid writing out all of the zeroes. Although scientific notation is used sparingly in this book, there are times when its use is highly desirable, if not essential, so it is important you understand its meaning. It is part of the language of science.

### Decimal Fractions

Although most college-level students are familiar with decimal fractions and percentages, they are not always completely sure of their meaning. Fractions involve ratios or proportions, which are not well understood by many people. One of the benefits of taking a course in physics is that it can strengthen your ability to think in terms of ratios or proportions and to understand how they are described.

A decimal fraction is just a fraction for which the number in the denominator is some multiple of the number 10 (10, 100, 1000, and so forth), with the appropriate multiple indicated by the location of the decimal point. For example, if we start with the fraction  $\frac{1}{2}$  and divide 1 by 2 as the fraction indicates, a calculator will display the result as 0.5. The decimal point in front of the 5 is a shorthand notation for expressing the fraction  $\frac{5}{10}$ . The number 5 is half of 10, so the fraction  $\frac{5}{10}$  is the same as the fraction  $\frac{1}{2}$  (one-half). In other words, the *ratio* of 5 to 10 is the same as the ratio of 1 to 2.

If the fraction  $\frac{3}{4}$  is evaluated on a calculator by dividing 3 by 4, the calculator will express the result as 0.75, which is equivalent to the fraction  $\frac{75}{100}$ , or 75 hundredths. Thus, the first place or number after the decimal point represents tenths, the second place hundredths, the third place thousandths, and so on. The fraction 346 thousandths ( $\frac{346}{1000}$ ) is

expressed as 0.346, for example. We could read this as 3 tenths plus 4 hundredths plus 6 thousandths.

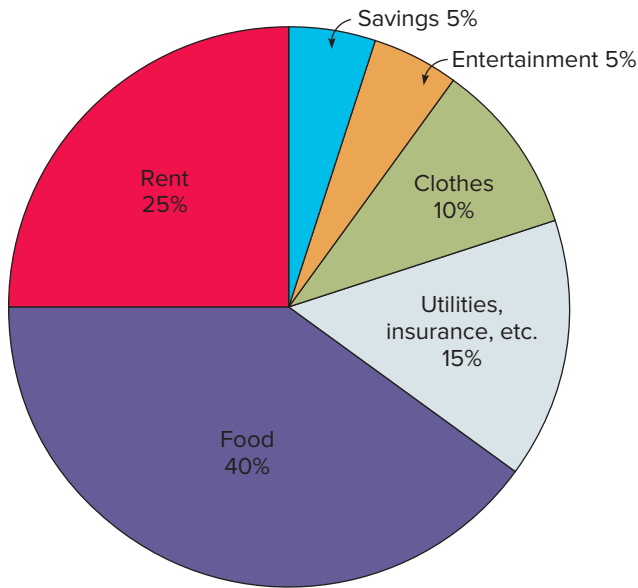
Decimal fractions are used very commonly, although we may not always stop to think about their meaning. In baseball, for example, we express a batter's hitting efficiency as a decimal fraction. A batter who has produced 35 hits in 100 official at-bats is said to be hitting .350. This is really  $\frac{350}{1000}$ , or 0.350, but the decimal point is often omitted. Most people understand that it should be there, however, and that we are merely expressing the fraction  $\frac{35}{100}$  in decimal form and including three figures to the right of the decimal point.

### What Are Percentages?

Another common way of expressing decimal fractions is to write them as percentages. The word *percent* means per one hundred, so a percentage is just a decimal fraction in which the denominator is 100. The fraction  $\frac{1}{2}$ , for example, is  $\frac{5}{10}$ , or  $\frac{50}{100}$ , and can be expressed as 50%—it is 50 hundredths. The fraction  $\frac{3}{4}$  is 0.75, or 75% (75 hundredths), and the fraction  $\frac{346}{1000}$  is 0.346, or 34.6% (34.6 hundredths). Thus, moving the decimal place two places to the right converts a decimal fraction to a percentage and is equivalent to multiplying the fraction by 100.

The use of percentages is even more common than the direct use of decimal fractions. Interest rates and tax rates are usually expressed as percentages, for example, so we should all have some understanding of their meaning. An interest rate of 7% means you will receive or pay \$7 each year for every \$100 you have invested or borrowed:  $\frac{7}{100}$  of the total amount. (We are ignoring here the possible effects of compounded interest.) A tax rate of 28% means we will owe to the government \$28 of every \$100 we earn (after deductions are subtracted). A percentage is always per one hundred, by definition.

Although it is easy enough to understand how a percentage is calculated (compute the decimal fraction and multiply by 100), having a good feeling for the



**Figure B.1** A pie chart showing the fractions of total take-home pay spent in different categories. The slices of the pie are in proportion to the percentages being represented.

proportions represented by different percentages is another matter. Pie charts, like the one shown in figure B.1, are often used to provide a visual representation of these proportions. The slices of the pie should have sizes in proportion to the percentages or fractions being represented. If the graphic artist does not understand this (as sometimes happens), the resulting pie chart may be very misleading.

The pie chart in figure B.1 represents the average monthly expenditures of someone who takes home \$2000 a month (after taxes and other deductions). If she spends \$500 a month on rent, this is  $\frac{500}{2000}$ , or 0.25 (one-quarter), of her total income. Because 0.25 equals 25%, this is shown as 25% on the pie chart, and it takes up one-quarter of the total pie or circle. The size of the slice is in proportion to the percentage. Likewise, if she spends \$800 a month on food, this is  $\frac{800}{2000}$ , or 0.40, which is 40% of her total take-home pay. The other slices represent smaller percentages and have correspondingly smaller sizes. If we have taken into account all of her normal expenses, the sum of the percentages in the chart should add to 100%.

### Why Is Scientific Notation Used?

When we need to represent very large numbers or very tiny fractions, a lot of zeroes are required to locate the decimal point properly. For example, 5 trillion (the fastest camera in the world can shoot 5 trillion frames a second) can be written as

$$5,000,000,000,000$$

The zeroes are there only to locate the decimal point; they do not imply that all of the other numbers to the right of the 5 are exactly zero. If we count the digits to the right of the 5, we see that there are 12 (12 zeroes).

Another way of stating this number would be to say it is 5 times 1 trillion, where 1 trillion is the number 1 followed by 12 zeroes. One trillion is also the number that results when you multiply 1 by 10 a total of 12 times.

$$1,000,000,000,000 = 1 \times 10 \times 10 \times 10 \times 10 \\ \times 10 \times 10 \times 10 \times 10 \\ \times 10 \times 10 \times 10 \times 10$$

The shorthand notation for a number multiplied by itself 12 times is to say that it has been raised to the *power* 12, which we write as  $10^{12}$ . The superscript represents the power to which the number has been raised, which is the number of times you have multiplied the number by itself. We read this number as “10 to the twelfth power” or often just “10 to the twelfth.”

Thus, we can write the number 5 trillion as

$$5.0 \times 10^{12}$$

This notation, in which we have written the number as some number times a power of 10, is called *scientific notation*. The number 12 (the power) simply tells us how many places to the right of the indicated decimal point we would move the decimal point if we wrote out all of the zeroes. Scientific notation has several advantages: It saves space, it properly indicates the accuracy or precision of the number being represented by eliminating the zeroes, and it makes the number easier to manipulate in calculations involving very large or small numbers.

Some examples involving smaller numbers may help to make the concept clear. The number 586, to choose a much smaller number than 1.2 trillion, can be expressed as 5.86 times 100, or  $5.86 \times 10^2$ , because  $10 \times 10 = 100 = 10^2$  (10 squared). The number 6180 can be expressed as  $6.18 \times 10^3$ , because  $10^3$  (10 cubed) is 1000. The number 5,400,000 (5.4 million) can be expressed as  $5.4 \times 10^6$ , because 10 to the sixth power is 1 million. Several other examples are provided in table B.1. The last number listed under the positive powers of 10 is the approximate mass of the Earth in kilograms.

Table B.1 also shows several decimal fractions written in scientific notation. A fraction will always have a negative exponent (negative power of 10) if the value of the fraction is less than 1. For example, the fraction 0.0000000000054 is the very tiny fraction 5.4 trillionths. It can be expressed as  $5.4 \times 10^{-12}$ , which is equivalent to dividing the number 5.4 by  $10^{12}$ , or by 1 trillion. The superscript  $-12$  tells you that you have to move the decimal point 12 places to the *left* to express the number in normal decimal form.

In a simpler example, the decimal fraction 0.0346 is  $3.46 \times 10^{-2}$ , or 3.46 hundredths. Moving the decimal points two places to the left, as indicated by the power of 10, yields the original decimal fraction. The fraction

Table B.1

Examples of Scientific Notation		
Positive Powers of 10		
5460	= 5.46 times 1 thousand	= $5.46 \times 10^3$
23,400	= 23.4 times 10 thousand	= $2.34 \times 10^4$
6,700,000	= 6.7 times 1 million	= $6.7 \times 10^6$
9,400,000,000	= 9.4 times 1 billion	= $9.4 \times 10^9$
5,980,000,000,000,000,000,000,000		= $5.98 \times 10^{24}$
Negative Powers of 10 (Fractions)		
0.62	= 6.2 times one-tenth	= $6.2 \times 10^{-1}$
0.0523	= 5.23 times one-hundredth	= $5.23 \times 10^{-2}$
0.0082	= 8.2 times one-thousandth	= $8.2 \times 10^{-3}$
0.0000024	= 2.4 times one-millionth	= $2.4 \times 10^{-6}$
0.000000079	= 7.9 times one-billionth	= $7.9 \times 10^{-9}$
0.000000000000000000016		= $1.6 \times 10^{-19}$

0.0079 is 7.9 thousandths, or  $7.9 \times 10^{-3}$ . Studying the other examples in table B.1 should make the pattern clear. The last number in table B.1 is the value of the charge on the electron in coulombs, a quantity that arises frequently in modern physics.

The prefixes used in the metric system of units (discussed in chapter 1) are another aid to expressing very large or very small numbers. Because the prefix *mega* stands for 1 million, the quantity 1.35 Mg (megagrams) is the same as  $1.35 \times 10^6$  g ( $10^6$  is 1 million). Likewise, 780 nm (nanometers) is the same as  $780 \times 10^{-9}$  m, because the prefix *nano* means one-billionth, or  $10^{-9}$ . The values of the commonly used metric prefixes are found in table 1.3 in chapter 1. These metric prefixes and the power-of-10 scientific notation are both types of scientific shorthand used to express numbers in briefer forms.

## Multiplying and Dividing Using Powers of 10

The process of multiplying or dividing numbers written in power-of-10 notation is straightforward if you understand what they mean. It is even easier if you have a calculator that handles scientific notation—you just punch the numbers in and push the appropriate function key. Some understanding of their meaning, though, can be useful for checking your results.

Suppose, for example, that we multiply the number  $3.4 \times 10^3$  (3400) by 100 ( $10^2$ ). Multiplying by 100 adds two zeroes to the original number, yielding 340,000, as you can quickly check by doing this operation on a calculator or by direct multiplication. Thus,

$$(3.4 \times 10^3) \times (10^2) = 3.4 \times 10^5$$

In other words, the powers of 10 add ( $3 + 2 = 5$ ). If we divided by 100, we would remove two zeroes:

$$\frac{3.4 \times 10^3}{10^2} = 3.4 \times 10^1 = 34$$

In this case, the exponent of the denominator is subtracted from the exponent of the number being divided ( $3 - 2 = 1$ ).

The rules for these operations are thus

1. When numbers are multiplied, the powers of 10 add.
2. When numbers are divided, the power of the denominator is subtracted from the power of the numerator.

These rules are valid regardless of whether the powers are positive or negative. Thus,

$$(3 \times 10^6) \times (2 \times 10^{-4}) = 6 \times 10^2 = 600$$

because  $6 + (-4) = 2$ . This should make sense to you because multiplying by a fraction (a number with a negative power of 10) results in a smaller number than the number being multiplied.

## Exercises

If any of these ideas are unfamiliar—or even if they are familiar but you are rusty in using them—working some or all of these exercises will help to build your confidence. The answers to the odd-numbered exercises are found in appendix D.

(Exercises 1 through 4) Express these numbers as decimal fractions:

1. a.  $\frac{6}{10}$    b.  $\frac{52}{100}$    c.  $\frac{874}{1000}$    d.  $\frac{5}{10\,000}$
2. a.  $\frac{72}{100}$    b.  $\frac{7}{10}$    c.  $\frac{83}{10\,000}$    d.  $\frac{45}{1000}$
3. a.  $\frac{1}{4}$    b.  $\frac{5}{8}$    c.  $\frac{16}{52}$    d.  $\frac{312}{914}$  (Use a calculator.)
4. a.  $\frac{3}{7}$    b.  $\frac{11}{15}$    c.  $\frac{147}{654}$    d.  $\frac{65}{150}$  (Use a calculator.)
5. Express the fractions in exercise 3 as percentages.
6. Express the fractions in exercise 4 as percentages.
7. Find: a. 50% of 105   b. 75% of 48  
c. 60% of 180   d. 85.2% of 100
8. Find: a. 40% of 120   b. 90% of 400  
c. 33.3% of 90   d. 70% of 540

(Exercises 9 through 12) Express these numbers in scientific notation (power-of-10 notation):

9. a. 5475   b. 200,000   c. 67,000   d. 35,000,000,000
10. a. 3560   b. 78,500   c. 622,000   d. 9,100,000
11. a. 0.0065   b. 0.000333   c. 0.0000015  
d. 0.000000065
12. a. 0.075   b. 0.00045   c. 0.0000032   d. 0.00089

13. Express these numbers as decimal fractions.

- a.**  $6.7 \times 10^{-3}$       **b.**  $1.8 \times 10^{-4}$   
**c.**  $5.77 \times 10^{-6}$     **d.**  $3.25 \times 10^{-5}$

14. Perform these operations:

- a.**  $(3.0 \times 10^2) \times (4.3 \times 10^5)$   
**b.**  $(7.5 \times 10^3) \times (5.0 \times 10^6)$   
**c.**  $(4.0 \times 10^8) \times (5.4 \times 10^{-5})$   
**d.**  $(6.0 \times 10^8) \div (2.0 \times 10^3)$

15. Perform these operations:

- a.**  $(3.0 \times 10^5) \times (2.0 \times 10^4)$   
**b.**  $(4.0 \times 10^7) \times (6.0 \times 10^{-3})$   
**c.**  $\frac{3.6 \times 10^8}{2.0 \times 10^5}$   
**d.**  $\frac{3.6 \times 10^{12}}{2.0 \times 10^{-6}}$

# Appendix C

## Vectors and Vector Addition

**M**any of the quantities we encounter in the study of physics are vector quantities, which is to say that their *direction* is important, as well as their size or magnitude. Examples of vector quantities include velocity and acceleration (introduced in chapter 2), as well as force, momentum, electric field, and many others encountered in later chapters. Direction is an essential feature of these quantities: The result of traveling with a velocity of 20 m/s due north is very different from that of traveling with a velocity of 20 m/s due east.

Quantities for which direction is not an essential feature (or for which direction has no meaning at all) are called *scalar* quantities. Mass, volume, and temperature are examples of scalar quantities—it makes no sense to talk about the direction of a volume or a mass. Specifying the magnitude (the numerical value with appropriate units) of a scalar quantity is sufficient; no other information is needed. Vectors, on the other hand, require at least two pieces of information to describe both their size and their direction.

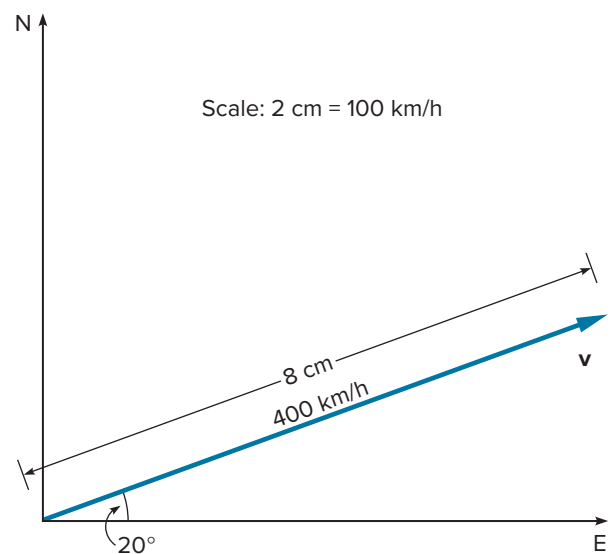
### How Do We Describe a Vector?

Suppose we wish to describe the velocity of an airplane flying in a direction somewhat north of due east. The magnitude of the airplane's velocity can be specified by stating its speed as 400 km/h, for example. The direction of the airplane's velocity can be specified in a number of ways, but the simplest would be to specify an angle to some reference direction— $20^\circ$  north of east, for example. These two numbers, 400 km/h and  $20^\circ$  north of east, are sufficient to describe the airplane's velocity, provided that its motion is two-dimensional (in a horizontal plane, not climbing or descending). If the plane is climbing or descending, a second angle, the angle of ascent or descent, must also be specified.

A diagram is often a more vivid way of describing this vector. Figure C.1 shows the velocity of the airplane as an arrow, pointed in a direction  $20^\circ$  north of east. The

magnitude of the velocity can be represented by the length of the arrow if we choose an appropriate scale factor when drawing the diagram. For example, if 2 cm were selected to represent 100 km/h, then we would draw the arrow with a length of 8 cm ( $4 \times 2$  cm) to represent the speed of 400 km/h. A smaller speed would be represented by a shorter arrow, and a larger speed would require a longer arrow.

An arrow is the universal symbol for representing vectors on diagrams. An arrow can clearly indicate direction and can also be drawn to different lengths to indicate magnitude. We often use boldface type for the symbols that represent vector quantities: The symbol  $\mathbf{v}$  tells us that we are dealing with the vector quantity, velocity. The symbol  $v$ , on the other hand, often represents the scalar quantity, speed.



**Figure C.1** The velocity vector of 400 km/h in the direction  $20^\circ$  north of east is represented by drawing the arrow to scale (2 cm = 100 km/h) and at the appropriate angle ( $20^\circ$ ).



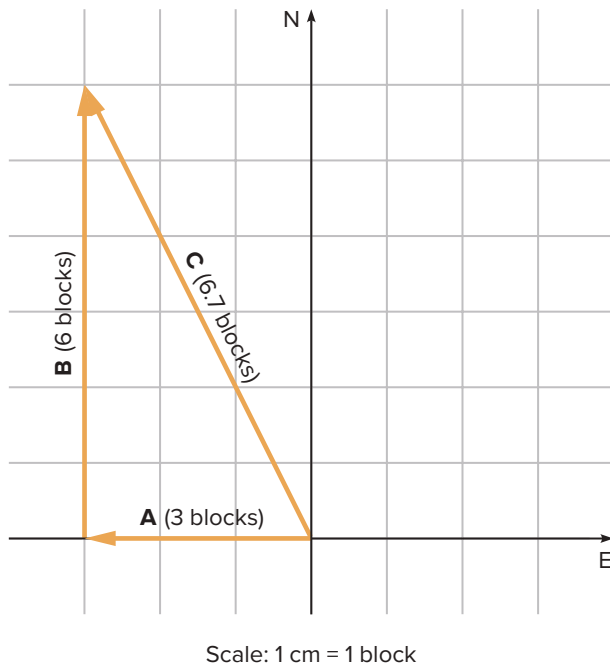
## How Do We Add Vectors?

We are often interested in the net result of combining two or more vectors. In chapter 4, for example, *net force* determines the acceleration of an object. This net force is the vector sum of whatever forces are acting on the object, which can include several forces. As a second example, an airplane’s velocity relative to the ground is determined by the vector sum of its velocity relative to the air and the velocity of the air relative to the ground (the wind velocity), as discussed in chapter 20.

One of the most readily visualized examples of vector addition involves *displacements* of moving objects. Suppose, for example, that a student wishes to travel to an apartment complex located on North Main Street, a few blocks north and west of campus. One way she might get there from a starting point on the south side of campus is to walk three blocks due west along Pacific Avenue, then six blocks due north along Main Street, as indicated in figure C.2. The result of these two motions can be represented by displacement vectors; the first motion displaces her three blocks due west, the second one six blocks due north.

The two displacements just described are drawn to scale and in the appropriate direction in figure C.2 (1 cm = 1 block on the drawing). The result of these combined motions is indicated by drawing displacement **C**, which is the vector drawn from the starting point to the final destination. Vector **C** is thus the vector sum of vectors **A** and **B**:

$$\mathbf{C} = \mathbf{A} + \mathbf{B}$$



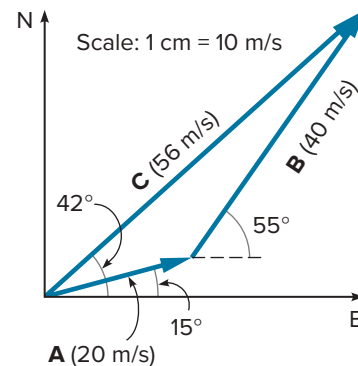
**Figure C.2** The net result of adding displacement **A** (three blocks due west) and displacement **B** (six blocks due north) is displacement **C**, obtained by drawing a vector from the starting point to the final destination.

The sum combines their individual effects into a single net displacement. The length of vector **C** is approximately 6.7 cm, which represents a distance of 6.7 blocks, given the scale factor used in drawing the diagram. Measuring the angle with a protractor yields an angle of approximately 27° west of north for the displacement vector **C**.

This process of vector addition we have just described can be used with any vectors. It is often referred to as the *graphical method* of adding vectors or, more descriptively, as the *tail-to-head technique*. Its steps are as follows:

1. Draw the first vector to scale (1 cm equals so many units of the vector quantity) and in the appropriate direction using a ruler and a protractor.
2. Starting the second vector with its tail placed at the head of the first vector, draw the second vector to scale and in the appropriate direction.
3. If more than two vectors are involved, draw the succeeding vectors to scale and in the appropriate direction, starting each vector with its tail at the head of the previous vector.
4. To obtain the vector sum, draw a vector from the tail of the first vector to the head of the final vector. Measure the angle this vector makes to some reference direction with the protractor, and measure its length with a ruler. These two measurements represent the direction and magnitude of the vector sum. (The measured length must be multiplied by the scale factor used in drawing the original vectors to obtain the appropriate units.)

To illustrate this process in another example, we have added two velocity vectors in figure C.3. The first vector **A** is a velocity of 20 m/s at an angle of 15° north of east. The second vector **B** is a velocity of 40 m/s at an angle of 55° north of east. They have each been drawn to a scale of 1 cm = 10 m/s, so vector **A** is 2 cm long and vector **B** is 4 cm long. The tail of vector **B** is placed at the head or tip of vector **A** to add the vectors. The resulting sum, vector **C**, is



**Figure C.3** The velocity vectors **A** and **B** are added to obtain the vector sum **C**. A scale factor of 1 cm = 10 m/s is used, and the tail of vector **B** is placed at the head of vector **A**.

approximately 5.6 cm long, determined by measuring with a ruler. Using the scale factor of  $1 \text{ cm} = 10 \text{ m/s}$ , we have

$$5.6 \text{ cm} \times (10 \text{ m/s per cm}) = 56 \text{ m/s}$$

Measuring the angle that **C** makes to the horizontal axis (east), we find that **C** is approximately  $42^\circ$  north of east. Thus, the vector sum of vectors **A** and **B** is equal to  $56 \text{ m/s}$  at an angle of  $42^\circ$  north of east.

Note that in both this example (involving velocities) and the previous example (involving displacements), the magnitude of the vector sum is not equal to the sum of the magnitudes of the two vectors being added. In the first case, the vector sum **C** had a magnitude of 6.7 blocks, which is less than the 9 blocks ( $3 + 6$ ) that the student actually walked. In the velocity example, the vector sum has a magnitude of  $56 \text{ m/s}$ , less than the sum of  $60 \text{ m/s}$  obtained by adding the magnitudes of vectors **A** and **B**. This is a general feature of the process of vector addition. The *only* case in which the magnitude of the vector sum equals the sum of the magnitudes of the vectors being added ( $A + B$ ) is when these vectors are in the same direction.

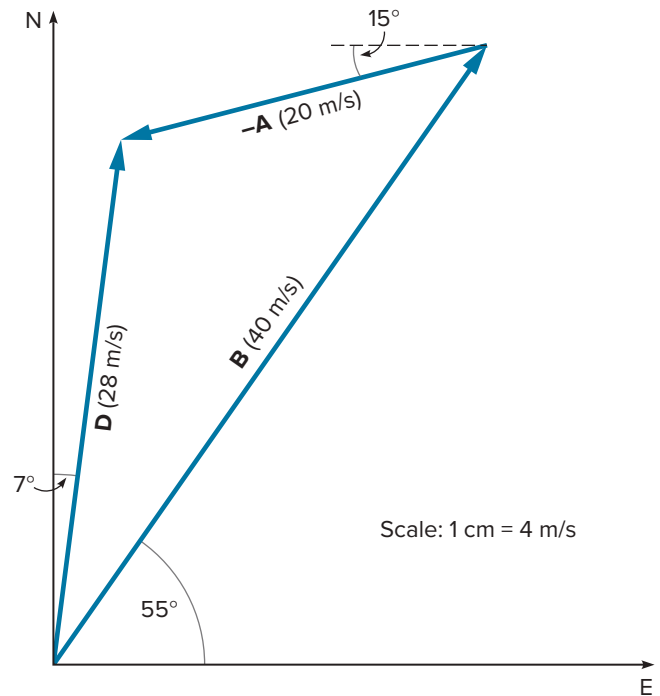
### How Do We Subtract Vectors?

Once you have mastered the concept of vector addition, subtraction represents a straightforward extension of these ideas. Subtraction can always be represented as the process of adding to the original quantity the *minus* value (the negative) of the quantity being subtracted. Thus, the process of subtracting 2 from 6 is the same as adding  $-2$  to 6. If we want to subtract vector **A** from vector **B** to get the vector difference  $\mathbf{B} - \mathbf{A}$ , we add  $-\mathbf{A}$  to **B**. To get the negative of a vector, we reverse its direction.

To illustrate this process, we have subtracted velocity **A** from velocity **B** in figure C.4, using the same two vectors we added in figure C.3. However, we are using a different scaling factor:  $1 \text{ cm} = 4 \text{ m/s}$ . Vector **B** will thus be 10 cm long [ $(40 \text{ m/s}) / (4 \text{ m/s per cm}) = 10 \text{ cm}$ ] and vector **A** will be 5 cm long. We first draw vector **B** to scale and then add to it the negative of vector **A**. Note that we have reversed the direction of **A** to get  $-\mathbf{A}$ . The negative vector is  $15^\circ$  below the westward horizontal, instead of  $15^\circ$  above the eastward horizontal. The difference vector **D** is then obtained by drawing the vector from the tail of the first vector (**B**) to the head of the second ( $-\mathbf{A}$ ). The vector **D** has a length of approximately 7.0 cm and makes an angle of approximately  $7^\circ$  to the vertical axis (north). The length of 7.0 cm represents a velocity of  $28 \text{ m/s}$  ( $7.0 \text{ cm} \times 4 \text{ m/s per 1 cm}$ ), because this is the scale factor used in figure C.4.

### What Are Vector Components?

We often find it useful to describe vectors in terms of their horizontal and vertical *components*, rather than directly dealing with the entire vector. This is particularly true when we are discussing projectile motion, as in chapter 3, but it is also useful for computing work (chapter 6) and in many other applications.

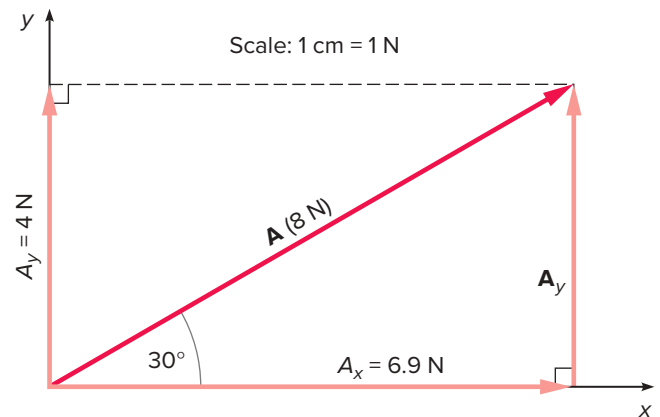


**Figure C.4** The velocity vector **A** is subtracted from the velocity vector **B** to obtain the difference vector **D**. The scale is  $1 \text{ cm} = 4 \text{ m/s}$ .

The components of a vector are any two (or more) vectors that when added together yield the vector of interest.

It is usually most productive to define these components as perpendicular to one another, often in the horizontal and vertical directions.

We can use graphical techniques to find the components of a vector, as well as to add or subtract vectors. The process is illustrated for a force vector in figure C.5. The force vector **A** has a magnitude of 8 N and a direction of  $30^\circ$  above the



**Figure C.5** The components of the force vector **A** are found by drawing the vector to scale and then drawing lines from the tip of the vector to the  $x$  and  $y$  axes, so that these lines make right angles ( $90^\circ$ ) with the axes.

horizontal. (The newton, N, is the metric unit of force.) Our first step in finding the horizontal and vertical components of this vector is to draw the vector to scale (1 cm = 1 N) and in the appropriate direction (30° above the horizontal) using a ruler and a protractor, as before.

The horizontal component of the vector **A** is then found by drawing a line from the tip of **A** to the horizontal ( $x$ ) axis, such that the line makes a right angle with (is perpendicular to) the  $x$ -axis. The distance along the  $x$ -axis measured from the tail of **A** (the origin) to the point where the perpendicular line meets the axis represents the magnitude of  $A_x$ , the horizontal component of **A**. The magnitude  $A_x$  is the portion of **A** that is in the horizontal direction.

A similar process yields  $A_y$ , the vertical component of **A**, but in this case, a dashed line is drawn from the tip of **A** to the vertical ( $y$ ) axis, making a right angle to the vertical axis. Measuring the lengths of these components with a ruler yields magnitudes of 6.9 N (6.9 cm on the graph) and 4 N (4 cm on the graph) for  $A_x$  and  $A_y$ , respectively.

If we treat these two components of **A** as vectors and add them together in the usual tail-to-head manner, we obtain the original vector **A**, as shown in figure C.5. We can therefore use these two components to represent the vector, because, added together, they are identical to the original vector. Very often, however, we are really interested in only the horizontal effect or the vertical effect of the vector, and then we use just one of the components by itself. In the case of a force vector, for example, the effect of the force in moving an object in the horizontal direction will be determined by the horizontal component of the force vector, rather than by the total vector. In projectile motion, it is the horizontal component of the velocity that determines how far the object will travel horizontally in a given time, and so on.

The components of vectors can also be used in adding or subtracting vectors, as well as for many other purposes. In this book, however, our main use of the concept of vector components is to break down a vector into its horizontal and vertical portions for the purpose of analyzing the horizontal

and vertical motions separately. Knowing that this can be done is key to your understanding of projectile motion and many other physical processes.

## Exercises

(Answers to the odd-numbered exercises are found in appendix D.)

Use the graphical tail-to-head technique to find the vector sums of the indicated vectors in exercises 1 through 4.

- Vector **A** = a displacement of 20 m due east  
Vector **B** = a displacement of 30 m due north
- Vector **A** = a velocity of 20 m/s at 30° north of east  
Vector **B** = a velocity of 50 m/s at 45° north of east
- Vector **A** = an acceleration of 4 m/s<sup>2</sup> due east  
Vector **B** = an acceleration of 3 m/s<sup>2</sup> at 40° north of east
- Vector **A** = a force of 20 N at 45° above the horizontal (to the right)  
Vector **B** = a force of 30 N at 20° to the left of vertical
- Find the magnitude and direction of the difference vector **B** – **A** in exercise 1.
- Find the magnitude and direction of the difference vector **A** – **B** in exercise 1.
- Find the magnitude and direction of the difference vector **A** – **B** in exercise 2.
- Find the magnitude and direction of the difference vector **A** – **B** in exercise 3.
- Find the east and north components ( $x$  and  $y$ ) of vector **A** in exercise 2.
- Find the horizontal and vertical components of vector **A** in exercise 4.
- Find the horizontal and vertical components of vector **B** in exercise 4.

# Appendix D

## Answers to Selected Questions, Exercises, and Synthesis Problems

(Others will be available as a “Student Resource” on the Connect instructor resources and may be provided at your instructor’s discretion.)

### Chapter 1

**Q3.** No. The burning of wood represents the use of plants that have recently absorbed carbon from the atmosphere; the net effect of burning wood has little or no impact on carbon dioxide levels.

**Q9.** No. The conditions for historical observations cannot be repeated or controlled in the manner of a physical experiment.

**Q15.** Optics, the study of light, explains the production of rainbows. Mechanics explains the fall of an acorn.

**Q21.** The advantage of continuing to use the English system, besides its familiarity, is that it avoids retraining workers and revising standards and publications.

**E1.** 124 grams **E3.** 5 pizzas **E5.** 105 in, or 8.75 ft  
**E7.** 8300 g, 8.3 kg **E9.** 1610 m, or 1.61 km  
**E11.** 52 800 cm<sup>2</sup>, 10 000 cm<sup>2</sup> **E13.** \$4.54/gal **E15.** 4

**SP3.** **a.** 1750 hrs **b.** 175 kWh **c.** 38.5 kWh **d.** \$26.25  
**e.** \$5.78 **f.** \$20.48 per year **g.** \$409.50 per year

### Chapter 2

**Q9.** The vehicle density is the number of vehicles per mile and is a property of several vehicles. It has nothing to do with vehicle weight.

**Q15.** No. When a ball is dropped, it moves in a constant direction (downward), but the magnitude of its velocity (speed) increases as it accelerates due to gravity.

**Q21. a.** Yes. Constant velocity is represented by the horizontal line from  $t = 0$  seconds to  $t = 2$  seconds, which indicates the velocity does not change.

**b.** Acceleration is greatest between 2 and 4 seconds, where the slope of the graph is steepest.

**Q27.** No. This relationship holds only when the acceleration is constant.

**Q33.** The second runner. If both runners cover the same distance in the same time interval, then their average velocity has to be the same and the area under the curves on a velocity-time graph are the same. If the first runner reaches maximum speed quicker, the only way the areas can be equal is if the second runner reaches a higher maximum speed, which he then maintains over a shorter portion of the interval.

**E1.** 59 MPH **E3.** 0.37 cm/day **E5.** 360 s, 6 min  
**E7.** 7.02 km **E9.** 104.6 km/h **E11.**  $-2 \text{ m/s}^2$   
**E13.** 10.8 m/s **E15. a.** 2.7 m/s **b.** 3.8 m  
**E17. a.** 0.8 m/s **b.** 4.8 m **E19.** 45.8 s  
**E21. a.** Speed: 68 m/s, 46 m/s, 24 m/s, 2 m/s  
**b.** Distance: 158 m, 272 m, 342 m, 368 m

**SP1. a.** 22 s **SP5. a.** Car A: 2.1 m, 8.4 m, 18.9 m, 33.6 m;  
Car B: 7 m, 14 m, 21 m, 28 m **b.** 3.3 s

### Chapter 3

**Q3.** Yes. Both balls are accelerated, because their velocity is changing. Ball A has an increasing velocity, and ball B has a decreasing velocity (negative acceleration).

**Q9.** No. Constant acceleration would require the  $v$  vs.  $t$  curve to be a straight line. Since the given velocity vs. time graph has an increasing slope with increasing time, it follows that the object has positive acceleration.

**Q15.** This graph is a straight line with a negative slope of  $-10 \text{ m/s}^2$ . It starts with a positive value of velocity and continually decreases, keeping the same negative slope throughout. The velocity changes direction at the top of its trajectory, where the velocity is momentarily zero. This is at the point on the graph where the velocity is zero, where it crosses the  $x$  axis.

**Q21.** The rolled ball has the larger velocity. In addition to the vertical component (which is the same as that of the dropped ball), it has a horizontal component that the dropped ball lacks.

**Q27.** As there is always a horizontal velocity component not equal to zero, there is no time when the velocity of the ball is equal to zero for either of the shown trajectories.

**Q33.** The projection of the hoop's area perpendicular to the ball's trajectory is smaller when the angle of approach is relatively horizontal, diminishing the leeway for the ball to pass through. A steeper shot maximizes the area of the hoop seen by the ball as it approaches, allowing greater flexibility in the launching angles associated with success.

**E1.** a. 7 m/s b. 14 m/s **E3.** a. 2.45 m b. 9.8 m  
**E5.** 44 m/s **E7.** a. +3 m/s (up) b. -7 m/s (down)  
**E9.** 1.3 s **E11.** a. 0.25 s b. 31.25 cm **E13.** 1.01 m  
**E15.** a. 0.77 s b. 3.87 m

**SP1.** a. 0 b. 1.8 s c. 16.2 m d. 9 m e. down  
**SP3.** a. 0.37 s b. Ball A: 1.5 m, Ball B: 2.2 m c. no  
**SP5.** a. 44.7 m/s b. 18.3 m c. 0.409 s d. 0.84 m e. 2.76 ft

## Chapter 4

**Q3.** Aristotle suggested that as the ball moves forward, air rushes around the ball to fill the void left by the ball's previous position, and this air pushes the ball from behind.

**Q9.** Yes. The ball could be moving with constant velocity, but it is not accelerating when the net force is zero.

**Q15.** No. The mass is a property of the object that does not depend on where the object is located. Weight is a force that depends on the local value of  $g$ , the acceleration due to gravity.

**Q21.** The external force that pushes the car forward is the frictional force exerted by the road on the tires, which is a third-law reaction to the force the tires exert on the road.

**Q27.** Yes. The mule can accelerate the cart, assuming said mule is strong enough to impart a horizontal component of force that will overcome the horizontal frictional force necessary to get the cart wheels moving.

**Q33. a.** They will move not with constant velocity but with constantly increasing velocity. The applied force is constant, and this implies a constant acceleration. Constant acceleration results in constantly increasing velocity.

**b.** The tension in the connecting string is less than  $F$ . Both bodies have the same acceleration. The force  $F$  accelerates a total mass,  $2m$ . The force in the connecting string accelerates a mass,  $m$ , so it is half of  $F$ .

**Q39.** The carts all move at the same speed and have the same acceleration, so the force needed to move the carts is proportional to their masses. The net force on each cart is proportional to the mass because the acceleration  $\mathbf{a} = \mathbf{F}/m$  is the same for each cart.

**E1.** 7 m/s<sup>2</sup> **E3.** 8.0 kg **E5.** 9.0 m/s<sup>2</sup> **E7.** 8 kg  
**E9.** a. 3.6 N b. 0.40 m/s<sup>2</sup> **E11.** 75 kg **E13.** a. 67.3 kg  
b. 148.3 lb **E15.** a. 58.8 N b. 46.8 N c. 7.8 m/s<sup>2</sup>, downward  
**E17.** a. Net force = zero. It is not accelerating; it is at rest.  
b. 7.84 N (if use  $g = 9.8$  m/s/s), 8 N (if use  $g = 10$  m/s/s)  
c. 19.84 N (if  $g = 9.8$  m/s/s), 20 N (if  $g = 10$  m/s/s), no, it is not accelerated **E19.** a. +45 N b. -735 N c. +780 N

**SP1.** a. 2.75 m/s<sup>2</sup> b. 8.25 m/s c. 12.4 m **SP3.** a. 0.60 m/s<sup>2</sup>  
b. 0.120 m/s c. 1.2 cm **SP5.** a. 32 N b. 3.2 m/s<sup>2</sup> c. 15.6 N  
d. 22.4 N, 3.2 m/s<sup>2</sup>. Notice that the acceleration is the same as in part b. **SP7.** a. 550 N b. 6.34 m/s<sup>2</sup> c. 85 m/s

## Chapter 5

**Q3.** The faster car experiences the larger change of velocity. In subtracting the initial velocity vector from the final velocity vector, the longer length of the velocity vectors for the faster car produces a larger  $\Delta\mathbf{v}$ .

**Q9. b.** The direction of the net force must be toward the center of the curve to produce the centripetal acceleration.

**Q15.** No. According to Newton's first law, an object in motion will stay in motion unless acted upon by a net force. In a head-on collision the driver continues to move forward (until impact) in the absence of any force. The car does have a net force applied to it, so it stops, but the driver continues to move forward.

**Q21.** The two points where the string is attached must be moved together, so that they coincide to produce a circle, which is a special case of an ellipse.

**Q27.** No. A star cannot be visible inside the completed disc of the moon because the moon is closer to the Earth than any star and would block the light coming from the star.

**Q33.** Yes. Kepler's third law is valid for the moon, but the numerical constant in the law will be different from that for the planets' orbits about the sun.

**E1.** 20.0 m/s<sup>2</sup> **E3.** 1.8 m **E5.** 1.75 N **E7.** a. 11.4 m/s<sup>2</sup>  
b. 14.8 kN **E9.** 1/365 **E11.** 0.60 N **E13.** 1.12 N  
**E15.** 383 lb

**SP1.** a. 20.0 m/s<sup>2</sup> b. 5.00 N c. 2.45 N d. Total tension is approximately 5.6 N **SP3.** a. 12.5 m/s<sup>2</sup> b. 13.75 kN  
c. 10.8 kN d. about 11 kN e. No, because 2.3 kN < 13.75 kN  
**SP5.** a.  $3.53 \times 10^{22}$  N b.  $2.01 \times 10^{20}$  N c. 175/1; no  
d.  $4.34 \times 10^{20}$  N; yes

## Chapter 6

**Q3. a.** Yes. The block moves a distance  $d$  under the influence of the force, so work is done by the force. Note that because the object is not accelerating, there is another force present, most likely friction.

**b.** No. Only the horizontal component of the force (that in the direction of the motion) does work on the block.

**Q9.** The work done by the person can never be less than the work done by the lever on the rock. If there are no dissipative forces, they will be equal. This is a consequence of the conservation of energy.

**Q15.** Yes. The work done results in an increase in potential energy.

**Q21.** The chin will be in great danger! The kinetic energy added by the push increases the total energy of the system, so the ball will swing back farther.

**Q27. a.** Yes. The energy from burning the oil goes into heating the air and our hands. No energy has been lost.  
**b.** We are wasting a lot of the heat generated from a high-grade source of energy just to heat the atmosphere, and we are polluting the atmosphere.

\***Q33.** The cocking of the dart gun adds elastic potential energy to the system. The dart is then released, so the elastic potential energy is converted to kinetic energy for the time the dart is in contact with the spring. Then, the kinetic energy of the dart is converted into potential energy, slowing the dart as it rises toward the ceiling. Also, there is the transformation of kinetic energy into heat due to the frictional force of the air.

**E1.** 60 J **E3.** 4 m **E5. a.** 200 J **b.** 0 **c.** 200 J **E7. a.** 60 J **b.** 60 J **E9.** 0.17 kJ **E11. a.** 88.2 J **b.** 90 J **c.** accelerating the rock **E13.** 90 J **E15.** 470 kJ **E17. a.** 52.9 J **b.** 52.9 J **E19.** 0.0625 s

**SP1. a.** 10.2 J **b.** 6.8 J **c.** 6.8 J. The net force (4 N) creates net work, which increases the kinetic energy by  $F \times d$ .  
**d.** Three-fifths of it goes into changing the KE. The rest is converted to thermal energy. Yes. It can all be accounted for. Energy is always conserved when we include all forms of energy. **e.** 6.8 J, 5.98 m/s **SP3. a.** 31.5 J **b.** 31.5 J **c.** 39.7 m/s **d.** No, the rock will not reach these maximum values. Yes, since the band is moving it will gain some small kinetic energy. **SP5. a.** Yes. The difference between the potential energy at the first point and the second point is 6860 J, whereas the loss of energy due to friction is only 3600 J.  
**b.** 34.7 m ( $mgh_1 - \text{work due to friction} = mgh_2$ , solve for  $h_2$ )

## Chapter 7

**Q3.** Yes. Because momentum is the product of mass and velocity, a large velocity for the baseball can produce a momentum equal to that of a slower-moving bowling ball.

**Q9.** The air bag increases the time involved in the change of momentum of the automobile passenger. Because impulse is the product of force and time, a smaller force is then exerted on the passenger to produce the impulse needed to change her momentum. A smaller force will produce less severe injuries.

**Q15.** No. Momentum is not conserved, because there is a net force on the ball, which is the component of weight along the incline.

**Q21.** If free to move, both shotguns will possess the same momentum upon recoiling. The lighter one will recoil faster. The impulse delivered to the shooter's shoulder will be the same for both.

**Q27.** The skateboard will slow down. By adding the mass of the skateboarder to that of the skateboard, the total mass of the system will increase. By conservation of momentum, if the mass increases, the velocity must decrease in order for the momentum ( $mv$ ) to remain constant.

**Q33.** Yes. The collision is elastic. There has been no change in the kinetic energy of the system.

**E1. a.** 14.4 N·s **b.** 14.4 kg·m/s **E3.** the bowling ball **E5.** 5.6 N·s **E7. a.** 1725 N·s **b.** 5750 N **E9. a.** -9.4 kg·m/s

**b.** -9.4 N·s **E11. a.** 0 **b.** 6.5 m/s **E13.** 27,000 kg·m/s **E15. a.** 810 kJ **b.** 162 kJ **c.** no **E19. a.** 3.33 m/s **b.** Final speed is greater than the final speed in a head-on collision.

**SP1. a.** 14.9 kg·m/s **b.** yes **c.** 14.9 N·s **d.** 2982 N

**SP3. a.** case B **b.** case B **c.** For the ball alone, momentum is not conserved, because direction changes. For the system of ball plus wall attached to the earth, momentum is conserved in both cases. **SP5. a.** 24,000 kg·m/s, west **b.** 3.75 m/s, west **c.** 1260 kJ **d.** 45 kJ **e.** no, since KE is not conserved

## Chapter 8

**Q3.** Yes. As the coin gains linear velocity while rolling down the inclined plane, it also gains rotational velocity. Because the rotational velocity is increasing, there is a rotational acceleration.

**Q9.** The force applied at the end of the handle produces a greater torque, because it has a larger lever arm than the force applied at the middle of the handle.

**Q15.** No. The center of gravity of the pencil must be located at the fulcrum in order for the pencil to be balanced. Therefore, the center of gravity lies two-thirds the distance from the end of the pencil.

**Q21.** Yes. The rotational inertia depends on how the mass is distributed about the axis of rotation, so the same mass can result in a different rotational inertia if it is distributed differently.

**Q27.** The rotational velocity will decrease. The additional mass of the child jumping on increases the rotational inertia of the system. A larger rotational inertia implies a smaller rotational velocity in order for the angular momentum to be conserved.

**Q33.** By definition, the counterclockwise direction as viewed from above results in the rotational velocity vector pointing upward. Therefore, the angular momentum vector is pointing upward, because it is parallel to the velocity vector, and since the skater is rotating counterclockwise, the velocity vector is pointing upward.

**E1. a.** 0.133 rev/s **b.** 0.84 rad/s **E3. a.** 50.3 rad **b.** 10.05 rad/s **E5. a.** 0.3 rad/s<sup>2</sup> **E7. a.** 2.4 rev/s **b.** 7.2 rev **E9.** 12.8 cm **E11. a.** 117 N·m **b.** -52 N·m **c.** 65 N·m **E13.** 33.2 N·m **E15.** 0.294 kg·m<sup>2</sup> **E17. a.** 0.56 kg·m<sup>2</sup> **b.** 8.4 kg·m<sup>2</sup>/s

**SP1. a.** 124 N·m **b.** 0.155 rad/s<sup>2</sup> **c.** 2.48 rad/s **d.** -0.0175 rad/s<sup>2</sup>, 141.7 s **SP3. a.** 435.6 kg·m<sup>2</sup>, 1535.6 kg·m<sup>2</sup> **b.** 1157.6 kg·m<sup>2</sup> **c.** 1.72 rad/s **d.** Yes, since the rotational velocity has changed. During the time the children are moving, friction between their feet and the merry-go-round produces the accelerating torque.

## Chapter 9

**Q3.** The pressure will be greater in the cylinder with the smaller-area piston. Pressure is force per unit area, so a smaller area yields a larger pressure for the same force.

**Q9.** Water could be used, but the barometer would have to be much larger than one using mercury because of the much smaller density of water. The water column would move greater distances for small changes in pressure, however, thus yielding a more sensitive measurement.

**Q15.** The pressure decreases. If the volume is slowly increased, heat can flow in to keep the temperature constant, giving a Boyle's Law situation. The pressure decreases as the volume increases.

**Q21.** The water level will increase by the amount of water the bird would displace if it were in the water.

**Q27.** No. The liquid with low viscosity will flow more rapidly. Viscosity is a frictional effect retarding the flow.

**E1.** 150 Pa **E3.** 1.50 lb/in.<sup>2</sup> **E5. a.** 270 kPa **b.** 81 kN

**E7.** 2125 Pa **E9.** 36.0 kPa **E11.** 250 kg/m<sup>3</sup>

**E13.**  $2.94 \times 10^3$  N **E15.** 1/3

**SP1. a.** 7.07 cm<sup>2</sup>, 452.4 cm<sup>2</sup> **b.** 64/1 **c.** 16,660 N **d.** 260.3 N

**SP3. a.**  $6.4 \times 10^{-5}$  m<sup>3</sup> **b.** 0.57 kg **c.** 5.62 N **d.** 0.627 N

**e.** 4.99 N **SP5. a.** 63.6 cm<sup>2</sup>, 21.2 cm<sup>2</sup> **b.** 4.79 m/s **c.** less than

## Chapter 10

**Q3.** Yes. Any system whose properties change with temperature could, in principle, be used as a thermometer.

**Q9.** Not if no other effect is involved, such as work being done on the system. Heat will flow from the hotter body to the colder body, resulting in an intermediate temperature for the two objects.

**Q15.** When the liquid is supercooled it hasn't yet frozen, but the temperature is below the freezing point. It needs to have a seed crystal in order to start the freezing process.

**Q21.** No. According to the first law, the internal energy will change equally whether a given amount of energy is added by performing work on the system or by heat added.

**Q27.** No. In a constant-volume process, there is no work done on (or by) the gas. Thus, all of the heat added to the gas will show up as an increase in internal energy, so the temperature will rise.

**Q33.** Conduction. Glass is a moderately good thermal conductor. We use glass vessels in the chemistry laboratory and glass in some coffeemakers.

**E1. a.** 71.6°F **b.** 295.2 K **E3. a.** 43.3°C **b.** 316.5 K

**E5. a.** 12°C **b.** 64.6°F **c.** 86°F **d.** 21.6°F **e.** The ratio of  $\Delta T(^{\circ}\text{F})/\Delta T(^{\circ}\text{C})$  is 9/5. Because the conversion between °C and °F involves a +32, when you subtract the two to get a difference this goes away ( $32 - 32 = 0$ ) and you are left with the ratio 9/5. **E7.** 7.74 kcal **E9.** 30°C **E11.** 1257 J

**E13. a.** decrease **b.** increase **c.** increases by 375 J

**E15.** 3000 K **E17. a.** 1676 J **b.** 1276 J **c.** 304.5 cal

**d.** increase

**SP1. a.** 106.2°F **b.** 59 K **c.** no **SP3. a.** 1.54 kcal

**b.** 11.2 kcal **c.** 3.78 kcal **d.** 16.53 kcal **e.** Melting the ice takes the most energy by far. **f.** No. Ice has a different heat capacity than water. So the heat needed to raise ice from

$-22^{\circ}\text{C}$  to  $0^{\circ}\text{C}$  cannot be calculated with the specific heat of water. **SP5. a.** 3976 J **b.** 948.9 cal **c.**  $1.6^{\circ}\text{C}$  **d.** Yes. The calorie and the Joule units are not equal. In the second case, the temperature would rise more.

## Chapter 11

**Q3.** The change in internal energy of a heat engine is assumed to be zero, because the engine operates in cycles, returning to its initial state at the end of each cycle. Because the engine is back in its initial state, there is no change in internal energy.

**Q9.** No, it is not possible. Such a heat engine would convert all heat input into work, which would violate the second law of thermodynamics.

**Q15.** The engine operating between 400 K and 300 K has the higher efficiency (.25 compared to .15 for the engine operating between  $400^{\circ}\text{C}$  and  $300^{\circ}\text{C}$ ).

**Q21.** Yes. This is what a refrigerator does. It doesn't violate the second law, because work is performed to accomplish it.

**Q27.** No, because it requires energy from some other source to freeze the substance. The increase of entropy of this source will always be greater than the loss of entropy of the cooled substance.

**Q33.** No. A perpetual motion machine, once started, would require no additional energy to keep going. The automobile engine requires continuous input of gasoline that is burned explosively to keep the engine running.

**E1.** 37% **E3. a.** 328 J **b.** 41% **E5. a.** 1800 J **b.** 38.9%

**E7.** 41.4% **E9.** 650 J **E11.** 300 W **E13.** No. The Carnot efficiency for this plant is 3.7%.

**SP1. a.** 22.8 MJ **b.** 97.2 MJ **c.** The work is used to overcome friction and air resistance. **d.** cold day, because the engine is able to get a greater compression of the intake air **SP3. a.** 5.1% **b.** 12.7 J **c.** 237.3 J **d.** 18.7 **SP5. a.** 35.5% **b.** 28.4% **c.** 125 000 kW·h **d.** 440,000 kW·h **e.** 259 barrels

## Chapter 12

**Q3.** The cloth gains electrons transferred from the glass rod. The glass rod becomes positively charged in the rubbing process by losing negatively charged electrons.

**Q9.** No. Glass is an insulator, so it does not allow charge to flow from the electroscope to your body. The electroscope will not discharge.

**Q15.** Not by themselves. They can be used in conjunction with a dry scrubber. The dry scrubber gets the pollutants attached to fine particles and the electrostatic precipitator can be used to remove the fine particles. Electrostatic precipitators are effective for removing small particles from the smoke produced in many industrial applications.

**Q21.** The force between the two charges will be quadrupled. The electrostatic force between the charges varies as the product of the two charges. Doubling each gives a four-fold increase.

**Q27.** No. The electric field lines that we can imagine emanating from the charge diverge with increasing distance, indicating a field that decreases in strength with distance.

**Q33.** Point B. Recall that a positive charge will move toward regions of lower electric potential, decreasing its potential energy while gaining kinetic energy, much like a falling rock. Since there is a negative charge at point C, a positive charge placed near point C would move toward point C (and if placed near point B would move away from the positive charge at point B), indicating that point C will have a lower electric potential.

**Q39.** When you comb your hair on a dry day, the friction between the hair and the comb cause electrons to be transferred from the comb to your hair. All your combed hairs now have the same charge, and thus the individual hairs repel one another. If you wet the comb, the water conducts the excess charges away from your hair, through the comb, and most likely onto your hand.

**E1.**  $7.0 \times 10^{14}$  electrons **E3.**  $+11 \mu\text{C}$  each **E5.** 8 N  
**E7. a.** 4.3 N **E9.** 180 N, down **E11.**  $3.53 \times 10^6$  N/C, due west **E13.** 5.4 J **E15.** 50,000 V

**SP1. a.**  $1.21 \times 10^7$  N **b.**  $2.16 \times 10^7$  N **c.**  $9.5 \times 10^7$  N, to the left **d.**  $1.58 \times 10^8$  N/C, to the left **e.**  $2.69 \times 10^7$  N, to the right **SP5. a.**  $-0.30$  J **b.** upward **c.** upward **d.**  $3.85 \times 10^4$  N/C

## Chapter 13

**Q3.** No. The current flowing around a single loop circuit is the same at every point in the loop. Unless charge is leaking out or building up somewhere, the current is conserved.

**Q9.** Diagram B will allow the lightbulb to light, because there is a closed circuit providing current from the battery through the bulb. Whether the switch is open or closed is immaterial here, because it is in parallel with another conductor. In diagram A, no potential difference is in the closed circuit because everything is connected to the positive terminal.

**Q15. a.** The current is the same in each, because it is a series circuit.

**b.** The voltage difference is greater across  $R_2$ . According to Ohm's Law,  $V = I \times R$ , so for the same current, the larger the resistance, the greater the potential difference.

**Q21.** The only one of these comments that is true is c.

**a.** The placement of the ammeter is incorrect. An ammeter should be placed in series in the circuit, just as a flow meter is placed in a fluid circuit. This placement will not correctly measure the current through the resistor. **b.** A lot of current will flow through the ammeter and may, in fact, damage it because of the incorrect placement. **c.** Yes, the ammeter will draw a large current from the battery, because it is a low-resistance device. Most of the current from the battery will probably flow through the ammeter and not the resistor (depending on the relative values).

**Q27.** No. A battery is based on a chemical reaction that creates a potential difference as a side effect. When the reaction is complete, no more potential difference is being generated.

**Q33.** The two types of metal have different rates of expansion when heated. Since the two metals are bonded together, the strip must bend to compensate for the greater length of one side.

**E1.** 4 A **E3.** 0.170 A **E5.** 220  $\Omega$  **E7. a.** 0.16 A  
**b.** 4.48 V across the 28-ohm resistor; 7.52 V across the 47-ohm resistor **E9. a.** 60 ohms **b.** 0.20 A **c.** 0.20 A  
**d.** Yes, current is the same, since the resistors are in series.  
**e.** 4 V **E11.** 3.83  $\Omega$  **E13.** 13.5 W  
**E15. a.** 0.682 A = 682 mA **b.** 161  $\Omega$  **E17.** 30 A

**SP1. a.** 10  $\Omega$  **b.** 273 mA **c.** 3.27 V **d.** 2.73 V **e.** 182 mAmps  
**f.** 0.891 W **g.** Greater, because all the current goes through the 12-ohm resistor, and only part of the current goes through the 15-ohm resistor. **SP3. a.** 57.1 mA  
**b.** 1.143 V **c.** 0.686 W **d.** charging **SP5. a.** 7.39 A (toaster), 10.44 A (waffle iron), 8.70 A (coffeemaker) **b.** Yes; the sum of the currents exceeds the rating for the fuse, so it will blow. **c.** 11  $\Omega$

## Chapter 14

**Q3.** The two forces obey similar rules for attraction and repulsion (like poles or charges repel; unlike poles or charges attract). Also, both forces decrease proportionally to the inverse square of the distance as the distance increases.

**Q9.** The needle should not deflect much, because the magnetic field of the wire is directed northward above the east-west wire and the compass needle is already pointing approximately in that direction.

**Q15.** There is no magnetic force on a charge when there is no component of velocity perpendicular to the magnetic field.

**Q21.** Yes. The forces combine to rotate the loop until its plane is perpendicular to the field, at which time the net torque is zero.

**Q27.** No. Magnetic flux is the product of magnetic field times an area perpendicular to the field direction. If one draws magnetic field lines such that the field strength is the number of lines crossing unit area, then the flux across a surface is simply the number of lines.

**Q33.** Yes. Although the magnetic field is constant, because the coil is rotating, the flux through the coil is continuously changing. Flux is the product of the area times the component of the field perpendicular to it. It is easier to visualize in terms of lines of force. The field lines are constant, and as the generator coil rotates, the number of lines crossing the coil goes from zero to a maximum and back.

**E1.** 2 N **E3.** It is one-half the original value. **E5.** 48 C  
**E7.** 0.42 N **E9.** 1.8 T·m<sup>2</sup> **E11.** 18 V **E13. a.** step-up, because the number of windings on the secondary coil is greater (see example box 14.3) **b.** 600 V **E15.** 43 turns

**SP1. a.**  $4.8 \times 10^{-4}$  N/m **b.** repulsive **c.**  $1.44 \times 10^{-4}$  N  
**d.**  $4 \times 10^{-5}$  T **e.** into the plane of the page **SP3. a.** 0.0032 m<sup>2</sup>  
**b.** 0.1120 T·m<sup>2</sup> **c.** zero **d.** 0.25 s **e.** 0.448 V



## Chapter 15

**Q3.** The magnet is stationary, but the buoy and a coil of wire move in response to the wave motion, generating a voltage as described by Faraday's law.

**Q9.** Yes, a slinky can be used as a heavy string to show transverse wave motion. With some tension in the spring, shaking one end back and forth at right angles to the spring can very effectively demonstrate transverse wave motion.

**Q15.** Increasing the tension in a rope will increase the wavelength of transverse waves for a constant frequency. Wavelength is proportional to wave velocity at constant frequency, and wave velocity is proportional to the square root of the tension.

**Q21.** No. The distance between adjacent antinodes of a standing wave is equal to one-half the wavelength of the interfering waves.

**Q27.** Increasing the temperature of air in an organ pipe will increase the frequency of standing waves. Assuming the pipes retain the same length, the wavelength of standing waves remains constant. Thus, increasing the wave velocity by increasing the temperature will increase the frequency.

**Q33.** The portion of the string that is plucked more closely corresponds to the position of an antinode of the second harmonic.

**E1.** 0.38 Hz **E3.** 0.25 m **E5. a.** 5.0 Hz **b.** 2.3 m  
**E7. a.** 1.5 m **b.** 86.7 Hz **E9.** 77.3 cm **E11. a.** 2.4 m  
**b.** 141.7 Hz **E13.** 261 Hz **E15.** 69 Hz **E17.**  $\Delta f = 90$  Hz;  
 360 Hz is the fourth harmonic of the beat frequency; 450 Hz is the fifth harmonic of the beat frequency.

**SP1. a.** 0.267 kg/m **b.** 13.5 m/s **c.** 3.0 m **d.** 4 cycles  
**e.** 0.89 s (four periods) **SP3. b.** 120 cm **c.** 283.3 Hz  
**d.** 15 Hz increase **e.** 60 cm, 566.6 Hz **SP5. a.** 396 Hz  
**b.** 352 Hz **c.** 330 Hz **d.** 495 Hz **e.** 297 Hz **f.** 440 Hz

## Chapter 16

**Q3.** Yes. Electric and magnetic fields exist in otherwise empty space, so an electromagnetic wave consisting of changing electric and magnetic fields can propagate through a vacuum. Unlike mechanical waves, it does not require a medium.

**Q9.** The surface would appear purple or magenta depending on the amounts of blue and red light reflected.

**Q15.** They will be out of phase by  $180^\circ$ .

**Q21.** The antireflective coatings are most effective for wavelengths in the middle of the visible spectrum. At the red or blue end of the spectrum, the conditions for destructive interference are not met, so some of this light is reflected, giving the lenses a purplish tinge.

**Q27.** Yes. This is a transverse wave and can be polarized.

**E1.** 2.5 GHz ( $2.5 \times 10^9$  Hz) **E3.**  $6.38 \times 10^{14}$  Hz  
**E5.** 3.5 mm **E7.** 6.8 cm **E9. a.**  $\frac{1}{2}$  wavelength  
**b.** destructive **E11.** 0.109 mm **E13. a.** 9.34 cm **b.** 18.68 cm

**SP1. a.**  $7.9 \times 10^{14}$  Hz,  $4.0 \times 10^{14}$  Hz **b.**  $2 \times 10^8$  m/s  
**c.** 253 nm, 500 nm **SP3. a.** 150 nm **b.** 300 nm **c.** No, lines are too closely spaced to be apparent as separate lines.

## Chapter 17

**Q3.** The light is reflected from the mirror so that the light rays appear to diverge from a point behind the mirror. The virtual image we see is located at this point.

**Q9.** The light bends toward the surface normal, because the index of refraction of the glass (the second medium) is greater than that of water. The light waves travel more slowly in the glass than in water.

**Q15.** Refraction is responsible for the rainbow colors. Although both reflection and refraction occur in the raindrops, dispersion (variation of index of refraction with wavelength) is important only for refraction, not for reflection.

**Q21.** No. Light rays converging toward the far-side focal point of a negative lens emerge from the lens parallel to one another. They neither diverge nor converge.

**Q27.** The images lie a short distance behind the convex sideview mirror. Unlike images formed by a plane mirror, however, these images are greatly reduced in size compared to the actual size of the objects. For objects of known size, our brains make distance judgments based partly upon the small size of the images, which makes the images appear to be farther away.

**Q33.** No. Because the object for a telescope is distant, the real image produced by the objective lens is reduced in size. The eyepiece does magnify the reduced image. The point of the telescope is that the real image, though smaller, is much closer to the eye, so that there is a gain in terms of the size of the image on the retina using the instrument.

**E1.** 1.7 m tall, 5 m away **E3.** 22.6 cm **E5. a.** 9 cm  
**b.** real, inverted **c.** See figure 17.16. **E7.** 4.43 cm  
**E9. a.**  $-6$  cm **b.** 3X **E11. a.**  $+30$  cm **b.** real, inverted  
**c.** See figure 17.22. **E13. a.**  $-51.7$  cm **b.** 28 cm  
**E15. a.** 1.85 m **b.**  $-0.23$  **E17.** 45 cm

**SP1. a.** 6.02 cm **b.** 6.32 cm **c.** 3.76 cm **SP3. a.** 24 cm  
**b.**  $-2.0$  **c.** See figure 17.16. **d.** 18 cm,  $-2$  **e.** 4X  
**SP5. a.** 3.6 cm **b.**  $-3X$  **c.**  $-7.2$  cm **d.** 4X **e.**  $-12X$

## Chapter 18

**Q3.** When a substance containing carbon compounds is burned, oxygen gas from the air reacts with the compounds to produce carbon dioxide (a gas), as well as solid ash and often water vapor, which is also a gas. The gases can be difficult to capture and weigh.

**Q9.** No. Hydrogen and oxygen can combine to form water,  $H_2O$ , and hydrogen peroxide,  $H_2O_2$ . For a particular reaction, the same relative numbers of hydrogen and oxygen will combine.

**Q15.** Yes. X-rays are produced when charged particles strike a target, which is the case for electrons in a television tube.

**Q21.** Because the nucleus of the gold atom is so small compared to the size of the atom as a whole, a beam of alpha particles will contain only a few that will pass near enough to the nucleus to be appreciably deviated by the Coulomb

force. Rutherford found that atoms consist almost entirely of empty space.

**Q27.** No. In order to explain the observed blackbody radiation, Planck had to assume that energy must be emitted or absorbed by the walls of the blackbody in discrete amounts depending on the frequency.

**Q33.** According to the uncertainty principle, it is not possible to precisely and simultaneously define the motion and position of a body. The simple Bohr picture of precisely defined orbits cannot be strictly true.

**E1.** 32:114 = 0.28/1 **E3.** 28 **E5.** 1835 **E7.**  $5 \times 10^{16}$  Hz  
**E9.** 1005 nm. No, it is in the infrared region.

**E11.** a.  $4.62 \times 10^{14}$  Hz **b.** 650 nm **c.** red **E13.** a.  $6.9 \times 10^{14}$  Hz **b.** 435 nm

**SP1.** a. upward **b.** 12,500 N/C **c.**  $2.0 \times 10^{-15}$  N

**d.**  $2.2 \times 10^{15}$  m/s<sup>2</sup>, upward **e.** an upward-bending trajectory

**SP3.** a. 13.6 eV **b.** 3.4 eV **c.** 91.3 nm

## Chapter 19

**Q3.** Yes. Different isotopes of the same element have different masses, because the number of neutrons in the nucleus is different. The chemical properties that define the element are determined by the atomic number, not the neutron number.

**Q9.** The atomic number of the daughter element is larger than that of the original isotope for normal beta decay in which a negatively charged electron is emitted. One of the neutrons in the nucleus changes to a proton, increasing the atomic number by one. If a positron is emitted, the atomic number decreases by one.

**Q15.** No. The rate of decay of a radioactive substance depends on both the number of radioactive nuclei present and the particular element involved.

**Q21.** No.  $U^{235}$  is the isotope most likely to undergo fission. Some  $U^{238}$  can undergo fission when a neutron is captured, but a competing process involves emission of radiation after capturing a neutron.

**Q27.** No. When a nuclear reactor is subcritical, a fission reaction may or may not result in a new fission reaction. Thus, there may be fewer reactions at any given moment, effectively slowing down the reactions overall.

**Q33.** The nuclear reactors at Hanford were used to produce plutonium for use in nuclear bombs in World War II.

**E1.** 22 **E3.** titanium,  ${}_{22}\text{Ti}^{49}$  **E5.**  ${}_{84}\text{Po}^{218}$  **E7.**  ${}_{7}\text{N}^{15}$   
**E9.** 7 days **E11.**  ${}_{36}\text{Kr}^{90}$

**SP1.** a. 6,6; 7,7; 8,8 **b.** 1.0/1 **c.** 61, 47; 64, 48; 66, 49

**d.** 1.30, 1.33, 1.35; ave = 1.33/1 **e.** 142, 90; 140, 91;

146, 92; 1.58, 1.54, 1.59; ave = 1.57/1 **SP3.** a. 0.003 51 u

**b.**  $5.25 \times 10^{-13}$  J **c.** yes

## Chapter 20

**Q3.** The velocity of the plane relative to the ground will be larger than the velocity of the plane relative to the air. Because the air is moving in the same direction as the plane, the air velocity adds directly to the velocity of the plane relative to the air.

**Q9.** Yes. Light waves can travel through a vacuum, so the ether was assumed to exist in a vacuum.

**Q15.** Observer A measures the longer time. Observer B measures the proper time for the chess move, because it takes place at a single point in his frame of reference. Observer A measures a dilated (longer) time.

**Q21.** The relativistic expression for momentum is valid at any speed. However, the correction term  $\gamma$  would be very close to 1.0 at low speeds, so the classical and relativistic expressions are essentially the same at ordinary speeds.

**Q27.** No. According to Einstein's principle of equivalence, it is impossible to distinguish an acceleration of your reference frame from gravitational effects.

**E1.** 7 m/s, upstream **E3.** 1.3 m/s **E5.**  $c = 3 \times 10^8$  m/s

**E7.** 5.0 min **E9.** 66.79 m **E11.**  $1.39 \times 10^{12}$  kg·m/s

**SP1.** b. 7.62 m/s **c.** 4 s **d.** 12 m **e.** 30.5 m **SP3.** b. 92.5 yr

**c.** 9.25 yr **d.** 9.25 light-years **e.** 83.21 yr

## Chapter 21

**Q3.** No. Quarks are constituents of mesons and baryons, the latter of which include protons and neutrons. Electrons are leptons and, as far as we know, leptons have no subparticles or more fundamental constituents.

**Q9.** Yes. Our sun is part of the Milky Way galaxy, which contains an enormous number of other stars. Part of the Milky Way galaxy is visible on a clear night as a cloud-like band across the sky.

**Q15.** The Big Bang is the process from which the present expansion of the universe began. The stars, and matter as we know it, did not exist at the beginning—matter and energy were not separate forms. (Collisions of photons can produce subatomic particles, however—in other words, matter!)

**Q21.** The transistor is a three-terminal device—base, emitter, and collector—and can serve as an amplifier of electrical signals, because a small change in current between the base and the emitter can control a large change in the current between the collector and the emitter.

**Q27.** They are viewed from a different angle and, so, the front corner of the cube is displaced differently relative to the back corner of the cube in the two views.

**E1.** 366.7 seconds = 6.1 minutes

**SP1.** a.  $3.15 \times 10^7$  s **b.**  $9.45 \times 10^{15}$  m **c.**  $4.02 \times 10^{16}$  m

**d.** 42.5 yr



# Appendix E

## Conversion Factors and Periodic Table of the Elements

### Conversion Factors

#### LENGTH

1 in = 2.54 cm  
1 cm = 0.394 in  
1 ft = 30.5 cm  
1 m = 39.4 in = 3.281 ft  
1 km = 0.621 mi  
1 mi = 5280 ft = 1.609 km  
1 light-year =  $9.461 \times 10^{15}$  m

#### MASS AND WEIGHT

1 lb = 0.4536 kg (where  $g = 9.80$  m/sec<sup>2</sup>)  
1 kg = 2.205 lb (where  $g = 9.80$  m/sec<sup>2</sup>)  
1 atomic mass unit (u) =  $1.66061 \times 10^{-27}$  kg

#### VOLUME

1 liter = 1.057 quarts = 0.264172 gallon  
1 in<sup>3</sup> = 16.4 cm<sup>3</sup>  
1 gallon = 3.785412 liters  
1 ft<sup>3</sup> =  $2.832 \times 10^{-2}$  m<sup>3</sup>

#### ENERGY AND POWER

1 cal = 4.186 J  
1 J = 0.239 cal  
1 kWhr =  $3.60 \times 10^6$  J = 860 kcal  
1 hp = 746 W  
1 J =  $6.24 \times 10^{18}$  eV  
1 eV =  $1.6022 \times 10^{-19}$  J

#### TEMPERATURE

Absolute zero (0 K) =  $-273.15^\circ\text{C}$

#### SPEED

1 km/hr = 0.278 m/sec = 0.621 MPH  
1 m/sec = 3.60 km/hr = 2.237 MPH = 3.281 ft/sec  
1 MPH = 1.609 km/hr = 0.447 m/sec = 1.47 ft/sec  
1 ft/sec = 0.305 m/sec = 0.682 MPH

#### FORCE

1 N = 0.2248 lb  
1 lb = 4.448 N

#### PRESSURE

1 atm = 1.013 bar =  $1.013 \times 10^5$  N/m<sup>2</sup> = 14.7 lb/in<sup>2</sup>  
1 lb/in<sup>2</sup> =  $6.90 \times 10^3$  N/m<sup>2</sup>  
1 Pa = 1 N/m<sup>2</sup>

#### ANGLE

1 rad =  $57.30^\circ$   
1° = 0.01745 rad  
1 rev =  $360^\circ = 2\pi$  rad

**METRIC PREFIXES**

Prefix	Symbol	Meaning
Giga-	G	1 000 000 000 times the unit
Mega-	M	1 000 000 times the unit
Kilo-	k	1 000 times the unit
Hecto-	h	100 times the unit
Deka-	da	10 times the unit
Base Unit		
Deci-	d	0.1 of the unit
Centi-	c	0.01 of the unit
Milli-	m	0.001 of the unit
Micro-	$\mu$	0.000 001 of the unit
Nano-	n	0.000 000 001 of the unit

**MATHEMATICAL CONSTANTS AND FORMULAS**

Pi	3.1416
Area of circle	$\pi r^2$
Circumference of circle	$2\pi r$
Area of sphere	$4\pi r^2$
Volume of sphere	$4/3 \pi r^3$

**PHYSICAL CONSTANTS AND DATA**

Quantity	Approximate Value
Acceleration of gravity (near the Earth's surface)	$g = 9.80 \text{ m/sec}^2$
Gravitational law constant	$G = 6.67 \times 10^{-11} \text{ N} \cdot \text{m}^2/\text{kg}^2$
Earth radius (mean)	$6.38 \times 10^6 \text{ m}$
Earth mass	$5.98 \times 10^{24} \text{ kg}$
Earth-sun distance (mean)	$1.50 \times 10^{11} \text{ m}$
Earth-moon distance (mean)	$3.84 \times 10^8 \text{ m}$
Fundamental charge	$e = 1.60 \times 10^{-19} \text{ C}$
Coulomb law constant	$k = 9.00 \times 10^9 \text{ N} \cdot \text{m}^2/\text{C}^2$
Electron rest mass	$9.11 \times 10^{-31} \text{ kg}$
Proton rest mass	$1.6726 \times 10^{-27} \text{ kg}$
Neutron rest mass	$1.6750 \times 10^{-27} \text{ kg}$
Bohr radius	$5.29 \times 10^{-11} \text{ m}$
Avogadro's number	$6.02 \times 10^{23}/\text{mole}$
Boltzmann's constant	$1.38 \times 10^{-23} \text{ J/K}$
Planck's constant	$6.626 \times 10^{-34} \text{ J} \cdot \text{s}$
Speed of light (vacuum)	$3.00 \times 10^8 \text{ m/s}$

# Periodic Table of the Elements

		Atomic number		Atomic mass													
1 1A	2 2A	3 3B	4 4B	5 5B	6 6B	7 7B	8 8B	9	10	11 1B	12 2B	13 3A	14 4A	15 5A	16 6A	17 7A	18 8A
1 <b>H</b> 1.008	2 <b>He</b> 4.003	3 <b>Li</b> 6.941	4 <b>Be</b> 9.012	5 <b>B</b> 10.81	6 <b>C</b> 12.01	7 <b>N</b> 14.01	8 <b>O</b> 16.00	9 <b>F</b> 19.00	10 <b>Ne</b> 20.18	11 <b>Na</b> 22.99	12 <b>Mg</b> 24.31	13 <b>Al</b> 26.98	14 <b>Si</b> 28.09	15 <b>P</b> 30.97	16 <b>S</b> 32.07	17 <b>Cl</b> 35.45	18 <b>Ar</b> 39.95
19 <b>K</b> 39.10	20 <b>Ca</b> 40.08	21 <b>Sc</b> 44.96	22 <b>Ti</b> 47.88	23 <b>V</b> 50.94	24 <b>Cr</b> 52.00	25 <b>Mn</b> 54.94	26 <b>Fe</b> 55.85	27 <b>Co</b> 58.93	28 <b>Ni</b> 58.69	29 <b>Cu</b> 63.55	30 <b>Zn</b> 65.39	31 <b>Ga</b> 69.72	32 <b>Ge</b> 72.59	33 <b>As</b> 74.92	34 <b>Se</b> 78.96	35 <b>Br</b> 79.90	36 <b>Kr</b> 83.80
37 <b>Rb</b> 85.47	38 <b>Sr</b> 87.62	39 <b>Y</b> 88.91	40 <b>Zr</b> 91.22	41 <b>Nb</b> 92.91	42 <b>Mo</b> 95.94	43 <b>Tc</b> (98)	44 <b>Ru</b> 101.1	45 <b>Rh</b> 102.9	46 <b>Pd</b> 106.4	47 <b>Ag</b> 107.9	48 <b>Cd</b> 112.4	49 <b>In</b> 114.8	50 <b>Sn</b> 118.7	51 <b>Sb</b> 121.8	52 <b>Te</b> 127.6	53 <b>I</b> 126.9	54 <b>Xe</b> 131.3
55 <b>Cs</b> 132.9	56 <b>Ba</b> 137.3	57 <b>La</b> 138.9	58 <b>Ce</b> 140.1	59 <b>Pr</b> 140.9	60 <b>Nd</b> 144.2	61 <b>Pm</b> (147)	62 <b>Sm</b> 150.4	63 <b>Eu</b> 152.0	64 <b>Gd</b> 157.3	65 <b>Tb</b> 158.9	66 <b>Dy</b> 162.5	67 <b>Ho</b> 164.9	68 <b>Er</b> 167.3	69 <b>Tm</b> 168.9	70 <b>Yb</b> 173.0	71 <b>Lu</b> 175.0	72 <b>Hf</b> 178.5
87 <b>Fr</b> (223)	88 <b>Ra</b> (226)	89 <b>Ac</b> (227)	90 <b>Th</b> 232.0	91 <b>Pa</b> (231)	92 <b>U</b> 238.0	93 <b>Np</b> (237)	94 <b>Pu</b> (242)	95 <b>Am</b> (243)	96 <b>Cm</b> (247)	97 <b>Bk</b> (247)	98 <b>Cf</b> (249)	99 <b>Es</b> (254)	100 <b>Fm</b> (253)	101 <b>Md</b> (256)	102 <b>No</b> (254)	103 <b>Lr</b> (257)	104 <b>Rf</b> (257)
101 <b>Db</b> (260)	102 <b>Sg</b> (263)	103 <b>Bh</b> (262)	104 <b>Hs</b> (265)	105 <b>Mt</b> (266)	106 <b>Ds</b> (269)	107 <b>Rg</b> (272)	108 <b>Cn</b> (277)	109 <b>Nh</b> (284)	110 <b>Fl</b> (289)	111 <b>Mc</b> (289)	112 <b>Lv</b> (293)	113 <b>Ts</b> (294)	114 <b>Og</b> (294)	115 <b>Uu</b> (294)	116 <b>Uub</b> (294)	117 <b>Uut</b> (294)	118 <b>Uuq</b> (294)
105 <b>Utp</b> (260)	106 <b>Utg</b> (263)	107 <b>Utq</b> (262)	108 <b>Uth</b> (265)	109 <b>Utl</b> (266)	110 <b>Utm</b> (269)	111 <b>Utn</b> (272)	112 <b>Uto</b> (277)	113 <b>Utu</b> (284)	114 <b>Utu</b> (289)	115 <b>Utu</b> (289)	116 <b>Utu</b> (293)	117 <b>Utu</b> (294)	118 <b>Utu</b> (294)	119 <b>Utu</b> (294)	120 <b>Utu</b> (294)	121 <b>Utu</b> (294)	122 <b>Utu</b> (294)
121 <b>Uup</b> (294)	122 <b>Uug</b> (294)	123 <b>Uuq</b> (294)	124 <b>Uur</b> (294)	125 <b>Uus</b> (294)	126 <b>Uut</b> (294)	127 <b>Uuu</b> (294)	128 <b>Uuu</b> (294)	129 <b>Uuu</b> (294)	130 <b>Uuu</b> (294)	131 <b>Uuu</b> (294)	132 <b>Uuu</b> (294)	133 <b>Uuu</b> (294)	134 <b>Uuu</b> (294)	135 <b>Uuu</b> (294)	136 <b>Uuu</b> (294)	137 <b>Uuu</b> (294)	138 <b>Uuu</b> (294)

Metals

Metalloids\*

Nonmetals

\*Metalloids (which include semiconductors) have properties intermediate between metals and nonmetals.



# Glossary

**Absolute temperature** Temperature given in the Kelvin scale, which sets 0 K at absolute zero. Room temperature of 72°F or 22°C is about 295 K.

**Absolute zero** The lowest possible temperature, 0 K (kelvin) or  $-273^{\circ}\text{C}$ ; the point where a gas would have no pressure or molecular motion.

**Acceleration** The rate of change of velocity.

**Acceleration due to gravity** The uniform acceleration of an object in a gravitational field,  $g = 9.8 \text{ m/s}^2$ , near the Earth's surface (also called the *gravitational acceleration*).

**Action/reaction principle** For every action (force acting on one body), there is an equal but opposite reaction (force acting on another body), as described in Newton's third law of motion.

**Additive color mixing** The production of different colors by combining light of the three primary colors blue, green, and red.

**Adiabatic** An adjective that describes a thermodynamic change or process without gain or loss of heat.

**Air resistance** The frictional effects of the air or atmosphere on the motion of objects—especially noticeable on objects with large surface areas compared to their masses, like leaves and feathers.

**Alternating current** Electric current that continually reverses its direction. Current in use in North America is set at 60 Hz (60 back-and-forth cycles a second) and has an *effective* voltage of 115 V.

**Amplitude** The maximum swing from the point of equilibrium—for example, in the movement of a pendulum.

**Angular momentum** The rotational equivalent of linear momentum, found by multiplying the rotational inertia  $I$  by the rotational velocity  $\omega$ , or  $\mathbf{L} = I\omega$ ; also called *rotational momentum*. Angular momentum helps to explain the orbits of planets, twirling ice skaters, and the spin of subatomic particles.

**Antinode** The point, or points, in a standing wave with the greatest amplitude.

**Antiparticle** An elementary particle with some properties, such as electric charge, opposite those of the corresponding particle. The antiparticle of an electron, for example, is a positron. When these two particles interact, they annihilate each other.

**Archimedes' principle** The buoyant force acting on an object fully or partly submerged in a fluid equals the weight of the fluid displaced by the object.

**Atmospheric pressure** The pressure of the layer of air that surrounds the Earth. At sea level, the atmospheric pressure is 14.7 pounds per square inch but decreases with altitude.

**Atom** From the Greek word for *undivided*, the smallest particle of an element, now known to be made up of a nucleus surrounded by one or more electrons.

**Atomic mass** The average mass of an atom of an element, a distinguishing characteristic of an element.

**Atomic number** The number of protons in an element's nucleus, which determines its place in the periodic table. Oxygen's atomic number is 8, krypton's is 36, and gold's is 79.

**Atomic physics** The subfield of physics that studies the structure and behavior of atoms.

**Atomic spectrum** The wavelengths of light emitted by a substance when heated. In the visible spectrum of light, each element produces a distinctive color display.

**Average acceleration** Change in velocity divided by the time required to produce that change,  $\mathbf{a} = \Delta\mathbf{v}/t$ .

**Average speed** Distance traveled divided by the time traveled (in symbols,  $s = dt$ ), the *rate* at which distance is covered.

**Baryon** The heaviest of subatomic particles—for example, neutrons and protons.

**Beat** A regular variation in amplitude caused by the interference of two waves of different frequency.

**Bernoulli's principle** Pressure is lower where fluid speed is higher: The sum of the pressure plus the kinetic energy per unit of volume of a flowing fluid is constant.

**Big Bang** The theoretical beginning of the universe 10 to 20 billion years ago from an expansion, which continues, of an extremely dense volume.

**Birefringence** A process (also called *double refraction*) in which light of different polarizations travels with different speeds in different directions within a material.

**Black hole** A very massive, collapsed star with an extremely strong gravitational field that lets light in but not out, which makes it a perfect absorber of light.

**Blackbody** Any body that absorbs all the radiation that falls on it, appearing perfectly black. Also, an instrument with a hole or cavity (dark at room temperature) that, when heated, emits a spectrum based on temperature and not on the composition of the material.

**Boyle's law** The volume of a gas at constant temperature is inversely proportional to the pressure on it—doubling the pressure on a gas will halve its volume. In symbols,  $PV = \text{constant}$ , where  $P$  is pressure on a gas and  $V$  is its volume.

**Buoyant force** An upward force that lifts objects toward the surface of water or other fluid.

**Capacitor** A device for storing electric charge.

**Carnot efficiency** The efficiency of an ideal heat engine, or the maximum efficiency possible of a heat engine operating between two specified temperatures.

**Carnot engine** An ideal reversible heat engine using the Carnot cycle. Any heat engine with an irreversible step in its cycle will be less efficient. A Carnot engine is not physically possible.



- Cathode rays** Radiation emitted by a cathode in an evacuated tube, since discovered to be electrons.
- Center of gravity** The point on an object about which its weight exerts no net torque and the object will balance.
- Centripetal acceleration** The rate of change in velocity of an object on a circular or curved path. For uniform circular motion, centripetal acceleration is always perpendicular to the velocity vector and directed toward the center of the curve.
- Centripetal force** Any force or combination of forces that produces a centripetal acceleration.
- Chain reaction** A fission reaction that by initiating several more reactions, becomes self-sustaining.
- Change of phase** The process of a substance going from one physical state—solid, liquid, or gas—to another; also called *phase change*.
- Circuit** A closed or complete path for an electric current.
- Classical physics** The four branches of physics—mechanics, thermodynamics, electricity and magnetism, and optics—that were already well developed by the beginning of the twentieth century.
- Combustion** Rapid combining of oxygen with a fuel; burning.
- Concave mirror** A mirror in which light is reflected from the inside of a curved surface.
- Condensed-matter physics** The subfield of physics that studies the properties of matter in the solid and liquid states.
- Conduction** The ability of heat to flow through a material when objects at different temperatures are placed in contact.
- Conductivity** The ability of a material to carry electric current.
- Conductor** A material that readily allows charge to flow.
- Conservation laws** Principles of physics that show how, under certain conditions, a specified quantity in a system does not change regardless of actions that may take place. For example, in *conservation of angular momentum*, the total angular momentum of a system remains constant as long as the total torque on the system is zero. *Conservation of energy* means that the amount of mechanical energy of a system remains constant through physical changes or processes (if no work is done on the system). *Conservation of momentum* shows that the momentum of a system remains constant (changes of different parts of the system cancel) if no net external force acts on it.
- Conservation of angular momentum** If the net torque acting on a system is zero, the total angular momentum of the system is conserved.
- Conservation of energy** If the amount of mechanical energy of a system remains constant through physical changes or processes (when no work is done on the system), then the energy is conserved.
- Conservation of momentum** If the momentum of a system remains constant (changes of different parts of the system cancel) when no net external force acts on the system, then the momentum is conserved.
- Conservative forces** Forces such as gravity or the elastic forces that allow complete recovery of energy when work is done against them.
- Control rods** Rods that can be inserted or removed from the core of a nuclear reactor to maintain a desired rate of reaction. The rods are made of a neutron-absorbing substance, boron being the most common.
- Convection** The transfer of heat by the motion or circulation of a fluid (gas or liquid) that contains thermal energy.
- Convex mirror** A mirror in which light is reflected from the outside of a curved surface.
- Coolant** The fluid (usually water) used to remove heat from a nuclear reactor or other heat engines.
- Cosmology** The study of the structure and origins of the universe.
- Coulomb's law** Electrostatic force is proportional to the size of each of the charges and inversely proportional to the square of the distance between two charges.
- Critical mass** A mass of fuel just large enough to produce a self-sustaining chain reaction.
- Critical temperature** In electric resistance, the temperature below which a substance becomes a superconductor of electricity.
- Dalton's law of definite proportions** Dalton's observation that the ratio of the masses of certain elements needed in chemical reactions did not vary, which helped to clarify the relationships of the masses of the atoms of elements.
- Density** Mass per unit of volume.
- Diffraction** Interference of light and other waves coming through different parts of the same slit or opening.
- Diffraction grating** An instrument made of closely spaced parallel lines on a surface (glass or metal) used for diffracting light to produce spectra and other optical effects.
- Diode** An electronic device that allows electric current to flow in one direction only.
- Direct current** Electric current that flows in a single direction.
- Dispersion** The variation of the index of refraction of a transparent substance with wavelength. In a prism, this results in separation of light into its wavelengths, producing color displays.
- Doping** The intentional introduction of impurities into an intrinsic semiconductor to modulate its electrical properties.
- Doppler effect** A change in the detected frequency of a wave because of movement by either the source or the observer.
- Eclipse** A planet's passage into another planet's shadow. In a *lunar* eclipse, the moon passes into the Earth's shadow. In a *solar* eclipse, the Earth passes into the shadow of the moon.
- Efficiency** The ratio of the work an engine produces to the input of heat energy, usually given as a percentage.
- Elastic collision** A collision in which no energy is lost. The objects bounce off each other.
- Elastic force** The force exerted by objects that can be deformed or stretched, such as a bowstring or a spring.
- Elastic potential energy** Potential energy in a system that depends on the displacement from equilibrium of an elastic object, like a spring.
- Electric charge** The electromagnetic property of an object that produces the electrostatic force. A transfer of electrons to or from an object makes it electrically positive or negative.
- Electric current** The rate of flow of electric charge.
- Electric dipole** Two equal-magnitude electric charges opposite in sign separated by a small distance.
- Electric field** The electric force per unit of positive charge exerted on a charge if it were placed at that point. It is a property of space surrounding a distribution of electric charges.
- Electric potential** The potential energy per amount of positive electric charge; voltage.
- Electricity and magnetism** The subfield of physics that studies electric and magnetic forces and electric current.
- Electromagnet** A current-carrying coil of wire with an iron core whose magnetic field is produced by electric current.
- Electromagnetic induction** The production of electric current by a changing magnetic flux.
- Electromagnetic spectrum** The array of electromagnetic waves of different

- wavelengths. At the longer-wavelength end of the spectrum are radio waves and microwaves. Visible light begins with longer red waves and progresses to violet. Beyond violet (ultraviolet) are X-rays and gamma rays.
- Electromagnetic waves** Waves made up of changing electric and magnetic fields.
- Electromotive force** Potential energy per unit of charge produced by a battery or other source of electric energy. The name is misleading, because it is a potential difference (or voltage), *not* a force.
- Electron** An extremely small, negatively charged particle presents in all atoms.
- Electrostatic force** The force exerted by one stationary charge on another independently of their motion. The electrostatic force holds atoms together and binds one atom to another in liquids and solids.
- Electroweak force** The electromagnetic force and the weak nuclear force unified into a single fundamental force.
- Element** A basic chemical substance that consists of atoms of one kind.
- Ellipse** An oval curve with two foci—the shape of the orbits of the planets. A circle is a special case of an ellipse with both foci at one point.
- Empirical law** A rule or generalization derived from experience, which in the sciences would come from, and be confirmed by, experiments and observations.
- Enrichment** Increasing the proportion of the more reactive isotope of a nuclear fuel by separating the isotopes.
- Entropy** The measure of the disorder or randomness of a system.
- Epicyle** An imaginary circle made by the planets on their main orbits, used in the obsolete Ptolemaic model to explain planetary motions.
- Equally tempered** A type of tuning system based on equal ratios for all half steps in a musical scale.
- Equation of state** An equation that gives the thermodynamic relation between pressure, volume, and temperature for a specific kind of system.
- Exponential decay** Decay at a decreasing rate over time, which is graphed as an exponential curve.
- Faraday's law** Induced voltage in a coil equals the rate of change of the magnetic flux through the coil,  $\varepsilon = \Delta\phi/t$ .
- Field lines** Graphical illustrations of electric and magnetic fields.
- First law of thermodynamics** The change in internal energy of a system equals the net amount of heat and work transferred into the system (conservation of energy).
- Focal length** The distance from the center of a lens or mirror to the focal point or points.
- Focal point** The point where a lens focuses, or concentrates, parallel beams of light.
- Force** The quantity that describes the mechanical interaction of two objects, causing the objects to accelerate as described in Newton's laws of motion.
- Frame of reference** A standpoint or orientation from which we make measurements and observations of motion and to which we refer them. An *inertial* frame of reference does not accelerate in relation to other inertial frames.
- Free fall** The motion of a falling object affected only by acceleration due to gravity.
- Free-body diagram** A drawing commonly used in physics that identifies the interactions and directions of forces on objects.
- Frequency** The number of pulses, repetitions, or cycles per unit of time.
- Frictional forces** Forces that resist an object's movement.
- Fulcrum** A pivot point or support for a lever.
- Galaxy** A rotating assemblage of stars, usually shaped like an ellipse or a disk with spiral arms. Our solar system is in the Orion arm of the Milky Way galaxy.
- General theory of relativity** Einstein's generalization of his special theory of relativity to encompass accelerated frames of reference. Relying on the principle of equivalence, its basic postulate is that an acceleration of a frame of reference cannot be distinguished from the presence of gravity.
- Generator** A device that converts the mechanical energy of a rotating coil to electric energy by electromagnetic induction.
- Geometric optics** A branch of optics that describes the behavior of light schematically using straight-line rays and the laws of reflection and refraction.
- Global warming** The increase in the average surface temperature of our Earth.
- Grand unified theories** Theories that seek to explain all of the elementary particles and the forces between them. One result of these theories is the uniting of the electroweak and strong forces into a single fundamental force.
- Gravitational potential energy** Stored energy linked with the position of an object in a gravitational field rather than with the object's motion.
- Gravitational red shift** A lengthening in the wavelength of light toward the red end of the spectrum as photons move through a strong gravitational field.
- Greenhouse effect** The trapping of radiation at long wavelengths (heat) in a system, such as a greenhouse. The release of gases such as carbon dioxide into the atmosphere may lead to a similar outcome, increasing the Earth's temperature and leading to changes in climate.
- Hadron** A meson or baryon.
- Half-life** The time needed for half of the original number of atoms in a radioactive isotope to decay. Each radioactive element has a different half-life.
- Harmonic analysis** The breaking down of a complex wave into its simple sine-wave components.
- Harmonic wave** A wave shaped like a sinusoidal curve.
- Heat** Energy that flows from an object to another or to the surroundings when regions of different temperatures are involved.
- Heat engine** A device or motor that takes in energy (heat), converts some of that heat to mechanical work, and releases leftover waste heat at a lower temperature into the surroundings.
- Heat pump** The opposite of a heat engine, it moves heat from a colder reservoir to a warmer one by work supplied from an external source. A refrigerator is the best-known example.
- Heisenberg uncertainty principle** The position and momentum of a particle cannot both be known at the same time with high precision: if we are highly certain about the position of a particle, we will be almost completely uncertain about its momentum, and vice versa.
- Heliocentric** The revolutionary model of the solar system, proposed by Copernicus and championed by Galileo, that placed the sun rather than the Earth at the center of the planets' orbits. Ptolemy's obsolete model, in which the sun and other planets orbited the Earth, was a *geocentric* model.
- High-grade heat** Heat at temperatures of about 500°C or higher that can be used to run heat engines producing mechanical work or electrical energy.
- Hologram** A photograph of an interference pattern produced by a laser that forms a three-dimensional image when illuminated.
- Hypothesis** An educated guess or generalization grounded in experience and observation that can be tested to examine its consequences.
- Ideal gas** A gas in which the forces between atoms (and potential energy) are small enough to be ignored. The relation between properties such as temperature,

- pressure, and volume is summarized in the *equation of state* of an ideal gas,  $PV = NkT$ . Most real gases behave like ideal gases at sufficiently low pressures and high temperatures.
- Impulse** The force acting on an object multiplied by the time interval over which the force acts.
- Impulse-momentum principle** The impulse acting on an object produces a change in the object's momentum equal in both size and direction to the impulse.
- Index of refraction** A number that yields the speed of light in a transparent material ( $v = cn$ ). Different materials have different indices of refraction.
- Induction** The ability of an object to produce electric charge or magnetism in another by the action of its field rather than by touching.
- Inertia** An object's resistance to a change in its motion.
- Infrared light** Electromagnetic waves with wavelengths somewhat longer than red light of the visible spectrum.
- Instantaneous acceleration** The rate at which velocity is changing at a given instant in time.
- Instantaneous speed** How fast an object is moving at a particular instant. Instantaneous speed is related to *average speed* for very short time intervals.
- Instantaneous velocity** A vector quantity that is made up of an object's instantaneous speed and its direction at that instant.
- Insulator** A material that does not ordinarily permit a flow of charge through it.
- Integrated circuit** A single, tiny chip of semiconductor material housing many transistors, diodes, resistors, and electrical connections.
- Interference** The combination or interaction of two or more waves. In *constructive* interference, the waves add together. In *destructive* interference, the waves cancel each other.
- Internal energy** The sum of all kinetic and potential energies of the atoms and molecules inside a substance or system, uniquely determined by the state of the system.
- Ionize** To add or remove electrons from an atom or molecule.
- Isobaric** An adjective describing any process in which pressure is held constant.
- Isothermal** An adjective describing any process in which the temperature remains the same.
- Isotope** A variety of an element that has a specific number of neutrons that may differ from other isotopes of the same element. Carbon-12, the most common isotope of carbon, has six neutrons, while carbon-14 has eight.
- Just tuning** A tuning system based on the ideal frequency ratios between notes.
- Kinetic energy** The energy of an object related to its motion—one-half the mass multiplied by the square of the speed,  

$$KE = \frac{1}{2}mv^2.$$
- Kinetic force of friction** The frictional force between two objects sliding at the point of contact of their surfaces.
- Latent heat** The amount of heat needed to produce a phase change without a change in temperature. The *latent heat of fusion* melts a substance, and the *latent heat of vaporization* converts it to a gas.
- Law of reflection** When light is reflected from a smooth surface, the angle the reflected ray makes with the surface normal equals the angle the incident ray makes with the surface normal.
- Law of refraction** When light passes from one transparent medium to another, the rays are bent toward the surface normal if the speed of light is smaller in the second medium than in the first. The rays bend away if the speed of light in the second medium is greater than in the first.
- Lenz's law** A current opposes the change in magnetic flux producing it.
- Lepton** The lightest of subatomic particles—for example, electrons, positrons, and neutrinos.
- Lever arm** The perpendicular distance from the fulcrum to the line of action of the force—a component of torque; also called *moment arm*.
- Light clock** An "instrument" in a thought experiment about relativity that uses the speed of light over a set distance to define a basic unit of time.
- Linear displacement** A vector representing how far, and in what direction, an object has moved.
- Linear momentum** The product of the mass of an object and its velocity,  $p = mv$ ; also called *quantity of linear motion* by Newton.
- Linear motion** An object's motion from one point to another in a straight line.
- Low-grade heat** Heat at temperatures of about 100°C or lower that is best used to heat homes and buildings.
- Luminosity** An intrinsic, measurable property of a star independent of distance; the energy emitted per second by the star.
- Magnetic dipole** A magnet that consists of two equal magnetic poles, north and south, separated by a small distance, equivalent in its magnetic effects to a small electric-current loop.
- Magnetic field** The magnetic force per unit of charge and unit of velocity. It is a property of space in the region surrounding moving charges or a magnet.
- Magnetic flux** A measure of the number of magnetic field lines passing through an area bounded by a current loop or wire.
- Magnetic force** A force exerted by moving electric charges or currents on one another.
- Magnetic monopole** A particle with a single magnetic pole. Magnetic monopoles may have been present in the universe shortly after the Big Bang but probably no longer exist.
- Magnetic pole** A region of a magnet, usually labeled *N* or *S*, for *north-seeking* and *south-seeking*, that shows behavior similar to electric charge. Like poles repel; opposite poles attract.
- Magnification** The ratio of the height of an image produced by an instrument or lens to the object's actual height. The image can be either enlarged or reduced. In *negative* magnification, the image is inverted.
- Magnitude** The size of something expressed as a quantity.
- Mass** The measure of an object's inertia, the property that causes it to resist change in its motion. The kilogram is the basic metric unit for measurement of mass.
- Mass number** The total number of neutrons and protons in an element or its isotopes. Carbon-14 has 6 protons and 8 neutrons, yielding a mass number of 14.
- Mechanical advantage** The ratio of the output force to the input force of a simple machine.
- Mechanics** The branch of physics that studies forces and motion.
- Meson** A subatomic particle of intermediate weight—for example, a pion or a kaon. All mesons lack spin.
- Metric system** The International System of Units (*Système international d'unités*), abbreviated SI, is a decimal system of measurement. The seven fundamental SI units ("base units") are the meter (length), kilogram (mass), second (time), ampere (electric current), kelvin (temperature), mole (amount of substance), and candela (intensity of a light source).
- Microscope** An instrument that uses at least two positive lenses to produce a magnified image of a small object.
- Moderator** Material used in a nuclear reactor to slow down the neutrons produced in fission reactions.
- Modern physics** The subfields of physics—atomic, nuclear, particle, and condensed-matter—that largely came into existence and made great advances in the 1900s.

**Molecule** A combination of atoms of an element or of a chemical compound.

**Moment of inertia** The resistance of an object to change in its rotational motion that depends on an object's mass and the distribution of mass around the axis; also called *rotational inertia*.

**Muon** A type of lepton particle that is in the same family as the electron. It carries the same charge and spin as the electron but is more massive (by a factor of about 200). It is an elementary particle, meaning that it is a fundamental building block of matter and does not contain any smaller particles.

**Myopia** A condition in which the lens system of the eye is too strong, allowing people to see near objects clearly but not distant objects; also called *nearsightedness*.

**Natural radioactivity** Penetrating radiation produced without need of special preparation by ores or compounds containing radioactive elements.

**Negative lens** A lens that causes light rays to diverge more than when the rays entered the lens.

**Negative work** Work done by a force acting in a direction opposite to the object's motion.

**Net force** The vector sum of the forces acting on an object.

**Neutron** A particle with no charge, roughly the mass of a proton, in atomic nuclei.

**Newton** The metric unit of force: mass times acceleration, or kilograms times meters per second squared.

**Newton's first law of motion** Unless a force is applied, an object remains at rest or moves with constant velocity.

**Newton's law of universal gravitation** The gravitational force between two objects is proportional to the mass of each object and inversely proportional to the square of the distance between the centers of the masses:

$$F = \frac{Gm_1m_2}{r^2}$$

It is attractive and acts along the line that joins the two objects.

**Newton's second law of motion** The acceleration of an object is directly proportional to the magnitude of the imposed force and inversely proportional to the mass of the object,  $\mathbf{a} = \mathbf{F}_{\text{net}}/m$ , or  $\mathbf{F}_{\text{net}} = m\mathbf{a}$ .

**Newton's third law of motion** If object A exerts a force on object B, object B exerts a force on object A equal in magnitude and opposite in direction to the force exerted on B.

**Noble gas** Gases that do not react readily with other elements because their outer shells are closed. (See *shell*.) Found in column VIIIA of the periodic table, the noble gases are helium, neon, argon, krypton, xenon, and radon.

**Node** The point in a standing wave where there is no motion.

**Normal force** The component of force on an object that acts perpendicular to the surface of contact, as opposed to the frictional force, which acts parallel to it.

**Nuclear fission** A nucleus-splitting reaction accompanied by conversion of part of the mass of the nucleus to kinetic energy. The nucleus breaks into two roughly equal parts (the fission fragments) rather than just emitting a particle, as in most other nuclear reactions.

**Nuclear fusion** A reaction that combines small nuclei to produce somewhat bigger nuclei and a large release of energy.

**Nuclear physics** The subfield of physics devoted to the study of the nucleus of the atom.

**Nuclear reaction** Changes caused in the nucleus of atoms, which may result in one element turning into another.

**Nucleon** A particle that inhabits the atomic nucleus; a proton or neutron.

**Nucleus** The small, dense, positively charged center of an atom made up of protons and neutrons.

**Ohm's law** Current flowing through a portion of a circuit equals the voltage difference across that portion divided by the resistance,  $I = \Delta V/R$ .

**Optics** The subfield of physics devoted to the study of light and vision.

**Parallel circuit** A circuit with elements connected by more than one path, so that the current divides and rejoins.

**Partially inelastic collision** A collision in which some energy is lost, but the objects do not stick together after collision.

**Particle physics** The subfield of physics that studies subatomic particles (quarks, etc.).

**Pascal's principle** Any change in fluid pressure is transmitted uniformly in all directions in the fluid.

**Perfectly inelastic collision** A collision in which the greatest portion of energy is lost. Objects do not bounce at all but instead stick together after collision.

**Period** In astronomy, the time it takes for an object to return to the point where it started—for example, a complete planetary orbit; in physics, the time for a complete cycle, as of a wave.

**Periodic table of the elements** A table that orders the elements by atomic weight and atomic number. Beginning with hydrogen,

the lightest, the table also groups elements (in vertical columns in the typical format) with other elements with like properties.

**Periodic wave** A wave made of pulses separated by equal time intervals.

**Perpetual-motion machine of the first kind** A machine that would put out more energy as work or heat than it took in (a violation of the first law of thermodynamics and the conservation of energy).

**Perpetual-motion machine of the second kind** A machine that violates the second law of thermodynamics by claiming to convert heat completely to work or to surpass the Carnot efficiency.

**Phases of the moon** The appearance or aspect of the moon and other planets at given times in their cycles.

**Photon** A quantum of electromagnetic energy, especially a particle of light.

**Physical optics** The branch of optics that treats light as an electromagnetic wave to examine its effects and properties.

**Pion** A subatomic particle that comes in three charge states (positive, negative, and neutral). It has a mass of about 273 times the mass of an electron.

**Pitch** A musical term for height or depth of tone. The sound waves of notes with higher pitches have higher frequencies.

**Planck's constant** A constant  $h$ , which determines the size of a quantum of light energy for a given frequency, as summarized in the equation  $E = hf$ .

**Polarize** To separate positive and negative areas of charge on an object—for example, a magnetic or electrically charged body. In optics, to select a specific direction of oscillation of the electric field in a light wave.

**Polarized light** Light for which the electric field vector oscillates in a specific direction.

**Positive lens** A lens that causes light rays to converge more than when the rays entered the lens.

**Positron** The antiparticle of the electron. An elementary particle, with a positive electric charge, that in most other respects is identical to an electron. Positrons are important in medical imaging.

**Potential energy** Stored energy associated with the position of an object rather than the object's motion.

**Power** The rate of doing work, found by dividing the amount of work done by the time,  $P = W/t$ .

**Powers of 10** The basis of scientific notation, the powers of 10 give the multiples of 10 as superscripts or exponents: for example,  $10^4$  equals  $10 \times 10 \times 10 \times 10$ .

- Pressure** The ratio of a force to the area over which it is applied, or force per unit of area.
- Principle of equivalence** Part of the foundation of the general theory of relativity; it is impossible to distinguish an acceleration of a frame of reference from the effects of gravity. For example, the mass of an object measured by its inertia equals its mass measured by the action of a gravitational field on it.
- Principle of relativity** The laws of physics are the same in any inertial frame of reference.
- Principle of superposition** When two or more waves combine, the disturbance is equal to the sum of the individual disturbances.
- Projectile motion** The motion of an object that has been shot or thrown characterized by constant horizontal velocity combined with downward acceleration due to the Earth's gravity.
- Proper time** The time interval between two events measured in a frame of reference in which the two events occur at the same point in space.
- Proportion** A comparison of the ratio of quantities to one another or to a whole.
- Proton** A positively charged particle in atomic nuclei. The number of protons in a nucleus determines an atom's chemical properties.
- Quantized** To have formed into quanta, in particular to have restricted the number of possible values of a quantity, or states of a system, so that certain variables could only have assumed certain discrete magnitudes.
- Quantum mechanics** Mechanics (the study of forces and motion) applied to the atomic and nuclear level and dealing with photons and other quanta that show both wave and particle behavior.
- Quantum number** One of a set of numbers that relate properties of electrons or other particles at the subatomic level. These quantum numbers determine an electron's orbit—no two electrons of an atom can have the same set of quantum numbers.
- Quark** One of the particles that make up mesons and baryons (for example, neutrons and protons). There are six kinds of quarks.
- Radian** A unit of angular measurement found by dividing the distance traveled along an arc length  $s$  by the radius of the circle  $r$ , or  $s/r$ . One revolution =  $360^\circ = 2\pi$  radians.
- Radiation** The flow, emission, or propagation of energy by electromagnetic waves or particles.
- Radioactive decay** The change of an element into another element or state as a result of changes in its unstable atomic nucleus. There are three kinds of decay, named after their radioactive emissions: alpha (helium ions), beta (electrons), and gamma (electromagnetic waves). Any nucleus with more than 82 protons (the number in lead) is inherently unstable.
- Radius** A straight line from the center of a circle or sphere to its outer edge.
- Rate** One quantity divided by another, especially a quantity divided by a unit of time. Rates of time, like miles per hour and meters per second, are important in measuring motion.
- Ray tracing with lenses** A process used in optics to show what happens to a few light rays in order to locate the image formed by lenses.
- Ray tracing with mirrors** A process used in optics to show what happens to a few light rays in order to locate the image formed by mirrors.
- Reaction force** An oppositely directed force in response to the initial force in an interaction governed by Newton's third law of motion.
- Recoil** A brief interaction between two objects that causes them to move in opposite directions.
- Resistance** The property in a component in a circuit of opposing the flow of electric current and generating heat.
- Rest energy** Energy that an object has simply by virtue of its mass,  $E_0 = mc^2$ , an expression of mass-energy equivalence.
- Rest length** Length measured by an observer at rest relative to the distance measured.
- Restoring force** The force or system of forces that returns an object to equilibrium.
- Retrograde motion** The backward movement of a planet in its orbit, an illusion caused by the position of the planet with respect to the Earth.
- Reversible** Describes a thermodynamic process that is always near equilibrium and can be turned around and run the other way at any point in the process.
- Right-hand rule** To use the right-hand rule to determine the direction of the rotational velocity vector, hold your right hand with the fingers curling around the axis of rotation in the direction of the rotation; your thumb then points in the direction of the rotational-velocity vector.
- Rotational acceleration** The rate of change of rotational velocity.
- Rotational displacement** The angular measure of how far an object has rotated, usually expressed in radians.
- Rotational inertia** The resistance of an object to change in its rotational motion that depends on an object's mass and the distribution of mass around the axis; also called *moment of inertia*.
- Rotational velocity** The rate of rotation—how fast an object rotates. Revolutions per minute (rpm) is a common unit of measurement for it.
- Rydberg constant** A constant used in computing the wavelengths and the lines in atomic spectra, particularly for hydrogen.
- Scattering** A process in which light is absorbed and then re-emitted in different directions.
- Scientific method** The systematic study of phenomena by people engaged in science. The way scientists go about investigating phenomena normally begins with observation and experiments to test generalizations and hypotheses that can be incorporated into tested, comprehensive theories. Theories often predict new areas to explore.
- Scientific notation** A system for writing numbers succinctly and clearly that relies on the powers of 10; for example, 12 150 000 000 is written  $1.215 \times 10^{10}$ .
- Second law of thermodynamics** No engine working in a continuous cycle can take heat from a reservoir at a single temperature and convert that heat completely to work (Kelvin's statement). Heat will not flow from a colder to a hotter body unless some other effect is also involved (Clausius's statement).
- Selective absorption** A process in which some wavelengths of light are absorbed more than other wavelengths.
- Self-induction** Voltage induced in the same coil that produces the changing magnetic flux.
- Semiconductor** A substance with properties intermediate between those of electrical insulators and conductors. A fast-growing use of semiconductors is computer chips, where their properties can be customized.
- Series circuit** A circuit connected in a single loop, so that current passes through each component in succession.
- Simple harmonic motion** The motion of a system whose energy changes smoothly from potential to kinetic energy and back again. The motion is symmetric about the point of equilibrium and is graphed as a sinusoidal curve.
- Simple machine** Any elementary mechanical device that multiplies the effect of an applied force—for example, levers, wedges, and pulleys.
- Sinusoidal curve** The graph of the trigonometric sine function that illustrates simple harmonic motion. The graph of alternating current is a sinusoidal curve. Also called a *sine curve*.

- Slope** The change in the vertical coordinate of a graph divided by the change in the horizontal coordinate. In a graph of an object's position plotted against time, the slope at a point indicates how fast the object is moving.
- Sound wave** A longitudinal wave that propagates pressure variations through air or other media. Humans generally hear sound waves from 16 Hz to 20,000 Hz in pitch.
- Space-time continuum** A four-dimensional framework for describing an event that recognizes that the three dimensions of space and time are not independent of one another and that space is curved.
- Special theory of relativity** Einstein's "limited" theory, based on two basic postulates: The laws of physics have the same form in any inertial frame of reference (the principle of relativity), and the speed of light is the same in any inertial frame of reference.
- Specific heat capacity** A property of a material that is the quantity of heat needed to change a unit of mass by a unit of temperature (for example, to change 1 g of a substance by 1°C).
- Speed** How fast something is moving without regard to direction of motion—not a synonym for *velocity*.
- Spring constant** A constant describing the relation between how far a spring is stretched or displaced and how much force it takes to do the stretching: a stiff spring has a large spring constant.
- Standard model** The evolving framework in use for exploring the fundamental forces and particles at the subatomic level; it includes theories of quarks, the electroweak force, and the strong nuclear interaction.
- Standing wave** An unchanging pattern of waves or oscillations formed by interference of waves traveling in opposite directions.
- Static force of friction** A frictional force that does not involve motion in the direction of the force.
- Strong nuclear interaction** A fundamental force that binds together the quarks in neutrons and protons (and other baryons and mesons).
- Subtractive color mixing** The production of different colors by absorbing different wavelengths from white light.
- Superconductivity** The loss of all electric resistance to the flow of current below a critical (usually very low) temperature.
- Superfluid** A fluid that loses its viscosity at a very low temperature.
- Surface normal** A line drawn perpendicular to a surface.
- Synchronous orbit** An orbit timed to a planet's rotation to keep a satellite above the same point on the planet's surface.
- Telescope** An instrument that uses two or more lenses or mirrors to bring much closer to the eye an image of a distant object.
- Temperature** A quantity that tells which direction heat will flow. If two objects are at different temperatures, heat flows from the higher to the lower temperature.
- Terminal velocity** The point at which air resistance on a falling object equals the gravitational force, producing a net force of zero, which ends the object's acceleration. The object will continue down at constant velocity.
- Theory** An organized set of principles used to explain known facts and to predict new phenomena as a guide to further investigation.
- Thermal conductivity** The property of a substance that determines how swiftly it conducts heat. Metals are better conductors than wood or plastic.
- Thermal equilibrium** The state at which the physical properties, such as volume, of objects no longer vary with regard to each other, and the objects reach the same temperature.
- Thermal power plant** A facility that produces electricity by utilizing heat obtained from sources such as coal, oil, natural gas, nuclear fuels, or geothermal energy to run a heat engine.
- Thermodynamics** The subfield of physics concerned with temperature, heat, and energy.
- Thin-film interference** Interference of light reflected from the top and bottom surfaces of a very thin film of a transparent material.
- Torque** The product of a force and its lever arm ( $\tau = Fl$ ) that causes an object to rotate.
- Trajectory** The path of a projectile or other object in motion.
- Transformer** A device that steps (adjusts) alternating-current voltage up or down to suit the needs of a particular application.
- Transistor** An electronic device made from semiconductors that carries out a number of functions, including producing variations in electric current, amplifying radio signals, and serving as a voltage-controlled switch.
- Turbulent flow** The more complicated, less smooth flow of a fluid caused by random fluctuations usually resulting from an increase in speed or a decrease in viscosity.
- Ultraviolet light** Electromagnetic waves with wavelengths shorter than violet light of the visible spectrum.
- Unified field theory** The theory seeking to unite the four fundamental forces—the strong nuclear interaction, electromagnetic force, gravitational force, and weak nuclear force—that relies on the behavior of their fields to explore and analyze them.
- Uniform acceleration** Acceleration with a steady rate of change in velocity, the simplest kind of accelerated motion.
- Universal gravitational constant** A constant  $G$  that equals  $6.67 \times 10^{-11} \text{ N}\cdot\text{m}^2/\text{kg}^2$ . Because this constant is so small, gravitational forces between two objects of ordinary size are almost unnoticeable.
- Unpolarized light** Light for which the electric field vector oscillates in random directions.
- Vector** A quantity that has both magnitude and direction, often represented by an arrow. The length of the arrow is proportional to the size of the vector quantity, and the angle shows its direction.
- Vector quantity** Any quantity, such as velocity or a force, for which *both* the size and the direction are needed for a complete description.
- Velocity** A vector quantity that describes how fast an object is moving *and* which direction it is moving.
- Viscosity** A measure of the frictional forces between the layers of a fluid producing resistance to flow. Highly viscous liquids flow slowly.
- Voltage** A change or difference in electric potential measured in volts.
- Wave pulse** A single, brief wave traveling through a substance or system.
- Wavefront** A surface within a wave for which all points are at the same phase (stage of oscillation).
- Wavelength** The distance between the same points of successive pulses in a wave. Its symbol is  $\lambda$ .
- Weak nuclear force** A fundamental force involved in the interactions of leptons in beta decay.
- Weight** The gravitational force on an object; in symbols,  $\mathbf{W} = mg$ .
- Work** The force applied to an object times the distance moved,  $W = Fd$ . The force acts along the object's line of motion. The joule is the metric unit of work.
- X-rays** Highly penetrating electromagnetic waves with a very short wavelength, now widely used in medicine to take pictures of internal organs and bones.
- Zeroth law of thermodynamics** A basic assumption of thermodynamics: Objects in thermal equilibrium have the same temperature.





# Index

## A

- absolute temperature, 196, 197, 204–205, 221
- absolute zero, 195–196
- absorption
  - light waves and, 326, 332, 337, 348
  - nuclear reactions and, 420–422, 426
- absorption lines, 463
- acceleration, 19
  - air resistance and, 41–42
  - average, 25
  - bouncing ball and, 125
  - centripetal, 27, 81–87
  - constant speed and, 27
  - curves and, 27, 81
  - deceleration and, 26, 46
  - direction of, 26
  - electrostatic force and, 251
  - falling objects and, 39–48
  - force and, 63–64
  - free fall and, 17, 31, 32, 44, 62
  - graphing of, 28–29
  - gravitational, 17, 39–48, 61–62, 66–67, 93–94
  - instantaneous, 25–26
  - momentum and, 125–140
  - Newton’s first law of motion and, 63, 64, 66
  - Newton’s law of universal gravitation and, 17, 61–62, 91–94
  - Newton’s second law of motion and, 63–64, 67, 70, 81–82, 84
  - Newton’s third law of motion and, 68–71
  - principle of equivalence and, 449–450
  - projectile motion and, 48–50
  - as rate of change of velocity, 47
  - skydivers and, 72–73
  - stroboscopes and, 39–40
  - tablecloth trick and, 65
  - uniform, 31–32, 39
  - zero, 46–47
- accident dynamics, 86
- action potential, 265
- action/reaction principle, 68–71
- additive color mixing, 337, 338
- air bags, 86, 129
- air resistance, 41–42, 72
- algebra, basic concepts, A-1–A-2
- alkali metals, 387
- alpha particles
  - atomic structure and, 394–396
  - bombardment of beryllium, 417
  - decay and, 412–413
  - health hazards, 416
  - nuclear fusion, 426–427
  - positive charge, 412
  - radioactive decay, 412–413
  - scattering experiments, 409–410
  - in smoke detectors, 414
- alternating current (ac), 274–278
- alternative voltage, 300
- American Journal of Physics*, 53, 187
- americium, in smoke detectors, 414
- ammeters, 271
- amperage. *see* electric current
- ampere (A), 290
- Ampère, André Marie, 237, 262, 289, 293, 295, 333
- amplitude, 117
- angular momentum
  - bicycles and, 158–161
  - changes in rate of spin and, 156–157
  - conservation of, 155–158
  - defined, 155–156
  - direction of, 158
  - Kepler’s second law and, 157–158
  - as quantity of motion, 155
  - rotational motion and, 13, 155–158, 399, 401, 403
  - spinning tops and, 161
  - vectors and, 158
  - yo-yos and, 159
- animal electricity, 237
- antineutrinos, 413
- antinodes, 317–318, 322, 323
- antiparticles, 413, 460
- antireflection coatings, 343
- apertures, 345, 374
- Aquinas, Thomas, 61
- Arago, Dominique-François, 293
- Archimedes’ principle, 178–181
- Aristotle, 17, 62
  - Galileo and, 61
  - gravitational acceleration and, 41–42
  - motion and, 60–61, 73
  - Newton and, 60
- astronomy, gravity waves, 452
- atmospheric pressure
  - altitude and, 176
  - barometers and, 176
  - Boyle’s law and, 177
  - measurement of, 174–176
  - variations in, 176
  - volume and, 177
  - weight of air column and, 177
- atomic bomb, 381
- atomic mass, 385, 387, 409–410, 412, 417–418
- atomic number, 412–413, 417
- atomic spectra, 396–399, 402–403
- atomic structure, discovery of nucleus, 458
- atomic weight, 384–385, 387–388
- atoms
  - alpha particles and, 394–396
  - ancient Greeks and, 381, 383
  - beta particles and, 394, 396, 413–415, 460, 461
  - Big Bang theory and, 464
  - Bohr model of, 381, 396–399
  - cathode rays and, 389–393, 396
  - chemistry studies and, 383–389
  - de Broglie waves and, 400–401
  - electrons and, 207, 241. *see also* electrons
  - electroweak force and, 461
  - elementary particles and, 458–461
  - elements and, 384–389, 393, 394, 399, 403
  - gamma rays and, 335, 394, 396, 410, 413–415
  - Heisenberg uncertainty principle and, 402
  - inferring existence of, 383–389
  - molecules and, 7, 94. *see also* molecules
  - natural radioactivity and, 392
  - neutrons and, 410, 417–418, 458–459
  - nucleus and, 393. *see also* nucleus
  - particle waves and, 400–403



- atoms—*Cont.*  
 photons and, 307, 398, 400–401, 413, 415  
 Planck's constant and, 398, 399, 400–402  
 positrons and, 413, 417, 458–460  
 protons and, 386–387, 458–460  
 radioactivity and, 392, 393–396  
 strong nuclear interaction and, 461  
 stylized model of, 383  
 weak nuclear force and, 461  
 X-rays and, 392–393
- automobiles  
 collisions and, 137  
 Doppler effect and, 321  
 heat engines and, 216–217  
 hybrid, 218  
 induction coils and, 297  
 vehicle sensors and, 298
- average acceleration, 25  
 average speed, 19–21  
 average velocity, 40–41  
 axons, 264–265
- B**
- balance, 149–150, 151–152  
 balloons, 181, 203, 206  
   theory of expanding universe, 464  
 balls, dropped ball in elevator, 449  
 Balmer, J. J., 397  
 Balmer series, 397, 399  
 banked curves, 85  
 Bardeen, John, 467  
 barium, nuclear fission, 418–419  
 barium titanate, 470  
 barometers, 176  
 baryons, 460, 464  
 base, 466  
 basketballs, 52–53  
 batteries, 387  
   dead, 267  
   electric circuits and, 261–279  
   electric energy and, 272–274  
   power and, 272–274  
   smoke detector, 414  
   Volta and, 288  
 beat, 326  
 Becker, Wilhelm, 410  
 Becquerel, Antoine-Henri, 393, 396, 412  
 bell laboratories, 466  
 Bernoulli, Daniel, 184  
 Bernoulli's principle, 184–186  
 beryllium  
   alpha particle bombardment, 410, 417  
   atomic mass units, 417–418  
   protons and neutrons, 410
- beta particles  
 atomic structure and, 394, 396  
 decay and, 413–415, 460, 461  
 nucleus and, 410, 413–415
- beta rays  
 health hazards, 416  
 radioactive decay, 413–415
- bicycles, 2, 9, 12, 13, 112, 158–162, 173, 193  
 Big Bang theory, 464  
 Big Dipper, 87  
 bimetallic strips, 275  
 binoculars, 374–375  
 birefringence, 348–349  
 bismuth, radioactive decay, 413–415  
 blackbody, 398  
 black holes, 452, 464  
 blood pressure, 175  
 blue sky, 336, 339  
 Bohr, Niels, 381, 396, 420  
 Bohr model  
   atomic structure and, 381, 396–400  
   features of, 398–399  
   quantum mechanics and, 400–403
- boiling point, 194, 199  
 boron, 465  
 Bothe, Walther, 410  
 Boyle, Robert, 177  
 Boyle's law, 177  
 Brahe, Tycho, 89–90  
 Brancazio, Peter J., 53  
 Brattain, Walter H., 467  
 bridge, 323  
 brushes, 294  
 bullets, 50–51  
 buoyant force, 178–180  
 buoys, 311
- C**
- caloric model, 196–197, 220  
 calories, 203  
 capacitors, 251  
 carbon, protons and neutrons, 412  
 carbon dioxide  
   alternatives fuels and, 227  
   circulatory system and, 175  
   electrostatic precipitators and, 244  
   fossil fuels and, 227, 386  
   greenhouse gases and, 3, 209, 245  
   molecular structure of, 385
- Carnot, Sadi, 169, 220, 222  
 Carnot efficiency, 221, 225–228  
 Carnot engines, 220–222  
 carpet fireworks, 241  
 cathode rays, 389–393, 396  
 Cavendish, Henry, 93  
 cell membrane, 264–265  
 cell phones, 237, 335, 458, 464, 468  
 Celsius, Anders, 194  
 Celsius temperature scale, 194–195  
 center of gravity, 151–152  
 centrifugal force, 438  
 centripetal acceleration, 27  
   defined, 82  
   Newton's first law of motion and, 81
- Newton's law of universal gravitation  
   and, 92–93  
 Newton's second law of motion and,  
   81–82, 84–85  
 planetary motion and, 87–94  
 size of, 82–83  
 tension and, 81–84
- centripetal forces  
 banked curves and, 85  
 defined, 84  
 Ferris wheel and, 85, 87  
 kinetic force of friction and, 84–85  
 static force of friction and, 84–85
- Cepheid variables, 463  
 ceramic superconductors, 469–470  
 CERN, 459, 460, 464  
 Chadwick, James, 410, 411  
 chain reactions, nuclear, 420–421, 425  
 change of phase, 198–199  
 chaos theory, 184  
 chemistry  
   atomic number and, 412–413, 417–419,  
     421, 426  
   atoms and, 383–384  
   combustion and, 384  
   conservation of mass and, 384  
   Dalton and, 384–385  
   defined, 383  
   elementary, 383  
   isotopes and, 411–412  
   Lavoisier and, 384  
   law of definite proportions and, 385  
   mass number and, 412–413, 417, 421  
   Mendeleev and, 388  
   noble gases and, 403  
   periodic table of elements, 387–389,  
     402–403, A-20. *see also* elements  
   quantum mechanics and, 402–403
- chip, 467  
 chlorine, protons and neutrons, 412  
 chromodynamics, quantum, 460  
 circuit breakers, 277  
 circulatory system, 175  
 Clausius, Rudolf, 169, 224–225  
 climate change  
   energy conservation and, 12, 13  
   global warming and, 3, 169, 209, 245  
   greenhouse gases and, 3, 209, 245, 385  
   nuclear power *versus* fossil fuels, 423  
   political debate over, 4
- cloud chambers, 458  
 coffeemaker, 7  
 cold fusion, 428, 468  
 collectors, 466  
 collisions  
   angle, at an, 135–139  
   automobile, 137  
   bouncing ball and, 125  
   elastic, 133–135, 138–139  
   heat and, 134  
   inelastic, 133–135

- kinetic energy and, 133–134  
momentum and, 125–140  
recoil and, 131–133  
two-dimensional, 136–139
- color, 2  
additive mixing and, 337, 338  
blue sky and, 336, 339  
differentiation of, 336–337  
diffusion and, 338  
human eye and, 336–337  
Newton and, 336, 338  
selective absorption and, 337–338  
specular reflection and, 338  
subtractive mixing and, 338  
thin films and, 341–342  
wavelength and, 336–338
- combustion, 384  
compasses, 288–289  
computers, 458, 467–468  
concave mirrors, 366–368  
conduction, 206–207  
conductivity, 266  
material property, 465  
conductors, 242–244, 464–468  
cones, 336–337  
connected objects, 73–74  
conservation of angular momentum, 155–158  
conservation of energy, 3, 13, 103  
concept of energy and, 111–113  
defined, 110–111  
electric circuits and, 272–273  
fluids and, 169  
harmonic motion and, 115–118  
momentum and, 133–134, 138  
pendulums and, 110–111  
conservation of mass, 384  
conservation of momentum, 128–130, 139  
special theory of relativity, 446  
constructive interference, 316  
continuity of flow, 181–184  
control rods, 421  
convection, 207–208  
converging lenses, 364–365  
conversion factors, A-18–A-20  
convex mirrors, 368–369  
coolants, 422–423  
Copernicus, Nicolaus, 17, 61, 88–89  
copper, superconductors, 469–470  
cornea, 336, 370–371  
corona, 245  
cosmic rays, 459  
cosmology  
beginning of universe, 463–464  
black holes, 452, 464  
defined, 461  
expanding universe, 462–463  
galaxies, 462–463  
coulomb (C), 247  
Coulomb, Charles, 246, 248, 288  
Coulomb's constant, 247, 333  
Coulomb's law  
atoms and, 396  
electric field and, 244–248  
electromagnetic waves and, 333  
magnetic force and, 286–287  
critical mass, 425  
critical reactors, 421  
critical temperature, 469  
crystals  
compasses and, 287  
dichroic, 347  
exotic, 470–471  
heat packs and, 200  
ice, 206  
integrated circuits and, 467  
liquid, 470–471  
plastic, 471  
semiconductors and, 465  
superconductors and, 470–471  
waves and, 320, 347, 348–349, 401  
Curie, Marie, 394, 412  
Curie, Pierre, 394, 412  
curveballs, 186
- D**  
Dalton, John, 384–385  
Dalton's law of definite proportions, 385  
daughter elements, 413  
Davy, Humphry, 295  
de Broglie, Louis, 400  
de Broglie wavelength, 401  
de Broglie waves, 400–401  
deceleration, 26  
decimal fractions, A-3  
dendrites, 264  
density  
Archimedes' principle and, 178–181  
atmospheric pressure and, 174, 176, 177  
Boyle's law and, 177  
buoyancy and, 178–180  
defined, 174  
flowing fluids and, 181–184  
mercury and, 174  
destructive interference, 316  
deuterium, 422, 426, 428  
diffraction, 343–346  
diffraction grating, 345–346  
diffusion, 338  
diodes, 466  
Dirac, Paul, 458  
direct current (dc), 274  
direct-current motors, 294  
dispersion, 361–362  
distance  
diverging lenses, 365  
falling objects and, 42–43  
image formation and, 355, 362–366  
maximum in projectile motion, 52–54  
measurements for different observers, 444–445  
mirrors and, 357  
motion and, 29, 32  
object, 357  
stopping distance for moving car and, 107  
work and, 104  
doping, 465  
Doppler effect, 321, 463  
double-slit experiment, 340–341
- E**  
Earth  
Copernican model and, 17, 61, 88–89  
cosmology and, 461–464  
eclipses and, 94  
luminiferous ether and, 438–439  
as magnet, 287–288  
Newton's law of universal gravitation and, 92–93  
weight of, 93  
earth  
speed of light, 442–443  
velocity relative to, 437–438  
Earth years, 91  
eclipses, 94  
eddies, 184  
Edison, Thomas Alva, 273, 301  
efficiency, 339  
Carnot engine, of, 221  
defined, 217  
electric motors and, 228  
energy use and, 3  
heat engines, of, 217  
industrial pollution and, 245  
second law of thermodynamics and, 221–222  
traffic flow and, 298  
transformers and, 301  
turbines and, 422  
waste heat and, 217, 226  
egg toss, 129  
Einstein, Albert, 17, 400  
mass-energy equation of, 417, 420, 447–448  
postulates of, 440–442  
prediction of gravity waves, 452  
principle of equivalence and, 449–450  
quantum mechanics and, 398  
relativity and, 435, 461  
scientific contributions, 433  
speed of light and, 438–442  
thought experiments, 442–445  
elastic collisions, 133–139  
elastic potential energy, 109–110  
electric, potential, 251–254  
electric charge, 239–242  
cathode rays and, 389–393  
current and, 262–263

- electric charge—*Cont.*  
 discharging of, 241–242, 244, 254–255  
 electromagnetic waves and, 332–333  
 induction and, 243–244  
 lightning and, 254–255  
 negative, 241–242  
 neutral, 241  
 positive, 241–244  
 quarks and, 460–461
- electric circuits  
 alternating current and, 274–278  
 ammeters and, 271  
 appliances and, 275, 277–278  
 batteries and, 261–279  
 bimetallic strips and, 275  
 circuit breakers and, 277  
 as closed loop, 261  
 electric current and, 261–266  
 energy transformations in, 272  
 flashlights and, 262  
 flowing water analogy for, 263, 265, 272  
 fuses and, 277  
 lightbulbs and, 261–262  
 Ohm's law and, 266–267, 272  
 parallel, 269–270  
 power and, 272–274  
 resistance and, 266–267  
 series, 268–269  
 voltmeters and, 271
- electric current  
 alternating (ac), 274–278  
 ampere unit (A) and, 289–290  
 batteries and, 274–276  
 conducting path and, 262  
 conductivity and, 266–267  
 defined, 262–263  
 direct (dc), 274  
 effective, 274–276  
 Faraday's law and, 295, 299  
 household wiring and, 276–278  
 insulators and, 263  
 magnetic effects of, 288–295  
 magnetic torque and, 287, 291–293  
 Ohm's law and, 266, 272  
 resistance and, 266–267
- electric dipole, 244, 250, 287
- electric field  
 component vector and, 347  
 concept of, 248  
 corona, 245  
 Coulomb's law and, 244–248  
 direction of, 249–250  
 electric potential and, 252–253  
 electromagnetic waves and, 332–333  
 external force and, 251  
 Faraday and, 249  
 luminiferous ether and, 438–439  
 Maxwell and, 249  
 parallel field lines and, 251
- electric fields, particle accelerators, 458–459
- electricity  
 animal, 237  
 barium titanate and, 470  
 distribution of, 273–274  
 Faraday's law and, 294, 296, 299–300  
 generators and, 299–301, 311  
 nerve cells and, 264–265  
 power and, 272–274  
 semiconductors and, 464–468  
 superconductors and, 468–471  
 transformers and, 300–301  
 waves and, 310–311
- electric motors, 387  
 back voltage and, 294  
 brushes and, 294  
 direct-current, 294  
 efficiency of, 228  
 electric circuits and, 261, 274–278  
 Faraday's law and, 294  
 hybrid automobiles and, 218  
 magnetism and, 285, 291–292, 295  
 ponds, 230  
 refrigerators and, 222–223  
 split-ring commutators and, 294  
 starters and, 218–219
- electric potential, 251–254
- electric power, 272–274
- electrodynamics, quantum, 460
- electromagnetic force, 285
- electromagnetic induction, 295–299
- electromagnetic spectrum, 209, 334–335
- electromagnetic waves, 208  
 Ampère and, 333  
 Coulomb's law and, 333  
 electric field and, 332–333  
 Faraday's law and, 294, 296, 299–300, 332  
 Fizeau and, 334  
 Hertz and, 333  
 kinds of, 334–335  
 light as, 438  
 magnetic field and, 332–333  
 Maxwell and, 332–335  
 motion and, 332  
 propagation of, 333  
 speed of, 333–334, 438–442
- electromagnets, 293, 295
- electromotive force, 266–267
- electron gun, 390  
 atomic structure and, 381, 386–387, 396, 398–399, 401–403  
 beta particles and, 394, 396  
 cathode rays and, 389–393, 396  
 de Broglie waves and, 400–401  
 discovery of, 381, 389, 392  
 mass of, 392  
 photoelectric effect and, 400  
 Planck's constant and, 398–399, 400–402  
 quantum number and, 402–403
- electrons  
 beta particles and, 410, 413–415, 460  
 Big Bang theory and, 464  
 cosmology and, 461–464  
 discovery, 458  
 discovery of, 458–459  
 electric circuits and, 262–263, 265, 272–273  
 electrostatic phenomena and, 241–242  
 elementary particles and, 458–461  
 Franklin model and, 241  
 heat flow and, 207  
 kinetic energy and, 207  
 mass of, 410  
 semiconductors and, 464–468  
 spin of, 293, 295  
 superconductivity and, 468–470  
 waves and, 307
- electron volts (eV), 399, 459
- electroscopes, 240–241, 246
- electrostatic force  
 acceleration and, 251  
 atoms and, 396  
 conductors and, 242–244  
 corona, 245  
 corona and, 245  
 Coulomb's law and, 244–248  
 defined, 240  
 dry hair and, 239  
 effects of electric charge and, 239–242  
 electric dipole and, 244  
 electric field and, 248–250, 253–254  
 electric potential and, 251–254  
 electrons and, 241–242  
 electroscopes and, 240–241, 246  
 Franklin's single-fluid model and, 241–242  
 hair-and-comb fireworks, 239  
 induction and, 243–244  
 insulators and, 242–244  
 lightning and, 254–255  
 measurements, 240–241, 246–247  
 negative charge and, 241–242  
 pith ball experiments and, 239–240  
 polarized material and, 244  
 positive charge and, 241–242  
 unified field theory and, 248
- electrostatic precipitators, 244, 245
- electroweak force, 461
- elementary particles  
 baryons, 459–460, 464  
 Big Bang theory and, 464  
 cloud chambers and, 458  
 discovery, 458–459  
 electrons, 458  
 electroweak force and, 461  
 fundamental forces, 461  
 grand-unified theories, 461  
 hadrons, 460  
 kaons, 460  
 kinds of, 459–461

- leptons, 459–461  
 mesons, 460, 464  
 muons, 458, 460  
 particle accelerators and, 458–459, 470  
 pions, 458, 460, 463  
 positrons, 413, 417, 458–460  
 protons, 458–460, 464  
 quarks, 458–461, 464  
 scattering experiments and,  
 458–461, 472  
 standard model, 458–461  
 unified field theory and, 248  
 weak nuclear force and, 461
- elements, 399, 402–403, 470  
 atomic mass and, 385, 387, 409–410,  
 412, 417–418  
 atomic number and, 412–413, 417–419,  
 421, 426  
 atomic weight and, 384–385,  
 387–389  
 daughter, 413  
 isotopes and, 411–412, 464  
 mass number and, 412–413, 417, 421  
 periodic table, A-20  
 periodic table of, 387–388, 465  
 radioactive decay and, 412–417  
 radioactivity and, 392  
 semiconductors and, 464–468
- elevators, dropping a ball inside, 449
- ellipses, 89–90
- emitters, 466
- empirical laws, 5
- energy  
 alternative fuels and, 227–228  
 Big Bang theory and, 464  
 collisions and, 133–134  
 conservation of, 3, 13, 103, 110–115,  
 133–134, 138, 169, 272–273  
 definition of, 3  
 electric, 272–274. *see also* electricity  
 electron volts (eV) and, 399  
 entropy and, 216, 224–225  
 food calories and, 203  
 fossil fuels and, 3, 169, 206, 209,  
 227–228, 273, 310, 386–387  
 geothermal, 227  
 global warming and, 3, 169, 209,  
 245, 386  
 heat, 198. *see also* heat  
 internal, 110, 202–203, 217, 219, 223,  
 226, 229, 272  
 kinetic, 103, 106–107. *see also* kinetic  
 energy  
 lightning, 254–255  
 magnetic effect and, 301. *see also*  
 magnetic effect  
 momentum and, 125–140  
 nuclear, 3, 112, 227, 393  
 pendulums and, 103, 110–111  
 perpetual motion and, 228–230  
 photons and, 307, 398, 400–401, 402
- Planck's constant and, 398–399,  
 400–402  
 pole vaulting and, 114  
 potential, 103, 108–110, 184–185,  
 201–203, 230, 262, 263, 272–274, 310  
 power and, 105–106. *see also* power  
 quantization of light and, 398  
 rest, 448  
 thermal power plants and, 227–228  
 thermodynamics and, 206–207. *see also*  
 thermodynamics  
 transportation and, 3  
 using concept of, 111–113  
 work and, 103–106
- enrichment of uranium, 422
- entropy, 216, 224–225
- environmental issues, nuclear reactors, 423
- epicycles, 88–89
- equally tempered tuning, 325
- equation of state, 205, 206
- equations  
 acceleration, 25, 44, 83  
 angular momentum, 156  
 average speed, 19  
 Bernoulli's principle, 185  
 Boyle's law, 177  
 centripetal acceleration, 83  
 Coulomb's law, 247  
 distance during uniform acceleration, 44  
 distance traveled, 32  
 efficiency, 217, 225  
 Einstein's mass-energy, 417, 447  
 electric current, 262–263  
 electric field, 249  
 electric potential, 252  
 electric power, 272  
 Fahrenheit/Celsius conversion, 195  
 first law of thermodynamics, 202  
 force, 64  
 frequency, 312  
 fringe pattern, 344, 346  
 gravitational acceleration, 41  
 Heisenberg uncertainty principle, 402  
 impulse, 126  
 index of refraction, 358  
 induced voltage, 296  
 kinetic energy, 106  
 length contraction, 444  
 magnetic flux, 296  
 magnetic force between parallel  
 wires, 289  
 momentum, 126  
 Newton's law of universal gravitation, 92  
 Ohm's law, 266  
 parallel resistance, 270  
 path difference, 341  
 potential energy, 109  
 pressure, 171  
 quantum energy, 400  
 rate of flow, 182  
 rotational acceleration, 147
- rotational velocity, 147  
 series resistance, 269  
 speed of light, 359  
 time dilation, 442–443  
 torque, 150, 154  
 transformer analysis, 300–301  
 wave speed, 312  
 weight, 67  
 work, 104
- ether, 438–442
- everyday phenomena  
 accident dynamics, 86, 137  
 antireflection coatings, 343  
 automobile collision, 137  
 bicycle gears, 162  
 blood pressure, 175  
 blue sky, 339  
 coffemaker, 7  
 common sense and, 13  
 conservation of energy, 112  
 curveballs, 187  
 direct-current motors, 294  
 Doppler effect, 321  
 egg toss, 129  
 electrical impulses in nerve cells, 264–265  
 electric power from waves, 310  
 fuel cells, 386–387  
 Fukushima Daiichi nuclear disaster,  
 424–425  
 global warming, 209  
 greenhouse, 209  
 holograms, 471–472  
 laser refractive surgery, 372  
 lightning, 254–255  
 100-m dash, 30  
 pole vault energy, 114  
 rainbows, 362–363  
 reaction time, 44–45  
 riding an elevator, 70  
 scaling recipe, 11  
 shooting a basketball, 52–53  
 smoke detectors, 414  
 smoke emissions, 245, 414  
 solar collectors, 209  
 tablecloth trick, 65  
 television development, 390  
 tides, 96  
 toasters, 275  
 transitions in traffic flow, 22  
 twin paradox, 446–447  
 vehicle sensors at traffic lights, 298  
 yo-yos, 159
- expanding universe, 462–463  
 exponential decay, 415  
 extraordinary waves, 348  
 eyeglasses, 343
- F**  
 Fahrenheit, Gabriel, 194  
 Fahrenheit temperature scale, 193–195

- falling objects  
 air resistance and, 41–42  
 Aristotle on, 41–42  
 distance traveled in different times, 42–43  
 free fall and, 17, 31, 32, 44, 62  
 Galileo on, 39, 41–42  
 gravitational acceleration and, 39–48  
 throwing a ball downward, 43–45  
 throwing a ball upward, 46–48  
 tracking, 42–46  
 velocity variance with time, 42
- Faraday, Michael, 237, 249
- Faraday's law  
 electric motor and, 294  
 electromagnetic waves and, 294, 296, 332  
 generators and, 299–301  
 induction and, 296
- farsightedness, 370–371
- Fat Man, 426
- Fermi, Enrico, 418, 420, 421
- Fermilab, 459, 460
- Ferrer, Ricardo, 187
- Ferris wheels, 85, 87, 146
- ferromagnetic materials, 293. *see also* magnetic effect
- field lines, 249–250, 287–288, 291, 299
- fifth harmonic wave, 318, 324
- first harmonic wave, 317, 323
- first law of thermodynamics, 201–203  
 gas behavior and, 203–206  
 heat engines and, 217–219, 228–229  
 internal energy and, 217–219, 223, 225, 229  
 perpetual motion and, 228–230
- fission  
 chain reaction and, 420–421  
 discovery of, 418–420  
 nuclear energy and, 409, 417–428, 433, 448
- fission fragments, 419, 422, 423, 425
- fixed stars, 87–88
- Fizeau, Armand-Hippolyte, 334
- flashlights, 261  
 velocity of light, 441–442
- floating, 178–181
- flow, 181–182  
 Bernoulli's principle and, 184–186  
 laminar, 183–184  
 turbulent, 183–184  
 water nozzles and, 185
- fluids, 169  
 Archimedes' principle and, 178–181  
 Bernoulli's principle and, 184–186  
 buoyancy and, 178–180  
 equation of state and, 205, 206  
 flow and, 181–184  
 Franklin's single-fluid model and, 241–242  
 gases and, 173–174. *see also* gases  
 heat engines and, 216–231  
 hydraulic jacks and, 172–173  
 liquids and, 179. *see also* liquids  
 in motion, 181–184  
 Pascal's principle and, 172, 179  
 pressure and, 171–178, 185  
 sound waves and, 319–322  
 viscosity and, 182–183
- focusing  
 curved mirrors and, 366–369  
 focal length, 362–366, 371, 374  
 focal point, 363–367, 369, 371  
 lenses and, 362–366
- footballs, 51–52
- force  
 acceleration, 26, 63–64, 81–87  
 action/reaction principle and, 68–71, 130  
 addition of, 64, 66  
 Big Bang theory and, 464  
 buoyancy, 178–180  
 connected objects and, 73–74  
 conservation of energy and, 110–115  
 conservative, 110  
 defining, 62–64  
 elastic, 109–110  
 electromagnetic, 285, 461  
 electromotive, 266–267  
 electrostatic, 239–256  
 electroweak, 461  
 frictional, 72–73. *see also* frictional forces  
 fundamental, 461  
 grand-unified theories and, 461  
 Kepler's laws of planetary motion and, 89–91  
 magnetic, 285–302  
 momentum and, 125–140  
 moving a chair and, 71–72  
 net, 63  
 Newton's law of universal gravitation and, 17, 61–62, 91–94  
 Newton's laws of motion and, 62–74  
 normal, 69–71, 85–87, 97, 105, 131, 171, 356  
 oscillation and, 115–118  
 pressure, 171. *see also* pressure  
 restoring, 117–118  
 skydiving and, 72–73  
 tension, 81–84, 104, 111, 159, 162, 275, 310, 314–315  
 thermodynamics and, 204–205  
 torque, 149–152, 246, 287, 291–293  
 weight and, 66–67  
 work and, 105
- fossil fuels, 3, 273, 310, 423  
 alternatives to, 227–228, 229, 386–387  
 ending dependence on, 169  
 greenhouse effect and, 209  
 heating homes and, 206  
 thermal power plants and, 225–228
- Fourier analysis, 314
- fourth harmonic wave, 324
- frame of reference  
 changes in, 449  
 defined, 435  
 inertial, 438, 441  
 luminiferous ether as, 439  
 principle of equivalence and, 449–450  
 relativity and, 435–453  
 speed of light and, 438–442  
 twin paradox, 446–447, 451
- Franklin, Benjamin, 241–242
- free fall, 17, 31, 32, 44, 62, 449
- freezing, 195, 198–199, 208
- frequency  
 beat, 326  
 defined, 117  
 determination of, 314–315  
 Doppler effect, 321, 463  
 fringe patterns and, 341  
 guitar string and, 317–318  
 harmonic analysis and, 314, 323–324  
 pitch and, 317–318, 321, 323, 326  
 Planck's constant and, 398  
 red shift and, 463  
 waves, of, 311, 312–313, 314–315, 317–318
- fretting, 318
- frictional forces, 23, 272, 313, 470  
 centripetal forces and, 84–85  
 conservation an, 110–115  
 energy and, 104, 106–107, 110–115  
 fluids and, 181, 182  
 heat and, 201–203, 230. *see also* heat kinetic, 84–85  
 maximum of, 85  
 momentum and, 130  
 motion and, 63–65, 69, 71–74, 84–87, 153, 156, 159, 162  
 skydiving and, 72–73  
 static, 84–85  
 terminal velocity and, 72–73  
 viscosity and, 182–183
- fringe patterns  
 birefringence and, 348–349  
 diffraction and, 343–346  
 light and, 341
- Frisch, O. R., 419
- fuel cells, 386–387
- Fukushima Daiichi nuclear disaster, 409, 423, 424
- fulcrum, 149–150
- fundamental forces, 461
- fundamental wave, 318, 323–324, 325, 326
- fuses, 277–278
- fusion  
 cold, 428, 468  
 latent heat of, 199

- nuclear, 409, 425–428, 448, 468  
 power generation from, 427–428  
 weapons and, 425–428
- ## G
- galaxies, 462–463  
 Galilei, Galileo, 17, 334  
   Aristotle and, 61  
   gravitational acceleration and, 39, 41–42  
   heliocentric view and, 88–89  
   moons of Jupiter and, 462  
   motion and, 60–61, 63  
   phases of Venus and, 89, 462  
   relativity and, 435, 438, 441  
   water pumps of, 174  
 Galileo Galilei  
   principle of relativity, 438  
 gallium, 465  
 Galvani, Luigi, 237, 264  
 galvanometers, 295  
 gamma rays  
   decay and, 413–415, 417  
   electromagnetic spectrum and, 335  
   health hazards, 416  
   magnetic field and, 394  
   penetrating power of, 410  
   radioactive decay, 413, 415  
   role in neutron discovery, 410  
   Rutherford and, 396  
 gases  
   atmospheric pressure and, 174–176, 177  
   Bernoulli's principle and, 184–186  
   compressibility and, 176–177, 187, 203–204  
   entropy and, 224–225  
   equation of state and, 205, 206  
   first law of thermodynamics and, 203–206  
   ideal, 204–205, 221  
   ionized, 245  
   noble, 403  
   speed of sound and, 319–320  
   springy nature of, 177  
 Geiger, Hans, 395, 396  
 General Electric, 424  
 general theory of relativity  
   black holes, 452  
   gravitational red shift, 451, 463  
   gravity and, 461  
   gravity waves, 452  
   principle of equivalence, 449–450  
   space and time effects, 451–452  
 generators, 299–301, 311  
 geocentric model, 88–89, 325  
 geometric optics, 355  
 geothermal energy, 227  
 germanium, 465, 468, 469  
 Gilbert, William, 287, 288  
 global warming, 3, 169, 209  
   fossil fuels and, 3  
   greenhouse gases and, 3, 209, 245  
 Goddard Space Flight Center, 458  
 grand unified theories (GUTs), 461  
 graphite, as nuclear moderator, 421  
 graphs  
   absolute zero and, 195–196  
   acceleration and, 28–29  
   distance traveled and, 29  
   information from, 27–28  
   motion and, 27–29  
   slope and, 28  
   uniform acceleration and, 31–32  
   velocity, 28–29  
   waves and, 313–314  
 gratings, 343–346  
 gravitational acceleration  
   ball dropped in elevator, 449  
   Einstein's general theory of relativity, 449–451  
   falling objects and, 39–48  
   mass and, 66–67  
   measurement of, 39–41  
   Newton's law of universal gravitation and, 17, 61–62, 91–94  
   projectiles and, 48–50  
   throwing a ball upward and, 46–48  
   weight and, 66–67, 93–94  
 gravitational potential energy, 108  
 gravitational red shift, 451, 463  
 gravitational torque, 160  
 gravity  
   Aristotle and, 41–42  
   Big Bang theory and, 464  
   center of, 151–152  
   conservative forces and, 110  
   Coulomb's law and, 247–248  
   falling objects and, 39–48  
   free fall and, 17, 31, 32, 44, 62, 449  
   Galileo and, 39, 41–42  
   impact on light beam, 450–451  
   law of universal gravitation and, 17, 61–62, 66–67, 91–94  
   light and, 450–451  
   principle of equivalence and, 449–450  
   projectile motion and, 48–50  
   weight and, 66–67  
 gravity waves, 452  
 Greek symbols, 147  
 greenhouse, 209  
 greenhouse effect, 209  
 greenhouse gases  
   carbon dioxide, 209, 245  
   carbon dioxide and, 3  
   electrostatic precipitators and, 245  
   global warming and, 3, 209  
 guitar string, 317–318
- ## H
- hadrons, 460  
 Hahn, Otto, 418  
 hair, 239  
 half-life, 415–416, 421  
 halogens, 388  
 Hanford, Washington nuclear reactors, 421, 425  
 harmonic analysis  
   antinodes and, 322, 323  
   Fourier and, 314  
   music and, 314, 322–326  
   nodes and, 322, 323  
   tone quality and, 323  
 harmonic motion, 115–118  
 harmonic waves  
   fifth harmonic and, 318, 324  
   first harmonic and, 317, 323  
   Fourier analysis and, 314  
   fourth harmonic and, 324  
   fundamental and, 317, 323–324, 325, 326  
   guitar string and, 317–318, 322–326  
   music and, 320–321, 322–326  
   pitch and, 317–318  
   second harmonic and, 318, 323–325  
   sinusoidal form and, 313–314  
   third harmonic and, 323–325  
 harmony, 325–326  
 health hazards, radioactivity, 416  
 heat  
   bimetallic strips and, 275  
   blackbody, 398  
   Clausius statement and, 224  
   collisions and, 134  
   conduction and, 206–207  
   convection and, 207–208  
   defined, 197  
   efficiency of, 217  
   entropy and, 216, 224–225  
   flow of, 206–207  
   freezing and, 195, 198–199, 208  
   gas compression and, 203–204  
   high-grade, 228  
   infiltration and, 208  
   internal energy and, 217, 219, 223, 226, 229  
   latent, 199  
   low-grade, 228  
   melting and, 198–199, 202, 226  
   perpetual motion and, 228–229  
   radiation and, 208  
   specific heat capacity and, 196–199  
   steam engines and, 169, 202, 216, 220  
   temperature and, 198  
 heat engines, 205, 206  
   automobiles and, 216–217  
   Carnot engines and, 220–222

- heat engines—*Cont.*  
 efficiency of, 217  
 first law of thermodynamics and,  
 217–219, 228–229  
 net heat and, 217, 219  
 perpetual motion and, 228–230  
 reversibility and, 220–222  
 second law of thermodynamics and,  
 216, 220–222  
 steam engines and, 169, 202,  
 216, 220  
 waste heat and, 217, 226
- heat packs, 200
- heat pumps, 222–223
- heat reservoir, 217
- heliocentric model, 61, 88–89
- heliocentric view, 462
- helium  
 protons and neutrons, 411  
 radioactive decay, 412
- Henry, Joseph, 297, 299
- Hertz, Heinrich, 333
- hertz (Hz) unit, 117
- Higgs boson, 460–461
- high-energy physics  
 Big Bang theory and, 464  
 cloud chambers and, 458  
 electroweak force and, 461  
 elementary particles and, 458–461  
 fundamental forces and, 461  
 grand-unified theories and, 461  
 kinetic energy and, 459  
 particle accelerators and, 458–460  
 scattering experiments and,  
 458–461, 472  
 strong nuclear interaction and, 461  
 unified field theory and, 248,  
 461, 464
- high-grade heat, 228
- high-temperature superconductors,  
 469–470
- Hittorf, Johann, 389
- holes, semiconductors, 465–466
- holograms, 471–472
- Hooke, Robert, 109
- Hooke's Law, 109
- household circuits, 276–278
- Hubble, Edwin, 463
- Hubble law, 463
- Hubble Space Telescope, 458, 462
- human eye  
 cones and, 336–337  
 cornea and, 336, 370, 371, 372  
 eyeglasses and, 370–371  
 image formation and, 369–371  
 laser refractive surgery, 372  
 mechanisms of, 369–370  
 retina and, 336, 369–375  
 rods and, 336–337
- Humason, Milton, 463
- hydraulic jacks, 172–173
- hydrogen  
 nuclear fusion fuel, 426–427  
 protons and neutrons, 412  
 hydrogen bombs, 426–427  
 hydrogen economy, 386–387  
 hydrogen spectrum, 396–398  
 hypothesis, 4–5
- ## I
- ideal gases, 204–205, 221
- image formation  
 binoculars and, 375  
 curved mirrors and, 366–369  
 dispersion and, 361–362  
 focal length and, 362–366, 371, 374  
 focal point and, 363–367, 369, 371  
 human eye and, 369–371  
 inverted image and, 364  
 lenses and, 362–366  
 light rays and, 355–356  
 magnification and, 364, 368  
 microscopes and, 371–373  
 plane mirrors and, 357  
 prisms and, 358, 361–362, 374  
 rainbows and, 362–363  
 ray-tracing and, 364, 366–368  
 real image and, 364  
 reflection and, 355–357, 360–361  
 refraction and, 358–362  
 surface normal and, 356, 357, 359,  
 361–362, 366  
 telescopes and, 373–374  
 underwater objects and, 359–360  
 virtual image and, 357  
 wavefronts and, 321, 355–356
- implosion, 426
- impulse  
 collisions and, 138  
 defined, 126  
 momentum and, 125–140  
 Newton's second law of motion and,  
 126–127  
 Newton's third law of motion and, 128
- impulse-momentum principle, 127–128
- index of refraction, 342, 358–362, 372
- indium, 465
- induction, 243–244  
 electromagnetic, 295–299  
 Faraday's law and, 296, 299–300  
 Lenz's law and, 296–297  
 primary coil and, 295, 300–301  
 secondary coil and, 295, 300–301  
 self, 297, 300–301  
 transformers and, 300–301
- inductors, 297
- inelastic collisions, 133–135
- inertia, 297  
 inertial frame of reference, 438, 441  
 moment of, 153  
 Newton's laws of motion and, 64–66
- relativity and, 438, 439, 441, 445–446,  
 449–452  
 rotational, 152–155
- inertial frame of reference, 438, 439, 441,  
 445–446, 449–452
- infiltration, 208
- infrared light, 335
- instantaneous acceleration, 25–26
- instantaneous speed, 21
- instantaneous velocity, 24, 28
- insulators, 242–244, 263  
 material properties, 465
- integrated circuits (ICs), 467–468
- interference  
 diffraction and, 343–346  
 fringe patterns and, 341  
 light wave, 439–440  
 thin-film, 341–342  
 waves and, 313, 315–318, 338–342  
 Young's double-slit experiment and,  
 340–341
- interferometers, 439–440
- International Business Machines  
 (IBM), 467
- intervals, 324–325
- ionization, 255, 414
- ionized gas, 245
- iron, protons and neutrons, 411
- isobaric processes, 205, 206
- isothermal processes, 205
- isotopes, 411–412, 423, 464  
 atomic number and, 412–413, 415,  
 421, 426  
 fission and, 418–420  
 mass variations and, 411–412  
 nucleus and, 409–429  
 properties of, 411–412  
 radioactive decay and, 412–417
- ## J
- James Webb Space Telescope, 458
- Japan  
 Fukushima Daiichi power plant, 424  
 Hiroshima and Nagasaki, 426
- Joule, James Prescott, 169, 201–202, 221
- junctions, 465
- Jupiter, 89, 184, 462
- ## K
- kaons, 460
- Kelvin temperature scale, 196, 221
- Kepler, Johannes, 89
- Kepler's laws of planetary motion, 89–91,  
 95, 157
- kilocalories, 203
- kinetic energy, 103, 459  
 atomic structure and, 399, 417–418,  
 421, 426  
 Bernoulli's principle and, 184–186

Bohr model and, 399  
 collisions and, 133–139  
 conduction and, 207  
 conservation of, 110–115, 135, 138  
 defining, 106–107  
 electric energy and, 252–253, 272–274  
 entropy and, 224–225  
 fluids and, 184–186  
 fusion and, 426–427  
 harmonic motion and, 115–118  
 heat and, 202–203, 224–225, 230  
 magnetism and, 291  
 mass-energy equivalence and, 447–448  
 momentum and, 127, 133–135  
 Newton's second law of motion and, 106  
 particle accelerators and, 459  
 pendulums and, 110–111  
 pole vaulting and, 114  
 relativity and, 447–448  
 rest energy, 447–448  
 rest energy and, 448  
 stopping distance for moving car and, 107  
 waves and, 309, 310  
 work and, 106–107  
 kinetic force of friction, 84–85  
 krypton, nuclear fission, 419

## L

laminar flow, 183–184  
 Large Hadron Collider (Switzerland), 459, 460  
 laser refractive surgery, 372  
 lasers, 9, 345, 346, 372  
   holograms, 471–472  
 LASIK (laser assisted in situ keratomileusis), 372  
 latent heat of fusion, 199  
 latent heat of vaporization, 199  
 Lavoisier, Antoine, 384  
 law of reflection, 356, 368  
 law of refraction, 358–359  
 L cones, 337  
 lead, radioactive decay, 413  
 Leavitt, Henrietta, 463  
 length-contraction formula, 444–445  
 lenses  
   focal length and, 363–364  
   focal point and, 363–364  
   human eye and, 336  
   image formation and, 362–366  
   inverted image and, 364  
   magnification and, 364  
   negative, 365–366, 370–371  
   positive, 362–364, 365–366, 373–374  
   ray-tracing and, 364, 365–366  
   real image and, 364

Lenz, Heinrich, 296  
 Lenz's law, 296–297  
 leptons, 459–460  
 lever arm  
   magnetism and, 292  
   torque and, 150–151, 153, 155, 157–158, 162, 292  
 light  
   antireflection coatings and, 343  
   apertures and, 345  
   bend, 361  
   binoculars and, 374–375  
   blackbody, 398  
   blue sky and, 336, 339  
   color and, 336–338  
   diffraction and, 343–346  
   diffusion and, 338  
   dispersion and, 361–362  
   as electromagnetic waves, 332–350  
   Fizeau wheel and, 334  
   focal length and, 362–366, 371, 374  
   focal point and, 363–367, 369, 371  
   fringe patterns and, 341, 343–346  
   gratings and, 343–346  
   gravity and, 450–451  
   holograms and, 471–472  
   image formation and, 355–376  
   infrared, 335  
   interference and, 338–342  
   lenses and, 336, 362–366, 370–371  
   microscopes and, 371–373  
   mirrors and, 357, 366–368  
   phase and, 333, 340–342  
   photons and, 307  
   polarized, 346–349  
   prisms and, 307, 336, 338, 346, 358, 361–362, 374  
   quantization of energy of, 398  
   rainbows and, 2, 4–6, 9, 13, 336, 355, 362–363  
   ray-tracing and, 364, 366–368  
   reflection and, 332, 334, 335, 337–338, 341–342, 346, 348, 349, 355–357, 360–361  
   refraction and, 307, 332, 342, 348–349, 358–362  
   scattered, 337, 339, 348, 355–357, 359  
   selective absorption and, 337  
   soap film and, 332  
   of speed, 438–442  
   speed of, 265, 312, 333–334, 355, 358–359, 362  
   stroboscopes and, 39–40  
   surface normal and, 356, 357, 359, 361–362, 366  
   telescopes and, 373–374  
   thin films and, 341–342  
   ultraviolet, 335  
   underwater objects and, 359–360  
   unpolarized, 347

wavefronts and, 321, 355–356  
 Young's double-slit experiment and, 340–341  
 lightbulbs, 261–262  
 light clocks, 442–443  
 lightning, 254–255  
 light waves  
   impact of gravitational field, 452  
   interference, 439–440  
   speed of light, 438–442  
 linear momentum, 126  
 linear motion, 146, 147–148, 152, 153, 155  
 liquid crystals, 470–471  
 liquids  
   Bernoulli's principle and, 184–186  
   buoyancy and, 178–180  
   flow and, 181–184  
   viscosity and, 182–183  
 Little Boy, 426  
 longitudinal waves, 311–312, 319  
 low-grade heat, 228  
 luminiferous ether  
   Michelson-Morley experiment, 439–440  
   nature of, 438–439  
   as universal frame of reference, 439  
 luminosity, 463

## M

magnetic dipole, 287  
 magnetic effect, 237  
   Ampère and, 295  
   compasses and, 288–289  
   direction of, 290–291  
   Earth as magnet and, 287–288  
   electric currents and, 288–295  
   electromagnetic induction and, 295–299  
   Faraday's law and, 294, 296, 299–300  
   ferromagnetic materials and, 293  
   field lines and, 287–288, 291, 299  
   Lenz's law and, 296–297  
   Oersted and, 288–289, 295  
   poles of, 285–286  
   torque and, 287, 291–293  
 magnetic fields  
   current loops and, 291–293  
   dipole and, 287  
   Earth's, 287–288  
   electromagnetic waves and, 332–333  
   generators and, 299–300  
   induction and, 295–299  
   particle accelerators, 459  
   polarized light and, 346–349  
   transformers and, 300–301  
 magnetic flux  
   induction and, 296–297  
   transformers and, 299–300, 300–301



- magnetic force  
 current-carrying wire and, 289–290  
 direction of, 290–291  
 moving charge and, 290–291
- magnetic monopoles, 287
- magnetic poles, 285–286
- magnetic resonance imaging (MRI)  
 devices, 470
- magnetic torque, 287, 291–293
- magnetism  
 Faraday's law and, 294, 296, 299–300  
 generators and, 299–300, 311  
 transformers and, 300–301
- magnetite, 285
- magnification, 364–365, 368
- magnitude, 23
- Manhattan Project, 414, 420, 426
- Mariotte, Edme, 177
- Mars, 87–89
- Marsden, Ernest, 395
- mass  
 atomic, 385, 387, 409–412, 417–418  
 center of gravity and, 151–152  
 comparisons of, 66  
 conservation of, 384  
 defined, 64  
 density and, 174  
 Einstein's mass-energy equation and,  
 417–418, 420, 447–448  
 of electron, 410  
 electron, of, 392  
 gravitational acceleration and, 66–67  
 inertia and, 64–66, 152–155, 297,  
 438–442, 445–446, 449–452  
 isotopes and, 411–412  
 momentum and, 125–140  
 of neutron, 410  
 Newton's laws of motion and, 64,  
 66–67  
 oscillation and, 115–118  
 of protons, 409–410  
 weight and, 66–67
- mass-energy equivalence  
 nuclear fission, 420  
 nuclear fusion, 426–427  
 nuclear reactions, 417–418  
 rest energy, 447–448
- mass numbers, 412–413
- materials science, 468
- mathematics. *see also* equations  
 plane geometry, 138  
 proportion, 10  
 role of measurement in, 9–12. *see also*  
 measurement
- Maxwell, James Clerk, 237  
 electric field lines and, 249  
 electromagnetic waves and, 285, 307,  
 332–335  
 electroweak force and, 461  
 Faraday's law and, 295, 332
- model of luminiferous ether, 438–439  
 speed of light and, 333–334
- Maxwell's theory of electromagnetism  
 luminiferous ether and, 438–439  
 unified field theory, 461
- M cones, 337
- 100-m dash, 30
- measurement, 9–12  
 atmospheric pressure, 174–176  
 distance, 444–445  
 effective current/voltage, 274–276  
 electrostatic force, 240–241,  
 246–247  
 Heisenberg uncertainty principle  
 and, 402  
 Hubble law and, 463–464  
 index of refraction, 342, 358–362, 372  
 luminosity, 463  
 pressure, 174  
 rotational motion, 147  
 speed of light, 333–334  
 stroboscopes, 39–40  
 temperature, 193–196  
 time dilation and, 442–443
- mechanical advantage, 104
- Meissner effect, 469
- Meitner, Lise, 419
- melting, 198–199, 202, 226
- Mendeleev, Dmitri, 388
- mercury (element)  
 pressure measurement and, 174–178  
 temperature measurement and, 194
- merry-go-rounds, 146, 147, 148, 149,  
 152–155, 158
- mesons, 459–460
- metric system, 10
- Michelson, Albert, 439–440
- Michelson interferometer, 439–440
- Michelson-Morley experiment,  
 439–440
- microelectronics  
 computers, 458, 467–468  
 integrated circuits, 467–468  
 semiconductors, 465, 467–468  
 solid-state, 464–468  
 transistors, 465–467
- microscopes, 371–373
- microwave ovens, 464
- microwaves, 335
- Milky Way, 462–463
- millirems (mrems), 416
- mirrors, 357  
 concave, 366–368  
 convex, 368–369
- moderators, nuclear, 421–422, 423
- molecules, 112, 335  
 atoms and, 385  
 blue sky and, 339  
 electrostatic phenomena and, 244  
 gas, 94, 176
- heat and, 202, 204–205, 225  
 polarized light and, 347–348  
 quantum mechanics and, 7  
 speed of sound and, 319–322
- moment of inertia, 152–155
- momentum  
 angular. *see* angular momentum  
 bouncing ball and, 125  
 conservation of, 128–130, 139  
 conservation of momentum, 446  
 de Broglie waves and, 400–401  
 defined, 126, 446  
 egg toss and, 129  
 elastic/inelastic collisions and, 133–139  
 impulse-momentum principle and,  
 127–128  
 kinetic energy and, 127, 133–135  
 linear, 126  
 Newton's second law of motion and,  
 126–128  
 Newton's third law of motion and, 128  
 recoil and, 131–133  
 total change in, 128, 130
- moon, 94–97
- Morley, Edward, 439
- motion. *see* motion  
 acceleration and, 19, 24–27. *see also*  
 acceleration  
 Aristotle and, 60–61, 73  
 average speed and, 19–20  
 Bernoulli's principle and, 184–186  
 cause of, 60–61  
 of connected objects, 73–74  
 conservation of energy and, 110–115  
 convection and, 207–208  
 curveballs and, 186  
 Doppler effect and, 321  
 electromagnetic waves and, 332  
 falling objects and, 39–48  
 of fluids, 181–184  
 free fall and, 17, 31, 32, 44, 62  
 frictional forces and, 23, 63–64. *see also*  
 frictional forces  
 Galileo and, 60–61, 63  
 graphing of, 27–29  
 harmonic, 115–118  
 instantaneous speed and, 21  
 kinetic energy and, 103, 106–107. *see*  
*also* kinetic energy  
 linear, 146, 147–148, 152, 153, 155  
 momentum and, 125–140  
 Newton's law of universal gravitation  
 and, 19–20, 61–62, 91–94  
 Newton's laws of, 17, 63, 66, 68–71, 81,  
 86, 92, 106, 127, 130, 152  
 perpetual, 228–230  
 planetary, 87–91  
 projectile, 48–50  
 resistance to, 61  
 retrograde, 88

- rotational, 146–163  
tablecloth trick and, 65  
vectors and, 23–24  
velocity and, 23  
waves and, 309–327. *see also* waves  
work and, 103–106
- muons, 458, 460
- music  
antinodes and, 322, 323  
beat frequency and, 326  
fretting and, 318  
guitar string and, 317–318, 322–326  
harmony and, 325–326  
interval definition and, 324–325  
nodes and, 322, 323  
pitch and, 317–318  
soft-drink bottles and, 320–322  
tuning and, 324–325  
waves and, 320, 322–326
- Mylar, 181
- myopia, 370
- N**
- nanomaterials, 468
- NASA, 386–387
- nearsightedness, 370
- negative charge  
electrostatic force and, 241–242  
Franklin's single-fluid model and, 241–242
- negative lenses, 365–366, 370–371
- negative slope, 28
- negative work, 107
- nerve cells, 264
- net heat, 217, 219
- neurons, 264–265
- neutral charge, 241
- neutrinos, 460
- neutrons  
Big Bang theory and, 464  
Chadwick and, 410  
defined, 410  
discovery, 410–411, 417, 458  
fission and, 418–419  
mass numbers, 412–413  
quarks in, 460–461
- neutron stars, 464
- New System of Chemical Philosophy* (Dalton), 385
- Newton, Isaac, 17  
Aristotle and, 60  
color and, 336, 338  
mass and, 64, 66–67  
planetary motion and, 90–94  
principle of relativity, 438  
relativity and, 435, 438, 441, 445–448
- Newton's first law of motion  
accident analysis and, 86  
centripetal acceleration and, 81  
contained in Newton's second law, 64  
frictional forces and, 63  
inertial frames of reference, 438  
net force and, 64, 66  
statement of, 63
- Newton's law of universal gravitation  
Coulomb's law and, 247–248  
moon and, 95  
planetary motion and, 17, 61, 90–94
- Newton's second law of motion, 17  
acceleration and, 63–64, 67, 70, 81–82, 84–85  
circular motion and, 92  
elevators and, 70  
energy and, 106  
Ferris wheels and, 85, 87  
force definition and, 68, 71  
impulse and, 126–127  
inertial frames of reference, 438  
kinetic energy and, 106  
mass-energy equivalence, 445–446  
momentum and, 125–128  
net force and, 64, 66  
principle of equivalence and, 449–450  
relativity and, 438, 445–448  
rotational inertia and, 152–155  
rotational motion and, 152–155  
speed of waves and, 314  
statement of, 63  
water nozzles and, 185
- Newton's third law of motion  
acceleration and, 69–71  
circular motion and, 84  
force definition and, 63–64, 68–69, 74  
impulse and, 128  
momentum and, 128, 130
- niobium, 469
- nitrogen  
protons and neutrons, 410
- nodes, 317–318, 322, 323
- non-Euclidean geometry, 451
- normal force  
circular motion and, 85–87, 97  
energy and, 105  
fluids and, 171  
momentum and, 131  
Newton's laws of motion and, 69–71  
surface normal and, 356, 357, 359, 361–362, 366
- north-seeking magnetic pole, 285–286
- n-p-n* transistors, 466
- n*-type semiconductors, 465–466
- nuclear energy, 417–418  
from controlled fusion, 427–428  
electroweak force and, 461  
fossil fuels *versus*, 423  
health hazards, 416  
power plants for, 4, 112, 227–228  
strong nuclear interaction and, 461  
weak nuclear force and, 461
- nuclear fission  
discovery, 418–420  
fission bombs, 425  
nuclear reactors, 420–425
- nuclear fusion  
fuel sources, 425  
nature of, 426–427  
power generation, 427–428
- nuclear medicine, 415, 423
- nuclear physics  
fission, 418–420  
isotopes, 411–412  
radioactive decay, 412–417  
reactions, 417–418  
reactors, 420–425  
structure of nucleus, 409–412  
weapons, 425–428
- nuclear pile, 421
- nuclear reactions  
Einstein's mass-energy equation and, 417, 420  
energy and mass in, 417–418  
Fermi and, 418  
nature of, 417  
nuclear fission, 418–420  
nuclear fusion, 425–428
- nuclear reactors, 3–4, 112, 409  
chain reaction, 420–421  
control rods, 421  
coolants, 422  
critical state and, 421, 425  
design features, 422–423  
design features of, 422–423  
environmental issues, 226, 228, 423–425  
moderators, 421, 422, 423  
moderators and, 421  
plutonium production, 421–422, 426  
plutonium production and, 421  
subcritical state and, 421  
supercritical state and, 421, 425–426
- nuclear waste, 419, 423, 425
- nuclear weapons  
critical mass, 425  
hydrogen bombs, 426–427  
plutonium bombs, 425–426  
plutonium production, 421  
thermonuclear bombs, 426  
uranium bombs, 425–426
- nucleons, 412
- nucleus  
alpha radiation, 409–415, 426, 459  
atomic number and, 412–413, 417–419, 421, 426  
beta particles and, 410, 413–415, 460  
de Broglie waves and, 400–401  
discovery, 458  
gamma rays and, 335, 410, 413–415  
neutron discovery, 410–411, 417, 458  
proton and, 386–387, 409–410, 458

**O**

Oak Ridge, Tennessee gas-diffusion plants, 421, 425

object beam, hologram, 472

ocean power plants, 227

ocean waves, 309, 311

ocular, 371

Oersted, Hans Christian, 237, 288, 295

Ohm, Georg, 237, 266

Ohm's law, 266–267, 272, 294

Onnes, Heike Kamerlingh, 468

opera glasses, 374–375

optics

- binoculars and, 374–375
- dispersion and, 361–362
- focal length and, 362–366, 371, 374
- focal point and, 363–367, 369, 371
- human eye and, 369–371
- image formation and, 355–376
- lenses and, 362–366, 370–371
- light rays and, 355–356
- magnification and, 364, 368
- microscopes and, 371–373
- mirrors and, 357, 366–368
- prisms and, 307, 336, 338, 346, 358, 361–362, 374
- rainbows and, 355, 362–363
- ray-tracing and, 364, 366–368
- reflection and, 355–357, 360–361
- refraction and, 358–362
- surface normal and, 356, 357, 359, 361–362, 366
- telescopes and, 373–374
- underwater objects and, 359–360
- wavefronts and, 321, 355–356

oscillation, 115–118

**P**

palladium, 428

parallel circuits, 269–270

partially inelastic collisions, 133–134

particle accelerators, 458–460, 459–460, 464

particle physics, 458–461

- development of, 433

particle waves, 400–403

pascal (Pa), 171

Pascal, Blaise, 172, 176

Pascal's principle, 172, 179

pendulums, 103, 110–111

percentages, expression of fractions, A-3–A-4

period (harmonic motion), 117

periodic table of elements

- chart, A-20

periodic table of the elements, 387–388

periodic waves, 312, 314

period of orbit, 90

period of wave, 312

perpetual-motion machine of the first kind, 228–229

perpetual-motion machine of the second kind, 229–230

phase, 316

- diffraction and, 343–346
- waves and, 316–317, 322, 326, 333, 338–342

phases of the moon, 94–95, 97

photographic plates, holograms, 472

photons

- de Broglie waves and, 400–401
- waves and, 307

physics. *see also* everyday phenomena

- Big Bang theory and, 464
- classical, 8, 435–438, 447
- condensed-matter, 8–9, 403, 433, 468
- cosmology and, 461–464
- defining, 7–8
- energy and, 3–4
- high-energy, 458–473
- major subfields of, 8–9
- modern, 8, 433, 452, 458
- music, of, 322–326
- nuclear, 8–9, 14, 161, 309, 381, 393
- quantum mechanics and, 7, 17, 62, 307, 381, 398, 400–403, 402
- role of measurement in, 7–12
- scope of, 6–9
- unified field theory and, 248

pions, 458

pistons, 203–204

pitch, 317–318, 321, 322–323, 326

pith balls, 239–240

Planck's constant, 398–399, 400–402

plane geometry, 138

planetary motion

- artificial satellites and, 95, 97
- Copernicus and, 17, 61, 88–89
- early models of, 87–89
- eclipses and, 94
- ellipses and, 89–90
- epicycles and, 88, 89
- fixed stars and, 87
- geocentric view of, 88–89, 90, 325
- heliocentric view, 462
- heliocentric view and, 17, 61, 88–89, 90
- Kepler's laws of, 89–91, 95
- law of universal gravitation and, 89–94
- Newton and, 91–94
- period of orbit and, 90–91
- phases of the moon and, 94–95
- phases of Venus and, 89
- Ptolemy and, 88
- retrograde motion and, 88–89
- synchronous orbit and, 95

plastic crystals, 471

Plato, 88

plutonium, 428

- environmental issues and, 423
- nuclear reactor production, 414, 421
- nuclear weapons and, 425–426
- production of, 421

plutonium, bombs, 426

*p-n-p* transistors, 466

poison, 423

polarized light, 346–349

polarized material, 244

pole vaulting, 114

polonium

- radioactive decay, 415–416

polymers, 347

positive charge, 412

- electrostatic force and, 241–242
- Franklin's single-fluid model and, 241–242

positive lenses, 362–364, 366, 370, 373

positrons, 417, 458, 460

potential energy, 310

- changed position and, 108
- conservation of energy and, 110–115
- conservative forces and, 110
- defining, 108
- elastic, 109–110
- electric circuits and, 262, 263, 272–274
- electrostatic phenomena and, 251–254
- fluids and, 184–185
- gravitational, 108
- harmonic motion and, 115–118
- heat and, 201–203, 230
- pendulums and, 103, 110–111
- pole vaulting and, 114
- work and, 108–110

power

- electric energy and, 272–274
- Ohm's law and, 272
- thermal power plants and, 225–228
- transformers and, 301
- work and, 105–106

powers of ten, 12

pressure

- absolute zero and, 195–196
- Archimedes' principle and, 178–181
- area and, 171–172
- atmospheric, 173–178
- Bernoulli's principle and, 184–186
- blood, 175
- Boyle's law and, 177
- buoyancy and, 178–180
- defined, 171–172
- density and, 174
- flow and, 181–184
- gas compression and, 203–204
- hydraulic jacks and, 172–173
- ideal gas and, 204–205
- liquids and, 179
- measurement of, 174–176
- Pascal's principle and, 172, 179

sound waves and, 319–322  
 vacuums and, 174–176  
 variance in pipes/hoses and, 185  
 volume and, 177  
 water nozzles and, 185  
 primary coil, 295, 300–301  
 principal quantum number, 402–403  
*Principia* (Newton), 17, 62  
 principle of equivalence, 449–450  
 principle of relativity, 437–438  
 principle of superposition, 316, 318  
 prisms, 307, 336, 338, 346  
   bending light and, 361–362  
   dispersion and, 361–362  
   image formation and, 358, 361–362,  
     374, 396–397  
 projectile motion  
   basketballs, 52–53  
   bullets, 50–51  
   footballs, 51–52  
   hitting target and, 50–54  
   initial velocity and, 49–50  
   maximum distance, 52–54  
   Newton's law of universal gravitation  
     and, 91–92  
   time of flight, 49–50  
   trajectory of, 48–49  
   vectors and, 48–54  
 proper time, 443  
 proportion, 10  
 proton exchange membrane (PEM), 386  
 protons  
   atomic structure and, 386–387  
   Big Bang theory and, 464  
   defined, 409–410  
   discovery, 409–410, 458  
   mass numbers, 412–413  
   mass of, 409–410  
   nuclear energy and, 417–420  
   nucleus and, 409–412, 417–420  
   positive charge, 412  
   *p*-type semiconductors, 465–466  
   quarks in, 460  
   radioactive decay and, 412–413  
   Rutherford and, 409–410  
 Ptolemy, 88  
*p*-type semiconductors, 465–466  
 Pythagorean theorem, 138

## Q

quantization, 398  
 quantum chromodynamics, 460  
 quantum electrodynamics, 460  
 quantum mechanics, 7, 17, 62, 433  
   atomic structure and, 381  
   blackbody radiation and, 398  
   Bohr model and, 401–402  
   chemistry and, 402–403  
   Heisenberg uncertainty principle  
     and, 402

light energy and, 398  
 nucleus and, 410  
 particle waves and, 400–403  
 periodic table and, 402–403  
 photoelectric effect and, 400  
 photons and, 307, 398, 400–401, 402  
 Planck's constant and, 398–399,  
   400–402  
 quantum numbers, 402  
 quarks and, 460–461  
 relativity and, 460  
 superconductivity and, 469  
 quarks, 460–461, 464  
   baryons, 460  
   Big Bang theory and, 464  
   bottom, 460  
   charmed, 460  
   down, 460  
   electroweak force and, 461  
   fundamental forces and, 461  
   hadrons, 460  
   kaons, 460  
   leptons, 459–460  
   mesons, 460  
   pions, 458–459, 463  
   positrons, 413, 417, 458, 460  
   protons, 458–460  
   strange, 460  
   top, 460  
   unified field theory and, 461, 464  
   up, 460  
   weak nuclear force and, 461  
 quartz, 349

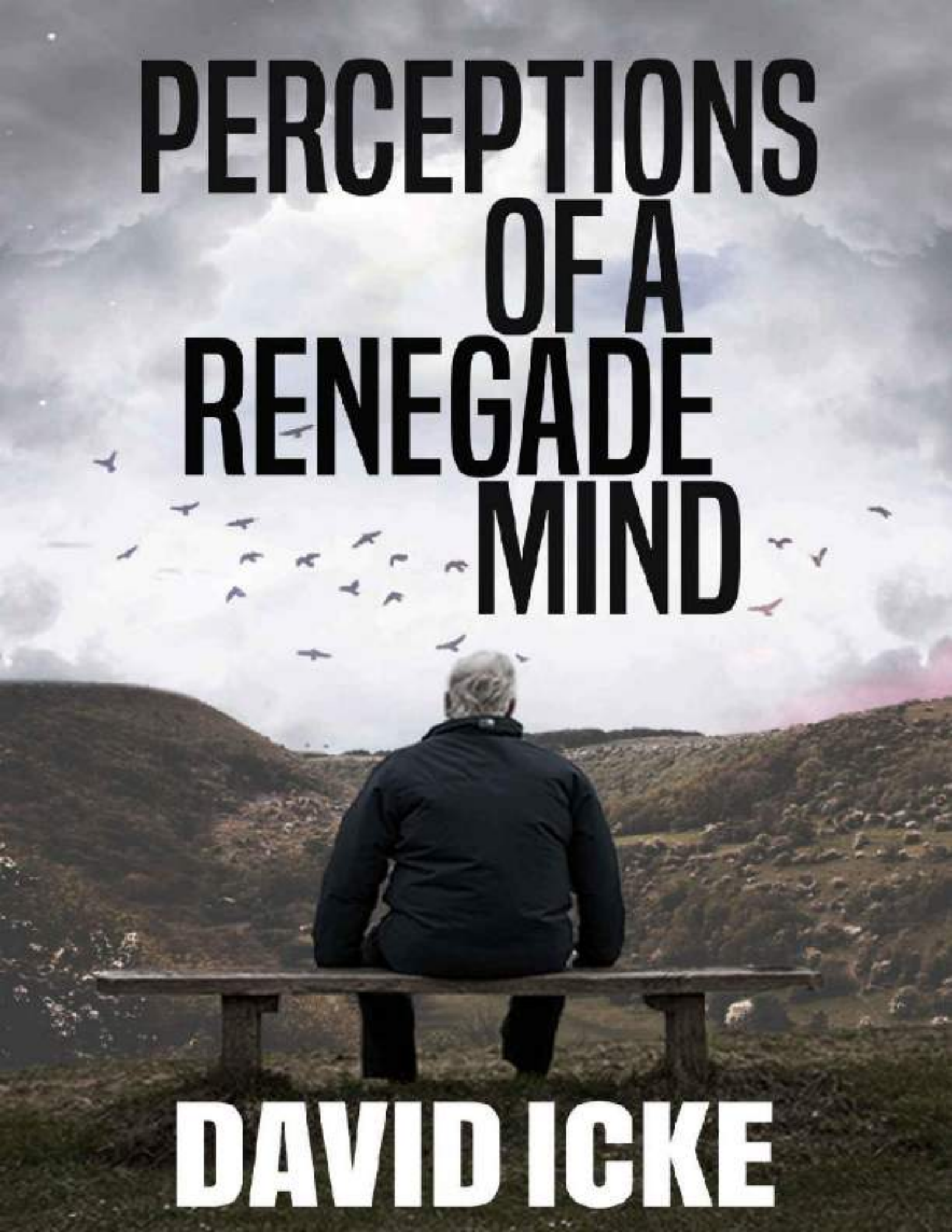
## R

radians, 146–147, 149  
 radiation, 208, 227  
   alpha, 394–396  
   background sources, 416  
   beta, 394, 396  
   blackbody, 398  
   cathode rays and, 389–393, 396  
   gamma, 335, 394, 396  
   natural radioactivity and, 392, 393,  
     394, 396  
   X-rays and, 332, 334–335, 383,  
     392–393, 401  
 radioactive decay  
   alpha particle, 412–413  
   beta decay, 413–415  
   exponential decay, 415  
   gamma decay, 413–415  
   half-life and, 415–416, 421, 423  
   health hazards of, 416  
   rate of decay, 415–416  
 radioactive waste, 419, 423, 425  
 radioactivity, 392  
   atomic nucleus and, 393–396  
   Curies and, 394  
   discovery of, 393  
   health hazards, 416  
   Rutherford and, 394–396  
   types of, 394  
 radio waves, 335  
 radium, 394, 412–413  
   radioactive decay, 412–413  
 radius, 91  
 radon  
   health hazards, 416  
   radioactive decay, 413, 415  
 rainbows, 2, 4–6, 9, 13  
   color and, 336  
   empirical laws and, 5  
   formation of, 362–363  
   reflection and, 355, 362–363  
   refraction and, 355, 362–363  
   secondary, 363  
 Rayleigh scattering, 339  
 ray tracing, 364, 366–368  
 reaction time, 44–45  
 real image, 364  
 recipe, scaling, 11  
 recoil, 131–133  
 rectification, 311  
 red shift, 463  
 reference beam, hologram, 472  
 reflection  
   antireflection coatings and, 343  
   color and, 336–338  
   double, 363  
   image formation and, 355–357  
   law of, 356, 368  
   light and, 332, 334, 335, 337–338,  
     341–342, 346, 348, 349  
   rainbows and, 362–363  
   scattering and, 355  
   surface normal and, 356, 357, 359,  
     361–362, 366  
   total internal, 360–361  
   wavefronts and, 355–356  
 reflection holograms, 472  
 refraction  
   birefringence and, 348–349  
   dispersion and, 361–362  
   double, 348–349  
   image formation and, 355, 358–362  
   index of, 342, 358–362, 363, 372  
   law of, 358–359  
   light and, 307, 332, 342, 348–349,  
     358–362, 372  
   rainbows and, 362–363  
   total internal reflection and,  
     360–361  
   underwater objects and, 359–360  
 refrigerators, 222–223, 285  
 relative motion, 435–438  
   addition of relative velocities,  
     435–437, 439  
   principle of relativity, 437–438  
   in two dimensions, 437  
 relative velocity, 435–437, 439

- relativity, 417, 433  
 black holes and, 452  
 Einstein's postulates of, 440–442  
 equivalence and, 449–450  
 frame of reference, 435, 438  
 frame of reference and, 435–453  
 Galileo and, 435, 438, 441  
 general theory of, 435  
 gravitational red shift and, 451  
 length contraction and, 444–445  
 light-gravity interaction and, 450–451  
 luminiferous ether and, 438–439  
 mass-energy equivalence and, 447–448  
 Michelson-Morley experiment and, 439–440  
 Newton and, 435, 438, 441, 445–448  
 non-Euclidean geometry and, 452  
 principle of, 437–438  
 quantum mechanics and, 460  
 relative motion, 435–438  
 space-time effects and, 451–452  
 special theory of, 449–452  
 speed of light and, 438–442  
 time dilation and, 442–445  
 twin paradox and, 445, 446–447
- relays, 467
- rem, 416
- resistance  
 electric current and, 266–267  
 Ohm's law and, 266–267, 272  
 parallel circuit and, 269–270  
 series circuit and, 268–269  
 superconductivity, 468–469
- rest energy, 447–448
- rest length, 444
- restoring force, 117–118
- retina, 336, 370–371, 372, 373
- retrograde motion, 88–89
- reversibility, 220–222
- Ritz, 397–398
- rods, 336–337
- roentgen, 416
- Roentgen, Wilhelm, 392
- roentgen equivalent in man (Rem), 416
- Roman Catholic Church, 61, 88
- Roosevelt, Franklin D., 420
- rotating stools, 161
- rotational motion  
 acceleration and, 147–148, 152–155, 158, 159  
 angular momentum and, 13, 155–158  
 balance and, 149–152  
 bicycles and, 158–162  
 center of gravity and, 151–152  
 displacement and, 146–147  
 fulcrum and, 149–152  
 Greek symbol for, 147  
 Kepler's second law and, 157–158  
 lever arm and, 150–151, 153, 155, 157, 159, 160, 162, 292  
 linear motion and, 146, 147–148, 152, 153, 155  
 merry-go-rounds and, 146, 147, 148, 149, 152–155, 158  
 moment of inertia and, 152–155  
 Newton's second law of motion and, 152–155  
 radians and, 146–147, 149  
 spinning tops and, 161  
 torque and, 149–152  
 rotational velocity, 146–147  
 bicycles and, 158, 160  
 conservation of angular momentum and, 155–158  
 constant rotational acceleration and, 148  
 defined, 146  
 electric motors and, 294  
 generators and, 300  
 Greek symbol for, 147  
 inertia and, 153  
 linear velocity and, 149  
 revolutions measurement and, 147  
 yo-yos and, 159
- Rutherford, Ernest, 409  
 atomic structure and, 394
- Rydberg constant, 397, 398
- ## S
- satellites, 95, 97
- scaling recipe, 11
- scattering  
 atomic structure and, 409–412  
 blue sky and, 339  
 high-energy physics, use in, 458–460  
 light, of, 337, 339, 348, 355, 357, 359  
 nucleus structure, discovery of, 409–410, 412
- scientific method, 5–6
- scientific notation, 12, A-4–A-5
- S cones, 337
- Seaborg, Glenn, 414
- seat belts, 86
- secondary coil, 295, 300–301
- second harmonic wave, 318, 323–324
- second law of thermodynamics, 169  
 Carnot engines and, 220–222  
 Clausius statement of, 224  
 efficiency and, 221  
 entropy and, 216, 224–225  
 heat engines and, 219, 220–222  
 Kelvin statement of, 221, 224  
 reversibility and, 220–222  
 statement of, 221
- selective absorption, 337–338
- self-induction, 297, 300–301
- semiconductors, 243  
 integrated circuits, 467–468  
 nature of, 465
- series circuits, 268–269
- Shockley, William, 466–467
- silicon, 465, 467
- simple machines, 103–106
- sinusoidal waves, 313–314, 319
- skydivers, 72–73
- Slinky, 309, 319
- Slipher, Vesto, 463
- slits  
 diffraction and, 343–346  
 Young experiment and, 340–341
- slope, 28
- smoke, 244, 245
- smoke emissions, smoke detectors, 414, 420, 426
- soap films, 341–342
- solar collectors, 209
- solid-state electronics, 464–468
- sound waves  
 antinodes and, 322, 323  
 Doppler effect and, 321  
 harmonic analysis and, 323–324  
 music and, 322–326  
 nature of, 319  
 nodes and, 322, 323  
 pitch and, 317–318, 322–324, 326  
 speed of, 319–320
- south-seeking magnetic pole, 285–287
- spaceships  
 distance measurements varying by observers, 444–445  
 time-dilation formula, 442–445  
 twin paradox, 446–447, 451
- space-time continuum, 452
- special theory of relativity  
 development, 435  
 postulates, 440–442  
 space-time continuum, 452
- specific heat capacity, 196–197
- specular reflection, 338
- speed  
 acceleration and, 24–27, 31–32, 81–87  
 average, 19–21  
 banked curves and, 85  
 of electromagnetic waves, 438–442  
 electromagnetic waves and, 333–334  
 instantaneous, 21  
 length contraction, 444–445  
 of light, 438–442  
 light, of, 265, 312, 333–334, 355, 358–359, 362  
 Newton's first law of motion and, 63, 66  
 principle of equivalence and, 449–450  
 sound, of, 319–320  
 time dilation and, 442–445  
 units of, 20  
 velocity and, 23–24. *see also* velocity  
 waves, of, 312, 314
- spinning tops, 161
- split-ring commutators, 294
- spring constant, 109–110

- springs  
   elastic potential energy and, 109–110  
   harmonic motion and, 115–118  
   Slinky and, 309, 319  
   waves and, 309, 319  
 Sputnik, 95, 97  
 standard model, 458  
 standing waves, 315–318  
 Stanford Linear Accelerator Center (SLAC), California, 459  
 static force of friction, 84–85  
 steam engines, 169, 202, 216, 220  
 Strassmann, Fritz, 418  
 streamlines, 183  
 string theory, 461  
 stroboscopes, 39–40  
 strong nuclear interaction, 461  
 subcritical state, 421  
 subtractive color mixing, 338  
 sun  
   impact of gravitational acceleration on  
     light, 452  
     nuclear fusion, 426  
 sunglasses, 348  
 superconducting supercolliders (SSC), 470  
 superconductors, 468–471  
   high-temperature, 469–470  
   nature of superconductivity, 468–469  
   other exotic materials, 470–471  
 supercritical state, 421, 425  
 superfluids, 469  
 surface normal, 356, 357, 359,  
   361–362, 366  
 synchronous orbit, 95
- T**
- tablecloth trick, 65  
 targets, 50–54  
 Tau particle, 460  
 telescopes, 373–374  
   invention, 462  
 television, 390  
 Teller, Edward, 420  
 temperature  
   absolute, 196, 204, 205, 221  
   absolute zero, 195–196  
   altitude and, 199  
   boiling point, 194, 199  
   caloric model and, 197, 220  
   Celsius scale and, 193, 194–195  
   critical, 469  
   defined, 198  
   Fahrenheit scale and, 193, 194–195  
   freezing point, 194  
   heat and, 198. *see also* heat  
   hot/cold sensations and, 193–194  
   internal energy and, 204–205  
   Kelvin scale and, 196, 221  
   measurement of, 193–196  
   specific heat capacity and, 196–197  
   superconductivity and, 469–470  
   thermal equilibrium and, 194, 198, 199  
   thermostats and, 275  
 tension  
   centripetal acceleration and, 81–84  
   pulley systems and, 104  
   springs and, 275, 310  
   torque and, 159, 162  
   waves and, 314–315, 317–318  
 theory, 5, 62  
 theory of everything, 461  
 thermal chain reaction, 427  
 thermal conductivity, 207  
 thermal equilibrium, 194, 198, 199  
 thermal power plants, 225–228  
 thermodynamics, 169  
   bimetallic strips and, 275  
   conduction and, 206–207  
   convection and, 207–208  
   entropy and, 216, 224–225  
   equation of state and, 205, 206  
   first law of, 201–206  
   freezing and, 195, 198–199, 208  
   gas behavior and, 203–206  
   heat engines and, 216–231  
   infiltration and, 208  
   internal energy and, 110, 202–203,  
     217–219, 223, 226, 229  
   isobaric processes and, 205, 206  
   isothermal processes and, 205  
   Joule and, 201–203, 221  
   Kelvin statement of, 225  
   melting and, 198–199, 202, 226  
   net heat and, 217, 219  
   perpetual motion and, 228–230  
   radiation and, 208  
   reversibility and, 220–222  
   specific heat capacity and, 196–199  
   steam engines and, 169, 202, 216, 220  
   temperature and, 193–196  
   thermal equilibrium and, 194, 198, 199  
   Thompson and, 169, 201  
   zeroth law of, 194  
 thermonuclear bombs, 426–427, 428  
 thermostats, 275  
 thin-film interference, 341–342  
 third harmonic wave, 323–325  
 Thompson, Benjamin (Count Rumford), 201  
 Thompson, William (Lord Kelvin),  
   169, 339  
 Thomson, J. J., 389, 390, 391, 392, 394, 398  
 thorium, half-life, 416  
 thought experiments, 442–445  
 tides, 95, 96  
 time  
   light clocks, 442–443  
   measurement by different observers,  
     442–443  
   time-dilation formula, 442–443  
   time dilation, 442–445  
   time of flight, 49–50  
   toasters, 275, 277  
   tokamak reactor, 427–428  
   Tokyo Electric Power Co., 424  
 torque  
   addition of, 151  
   balance and, 149–150, 151–152  
   center of gravity and, 151–152  
   defined, 150  
   fulcrum and, 149–150  
   gravitational, 160  
   lever arm and, 150–151, 153, 155,  
     157–158, 162, 292  
   magnets and, 287, 291–293  
   net, 151, 152–154, 156  
   Newton's second law of motion and,  
     152–155  
   rotational motion and, 149–152  
   torsion balance and, 246  
 Torricelli, Evangelista, 174  
 total internal reflection, 360–361  
 traffic flow analysis, 22  
 traffic lights, 298  
 trajectories, 48–49  
 transformers, 300–301  
 transistors, 465–467  
 transverse waves, 311–312  
 triangle relationships, 364, 368  
 tritium, 422  
 Truman, Harry S., 426  
 tuning, 324  
 turbines, 225–226, 227–228  
 turbulent flow, 183–184  
 twin paradox, 446–447, 451
- U**
- ultraviolet light, 335  
 unified field theory, 248, 461, 464  
 uniform acceleration, 31–32  
 universal gravitational constant, 93  
 universe  
   beginning of, 463–464  
   expanding, 462–463  
   galaxies, 462–463  
 unpolarized light, 347  
 uranium, 4, 273  
   atomic structure and, 409  
   critical mass and, 425  
   half-life, 416  
   nuclear fission, 418–420, 425  
   nuclear reactions and, 417–420  
   nuclear reactors and, 420–425  
   nuclear weapons and, 425–428  
   protons and neutrons, 411, 412  
   radioactive decay, 419  
   radioactive decay and, 415–416  
   uranium bombs, 425

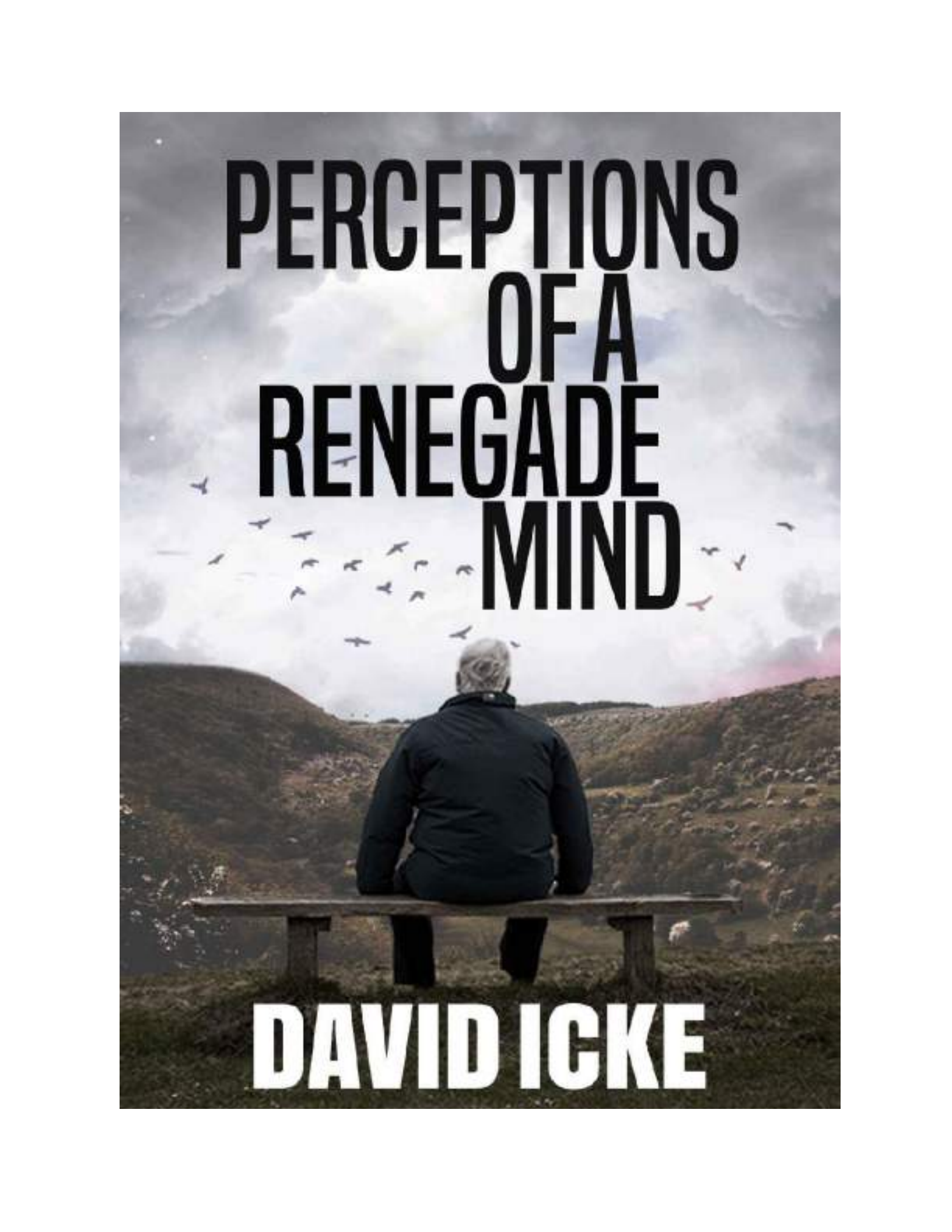
- V**
- vacuum, 186, 358
    - electric field and, 249
    - gravitational acceleration and, 41
    - motion and, 61
    - pumps and, 174–176
    - radiation and, 208
    - speed of electromagnetic waves in, 333–334
  - vectors, 23–24, 26
    - angular momentum and, 158
    - basic concepts, A-7–A-10
    - momentum and, 126
    - polarization and, 349
    - projectile motion and, 48–54
  - vehicle sensors, 298
  - velocity
    - acceleration and, 24–27, 31–32, 39–48, 81–87
    - average, 40–41
    - bouncing ball and, 125–126
    - collisions and, 133–139
    - distance traveled and, 29, 32
    - falling objects and, 39–48
    - free fall and, 17, 31, 32, 44, 62
    - galaxy, 463
    - graphing of, 28–29
    - gravity and, 39–48
    - initial, 49–50
    - instantaneous, 24, 28
    - of light, 439–440
    - magnitude and, 23
    - momentum and, 125–140
    - Newton’s first law of motion and, 63, 64, 66
    - projectile motion and, 48–50
    - relative, 435–437, 439
    - rotational, 146–147, 153, 155–158, 294, 300
    - speed and, 23–24
    - terminal, 72–73
    - time and, 32, 42
    - vectors and, 23–24
    - waves and, 312
  - Venus, 87, 89
  - virtual image, 357
  - viscosity, 182–183
  - Volta, Alessandro, 237, 264, 288
  - voltage
    - alternating, 300
    - back, 294, 297
    - effective, 274–276
    - as electric potential, 251–254
    - electron volts (eV), 459
    - Faraday’s law and, 294, 296, 299–300
    - household wiring and, 276–278
    - induced, 294, 296, 297, 299–300
    - Ohm’s law and, 266–267, 272
    - transformers and, 300–301
  - voltmeters and, 271
  - wave power and, 311
  - voltmeters, 271
  - volume
    - absolute zero and, 195–196
    - atmospheric pressure and, 174, 176–177
    - density and, 174
    - fluids and, 172, 174, 176, 185
    - Pascal’s principle and, 172
  - von Guericke, Otto, 174, 176
- W**
- wafers, silicon, 467
  - waste heat, 217, 226
  - water
    - nuclear reactor coolant, 425
    - nuclear reactor moderator, 422
    - relative velocities, 435–437
  - water nozzles, 185
  - Watts, Robert, 187
  - wavefronts, 321, 355–356
  - wavelength, 312, 314–315
    - color and, 336–338
    - electromagnetic spectrum and, 334–335
    - fringe patterns and, 341
  - waves, 307
    - antinodes and, 317, 318, 322, 323
    - birefringence and, 348–349
    - combination of, 315–316
    - crystals and, 320, 347, 348, 349
    - de Broglie, 400–401
    - Doppler effect and, 321
    - electric power from, 310–311
    - electromagnetic, 332–335
    - extraordinary, 348
    - Fourier analysis and, 314
    - frequency of, 311, 312–313, 314–315, 317–318
    - fundamental and, 318
    - general features of, 309–310
    - graphing of, 313–314
    - gravity, 452
    - guitar string and, 317–318
    - harmonic, 313–314
    - interference and, 315–318, 338–342
    - kinetic energy and, 309, 310
    - light, 332–350. *see also* light
    - longitudinal, 311–312, 319
    - luminiferous ether and, 438–439
    - microwaves and, 335
    - music and, 320, 322–326
    - Newton’s second law of motion and, 314–315
    - nodes and, 317, 318, 323
    - ocean, 309, 310–311
    - periodic, 312, 319
    - phase and, 316, 318, 322, 333, 340–342
    - pitch and, 317–318, 321, 326
  - principle of superposition and, 316, 318
  - pulses and, 309–313
  - radio, 335
  - rope, on a, 313–315
  - sinusoidal, 313, 319
  - Slinky and, 309, 319
  - sound, 319–322
  - speed of, 312, 314
  - standing, 315–318
  - tension and, 314–315
  - transverse, 311–312
  - weak nuclear force, 461
  - Weber, 237
  - weight
    - air columns and, 176–177
    - atomic, 384–387
    - balance and, 149
    - fulcrum and, 149–150
    - gravitational acceleration and, 66–67
    - law of gravitation and, 93–94
    - mass and, 66–67
    - pressure and, 171
    - pulley systems and, 104
    - riding an elevator and, 70
  - whorls, 183–184
  - work
    - conservation of energy and, 110–115
    - defining, 104
    - first law of thermodynamics and, 201–203
    - force and, 105
    - gas compression and, 203–204
    - gravitational potential energy and, 108
    - heat engines and, 216–231
    - kinetic energy and, 106–107
    - mechanical advantage and, 104
    - negative, 107
    - potential energy and, 108–110
    - power and, 105–106
    - simple machines and, 103–106
    - thermodynamics and, 201–203. *see also* thermodynamics
- X**
- X-rays
    - atomic structure and, 383, 392–393, 401
    - discovery of, 392
    - electromagnetic spectrum and, 332, 334–335
    - Roentgen and, 392
- Y**
- Young, Thomas, 338, 342
  - yo-yos, 159
- Z**
- zeroth law of thermodynamics, 194

A person with grey hair, wearing a dark jacket, is seen from behind, sitting on a wooden bench. They are looking out over a vast, open landscape of rolling hills and fields. The sky is filled with many birds in flight, and the overall atmosphere is contemplative and expansive. The text is overlaid on the top half of the image.

# PERCEPTIONS OF A RENEGADE MIND

**DAVID ICKE**



A person with grey hair, wearing a dark jacket, is seen from behind, sitting on a wooden bench. They are looking out over a vast, hilly landscape under a cloudy sky. Numerous birds are flying in the air, scattered across the sky. The overall mood is contemplative and serene.

# PERCEPTIONS OF A RENEGADE MIND

**DAVID ICKE**

**PERCEPTIONS  
OF A  
RENEGADE  
MIND**



ickonic  
publishing

First published in July 2021.

ickonic  
publishing

**New Enterprise House  
St Helens Street  
Derby  
DE1 3GY  
UK**

*email:* [gareth.icke@davidicke.com](mailto:gareth.icke@davidicke.com)

Copyright © 2021 David Icke

No part of this book may be reproduced in any form without permission from the  
Publisher, except for the quotation of brief passages in criticism

*Cover Design:* Gareth Icke  
*Book Design:* Neil Hague

**British Library Cataloguing-in  
Publication Data**  
A catalogue record for this book is  
available from the British Library

eISBN 978-18384153-1-0

**PERCEPTIONS  
OF A  
RENEGADE  
MIND**

A flock of small, dark birds is scattered around the bottom half of the title text, appearing to fly in various directions.

**DAVID ICKE**

**Dedication:**

***To Freeeeedom!***

# **ICKONIC** **THE ALTERNATIVE**

**NEW. DIFFERENT. REVOLUTIONARY**

**HUNDREDS OF CUTTING EDGE DOCUMENTARIES,  
FEATURE FILMS, SERIES & PODCASTS.**

**SIGN UP NOW AT [ICKONIC.COM](http://ICKONIC.COM)**

THE LIFE STORY OF DAVID ICKE  
**RENEGADE**  
THE FEATURE LENGTH FILM



AVAILABLE NOW AT [DAVIDICKE.COM](http://DAVIDICKE.COM)

**Renegade:**

Adjective

'Having rejected tradition: Unconventional.'

**Merriam-Webster Dictionary**



## **Acquiescence to tyranny is the death of the spirit**

You may be 38 years old, as I happen to be. And one day, some great opportunity stands before you and calls you to stand up for some great principle, some great issue, some great cause. And you refuse to do it because you are afraid ... You refuse to do it because you want to live longer ... You're afraid that you will lose your job, or you are afraid that you will be criticised or that you will lose your popularity, or you're afraid that somebody will stab you, or shoot at you or bomb your house; so you refuse to take the stand.

Well, you may go on and live until you are 90, but you're just as dead at 38 as you would be at 90. And the cessation of breathing in your life is but the belated announcement of an earlier death of the spirit.

**Martin Luther King**

**How the few control the many and always have – the many do  
whatever they're told**

'Forward, the Light Brigade!'  
Was there a man dismayed?  
Not though the soldier knew  
Someone had blundered.  
Theirs not to make reply,  
Theirs not to reason why,  
Theirs but to do and die.  
Into the valley of Death  
Rode the six hundred.

Cannon to right of them,  
Cannon to left of them,  
Cannon in front of them  
Volleyed and thundered;  
Stormed at with shot and shell,  
Boldly they rode and well,  
Into the jaws of Death,  
Into the mouth of hell  
Rode the six hundred

**Alfred Lord Tennyson (1809-1892)**

The mist is lifting slowly  
I can see the way ahead  
And I've left behind the empty streets  
That once inspired my life  
And the strength of the emotion  
Is like thunder in the air  
'Cos the promise that we made each other  
Haunts me to the end

The secret of your beauty  
And the mystery of your soul  
I've been searching for in everyone I meet  
And the times I've been mistaken  
It's impossible to say  
And the grass is growing  
Underneath our feet

The words that I remember  
From my childhood still are true  
That there's none so blind  
As those who will not see  
And to those who lack the courage  
And say it's dangerous to try  
Well they just don't know  
That love eternal will not be denied

I know you're out there somewhere  
Somewhere, somewhere  
I know you're out there somewhere

Somewhere you can hear my voice  
I know I'll find you somehow  
Somehow, somehow  
I know I'll find you somehow  
And somehow I'll return again to you

**The Moody Blues**

**Are you a gutless wonder - or a Renegade Mind?**

Monuments put from pen to paper,  
Turns me into a gutless wonder,  
And if you tolerate this,  
Then your children will be next.  
Gravity keeps my head down,  
Or is it maybe shame ...

**Manic Street Preachers**

Rise like lions after slumber  
In unvanquishable number.  
Shake your chains to earth like dew  
Which in sleep have fallen on you.  
Ye are many – they are few.

**Percy Shelley**

# Contents

CHAPTER 1	'I'm thinking' – Oh, but <i>are</i> you?
CHAPTER 2	Renegade perception
CHAPTER 3	The Pushbacker sting
CHAPTER 4	'Covid': The calculated catastrophe
CHAPTER 5	There <i>is no</i> 'virus'
CHAPTER 6	Sequence of deceit
CHAPTER 7	War on your mind
CHAPTER 8	'Reframing' insanity
CHAPTER 9	We must have it? So what is it?
CHAPTER 10	Human 2.0
CHAPTER 11	Who controls the Cult?
CHAPTER 12	Escaping Wetiko
POSTSCRIPT	
APPENDIX	Cowan-Kaufman-Morell Statement on Virus Isolation
BIBLIOGRAPHY	
INDEX	

## CHAPTER ONE

### **I'm thinking' – Oh, but *are* you?**

*Think for yourself and let others enjoy the privilege of doing so too*  
Voltaire

**F**rench-born philosopher, mathematician and scientist René Descartes became famous for his statement in Latin in the 17th century which translates into English as: 'I think, therefore I am.'

On the face of it that is true. Thought reflects perception and perception leads to both behaviour and self-identity. In that sense 'we' are what we think. But who or what is doing the thinking and is thinking the only route to perception? Clearly, as we shall see, 'we' are not always the source of 'our' perception, indeed with regard to humanity as a whole this is rarely the case; and thinking is far from the only means of perception. Thought is the village idiot compared with other expressions of consciousness that we all have the potential to access and tap into. This has to be true when we *are* those other expressions of consciousness which are infinite in nature. We have forgotten this, or, more to the point, been manipulated to forget.

These are not just the esoteric musings of the navel. The whole foundation of human control and oppression is control of perception. Once perception is hijacked then so is behaviour which is dictated by perception. Collective perception becomes collective behaviour and collective behaviour is what we call human society. Perception is all and those behind human control know that which is

why perception is the target 24/7 of the psychopathic manipulators that I call the Global Cult. They know that if they dictate perception they will dictate behaviour and collectively dictate the nature of human society. They are further aware that perception is formed from information received and if they control the circulation of information they will to a vast extent direct human behaviour. Censorship of information and opinion has become globally Nazi-like in recent years and never more blatantly than since the illusory 'virus pandemic' was triggered out of China in 2019 and across the world in 2020. Why have billions submitted to house arrest and accepted fascistic societies in a way they would have never believed possible? Those controlling the information spewing from government, mainstream media and Silicon Valley (all controlled by the same Global Cult networks) told them they were in danger from a 'deadly virus' and only by submitting to house arrest and conceding their most basic of freedoms could they and their families be protected. This monumental and provable lie became the *perception* of the billions and therefore the *behaviour* of the billions. In those few words you have the whole structure and modus operandi of human control. Fear is a perception – False Emotion Appearing Real – and fear is the currency of control. In short ... get them by the balls (or give them the impression that you have) and their hearts and minds will follow. Nothing grips the dangly bits and freezes the rear-end more comprehensively than fear.

## **World number 1**

There are two 'worlds' in what appears to be one 'world' and the prime difference between them is knowledge. First we have the mass of human society in which the population is maintained in coldly-calculated ignorance through control of information and the 'education' (indoctrination) system. That's all you really need to control to enslave billions in a perceptual delusion in which what are perceived to be *their* thoughts and opinions are ever-repeated mantras that the system has been downloading all their lives through 'education', media, science, medicine, politics and academia



in which the personnel and advocates are themselves overwhelmingly the perceptual products of the same repetition. Teachers and academics in general are processed by the same programming machine as everyone else, but unlike the great majority they never leave the 'education' program. It gripped them as students and continues to grip them as programmers of subsequent generations of students. The programmed become the programmers – the programmed programmers. The same can largely be said for scientists, doctors and politicians and not least because as the American writer Upton Sinclair said: 'It is difficult to get a man to understand something when his salary depends upon his not understanding it.' If your career and income depend on thinking the way the system demands then you will – bar a few free-minded exceptions – concede your mind to the Perceptual Mainframe that I call the Postage Stamp Consensus. This is a tiny band of perceived knowledge and possibility 'taught' (downloaded) in the schools and universities, pounded out by the mainstream media and on which all government policy is founded. Try thinking, and especially speaking and acting, outside of the 'box' of consensus and see what that does for your career in the Mainstream Everything which bullies, harasses, intimidates and ridicules the population into compliance. Here we have the simple structure which enslaves most of humanity in a perceptual prison cell for an entire lifetime and I'll go deeper into this process shortly. Most of what humanity is taught as fact is nothing more than programmed belief. American science fiction author Frank Herbert was right when he said: 'Belief can be manipulated. Only knowledge is dangerous.' In the 'Covid' age belief is promoted and knowledge is censored. It was always so, but never to the extreme of today.

## **World number 2**

A 'number 2' is slang for 'doing a poo' and how appropriate that is when this other 'world' is doing just that on humanity every minute of every day. World number 2 is a global network of secret societies and semi-secret groups dictating the direction of society via

governments, corporations and authorities of every kind. I have spent more than 30 years uncovering and exposing this network that I call the Global Cult and knowing its agenda is what has made my books so accurate in predicting current and past events. Secret societies are secret for a reason. They want to keep their hoarded knowledge to themselves and their chosen initiates and to hide it from the population which they seek through ignorance to control and subdue. The whole foundation of the division between World 1 and World 2 is *knowledge*. What number 1 knows number 2 must not. Knowledge they have worked so hard to keep secret includes (a) the agenda to enslave humanity in a centrally-controlled global dictatorship, and (b) the nature of reality and life itself. The latter (b) must be suppressed to allow the former (a) to prevail as I shall be explaining. The way the Cult manipulates and interacts with the population can be likened to a spider's web. The 'spider' sits at the centre in the shadows and imposes its will through the web with each strand represented in World number 2 by a secret society, satanic or semi-secret group, and in World number 1 – the world of the seen – by governments, agencies of government, law enforcement, corporations, the banking system, media conglomerates and Silicon Valley (Fig 1 overleaf). The spider and the web connect and coordinate all these organisations to pursue the same global outcome while the population sees them as individual entities working randomly and independently. At the level of the web governments *are* the banking system *are* the corporations *are* the media *are* Silicon Valley *are* the World Health Organization working from their inner cores as one unit. Apparently unconnected countries, corporations, institutions, organisations and people are on the *same team* pursuing the same global outcome. Strands in the web immediately around the spider are the most secretive and exclusive secret societies and their membership is emphatically restricted to the Cult inner-circle emerging through the generations from particular bloodlines for reasons I will come to. At the core of the core you would get them in a single room. That's how many people are dictating the direction of human society and its transformation

through the 'Covid' hoax and other means. As the web expands out from the spider we meet the secret societies that many people will be aware of – the Freemasons, Knights Templar, Knights of Malta, Opus Dei, the inner sanctum of the Jesuit Order, and such like. Note how many are connected to the Church of Rome and there is a reason for that. The Roman Church was established as a revamp, a rebranding, of the relocated 'Church' of Babylon and the Cult imposing global tyranny today can be tracked back to Babylon and Sumer in what is now Iraq.



**Figure 1:** The global web through which the few control the many. (Image Neil Hague.)

Inner levels of the web operate in the unseen away from the public eye and then we have what I call the cusp organisations located at the point where the hidden meets the seen. They include a series of satellite organisations answering to a secret society founded in London in the late 19th century called the Round Table and among them are the Royal Institute of International Affairs (UK, founded in 1920); Council on Foreign Relations (US, 1921); Bilderberg Group (worldwide, 1954); Trilateral Commission (US/worldwide, 1972); and the Club of Rome (worldwide, 1968) which was created to exploit environmental concerns to justify the centralisation of global power to 'save the planet'. The Club of Rome instigated with others the human-caused climate change hoax which has led to all the 'green

new deals' demanding that very centralisation of control. Cusp organisations, which include endless 'think tanks' all over the world, are designed to coordinate a single global policy between political and business leaders, intelligence personnel, media organisations and anyone who can influence the direction of policy in their own sphere of operation. Major players and regular attenders will know what is happening – or some of it – while others come and go and are kept overwhelmingly in the dark about the big picture. I refer to these cusp groupings as semi-secret in that they can be publicly identified, but what goes on at the inner-core is kept very much 'in house' even from most of their members and participants through a fiercely-imposed system of compartmentalisation. Only let them know what they need to know to serve your interests and no more. The structure of secret societies serves as a perfect example of this principle. Most Freemasons never get higher than the bottom three levels of 'degree' (degree of knowledge) when there are 33 official degrees of the Scottish Rite. Initiates only qualify for the next higher 'compartment' or degree if those at that level choose to allow them. Knowledge can be carefully assigned only to those considered 'safe'. I went to my local Freemason's lodge a few years ago when they were having an 'open day' to show how cuddly they were and when I chatted to some of them I was astonished at how little the rank and file knew even about the most ubiquitous symbols they use. The mushroom technique – keep them in the dark and feed them bullshit – applies to most people in the web as well as the population as a whole. Sub-divisions of the web mirror in theme and structure transnational corporations which have a headquarters somewhere in the world dictating to all their subsidiaries in different countries. Subsidiaries operate in their methodology and branding to the same centrally-dictated plan and policy in pursuit of particular ends. The Cult web functions in the same way. Each country has its own web as a subsidiary of the global one. They consist of networks of secret societies, semi-secret groups and bloodline families and their job is to impose the will of the spider and the global web in their particular country. Subsidiary networks control and manipulate the national political system, finance, corporations, media, medicine, etc. to

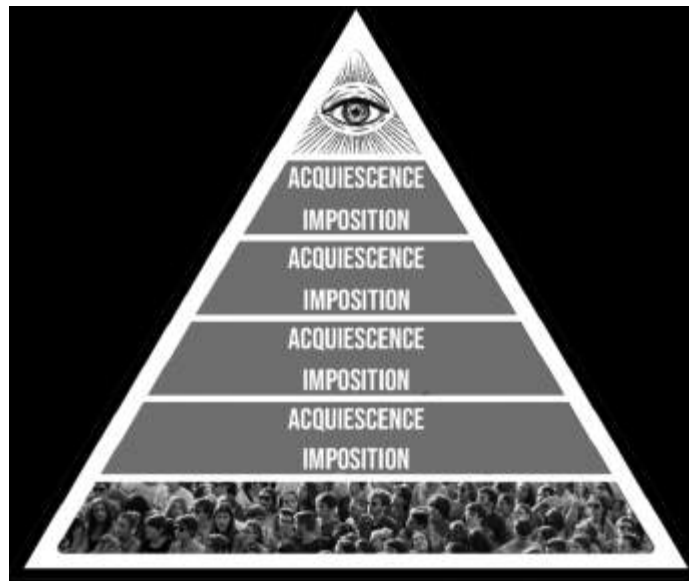
ensure that they follow the globally-dictated Cult agenda. These networks were the means through which the 'Covid' hoax could be played out with almost every country responding in the same way.

## **The 'Yessir' pyramid**

Compartmentalisation is the key to understanding how a tiny few can dictate the lives of billions when combined with a top-down sequence of imposition and acquiescence. The inner core of the Cult sits at the peak of the pyramidal hierarchy of human society (Fig 2 overleaf). It imposes its will – its agenda for the world – on the level immediately below which acquiesces to that imposition. This level then imposes the Cult will on the level below them which acquiesces and imposes on the next level. Very quickly we meet levels in the hierarchy that have no idea there even is a Cult, but the sequence of imposition and acquiescence continues down the pyramid in just the same way. 'I don't know why we are doing this but the order came from "on-high" and so we better just do it.' Alfred Lord Tennyson said of the cannon fodder levels in his poem *The Charge of the Light Brigade*: 'Theirs not to reason why; theirs but to do and die.' The next line says that 'into the valley of death rode the six hundred' and they died because they obeyed without question what their perceived 'superiors' told them to do. In the same way the population capitulated to 'Covid'. The whole hierarchical pyramid functions like this to allow the very few to direct the enormous many.

Eventually imposition-acquiescence-imposition-acquiescence comes down to the mass of the population at the foot of the pyramid. If they acquiesce to those levels of the hierarchy imposing on them (governments/law enforcement/doctors/media) a circuit is completed between the population and the handful of super-psychopaths in the Cult inner core at the top of the pyramid. Without a circuit-breaking refusal to obey, the sequence of imposition and acquiescence allows a staggeringly few people to impose their will upon the entirety of humankind. We are looking at the very sequence that has subjugated billions since the start of 2020. Our freedom has not been taken from us. Humanity has given it

away. Fascists do not impose fascism because there are not enough of them. Fascism is imposed by the population acquiescing to fascism. Put another way allowing their perceptions to be programmed to the extent that leads to the population giving their freedom away by giving their perceptions – their mind – away. If this circuit is not broken by humanity ceasing to cooperate with their own enslavement then nothing can change. For that to happen people have to critically think and see through the lies and window dressing and then summon the backbone to act upon what they see. The Cult spends its days working to stop either happening and its methodology is systematic and highly detailed, but it can be overcome and that is what this book is all about.



**Figure 2:** The simple sequence of imposition and compliance that allows a handful of people at the peak of the pyramid to dictate the lives of billions.

## **The Life Program**

Okay, back to world number 1 or the world of the ‘masses’. Observe the process of what we call ‘life’ and it is a perceptual download from cradle to grave. The Cult has created a global structure in which perception can be programmed and the program continually topped-up with what appears to be constant confirmation that the program is indeed true reality. The important word here is ‘appears’.

This is the structure, the fly-trap, the Postage Stamp Consensus or Perceptual Mainframe, which represents that incredibly narrow band of perceived possibility delivered by the 'education' system, mainstream media, science and medicine. From the earliest age the download begins with parents who have themselves succumbed to the very programming their children are about to go through. Most parents don't do this out of malevolence and mostly it is quite the opposite. They do what they believe is best for their children and that is what the program has told them is best. Within three or four years comes the major transition from parental programming to full-blown state (Cult) programming in school, college and university where perceptually-programmed teachers and academics pass on their programming to the next generations. Teachers who resist are soon marginalised and their careers ended while children who resist are called a problem child for whom Ritalin may need to be prescribed. A few years after entering the 'world' children are under the control of authority figures representing the state telling them when they have to be there, when they can leave and when they can speak, eat, even go to the toilet. This is calculated preparation for a lifetime of obeying authority in all its forms. Reflex-action fear of authority is instilled by authority from the start. Children soon learn the carrot and stick consequences of obeying or defying authority which is underpinned daily for the rest of their life. Fortunately I daydreamed through this crap and never obeyed authority simply because it told me to. This approach to my alleged 'betters' continues to this day. There can be consequences of pursuing open-minded freedom in a world of closed-minded conformity. I spent a lot of time in school corridors after being ejected from the classroom for not taking some of it seriously and now I spend a lot of time being ejected from Facebook, YouTube and Twitter. But I can tell you that being true to yourself and not compromising your self-respect is far more exhilarating than bowing to authority for authority's sake. You don't have to be a sheep to the shepherd (authority) and the sheep dog (fear of not obeying authority).

The perceptual download continues throughout the formative years in school, college and university while script-reading 'teachers', 'academics' 'scientists', 'doctors' and 'journalists' insist that ongoing generations must be as programmed as they are. Accept the program or you will not pass your 'exams' which confirm your 'degree' of programming. It is tragic to think that many parents pressure their offspring to work hard at school to download the program and qualify for the next stage at college and university. The late, great, American comedian George Carlin said: 'Here's a bumper sticker I'd like to see: We are proud parents of a child who has resisted his teachers' attempts to break his spirit and bend him to the will of his corporate masters.' Well, the best of luck finding many of those, George. Then comes the moment to leave the formal programming years in academia and enter the 'adult' world of work. There you meet others in your chosen or prescribed arena who went through the same Postage Stamp Consensus program before you did. There is therefore overwhelming agreement between almost everyone on the basic foundations of Postage Stamp reality and the rejection, even contempt, of the few who have a mind of their own and are prepared to use it. This has two major effects. Firstly, the consensus confirms to the programmed that their download is really how things are. I mean, everyone knows that, right? Secondly, the arrogance and ignorance of Postage Stamp adherents ensure that anyone questioning the program will have unpleasant consequences for seeking their own truth and not picking their perceptions from the shelf marked: 'Things you must believe without question and if you don't you're a dangerous lunatic conspiracy theorist and a harebrained nutter'.

Every government, agency and corporation is founded on the same Postage Stamp prison cell and you can see why so many people believe the same thing while calling it their own 'opinion'. Fusion of governments and corporations in pursuit of the same agenda was the definition of fascism described by Italian dictator Benito Mussolini. The pressure to conform to perceptual norms downloaded for a lifetime is incessant and infiltrates society right



down to family groups that become censors and condemners of their own 'black sheep' for not, ironically, being sheep. We have seen an explosion of that in the 'Covid' era. Cult-owned global media unleashes its propaganda all day every day in support of the Postage Stamp and targets with abuse and ridicule anyone in the public eye who won't bend their mind to the will of the tyranny. Any response to this is denied (certainly in my case). They don't want to give a platform to expose official lies. Cult-owned-and-created Internet giants like Facebook, Google, YouTube and Twitter delete you for having an unapproved opinion. Facebook boasts that its AI censors delete 97-percent of 'hate speech' before anyone even reports it. Much of that 'hate speech' will simply be an opinion that Facebook and its masters don't want people to see. Such perceptual oppression is widely known as fascism. Even Facebook executive Benny Thomas, a 'CEO Global Planning Lead', said in comments secretly recorded by investigative journalism operation Project Veritas that Facebook is 'too powerful' and should be broken up:

I mean, no king in history has been the ruler of two billion people, but Mark Zuckerberg is ... And he's 36. That's too much for a 36-year-old ... You should not have power over two billion people. I just think that's wrong.

Thomas said Facebook-owned platforms like Instagram, Oculus, and WhatsApp needed to be separate companies. 'It's too much power when they're all one together'. That's the way the Cult likes it, however. We have an executive of a Cult organisation in Benny Thomas that doesn't know there is a Cult such is the compartmentalisation. Thomas said that Facebook and Google 'are no longer companies, they're countries'. Actually they are more powerful than countries on the basis that if you control information you control perception and control human society.

## **I love my oppressor**

Another expression of this psychological trickery is for those who realise they are being pressured into compliance to eventually

convince themselves to believe the official narratives to protect their self-respect from accepting the truth that they have succumbed to meek and subservient compliance. Such people become some of the most vehement defenders of the system. You can see them everywhere screaming abuse at those who prefer to think for themselves and by doing so reminding the compliers of their own capitulation to conformity. 'You are talking dangerous nonsense you Covidiot!!' Are you trying to convince me or yourself? It is a potent form of Stockholm syndrome which is defined as: 'A psychological condition that occurs when a victim of abuse identifies and attaches, or bonds, positively with their abuser.' An example is hostages bonding and even 'falling in love' with their kidnappers. The syndrome has been observed in domestic violence, abused children, concentration camp inmates, prisoners of war and many and various Satanic cults. These are some traits of Stockholm syndrome listed at [goodtherapy.org](http://goodtherapy.org):

- Positive regard towards perpetrators of abuse or captor [see 'Covid'].
- Failure to cooperate with police and other government authorities when it comes to holding perpetrators of abuse or kidnapping accountable [or in the case of 'Covid' cooperating with the police to enforce and defend their captors' demands].
- Little or no effort to escape [see 'Covid'].
- Belief in the goodness of the perpetrators or kidnappers [see 'Covid'].
- Appeasement of captors. This is a manipulative strategy for maintaining one's safety. As victims get rewarded – perhaps with less abuse or even with life itself – their appeasing behaviours are reinforced [see 'Covid'].
- Learned helplessness. This can be akin to 'if you can't beat 'em, join 'em'. As the victims fail to escape the abuse or captivity, they may start giving up and soon realize it's just easier for everyone if they acquiesce all their power to their captors [see 'Covid'].

- Feelings of pity toward the abusers, believing they are actually victims themselves. Because of this, victims may go on a crusade or mission to 'save' [protect] their abuser [see the venom unleashed on those challenging the official 'Covid' narrative].
- Unwillingness to learn to detach from their perpetrators and heal. In essence, victims may tend to be less loyal to themselves than to their abuser [ *definitely* see 'Covid'].

Ponder on those traits and compare them with the behaviour of great swathes of the global population who have defended governments and authorities which have spent every minute destroying their lives and livelihoods and those of their children and grandchildren since early 2020 with fascistic lockdowns, house arrest and employment deletion to 'protect' them from a 'deadly virus' that their abusers' perceptually created to bring about this very outcome. We are looking at mass Stockholm syndrome. All those that agree to concede their freedom will believe those perceptions are originating in their own independent 'mind' when in fact by conceding their reality to Stockholm syndrome they have by definition conceded any independence of mind. Listen to the 'opinions' of the acquiescing masses in this 'Covid' era and what gushes forth is the repetition of the official version of everything delivered unprocessed, unfiltered and unquestioned. The whole programming dynamic works this way. I must be free because I'm told that I am and so I think that I am.

You can see what I mean with the chapter theme of 'I'm thinking – Oh, but *are* you?' The great majority are not thinking, let alone for themselves. They are repeating what authority has told them to believe which allows them to be controlled. Weaving through this mentality is the fear that the 'conspiracy theorists' are right and this again explains the often hysterical abuse that ensues when you dare to contest the official narrative of anything. Denial is the mechanism of hiding from yourself what you don't want to be true. Telling people what they want to hear is easy, but it's an infinitely greater challenge to tell them what they would rather not be happening.

One is akin to pushing against an open door while the other is met with vehement resistance no matter what the scale of evidence. I don't want it to be true so I'll convince myself that it's not. Examples are everywhere from the denial that a partner is cheating despite all the signs to the reflex-action rejection of any idea that world events in which country after country act in exactly the same way are centrally coordinated. To accept the latter is to accept that a force of unspeakable evil is working to destroy your life and the lives of your children with nothing too horrific to achieve that end. Who the heck wants that to be true? But if we don't face reality the end is duly achieved and the consequences are far worse and ongoing than breaking through the walls of denial today with the courage to make a stand against tyranny.

### **Connect the dots – but how?**

A crucial aspect of perceptual programming is to portray a world in which everything is random and almost nothing is connected to anything else. Randomness cannot be coordinated by its very nature and once you perceive events as random the idea they could be connected is waved away as the rantings of the tinfoil-hat brigade. You can't plan and coordinate random you idiot! No, you can't, but you can hide the coldly-calculated and long-planned behind the *illusion* of randomness. A foundation manifestation of the Renegade Mind is to scan reality for patterns that connect the apparently random and turn pixels and dots into pictures. This is the way I work and have done so for more than 30 years. You look for similarities in people, modus operandi and desired outcomes and slowly, then ever quicker, the picture forms. For instance: There would seem to be no connection between the 'Covid pandemic' hoax and the human-caused global-warming hoax and yet they are masks (appropriately) on the same face seeking the same outcome. Those pushing the global warming myth through the Club of Rome and other Cult agencies are driving the lies about 'Covid' – Bill Gates is an obvious one, but they are endless. Why would the same people be involved in both when they are clearly not connected? Oh, but they

are. Common themes with personnel are matched by common goals. The 'solutions' to both 'problems' are centralisation of global power to impose the will of the few on the many to 'save' humanity from 'Covid' and save the planet from an 'existential threat' (we need 'zero Covid' and 'zero carbon emissions'). These, in turn, connect with the 'dot' of globalisation which was coined to describe the centralisation of global power in every area of life through incessant political and corporate expansion, trading blocks and superstates like the European Union. If you are the few and you want to control the many you have to centralise power and decision-making. The more you centralise power the more power the few at the centre will have over the many; and the more that power is centralised the more power those at the centre have to centralise even quicker. The momentum of centralisation gets faster and faster which is exactly the process we have witnessed. In this way the hoaxed 'pandemic' and the fakery of human-caused global warming serve the interests of globalisation and the seizure of global power in the hands of the Cult inner-circle which is behind 'Covid', 'climate change' and globalisation. At this point random 'dots' become a clear and obvious picture or pattern.

Klaus Schwab, the classic Bond villain who founded the Cult's Gates-funded World Economic Forum, published a book in 2020, *The Great Reset*, in which he used the 'problem' of 'Covid' to justify a total transformation of human society to 'save' humanity from 'climate change'. Schwab said: 'The pandemic represents a rare but narrow window of opportunity to reflect, reimagine, and reset our world.' What he didn't mention is that the Cult he serves is behind both hoaxes as I show in my book *The Answer*. He and the Cult don't have to reimagine the world. They know precisely what they want and that's why they destroyed human society with 'Covid' to 'build back better' in their grand design. Their job is not to imagine, but to get humanity to imagine and agree with their plans while believing it's all random. It must be pure coincidence that 'The Great Reset' has long been the Cult's code name for the global imposition of fascism and replaced previous code-names of the 'New World

Order' used by Cult frontmen like Father George Bush and the 'New Order of the Ages' which emerged from Freemasonry and much older secret societies. New Order of the Ages appears on the reverse of the Great Seal of the United States as 'Novus ordo seclorum' underneath the Cult symbol used since way back of the pyramid and all seeing-eye (Fig 3). The pyramid is the hierarchy of human control headed by the illuminated eye that symbolises the force behind the Cult which I will expose in later chapters. The term 'Annuit Coeptis' translates as 'He favours our undertaking'. We are told the 'He' is the Christian god, but 'He' is not as I will be explaining.



**Figure 3:** The all-seeing eye of the Cult 'god' on the Freemason-designed Great Seal of the United States and also on the dollar bill.

## **Having you on**

Two major Cult techniques of perceptual manipulation that relate to all this are what I have called since the 1990s Problem-Reaction-Solution (PRS) and the Totalitarian Tiptoe (TT). They can be uncovered by the inquiring mind with a simple question: Who benefits? The answer usually identifies the perpetrators of a given action or happening through the concept of 'he who most benefits from a crime is the one most likely to have committed it'. The Latin 'Cue bono?' – Who benefits? – is widely attributed to the Roman orator and statesman Marcus Tullius Cicero. No wonder it goes back so far when the concept has been relevant to human behaviour since

history was recorded. Problem-Reaction-Solution is the technique used to manipulate us every day by covertly creating a problem (or the illusion of one) and offering the solution to the problem (or the illusion of one). In the first phase you create the problem and blame someone or something else for why it has happened. This may relate to a financial collapse, terrorist attack, war, global warming or pandemic, anything in fact that will allow you to impose the 'solution' to change society in the way you desire at that time. The 'problem' doesn't have to be real. PRS is manipulation of perception and all you need is the population to believe the problem is real. Human-caused global warming and the 'Covid pandemic' only have to be *perceived* to be real for the population to accept the 'solutions' of authority. I refer to this technique as NO-Problem-Reaction-Solution. Billions did not meekly accept house arrest from early 2020 because there was a real deadly 'Covid pandemic' but because they perceived – believed – that to be the case. The antidote to Problem-Reaction-Solution is to ask who benefits from the proposed solution. Invariably it will be anyone who wants to justify more control through deletion of freedom and centralisation of power and decision-making.

The two world wars were Problem-Reaction-Solutions that transformed and realigned global society. Both were manipulated into being by the Cult as I have detailed in books since the mid-1990s. They dramatically centralised global power, especially World War Two, which led to the United Nations and other global bodies thanks to the overt and covert manipulations of the Rockefeller family and other Cult bloodlines like the Rothschilds. The UN is a stalking horse for full-blown world government that I will come to shortly. The land on which the UN building stands in New York was donated by the Rockefellers and the same Cult family was behind Big Pharma scalpel and drug 'medicine' and the creation of the World Health Organization as part of the UN. They have been stalwarts of the eugenics movement and funded Hitler's race-purity expert' Ernst Rudin. The human-caused global warming hoax has been orchestrated by the Club of Rome through the UN which is

manufacturing both the 'problem' through its Intergovernmental Panel on Climate Change and imposing the 'solution' through its Agenda 21 and Agenda 2030 which demand the total centralisation of global power to 'save the world' from a climate hoax the United Nations is itself perpetrating. What a small world the Cult can be seen to be particularly among the inner circles. The bedfellow of Problem-Reaction-Solution is the Totalitarian Tiptoe which became the Totalitarian Sprint in 2020. The technique is fashioned to hide the carefully-coordinated behind the cover of apparently random events. You start the sequence at 'A' and you know you are heading for 'Z'. You don't want people to know that and each step on the journey is presented as a random happening while all the steps strung together lead in the same direction. The speed may have quickened dramatically in recent times, but you can still see the incremental approach of the Tiptoe in the case of 'Covid' as each new imposition takes us deeper into fascism. Tell people they have to do this or that to get back to 'normal', then this and this and this. With each new demand adding to the ones that went before the population's freedom is deleted until it disappears. The spider wraps its web around the flies more comprehensively with each new diktat. I'll highlight this in more detail when I get to the 'Covid' hoax and how it has been pulled off. Another prime example of the Totalitarian Tiptoe is how the Cult-created European Union went from a 'free-trade zone' to a centralised bureaucratic dictatorship through the Tiptoe of incremental centralisation of power until nations became mere administrative units for Cult-owned dark suits in Brussels.

The antidote to ignorance is knowledge which the Cult seeks vehemently to deny us, but despite the systematic censorship to that end the Renegade Mind can overcome this by vociferously seeking out the facts no matter the impediments put in the way. There is also a method of thinking and perceiving – *knowing* – that doesn't even need names, dates, place-type facts to identify the patterns that reveal the story. I'll get to that in the final chapter. All you need to know about the manipulation of human society and to what end is still out there – *at the time of writing* – in the form of books, videos



and websites for those that really want to breach the walls of programmed perception. To access this knowledge requires the abandonment of the mainstream media as a source of information in the awareness that this is owned and controlled by the Cult and therefore promotes mass perceptions that suit the Cult. Mainstream media lies all day, every day. That is its function and very reason for being. Where it does tell the truth, here and there, is only because the truth and the Cult agenda very occasionally coincide. If you look for fact and insight to the BBC, CNN and virtually all the rest of them you are asking to be conned and perceptually programmed.

### **Know the outcome and you'll see the journey**

Events seem random when you have no idea where the world is being taken. Once you do the random becomes the carefully planned. Know the outcome and you'll see the journey is a phrase I have been using for a long time to give context to daily happenings that appear unconnected. Does a problem, or illusion of a problem, trigger a proposed 'solution' that further drives society in the direction of the outcome? Invariably the answer will be yes and the random – *abracadabra* – becomes the clearly coordinated. So what is this outcome that unlocks the door to a massively expanded understanding of daily events? I will summarise its major aspects – the fine detail is in my other books – and those new to this information will see that the world they thought they were living in is a very different place. The foundation of the Cult agenda is the incessant centralisation of power and all such centralisation is ultimately in pursuit of Cult control on a global level. I have described for a long time the planned world structure of top-down dictatorship as the Hunger Games Society. The term obviously comes from the movie series which portrayed a world in which a few living in military-protected hi-tech luxury were the overlords of a population condemned to abject poverty in isolated 'sectors' that were not allowed to interact. 'Covid' lockdowns and travel bans anyone? The 'Hunger Games' pyramid of structural control has the inner circle of the Cult at the top with pretty much the entire

population at the bottom under their control through dependency for survival on the Cult. The whole structure is planned to be protected and enforced by a military-police state (Fig 4).

Here you have the reason for the global lockdowns of the fake pandemic to coldly destroy independent incomes and livelihoods and make everyone dependent on the 'state' (the Cult that controls the 'states'). I have warned in my books for many years about the plan to introduce a 'guaranteed income' – a barely survivable pittance – designed to impose dependency when employment was destroyed by AI technology and now even more comprehensively at great speed by the 'Covid' scam. Once the pandemic was played and lockdown consequences began to delete independent income the authorities began to talk right on cue about the need for a guaranteed income and a 'Great Reset'. Guaranteed income will be presented as benevolent governments seeking to help a desperate people – desperate as a direct result of actions of the same governments. The truth is that such payments are a trap. You will only get them if you do exactly what the authorities demand including mass vaccination (genetic manipulation). We have seen this theme already in Australia where those dependent on government benefits have them reduced if parents don't agree to have their children vaccinated according to an insane health-destroying government-dictated schedule. Calculated economic collapse applies to governments as well as people. The Cult wants rid of countries through the creation of a world state with countries broken up into regions ruled by a world government and super states like the European Union. Countries must be bankrupted, too, to this end and it's being achieved by the trillions in 'rescue packages' and furlough payments, trillions in lost taxation, and money-no-object spending on 'Covid' including constant all-medium advertising (programming) which has made the media dependent on government for much of its income. The day of reckoning is coming – as planned – for government spending and given that it has been made possible by printing money and not by production/taxation there is inflation on the way that has the

potential to wipe out monetary value. In that case there will be no need for the Cult to steal your money. It just won't be worth anything (see the German Weimar Republic before the Nazis took over). Many have been okay with lockdowns while getting a percentage of their income from so-called furlough payments without having to work. Those payments are dependent, however, on people having at least a theoretical job with a business considered non-essential and ordered to close. As these business go under because they are closed by lockdown after lockdown the furlough stops and it will for everyone eventually. Then what? The 'then what?' is precisely the idea.



**Figure 4:** The Hunger Games Society structure I have long warned was planned and now the 'Covid' hoax has made it possible. This is the real reason for lockdowns.

## Hired hands

Between the Hunger Games Cult elite and the dependent population is planned to be a vicious military-police state (a fusion of the two into one force). This has been in the making for a long time with police looking ever more like the military and carrying weapons to match. The pandemic scam has seen this process accelerate so fast as

lockdown house arrest is brutally enforced by carefully recruited fascist minds and gormless system-servers. The police and military are planned to merge into a centrally-directed world army in a global structure headed by a world government which wouldn't be elected even by the election fixes now in place. The world army is not planned even to be human and instead wars would be fought, primarily against the population, using robot technology controlled by artificial intelligence. I have been warning about this for decades and now militaries around the world are being transformed by this very AI technology. The global regime that I describe is a particular form of fascism known as a technocracy in which decisions are not made by clueless and co-opted politicians but by unelected technocrats – scientists, engineers, technologists and bureaucrats. Cult-owned-and-controlled Silicon Valley giants are examples of technocracy and they already have far more power to direct world events than governments. They are with their censorship *selecting* governments. I know that some are calling the 'Great Reset' a Marxist communist takeover, but fascism and Marxism are different labels for the same tyranny. Tell those who lived in fascist Germany and Stalinist Russia that there was a difference in the way their freedom was deleted and their lives controlled. I could call it a fascist technocracy or a Marxist technocracy and they would be equally accurate. The Hunger Games society with its world government structure would oversee a world army, world central bank and single world cashless currency imposing its will on a microchipped population (Fig 5). Scan its different elements and see how the illusory pandemic is forcing society in this very direction at great speed. Leaders of 23 countries and the World Health Organization (WHO) backed the idea in March, 2021, of a global treaty for 'international cooperation' in 'health emergencies' and nations should 'come together as a global community for peaceful cooperation that extends beyond this crisis'. Cut the Orwellian bullshit and this means another step towards global government. The plan includes a cashless digital money system that I first warned about in 1993. Right at the start of 'Covid' the deeply corrupt Tedros

Adhanom Ghebreyesus, the crooked and merely gofer 'head' of the World Health Organization, said it was possible to catch the 'virus' by touching cash and it was better to use cashless means. The claim was ridiculous nonsense and like the whole 'Covid' mind-trick it was nothing to do with 'health' and everything to do with pushing every aspect of the Cult agenda. As a result of the Tedros lie the use of cash has plummeted. The Cult script involves a single world digital currency that would eventually be technologically embedded in the body. China is a massive global centre for the Cult and if you watch what is happening there you will know what is planned for everywhere. The Chinese government is developing a digital currency which would allow fines to be deducted immediately via AI for anyone caught on camera breaking its fantastic list of laws and the money is going to be programmable with an expiry date to ensure that no one can accrue wealth except the Cult and its operatives.



**Figure 5:** The structure of global control the Cult has been working towards for so long and this has been enormously advanced by the 'Covid' illusion.

## **Serfdom is so smart**

The Cult plan is far wider, extreme, and more comprehensive than even most conspiracy researchers appreciate and I will come to the true depths of deceit and control in the chapters 'Who controls the

Cult?’ and ‘Escaping Wetiko’. Even the world that we know is crazy enough. We are being deluged with ever more sophisticated and controlling technology under the heading of ‘smart’. We have smart televisions, smart meters, smart cards, smart cars, smart driving, smart roads, smart pills, smart patches, smart watches, smart skin, smart borders, smart pavements, smart streets, smart cities, smart communities, smart environments, smart growth, smart planet ... smart *everything* around us. Smart technologies and methods of operation are designed to interlock to create a global Smart Grid connecting the entirety of human society including human minds to create a centrally-dictated ‘hive’ mind. ‘Smart cities’ is code for densely-occupied megacities of total surveillance and control through AI. Ever more destructive frequency communication systems like 5G have been rolled out without any official testing for health and psychological effects (colossal). 5G/6G/7G systems are needed to run the Smart Grid and each one becomes more destructive of body and mind. Deleting independent income is crucial to forcing people into these AI-policed prisons by ending private property ownership (except for the Cult elite). The Cult’s Great Reset now openly foresees a global society in which no one will own any possessions and everything will be rented while the Cult would own literally everything under the guise of government and corporations. The aim has been to use the lockdowns to destroy sources of income on a mass scale and when the people are destitute and in unrepayable amounts of debt (problem) Cult assets come forward with the pledge to write-off debt in return for handing over all property and possessions (solution). Everything – literally everything including people – would be connected to the Internet via AI. I was warning years ago about the coming Internet of Things (IoT) in which all devices and technology from your car to your fridge would be plugged into the Internet and controlled by AI. Now we are already there with much more to come. The next stage is the Internet of Everything (IoE) which is planned to include the connection of AI to the human brain and body to replace the human mind with a centrally-controlled AI mind. Instead of perceptions

being manipulated through control of information and censorship those perceptions would come direct from the Cult through AI. What do you think? You think whatever AI decides that you think. In human terms there would be no individual 'think' any longer. Too incredible? The ravings of a lunatic? Not at all. Cult-owned crazies in Silicon Valley have been telling us the plan for years without explaining the real motivation and calculated implications. These include Google executive and 'futurist' Ray Kurzweil who highlights the year 2030 for when this would be underway. He said:

Our thinking ... will be a hybrid of biological and non-biological thinking ... humans will be able to extend their limitations and 'think in the cloud' ... We're going to put gateways to the cloud in our brains ... We're going to gradually merge and enhance ourselves ... In my view, that's the nature of being human – we transcend our limitations.

As the technology becomes vastly superior to what we are then the small proportion that is still human gets smaller and smaller and smaller until it's just utterly negligible.

The sales-pitch of Kurzweil and Cult-owned Silicon Valley is that this would make us 'super-human' when the real aim is to make us post-human and no longer 'human' in the sense that we have come to know. The entire global population would be connected to AI and become the centrally-controlled 'hive-mind' of externally-delivered perceptions. The Smart Grid being installed to impose the Cult's will on the world is being constructed to allow particular locations – even one location – to control the whole global system. From these prime control centres, which absolutely include China and Israel, anything connected to the Internet would be switched on or off and manipulated at will. Energy systems could be cut, communication via the Internet taken down, computer-controlled driverless autonomous vehicles driven off the road, medical devices switched off, the potential is limitless given how much AI and Internet connections now run human society. We have seen nothing yet if we allow this to continue. Autonomous vehicle makers are working with law enforcement to produce cars designed to automatically pull over if they detect a police or emergency vehicle flashing from up to 100 feet away. At a police stop the car would be unlocked and the

window rolled down automatically. Vehicles would only take you where the computer (the state) allowed. The end of petrol vehicles and speed limiters on all new cars in the UK and EU from 2022 are steps leading to electric computerised transport over which ultimately you have no control. The picture is far bigger even than the Cult global network or web and that will become clear when I get to the nature of the 'spider'. There is a connection between all these happenings and the instigation of DNA-manipulating 'vaccines' (which aren't 'vaccines') justified by the 'Covid' hoax. That connection is the unfolding plan to transform the human body from a biological to a synthetic biological state and this is why synthetic biology is such a fast-emerging discipline of mainstream science. 'Covid vaccines' are infusing self-replicating synthetic genetic material into the cells to cumulatively take us on the Totalitarian Tiptoe from Human 1.0 to the synthetic biological Human 2.0 which will be physically and perceptually attached to the Smart Grid to one hundred percent control every thought, perception and deed. Humanity needs to wake up and *fast*.

This is the barest explanation of where the 'outcome' is planned to go but it's enough to see the journey happening all around us. Those new to this information will already see 'Covid' in a whole new context. I will add much more detail as we go along, but for the minutiae evidence see my mega-works, *The Answer*, *The Trigger* and *Everything You Need to Know But Have Never Been Told*.

Now – how does a Renegade Mind see the 'world'?



## CHAPTER TWO

# Renegade Perception

*It is one thing to be clever and another to be wise*

George R.R. Martin

A simple definition of the difference between a programmed mind and a Renegade Mind would be that one sees only dots while the other connects them to see the picture. Reading reality with accuracy requires the observer to (a) know the planned outcome and (b) realise that everything, but *everything*, is connected.

The entirety of infinite reality is connected – that’s its very nature – and with human society an expression of infinite reality the same must apply. Simple cause and effect is a connection. The effect is triggered by the cause and the effect then becomes the cause of another effect. Nothing happens in isolation because it *can’t*. Life in whatever reality is simple choice and consequence. We make choices and these lead to consequences. If we don’t like the consequences we can make different choices and get different consequences which lead to other choices and consequences. The choice and the consequence are not only connected they are indivisible. You can’t have one without the other as an old song goes. A few cannot control the world unless those being controlled allow that to happen – cause and effect, choice and consequence. Control – who has it and who doesn’t – is a two-way process, a symbiotic relationship, involving the controller and controlled. ‘They took my freedom away!!’ Well, yes, but you also gave it to them. Humanity is

subjected to mass control because humanity has acquiesced to that control. This is all cause and effect and literally a case of give and take. In the same way world events of every kind are connected and the Cult works incessantly to sell the illusion of the random and coincidental to maintain the essential (to them) perception of dots that hide the picture. Renegade Minds know this and constantly scan the world for patterns of connection. This is absolutely pivotal in understanding the happenings in the world and without that perspective clarity is impossible. First you know the planned outcome and then you identify the steps on the journey – the day-by-day apparently random which, when connected in relation to the outcome, no longer appear as individual events, but as the proverbial *chain* of events leading in the same direction. I'll give you some examples:

### **Political puppet show**

We are told to believe that politics is 'adversarial' in that different parties with different beliefs engage in an endless tussle for power. There may have been some truth in that up to a point – and only a point – but today divisions between 'different' parties are rhetorical not ideological. Even the rhetorical is fusing into one-speak as the parties eject any remaining free thinkers while others succumb to the ever-gathering intimidation of anyone with the 'wrong' opinion. The Cult is not a new phenomenon and can be traced back thousands of years as my books have documented. Its intergenerational initiates have been manipulating events with increasing effect the more that global power has been centralised. In ancient times the Cult secured control through the system of monarchy in which 'special' bloodlines (of which more later) demanded the right to rule as kings and queens simply by birthright and by vanquishing others who claimed the same birthright. There came a time, however, when people had matured enough to see the unfairness of such tyranny and demanded a say in who governed them. Note the word – *governed* them. Not served them – *governed* them, hence government defined as 'the political direction and control exercised over the

actions of the members, citizens, or inhabitants of communities, societies, and states; direction of the affairs of a state, community, etc.' Governments exercise control over rather than serve just like the monarchies before them. Bizarrely there are still countries like the United Kingdom which are ruled by a monarch *and* a government that officially answers to the monarch. The UK head of state and that of Commonwealth countries such as Canada, Australia and New Zealand is 'selected' by who in a *single family* had unprotected sex with whom and in what order. Pinch me it can't be true. Ouch! Shit, it is. The demise of monarchies in most countries offered a potential vacuum in which some form of free and fair society could arise and the Cult had that base covered. Monarchies had served its interests but they couldn't continue in the face of such widespread opposition and, anyway, replacing a 'royal' dictatorship that people could see with a dictatorship 'of the people' hiding behind the concept of 'democracy' presented far greater manipulative possibilities and ways of hiding coordinated tyranny behind the illusion of 'freedom'.

Democracy is quite wrongly defined as government selected by the population. This is not the case at all. It is government selected by *some* of the population (and then only in theory). This 'some' doesn't even have to be the majority as we have seen so often in first-past-the-post elections in which the so-called majority party wins fewer votes than the 'losing' parties combined. Democracy can give total power to a party in government from a minority of the votes cast. It's a sleight of hand to sell tyranny as freedom. Seventy-four million Trump-supporting Americans didn't vote for the 'Democratic' Party of Joe Biden in the distinctly dodgy election in 2020 and yet far from acknowledging the wishes and feelings of that great percentage of American society the Cult-owned Biden government set out from day one to destroy them and their right to a voice and opinion. Empty shell Biden and his Cult handlers said they were doing this to 'protect democracy'. Such is the level of lunacy and sickness to which politics has descended. Connect the dots and relate them to the desired outcome – a world government run by self-appointed technocrats and no longer even elected

politicians. While operating through its political agents in government the Cult is at the same time encouraging public disdain for politicians by putting idiots and incompetents in theoretical power on the road to deleting them. The idea is to instil a public reaction that says of the technocrats: 'Well, they couldn't do any worse than the pathetic politicians.' It's all about controlling perception and Renegade Minds can see through that while programmed minds cannot when they are ignorant of both the planned outcome and the manipulation techniques employed to secure that end. This knowledge can be learned, however, and fast if people choose to get informed.

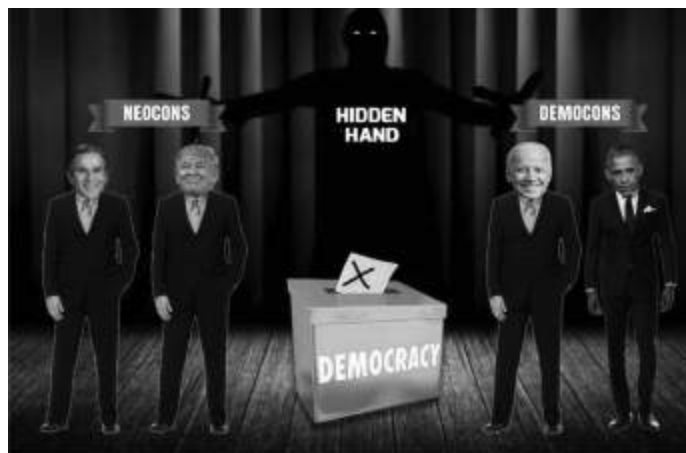
Politics may at first sight appear very difficult to control from a central point. I mean look at the 'different' parties and how would you be able to oversee them all and their constituent parts? In truth, it's very straightforward because of their structure. We are back to the pyramid of imposition and acquiescence. Organisations are structured in the same way as the system as a whole. Political parties are not open forums of free expression. They are hierarchies. I was a national spokesman for the British Green Party which claimed to be a different kind of politics in which influence and power was devolved; but I can tell you from direct experience – and it's far worse now – that Green parties are run as hierarchies like all the others however much they may try to hide that fact or kid themselves that it's not true. A very few at the top of all political parties are directing policy and personnel. They decide if you are elevated in the party or serve as a government minister and to do that you have to be a yes man or woman. Look at all the maverick political thinkers who never ascended the greasy pole. If you want to progress within the party or reach 'high-office' you need to fall into line and conform. Exceptions to this are rare indeed. Should you want to run for parliament or Congress you have to persuade the local or state level of the party to select you and for that you need to play the game as dictated by the hierarchy. If you secure election and wish to progress within the greater structure you need to go on conforming to what is acceptable to those running the hierarchy

from the peak of the pyramid. Political parties are perceptual gulags and the very fact that there are party 'Whips' appointed to 'whip' politicians into voting the way the hierarchy demands exposes the ridiculous idea that politicians are elected to serve the people they are supposed to represent. Cult operatives and manipulation has long seized control of major parties that have any chance of forming a government and at least most of those that haven't. A new party forms and the Cult goes to work to infiltrate and direct. This has reached such a level today that you see video compilations of 'leaders' of all parties whether Democrats, Republicans, Conservative, Labour and Green parroting the same Cult mantra of 'Build Back Better' and the 'Great Reset' which are straight off the Cult song-sheet to describe the transformation of global society in response to the Cult-instigated hoaxes of the 'Covid pandemic' and human-caused 'climate change'. To see Caroline Lucas, the Green Party MP that I knew when I was in the party in the 1980s, speaking in support of plans proposed by Cult operative Klaus Schwab representing the billionaire global elite is a real head-shaker.

### **Many parties – one master**

The party system is another mind-trick and was instigated to change the nature of the dictatorship by swapping 'royalty' for dark suits that people believed – though now ever less so – represented their interests. Understanding this trick is to realise that a single force (the Cult) controls all parties either directly in terms of the major ones or through manipulation of perception and ideology with others. You don't need to manipulate Green parties to demand your transformation of society in the name of 'climate change' when they are obsessed with the lie that this is essential to 'save the planet'. You just give them a platform and away they go serving your interests while believing they are being environmentally virtuous. America's political structure is a perfect blueprint for how the two or multi-party system is really a one-party state. The Republican Party is controlled from one step back in the shadows by a group made up of billionaires and their gofers known as neoconservatives or Neocons.

I have exposed them in fine detail in my books and they were the driving force behind the policies of the imbecilic presidency of Boy George Bush which included 9/11 (see *The Trigger* for a comprehensive demolition of the official story), the subsequent 'war on terror' (war of terror) and the invasions of Afghanistan and Iraq. The latter was a No-Problem-Reaction-Solution based on claims by Cult operatives, including Bush and British Prime Minister Tony Blair, about Saddam Hussein's 'weapons of mass destruction' which did not exist as war criminals Bush and Blair well knew.



**Figure 6:** Different front people, different parties – same control system.

The Democratic Party has its own 'Neocon' group controlling from the background which I call the 'Democons' and here's the penny-drop – the Neocons and Democons answer to the same masters one step further back into the shadows (Fig 6). At that level of the Cult the Republican and Democrat parties are controlled by the same people and no matter which is in power the Cult is in power. This is how it works in almost every country and certainly in Britain with Conservative, Labour, Liberal Democrat and Green parties now all on the same page whatever the rhetoric may be in their feeble attempts to appear different. Neocons operated at the time of Bush through a think tank called The Project for the New American Century which in September, 2000, published a document entitled *Rebuilding America's Defenses: Strategies, Forces, and Resources*

*For a New Century* demanding that America fight ‘multiple, simultaneous major theatre wars’ as a ‘core mission’ to force regime-change in countries including Iraq, Libya and Syria. Neocons arranged for Bush (‘Republican’) and Blair (‘Labour Party’) to front-up the invasion of Iraq and when they departed the Democons orchestrated the targeting of Libya and Syria through Barack Obama (‘Democrat’) and British Prime Minister David Cameron (‘Conservative Party’). We have ‘different’ parties and ‘different’ people, but the same unfolding script. The more the Cult has seized the reigns of parties and personnel the more their policies have transparently pursued the same agenda to the point where the fascist ‘Covid’ impositions of the Conservative junta of Jackboot Johnson in Britain were opposed by the Labour Party because they were not fascist enough. The Labour Party is likened to the US Democrats while the Conservative Party is akin to a British version of the Republicans and on both sides of the Atlantic they all speak the same language and support the direction demanded by the Cult although some more enthusiastically than others. It’s a similar story in country after country because it’s all centrally controlled. Oh, but what about Trump? I’ll come to him shortly. Political ‘choice’ in the ‘party’ system goes like this: You vote for Party A and they get into government. You don’t like what they do so next time you vote for Party B and they get into government. You don’t like what they do when it’s pretty much the same as Party A and why wouldn’t that be with both controlled by the same force? Given that only two, sometimes three, parties have any chance of forming a government to get rid of Party B that you don’t like you have to vote again for Party A which ... you don’t like. This, ladies and gentlemen, is what they call ‘democracy’ which we are told – wrongly – is a term interchangeable with ‘freedom’.

## **The cult of cults**

At this point I need to introduce a major expression of the Global Cult known as Sabbatian-Frankism. Sabbatian is also spelt as Sabbatean. I will summarise here. I have published major exposés

and detailed background in other works. Sabbatian-Frankism combines the names of two frauds posing as 'Jewish' men, Sabbatai Zevi (1626-1676), a rabbi, black magician and occultist who proclaimed he was the Jewish messiah; and Jacob Frank (1726-1791), the Polish 'Jew', black magician and occultist who said he was the reincarnation of 'messiah' Zevi and biblical patriarch Jacob. They worked across two centuries to establish the Sabbatian-Frankist cult that plays a major, indeed central, role in the manipulation of human society by the Global Cult which has its origins much further back in history than Sabbatai Zevi. I should emphasise two points here in response to the shrill voices that will scream 'anti-Semitism': (1) Sabbatian-Frankists are NOT Jewish and only pose as such to hide their cult behind a Jewish façade; and (2) my information about this cult has come from Jewish sources who have long realised that their society and community has been infiltrated and taken over by interloper Sabbatian-Frankists. Infiltration has been the foundation technique of Sabbatian-Frankism from its official origin in the 17th century. Zevi's Sabbatian sect attracted a massive following described as the biggest messianic movement in Jewish history, spreading as far as Africa and Asia, and he promised a return for the Jews to the 'Promised Land' of Israel. Sabbatianism was not Judaism but an inversion of everything that mainstream Judaism stood for. So much so that this sinister cult would have a feast day when Judaism had a fast day and whatever was forbidden in Judaism the Sabbatians were encouraged and even commanded to do. This included incest and what would be today called Satanism. Members were forbidden to marry outside the sect and there was a system of keeping their children ignorant of what they were part of until they were old enough to be trusted not to unknowingly reveal anything to outsiders. The same system is employed to this day by the Global Cult in general which Sabbatian-Frankism has enormously influenced and now largely controls.

Zevi and his Sabbatians suffered a setback with the intervention by the Sultan of the Islamic Ottoman Empire in the Middle East and what is now the Republic of Turkey where Zevi was located. The



Sultan gave him the choice of proving his 'divinity', converting to Islam or facing torture and death. Funnily enough Zevi chose to convert or at least appear to. Some of his supporters were disillusioned and drifted away, but many did not with 300 families also converting – only in theory – to Islam. They continued behind this Islamic smokescreen to follow the goals, rules and rituals of Sabbatianism and became known as 'crypto-Jews' or the 'Dönme' which means 'to turn'. This is rather ironic because they didn't 'turn' and instead hid behind a fake Islamic persona. The process of appearing to be one thing while being very much another would become the calling card of Sabbatianism especially after Zevi's death and the arrival of the Satanist Jacob Frank in the 18th century when the cult became Sabbatian-Frankism and plumbed still new depths of depravity and infiltration which included – still includes – human sacrifice and sex with children. Wherever Sabbatians go paedophilia and Satanism follow and is it really a surprise that Hollywood is so infested with child abuse and Satanism when it was established by Sabbatian-Frankists and is still controlled by them? Hollywood has been one of the prime vehicles for global perceptual programming and manipulation. How many believe the version of 'history' portrayed in movies when it is a travesty and inversion (again) of the truth? Rabbi Marvin Antelman describes Frankism in his book, *To Eliminate the Opiate*, as 'a movement of complete evil' while Jewish professor Gershom Scholem said of Frank in *The Messianic Idea in Judaism*: 'In all his actions [he was] a truly corrupt and degenerate individual ... one of the most frightening phenomena in the whole of Jewish history.' Frank was excommunicated by traditional rabbis, as was Zevi, but Frank was undeterred and enjoyed vital support from the House of Rothschild, the infamous banking dynasty whose inner-core are Sabbatian-Frankists and not Jews. Infiltration of the Roman Church and Vatican was instigated by Frank with many Dönme 'turning' again to convert to Roman Catholicism with a view to hijacking the reins of power. This was the ever-repeating modus operandi and continues to be so. Pose as an advocate of the religion, culture or country that you want to control and then

manipulate your people into the positions of authority and influence largely as advisers, administrators and Svengalis for those that appear to be in power. They did this with Judaism, Christianity (Christian Zionism is part of this), Islam and other religions and nations until Sabbatian-Frankism spanned the world as it does today.

### **Sabbatian Saudis and the terror network**

One expression of the Sabbatian-Frankist Dönme within Islam is the ruling family of Saudi Arabia, the House of Saud, through which came the vile distortion of Islam known as Wahhabism. This is the violent creed followed by terrorist groups like Al-Qaeda and ISIS or Islamic State. Wahhabism is the hand-chopping, head-chopping 'religion' of Saudi Arabia which is used to keep the people in a constant state of fear so the interloper House of Saud can continue to rule. Al-Qaeda and Islamic State were lavishly funded by the House of Saud while being created and directed by the Sabbatian-Frankist network in the United States that operates through the Pentagon, CIA and the government in general of whichever 'party'. The front man for the establishment of Wahhabism in the middle of the 18th century was a Sabbatian-Frankist 'crypto-Jew' posing as Islamic called Muhammad ibn Abd al-Wahhab. His daughter would marry the son of Muhammad bin Saud who established the first Saudi state before his death in 1765 with support from the British Empire. Bin Saud's successors would establish modern Saudi Arabia in league with the British and Americans in 1932 which allowed them to seize control of Islam's major shrines in Mecca and Medina. They have dictated the direction of Sunni Islam ever since while Iran is the major centre of the Shiite version and here we have the source of at least the public conflict between them. The Sabbatian network has used its Wahhabi extremists to carry out Problem-Reaction-Solution terrorist attacks in the name of 'Al-Qaeda' and 'Islamic State' to justify a devastating 'war on terror', ever-increasing surveillance of the population and to terrify people into compliance. Another insight of the Renegade Mind is the streetwise understanding that

just because a country, location or people are attacked doesn't mean that those apparently representing that country, location or people are not behind the attackers. Often they are *orchestrating* the attacks because of the societal changes that can be then justified in the name of 'saving the population from terrorists'.

I show in great detail in *The Trigger* how Sabbatian-Frankists were the real perpetrators of 9/11 and not '19 Arab hijackers' who were blamed for what happened. Observe what was justified in the name of 9/11 alone in terms of Middle East invasions, mass surveillance and control that fulfilled the demands of the Project for the New American Century document published by the Sabbatian Neocons. What appear to be enemies are on the deep inside players on the same Sabbatian team. Israel and Arab 'royal' dictatorships are all ruled by Sabbatians and the recent peace agreements between Israel and Saudi Arabia, the United Arab Emirates (UAE) and others are only making formal what has always been the case behind the scenes. Palestinians who have been subjected to grotesque tyranny since Israel was bombed and terrorised into existence in 1948 have never stood a chance. Sabbatian-Frankists have controlled Israel (so the constant theme of violence and war which Sabbatians love) and they have controlled the Arab countries that Palestinians have looked to for real support that never comes. 'Royal families' of the Arab world in Saudi Arabia, Bahrain, UAE, etc., are all Sabbatians with allegiance to the aims of the cult and not what is best for their Arabic populations. They have stolen the oil and financial resources from their people by false claims to be 'royal dynasties' with a genetic right to rule and by employing vicious militaries to impose their will.

### **Satanic 'illumination'**

The Satanist Jacob Frank formed an alliance in 1773 with two other Sabbatians, Mayer Amschel Rothschild (1744-1812), founder of the Rothschild banking dynasty, and Jesuit-educated fraudulent Jew, Adam Weishaupt, and this led to the formation of the Bavarian Illuminati, firstly under another name, in 1776. The Illuminati would

be the manipulating force behind the French Revolution (1789-1799) and was also involved in the American Revolution (1775-1783) before and after the Illuminati's official creation. Weishaupt would later become (in public) a Protestant Christian in archetypal Sabbatian style. I read that his name can be decoded as Adam-Weishaupt or 'the first man to lead those who know'. He wasn't a leader in the sense that he was a subordinate, but he did lead those below him in a crusade of transforming human society that still continues today. The theme was confirmed as early as 1785 when a horseman courier called Lanz was reported to be struck by lightning and extensive Illuminati documents were found in his saddlebags. They made the link to Weishaupt and detailed the plan for world takeover. Current events with 'Covid' fascism have been in the making for a very long time. Jacob Frank was jailed for 13 years by the Catholic Inquisition after his arrest in 1760 and on his release he headed for Frankfurt, Germany, home city and headquarters of the House of Rothschild where the alliance was struck with Mayer Amschel Rothschild and Weishaupt. Rothschild arranged for Frank to be given the title of Baron and he became a wealthy nobleman with a big following of Jews in Germany, the Austro-Hungarian Empire and other European countries. Most of them would have believed he was on their side.

The name 'Illuminati' came from the Zohar which is a body of works in the Jewish mystical 'bible' called the Kabbalah. 'Zohar' is the foundation of Sabbatian-Frankist belief and in Hebrew 'Zohar' means 'splendour', 'radiance', 'illuminated', and so we have 'Illuminati'. They claim to be the 'Illuminated Ones' from their knowledge systematically hidden from the human population and passed on through generations of carefully-chosen initiates in the global secret society network or Cult. Hidden knowledge includes an awareness of the Cult agenda for the world and the nature of our collective reality that I will explore later. Cult 'illumination' is symbolised by the torch held by the Statue of Liberty which was gifted to New York by French Freemasons in Paris who knew exactly what it represents. 'Liberty' symbolises the goddess worshipped in

Babylon as Queen Semiramis or Ishtar. The significance of this will become clear. Notice again the ubiquitous theme of inversion with the Statue of 'Liberty' really symbolising mass control (Fig 7). A mirror-image statute stands on an island in the River Seine in Paris from where New York Liberty originated (Fig 8). A large replica of the Liberty flame stands on top of the Pont de l'Alma tunnel in Paris where Princess Diana died in a Cult ritual described in *The Biggest Secret*. Lucifer 'the light bringer' is related to all this (and much more as we'll see) and 'Lucifer' is a central figure in Sabbatian-Frankism and its associated Satanism. Sabbatians reject the Jewish Torah, or Pentateuch, the 'five books of Moses' in the Old Testament known as Genesis, Exodus, Leviticus, Numbers, and Deuteronomy which are claimed by Judaism and Christianity to have been dictated by 'God' to Moses on Mount Sinai. Sabbatians say these do not apply to them and they seek to replace them with the Zohar to absorb Judaism and its followers into their inversion which is an expression of a much greater global inversion. They want to delete all religions and force humanity to worship a one-world religion – Sabbatian Satanism that also includes worship of the Earth goddess. Satanic themes are being more and more introduced into mainstream society and while Christianity is currently the foremost target for destruction the others are planned to follow.



**Figure 7:** The Cult goddess of Babylon disguised as the Statue of Liberty holding the flame of Lucifer the 'light bringer'.



**Figure 8:** Liberty's mirror image in Paris where the New York version originated.

## **Marx brothers**

Rabbi Marvin Antelman connects the Illuminati to the Jacobins in *To Eliminate the Opiate* and Jacobins were the force behind the French Revolution. He links both to the Bund der Gerechten, or League of the Just, which was the network that inflicted communism/Marxism on the world. Antelman wrote:

The original inner circle of the Bund der Gerechten consisted of born Catholics, Protestants and Jews [Sabbatian-Frankist infiltrators], and those representatives of respective subdivisions formulated schemes for the ultimate destruction of their faiths. The heretical Catholics laid plans which they felt would take a century or more for the ultimate destruction of the church; the apostate Jews for the ultimate destruction of the Jewish religion.

Sabbatian-created communism connects into this anti-religion agenda in that communism does not allow for the free practice of religion. The Sabbatian 'Bund' became the International Communist Party and Communist League and in 1848 'Marxism' was born with the Communist Manifesto of Sabbatian assets Karl Marx and Friedrich Engels. It is absolutely no coincidence that Marxism, just a different name for fascist and other centrally-controlled tyrannies, is being imposed worldwide as a result of the 'Covid' hoax and nor that Marxist/fascist China was the place where the hoax originated. The reason for this will become very clear in the chapter 'Covid: The calculated catastrophe'. The so-called 'Woke' mentality has hijacked

traditional beliefs of the political left and replaced them with far-right make-believe 'social justice' better known as Marxism. Woke will, however, be swallowed by its own perceived 'revolution' which is really the work of billionaires and billionaire corporations feigning being 'Woke'. Marxism is being touted by Wokers as a replacement for 'capitalism' when we don't have 'capitalism'. We have cartelism in which the market is stitched up by the very Cult billionaires and corporations bankrolling Woke. Billionaires love Marxism which keeps the people in servitude while they control from the top. Terminally naïve Wokers think they are 'changing the world' when it's the Cult that is doing the changing and when they have played their vital part and become surplus to requirements they, too, will be targeted. The Illuminati-Jacobins were behind the period known as 'The Terror' in the French Revolution in 1793 and 1794 when Jacobin Maximillian de Robespierre and his Orwellian 'Committee of Public Safety' killed 17,000 'enemies of the Revolution' who had once been 'friends of the Revolution'. Karl Marx (1818-1883), whose Sabbatian creed of Marxism has cost the lives of at least 100 million people, is a hero once again to Wokers who have been systematically kept ignorant of real history by their 'education' programming. As a result they now promote a Sabbatian 'Marxist' abomination destined at some point to consume them. Rabbi Antelman, who spent decades researching the Sabbatian plot, said of the League of the Just and Karl Marx:

Contrary to popular opinion Karl Marx did not originate the Communist Manifesto. He was paid for his services by the League of the Just, which was known in its country of origin, Germany, as the Bund der Geachteten.

Antelman said the text attributed to Marx was the work of other people and Marx 'was only repeating what others already said'. Marx was 'a hired hack – lackey of the wealthy Illuminists'. Marx famously said that religion was the 'opium of the people' (part of the Sabbatian plan to demonise religion) and Antelman called his books, *To Eliminate the Opiate*. Marx was born Jewish, but his family converted to Christianity (Sabbatian modus operandi) and he

attacked Jews, not least in his book, *A World Without Jews*. In doing so he supported the Sabbatian plan to destroy traditional Jewishness and Judaism which we are clearly seeing today with the vindictive targeting of orthodox Jews by the Sabbatian government of Israel over 'Covid' laws. I don't follow any religion and it has done much damage to the world over centuries and acted as a perceptual straightjacket. Renegade Minds, however, are always asking *why* something is being done. It doesn't matter if they agree or disagree with what is happening – *why* is it happening is the question. The 'why?' can be answered with regard to religion in that religions create interacting communities of believers when the Cult wants to dismantle all discourse, unity and interaction (see 'Covid' lockdowns) and the ultimate goal is to delete all religions for a one-world religion of Cult Satanism worshipping their 'god' of which more later. We see the same 'why?' with gun control in America. I don't have guns and don't want them, but why is the Cult seeking to disarm the population at the same time that law enforcement agencies are armed to their molars and why has every tyrant in history sought to disarm people before launching the final takeover? They include Hitler, Stalin, Pol Pot and Mao who followed confiscation with violent seizing of power. You know it's a Cult agenda by the people who immediately race to the microphones to exploit dead people in multiple shootings. Ultra-Zionist Cult lackey Senator Chuck Schumer was straight on the case after ten people were killed in Boulder, Colorado in March, 2121. Simple rule ... if Schumer wants it the Cult wants it and the same with his ultra-Zionist mate the wild-eyed Senator Adam Schiff. At the same time they were calling for the disarmament of Americans, many of whom live a long way from a police response, Schumer, Schiff and the rest of these pampered clowns were sitting on Capitol Hill behind a razor-wired security fence protected by thousands of armed troops in addition to their own armed bodyguards. Mom and pop in an isolated home? They're just potential mass shooters.

## **Zion Mainframe**



Sabbatian-Frankists and most importantly the Rothschilds were behind the creation of 'Zionism', a political movement that demanded a Jewish homeland in Israel as promised by Sabbatai Zevi. The very symbol of Israel comes from the German meaning of the name Rothschild. Dynasty founder Mayer Amschel Rothschild changed the family name from Bauer to Rothschild, or 'Red-Shield' in German, in deference to the six-pointed 'Star of David' hexagram displayed on the family's home in Frankfurt. The symbol later appeared on the flag of Israel after the Rothschilds were centrally involved in its creation. Hexagrams are not a uniquely Jewish symbol and are widely used in occult ('hidden') networks often as a symbol for Saturn (see my other books for why). Neither are Zionism and Jewishness interchangeable. Zionism is a political movement and philosophy and not a 'race' or a people. Many Jews oppose Zionism and many non-Jews, including US President Joe Biden, call themselves Zionists as does Israel-centric Donald Trump. America's support for the Israel government is pretty much a gimme with ultra-Zionist billionaires and corporations providing fantastic and dominant funding for both political parties. Former Congresswoman Cynthia McKinney has told how she was approached immediately she ran for office to 'sign the pledge' to Israel and confirm that she would always vote in that country's best interests. All American politicians are approached in this way. Anyone who refuses will get no support or funding from the enormous and all-powerful Zionist lobby that includes organisations like mega-lobby group AIPAC, the American Israel Public Affairs Committee. Trump's biggest funder was ultra-Zionist casino and media billionaire Sheldon Adelson while major funders of the Democratic Party include ultra-Zionist George Soros and ultra-Zionist financial and media mogul, Haim Saban. Some may reel back at the suggestion that Soros is an Israel-firster (Sabbatian-controlled Israel-firster), but Renegade Minds watch the actions not the words and everywhere Soros donates his billions the Sabbatian agenda benefits. In the spirit of Sabbatian inversion Soros pledged \$1 billion for a new university network to promote 'liberal values and tackle intolerance'. He made the announcement during his annual speech

at the Cult-owned World Economic Forum in Davos, Switzerland, in January, 2020, after his 'harsh criticism' of 'authoritarian rulers' around the world. You can only laugh at such brazen mendacity. How *he* doesn't laugh is the mystery. Translated from the Orwellian 'liberal values and tackle intolerance' means teaching non-white people to hate white people and for white people to loathe themselves for being born white. The reason for that will become clear.

### **The 'Anti-Semitism' fraud**

Zionists support the Jewish homeland in the land of Palestine which has been the Sabbatian-Rothschild goal for so long, but not for the benefit of Jews. Sabbatians and their global Anti-Semitism Industry have skewed public and political opinion to equate opposing the violent extremes of Zionism to be a blanket attack and condemnation of all Jewish people. Sabbatians and their global Anti-Semitism Industry have skewed public and political opinion to equate opposing the violent extremes of Zionism to be a blanket attack and condemnation of all Jewish people. This is nothing more than a Sabbatian protection racket to stop legitimate investigation and exposure of their agendas and activities. The official definition of 'anti-Semitism' has more recently been expanded to include criticism of Zionism – a *political movement* – and this was done to further stop exposure of Sabbatian infiltrators who created Zionism as we know it today in the 19th century. Renegade Minds will talk about these subjects when they know the shit that will come their way. People must decide if they want to know the truth or just cower in the corner in fear of what others will say. Sabbatians have been trying to label me as 'anti-Semitic' since the 1990s as I have uncovered more and more about their background and agendas. Useless, gutless, fraudulent 'journalists' then just repeat the smears without question and on the day I was writing this section a pair of unquestioning repeaters called Ben Quinn and Archie Bland (how appropriate) outright called me an 'anti-Semite' in the establishment propaganda sheet, the London *Guardian*, with no supporting evidence. The

Sabbatian Anti-Semitism Industry said so and who are they to question that? They wouldn't dare. Ironically 'Semitic' refers to a group of languages in the Middle East that are almost entirely Arabic. 'Anti-Semitism' becomes 'anti-Arab' which if the consequences of this misunderstanding were not so grave would be hilarious. Don't bother telling Quinn and Bland. I don't want to confuse them, bless 'em. One reason I am dubbed 'anti-Semitic' is that I wrote in the 1990s that Jewish operatives (Sabbatians) were heavily involved in the Russian Revolution when Sabbatians overthrew the Romanov dynasty. This apparently made me 'anti-Semitic'. Oh, really? Here is a section from *The Trigger*:

British journalist Robert Wilton confirmed these themes in his 1920 book *The Last Days of the Romanovs* when he studied official documents from the Russian government to identify the members of the Bolshevik ruling elite between 1917 and 1919. The Central Committee included 41 Jews among 62 members; the Council of the People's Commissars had 17 Jews out of 22 members; and 458 of the 556 most important Bolshevik positions between 1918 and 1919 were occupied by Jewish people. Only 17 were Russian. Then there were the 23 Jews among the 36 members of the vicious Cheka Soviet secret police established in 1917 who would soon appear all across the country.

Professor Robert Service of Oxford University, an expert on 20th century Russian history, found evidence that ['Jewish'] Leon Trotsky had sought to make sure that Jews were enrolled in the Red Army and were disproportionately represented in the Soviet civil bureaucracy that included the Cheka which performed mass arrests, imprisonment and executions of 'enemies of the people'. A US State Department Decimal File (861.00/5339) dated November 13th, 1918, names [Rothschild banking agent in America] Jacob Schiff and a list of ultra-Zionists as funders of the Russian Revolution leading to claims of a 'Jewish plot', but the key point missed by all is they were not 'Jews' – they were Sabbatian-Frankists.

Britain's Winston Churchill made the same error by mistake or otherwise. He wrote in a 1920 edition of the *Illustrated Sunday Herald* that those behind the Russian revolution were part of a 'worldwide conspiracy for the overthrow of civilisation and for the reconstitution of society on the basis of arrested development, of envious malevolence, and impossible equality' (see 'Woke' today because that has been created by the same network). Churchill said there was no need to exaggerate the part played in the creation of Bolshevism and in the actual bringing about of the Russian

Revolution 'by these international and for the most part atheistical Jews' ['atheistical Jews' = Sabbatians]. Churchill said it is certainly a very great one and probably outweighs all others: 'With the notable exception of Lenin, the majority of the leading figures are Jews.' He went on to describe, knowingly or not, the Sabbatian modus operandi of placing puppet leaders nominally in power while they control from the background:

Moreover, the principal inspiration and driving power comes from the Jewish leaders. Thus Tchitcherin, a pure Russian, is eclipsed by his nominal subordinate, Litvinoff, and the influence of Russians like Bukharin or Lunacharski cannot be compared with the power of Trotsky, or of Zinovieff, the Dictator of the Red Citadel (Petrograd), or of Krassin or Radek – all Jews. In the Soviet institutions the predominance of Jews is even more astonishing. And the prominent, if not indeed the principal, part in the system of terrorism applied by the Extraordinary Commissions for Combatting Counter-Revolution has been taken by Jews, and in some notable cases by Jewesses.

What I said about seriously disproportionate involvement in the Russian Revolution by Jewish 'revolutionaries' (Sabbatians) is provable fact, but truth is no defence against the Sabbatian Anti-Semitism Industry, its repeater parrots like Quinn and Bland, and the now breathtaking network of so-called 'Woke' 'anti-hate' groups with interlocking leaderships and funding which have the role of discrediting and silencing anyone who gets too close to exposing the Sabbatians. We have seen 'truth is no defence' confirmed in legal judgements with the Saskatchewan Human Rights Commission in Canada decreeing this: 'Truthful statements can be presented in a manner that would meet the definition of hate speech, and not all truthful statements must be free from restriction.' Most 'anti-hate' activists, who are themselves consumed by hatred, are too stupid and ignorant of the world to know how they are being used. They are far too far up their own virtue-signalling arses and it's far too dark for them to see anything.

## **The 'revolution' game**

The background and methods of the 'Russian' Revolution are straight from the Sabbatian playbook seen in the French Revolution

and endless others around the world that appear to start as a revolution of the people against tyrannical rule and end up with a regime change to more tyrannical rule overtly or covertly. Wars, terror attacks and regime overthrows follow the Sabbatian cult through history with its agents creating them as Problem-Reaction-Solutions to remove opposition on the road to world domination. Sabbatian dots connect the Rothschilds with the Illuminati, Jacobins of the French Revolution, the 'Bund' or League of the Just, the International Communist Party, Communist League and the Communist Manifesto of Karl Marx and Friedrich Engels that would lead to the Rothschild-funded Russian Revolution. The sequence comes under the heading of 'creative destruction' when you advance to your global goal by continually destroying the status quo to install a new status quo which you then also destroy. The two world wars come to mind. With each new status quo you move closer to your planned outcome. Wars and mass murder are to Sabbatians a collective blood sacrifice ritual. They are obsessed with death for many reasons and one is that death is an inversion of life. Satanists and Sabbatians are obsessed with death and often target churches and churchyards for their rituals. Inversion-obsessed Sabbatians explain the use of inverted symbolism including the *inverted* pentagram and *inverted* cross. The inversion of the cross has been related to targeting Christianity, but the cross was a religious symbol long before Christianity and its inversion is a statement about the Sabbatian mentality and goals more than any single religion.

Sabbatians operating in Germany were behind the rise of the occult-obsessed Nazis and the subsequent Jewish exodus from Germany and Europe to Palestine and the United States after World War Two. The Rothschild dynasty was at the forefront of this both as political manipulators and by funding the operation. Why would Sabbatians help to orchestrate the horrors inflicted on Jews by the Nazis and by Stalin after they organised the Russian Revolution? Sabbatians hate Jews and their religion, that's why. They pose as Jews and secure positions of control within Jewish society and play the 'anti-Semitism' card to protect themselves from exposure

through a global network of organisations answering to the Sabbatian-created-and-controlled globe-spanning intelligence network that involves a stunning web of military-intelligence operatives and operations for a tiny country of just nine million. Among them are Jewish assets who are not Sabbatians but have been convinced by them that what they are doing is for the good of Israel and the Jewish community to protect them from what they have been programmed since childhood to believe is a Jew-hating hostile world. The Jewish community is just a highly convenient cover to hide the true nature of Sabbatians. Anyone getting close to exposing their game is accused by Sabbatian place-people and gofers of 'anti-Semitism' and claiming that all Jews are part of a plot to take over the world. I am not saying that. I am saying that Sabbatians – the *real* Jew-haters – have infiltrated the Jewish community to use them both as a cover and an 'anti-Semitic' defence against exposure. Thus we have the Anti-Semitism Industry targeted researchers in this way and most Jewish people think this is justified and genuine. They don't know that their 'Jewish' leaders and institutions of state, intelligence and military are not controlled by Jews at all, but cultists and stooges of Sabbatian-Frankism. I once added my name to a pro-Jewish freedom petition online and the next time I looked my name was gone and text had been added to the petition blurb to attack me as an 'anti-Semite' such is the scale of perceptual programming.

## **Moving on America**

I tell the story in *The Trigger* and a chapter called 'Atlantic Crossing' how particularly after Israel was established the Sabbatians moved in on the United States and eventually grasped control of government administration, the political system via both Democrats and Republicans, the intelligence community like the CIA and National Security Agency (NSA), the Pentagon and mass media. Through this seriously compartmentalised network Sabbatians and their operatives in Mossad, Israeli Defense Forces (IDF) and US agencies pulled off 9/11 and blamed it on 19 'Al-Qaeda hijackers' dominated by men from, or connected to, Sabbatian-ruled Saudi

Arabia. The '19' were not even on the planes let alone flew those big passenger jets into buildings while being largely incompetent at piloting one-engine light aircraft. 'Hijacker' Hani Hanjour who is said to have flown American Airlines Flight 77 into the Pentagon with a turn and manoeuvre most professional pilots said they would have struggled to do was banned from renting a small plane by instructors at the Freeway Airport in Bowie, Maryland, just *six weeks* earlier on the grounds that he was an incompetent pilot. The Jewish population of the world is just 0.2 percent with even that almost entirely concentrated in Israel (75 percent Jewish) and the United States (around two percent). This two percent and globally 0.2 percent refers to *Jewish* people and not Sabbatian interlopers who are a fraction of that fraction. What a sobering thought when you think of the fantastic influence on world affairs of tiny Israel and that the Project for the New America Century (PNAC) which laid out the blueprint in September, 2000, for America's war on terror and regime change wars in Iraq, Libya and Syria was founded and dominated by Sabbatians known as 'Neocons'. The document conceded that this plan would not be supported politically or publicly without a major attack on American soil and a Problem-Reaction-Solution excuse to send troops to war across the Middle East. Sabbatian Neocons said:

... [The] process of transformation ... [war and regime change] ... is likely to be a long one, absent some catastrophic and catalysing event – like a new Pearl Harbor.

Four months later many of those who produced that document came to power with their inane puppet George Bush from the long-time Sabbatian Bush family. They included Sabbatian Dick Cheney who was officially vice-president, but really de-facto president for the entirety of the 'Bush' government. Nine months after the 'Bush' inauguration came what Bush called at the time 'the Pearl Harbor of the 21st century' and with typical Sabbatian timing and symbolism 2001 was the 60th anniversary of the attack in 1941 by the Japanese Air Force on Pearl Harbor, Hawaii, which allowed President Franklin Delano Roosevelt to take the United States into a Sabbatian-

instigated Second World War that he said in his election campaign that he never would. The evidence is overwhelming that Roosevelt and his military and intelligence networks knew the attack was coming and did nothing to stop it, but they did make sure that America's most essential naval ships were not in Hawaii at the time. Three thousand Americans died in the Pearl Harbor attacks as they did on September 11th. By the 9/11 year of 2001 Sabbatians had widely infiltrated the US government, military and intelligence operations and used their compartmentalised assets to pull off the 'Al-Qaeda' attacks. If you read *The Trigger* it will blow your mind to see the utterly staggering concentration of 'Jewish' operatives (Sabbatian infiltrators) in essential positions of political, security, legal, law enforcement, financial and business power before, during, and after the attacks to make them happen, carry them out, and then cover their tracks – and I do mean *staggering* when you think of that 0.2 percent of the world population and two percent of Americans which are Jewish while Sabbatian infiltrators are a fraction of that. A central foundation of the 9/11 conspiracy was the hijacking of government, military, Air Force and intelligence computer systems in real time through 'back-door' access made possible by Israeli (Sabbatian) 'cyber security' software. Sabbatian-controlled Israel is on the way to rivalling Silicon Valley for domination of cyberspace and is becoming the dominant force in cyber-security which gives them access to entire computer systems and their passcodes across the world. Then add to this that Zionists head (officially) Silicon Valley giants like Google (Larry Page and Sergey Brin), Google-owned YouTube (Susan Wojcicki), Facebook (Mark Zuckerberg and Sheryl Sandberg), and Apple (Chairman Arthur D. Levinson), and that ultra-Zionist hedge fund billionaire Paul Singer has a \$1 billion stake in Twitter which is only nominally headed by 'CEO' pothead Jack Dorsey. As cable news host Tucker Carlson said of Dorsey: 'There used to be debate in the medical community whether dropping a ton of acid had permanent effects and I think that debate has now ended.' Carlson made the comment after Dorsey told a hearing on Capitol Hill (if you cut through his bullshit) that he



believed in free speech so long as he got to decide what you can hear and see. These 'big names' of Silicon Valley are only front men and women for the Global Cult, not least the Sabbatians, who are the true controllers of these corporations. Does anyone still wonder why these same people and companies have been ferociously censoring and banning people (like me) for exposing any aspect of the Cult agenda and especially the truth about the 'Covid' hoax which Sabbatians have orchestrated?

The Jeffrey Epstein paedophile ring was a Sabbatian operation. He was officially 'Jewish' but he was a Sabbatian and women abused by the ring have told me about the high number of 'Jewish' people involved. The Epstein horror has Sabbatian written all over it and matches perfectly their modus operandi and obsession with sex and ritual. Epstein was running a Sabbatian blackmail ring in which famous people with political and other influence were provided with young girls for sex while everything was being filmed and recorded on hidden cameras and microphones at his New York house, Caribbean island and other properties. Epstein survivors have described this surveillance system to me and some have gone public. Once the famous politician or other figure knew he or she was on video they tended to do whatever they were told. Here we go again ...when you've got them by the balls their hearts and minds will follow. Sabbatians use this blackmail technique on a wide scale across the world to entrap politicians and others they need to act as demanded. Epstein's private plane, the infamous 'Lolita Express', had many well-known passengers including Bill Clinton while Bill Gates has flown on an Epstein plane and met with him four years after Epstein had been jailed for paedophilia. They subsequently met many times at Epstein's home in New York according to a witness who was there. Epstein's infamous side-kick was Ghislaine Maxwell, daughter of Mossad agent and ultra-Zionist mega-crooked British businessman, Bob Maxwell, who at one time owned the *Daily Mirror* newspaper. Maxwell was murdered at sea on his boat in 1991 by Sabbatian-controlled Mossad when he became a liability with his

business empire collapsing as a former Mossad operative has confirmed (see *The Trigger*).

### **Money, money, money, funny money ...**

Before I come to the Sabbatian connection with the last three US presidents I will lay out the crucial importance to Sabbatians of controlling banking and finance. Sabbatian Mayer Amschel Rothschild set out to dominate this arena in his family's quest for total global control. What is freedom? It is, in effect, choice. The more choices you have the freer you are and the fewer your choices the more you are enslaved. In the global structure created over centuries by Sabbatians the biggest decider and restrictor of choice is ... money. Across the world if you ask people what they would like to do with their lives and why they are not doing that they will reply 'I don't have the money'. This is the idea. A global elite of multi-billionaires are described as 'greedy' and that is true on one level; but control of money – who has it and who doesn't – is not primarily about greed. It's about control. Sabbatians have seized ever more control of finance and sucked the wealth of the world out of the hands of the population. We talk now, after all, about the 'One-percent' and even then the wealthiest are a lot fewer even than that. This has been made possible by a money scam so outrageous and so vast it could rightly be called the scam of scams founded on creating 'money' out of nothing and 'loaning' that with interest to the population. Money out of nothing is called 'credit'. Sabbatians have asserted control over governments and banking ever more completely through the centuries and secured financial laws that allow banks to lend hugely more than they have on deposit in a confidence trick known as fractional reserve lending. Imagine if you could lend money that doesn't exist and charge the recipient interest for doing so. You would end up in jail. Bankers by contrast end up in mansions, private jets, Malibu and Monaco.

Banks are only required to keep a fraction of their deposits and wealth in their vaults and they are allowed to lend 'money' they don't have called 'credit'. Go into a bank for a loan and if you succeed

the banker will not move any real wealth into your account. They will type into your account the amount of the agreed 'loan' – say £100,000. This is not wealth that really exists; it is non-existent, fresh-air, created-out-of-nothing 'credit' which has never, does not, and will never exist except in theory. Credit is backed by nothing except wind and only has buying power because people think that it has buying power and accept it in return for property, goods and services. I have described this situation as like those cartoon characters you see chasing each other and when they run over the edge of a cliff they keep running forward on fresh air until one of them looks down, realises what's happened, and they all crash into the ravine. The whole foundation of the Sabbatian financial system is to stop people looking down except for periodic moments when they want to crash the system (as in 2008 and 2020 ongoing) and reap the rewards from all the property, businesses and wealth their borrowers had signed over as 'collateral' in return for a 'loan' of fresh air. Most people think that money is somehow created by governments when it comes into existence from the start as a debt through banks 'lending' illusory money called credit. Yes, the very currency of exchange is a *debt* from day one issued as an interest-bearing loan. Why don't governments create money interest-free and lend it to their people interest-free? Governments are controlled by Sabbatians and the financial system is controlled by Sabbatians for whom interest-free money would be a nightmare come true. Sabbatians underpin their financial domination through their global network of central banks, including the privately-owned US Federal Reserve and Britain's Bank of England, and this is orchestrated by a privately-owned central bank coordination body called the Bank for International Settlements in Basle, Switzerland, created by the usual suspects including the Rockefellers and Rothschilds. Central bank chiefs don't answer to governments or the people. They answer to the Bank for International Settlements or, in other words, the Global Cult which is dominated today by Sabbatians.

## **Built-in disaster**

There are so many constituent scams within the overall banking scam. When you take out a loan of thin-air credit only the amount of that loan is theoretically brought into circulation to add to the amount in circulation; but you are paying back the principle plus interest. The additional interest is not created and this means that with every 'loan' there is a shortfall in the money in circulation between what is borrowed and what has to be paid back. There is never even close to enough money in circulation to repay all outstanding public and private debt including interest. Coldly weaved in the very fabric of the system is the certainty that some will lose their homes, businesses and possessions to the banking 'lender'. This is less obvious in times of 'boom' when the amount of money in circulation (and the debt) is expanding through more people wanting and getting loans. When a downturn comes and the money supply contracts it becomes painfully obvious that there is not enough money to service all debt and interest. This is less obvious in times of 'boom' when the amount of money in circulation (and the debt) is expanding through more people wanting and getting loans. When a downturn comes and the money supply contracts and it becomes painfully obvious – as in 2008 and currently – that there is not enough money to service all debt and interest. Sabbatian banksters have been leading the human population through a calculated series of booms (more debt incurred) and busts (when the debt can't be repaid and the banks get the debtor's tangible wealth in exchange for non-existent 'credit'). With each 'bust' Sabbatian bankers have absorbed more of the world's tangible wealth and we end up with the One-percent. Governments are in bankruptcy levels of debt to the same system and are therefore owned by a system they do not control. The Federal Reserve, 'America's central bank', is privately-owned and American presidents only nominally appoint its chairman or woman to maintain the illusion that it's an arm of government. It's not. The 'Fed' is a cartel of private banks which handed billions to its associates and friends after the crash of 2008 and has been Sabbatian-controlled since it was manipulated into being in 1913 through the covert trickery of Rothschild banking agents Jacob Schiff and Paul

Warburg, and the Sabbatian Rockefeller family. Somehow from a Jewish population of two-percent and globally 0.2 percent (Sabbatian interlopers remember are far smaller) ultra-Zionists headed the Federal Reserve for 31 years between 1987 and 2018 in the form of Alan Greenspan, Bernard Bernanke and Janet Yellen (now Biden's Treasury Secretary) with Yellen's deputy chairman a Israeli-American dual citizen and ultra-Zionist Stanley Fischer, a former governor of the Bank of Israel. Ultra-Zionist Fed chiefs spanned the presidencies of Ronald Reagan ('Republican'), Father George Bush ('Republican'), Bill Clinton ('Democrat'), Boy George Bush ('Republican') and Barack Obama ('Democrat'). We should really add the pre-Greenspan chairman, Paul Adolph Volcker, 'appointed' by Jimmy Carter ('Democrat') who ran the Fed between 1979 and 1987 during the Carter and Reagan administrations before Greenspan took over. Volcker was a long-time associate and business partner of the Rothschilds. No matter what the 'party' officially in power the United States economy was directed by the same force. Here are members of the Obama, Trump and Biden administrations and see if you can make out a common theme.

### **Barack Obama ('Democrat')**

Ultra-Zionists Robert Rubin, Larry Summers, and Timothy Geithner ran the US Treasury in the Clinton administration and two of them reappeared with Obama. Ultra-Zionist Fed chairman Alan Greenspan had manipulated the crash of 2008 through deregulation and jumped ship just before the disaster to make way for ultra-Zionist Bernard Bernanke to hand out trillions to Sabbatian 'too big to fail' banks and businesses, including the ubiquitous ultra-Zionist Goldman Sachs which has an ongoing revolving door operation between itself and major financial positions in government worldwide. Obama inherited the fallout of the crash when he took office in January, 2009, and fortunately he had the support of his ultra-Zionist White House Chief of Staff Rahm Emmanuel, son of a terrorist who helped to bomb Israel into being in 1948, and his ultra-Zionist senior adviser David Axelrod, chief strategist in Obama's two

successful presidential campaigns. Emmanuel, later mayor of Chicago and former senior fundraiser and strategist for Bill Clinton, is an example of the Sabbatian policy after Israel was established of migrating insider families to America so their children would be born American citizens. 'Obama' chose this financial team throughout his administration to respond to the Sabbatian-instigated crisis:

Timothy Geithner (ultra-Zionist) Treasury Secretary; Jacob J. Lew, Treasury Secretary; Larry Summers (ultra-Zionist), director of the White House National Economic Council; Paul Adolph Volcker (Rothschild business partner), chairman of the Economic Recovery Advisory Board; Peter Orszag (ultra-Zionist), director of the Office of Management and Budget overseeing all government spending; Penny Pritzker (ultra-Zionist), Commerce Secretary; Jared Bernstein (ultra-Zionist), chief economist and economic policy adviser to Vice President Joe Biden; Mary Schapiro (ultra-Zionist), chair of the Securities and Exchange Commission (SEC); Gary Gensler (ultra-Zionist), chairman of the Commodity Futures Trading Commission (CFTC); Sheila Bair (ultra-Zionist), chair of the Federal Deposit Insurance Corporation (FDIC); Karen Mills (ultra-Zionist), head of the Small Business Administration (SBA); Kenneth Feinberg (ultra-Zionist), Special Master for Executive [bail-out] Compensation. Feinberg would be appointed to oversee compensation (with strings) to 9/11 victims and families in a campaign to stop them having their day in court to question the official story. At the same time ultra-Zionist Bernard Bernanke was chairman of the Federal Reserve and these are only some of the ultra-Zionists with allegiance to Sabbatian-controlled Israel in the Obama government. Obama's biggest corporate donor was ultra-Zionist Goldman Sachs which had employed many in his administration.

### **Donald Trump ('Republican')**

Trump claimed to be an outsider (he wasn't) who had come to 'drain the swamp'. He embarked on this goal by immediately appointing ultra-Zionist Steve Mnuchin, a Goldman Sachs employee for 17

years, as his Treasury Secretary. Others included Gary Cohn (ultra-Zionist), chief operating officer of Goldman Sachs, his first Director of the National Economic Council and chief economic adviser, who was later replaced by Larry Kudlow (ultra-Zionist). Trump's senior adviser throughout his four years in the White House was his sinister son-in-law Jared Kushner, a life-long friend of Israel Prime Minister Benjamin Netanyahu. Kushner is the son of a convicted crook who was pardoned by Trump in his last days in office. Other ultra-Zionists in the Trump administration included: Stephen Miller, Senior Policy Adviser; Avrahm Berkowitz, Deputy Adviser to Trump and his Senior Adviser Jared Kushner; Ivanka Trump, Adviser to the President, who converted to Judaism when she married Jared Kushner; David Friedman, Trump lawyer and Ambassador to Israel; Jason Greenblatt, Trump Organization executive vice president and chief legal officer, who was made Special Representative for International Negotiations and the Israeli-Palestinian Conflict; Rod Rosenstein, Deputy Attorney General; Elliot Abrams, Special Representative for Venezuela, then Iran; John Eisenberg, National Security Council Legal Adviser and Deputy Council to the President for National Security Affairs; Anne Neuberger, Deputy National Manager, National Security Agency; Ezra Cohen-Watnick, Acting Under Secretary of Defense for Intelligence; Elan Carr, Special Envoy to monitor and combat anti-Semitism; Len Khodorkovsky, Deputy Special Envoy to monitor and combat anti-Semitism; Reed Cordish, Assistant to the President, Intragovernmental and Technology Initiatives. Trump Vice President Mike Pence and Secretary of State Mike Pompeo, both Christian Zionists, were also vehement supporters of Israel and its goals and ambitions.

Donald 'free-speech believer' Trump pardoned a number of financial and violent criminals while ignoring calls to pardon Julian Assange and Edward Snowden whose crimes are revealing highly relevant information about government manipulation and corruption and the widespread illegal surveillance of the American people by US 'security' agencies. It's so good to know that Trump is on the side of freedom and justice and not mega-criminals with

allegiance to Sabbatian-controlled Israel. These included a pardon for Israeli spy Jonathan Pollard who was jailed for life in 1987 under the Espionage Act. Aviem Sella, the Mossad agent who recruited Pollard, was also pardoned by Trump while Assange sat in jail and Snowden remained in exile in Russia. Sella had 'fled' (was helped to escape) to Israel in 1987 and was never extradited despite being charged under the Espionage Act. A Trump White House statement said that Sella's clemency had been 'supported by Benjamin Netanyahu, Ron Dermer, Israel's US Ambassador, David Friedman, US Ambassador to Israel and Miriam Adelson, wife of leading Trump donor Sheldon Adelson who died shortly before. Other friends of Jared Kushner were pardoned along with Sholom Weiss who was believed to be serving the longest-ever white-collar prison sentence of more than 800 years in 2000. The sentence was commuted of Ponzi-schemer Eliyahu Weinstein who defrauded Jews and others out of \$200 million. I did mention that Assange and Snowden were ignored, right? Trump gave Sabbatians almost everything they asked for in military and political support, moving the US Embassy from Tel Aviv to Jerusalem with its critical symbolic and literal implications for Palestinian statehood, and the 'deal of the Century' designed by Jared Kushner and David Friedman which gave the Sabbatian Israeli government the green light to substantially expand its already widespread program of building illegal Jewish-only settlements in the occupied land of the West Bank. This made a two-state 'solution' impossible by seizing all the land of a potential Palestinian homeland and that had been the plan since 1948 and then 1967 when the Arab-controlled Gaza Strip, West Bank, Sinai Peninsula and Syrian Golan Heights were occupied by Israel. All the talks about talks and road maps and delays have been buying time until the West Bank was physically occupied by Israeli real estate. Trump would have to be a monumentally ill-informed idiot not to see that this was the plan he was helping to complete. The Trump administration was in so many ways the Kushner administration which means the Netanyahu administration which means the Sabbatian administration. I understand why many opposing Cult fascism in all its forms gravitated to Trump, but he



was a crucial part of the Sabbatian plan and I will deal with this in the next chapter.

## **Joe Biden ('Democrat')**

A barely cognitive Joe Biden took over the presidency in January, 2021, along with his fellow empty shell, Vice-President Kamala Harris, as the latest Sabbatian gofers to enter the White House. Names on the door may have changed and the 'party' – the force behind them remained the same as Zionists were appointed to a stream of pivotal areas relating to Sabbatian plans and policy. They included: Janet Yellen, Treasury Secretary, former head of the Federal Reserve, and still another ultra-Zionist running the US Treasury after Mnuchin (Trump), Lew and Geithner (Obama), and Summers and Rubin (Clinton); Anthony Blinken, Secretary of State; Wendy Sherman, Deputy Secretary of State (so that's 'Biden's' Sabbatian foreign policy sorted); Jeff Zients, White House coronavirus coordinator; Rochelle Walensky, head of the Centers for Disease Control; Rachel Levine, transgender deputy health secretary (that's 'Covid' hoax policy under control); Merrick Garland, Attorney General; Alejandro Mayorkas, Secretary of Homeland Security; Cass Sunstein, Homeland Security with responsibility for new immigration laws; Avril Haines, Director of National Intelligence; Anne Neuberger, National Security Agency cybersecurity director (note, cybersecurity); David Cohen, CIA Deputy Director; Ronald Klain, Biden's Chief of Staff (see Rahm Emanuel); Eric Lander, a 'leading geneticist', Office of Science and Technology Policy director (see Smart Grid, synthetic biology agenda); Jessica Rosenworcel, acting head of the Federal Communications Commission (FCC) which controls Smart Grid technology policy and electromagnetic communication systems including 5G. How can it be that so many pivotal positions are held by two-percent of the American population and 0.2 percent of the world population administration after administration no matter who is the president and what is the party? It's a coincidence? Of course it's not and this is why Sabbatians have built their colossal global web of interlocking 'anti-

hate' hate groups to condemn anyone who asks these glaring questions as an 'anti-Semite'. The way that Jewish people horrifically abused in Sabbatian-backed Nazi Germany are exploited to this end is stomach-turning and disgusting beyond words.

## **Political fusion**

Sabbatian manipulation has reversed the roles of Republicans and Democrats and the same has happened in Britain with the Conservative and Labour Parties. Republicans and Conservatives were always labelled the 'right' and Democrats and Labour the 'left', but look at the policy positions now and the Democrat-Labour 'left' has moved further to the 'right' than Republicans and Conservatives under the banner of 'Woke', the Cult-created far-right tyranny. Where once the Democrat-Labour 'left' defended free speech and human rights they now seek to delete them and as I said earlier despite the 'Covid' fascism of the Jackboot Johnson Conservative government in the UK the Labour Party of leader Keir Starmer demanded even more extreme measures. The Labour Party has been very publicly absorbed by Sabbatians after a political and media onslaught against the previous leader, the weak and inept Jeremy Corbyn, over made-up allegations of 'anti-Semitism' both by him and his party. The plan was clear with this 'anti-Semite' propaganda and what was required in response was a swift and decisive 'fuck off' from Corbyn and a statement to expose the Anti-Semitism Industry (Sabbatian) attempt to silence Labour criticism of the Israeli government (Sabbatians) and purge the party of all dissent against the extremes of ultra-Zionism (Sabbatians). Instead Corbyn and his party fell to their knees and appeased the abusers which, by definition, is impossible. Appeasing one demand leads only to a new demand to be appeased until takeover is complete. Like I say – 'fuck off' would have been a much more effective policy and I have used it myself with great effect over the years when Sabbatians are on my case which is most of the time. I consider that fact a great compliment, by the way. The outcome of the Labour Party capitulation is that we now have a Sabbatian-controlled

Conservative Party 'opposed' by a Sabbatian-controlled Labour Party in a one-party Sabbatian state that hurtles towards the extremes of tyranny (the Sabbatian cult agenda). In America the situation is the same. Labour's Keir Starmer spends his days on his knees with his tongue out pointing to Tel Aviv, or I guess now Jerusalem, while Boris Johnson has an 'anti-Semitism czar' in the form of former Labour MP John Mann who keeps Starmer company on his prayer mat.

Sabbatian influence can be seen in Jewish members of the Labour Party who have been ejected for criticism of Israel including those from families that suffered in Nazi Germany. Sabbatians despise real Jewish people and target them even more harshly because it is so much more difficult to dub them 'anti-Semitic' although in their desperation they do try.

## CHAPTER THREE

### **The Pushbacker sting**

*Until you realize how easy it is for your mind to be manipulated, you remain the puppet of someone else's game*

Evita Ochel

I will use the presidencies of Trump and Biden to show how the manipulation of the one-party state plays out behind the illusion of political choice across the world. No two presidencies could – on the face of it – be more different and apparently at odds in terms of direction and policy.

A Renegade Mind sees beyond the obvious and focuses on outcomes and consequences and not image, words and waffle. The Cult embarked on a campaign to divide America between those who blindly support its agenda (the mentality known as 'Woke') and those who are pushing back on where the Cult and its Sabbatians want to go. This presents infinite possibilities for dividing and ruling the population by setting them at war with each other and allows a perceptual ring fence of demonisation to encircle the Pushbackers in a modern version of the Little Big Horn in 1876 when American cavalry led by Lieutenant Colonel George Custer were drawn into a trap, surrounded and killed by Native American tribes defending their land of thousands of years from being seized by the government. In this modern version the roles are reversed and it's those defending themselves from the Sabbatian government who are surrounded and the government that's seeking to destroy them. This trap was set years ago and to explain how we must return to 2016

and the emergence of Donald Trump as a candidate to be President of the United States. He set out to overcome the best part of 20 other candidates in the Republican Party before and during the primaries and was not considered by many in those early stages to have a prayer of living in the White House. The Republican Party was said to have great reservations about Trump and yet somehow he won the nomination. When you know how American politics works – politics in general – there is no way that Trump could have become the party's candidate unless the Sabbatian-controlled 'Neocons' that run the Republican Party wanted that to happen. We saw the proof in emails and documents made public by WikiLeaks that the Democratic Party hierarchy, or Democons, systematically undermined the campaign of Bernie Sanders to make sure that Sabbatian gofer Hillary Clinton won the nomination to be their presidential candidate. If the Democons could do that then the Neocons in the Republican Party could have derailed Trump in the same way. But they didn't and at that stage I began to conclude that Trump could well be the one chosen to be president. If that was the case the 'why' was pretty clear to see – the goal of dividing America between Cult agenda-supporting Wokers and Pushbackers who gravitated to Trump because he was telling them what they wanted to hear. His constituency of support had been increasingly ignored and voiceless for decades and profoundly through the eight years of Sabbatian puppet Barack Obama. Now here was someone speaking their language of pulling back from the incessant globalisation of political and economic power, the exporting of American jobs to China and elsewhere by 'American' (Sabbatian) corporations, the deletion of free speech, and the mass immigration policies that had further devastated job opportunities for the urban working class of all races and the once American heartlands of the Midwest.

### **Beware the forked tongue**

Those people collectively sighed with relief that at last a political leader was apparently on their side, but another trait of the Renegade Mind is that you look even harder at people telling you

what you want to hear than those who are telling you otherwise. Obviously as I said earlier people wish what they want to hear to be true and genuine and they are much more likely to believe that than someone saying what they don't want to hear and don't want to be true. Sales people are taught to be skilled in eliciting by calculated questioning what their customers want to hear and repeating that back to them as their own opinion to get their targets to like and trust them. Assets of the Cult are also sales people in the sense of selling perception. To read Cult manipulation you have to play the long and expanded game and not fall for the Vaudeville show of party politics. Both American parties are vehicles for the Cult and they exploit them in different ways depending on what the agenda requires at that moment. Trump and the Republicans were used to be the focus of dividing America and isolating Pushbackers to open the way for a Biden presidency to become the most extreme in American history by advancing the full-blown Woke (Cult) agenda with the aim of destroying and silencing Pushbackers now labelled Nazi Trump supporters and white supremacists.

Sabbatians wanted Trump in office for the reasons described by ultra-Zionist Saul Alinsky (1909-1972) who was promoting the Woke philosophy through 'community organising' long before anyone had heard of it. In those days it still went by its traditional name of Marxism. The reason for the manipulated Trump phenomenon was laid out in Alinsky's 1971 book, *Rules for Radicals*, which was his blueprint for overthrowing democratic and other regimes and replacing them with Sabbatian Marxism. Not surprisingly his to-do list was evident in the Sabbatian French and Russian 'Revolutions' and that in China which will become very relevant in the next chapter about the 'Covid' hoax. Among Alinsky's followers have been the deeply corrupt Barack Obama, House Speaker Nancy Pelosi and Hillary Clinton who described him as a 'hero'. All three are Sabbatian stooges with Pelosi personifying the arrogant corrupt idiocy that so widely fronts up for the Cult inner core. Predictably as a Sabbatian advocate of the 'light-bringer' Alinsky features Lucifer on the dedication page of his book as the original radical who gained

his own kingdom ('Earth' as we shall see). One of Alinsky's golden radical rules was to pick an individual and focus all attention, hatred and blame on them and not to target faceless bureaucracies and corporations. *Rules for Radicals* is really a Sabbatian handbook with its contents repeatedly employed all over the world for centuries and why wouldn't Sabbatians bring to power their designer-villain to be used as the individual on which all attention, hatred and blame was bestowed? This is what they did and the only question for me is how much Trump knew that and how much he was manipulated. A bit of both, I suspect. This was Alinsky's Trump technique from a man who died in 1972. The technique has spanned history:

Pick the target, freeze it, personalize it, polarize it. Don't try to attack abstract corporations or bureaucracies. Identify a responsible individual. Ignore attempts to shift or spread the blame.

From the moment Trump came to illusory power everything was about him. It wasn't about Republican policy or opinion, but all about Trump. Everything he did was presented in negative, derogatory and abusive terms by the Sabbatian-dominated media led by Cult operations such as CNN, MSNBC, *The New York Times* and the Jeff Bezos-owned *Washington Post* – 'Pick the target, freeze it, personalize it, polarize it.' Trump was turned into a demon to be vilified by those who hated him and a demi-god loved by those who worshipped him. This, in turn, had his supporters, too, presented as equally demonic in preparation for the punchline later down the line when Biden was about to take office. It was here's a Trump, there's a Trump, everywhere a Trump, Trump. Virtually every news story or happening was filtered through the lens of 'The Donald'. You loved him or hated him and which one you chose was said to define you as Satan's spawn or a paragon of virtue. Even supporting some Trump policies or statements and not others was enough for an assault on your character. No shades of grey were or are allowed. Everything is black and white (literally and figuratively). A Californian I knew had her head utterly scrambled by her hatred for Trump while telling people they should love each other. She was so totally consumed by

Trump Derangement Syndrome as it became to be known that this glaring contradiction would never have occurred to her. By definition anyone who criticised Trump or praised his opponents was a hero and this lady described Joe Biden as 'a kind, honest gentleman' when he's a provable liar, mega-crook and vicious piece of work to boot. Sabbatians had indeed divided America using Trump as the fall-guy and all along the clock was ticking on the consequences for his supporters.

### **In hock to his masters**

Trump gave Sabbatians via Israel almost everything they wanted in his four years. Ask and you shall receive was the dynamic between himself and Benjamin Netanyahu orchestrated by Trump's ultra-Zionist son-in-law Jared Kushner, his ultra-Zionist Ambassador to Israel, David Friedman, and ultra-Zionist 'Israel adviser', Jason Greenblatt. The last two were central to the running and protecting from collapse of his business empire, the Trump Organisation, and colossal business failures made him forever beholding to Sabbatian networks that bailed him out. By the start of the 1990s Trump owed \$4 billion to banks that he couldn't pay and almost \$1 billion of that was down to him personally and not his companies. This mega-disaster was the result of building two new casinos in Atlantic City and buying the enormous Taj Mahal operation which led to crippling debt payments. He had borrowed fantastic sums from 72 banks with major Sabbatian connections and although the scale of debt should have had him living in a tent alongside the highway they never foreclosed. A plan was devised to lift Trump from the mire by BT Securities Corporation and Rothschild Inc. and the case was handled by Wilber Ross who had worked for the Rothschilds for 27 years. Ross would be named US Commerce Secretary after Trump's election. Another crucial figure in saving Trump was ultra-Zionist 'investor' Carl Icahn who bought the Taj Mahal casino. Icahn was made special economic adviser on financial regulation in the Trump administration. He didn't stay long but still managed to find time to make a tidy sum of a reported \$31.3 million when he sold his



holdings affected by the price of steel three days before Trump imposed a 235 percent tariff on steel imports. What amazing bits of luck these people have. Trump and Sabbatian operatives have long had a close association and his mentor and legal adviser from the early 1970s until 1986 was the dark and genetically corrupt ultra-Zionist Roy Cohn who was chief counsel to Senator Joseph McCarthy's 'communist' witch-hunt in the 1950s. *Esquire* magazine published an article about Cohn with the headline 'Don't mess with Roy Cohn'. He was described as the most feared lawyer in New York and 'a ruthless master of dirty tricks ... [with] ... more than one Mafia Don on speed dial'. Cohn's influence, contacts, support and protection made Trump a front man for Sabbatians in New York with their connections to one of Cohn's many criminal employers, the 'Russian' Sabbatian Mafia. Israel-centric media mogul Rupert Murdoch was introduced to Trump by Cohn and they started a long friendship. Cohn died in 1986 weeks after being disbarred for unethical conduct by the Appellate Division of the New York State Supreme Court. The wheels of justice do indeed run slow given the length of Cohn's crooked career.

## **QAnon-sense**

We are asked to believe that Donald Trump with his fundamental connections to Sabbatian networks and operatives has been leading the fight to stop the Sabbatian agenda for the fascistic control of America and the world. Sure he has. A man entrapped during his years in the White House by Sabbatian operatives and whose biggest financial donor was casino billionaire Sheldon Adelson who was Sabbatian to his DNA?? Oh, do come on. Trump has been used to divide America and isolate Pushbackers on the Cult agenda under the heading of 'Trump supporters', 'insurrectionists' and 'white supremacists'. The US Intelligence/Mossad Psyop or psychological operation known as QAnon emerged during the Trump years as a central pillar in the Sabbatian campaign to lead Pushbackers into the trap set by those that wished to destroy them. I knew from the start that QAnon was a scam because I had seen the same scenario many

times before over 30 years under different names and I had written about one in particular in the books. 'Not again' was my reaction when QAnon came to the fore. The same script is pulled out every few years and a new name added to the letterhead. The story always takes the same form: 'Insiders' or 'the good guys' in the government-intelligence-military 'Deep State' apparatus were going to instigate mass arrests of the 'bad guys' which would include the Rockefellers, Rothschilds, Barack Obama, Hillary Clinton, George Soros, etc., etc. Dates are given for when the 'good guys' are going to move in, but the dates pass without incident and new dates are given which pass without incident. The central message to Pushbackers in each case is that they don't have to do anything because there is 'a plan' and it is all going to be sorted by the 'good guys' on the inside. 'Trust the plan' was a QAnon mantra when the only plan was to misdirect Pushbackers into putting their trust in a Psyop they believed to be real. Beware, beware, those who tell you what you want to hear and always check it out. Right up to Biden's inauguration QAnon was still claiming that 'the Storm' was coming and Trump would stay on as president when Biden and his cronies were arrested and jailed. It was never going to happen and of course it didn't, but what did happen as a result provided that punchline to the Sabbatian Trump/QAnon Psyop.

On January 6th, 2021, a very big crowd of Trump supporters gathered in the National Mall in Washington DC down from the Capitol Building to protest at what they believed to be widespread corruption and vote fraud that stopped Trump being re-elected for a second term as president in November, 2020. I say as someone that does not support Trump or Biden that the evidence is clear that major vote-fixing went on to favour Biden, a man with cognitive problems so advanced he can often hardly string a sentence together without reading the words written for him on the Teleprompter. Glaring ballot discrepancies included serious questions about electronic voting machines that make vote rigging a comparative cinch and hundreds of thousands of paper votes that suddenly appeared during already advanced vote counts and virtually all of

them for Biden. Early Trump leads in crucial swing states suddenly began to close and disappear. The pandemic hoax was used as the excuse to issue almost limitless numbers of mail-in ballots with no checks to establish that the recipients were still alive or lived at that address. They were sent to streams of people who had not even asked for them. Private organisations were employed to gather these ballots and who knows what they did with them before they turned up at the counts. The American election system has been manipulated over decades to become a sick joke with more holes than a Swiss cheese for the express purpose of dictating the results. Then there was the criminal manipulation of information by Sabbatian tech giants like Facebook, Twitter and Google-owned YouTube which deleted pro-Trump, anti-Biden accounts and posts while everything in support of Biden was left alone. Sabbatians wanted Biden to win because after the dividing of America it was time for full-on Woke and every aspect of the Cult agenda to be unleashed.

### **Hunter gatherer**

Extreme Silicon Valley bias included blocking information by the *New York Post* exposing a Biden scandal that should have ended his bid for president in the final weeks of the campaign. Hunter Biden, his monumentally corrupt son, is reported to have sent a laptop to be repaired at a local store and failed to return for it. Time passed until the laptop became the property of the store for non-payment of the bill. When the owner saw what was on the hard drive he gave a copy to the FBI who did nothing even though it confirmed widespread corruption in which the Joe Biden family were using his political position, especially when he was vice president to Obama, to make multiple millions in countries around the world and most notably Ukraine and China. Hunter Biden's one-time business partner Tony Bobulinski went public when the story broke in the *New York Post* to confirm the corruption he saw and that Joe Biden not only knew what was going on he also profited from the spoils. Millions were handed over by a Chinese company with close

connections – like all major businesses in China – to the Chinese communist party of President Xi Jinping. Joe Biden even boasted at a meeting of the Cult's World Economic Forum that as vice president he had ordered the government of Ukraine to fire a prosecutor. What he didn't mention was that the same man just happened to be investigating an energy company which was part of Hunter Biden's corrupt portfolio. The company was paying him big bucks for no other reason than the influence his father had. Overnight Biden's presidential campaign should have been over given that he had lied publicly about not knowing what his son was doing. Instead almost the entire Sabbatian-owned mainstream media and Sabbatian-owned Silicon Valley suppressed circulation of the story. This alone went a mighty way to rigging the election of 2020. Cult assets like Mark Zuckerberg at Facebook also spent hundreds of millions to be used in support of Biden and vote 'administration'.

The Cult had used Trump as the focus to divide America and was now desperate to bring in moronic, pliable, corrupt Biden to complete the double-whammy. No way were they going to let little things like the will of the people thwart their plan. Silicon Valley widely censored claims that the election was rigged because it *was* rigged. For the same reason anyone claiming it was rigged was denounced as a 'white supremacist' including the pathetically few Republican politicians willing to say so. Right across the media where the claim was mentioned it was described as a 'false claim' even though these excuses for 'journalists' would have done no research into the subject whatsoever. Trump won seven million more votes than any sitting president had ever achieved while somehow a cognitively-challenged soon to be 78-year-old who was hidden away from the public for most of the campaign managed to win more votes than any presidential candidate in history. It makes no sense. You only had to see election rallies for both candidates to witness the enthusiasm for Trump and the apathy for Biden. Tens of thousands would attend Trump events while Biden was speaking in empty car parks with often only television crews attending and framing their shots to hide the fact that no one was there. It was pathetic to see

footage come to light of Biden standing at a podium making speeches only to TV crews and party fixers while reading the words written for him on massive Teleprompter screens. So, yes, those protestors on January 6th had a point about election rigging, but some were about to walk into a trap laid for them in Washington by the Cult Deep State and its QAnon Psyop. This was the Capitol Hill riot ludicrously dubbed an 'insurrection'.

## **The spider and the fly**

Renegade Minds know there are not two 'sides' in politics, only one side, the Cult, working through all 'sides'. It's a stage show, a puppet show, to direct the perceptions of the population into focusing on diversions like parties and candidates while missing the puppeteers with their hands holding all the strings. The Capitol Hill 'insurrection' brings us back to the Little Big Horn. Having created two distinct opposing groupings – Woke and Pushbackers – the trap was about to be sprung. Pushbackers were to be encircled and isolated by associating them all in the public mind with Trump and then labelling Trump as some sort of Confederate leader. I knew immediately that the Capitol riot was a set-up because of two things. One was how easy the rioters got into the building with virtually no credible resistance and secondly I could see – as with the 'Covid' hoax in the West at the start of 2020 – how the Cult could exploit the situation to move its agenda forward with great speed. My experience of Cult techniques and activities over more than 30 years has showed me that while they do exploit situations they haven't themselves created this never happens with events of fundamental agenda significance. Every time major events giving cultists the excuse to rapidly advance their plan you find they are manipulated into being for the specific reason of providing that excuse – Problem-Reaction-Solution. Only a tiny minority of the huge crowd of Washington protestors sought to gain entry to the Capitol by smashing windows and breaching doors. That didn't matter. The whole crowd and all Pushbackers, even if they did not support Trump, were going to be lumped together as dangerous

insurrectionists and conspiracy theorists. The latter term came into widespread use through a CIA memo in the 1960s aimed at discrediting those questioning the nonsensical official story of the Kennedy assassination and it subsequently became widely employed by the media. It's still being used by inept 'journalists' with no idea of its origin to discredit anyone questioning anything that authority claims to be true. When you are perpetrating a conspiracy you need to discredit the very word itself even though the dictionary definition of conspiracy is merely 'the activity of secretly planning with other people to do something bad or illegal' and 'a general agreement to keep silent about a subject for the purpose of keeping it secret'. On that basis there are conspiracies almost wherever you look. For obvious reasons the Cult and its lapdog media have to claim there are no conspiracies even though the word appears in state laws as with conspiracy to defraud, to murder, and to corrupt public morals.

Agent provocateurs are widely used by the Cult Deep State to manipulate genuine people into acting in ways that suit the desired outcome. By genuine in this case I mean protestors genuinely supporting Trump and claims that the election was stolen. In among them, however, were agents of the state wearing the garb of Trump supporters and QAnon to pump-prime the Capital riot which some genuine Trump supporters naively fell for. I described the situation as 'Come into my parlour said the spider to the fly'. Leaflets appeared through the Woke paramilitary arm Antifa, the anti-fascist fascists, calling on supporters to turn up in Washington looking like Trump supporters even though they hated him. Some of those arrested for breaching the Capitol Building were sourced to Antifa and its stable mate Black Lives Matter. Both organisations are funded by Cult billionaires and corporations. One man charged for the riot was according to his lawyer a former FBI agent who had held top secret security clearance for 40 years. Attorney Thomas Plofchan said of his client, 66-year-old Thomas Edward Caldwell:

He has held a Top Secret Security Clearance since 1979 and has undergone multiple Special Background Investigations in support of his clearances. After retiring from the Navy, he

worked as a section chief for the Federal Bureau of Investigation from 2009-2010 as a GS-12 [mid-level employee].

He also formed and operated a consulting firm performing work, often classified, for U.S government customers including the US. Drug Enforcement Agency, Department of Housing and Urban Development, the US Coast Guard, and the US Army Personnel Command.

A judge later released Caldwell pending trial in the absence of evidence about a conspiracy or that he tried to force his way into the building. *The New York Post* reported a 'law enforcement source' as saying that 'at least two known Antifa members were spotted' on camera among Trump supporters during the riot while one of the rioters arrested was John Earle Sullivan, a seriously extreme Black Lives Matter Trump-hater from Utah who was previously arrested and charged in July, 2020, over a BLM-Antifa riot in which drivers were threatened and one was shot. Sullivan is the founder of Utah-based Insurgence USA which is an affiliate of the Cult-created-and-funded Black Lives Matter movement. Footage appeared and was then deleted by Twitter of Trump supporters calling out Antifa infiltrators and a group was filmed changing into pro-Trump clothing before the riot. Security at the building was *pathetic* – as planned. Colonel Leroy Fletcher Prouty, a man with long experience in covert operations working with the US security apparatus, once described the tell-tale sign to identify who is involved in an assassination. He said:

No one has to direct an assassination – it happens. The active role is played secretly by permitting it to happen. This is the greatest single clue. Who has the power to call off or reduce the usual security precautions?

This principle applies to many other situations and certainly to the Capitol riot of January 6th, 2021.

## **The sting**

With such a big and potentially angry crowd known to be gathering near the Capitol the security apparatus would have had a major police detail to defend the building with National Guard troops on

standby given the strength of feeling among people arriving from all over America encouraged by the QAnon Psyop and statements by Donald Trump. Instead Capitol Police 'security' was flimsy, weak, and easily breached. The same number of officers was deployed as on a regular day and that is a blatant red flag. They were not staffed or equipped for a possible riot that had been an obvious possibility in the circumstances. No protective and effective fencing worth the name was put in place and there were no contingency plans. The whole thing was basically a case of standing aside and waving people in. Once inside police mostly backed off apart from one Capitol police officer who ridiculously shot dead unarmed Air Force veteran protestor Ashli Babbitt without a warning as she climbed through a broken window. The 'investigation' refused to name or charge the officer after what must surely be considered a murder in the circumstances. They just lifted a carpet and swept. The story was endlessly repeated about five people dying in the 'armed insurrection' when there was no report of rioters using weapons. Apart from Babbitt the other four died from a heart attack, strokes and apparently a drug overdose. Capitol police officer Brian Sicknick was reported to have died after being bludgeoned with a fire extinguisher when he was alive after the riot was over and died later of what the Washington Medical Examiner's Office said was a stroke. Sicknick had no external injuries. The lies were delivered like rapid fire. There was a narrative to build with incessant repetition of the lie until the lie became the accepted 'everybody knows that' truth. The 'Big Lie' technique of Nazi Propaganda Minister Joseph Goebbels is constantly used by the Cult which was behind the Nazis and is today behind the 'Covid' and 'climate change' hoaxes. Goebbels said:

If you tell a lie big enough and keep repeating it, people will eventually come to believe it. The lie can be maintained only for such time as the State can shield the people from the political, economic and/or military consequences of the lie. It thus becomes vitally important for the State to use all of its powers to repress dissent, for the truth is the mortal enemy of the lie, and thus by extension, the truth is the greatest enemy of the State.



Most protestors had a free run of the Capitol Building. This allowed pictures to be taken of rioters in iconic parts of the building including the Senate chamber which could be used as propaganda images against all Pushbackers. One Congresswoman described the scene as 'the worst kind of non-security anybody could ever imagine'. Well, the first part was true, but someone obviously did imagine it and made sure it happened. Some photographs most widely circulated featured people wearing QAnon symbols and now the Psyop would be used to dub all QAnon followers with the ubiquitous fit-all label of 'white supremacist' and 'insurrectionists'. When a Muslim extremist called Noah Green drove his car at two police officers at the Capitol Building killing one in April, 2021, there was no such political and media hysteria. They were just disappointed he wasn't white.

## **The witch-hunt**

Government prosecutor Michael Sherwin, an aggressive, dark-eyed, professional Rottweiler led the 'investigation' and to call it over the top would be to understate reality a thousand fold. Hundreds were tracked down and arrested for the crime of having the wrong political views and people were jailed who had done nothing more than walk in the building, committed no violence or damage to property, took a few pictures and left. They were labelled a 'threat to the Republic' while Biden sat in the White House signing executive orders written for him that were dismantling 'the Republic'. Even when judges ruled that a mother and son should not be in jail the government kept them there. Some of those arrested have been badly beaten by prison guards in Washington and lawyers for one man said he suffered a fractured skull and was made blind in one eye. Meanwhile a woman is shot dead for no reason by a Capitol Police officer and we are not allowed to know who he is never mind what has happened to him although that will be *nothing*. The Cult's QAnon/Trump sting to identify and isolate Pushbackers and then target them on the road to crushing and deleting them was a resounding success. You would have thought the Russians had

invaded the building at gunpoint and lined up senators for a firing squad to see the political and media reaction. Congresswoman Alexandria Ocasio-Cortez is a child in a woman's body, a terrible-tvos, me, me, me, Woker narcissist of such proportions that words have no meaning. She said she thought she was going to die when 'insurrectionists' banged on her office door. It turned out she wasn't even in the Capitol Building when the riot was happening and the 'banging' was a Capitol Police officer. She referred to herself as a 'survivor' which is an insult to all those true survivors of violent and sexual abuse while she lives her pampered and privileged life talking drivel for a living. Her Woke colleague and fellow mega-narcissist Rashida Tlaib broke down describing the devastating effect on her, too, of *not being* in the building when the rioters were there. Ocasio-Cortez and Tlaib are members of a fully-Woke group of Congresswomen known as 'The Squad' along with Ilhan Omar and Ayanna Pressley. The Squad from what I can see can be identified by its vehement anti-white racism, anti-white men agenda, and, as always in these cases, the absence of brain cells on active duty.

The usual suspects were on the riot case immediately in the form of Democrat ultra-Zionist senators and operatives Chuck Schumer and Adam Schiff demanding that Trump be impeached for 'his part in the insurrection'. The same pair of prats had led the failed impeachment of Trump over the invented 'Russia collusion' nonsense which claimed Russia had helped Trump win the 2016 election. I didn't realise that Tel Aviv had been relocated just outside Moscow. I must find an up-to-date map. The Russia hoax was a Sabbatian operation to keep Trump occupied and impotent and to stop any rapport with Russia which the Cult wants to retain as a perceptual enemy to be pulled out at will. Puppet Biden began attacking Russia when he came to office as the Cult seeks more upheaval, division and war across the world. A two-year stage show 'Russia collusion inquiry' headed by the not-very-bright former 9/11 FBI chief Robert Mueller, with support from 19 lawyers, 40 FBI agents plus intelligence analysts, forensic accountants and other

staff, devoured tens of millions of dollars and found no evidence of Russia collusion which a ten-year-old could have told them on day one. Now the same moronic Schumer and Schiff wanted a second impeachment of Trump over the Capitol 'insurrection' (riot) which the arrested development of Schumer called another 'Pearl Harbor' while others compared it with 9/11 in which 3,000 died and, in the case of CNN, with the Rwandan genocide in the 1990s in which an estimated 500,000 to 600,000 were murdered, between 250,000 and 500,000 women were raped, and populations of whole towns were hacked to death with machetes. To make those comparisons purely for Cult political reasons is beyond insulting to those that suffered and lost their lives and confirms yet again the callous inhumanity that we are dealing with. Schumer is a monumental idiot and so is Schiff, but they serve the Cult agenda and do whatever they're told so they get looked after. Talking of idiots – another inane man who spanned the Russia and Capitol impeachment attempts was Senator Eric Swalwell who had the nerve to accuse Trump of collusion with the Russians while sleeping with a Chinese spy called Christine Fang or 'Fang Fang' which is straight out of a Bond film no doubt starring Klaus Schwab as the bloke living on a secret island and controlling laser weapons positioned in space and pointing at world capitals. Fang Fang plays the part of Bond's infiltrator girlfriend which I'm sure she would enjoy rather more than sharing a bed with the brainless Swalwell, lying back and thinking of China. The FBI eventually warned Swalwell about Fang Fang which gave her time to escape back to the Chinese dictatorship. How very thoughtful of them. The second Trump impeachment also failed and hardly surprising when an impeachment is supposed to remove a sitting president and by the time it happened Trump was no longer president. These people are running your country America, well, officially anyway. Terrifying isn't it?

### **Outcomes tell the story - always**

The outcome of all this – and it's the *outcome* on which Renegade Minds focus, not the words – was that a vicious, hysterical and

obviously pre-planned assault was launched on Pushbackers to censor, silence and discredit them and even targeted their right to earn a living. They have since been condemned as 'domestic terrorists' that need to be treated like Al-Qaeda and Islamic State. 'Domestic terrorists' is a label the Cult has been trying to make stick since the period of the Oklahoma bombing in 1995 which was blamed on 'far-right domestic terrorists'. If you read *The Trigger* you will see that the bombing was clearly a Problem-Reaction-Solution carried out by the Deep State during a Bill Clinton administration so corrupt that no dictionary definition of the term would even nearly suffice. Nearly 30, 000 troops were deployed from all over America to the empty streets of Washington for Biden's inauguration. Ten thousand of them stayed on with the pretext of protecting the capital from insurrectionists when it was more psychological programming to normalise the use of the military in domestic law enforcement in support of the Cult plan for a police-military state. Biden's fascist administration began a purge of 'wrong-thinkers' in the military which means anyone that is not on board with Woke. The Capitol Building was surrounded by a fence with razor wire and the Land of the Free was further symbolically and literally dismantled. The circle was completed with the installation of Biden and the exploitation of the QAnon Psyop.

America had never been so divided since the civil war of the 19th century, Pushbackers were isolated and dubbed terrorists and now, as was always going to happen, the Cult immediately set about deleting what little was left of freedom and transforming American society through a swish of the hand of the most controlled 'president' in American history leading (officially at least) the most extreme regime since the country was declared an independent state on July 4th, 1776. Biden issued undebated, dictatorial executive orders almost by the hour in his opening days in office across the whole spectrum of the Cult wish-list including diluting controls on the border with Mexico allowing thousands of migrants to illegally enter the United States to transform the demographics of America and import an election-changing number of perceived Democrat

voters. Then there were Biden deportation amnesties for the already illegally resident (estimated to be as high as 20 or even 30 million). A bill before Congress awarded American citizenship to anyone who could prove they had worked in agriculture for just 180 days in the previous two years as 'Big Ag' secured its slave labour long-term. There were the plans to add new states to the union such as Puerto Rico and making Washington DC a state. They are all parts of a plan to ensure that the Cult-owned Woke Democrats would be permanently in power.

### **Border – what border?**

I have exposed in detail in other books how mass immigration into the United States and Europe is the work of Cult networks fuelled by the tens of billions spent to this and other ends by George Soros and his global Open Society (open borders) Foundations. The impact can be seen in America alone where the population has increased by *100 million* in little more than 30 years mostly through immigration. I wrote in *The Answer* that the plan was to have so many people crossing the southern border that the numbers become unstoppable and we are now there under Cult-owned Biden. El Salvador in Central America puts the scale of what is happening into context. A third of the population now lives in the United States, much of it illegally, and many more are on the way. The methodology is to crush Central and South American countries economically and spread violence through machete-wielding psychopathic gangs like MS-13 based in El Salvador and now operating in many American cities. Biden-imposed lax security at the southern border means that it is all but open. He said before his 'election' that he wanted to see a surge towards the border if he became president and that was the green light for people to do just that after election day to create the human disaster that followed for both America and the migrants. When that surge came the imbecilic Alexandria Ocasio-Cortez said it wasn't a 'surge' because they are 'children, not insurgents' and the term 'surge' (used by Biden) was a claim of 'white supremacists'.

This disingenuous lady may one day enter the realm of the most basic intelligence, but it won't be any time soon.

Sabbatians and the Cult are in the process of destroying America by importing violent people and gangs in among the genuine to terrorise American cities and by overwhelming services that cannot cope with the sheer volume of new arrivals. Something similar is happening in Europe as Western society in general is targeted for demographic and cultural transformation and upheaval. The plan demands violence and crime to create an environment of intimidation, fear and division and Soros has been funding the election of district attorneys across America who then stop prosecuting many crimes, reduce sentences for violent crimes and free as many violent criminals as they can. Sabbatians are creating the chaos from which order – their order – can respond in a classic Problem-Reaction-Solution. A Freemasonic motto says 'Ordo Ab Chao' (Order out of Chaos) and this is why the Cult is constantly creating chaos to impose a new 'order'. Here you have the reason the Cult is constantly creating chaos. The 'Covid' hoax can be seen with those entering the United States by plane being forced to take a 'Covid' test while migrants flooding through southern border processing facilities do not. Nothing is put in the way of mass migration and if that means ignoring the government's own 'Covid' rules then so be it. They know it's all bullshit anyway. Any pushback on this is denounced as 'racist' by Wokers and Sabbatian fronts like the ultra-Zionist Anti-Defamation League headed by the appalling Jonathan Greenblatt which at the same time argues that Israel should not give citizenship and voting rights to more Palestinian Arabs or the 'Jewish population' (in truth the Sabbatian network) will lose control of the country.

### **Society-changing numbers**

Biden's masters have declared that countries like El Salvador are so dangerous that their people must be allowed into the United States for humanitarian reasons when there are fewer murders in large parts of many Central American countries than in US cities like

Baltimore. That is not to say Central America cannot be a dangerous place and Cult-controlled American governments have been making it so since way back, along with the dismantling of economies, in a long-term plan to drive people north into the United States. Parts of Central America are very dangerous, but in other areas the story is being greatly exaggerated to justify relaxing immigration criteria. Migrants are being offered free healthcare and education in the United States as another incentive to head for the border and there is no requirement to be financially independent before you can enter to prevent the resources of America being drained. You can't blame migrants for seeking what they believe will be a better life, but they are being played by the Cult for dark and nefarious ends. The numbers since Biden took office are huge. In February, 2021, more than 100,000 people were known to have tried to enter the US illegally through the southern border (it was 34,000 in the same month in 2020) and in March it was 170,000 – a 418 percent increase on March, 2020. These numbers are only known people, not the ones who get in unseen. The true figure for migrants illegally crossing the border in a single month was estimated by one congressman at 250,000 and that number will only rise under Biden's current policy. Gangs of murdering drug-running thugs that control the Mexican side of the border demand money – thousands of dollars – to let migrants cross the Rio Grande into America. At the same time gun battles are breaking out on the border several times a week between rival Mexican drug gangs (which now operate globally) who are equipped with sophisticated military-grade weapons, grenades and armoured vehicles. While the Capitol Building was being 'protected' from a non-existent 'threat' by thousands of troops, and others were still deployed at the time in the Cult Neocon war in Afghanistan, the southern border of America was left to its fate. This is not incompetence, it is cold calculation.

By March, 2021, there were 17,000 unaccompanied children held at border facilities and many of them are ensnared by people traffickers for paedophile rings and raped on their journey north to America. This is not conjecture – this is fact. Many of those designated

children are in reality teenage boys or older. Meanwhile Wokers posture their self-purity for encouraging poor and tragic people to come to America and face this nightmare both on the journey and at the border with the disgusting figure of House Speaker Nancy Pelosi giving disingenuous speeches about caring for migrants. The woman's evil. Wokers condemned Trump for having children in cages at the border (so did Obama, *Shhhh*), but now they are sleeping on the floor without access to a shower with one border facility 729 percent over capacity. The Biden insanity even proposed flying migrants from the southern border to the northern border with Canada for 'processing'. The whole shambles is being overseen by ultra-Zionist Secretary of Homeland Security, the moronic liar Alejandro Mayorkas, who banned news cameras at border facilities to stop Americans seeing what was happening. Mayorkas said there was not a ban on news crews; it was just that they were not allowed to film. Alongside him at Homeland Security is another ultra-Zionist Cass Sunstein appointed by Biden to oversee new immigration laws. Sunstein despises conspiracy researchers to the point where he suggests they should be banned or *taxed* for having such views. The man is not bonkers or anything. He's perfectly well-adjusted, but adjusted to what is the question. Criticise what is happening and you are a 'white supremacist' when earlier non-white immigrants also oppose the numbers which effect their lives and opportunities. Black people in poor areas are particularly damaged by uncontrolled immigration and the increased competition for work opportunities with those who will work for less. They are also losing voting power as Hispanics become more dominant in former black areas. It's a downward spiral for them while the billionaires behind the policy drone on about how much they care about black people and 'racism'. None of this is about compassion for migrants or black people – that's just wind and air. Migrants are instead being mercilessly exploited to transform America while the countries they leave are losing their future and the same is true in Europe. Mass immigration may now be the work of Woke Democrats, but it can be traced back to the 1986 Immigration Reform and Control Act (it



wasn't) signed into law by Republican hero President Ronald Reagan which gave amnesty to millions living in the United States illegally and other incentives for people to head for the southern border. Here we have the one-party state at work again.

## **Save me syndrome**

Almost every aspect of what I have been exposing as the Cult agenda was on display in even the first days of 'Biden' with silencing of Pushbackers at the forefront of everything. A Renegade Mind will view the Trump years and QAnon in a very different light to their supporters and advocates as the dots are connected. The QAnon/Trump Psyop has given the Cult all it was looking for. We may not know how much, or little, that Trump realised he was being used, but that's a side issue. This pincer movement produced the desired outcome of dividing America and having Pushbackers isolated. To turn this around we have to look at new routes to empowerment which do not include handing our power to other people and groups through what I will call the 'Save Me Syndrome' – 'I want someone else to do it so that I don't have to'. We have seen this at work throughout human history and the QAnon/Trump Psyop is only the latest incarnation alongside all the others. Religion is an obvious expression of this when people look to a 'god' or priest to save them or tell them how to be saved and then there are 'save me' politicians like Trump. Politics is a diversion and not a 'saviour'. It is a means to block positive change, not make it possible.

Save Me Syndrome always comes with the same repeating theme of handing your power to whom or what you believe will save you while your real 'saviour' stares back from the mirror every morning. Renegade Minds are constantly vigilant in this regard and always asking the question 'What can I do?' rather than 'What can someone else do for me?' Gandhi was right when he said: 'You must be the change you want to see in the world.' We are indeed the people we have been waiting for. We are presented with a constant raft of reasons to concede that power to others and forget where the real power is. Humanity has the numbers and the Cult does not. It has to

use diversion and division to target the unstoppable power that comes from unity. Religions, governments, politicians, corporations, media, QAnon, are all different manifestations of this power-diversion and dilution. Refusing to give your power to governments and instead handing it to Trump and QAnon is not to take a new direction, but merely to recycle the old one with new names on the posters. I will explore this phenomenon as we proceed and how to break the cycles and recycles that got us here through the mists of repeating perception and so repeating history.

For now we shall turn to the most potent example in the entire human story of the consequences that follow when you give your power away. I am talking, of course, of the 'Covid' hoax.

## CHAPTER FOUR

### **'Covid': Calculated catastrophe**

*Facts are threatening to those invested in fraud*  
DaShanne Stokes

**W**e can easily unravel the real reason for the 'Covid pandemic' hoax by employing the Renegade Mind methodology that I have outlined this far. We'll start by comparing the long-planned Cult outcome with the 'Covid pandemic' outcome. Know the outcome and you'll see the journey.

I have highlighted the plan for the Hunger Games Society which has been in my books for so many years with the very few controlling the very many through ongoing dependency. To create this dependency it is essential to destroy independent livelihoods, businesses and employment to make the population reliant on the state (the Cult) for even the basics of life through a guaranteed pittance income. While independence of income remained these Cult ambitions would be thwarted. With this knowledge it was easy to see where the 'pandemic' hoax was going once talk of 'lockdowns' began and the closing of all but perceived 'essential' businesses to 'save' us from an alleged 'deadly virus'. Cult corporations like Amazon and Walmart were naturally considered 'essential' while mom and pop shops and stores had their doors closed by fascist decree. As a result with every new lockdown and new regulation more small and medium, even large businesses not owned by the Cult, went to the wall while Cult giants and their frontmen and women grew financially fatter by the second. Mom and pop were

denied an income and the right to earn a living and the wealth of people like Jeff Bezos (Amazon), Mark Zuckerberg (Facebook) and Sergei Brin and Larry Page (Google/Alphabet) have reached record levels. The Cult was increasing its own power through further dramatic concentrations of wealth while the competition was being destroyed and brought into a state of dependency. Lockdowns have been instigated to secure that very end and were never anything to do with health. My brother Paul spent 45 years building up a bus repair business, but lockdowns meant buses were running at a fraction of normal levels for months on end. Similar stories can be told in their hundreds of millions worldwide. Efforts of a lifetime coldly destroyed by Cult multi-billionaires and their lackeys in government and law enforcement who continued to earn their living from the taxation of the people while denying the right of the same people to earn theirs. How different it would have been if those making and enforcing these decisions had to face the same financial hardships of those they affected, but they never do.

## **Gates of Hell**

Behind it all in the full knowledge of what he is doing and why is the psychopathic figure of Cult operative Bill Gates. His puppet Tedros at the World Health Organization declared 'Covid' a pandemic in March, 2020. The WHO had changed the definition of a 'pandemic' in 2009 just a month before declaring the 'swine flu pandemic' which would not have been so under the previous definition. The same applies to 'Covid'. The definition had included... 'an infection by an infectious agent, occurring simultaneously in different countries, with a significant mortality rate relative to the proportion of the population infected'. The new definition removed the need for 'significant mortality'. The 'pandemic' has been fraudulent even down to the definition, but Gates demanded economy-destroying lockdowns, school closures, social distancing, mandatory masks, a 'vaccination' for every man, woman and child on the planet and severe consequences and restrictions for those that refused. Who gave him this power? The

Cult did which he serves like a little boy in short trousers doing what his daddy tells him. He and his psychopathic missus even smiled when they said that much worse was to come (what they knew was planned to come). Gates responded in the matter-of-fact way of all psychopaths to a question about the effect on the world economy of what he was doing:

Well, it won't go to zero but it will shrink. Global GDP is probably going to take the biggest hit ever [Gates was smiling as he said this] ... in my lifetime this will be the greatest economic hit. But you don't have a choice. People act as if you have a choice. People don't feel like going to the stadium when they might get infected ... People are deeply affected by seeing these stats, by knowing they could be part of the transmission chain, old people, their parents and grandparents, could be affected by this, and so you don't get to say ignore what is going on here.

There will be the ability to open up, particularly in rich countries, if things are done well over the next few months, but for the world at large normalcy only returns when we have largely vaccinated the entire population.

The man has no compassion or empathy. How could he when he's a psychopath like all Cult players? My own view is that even beyond that he is very seriously mentally ill. Look in his eyes and you can see this along with his crazy flailing arms. You don't do what he has done to the world population since the start of 2020 unless you are mentally ill and at the most extreme end of psychopathic. You especially don't do it when to you know, as we shall see, that cases and deaths from 'Covid' are fakery and a product of monumental figure massaging. 'These stats' that Gates referred to are based on a 'test' that's not testing for the 'virus' as he has known all along. He made his fortune with big Cult support as an infamously ruthless software salesman and now buys global control of 'health' (death) policy without the population he affects having any say. It's a breathtaking outrage. Gates talked about people being deeply affected by fear of 'Covid' when that was because of *him* and his global network lying to them minute-by-minute supported by a lying media that he seriously influences and funds to the tune of hundreds of millions. He's handed big sums to media operations including the BBC, NBC, Al Jazeera, Univision, *PBS NewsHour*,

*ProPublica, National Journal, The Guardian, The Financial Times, The Atlantic, Texas Tribune, USA Today publisher Gannett, Washington Monthly, Le Monde, Center for Investigative Reporting, Pulitzer Center on Crisis Reporting, National Press Foundation, International Center for Journalists, Solutions Journalism Network, the Poynter Institute for Media Studies, and many more. Gates is everywhere in the 'Covid' hoax and the man must go to prison – or a mental facility – for the rest of his life and his money distributed to those he has taken such enormous psychopathic pleasure in crushing.*

## **The Muscle**

The Hunger Games global structure demands a police-military state – a fusion of the two into one force – which viciously imposes the will of the Cult on the population and protects the Cult from public rebellion. In that regard, too, the 'Covid' hoax just keeps on giving. Often unlawful, ridiculous and contradictory 'Covid' rules and regulations have been policed across the world by moronic automatons and psychopaths made faceless by face-nappy masks and acting like the Nazi SS and fascist blackshirts and brownshirts of Hitler and Mussolini. The smallest departure from the rules decreed by the psychos in government and their clueless gofers were jumped upon by the face-nappy fascists. Brutality against public protestors soon became commonplace even on girls, women and old people as the brave men with the batons – the Face-Nappies as I call them – broke up peaceful protests and handed out fines like confetti to people who couldn't earn a living let alone pay hundreds of pounds for what was once an accepted human right. Robot Face-Nappies of Nottingham police in the English East Midlands fined one group £11,000 for attending a child's birthday party. For decades I charted the transformation of law enforcement as genuine, decent officers were replaced with psychopaths and the brain dead who would happily and brutally do whatever their masters told them. Now they were let loose on the public and I would emphasise the point that none of this just happened. The step-by-step change in the dynamic between police and public was orchestrated from the shadows by

those who knew where this was all going and the same with the perceptual reframing of those in all levels of authority and official administration through 'training courses' by organisations such as Common Purpose which was created in the late 1980s and given a massive boost in Blair era Britain until it became a global phenomenon. Supposed public 'servants' began to view the population as the enemy and the same was true of the police. This was the start of the explosion of behaviour manipulation organisations and networks preparing for the all-war on the human psyche unleashed with the dawn of 2020. I will go into more detail about this later in the book because it is a core part of what is happening.

Police desecrated beauty spots to deter people gathering and arrested women for walking in the countryside alone 'too far' from their homes. We had arrogant, clueless sergeants in the Isle of Wight police where I live posting on Facebook what they insisted the population must do or else. A schoolmaster sergeant called Radford looked young enough for me to ask if his mother knew he was out, but he was posting what he *expected* people to do while a Sergeant Wilkinson boasted about fining lads for meeting in a McDonald's car park where they went to get a lockdown takeaway. Wilkinson added that he had even cancelled their order. What a pair of prats these people are and yet they have increasingly become the norm among Jackboot Johnson's Yellowshirts once known as the British police. This was the theme all over the world with police savagery common during lockdown protests in the United States, the Netherlands, and the fascist state of Victoria in Australia under its tyrannical and again moronic premier Daniel Andrews. Amazing how tyrannical and moronic tend to work as a team and the same combination could be seen across America as arrogant, narcissistic Woke governors and mayors such as Gavin Newsom (California), Andrew Cuomo (New York), Gretchen Whitmer (Michigan), Lori Lightfoot (Chicago) and Eric Garcetti (Los Angeles) did their Nazi and Stalin impressions with the full support of the compliant brutality of their enforcers in uniform as they arrested small business owners defying

fascist shutdown orders and took them to jail in ankle shackles and handcuffs. This happened to bistro owner Marlena Pavlos-Hackney in Gretchen Whitmer's fascist state of Michigan when police arrived to enforce an order by a state-owned judge for 'putting the community at risk' at a time when other states like Texas were dropping restrictions and migrants were pouring across the southern border without any 'Covid' questions at all. I'm sure there are many officers appalled by what they are ordered to do, but not nearly enough of them. If they were truly appalled they would not do it. As the months passed every opportunity was taken to have the military involved to make their presence on the streets ever more familiar and 'normal' for the longer-term goal of police-military fusion.

Another crucial element to the Hunger Games enforcement network has been encouraging the public to report neighbours and others for 'breaking the lockdown rules'. The group faced with £11,000 in fines at the child's birthday party would have been dobbed-in by a neighbour with a brain the size of a pea. The technique was most famously employed by the Stasi secret police in communist East Germany who had public informants placed throughout the population. A police chief in the UK says his force doesn't need to carry out 'Covid' patrols when they are flooded with so many calls from the public reporting other people for visiting the beach. Dorset police chief James Vaughan said people were so enthusiastic about snitching on their fellow humans they were now operating as an auxiliary arm of the police: 'We are still getting around 400 reports a week from the public, so we will respond to reports ... We won't need to be doing hotspot patrols because people are very quick to pick the phone up and tell us.' Vaughan didn't say that this is a pillar of all tyrannies of whatever complexion and the means to hugely extend the reach of enforcement while spreading distrust among the people and making them wary of doing anything that might get them reported. Those narcissistic Isle of Wight sergeants Radford and Wilkinson never fail to add a link to their Facebook posts where the public can inform on their fellow slaves.



Neither would be self-aware enough to realise they were imitating the Stasi which they might well never have heard of. Government psychologists that I will expose later laid out a policy to turn communities against each other in the same way.

### **A coincidence? Yep, and I can knit fog**

I knew from the start of the alleged pandemic that this was a Cult operation. It presented limitless potential to rapidly advance the Cult agenda and exploit manipulated fear to demand that every man, woman and child on the planet was 'vaccinated' in a process never used on humans before which infuses self-replicating *synthetic* material into human cells. Remember the plan to transform the human body from a biological to a synthetic biological state. I'll deal with the 'vaccine' (that's not actually a vaccine) when I focus on the genetic agenda. Enough to say here that mass global 'vaccination' justified by this 'new virus' set alarms ringing after 30 years of tracking these people and their methods. The 'Covid' hoax officially beginning in China was also a big red flag for reasons I will be explaining. The agenda potential was so enormous that I could dismiss any idea that the 'virus' appeared naturally. Major happenings with major agenda implications never occur without Cult involvement in making them happen. My questions were twofold in early 2020 as the media began its campaign to induce global fear and hysteria: Was this alleged infectious agent released on purpose by the Cult or did it even exist at all? I then did what I always do in these situations. I sat, observed and waited to see where the evidence and information would take me. By March and early April synchronicity was strongly – and ever more so since then – pointing me in the direction of *there is no 'virus'*. I went public on that with derision even from swathes of the alternative media that voiced a scenario that the Chinese government released the 'virus' in league with Deep State elements in the United States from a top-level bio-lab in Wuhan where the 'virus' is said to have first appeared. I looked at that possibility, but I didn't buy it for several reasons. Deaths from the 'virus' did not in any way match what they

would have been with a 'deadly bioweapon' and it is much more effective if you sell the *illusion* of an infectious agent rather than having a real one unless you can control through injection who has it and who doesn't. Otherwise you lose control of events. A made-up 'virus' gives you a blank sheet of paper on which you can make it do whatever you like and have any symptoms or mutant 'variants' you choose to add while a real infectious agent would limit you to what it actually does. A phantom disease allows you to have endless ludicrous 'studies' on the 'Covid' dollar to widen the perceived impact by inventing ever more 'at risk' groups including one study which said those who walk slowly may be almost four times more likely to die from the 'virus'. People are in psychiatric wards for less.

A real 'deadly bioweapon' can take out people in the hierarchy that are not part of the Cult, but essential to its operation. Obviously they don't want that. Releasing a real disease means you immediately lose control of it. Releasing an illusory one means you don't. Again it's vital that people are extra careful when dealing with what they want to hear. A bioweapon unleashed from a Chinese laboratory in collusion with the American Deep State may fit a conspiracy narrative, but is it true? Would it not be far more effective to use the excuse of a 'virus' to justify the real bioweapon – the 'vaccine'? That way your disease agent does not have to be transmitted and arrives directly through a syringe. I saw a French virologist Luc Montagnier quoted in the alternative media as saying he had discovered that the alleged 'new' severe acute respiratory syndrome coronavirus, or SARS-CoV-2, was made artificially and included elements of the human immunodeficiency 'virus' (HIV) and a parasite that causes malaria. SARS-CoV-2 is alleged to trigger an alleged illness called Covid-19. I remembered Montagnier's name from my research years before into claims that an HIV 'retrovirus' causes AIDs – claims that were demolished by Berkeley virologist Peter Duesberg who showed that no one had ever proved that HIV causes acquired immunodeficiency syndrome or AIDS. Claims that become accepted as fact, publicly and medically, with no proof whatsoever are an ever-recurring story that profoundly applies to

'Covid'. Nevertheless, despite the lack of proof, Montagnier's team at the Pasteur Institute in Paris had a long dispute with American researcher Robert Gallo over which of them discovered and isolated the HIV 'virus' and with *no evidence* found it to cause AIDS. You will see later that there is also no evidence that any 'virus' causes any disease or that there is even such a thing as a 'virus' in the way it is said to exist. The claim to have 'isolated' the HIV 'virus' will be presented in its real context as we come to the shocking story – and it is a story – of SARS-CoV-2 and so will Montagnier's assertion that he identified the full SARS-CoV-2 genome.

### **Hoax in the making**

We can pick up the 'Covid' story in 2010 and the publication by the Rockefeller Foundation of a document called 'Scenarios for the Future of Technology and International Development'. The inner circle of the Rockefeller family has been serving the Cult since John D. Rockefeller (1839-1937) made his fortune with Standard Oil. It is less well known that the same Rockefeller – the Bill Gates of his day – was responsible for establishing what is now referred to as 'Big Pharma', the global network of pharmaceutical companies that make outrageous profits dispensing scalpel and drug 'medicine' and are obsessed with pumping vaccines in ever-increasing number into as many human arms and backsides as possible. John D. Rockefeller was the driving force behind the creation of the 'education' system in the United States and elsewhere specifically designed to program the perceptions of generations thereafter. The Rockefeller family donated exceptionally valuable land in New York for the United Nations building and were central in establishing the World Health Organization in 1948 as an agency of the UN which was created from the start as a Trojan horse and stalking horse for world government. Now enter Bill Gates. His family and the Rockefellers have long been extremely close and I have seen genealogy which claims that if you go back far enough the two families fuse into the same bloodline. Gates has said that the Bill and Melinda Gates Foundation was inspired by the Rockefeller Foundation and why not

when both are serving the same Cult? Major tax-exempt foundations are overwhelmingly criminal enterprises in which Cult assets fund the Cult agenda in the guise of 'philanthropy' while avoiding tax in the process. Cult operatives can become mega-rich in their role of front men and women for the psychopaths at the inner core and they, too, have to be psychopaths to knowingly serve such evil. Part of the deal is that a big percentage of the wealth gleaned from representing the Cult has to be spent advancing the ambitions of the Cult and hence you have the Rockefeller Foundation, Bill and Melinda Gates Foundation (and *so* many more) and people like George Soros with his global Open Society Foundations spending their billions in pursuit of global Cult control. Gates is a global public face of the Cult with his interventions in world affairs including Big Tech influence; a central role in the 'Covid' and 'vaccine' scam; promotion of the climate change shakedown; manipulation of education; geoengineering of the skies; and his food-control agenda as the biggest owner of farmland in America, his GMO promotion and through other means. As one writer said: 'Gates monopolizes or wields disproportionate influence over the tech industry, global health and vaccines, agriculture and food policy (including biopiracy and fake food), weather modification and other climate technologies, surveillance, education and media.' The almost limitless wealth secured through Microsoft and other not-allowed-to-fail ventures (including vaccines) has been ploughed into a long, long list of Cult projects designed to enslave the entire human race. Gates and the Rockefellers have been working as one unit with the Rockefeller-established World Health Organization leading global 'Covid' policy controlled by Gates through his mouth-piece Tedros. Gates became the WHO's biggest funder when Trump announced that the American government would cease its donations, but Biden immediately said he would restore the money when he took office in January, 2021. The Gates Foundation (the Cult) owns through limitless funding the world health system and the major players across the globe in the 'Covid' hoax.

Okay, with that background we return to that Rockefeller Foundation document of 2010 headed 'Scenarios for the Future of Technology and International Development' and its 'imaginary' epidemic of a virulent and deadly influenza strain which infected 20 percent of the global population and killed eight million in seven months. The Rockefeller scenario was that the epidemic destroyed economies, closed shops, offices and other businesses and led to governments imposing fierce rules and restrictions that included mandatory wearing of face masks and body-temperature checks to enter communal spaces like railway stations and supermarkets. The document predicted that even after the height of the Rockefeller-envisaged epidemic the authoritarian rule would continue to deal with further pandemics, transnational terrorism, environmental crises and rising poverty. Now you may think that the Rockefellers are our modern-day seers or alternatively, and rather more likely, that they well knew what was planned a few years further on. Fascism had to be imposed, you see, to 'protect citizens from risk and exposure'. The Rockefeller scenario document said:

During the pandemic, national leaders around the world flexed their authority and imposed airtight rules and restrictions, from the mandatory wearing of face masks to body-temperature checks at the entries to communal spaces like train stations and supermarkets. Even after the pandemic faded, this more authoritarian control and oversight of citizens and their activities stuck and even intensified. In order to protect themselves from the spread of increasingly global problems – from pandemics and transnational terrorism to environmental crises and rising poverty – leaders around the world took a firmer grip on power.

At first, the notion of a more controlled world gained wide acceptance and approval. Citizens willingly gave up some of their sovereignty – and their privacy – to more paternalistic states in exchange for greater safety and stability. Citizens were more tolerant, and even eager, for top-down direction and oversight, and national leaders had more latitude to impose order in the ways they saw fit.

In developed countries, this heightened oversight took many forms: biometric IDs for all citizens, for example, and tighter regulation of key industries whose stability was deemed vital to national interests. In many developed countries, enforced cooperation with a suite of new regulations and agreements slowly but steadily restored both order and, importantly, economic growth.

There we have the prophetic Rockefellers in 2010 and three years later came their paper for the Global Health Summit in Beijing, China, when government representatives, the private sector, international organisations and groups met to discuss the next 100 years of 'global health'. The Rockefeller Foundation-funded paper was called 'Dreaming the Future of Health for the Next 100 Years and more prophecy ensued as it described a dystopian future: 'The abundance of data, digitally tracking and linking people may mean the 'death of privacy' and may replace physical interaction with transient, virtual connection, generating isolation and raising questions of how values are shaped in virtual networks.' Next in the 'Covid' hoax preparation sequence came a 'table top' simulation in 2018 for another 'imaginary' pandemic of a disease called Clade X which was said to kill 900 million people. The exercise was organised by the Gates-funded Johns Hopkins University's Center for Health Security in the United States and this is the very same university that has been compiling the disgustingly and systematically erroneous global figures for 'Covid' cases and deaths. Similar Johns Hopkins health crisis scenarios have included the Dark Winter exercise in 2001 and Atlantic Storm in 2005.

## **Nostradamus 201**

For sheer predictive genius look no further prophecy-watchers than the Bill Gates-funded Event 201 held only six weeks before the 'coronavirus pandemic' is supposed to have broken out in China and Event 201 was based on a scenario of a global 'coronavirus pandemic'. Melinda Gates, the great man's missus, told the BBC that he had 'prepared for years' for a coronavirus pandemic which told us what we already knew. Nostradamugates had predicted in a TED talk in 2015 that a pandemic was coming that would kill a lot of people and demolish the world economy. My god, the man is a machine – possibly even literally. Now here he was only weeks before the real thing funding just such a simulated scenario and involving his friends and associates at Johns Hopkins, the World Economic Forum Cult-front of Klaus Schwab, the United Nations,

Johnson & Johnson, major banks, and officials from China and the Centers for Disease Control in the United States. What synchronicity – Johns Hopkins would go on to compile the fraudulent ‘Covid’ figures, the World Economic Forum and Schwab would push the ‘Great Reset’ in response to ‘Covid’, the Centers for Disease Control would be at the forefront of ‘Covid’ policy in the United States, Johnson & Johnson would produce a ‘Covid vaccine’, and everything would officially start just weeks later in China. Spooky, eh? They were even accurate in creating a simulation of a ‘virus’ pandemic because the ‘real thing’ would also be a simulation. Event 201 was not an exercise preparing for something that might happen; it was a rehearsal for what those in control knew was *going* to happen and very shortly. Hours of this simulation were posted on the Internet and the various themes and responses mirrored what would soon be imposed to transform human society. News stories were inserted and what they said would be commonplace a few weeks later with still more prophecy perfection. Much discussion focused on the need to deal with misinformation and the ‘anti-vax movement’ which is exactly what happened when the ‘virus’ arrived – was said to have arrived – in the West.

Cult-owned social media banned criticism and exposure of the official ‘virus’ narrative and when I said there *was* no ‘virus’ in early April, 2020, I was banned by one platform after another including YouTube, Facebook and later Twitter. The mainstream broadcast media in Britain was in effect banned from interviewing me by the Tony-Blair-created government broadcasting censor Ofcom headed by career government bureaucrat Melanie Dawes who was appointed just as the ‘virus’ hoax was about to play out in January, 2020. At the same time the Ickonic media platform was using Vimeo, another ultra-Zionist-owned operation, while our own player was being created and they deleted in an instant hundreds of videos, documentaries, series and shows to confirm their unbelievable vindictiveness. We had copies, of course, and they had to be restored one by one when our player was ready. These people have no class. Sabbatian Facebook promised free advertisements for the Gates-

controlled World Health Organization narrative while deleting ‘false claims and conspiracy theories’ to stop ‘misinformation’ about the alleged coronavirus. All these responses could be seen just a short while earlier in the scenarios of Event 201. Extreme censorship was absolutely crucial for the Cult because the official story was so ridiculous and unsupportable by the evidence that it could never survive open debate and the free-flow of information and opinion. If you can’t win a debate then don’t have one is the Cult’s approach throughout history. Facebook’s little boy front man – front boy – Mark Zuckerberg equated ‘credible and accurate information’ with official sources and exposing their lies with ‘misinformation’.

### **Silencing those that can see**

The censorship dynamic of Event 201 is now the norm with an army of narrative-supporting ‘fact-checker’ organisations whose entire reason for being is to tell the public that official narratives are true and those exposing them are lying. One of the most appalling of these ‘fact-checkers’ is called NewsGuard founded by ultra-Zionist Americans Gordon Crovitz and Steven Brill. Crovitz is a former publisher of *The Wall Street Journal*, former Executive Vice President of Dow Jones, a member of the Council on Foreign Relations (CFR), and on the board of the American Association of Rhodes Scholars. The CFR and Rhodes Scholarships, named after Rothschild agent Cecil Rhodes who plundered the gold and diamonds of South Africa for his masters and the Cult, have featured widely in my books. NewsGuard don’t seem to like me for some reason – I really can’t think why – and they have done all they can to have me censored and discredited which is, to quote an old British politician, like being savaged by a dead sheep. They are, however, like all in the censorship network, very well connected and funded by organisations themselves funded by, or connected to, Bill Gates. As you would expect with anything associated with Gates NewsGuard has an offshoot called HealthGuard which ‘fights online health care hoaxes’. How very kind. Somehow the NewsGuard European Managing Director Anna-Sophie Harling, a remarkably young-



looking woman with no broadcasting experience and little hands-on work in journalism, has somehow secured a position on the 'Content Board' of UK government broadcast censor Ofcom. An executive of an organisation seeking to discredit dissidents of the official narratives is making decisions for the government broadcast 'regulator' about content?? Another appalling 'fact-checker' is Full Fact funded by George Soros and global censors Google and Facebook.

It's amazing how many activists in the 'fact-checking', 'anti-hate', arena turn up in government-related positions – people like UK Labour Party activist Imran Ahmed who heads the Center for Countering Digital Hate founded by people like Morgan McSweeney, now chief of staff to the Labour Party's hapless and useless 'leader' Keir Starmer. Digital Hate – which is what it really is – uses the American spelling of Center to betray its connection to a transatlantic network of similar organisations which in 2020 shapeshifted from attacking people for 'hate' to attacking them for questioning the 'Covid' hoax and the dangers of the 'Covid vaccine'. It's just a coincidence, you understand. This is one of Imran Ahmed's hysterical statements: 'I would go beyond calling anti-vaxxers conspiracy theorists to say they are an extremist group that pose a national security risk.' No one could ever accuse this prat of understatement and he's including in that those parents who are now against vaccines after their children were damaged for life or killed by them. He's such a nice man. Ahmed does the rounds of the Woke media getting soft-ball questions from spineless 'journalists' who never ask what right he has to campaign to destroy the freedom of speech of others while he demands it for himself. There also seems to be an overrepresentation in Ofcom of people connected to the narrative-worshipping BBC. This incredible global network of narrative-support was super-vital when the 'Covid' hoax was played in the light of the mega-whopper lies that have to be defended from the spotlight cast by the most basic intelligence.

## **Setting the scene**

The Cult plays the long game and proceeds step-by-step ensuring that everything is in place before major cards are played and they don't come any bigger than the 'Covid' hoax. The psychopaths can't handle events where the outcome isn't certain and as little as possible – preferably nothing – is left to chance. Politicians, government and medical officials who would follow direction were brought to illusory power in advance by the Cult web whether on the national stage or others like state governors and mayors of America. For decades the dynamic between officialdom, law enforcement and the public was changed from one of service to one of control and dictatorship. Behaviour manipulation networks established within government were waiting to impose the coming 'Covid' rules and regulations specifically designed to subdue and rewire the psyche of the people in the guise of protecting health. These included in the UK the Behavioural Insights Team part-owned by the British government Cabinet Office; the Scientific Pandemic Insights Group on Behaviours (SPI-B); and a whole web of intelligence and military groups seeking to direct the conversation on social media and control the narrative. Among them are the cyberwarfare (on the people) 77th Brigade of the British military which is also coordinated through the Cabinet Office as civilian and military leadership continues to combine in what they call the Fusion Doctrine. The 77th Brigade is a British equivalent of the infamous Israeli (Sabbatian) military cyberwarfare and Internet manipulation operation Unit 8200 which I expose at length in *The Trigger*. Also carefully in place were the medical and science advisers to government – many on the payroll past or present of Bill Gates – and a whole alternative structure of unelected government stood by to take control when elected parliaments were effectively closed down once the 'Covid' card was slammed on the table. The structure I have described here and so much more was installed in every major country through the Cult networks. The top-down control hierarchy looks like this: The Cult – Cult-owned Gates – the World Health Organization and Tedros – Gates-funded or controlled chief medical officers and science 'advisers' (dictators) in each country –

political 'leaders' – law enforcement – The People. Through this simple global communication and enforcement structure the policy of the Cult could be imposed on virtually the entire human population so long as they acquiesced to the fascism. With everything in place it was time for the button to be pressed in late 2019/early 2020.

These were the prime goals the Cult had to secure for its will to prevail:

1) Locking down economies, closing all but designated 'essential' businesses (Cult-owned corporations were 'essential'), and putting the population under house arrest was an imperative to destroy independent income and employment and ensure dependency on the Cult-controlled state in the Hunger Games Society. Lockdowns had to be established as the global blueprint from the start to respond to the 'virus' and followed by pretty much the entire world.

2) The global population had to be terrified into believing in a deadly 'virus' that didn't actually exist so they would unquestioningly obey authority in the belief that authority must know how best to protect them and their families. Software salesman Gates would suddenly morph into the world's health expert and be promoted as such by the Cult-owned media.

3) A method of testing that wasn't testing for the 'virus', but was only claimed to be, had to be in place to provide the illusion of 'cases' and subsequent 'deaths' that had a very different cause to the 'Covid-19' that would be scribbled on the death certificate.

4) Because there was no 'virus' and the great majority testing positive with a test not testing for the 'virus' would have no symptoms of anything the lie had to be sold that people without symptoms (without the 'virus') could still pass it on to others. This was crucial to justify for the first time quarantining – house arresting – healthy people. Without this the economy-destroying lockdown of *everybody* could not have been credibly sold.

5) The 'saviour' had to be seen as a vaccine which beyond evil drug companies were working like angels of mercy to develop as quickly as possible, with all corners cut, to save the day. The public must absolutely not know that the 'vaccine' had nothing to do with a 'virus' or that the contents were ready and waiting with a very different motive long before the 'Covid' card was even lifted from the pack.

I said in March, 2020, that the 'vaccine' would have been created way ahead of the 'Covid' hoax which justified its use and the following December an article in the New York *Intelligencer* magazine said the Moderna 'vaccine' had been 'designed' by

January, 2020. This was 'before China had even acknowledged that the disease could be transmitted from human to human, more than a week before the first confirmed coronavirus case in the United States'. The article said that by the time the first American death was announced a month later 'the vaccine had already been manufactured and shipped to the National Institutes of Health for the beginning of its Phase I clinical trial'. The 'vaccine' was actually 'designed' long before that although even with this timescale you would expect the article to ask how on earth it could have been done that quickly. Instead it asked why the 'vaccine' had not been rolled out then and not months later. Journalism in the mainstream is truly dead. I am going to detail in the next chapter why the 'virus' has never existed and how a hoax on that scale was possible, but first the foundation on which the Big Lie of 'Covid' was built.

### **The test that doesn't test**

Fraudulent 'testing' is the bottom line of the whole 'Covid' hoax and was the means by which a 'virus' that did not exist *appeared* to exist. They could only achieve this magic trick by using a test not testing for the 'virus'. To use a test that *was* testing for the 'virus' would mean that every test would come back negative given there was no 'virus'. They chose to exploit something called the RT-PCR test invented by American biochemist Kary Mullis in the 1980s who said publicly that his PCR test ... *cannot detect infectious disease*. Yes, the 'test' used worldwide to detect infectious 'Covid' to produce all the illusory 'cases' and 'deaths' compiled by Johns Hopkins and others *cannot detect infectious disease*. This fact came from the mouth of the man who invented PCR and was awarded the Nobel Prize in Chemistry in 1993 for doing so. Sadly, and incredibly conveniently for the Cult, Mullis died in August, 2019, at the age of 74 just before his test would be fraudulently used to unleash fascism on the world. He was said to have died from pneumonia which was an irony in itself. A few months later he would have had 'Covid-19' on his death certificate. I say the timing of his death was convenient because had he lived Mullis, a brilliant, honest and decent man, would have been

vociferously speaking out against the use of his test to detect 'Covid' when it was never designed, or able, to do that. I know that to be true given that Mullis made the same point when his test was used to 'detect' – not detect – HIV. He had been seriously critical of the Gallo/Montagnier claim to have isolated the HIV 'virus' and shown it to cause AIDS for which Mullis said there was no evidence. AIDS is actually not a disease but a series of diseases from which people die all the time. When they die from those *same diseases* after a positive 'test' for HIV then AIDS goes on their death certificate. I think I've heard that before somewhere. Countries instigated a policy with 'Covid' that anyone who tested positive with a test not testing for the 'virus' and died of any other cause within 28 days and even longer 'Covid-19' had to go on the death certificate. Cases have come from the test that can't test for infectious disease and the deaths are those who have died of *anything* after testing positive with a test not testing for the 'virus'. I'll have much more later about the death certificate scandal.

Mullis was deeply dismissive of the now US 'Covid' star Anthony Fauci who he said was a liar who didn't know anything about anything – 'and I would say that to his face – nothing.' He said of Fauci: 'The man thinks he can take a blood sample, put it in an electron microscope and if it's got a virus in there you'll know it – he doesn't understand electron microscopy and he doesn't understand medicine and shouldn't be in a position like he's in.' That position, terrifyingly, has made him the decider of 'Covid' fascism policy on behalf of the Cult in his role as director since 1984 of the National Institute of Allergy and Infectious Diseases (NIAID) while his record of being wrong is laughable; but being wrong, so long as it's the *right kind* of wrong, is why the Cult loves him. He'll say anything the Cult tells him to say. Fauci was made Chief Medical Adviser to the President immediately Biden took office. Biden was installed in the White House by Cult manipulation and one of his first decisions was to elevate Fauci to a position of even more control. This is a coincidence? Yes, and I identify as a flamenco dancer called Lola. How does such an incompetent criminal like Fauci remain in that

pivotal position in American health since *the 1980s*? When you serve the Cult it looks after you until you are surplus to requirements. Kary Mullis said prophetically of Fauci and his like: 'Those guys have an agenda and it's not an agenda we would like them to have ... they make their own rules, they change them when they want to, and Tony Fauci does not mind going on television in front of the people who pay his salary and lie directly into the camera.' Fauci has done that almost daily since the 'Covid' hoax began. Lying is in Fauci's DNA. To make the situation crystal clear about the PCR test this is a direct quote from its inventor Kary Mullis:

It [the PCR test] doesn't tell you that you're sick and doesn't tell you that the thing you ended up with was really going to hurt you ...'

Ask yourself why governments and medical systems the world over have been using this very test to decide who is 'infected' with the SARS-CoV-2 'virus' and the alleged disease it allegedly causes, 'Covid-19'. The answer to that question will tell you what has been going on. By the way, here's a little show-stopper – the 'new' SARS-CoV-2 'virus' was 'identified' as such right from the start using ... *the PCR test not testing for the 'virus'*. If you are new to this and find that shocking then stick around. I have hardly started yet. Even worse, other 'tests', like the 'Lateral Flow Device' (LFD), are considered so useless that they have to be *confirmed* by the PCR test! Leaked emails written by Ben Dyson, adviser to UK 'Health' Secretary Matt Hancock, said they were 'dangerously unreliable'. Dyson, executive director of strategy at the Department of Health, wrote: 'As of today, someone who gets a positive LFD result in (say) London has at best a 25 per cent chance of it being a true positive, but if it is a self-reported test potentially as low as 10 per cent (on an optimistic assumption about specificity) or as low as 2 per cent (on a more pessimistic assumption).' These are the 'tests' that schoolchildren and the public are being urged to have twice a week or more and have to isolate if they get a positive. Each fake positive goes in the statistics as a 'case' no matter how ludicrously inaccurate and the

'cases' drive lockdown, masks and the pressure to 'vaccinate'. The government said in response to the email leak that the 'tests' were accurate which confirmed yet again what shocking bloody liars they are. The real false positive rate is *100 percent* as we'll see. In another 'you couldn't make it up' the UK government agreed to pay £2.8 billion to California's Innova Medical Group to supply the irrelevant lateral flow tests. The company's primary test-making centre is in China. Innova Medical Group, established in March, 2020, is owned by Pasaca Capital Inc, chaired by Chinese-American millionaire Charles Huang who was born in Wuhan.

### **How it works – and how it doesn't**

The RT-PCR test, known by its full title of Polymerase chain reaction, is used across the world to make millions, even billions, of copies of a DNA/RNA genetic information sample. The process is called 'amplification' and means that a tiny sample of genetic material is amplified to bring out the detailed content. I stress that it is not testing for an infectious disease. It is simply amplifying a sample of genetic material. In the words of Kary Mullis: 'PCR is ... just a process that's used to make a whole lot of something out of something.' To emphasise the point companies that make the PCR tests circulated around the world to 'test' for 'Covid' warn on the box that it can't be used to detect 'Covid' or infectious disease and is for research purposes only. It's okay, rest for a minute and you'll be fine. This is the test that produces the 'cases' and 'deaths' that have been used to destroy human society. All those global and national medical and scientific 'experts' demanding this destruction to 'save us' *KNOW* that the test is not testing for the 'virus' and the cases and deaths they claim to be real are an almost unimaginable fraud. Every one of them and so many others including politicians and psychopaths like Gates and Tedros must be brought before Nuremburg-type trials and jailed for the rest of their lives. The more the genetic sample is amplified by PCR the more elements of that material become sensitive to the test and by that I don't mean sensitive for a 'virus' but for elements of the genetic material which

is *naturally* in the body or relates to remnants of old conditions of various kinds lying dormant and causing no disease. Once the amplification of the PCR reaches a certain level *everyone* will test positive. So much of the material has been made sensitive to the test that everyone will have some part of it in their body. Even lying criminals like Fauci have said that once PCR amplifications pass 35 cycles everything will be a false positive that cannot be trusted for the reasons I have described. I say, like many proper doctors and scientists, that 100 percent of the 'positives' are false, but let's just go with Fauci for a moment.

He says that any amplification over 35 cycles will produce false positives and yet the US Centers for Disease Control (CDC) and Food and Drug Administration (FDA) have recommended up to 40 *cycles* and the National Health Service (NHS) in Britain admitted in an internal document for staff that it was using 45 *cycles* of amplification. A long list of other countries has been doing the same and at least one 'testing' laboratory has been using 50 *cycles*. Have you ever heard a doctor, medical 'expert' or the media ask what level of amplification has been used to claim a 'positive'. The 'test' comes back 'positive' and so you have the 'virus', end of story. Now we can see how the government in Tanzania could send off samples from a goat and a pawpaw fruit under human names and both came back positive for 'Covid-19'. Tanzania president John Magufuli mocked the 'Covid' hysteria, the PCR test and masks and refused to import the DNA-manipulating 'vaccine'. The Cult hated him and an article sponsored by the Bill Gates Foundation appeared in the London *Guardian* in February, 2021, headed 'It's time for Africa to rein in Tanzania's anti-vaxxer president'. Well, 'reined in' he shortly was. Magufuli appeared in good health, but then, in March, 2021, he was dead at 61 from 'heart failure'. He was replaced by Samia Hassan Suhulu who is connected to Klaus Schwab's World Economic Forum and she immediately reversed Magufuli's 'Covid' policy. A sample of cola tested positive for 'Covid' with the PCR test in Germany while American actress and singer-songwriter Erykah Badu tested positive in one nostril and negative in the other. Footballer Ronaldo called



the PCR test 'bullshit' after testing positive three times and being forced to quarantine and miss matches when there was nothing wrong with him. The mantra from Tedros at the World Health Organization and national governments (same thing) has been test, test, test. They know that the more tests they can generate the more fake 'cases' they have which go on to become 'deaths' in ways I am coming to. The UK government has its Operation Moonshot planned to test multiple millions every day in workplaces and schools with free tests for everyone to use twice a week at home in line with the Cult plan from the start to make testing part of life. A government advertisement for an 'Interim Head of Asymptomatic Testing Communication' said the job included responsibility for delivering a 'communications strategy' (propaganda) 'to support the expansion of asymptomatic testing that *'normalises testing as part of everyday life'*'. More tests means more fake 'cases', 'deaths' and fascism. I have heard of, and from, many people who booked a test, couldn't turn up, and yet got a positive result through the post for a test they'd never even had. The whole thing is crazy, but for the Cult there's method in the madness. Controlling and manipulating the level of amplification of the test means the authorities can control whenever they want the number of apparent 'cases' and 'deaths'. If they want to justify more fascist lockdown and destruction of livelihoods they keep the amplification high. If they want to give the illusion that lockdowns and the 'vaccine' are working then they lower the amplification and 'cases' and 'deaths' will appear to fall. In January, 2021, the Cult-owned World Health Organization suddenly warned laboratories about over-amplification of the test and to lower the threshold. Suddenly headlines began appearing such as: 'Why ARE "Covid" cases plummeting?' This was just when the vaccine rollout was underway and I had predicted months before they would make cases appear to fall through amplification tampering when the 'vaccine' came. These people are so predictable.

## **Cow vaccines?**

The question must be asked of what is on the test swabs being poked far up the nose of the population to the base of the brain? A nasal swab punctured one woman's brain and caused it to leak fluid. Most of these procedures are being done by people with little training or medical knowledge. Dr Lorraine Day, former orthopaedic trauma surgeon and Chief of Orthopaedic Surgery at San Francisco General Hospital, says the tests are really a 'vaccine'. Cows have long been vaccinated this way. She points out that masks have to cover the nose and the mouth where it is claimed the 'virus' exists in saliva. Why then don't they take saliva from the mouth as they do with a DNA test instead of pushing a long swab up the nose towards the brain? The ethmoid bone separates the nasal cavity from the brain and within that bone is the cribriform plate. Dr Day says that when the swab is pushed up against this plate and twisted the procedure is 'depositing things back there'. She claims that among these 'things' are nanoparticles that can enter the brain. Researchers have noted that a team at the Gates-funded Johns Hopkins have designed tiny, star-shaped micro-devices that can latch onto intestinal mucosa and release drugs into the body. Mucosa is the thin skin that covers the inside surface of parts of the body such as *the nose* and mouth and produces mucus to protect them. The Johns Hopkins micro-devices are called 'theragrippers' and were 'inspired' by a parasitic worm that digs its sharp teeth into a host's intestines. Nasal swabs are also coated in the sterilisation agent ethylene oxide. The US National Cancer Institute posts this explanation on its website:

At room temperature, ethylene oxide is a flammable colorless gas with a sweet odor. It is used primarily to produce other chemicals, including antifreeze. In smaller amounts, ethylene oxide is used as a pesticide and a sterilizing agent. The ability of ethylene oxide to damage DNA makes it an effective sterilizing agent but also accounts for its cancer-causing activity.

The Institute mentions lymphoma and leukaemia as cancers most frequently reported to be associated with occupational exposure to ethylene oxide along with stomach and breast cancers. How does anyone think this is going to work out with the constant testing

regime being inflicted on adults and children at home and at school that will accumulate in the body anything that's on the swab?

## **Doctors know best**

It is vital for people to realise that 'hero' doctors 'know' only what the Big Pharma-dominated medical authorities tell them to 'know' and if they refuse to 'know' what they are told to 'know' they are out the door. They are mostly not physicians or healers, but repeaters of the official narrative – or else. I have seen alleged professional doctors on British television make shocking statements that we are supposed to take seriously. One called 'Dr' Amir Khan, who is actually telling patients how to respond to illness, said that men could take the birth pill to 'help slow down the effects of Covid-19'. In March, 2021, another ridiculous 'Covid study' by an American doctor proposed injecting men with the female sex hormone progesterone as a 'Covid' treatment. British doctor Nighat Arif told the BBC that face coverings were now going to be part of ongoing normal. Yes, the vaccine protects you, she said (evidence?) ... but the way to deal with viruses in the community was always going to come down to hand washing, face covering and keeping a physical distance. That's not what we were told before the 'vaccine' was circulating. Arif said she couldn't imagine ever again going on the underground or in a lift without a mask. I was just thanking my good luck that she was not my doctor when she said – in March, 2021 – that if 'we are *behaving* and we are doing all the right things' she thought we could 'have our nearest and dearest around us at home ... around *Christmas* and *New Year!* Her patronising delivery was the usual school teacher talking to six-year-olds as she repeated every government talking point and probably believed them all. If we have learned anything from the 'Covid' experience surely it must be that humanity's perception of doctors needs a fundamental rethink. NHS 'doctor' Sara Kayat told her television audience that the 'Covid vaccine' would '100 percent prevent hospitalisation and death'. Not even Big Pharma claimed that. We have to stop taking 'experts' at their word without question when so many of them are

clueless and only repeating the party line on which their careers depend. That is not to say there are not brilliant doctors – there are and I have spoken to many of them since all this began – but you won't see them in the mainstream media or quoted by the psychopaths and yes-people in government.

### **Remember the name – Christian Drosten**

German virologist Christian Drosten, Director of Charité Institute of Virology in Berlin, became a national star after the pandemic hoax began. He was feted on television and advised the German government on 'Covid' policy. Most importantly to the wider world Drosten led a group that produced the 'Covid' testing protocol for the PCR test. What a remarkable feat given the PCR cannot test for infectious disease and even more so when you think that Drosten said that his method of testing for SARS-CoV-2 was developed 'without having virus material available'. *He developed a test for a 'virus' that he didn't have and had never seen.* Let that sink in as you survey the global devastation that came from what he did. The whole catastrophe of Drosten's 'test' was based on the alleged genetic sequence published by Chinese scientists on the Internet. We will see in the next chapter that this alleged 'genetic sequence' has never been produced by China or anyone and cannot be when there *is no* SARS-CoV-2. Drosten, however, doesn't seem to let little details like that get in the way. He was the lead author with Victor Corman from the same Charité Hospital of the paper 'Detection of 2019 novel coronavirus (2019-nCoV) by real-time PCR' published in a magazine called *Eurosurveillance*. This became known as the Corman-Drosten paper. In November, 2020, with human society devastated by the effects of the Corman-Drosten test baloney, the protocol was publicly challenged by 22 international scientists and independent researchers from Europe, the United States, and Japan. Among them were senior molecular geneticists, biochemists, immunologists, and microbiologists. They produced a document headed 'External peer review of the RTPCR test to detect SARS-Cov-2 Reveals 10 Major Flaws At The Molecular and Methodological Level: Consequences

For False-Positive Results'. The flaws in the Corman-Drosten test included the following:

- The test is non-specific because of erroneous design
- Results are enormously variable
- The test is unable to discriminate between the whole 'virus' and viral fragments
- It doesn't have positive or negative controls
- The test lacks a standard operating procedure
- It is unsupported by proper peer view

The scientists said the PCR 'Covid' testing protocol was not founded on science and they demanded the Corman-Drosten paper be retracted by *Eurosurveillance*. They said all present and previous Covid deaths, cases, and 'infection rates' should be subject to a massive retroactive inquiry. Lockdowns and travel restrictions should be reviewed and relaxed and those diagnosed through PCR to have 'Covid-19' should not be forced to isolate. Dr Kevin Corbett, a health researcher and nurse educator with a long academic career producing a stream of peer-reviewed publications at many UK universities, made the same point about the PCR test debacle. He said of the scientists' conclusions: 'Every scientific rationale for the development of that test has been totally destroyed by this paper. It's like Hiroshima/Nagasaki to the Covid test.' He said that China hadn't given them an isolated 'virus' when Drosten developed the test. Instead they had developed the test from *a sequence in a gene bank*.' Put another way ... *they made it up!* The scientists were supported in this contention by a Portuguese appeals court which ruled in November, 2020, that PCR tests are unreliable and it is unlawful to quarantine people based solely on a PCR test. The point about China not providing an isolated virus must be true when the 'virus' has never been isolated to this day and the consequences of that will become clear. Drosten and company produced this useless 'protocol' right on cue in January, 2020, just as the 'virus' was said to

be moving westward and it somehow managed to successfully pass a peer-review in 24 hours. In other words there was no peer-review for a test that would be used to decide who had 'Covid' and who didn't across the world. The Cult-created, Gates-controlled World Health Organization immediately recommended all its nearly 200 member countries to use the Drosten PCR protocol to detect 'cases' and 'deaths'. The sting was underway and it continues to this day.

So who is this Christian Drosten that produced the means through which death, destruction and economic catastrophe would be justified? His education background, including his doctoral thesis, would appear to be somewhat shrouded in mystery and his track record is dire as with another essential player in the 'Covid' hoax, the Gates-funded Professor Neil Ferguson at the Gates-funded Imperial College in London of whom more shortly. Drosten predicted in 2003 that the alleged original SARS 'virus' (SARS-1) was an epidemic that could have serious effects on economies and an effective vaccine would take at least two years to produce. Drosten's answer to every alleged 'outbreak' is a vaccine which you won't be shocked to know. What followed were just 774 official deaths worldwide and none in Germany where there were only nine cases. That is even if you believe there ever was a SARS 'virus' when the evidence is zilch and I will expand on this in the next chapter. Drosten claims to be co-discoverer of 'SARS-1' and developed a test for it in 2003. He was screaming warnings about 'swine flu' in 2009 and how it was a widespread infection far more severe than any dangers from a vaccine could be and people should get vaccinated. It would be helpful for Drosten's vocal chords if he simply recorded the words 'the virus is deadly and you need to get vaccinated' and copies could be handed out whenever the latest made-up threat comes along. Drosten's swine flu epidemic never happened, but Big Pharma didn't mind with governments spending hundreds of millions on vaccines that hardly anyone bothered to use and many who did wished they hadn't. A study in 2010 revealed that the risk of dying from swine flu, or H1N1, was no higher than that of the annual seasonal flu which is what at least most of 'it' really was as in

the case of 'Covid-19'. A media investigation into Drosten asked how with such a record of inaccuracy he could be *the* government adviser on these issues. The answer to that question is the same with Drosten, Ferguson and Fauci – they keep on giving the authorities the 'conclusions' and 'advice' they want to hear. Drosten certainly produced the goods for them in January, 2020, with his PCR protocol garbage and provided the foundation of what German internal medicine specialist Dr Claus Köhnlein, co-author of *Virus Mania*, called the 'test pandemic'. The 22 scientists in the *Eurosurveillance* challenge called out conflicts of interest within the Drosten 'protocol' group and with good reason. Olfert Landt, a regular co-author of Drosten 'studies', owns the biotech company TIB Molbiol Syntheselabor GmbH in Berlin which manufactures and sells the tests that Drosten and his mates come up with. They have done this with SARS, Enterotoxigenic E. coli (ETEC), MERS, Zika 'virus', yellow fever, and now 'Covid'. Landt told the *Berliner Zeitung* newspaper:

The testing, design and development came from the Charité [Drosten and Corman]. We simply implemented it immediately in the form of a kit. And if we don't have the virus, which originally only existed in Wuhan, we can make a synthetic gene to simulate the genome of the virus. That's what we did very quickly.

This is more confirmation that the Drosten test was designed without access to the 'virus' and only a synthetic simulation which is what SARS-CoV-2 really is – a computer-generated synthetic fiction. It's quite an enterprise they have going here. A Drosten team decides what the test for something should be and Landt's biotech company flogs it to governments and medical systems across the world. His company must have made an absolute fortune since the 'Covid' hoax began. Dr Reiner Fuellmich, a prominent German consumer protection trial lawyer in Germany and California, is on Drosten's case and that of Tedros at the World Health Organization for crimes against humanity with a class-action lawsuit being prepared in the United States and other legal action in Germany.

## Why China?

Scamming the world with a 'virus' that doesn't exist would seem impossible on the face of it, but not if you have control of the relatively few people that make policy decisions and the great majority of the global media. Remember it's not about changing 'real' reality it's about controlling *perception* of reality. You don't have to make something happen you only have to make people *believe* that it's happening. Renegade Minds understand this and are therefore much harder to swindle. 'Covid-19' is not a 'real' 'virus'. It's a mind virus, like a computer virus, which has infected the minds, not the bodies, of billions. It all started, publically at least, in China and that alone is of central significance. The Cult was behind the revolution led by its asset Mao Zedong, or Chairman Mao, which established the People's Republic of China on October 1st, 1949. It should have been called The Cult's Republic of China, but the name had to reflect the recurring illusion that vicious dictatorships are run by and for the people (see all the 'Democratic Republics' controlled by tyrants). In the same way we have the 'Biden' Democratic Republic of America officially ruled by a puppet tyrant (at least temporarily) on behalf of Cult tyrants. The creation of Mao's merciless communist/fascist dictatorship was part of a frenzy of activity by the Cult at the conclusion of World War Two which, like the First World War, it had instigated through its assets in Germany, Britain, France, the United States and elsewhere. Israel was formed in 1948; the Soviet Union expanded its 'Iron Curtain' control, influence and military power with the Warsaw Pact communist alliance in 1955; the United Nations was formed in 1945 as a Cult precursor to world government; and a long list of world bodies would be established including the World Health Organization (1948), World Trade Organization (1948 under another name until 1995), International Monetary Fund (1945) and World Bank (1944). Human society was redrawn and hugely centralised in the global Problem-Reaction-Solution that was World War Two. All these changes were significant. Israel would become the headquarters of the Sabbatians



and the revolution in China would prepare the ground and control system for the events of 2019/2020.

Renegade Minds know there are no borders except for public consumption. The Cult is a seamless, borderless global entity and to understand the game we need to put aside labels like borders, nations, countries, communism, fascism and democracy. These delude the population into believing that countries are ruled within their borders by a government of whatever shade when these are mere agencies of a global power. America's illusion of democracy and China's communism/fascism are subsidiaries – vehicles – for the same agenda. We may hear about conflict and competition between America and China and on the lower levels that will be true; but at the Cult level they are branches of the same company in the way of the McDonald's example I gave earlier. I have tracked in the books over the years support by US governments of both parties for Chinese Communist Party infiltration of American society through allowing the sale of land, even military facilities, and the acquisition of American business and university influence. All this is underpinned by the infamous stealing of intellectual property and technological know-how. Cult-owned Silicon Valley corporations waive their fraudulent 'morality' to do business with human-rights-free China; Cult-controlled Disney has become China's PR department; and China in effect owns 'American' sports such as basketball which depends for much of its income on Chinese audiences. As a result any sports player, coach or official speaking out against China's horrific human rights record is immediately condemned or fired by the China-worshipping National Basketball Association. One of the first acts of China-controlled Biden was to issue an executive order telling federal agencies to stop making references to the 'virus' by the 'geographic location of its origin'. Long-time Congressman Jerry Nadler warned that criticising China, America's biggest rival, leads to hate crimes against Asian people in the United States. So shut up you bigot. China is fast closing in on Israel as a country that must not be criticised which is apt, really, given that Sabbatians control them both. The two countries have

developed close economic, military, technological and strategic ties which include involvement in China's 'Silk Road' transport and economic initiative to connect China with Europe. Israel was the first country in the Middle East to recognise the establishment of Mao's tyranny in 1950 months after it was established.

### **Project Wuhan – the 'Covid' Psyop**

I emphasise again that the Cult plays the long game and what is happening to the world today is the result of centuries of calculated manipulation following a script to take control step-by-step of every aspect of human society. I will discuss later the common force behind all this that has spanned those centuries and thousands of years if the truth be told. Instigating the Mao revolution in China in 1949 with a 2020 'pandemic' in mind is not only how they work – the 71 years between them is really quite short by the Cult's standards of manipulation preparation. The reason for the Cult's Chinese revolution was to create a fiercely-controlled environment within which an extreme structure for human control could be incubated to eventually be unleashed across the world. We have seen this happen since the 'pandemic' emerged from China with the Chinese control-structure founded on AI technology and tyrannical enforcement sweep across the West. Until the moment when the Cult went for broke in the West and put its fascism on public display Western governments had to pay some lip-service to freedom and democracy to not alert too many people to the tyranny-in-the-making. Freedoms were more subtly eroded and power centralised with covert government structures put in place waiting for the arrival of 2020 when that smokescreen of 'freedom' could be dispensed with. The West was not able to move towards tyranny before 2020 anything like as fast as China which was created as a tyranny and had no limits on how fast it could construct the Cult's blueprint for global control. When the time came to impose that structure on the world it was the same Cult-owned Chinese communist/fascist government that provided the excuse – the 'Covid pandemic'. It was absolutely crucial to the Cult plan for the Chinese response to the 'pandemic' –

draconian lockdowns of the entire population – to become the blueprint that Western countries would follow to destroy the livelihoods and freedom of their people. This is why the Cult-owned, Gates-owned, WHO Director-General Tedros said early on:

The Chinese government is to be congratulated for the extraordinary measures it has taken to contain the outbreak. China is actually setting a new standard for outbreak response and it is not an exaggeration.

*Forbes* magazine said of China: ‘... those measures protected untold millions from getting the disease’. The Rockefeller Foundation ‘epidemic scenario’ document in 2010 said ‘prophetically’:

However, a few countries did fare better – China in particular. The Chinese government’s quick imposition and enforcement of mandatory quarantine for all citizens, as well as its instant and near-hermetic sealing off of all borders, saved millions of lives, stopping the spread of the virus far earlier than in other countries and enabling a swifter post-pandemic recovery.

Once again – *spooky*.

The first official story was the ‘bat theory’ or rather the bat diversion. The source of the ‘virus outbreak’ we were told was a ‘wet market’ in Wuhan where bats and other animals are bought and eaten in horrifically unhygienic conditions. Then another story emerged through the alternative media that the ‘virus’ had been released on purpose or by accident from a BSL-4 (biosafety level 4) laboratory in Wuhan not far from the wet market. The lab was reported to create and work with lethal concoctions and bioweapons. Biosafety level 4 is the highest in the World Health Organization system of safety and containment. Renegade Minds are aware of what I call designer manipulation. The ideal for the Cult is for people to buy its prime narrative which in the opening salvos of the ‘pandemic’ was the wet market story. It knows, however, that there is now a considerable worldwide alternative media of researchers sceptical of anything governments say and they are often given a version of events in a form they can perceive as credible while misdirecting them from the real truth. In this case let them

think that the conspiracy involved is a 'bioweapon virus' released from the Wuhan lab to keep them from the real conspiracy – *there is no 'virus'*. The WHO's current position on the source of the outbreak at the time of writing appears to be: 'We haven't got a clue, mate.' This is a good position to maintain mystery and bewilderment. The inner circle will know where the 'virus' came from – *nowhere*. The bottom line was to ensure the public believed there *was* a 'virus' and it didn't much matter if they thought it was natural or had been released from a lab. The belief that there was a 'deadly virus' was all that was needed to trigger global panic and fear. The population was terrified into handing their power to authority and doing what they were told. They had to or they were 'all gonna die'.

In March, 2020, information began to come my way from real doctors and scientists and my own additional research which had my intuition screaming: 'Yes, that's it! *There is no virus.*' The 'bioweapon' was not the 'virus'; it was the '*vaccine*' already being talked about that would be the bioweapon. My conclusion was further enhanced by happenings in Wuhan. The 'virus' was said to be sweeping the city and news footage circulated of people collapsing in the street (which they've never done in the West with the same 'virus'). The Chinese government was building 'new hospitals' in a matter of ten days to 'cope with demand' such was the virulent nature of the 'virus'. Yet in what seemed like no time the 'new hospitals' closed – even if they even opened – and China declared itself 'virus-free'. It was back to business as usual. This was more propaganda to promote the Chinese draconian lockdowns in the West as the way to 'beat the virus'. Trouble was that we subsequently had lockdown after lockdown, but never business as usual. As the people of the West and most of the rest of the world were caught in an ever-worsening spiral of lockdown, social distancing, masks, isolated old people, families forced apart, and livelihood destruction, it was party-time in Wuhan. Pictures emerged of thousands of people enjoying pool parties and concerts. It made no sense until you realised there never was a 'virus' and the

whole thing was a Cult set-up to transform human society out of one of its major global strongholds – China.

How is it possible to deceive virtually the entire world population into believing there is a deadly virus when there is not even a 'virus' let alone a deadly one? It's nothing like as difficult as you would think and that's clearly true because it happened.

**Postscript:** See end of book Postscript for more on the 'Wuhan lab virus release' story which the authorities and media were pushing heavily in the summer of 2021 to divert attention from the truth that the 'Covid virus' is pure invention.

## CHAPTER FIVE

### ***There is no 'virus'***

*You can fool some of the people all of the time, and all of the people some of the time, but you cannot fool all of the people all of the time*

Abraham Lincoln

The greatest form of mind control is repetition. The more you repeat the same mantra of alleged 'facts' the more will accept them to be true. It becomes an 'everyone knows that, mate'. If you can also censor any other version or alternative to your alleged 'facts' you are pretty much home and cooking.

By the start of 2020 the Cult owned the global mainstream media almost in its entirety to spew out its 'Covid' propaganda and ignore or discredit any other information and view. Cult-owned social media platforms in Cult-owned Silicon Valley were poised and ready to unleash a campaign of ferocious censorship to obliterate all but the official narrative. To complete the circle many demands for censorship by Silicon Valley were led by the mainstream media as 'journalists' became full-out enforcers for the Cult both as propagandists and censors. Part of this has been the influx of young people straight out of university who have become 'journalists' in significant positions. They have no experience and a headful of programmed perceptions from their years at school and university at a time when today's young are the most perceptually-targeted generations in known human history given the insidious impact of technology. They enter the media perceptually prepared and ready to repeat the narratives of the system that programmed them to

repeat its narratives. The BBC has a truly pathetic 'specialist disinformation reporter' called Marianna Spring who fits this bill perfectly. She is clueless about the world, how it works and what is really going on. Her role is to discredit anyone doing the job that a proper journalist would do and system-serving hacks like Spring wouldn't dare to do or even see the need to do. They are too busy licking the arse of authority which can never be wrong and, in the case of the BBC propaganda programme, *Panorama*, contacting payments systems such as PayPal to have a donations page taken down for a film company making documentaries questioning vaccines. Even the BBC soap opera *EastEnders* included a disgracefully biased scene in which an inarticulate white working class woman was made to look foolish for questioning the 'vaccine' while a well-spoken black man and Asian woman promoted the government narrative. It ticked every BBC box and the fact that the black and minority community was resisting the 'vaccine' had nothing to do with the way the scene was written. The BBC has become a disgusting tyrannical propaganda and censorship operation that should be defunded and disbanded and a free media take its place with a brief to stop censorship instead of demanding it. A BBC 'interview' with Gates goes something like: 'Mr Gates, sir, if I can call you sir, would you like to tell our audience why you are such a great man, a wonderful humanitarian philanthropist, and why you should absolutely be allowed as a software salesman to decide health policy for approaching eight billion people? Thank you, sir, please sir.' Propaganda programming has been incessant and merciless and when all you hear is the same story from the media, repeated by those around you who have only heard the same story, is it any wonder that people on a grand scale believe absolute mendacious garbage to be true? You are about to see, too, why this level of information control is necessary when the official 'Covid' narrative is so nonsensical and unsupportable by the evidence.

## **Structure of Deceit**

The pyramid structure through which the 'Covid' hoax has been manifested is very simple and has to be to work. As few people as possible have to be involved with full knowledge of what they are doing – and why – or the real story would get out. At the top of the pyramid are the inner core of the Cult which controls Bill Gates who, in turn, controls the World Health Organization through his pivotal funding and his puppet Director-General mouthpiece, Tedros. Before he was appointed Tedros was chair of the Gates-founded Global Fund to 'fight against AIDS, tuberculosis and malaria', a board member of the Gates-funded 'vaccine alliance' GAVI, and on the board of another Gates-funded organisation. Gates owns him and picked him for a specific reason – Tedros is a crook and worse. 'Dr' Tedros (he's not a medical doctor, the first WHO chief not to be) was a member of the tyrannical Marxist government of Ethiopia for decades with all its human rights abuses. He has faced allegations of corruption and misappropriation of funds and was exposed three times for covering up cholera epidemics while Ethiopia's health minister. Tedros appointed the mass-murdering genocidal Zimbabwe dictator Robert Mugabe as a WHO goodwill ambassador for public health which, as with Tedros, is like appointing a psychopath to run a peace and love campaign. The move was so ridiculous that he had to drop Mugabe in the face of widespread condemnation. American economist David Steinman, a Nobel peace prize nominee, lodged a complaint with the International Criminal Court in The Hague over alleged genocide by Tedros when he was Ethiopia's foreign minister. Steinman says Tedros was a 'crucial decision maker' who directed the actions of Ethiopia's security forces from 2013 to 2015 and one of three officials in charge when those security services embarked on the 'killing' and 'torturing' of Ethiopians. You can see where Tedros is coming from and it's sobering to think that he has been the vehicle for Gates and the Cult to direct the global response to 'Covid'. Think about that. A psychopathic Cult dictates to psychopath Gates who dictates to psychopath Tedros who dictates how countries of the world must respond to a 'Covid virus' never scientifically shown to exist. At the same time psychopathic Cult-owned Silicon Valley information



giants like Google, YouTube, Facebook and Twitter announced very early on that they would give the Cult/Gates/Tedros/WHO version of the narrative free advertising and censor those who challenged their intelligence-insulting, mendacious story.

The next layer in the global 'medical' structure below the Cult, Gates and Tedros are the chief medical officers and science 'advisers' in each of the WHO member countries which means virtually all of them. Medical officers and arbiters of science (they're not) then take the WHO policy and recommended responses and impose them on their country's population while the political 'leaders' say they are deciding policy (they're clearly not) by 'following the science' on the advice of the 'experts' – the same medical officers and science 'advisers' (dictators). In this way with the rarest of exceptions the entire world followed the same policy of lockdown, people distancing, masks and 'vaccines' dictated by the psychopathic Cult, psychopathic Gates and psychopathic Tedros who we are supposed to believe give a damn about the health of the world population they are seeking to enslave. That, amazingly, is all there is to it in terms of crucial decision-making. Medical staff in each country then follow like sheep the dictates of the shepherds at the top of the national medical hierarchies – chief medical officers and science 'advisers' who themselves follow like sheep the shepherds of the World Health Organization and the Cult. Shepherds at the national level often have major funding and other connections to Gates and his Bill and Melinda Gates Foundation which carefully hands out money like confetti at a wedding to control the entire global medical system from the WHO down.

### **Follow the money**

Christopher Whitty, Chief Medical Adviser to the UK Government at the centre of 'virus' policy, a senior adviser to the government's Scientific Advisory Group for Emergencies (SAGE), and Executive Board member of the World Health Organization, was gifted a grant of \$40 million by the Bill and Melinda Gates Foundation for malaria research in Africa. The BBC described the unelected Whitty as 'the

official who will probably have the greatest impact on our everyday lives of any individual policymaker in modern times' and so it turned out. What Gates and Tedros have said Whitty has done like his equivalents around the world. Patrick Vallance, co-chair of SAGE and the government's Chief Scientific Adviser, is a former executive of Big Pharma giant GlaxoSmithKline with its fundamental financial and business connections to Bill Gates. In September, 2020, it was revealed that Vallance owned a deferred bonus of shares in GlaxoSmithKline worth £600,000 while the company was 'developing' a 'Covid vaccine'. Move along now – nothing to see here – what could possibly be wrong with that? Imperial College in London, a major player in 'Covid' policy in Britain and elsewhere with its 'Covid-19' Response Team, is funded by Gates and has big connections to China while the now infamous Professor Neil Ferguson, the useless 'computer modeller' at Imperial College is also funded by Gates. Ferguson delivered the dramatically inaccurate excuse for the first lockdowns (much more in the next chapter). The Institute for Health Metrics and Evaluation (IHME) in the United States, another source of outrageously false 'Covid' computer models to justify lockdowns, is bankrolled by Gates who is a vehement promotor of lockdowns. America's version of Whitty and Vallance, the again now infamous Anthony Fauci, has connections to 'Covid vaccine' maker Moderna as does Bill Gates through funding from the Bill and Melinda Gates Foundation. Fauci is director of the National Institute of Allergy and Infectious Diseases (NIAID), a major recipient of Gates money, and they are very close. Deborah Birx who was appointed White House Coronavirus Response Coordinator in February, 2020, is yet another with ties to Gates. Everywhere you look at the different elements around the world behind the coordination and decision making of the 'Covid' hoax there is Bill Gates and his money. They include the World Health Organization; Centers for Disease Control (CDC) in the United States; National Institutes of Health (NIH) of Anthony Fauci; Imperial College and Neil Ferguson; the London School of Hygiene where Chris Whitty worked; Regulatory agencies like the UK Medicines & Healthcare products Regulatory Agency (MHRA)

which gave emergency approval for 'Covid vaccines'; Wellcome Trust; GAVI, the Vaccine Alliance; the Coalition for Epidemic Preparedness Innovations (CEPI); Johns Hopkins University which has compiled the false 'Covid' figures; and the World Economic Forum. A [Nationalfile.com](http://Nationalfile.com) article said:

Gates has a lot of pull in the medical world, he has a multi-million dollar relationship with Dr. Fauci, and Fauci originally took the Gates line supporting vaccines and casting doubt on [the drug hydroxychloroquine]. Coronavirus response team member Dr. Deborah Birx, appointed by former president Obama to serve as United States Global AIDS Coordinator, also sits on the board of a group that has received billions from Gates' foundation, and Birx reportedly used a disputed Bill Gates-funded model for the White House's Coronavirus effort. Gates is a big proponent for a population lockdown scenario for the Coronavirus outbreak.

Another funder of Moderna is the Defense Advanced Research Projects Agency (DARPA), the technology-development arm of the Pentagon and one of the most sinister organisations on earth. DARPA had a major role with the CIA covert technology-funding operation In-Q-Tel in the development of Google and social media which is now at the centre of global censorship. Fauci and Gates are extremely close and openly admit to talking regularly about 'Covid' policy, but then why wouldn't Gates have a seat at every national 'Covid' table after his Foundation committed \$1.75 billion to the 'fight against Covid-19'. When passed through our Orwellian Translation Unit this means that he has bought and paid for the Cult-driven 'Covid' response worldwide. Research the major 'Covid' response personnel in your own country and you will find the same Gates funding and other connections again and again. Medical and science chiefs following World Health Organization 'policy' sit atop a medical hierarchy in their country of administrators, doctors and nursing staff. These 'subordinates' are told they must work and behave in accordance with the policy delivered from the 'top' of the national 'health' pyramid which is largely the policy delivered by the WHO which is the policy delivered by Gates and the Cult. The whole 'Covid' narrative has been imposed on medical staff by a climate of fear although great numbers don't even need that to comply. They do so through breathtaking levels of ignorance and

include doctors who go through life simply repeating what Big Pharma and their hierarchical masters tell them to say and believe. No wonder Big Pharma 'medicine' is one of the biggest killers on Planet Earth.

The same top-down system of intimidation operates with regard to the Cult Big Pharma cartel which also dictates policy through national and global medical systems in this way. The Cult and Big Pharma agendas are the same because the former controls and owns the latter. 'Health' administrators, doctors, and nursing staff are told to support and parrot the dictated policy or they will face consequences which can include being fired. How sad it's been to see medical staff meekly repeating and imposing Cult policy without question and most of those who can see through the deceit are only willing to speak anonymously off the record. They know what will happen if their identity is known. This has left the courageous few to expose the lies about the 'virus', face masks, overwhelmed hospitals that aren't, and the dangers of the 'vaccine' that isn't a vaccine. When these medical professionals and scientists, some renowned in their field, have taken to the Internet to expose the truth their articles, comments and videos have been deleted by Cult-owned Facebook, Twitter and YouTube. What a real head-shaker to see YouTube videos with leading world scientists and highly qualified medical specialists with an added link underneath to the notorious Cult propaganda website *Wikipedia* to find the 'facts' about the same subject.

### **HIV – the 'Covid' trial-run**

I'll give you an example of the consequences for health and truth that come from censorship and unquestioning belief in official narratives. The story was told by PCR inventor Kary Mullis in his book *Dancing Naked in the Mind Field*. He said that in 1984 he accepted as just another scientific fact that Luc Montagnier of France's Pasteur Institute and Robert Gallo of America's National Institutes of Health had independently discovered that a 'retrovirus' dubbed HIV (human immunodeficiency virus) caused AIDS. They

were, after all, Mullis writes, specialists in retroviruses. This is how the medical and science pyramids work. Something is announced or *assumed* and then becomes an everybody-knows-that purely through repetition of the assumption as if it is fact. Complete crap becomes accepted truth with no supporting evidence and only repetition of the crap. This is how a 'virus' that doesn't exist became the 'virus' that changed the world. The HIV-AIDS fairy story became a multi-billion pound industry and the media poured out propaganda terrifying the world about the deadly HIV 'virus' that caused the lethal AIDS. By then Mullis was working at a lab in Santa Monica, California, to detect retroviruses with his PCR test in blood donations received by the Red Cross. In doing so he asked a virologist where he could find a reference for HIV being the cause of AIDS. 'You don't need a reference,' the virologist said ... '*Everybody knows it.*' Mullis said he wanted to quote a reference in the report he was doing and he said he felt a little funny about not knowing the source of such an important discovery when everyone else seemed to. The virologist suggested he cite a report by the Centers for Disease Control and Prevention (CDC) on morbidity and mortality. Mullis read the report, but it only said that an organism had been identified and did not say how. The report did not identify the original scientific work. Physicians, however, *assumed* (key recurring theme) that if the CDC was convinced that HIV caused AIDS then proof must exist. Mullis continues:

I did computer searches. Neither Montagnier, Gallo, nor anyone else had published papers describing experiments which led to the conclusion that HIV probably caused AIDS. I read the papers in *Science* for which they had become well known as AIDS doctors, but all they had said there was that they had found evidence of a past infection by something which was probably HIV in some AIDS patients.

They found antibodies. Antibodies to viruses had always been considered evidence of past disease, not present disease. Antibodies signaled that the virus had been defeated. The patient had saved himself. There was no indication in these papers that this virus caused a disease. They didn't show that everybody with the antibodies had the disease. In fact they found some healthy people with antibodies.

Mullis asked why their work had been published if Montagnier and Gallo hadn't really found this evidence, and why had they been fighting so hard to get credit for the discovery? He says he was hesitant to write 'HIV is the probable cause of AIDS' until he found published evidence to support that. 'Tens of thousands of scientists and researchers were spending billions of dollars a year doing research based on this idea,' Mullis writes. 'The reason had to be there somewhere; otherwise these people would not have allowed their research to settle into one narrow channel of investigation.' He said he lectured about PCR at numerous meetings where people were always talking about HIV and he asked them how they knew that HIV was the cause of AIDS:

Everyone said something. Everyone had the answer at home, in the office, in some drawer. They all knew, and they would send me the papers as soon as they got back. But I never got any papers. Nobody ever sent me the news about how AIDS was caused by HIV.

Eventually Mullis was able to ask Montagnier himself about the reference proof when he lectured in San Diego at the grand opening of the University of California AIDS Research Center. Mullis says this was the last time he would ask his question without showing anger. Montagnier said he should reference the CDC report. 'I read it', Mullis said, and it didn't answer the question. 'If Montagnier didn't know the answer who the hell did?' Then one night Mullis was driving when an interview came on National Public Radio with Peter Duesberg, a prominent virologist at Berkeley and a California Scientist of the Year. Mullis says he finally understood why he could not find references that connected HIV to AIDS – *there weren't any!* No one had ever proved that HIV causes AIDS even though it had spawned a multi-billion pound global industry and the media was repeating this as fact every day in their articles and broadcasts terrifying the shit out of people about AIDS and giving the impression that a positive test for HIV (see 'Covid') was a death sentence. Duesberg was a threat to the AIDS gravy train and the agenda that underpinned it. He was therefore abused and castigated after he told the Proceedings of the National Academy of Sciences

there was no good evidence implicating the new 'virus'. Editors rejected his manuscripts and his research funds were deleted. Mullis points out that the CDC has defined AIDS as one of more than 30 diseases *if accompanied* by a positive result on a test that detects antibodies to HIV; but those same diseases are not defined as AIDS cases when antibodies are not detected:

If an HIV-positive woman develops uterine cancer, for example, she is considered to have AIDS. If she is not HIV positive, she simply has uterine cancer. An HIV-positive man with tuberculosis has AIDS; if he tests negative he simply has tuberculosis. If he lives in Kenya or Colombia, where the test for HIV antibodies is too expensive, he is simply presumed to have the antibodies and therefore AIDS, and therefore he can be treated in the World Health Organization's clinic. It's the only medical help available in some places. And it's free, because the countries that support WHO are worried about AIDS.

Mullis accuses the CDC of continually adding new diseases (see ever more 'Covid symptoms') to the grand AIDS definition and of virtually doctoring the books to make it appear as if the disease continued to spread. He cites how in 1993 the CDC enormously broadened its AIDS definition and county health authorities were delighted because they received \$2,500 per year from the Federal government for every reported AIDS case. Ladies and gentlemen, I have just described, via Kary Mullis, the 'Covid pandemic' of 2020 and beyond. Every element is the same and it's been pulled off in the same way by the same networks.

### **The 'Covid virus' exists? Okay – prove it. Er ... still waiting**

What Kary Mullis described with regard to 'HIV' has been repeated with 'Covid'. A claim is made that a new, or 'novel', infection has been found and the entire medical system of the world repeats that as fact exactly as they did with HIV and AIDS. No one in the mainstream asks rather relevant questions such as 'How do you know?' and 'Where is your proof?' The SARS-Cov-2 'virus' and the 'Covid-19 disease' became an overnight 'everybody-knows-that'. The origin could be debated and mulled over, but what you could not suggest was that 'SARS-Cov-2' didn't exist. That would be

ridiculous. 'Everybody knows' the 'virus' exists. Well, I didn't for one along with American proper doctors like Andrew Kaufman and Tom Cowan and long-time American proper journalist Jon Rappaport. We dared to pursue the obvious and simple question: 'Where's the evidence?' The overwhelming majority in medicine, journalism and the general public did not think to ask that. After all, *everyone knew* there was a new 'virus'. Everyone was saying so and I heard it on the BBC. Some would eventually argue that the 'deadly virus' was nothing like as deadly as claimed, but few would venture into the realms of its very existence. Had they done so they would have found that the evidence for that claim had gone AWOL as with HIV causes AIDS. In fact, not even that. For something to go AWOL it has to exist in the first place and scientific proof for a 'SARS-Cov-2' can be filed under nothing, nowhere and zilch.

Dr Andrew Kaufman is a board-certified forensic psychiatrist in New York State, a Doctor of Medicine and former Assistant Professor and Medical Director of Psychiatry at SUNY Upstate Medical University, and Medical Instructor of Hematology and Oncology at the Medical School of South Carolina. He also studied biology at the Massachusetts Institute of Technology (MIT) and trained in Psychiatry at Duke University. Kaufman is retired from allopathic medicine, but remains a consultant and educator on natural healing, I saw a video of his very early on in the 'Covid' hoax in which he questioned claims about the 'virus' in the absence of any supporting evidence and with plenty pointing the other way. I did everything I could to circulate his work which I felt was asking the pivotal questions that needed an answer. I can recommend an excellent pull-together interview he did with the website The Last Vagabond entitled *Dr Andrew Kaufman: Virus Isolation, Terrain Theory and Covid-19* and his website is [andrewkaufmanmd.com](http://andrewkaufmanmd.com). Kaufman is not only a forensic psychiatrist; he is forensic in all that he does. He always reads original scientific papers, experiments and studies instead of second-third-fourth-hand reports about the 'virus' in the media which are repeating the repeated repetition of the narrative. When he did so with the original Chinese 'virus' papers Kaufman



realised that there was no evidence of a 'SARS-Cov-2'. They had never – from the start – shown it to exist and every repeat of this claim worldwide was based on the accepted existence of proof that was nowhere to be found – see Kary Mullis and HIV. Here we go again.

## **Let's postulate**

Kaufman discovered that the Chinese authorities immediately concluded that the cause of an illness that broke out among about 200 initial patients in Wuhan was a 'new virus' when there were no grounds to make that conclusion. The alleged 'virus' was not isolated from other genetic material in their samples and then shown through a system known as Koch's postulates to be the causative agent of the illness. The world was told that the SARS-Cov-2 'virus' caused a disease they called 'Covid-19' which had 'flu-like' symptoms and could lead to respiratory problems and pneumonia. If it wasn't so tragic it would almost be funny. *'Flu-like' symptoms? Pneumonia? Respiratory disease?* What in CHINA and particularly in Wuhan, one of the most polluted cities in the world with a resulting epidemic of respiratory disease?? Three hundred thousand people get pneumonia in China every year and there are nearly a billion cases worldwide of 'flu-like symptoms'. These have a whole range of causes – including pollution in Wuhan – but no other possibility was credibly considered in late 2019 when the world was told there was a new and deadly 'virus'. The global prevalence of pneumonia and 'flu-like systems' gave the Cult networks unlimited potential to re-diagnose these other causes as the mythical 'Covid-19' and that is what they did from the very start. Kaufman revealed how Chinese medical and science authorities (all subordinates to the Cult-owned communist government) took genetic material from the lungs of only a few of the first patients. The material contained their own cells, bacteria, fungi and other microorganisms living in their bodies. The only way you could prove the existence of the 'virus' and its responsibility for the alleged 'Covid-19' was to isolate the virus from all the other material – a process also known as 'purification' – and

then follow the postulates sequence developed in the late 19th century by German physician and bacteriologist Robert Koch which became the 'gold standard' for connecting an alleged causation agent to a disease:

1. The microorganism (bacteria, fungus, virus, etc.) must be present in every case of the disease and all patients must have the same symptoms. It must also *not be present in healthy individuals*.
2. The microorganism must be isolated from the host with the disease. If the microorganism is a bacteria or fungus it must be grown in a pure culture. If it is a virus, it must be purified (i.e. containing no other material except the virus particles) from a clinical sample.
3. The specific disease, with all of its characteristics, must be reproduced when the infectious agent (the purified virus or a pure culture of bacteria or fungi) is inoculated into a healthy, susceptible host.
4. The microorganism must be recoverable from the experimentally infected host as in step 2.

*Not one* of these criteria has been met in the case of 'SARS-Cov-2' and 'Covid-19'. Not ONE. EVER. Robert Koch refers to bacteria and not viruses. What are called 'viral particles' are so minute (hence masks are useless by any definition) that they could only be seen after the invention of the electron microscope in the 1930s and can still only be observed through that means. American bacteriologist and virologist Thomas Milton Rivers, the so-called 'Father of Modern Virology' who was very significantly director of the Rockefeller Institute for Medical Research in the 1930s, developed a less stringent version of Koch's postulates to identify 'virus' causation known as 'Rivers criteria'. 'Covid' did not pass that process either. Some even doubt whether any 'virus' can be isolated from other particles containing genetic material in the Koch method. Freedom of Information requests in many countries asking for scientific proof that the 'Covid virus' has been purified and isolated and shown to exist have all come back with a 'we don't have that' and when this happened with a request to the UK Department of Health they added this comment:

However, outside of the scope of the [Freedom of Information Act] and on a discretionary basis, the following information has been advised to us, which may be of interest. Most infectious diseases are caused by viruses, bacteria or fungi. Some bacteria or fungi have the capacity to grow on their own in isolation, for example in colonies on a petri dish. Viruses are different in that they are what we call 'obligate pathogens' – that is, they cannot survive or reproduce without infecting a host ...

... For some diseases, it is possible to establish causation between a microorganism and a disease by isolating the pathogen from a patient, growing it in pure culture and reintroducing it to a healthy organism. These are known as 'Koch's postulates' and were developed in 1882. However, as our understanding of disease and different disease-causing agents has advanced, these are no longer the method for determining causation [Andrew Kaufman asks why in that case are there two published articles falsely claiming to satisfy Koch's postulates].

It has long been known that viral diseases cannot be identified in this way as viruses cannot be grown in 'pure culture'. When a patient is tested for a viral illness, this is normally done by looking for the presence of antigens, or viral genetic code in a host with molecular biology techniques [Kaufman asks how you could know the origin of these chemicals without having a pure culture for comparison].

For the record 'antigens' are defined so:

Invading microorganisms have antigens on their surface that the human body can recognise as being foreign – meaning not belonging to it. When the body recognises a foreign antigen, lymphocytes (white blood cells) produce antibodies, which are complementary in shape to the antigen.

Notwithstanding that this is open to question in relation to 'SARS-Cov-2' the presence of 'antibodies' can have many causes and they are found in people that are perfectly well. Kary Mullis said: 'Antibodies ... had always been considered evidence of past disease, not present disease.'

### **'Covid' really is a *computer* 'virus'**

Where the UK Department of Health statement says 'viruses' are now 'diagnosed' through a 'viral genetic code in a host with molecular biology techniques', they mean ... *the PCR test* which its inventor said cannot test for infectious disease. They have no credible method of connecting a 'virus' to a disease and we will see that there is no scientific proof that any 'virus' causes any disease or there is any such thing as a 'virus' in the way that it is described. Tenacious Canadian researcher Christine Massey and her team made

some 40 Freedom of Information requests to national public health agencies in different countries asking for proof that SARS-CoV-2 has been isolated and not one of them could supply that information. Massey said of her request in Canada: 'Freedom of Information reveals Public Health Agency of Canada has no record of 'SARS-COV-2' isolation performed by anyone, anywhere, ever.' If you accept the comment from the UK Department of Health it's because they can't isolate a 'virus'. Even so many 'science' papers claimed to have isolated the 'Covid virus' until they were questioned and had to admit they hadn't. A reply from the Robert Koch Institute in Germany was typical: 'I am not aware of a paper which purified isolated SARS-CoV-2.' So what the hell was Christian Drosten and his gang using to design the 'Covid' testing protocol that has produced all the illusory Covid' cases and 'Covid' deaths when the head of the Chinese version of the CDC admitted there was a problem right from the start in that the 'virus' had never been isolated/purified? Breathe deeply: What they are calling 'Covid' is actually created by a *computer program* i.e. *they made it up* – er, that's it. They took lung fluid, with many sources of genetic material, from one single person alleged to be infected with Covid-19 by a PCR test which they *claimed*, without clear evidence, contained a 'virus'. They used several computer programs to create a model of a theoretical virus genome sequence from more than fifty-six million small sequences of RNA, each of an unknown source, assembling them like a puzzle with no known solution. The computer filled in the gaps with sequences from bits in the gene bank to make it look like a bat SARS-like coronavirus! A wave of the magic wand and poof, an *in silico* (computer-generated) genome, a scientific fantasy, was created. UK health researcher Dr Kevin Corbett made the same point with this analogy:

... It's like giving you a few bones and saying that's your fish. It could be any fish. Not even a skeleton. Here's a few fragments of bones. That's your fish ... It's all from gene bank and the bits of the virus sequence that weren't there they made up.

They synthetically created them to fill in the blanks. That's what genetics is; it's a code. So it's ABBCCDDDD and you're missing some what you think is EEE so you put it in. It's all

synthetic. You just manufacture the bits that are missing. This is the end result of the geneticization of virology. This is basically a computer virus.

Further confirmation came in an email exchange between British citizen journalist Frances Leader and the government's Medicines & Healthcare Products Regulatory Agency (the Gates-funded MHRA) which gave emergency permission for untested 'Covid vaccines' to be used. The agency admitted that the 'vaccine' is not based on an isolated 'virus', but comes from a *computer-generated model*. Frances Leader was naturally banned from Cult-owned fascist Twitter for making this exchange public. The process of creating computer-generated alleged 'viruses' is called 'in silico' or 'in silicon' – computer chips – and the term 'in silico' is believed to originate with biological experiments using only a computer in 1989. 'Vaccines' involved with 'Covid' are also produced 'in silico' or by computer not a natural process. If the original 'virus' is nothing more than a made-up computer model how can there be 'new variants' of something that never existed in the first place? They are not new 'variants'; they are new *computer models* only minutely different to the original program and designed to further terrify the population into having the 'vaccine' and submitting to fascism. You want a 'new variant'? Click, click, enter – there you go. Tell the medical profession that you have discovered a 'South African variant', 'UK variants' or a 'Brazilian variant' and in the usual HIV-causes-AIDS manner they will unquestioningly repeat it with no evidence whatsoever to support these claims. They will go on television and warn about the dangers of 'new variants' while doing nothing more than repeating what they have been told to be true and knowing that any deviation from that would be career suicide. Big-time insiders will know it's a hoax, but much of the medical community is clueless about the way they are being played and themselves play the public without even being aware they are doing so. What an interesting 'coincidence' that AstraZeneca and Oxford University were conducting 'Covid vaccine trials' in the three countries – the UK, South Africa and Brazil – where the first three 'variants' were claimed to have 'broken out'.

## **Here's your 'virus' – it's a unicorn**

Dr Andrew Kaufman presented a brilliant analysis describing how the 'virus' was imagined into fake existence when he dissected an article published by *Nature* and written by 19 authors detailing *alleged* 'sequencing of a complete viral genome' of the 'new SARS-CoV-2 virus'. This computer-modelled *in silico* genome was used as a template for all subsequent genome sequencing experiments that resulted in the so-called variants which he said now number more than 6,000. The fake genome was constructed from more than 56 million individual short strands of RNA. Those little pieces were assembled into longer pieces by finding areas of overlapping sequences. The computer programs created over two million possible combinations from which the authors simply chose the longest one. They then compared this to a 'bat virus' and the computer 'alignment' rearranged the sequence and filled in the gaps! They called this computer-generated abomination the 'complete genome'. Dr Tom Cowan, a fellow medical author and collaborator with Kaufman, said such computer-generation constitutes scientific fraud and he makes this superb analogy:

Here is an equivalency: A group of researchers claim to have found a unicorn because they found a piece of a hoof, a hair from a tail, and a snippet of a horn. They then add that information into a computer and program it to re-create the unicorn, and they then claim this computer re-creation is the real unicorn. Of course, they had never actually seen a unicorn so could not possibly have examined its genetic makeup to compare their samples with the actual unicorn's hair, hooves and horn.

The researchers claim they decided which is the real genome of SARS-CoV-2 by 'consensus', sort of like a vote. Again, different computer programs will come up with different versions of the imaginary 'unicorn', so they come together as a group and decide which is the real imaginary unicorn.

This is how the 'virus' that has transformed the world was brought into fraudulent 'existence'. Extraordinary, yes, but as the Nazis said the bigger the lie the more will believe it. Cowan, however, wasn't finished and he went on to identify what he called the real blockbuster in the paper. He quotes this section from a paper written

by virologists and published by the CDC and then explains what it means:

Therefore, we examined the capacity of SARS-CoV-2 to infect and replicate in several common primate and human cell lines, including human adenocarcinoma cells (A549), human liver cells (HUH 7.0), and human embryonic kidney cells (HEK-293T). In addition to Vero E6 and Vero CCL81 cells. ... Each cell line was inoculated at high multiplicity of infection and examined 24h post-infection.

No CPE was observed in any of the cell lines except in Vero cells, which grew to greater than 10 to the 7th power at 24 h post-infection. In contrast, HUH 7.0 and 293T showed only modest viral replication, and A549 cells were incompatible with SARS CoV-2 infection.

Cowan explains that when virologists attempt to prove infection they have three possible 'hosts' or models on which they can test. The first was humans. Exposure to humans was generally not done for ethical reasons and has never been done with SARS-CoV-2 or any coronavirus. The second possible host was animals. Cowan said that forgetting for a moment that they never actually use purified virus when exposing animals they do use solutions that they *claim* contain the virus. Exposure to animals has been done with SARS-CoV-2 in an experiment involving mice and this is what they found: *None of the wild (normal) mice got sick.* In a group of genetically-modified mice, a statistically insignificant number lost weight and had slightly bristled fur, but they experienced nothing like the illness called 'Covid-19'. Cowan said the third method – the one they mostly rely on – is to inoculate solutions they *say* contain the virus onto a variety of tissue cultures. This process had never been shown to kill tissue *unless* the sample material was starved of nutrients and poisoned as *part of the process*. Yes, incredibly, in tissue experiments designed to show the 'virus' is responsible for killing the tissue they starve the tissue of nutrients and add toxic drugs including antibiotics and they do not have control studies to see if it's the starvation and poisoning that is degrading the tissue rather than the 'virus' they allege to be in there somewhere. You want me to pinch you? Yep, I understand. Tom Cowan said this about the whole nonsensical farce as he explains what that quote from the CDC paper really means:

The shocking thing about the above quote is that using their own methods, the virologists found that solutions containing SARS-CoV-2 – even in high amounts – were NOT, I repeat NOT, infective to any of the three human tissue cultures they tested. In plain English, this means they proved, on their terms, that this ‘new coronavirus’ is not infectious to human beings. It is ONLY infective to monkey kidney cells, and only then when you add two potent drugs (gentamicin and amphotericin), known to be toxic to kidneys, to the mix.

My friends, read this again and again. These virologists, published by the CDC, performed a clear proof, on their terms, showing that the SARS-CoV-2 virus is harmless to human beings. That is the only possible conclusion, but, unfortunately, this result is not even mentioned in their conclusion. They simply say they can provide virus stocks cultured only on monkey Vero cells, thanks for coming.

Cowan concluded: ‘If people really understood how this “science” was done, I would hope they would storm the gates and demand honesty, transparency and truth.’ Dr Michael Yeadon, former Vice President and Chief Scientific Adviser at drug giant Pfizer has been a vocal critic of the ‘Covid vaccine’ and its potential for multiple harm. He said in an interview in April, 2021, that ‘not one [vaccine] has the virus. He was asked why vaccines normally using a ‘dead’ version of a disease to activate the immune system were not used for ‘Covid’ and instead we had the synthetic methods of the ‘mRNA Covid vaccine’. Yeadon said that to do the former ‘you’d have to have some of [the virus] wouldn’t you?’ He added: ‘No-one’s got any – seriously.’ Yeadon said that surely they couldn’t have fooled the whole world for a year without having a virus, ‘but oddly enough ask around – no one’s got it’. He didn’t know why with all the ‘great labs’ around the world that the virus had not been isolated – ‘Maybe they’ve been too busy running bad PCR tests and vaccines that people don’t need.’ What is today called ‘science’ is not ‘science’ at all. Science is no longer what is, but whatever people can be manipulated to *believe* that it is. Real science has been hijacked by the Cult to dispense and produce the ‘expert scientists’ and contentions that suit the agenda of the Cult. How big-time this has happened with the ‘Covid’ hoax which is entirely based on fake science delivered by fake ‘scientists’ and fake ‘doctors’. The human-caused climate change hoax is also entirely based on fake science delivered by fake ‘scientists’ and fake ‘climate experts’. In both cases real



scientists, climate experts and doctors have their views suppressed and deleted by the Cult-owned science establishment, media and Silicon Valley. This is the 'science' that politicians claim to be 'following' and a common denominator of 'Covid' and climate are Cult psychopaths Bill Gates and his mate Klaus Schwab at the Gates-funded World Economic Forum. But, don't worry, it's all just a coincidence and absolutely nothing to worry about. Zzzzzzzzz.

## **What is a 'virus' REALLY?**

Dr Tom Cowan is one of many contesting the very existence of viruses let alone that they cause disease. This is understandable when there is no scientific evidence for a disease-causing 'virus'. German virologist Dr Stefan Lanka won a landmark case in 2017 in the German Supreme Court over his contention that there is no such thing as a measles virus. He had offered a big prize for anyone who could prove there is and Lanka won his case when someone sought to claim the money. There is currently a prize of more than 225,000 euros on offer from an Isolate Truth Fund for anyone who can prove the isolation of SARS-CoV-2 and its genetic substance. Lanka wrote in an article headed 'The Misconception Called Virus' that scientists think a 'virus' is causing tissue to become diseased and degraded when in fact it is the *processes they are using* which do that – not a 'virus'. Lanka has done an important job in making this point clear as Cowan did in his analysis of the CDC paper. Lanka says that all claims about viruses as disease-causing pathogens are wrong and based on 'easily recognisable, understandable and verifiable misinterpretations.' Scientists believed they were working with 'viruses' in their laboratories when they were really working with 'typical particles of specific dying tissues or cells ...' Lanka said that the tissue decaying process claimed to be caused by a 'virus' still happens when no alleged 'virus' is involved. It's the *process* that does the damage and not a 'virus'. The genetic sample is deprived of nutrients, removed from its energy supply through removal from the body and then doused in toxic antibiotics to remove any bacteria. He confirms again that establishment scientists do not (pinch me)

conduct control experiments to see if this is the case and if they did they would see the claims that 'viruses' are doing the damage is nonsense. He adds that during the measles 'virus' court case he commissioned an independent laboratory to perform just such a control experiment and the result was that the tissues and cells died in the exact same way as with alleged 'infected' material. This is supported by a gathering number of scientists, doctors and researchers who reject what is called 'germ theory' or the belief in the body being infected by contagious sources emitted by other people. Researchers Dawn Lester and David Parker take the same stance in their highly-detailed and sourced book *What Really Makes You Ill – Why everything you thought you knew about disease is wrong* which was recommended to me by a number of medical professionals genuinely seeking the truth. Lester and Parker say there is no provable scientific evidence to show that a 'virus' can be transmitted between people or people and animals or animals and people:

The definition also claims that viruses are the cause of many diseases, as if this has been definitively proven. But this is not the case; there is no original scientific evidence that definitively demonstrates that any virus is the cause of any disease. The burden of proof for any theory lies with those who proposed it; but none of the existing documents provides 'proof' that supports the claim that 'viruses' are pathogens.

Dr Tom Cowan employs one of his clever analogies to describe the process by which a 'virus' is named as the culprit for a disease when what is called a 'virus' is only material released by cells detoxing themselves from infiltration by chemical or radiation poisoning. The tidal wave of technologically-generated radiation in the 'smart' modern world plus all the toxic food and drink are causing this to happen more than ever. Deluded 'scientists' misread this as a gathering impact of what they wrongly label 'viruses'.

### **Paper can infect houses**

Cowan said in an article for [davidicke.com](http://davidicke.com) – with his tongue only mildly in his cheek – that he believed he had made a tremendous

discovery that may revolutionise science. He had discovered that small bits of paper are alive, 'well alive-ish', can 'infect' houses, and then reproduce themselves inside the house. The result was that this explosion of growth in the paper inside the house causes the house to explode, blowing it to smithereens. His evidence for this new theory is that in the past months he had carefully examined many of the houses in his neighbourhood and found almost no scraps of paper on the lawns and surrounds of the house. There was an occasional stray label, but nothing more. Then he would return to these same houses a week or so later and with a few, not all of them, particularly the old and decrepit ones, he found to his shock and surprise they were littered with stray bits of paper. He knew then that the paper had infected these houses, made copies of itself, and blew up the house. A young boy on a bicycle at one of the sites told him he had seen a demolition crew using dynamite to explode the house the previous week, but Cowan dismissed this as the idle thoughts of silly boys because 'I was on to something big'. He was on to how 'scientists' mistake genetic material in the detoxifying process for something they call a 'virus'. Cowan said of his house and paper story:

If this sounds crazy to you, it's because it should. This scenario is obviously nuts. But consider this admittedly embellished, for effect, current viral theory that all scientists, medical doctors and virologists currently believe.

He takes the example of the 'novel SARS-Cov2' virus to prove the point. First they take someone with an undefined illness called 'Covid-19' and don't even attempt to find any virus in their sputum. Never mind the scientists still describe how this 'virus', which they have not located attaches to a cell receptor, injects its genetic material, in 'Covid's' case, RNA, into the cell. The RNA once inserted exploits the cell to reproduce itself and makes 'thousands, nay millions, of copies of itself ... Then it emerges victorious to claim its next victim':

If you were to look in the scientific literature for proof, actual scientific proof, that uniform SARS-CoV2 viruses have been properly isolated from the sputum of a sick person, that actual spike proteins could be seen protruding from the virus (which has not been found), you would find that such evidence doesn't exist.

If you go looking in the published scientific literature for actual pictures, proof, that these spike proteins or any viral proteins are ever attached to any receptor embedded in any cell membrane, you would also find that no such evidence exists. If you were to look for a video or documented evidence of the intact virus injecting its genetic material into the body of the cell, reproducing itself and then emerging victorious by budding off the cell membrane, you would find that no such evidence exists.

The closest thing you would find is electron micrograph pictures of cellular particles, possibly attached to cell debris, both of which to be seen were stained by heavy metals, a process that completely distorts their architecture within the living organism. This is like finding bits of paper stuck to the blown-up bricks, thereby proving the paper emerged by taking pieces of the bricks on its way out.

## **The Enders baloney**

Cowan describes the 'Covid' story as being just as make-believe as his paper story and he charts back this fantasy to a Nobel Prize winner called John Enders (1897-1985), an American biomedical scientist who has been dubbed 'The Father of Modern Vaccines'. Enders is claimed to have 'discovered' the process of the viral culture which 'proved' that a 'virus' caused measles. Cowan explains how Enders did this 'by using the EXACT same procedure that has been followed by every virologist to find and characterize every new virus since 1954'. Enders took throat swabs from children with measles and immersed them in 2ml of milk. Penicillin (100u/ml) and the antibiotic streptomycin (50,g/ml) were added and the whole mix was centrifuged – rotated at high speed to separate large cellular debris from small particles and molecules as with milk and cream, for example. Cowan says that if the aim is to find little particles of genetic material ('viruses') in the snot from children with measles it would seem that the last thing you would do is mix the snot with other material – milk –that also has genetic material. 'How are you ever going to know whether whatever you found came from the snot or the milk?' He points out that streptomycin is a 'nephrotoxic' or poisonous-to-the-kidney drug. You will see the relevance of that

shortly. Cowan says that it gets worse, much worse, when Enders describes the culture medium upon which the virus 'grows': 'The culture medium consisted of bovine amniotic fluid (90%), beef embryo extract (5%), horse serum (5%), antibiotics and phenol red as an indicator of cell metabolism.' Cowan asks incredulously: 'Did he just say that the culture medium also contained fluids and tissues that are themselves rich sources of genetic material?' The genetic cocktail, or 'medium', is inoculated onto tissue and cells from rhesus monkey *kidney* tissue. This is where the importance of streptomycin comes in and currently-used antimicrobials and other drugs that are *poisonous to kidneys* and used in ALL modern viral cultures (e.g. gentamicin, streptomycin, and amphotericin). Cowan asks: 'How are you ever going to know from this witch's brew where any genetic material comes from as we now have five different sources of rich genetic material in our mix?' Remember, he says, that all genetic material, whether from monkey kidney tissues, bovine serum, milk, etc., is made from the exact same components. The same central question returns: 'How are you possibly going to know that it was the virus that killed the kidney tissue and not the toxic antibiotic and starvation rations on which you are growing the tissue?' John Enders answered the question himself – *you can't*:

A second agent was obtained from an uninoculated culture of monkey kidney cells. The cytopathic changes [death of the cells] it induced in the unstained preparations could not be distinguished with confidence from the viruses isolated from measles.

The death of the cells ('cytopathic changes') happened in exactly the same manner, whether they inoculated the kidney tissue with the measles snot or not, Cowan says. 'This is evidence that the destruction of the tissue, the very proof of viral causation of illness, was not caused by anything in the snot because they saw the same destructive effect when the snot was not even used ... the cytopathic, i.e., cell-killing, changes come from the process of the culture itself, not from any virus in any snot, period.' Enders quotes in his 1957 paper a virologist called Ruckle as reporting similar findings 'and in addition has isolated an agent from monkey kidney tissue that is so

far indistinguishable from human measles virus'. In other words, Cowan says, these particles called 'measles viruses' are simply and clearly breakdown products of the starved and poisoned tissue. For measles 'virus' see all 'viruses' including the so-called 'Covid virus'. Enders, the 'Father of Modern Vaccines', also said:

There is a potential risk in employing cultures of primate cells for the production of vaccines composed of attenuated virus, since the presence of other agents possibly latent in primate tissues cannot be definitely excluded by any known method.

Cowan further quotes from a paper published in the journal *Viruses* in May, 2020, while the 'Covid pandemic' was well underway in the media if not in reality. 'EVs' here refers to particles of genetic debris from our own tissues, such as exosomes of which more in a moment: 'The remarkable resemblance between EVs and viruses has caused quite a few problems in the studies focused on the analysis of EVs released during viral infections.' Later the paper adds that to date a reliable method that can actually guarantee a complete separation (of EVs from viruses) DOES NOT EXIST. This was published at a time when a fairy tale 'virus' was claimed in total certainty to be causing a fairy tale 'viral disease' called 'Covid-19' – a fairy tale that was already well on the way to transforming human society in the image that the Cult has worked to achieve for so long. Cowan concludes his article:

To summarize, there is no scientific evidence that pathogenic viruses exist. What we think of as 'viruses' are simply the normal breakdown products of dead and dying tissues and cells. When we are well, we make fewer of these particles; when we are starved, poisoned, suffocated by wearing masks, or afraid, we make more.

There is no engineered virus circulating and making people sick. People in laboratories all over the world are making genetically modified products to make people sick. These are called vaccines. There is no virome, no 'ecosystem' of viruses, viruses are not 8%, 50% or 100 % of our genetic material. These are all simply erroneous ideas based on the misconception called a virus.

## **What is 'Covid'? Load of bollocks**

The background described here by Cowan and Lanka was emphasised in the first video presentation that I saw by Dr Andrew Kaufman when he asked whether the 'Covid virus' was in truth a natural defence mechanism of the body called 'exosomes'. These are released by cells when in states of toxicity – see the same themes returning over and over. They are released ever more profusely as chemical and radiation toxicity increases and think of the potential effect therefore of 5G alone as its destructive frequencies infest the human energetic information field with a gathering pace (5G went online in Wuhan in 2019 as the 'virus' emerged). I'll have more about this later. Exosomes transmit a warning to the rest of the body that 'Houston, we have a problem'. Kaufman presented images of exosomes and compared them with 'Covid' under an electron microscope and the similarity was remarkable. They both attach to the same cell receptors (*claimed* in the case of 'Covid'), contain the same genetic material in the form of RNA or ribonucleic acid, and both are found in 'viral cell cultures' with damaged or dying cells. James Hildreth MD, President and Chief Executive Officer of the Meharry Medical College at Johns Hopkins, said: 'The virus is fully an exosome in every sense of the word.' Kaufman's conclusion was that there is no 'virus': 'This entire pandemic is a completely manufactured crisis ... there is no evidence of anyone dying from [this] illness.' Dr Tom Cowan and Sally Fallon Morell, authors of *The Contagion Myth*, published a statement with Dr Kaufman in February, 2021, explaining why the 'virus' does not exist and you can read it that in full in the Appendix.

'Virus' theory can be traced to the 'cell theory' in 1858 of German physician Rudolf Virchow (1821-1920) who contended that disease originates from a single cell infiltrated by a 'virus'. Dr Stefan Lanka said that findings and insights with respect to the structure, function and central importance of tissues in the creation of life, which were already known in 1858, comprehensively refute the cell theory. Virchow ignored them. We have seen the part later played by John Enders in the 1950s and Lanka notes that infection theories were only established as a global dogma through the policies and

eugenics of the Third Reich in Nazi Germany (creation of the same Sabbatian cult behind the 'Covid' hoax). Lanka said: 'Before 1933, scientists dared to contradict this theory; after 1933, these critical scientists were silenced'. Dr Tom Cowan's view is that ill-health is caused by too much of something, too little of something, or toxification from chemicals and radiation – not contagion. We must also highlight as a major source of the 'virus' theology a man still called the 'Father of Modern Virology' – Thomas Milton Rivers (1888-1962). There is no way given the Cult's long game policy that it was a coincidence for the 'Father of Modern Virology' to be director of the Rockefeller Institute for Medical Research from 1937 to 1956 when he is credited with making the Rockefeller Institute a leader in 'viral research'. Cult Rockefeller were the force behind the creation of Big Pharma 'medicine', established the World Health Organisation in 1948, and have long and close associations with the Gates family that now runs the WHO during the pandemic hoax through mega-rich Cult gofer and psychopath Bill Gates.

Only a Renegade Mind can see through all this bullshit by asking the questions that need to be answered, not taking 'no' or prevarication for an answer, and certainly not hiding from the truth in fear of speaking it. Renegade Minds have always changed the world for the better and they will change this one no matter how bleak it may currently appear to be.



## CHAPTER SIX

### **Sequence of deceit**

*If you tell the truth, you don't have to remember anything*  
Mark Twain

**A**gainst the background that I have laid out this far the sequence that took us from an invented 'virus' in Cult-owned China in late 2019 to the fascist transformation of human society can be seen and understood in a whole new context.

We were told that a deadly disease had broken out in Wuhan and the world media began its campaign (coordinated by behavioural psychologists as we shall see) to terrify the population into unquestioning compliance. We were shown images of Chinese people collapsing in the street which never happened in the West with what was supposed to be the same condition. In the earliest days when alleged cases and deaths were few the fear register was hysterical in many areas of the media and this would expand into the common media narrative across the world. The real story was rather different, but we were never told that. The Chinese government, one of the Cult's biggest centres of global operation, said they had discovered a new illness with flu-like and pneumonia-type symptoms in a city with such toxic air that it is overwhelmed with flu-like symptoms, pneumonia and respiratory disease. Chinese scientists said it was a new – 'novel' – coronavirus which they called Sars-Cov-2 and that it caused a disease they labelled 'Covid-19'. There was no evidence for this and the 'virus' has never to this day been isolated, purified and its genetic code established from that. It

was from the beginning a computer-generated fiction. Stories of Chinese whistleblowers saying the number of deaths was being suppressed or that the 'new disease' was related to the Wuhan bio-lab misdirected mainstream and alternative media into cul-de-sacs to obscure the real truth – there was no 'virus'.

Chinese scientists took genetic material from the lung fluid of just a few people and said they had found a 'new' disease when this material had a wide range of content. There was no evidence for a 'virus' for the very reasons explained in the last two chapters. The 'virus' has never been shown to (a) exist and (b) cause any disease. People were diagnosed on symptoms that are so widespread in Wuhan and polluted China and with a PCR test that can't detect infectious disease. On this farce the whole global scam was sold to the rest of the world which would also diagnose respiratory disease as 'Covid-19' from symptoms alone or with a PCR test not testing for a 'virus'. Flu miraculously disappeared *worldwide* in 2020 and into 2021 as it was redesignated 'Covid-19'. It was really the same old flu with its 'flu-like' symptoms attributed to 'flu-like' 'Covid-19'. At the same time with very few exceptions the Chinese response of draconian lockdown and fascism was the chosen weapon to respond across the West as recommended by the Cult-owned Tedros at the Cult-owned World Health Organization run by the Cult-owned Gates. All was going according to plan. Chinese scientists – everything in China is controlled by the Cult-owned government – compared their contaminated RNA lung-fluid material with other RNA sequences and said it appeared to be just under 80 percent identical to the SARS-CoV-1 'virus' claimed to be the cause of the SARS (severe acute respiratory syndrome) 'outbreak' in 2003. They decreed that because of this the 'new virus' had to be related and they called it SARS-CoV-2. There are some serious problems with this assumption and *assumption* was all it was. Most 'factual' science turns out to be assumptions repeated into everyone-knows-that. A match of under 80-percent is meaningless. Dr Kaufman makes the point that there's a 96 percent genetic correlation between humans and chimpanzees, but 'no one would say our genetic material is part

of the chimpanzee family'. Yet the Chinese authorities were claiming that a much lower percentage, less than 80 percent, proved the existence of a new 'coronavirus'. For goodness sake human DNA is 60 percent similar to a *banana*.

## **You are feeling sleepy**

The entire 'Covid' hoax is a global Psyop, a psychological operation to program the human mind into believing and fearing a complete fantasy. A crucial aspect of this was what *appeared* to happen in Italy. It was all very well streaming out daily images of an alleged catastrophe in Wuhan, but to the Western mind it was still on the other side of the world in a very different culture and setting. A reaction of 'this could happen to me and my family' was still nothing like as intense enough for the mind-doctors. The Cult needed a Western example to push people over that edge and it chose Italy, one of its major global locations going back to the Roman Empire. An Italian 'Covid' crisis was manufactured in a particular area called Lombardy which just happens to be notorious for its toxic air and therefore respiratory disease. Wuhan, China, *déjà vu*. An hysterical media told horror stories of Italians dying from 'Covid' in their droves and how Lombardy hospitals were being overrun by a tidal wave of desperately ill people needing treatment after being struck down by the 'deadly virus'. Here was the psychological turning point the Cult had planned. Wow, if this is happening in Italy, the Western mind concluded, this indeed could happen to me and my family. Another point is that Italian authorities responded by following the Chinese blueprint so vehemently recommended by the Cult-owned World Health Organization. They imposed fascistic lockdowns on the whole country viciously policed with the help of surveillance drones sweeping through the streets seeking out anyone who escaped from mass house arrest. Livelihoods were destroyed and psychology unravelled in the way we have witnessed since in all lockdown countries. Crucial to the plan was that Italy responded in this way to set the precedent of suspending freedom and imposing fascism in a 'Western liberal democracy'. I emphasised in an

animated video explanation on [davidicke.com](http://davidicke.com) posted in the summer of 2020 how important it was to the Cult to expand the Chinese lockdown model across the West. Without this, and the bare-faced lie that non-symptomatic people could still transmit a 'disease' they didn't have, there was no way locking down the whole population, sick and not sick, could be pulled off. At just the right time and with no evidence Cult operatives and gofers claimed that people without symptoms could pass on the 'disease'. In the name of protecting the 'vulnerable' like elderly people, who lockdowns would kill by the tens of thousands, we had for the first time healthy people told to isolate as well as the sick. The great majority of people who tested positive had no symptoms because there was nothing wrong with them. It was just a trick made possible by a test not testing for the 'virus'.

Months after my animated video the Gates-funded Professor Neil Ferguson at the Gates-funded Imperial College confirmed that I was right. He didn't say it in those terms, naturally, but he did say it. Ferguson will enter the story shortly for his outrageously crazy 'computer models' that led to Britain, the United States and many other countries following the Chinese and now Italian methods of response. Put another way, following the Cult script. Ferguson said that SAGE, the UK government's scientific advisory group which has controlled 'Covid' policy from the start, wanted to follow the Chinese lockdown model (while they all continued to work and be paid), but they wondered if they could possibly, in Ferguson's words, 'get away with it in Europe'. 'Get away with it'? Who the hell do these moronic, arrogant people think they are? This appalling man Ferguson said that once Italy went into national lockdown they realised they, too, could mimic China:

It's a communist one-party state, we said. We couldn't get away with it in Europe, we thought ... and then Italy did it. And we realised we could. Behind this garbage from Ferguson is a simple fact: Doing the same as China in every country was the plan from the start and Ferguson's 'models' would play a central role in achieving that. It's just a coincidence, of course, and absolutely nothing to worry your little head about.

## **Oops, sorry, our mistake**

Once the Italian segment of the Psyop had done the job it was designed to do a very different story emerged. Italian authorities revealed that 99 percent of those who had 'died from Covid-19' in Italy had one, two, three, or more 'co-morbidities' or illnesses and health problems that could have ended their life. The US Centers for Disease Control and Prevention (CDC) published a figure of 94 percent for Americans dying of 'Covid' while having other serious medical conditions – on average two to three (some five or six) other potential causes of death. In terms of death from an unproven 'virus' I say it is 100 percent. The other one percent in Italy and six percent in the US would presumably have died from 'Covid's' flu-like symptoms with a range of other possible causes in conjunction with a test not testing for the 'virus'. Fox News reported that even more startling figures had emerged in one US county in which 410 of 422 deaths attributed to 'Covid-19' had other potentially deadly health conditions. The Italian National Health Institute said later that the average age of people dying with a 'Covid-19' diagnosis in Italy was about 81. Ninety percent were over 70 with ten percent over 90. In terms of other reasons to die some 80 percent had two or more chronic diseases with half having three or more including cardiovascular problems, diabetes, respiratory problems and cancer. Why is the phantom 'Covid-19' said to kill overwhelmingly old people and hardly affect the young? Old people continually die of many causes and especially respiratory disease which you can re-diagnose 'Covid-19' while young people die in tiny numbers by comparison and rarely of respiratory disease. Old people 'die of Covid' because they die of other things that can be redesignated 'Covid' and it really is that simple.

## **Flu has flown**

The blueprint was in place. Get your illusory 'cases' from a test not testing for the 'virus' and redesignate other causes of death as 'Covid-19'. You have an instant 'pandemic' from something that is nothing more than a computer-generated fiction. With near-on a

billion people having 'flu-like' symptoms every year the potential was limitless and we can see why flu quickly and apparently miraculously disappeared *worldwide* by being diagnosed 'Covid-19'. The painfully bloody obvious was explained away by the childlike media in headlines like this in the UK '*Independent*': 'Not a single case of flu detected by Public Health England this year as Covid restrictions suppress virus'. I kid you not. The masking, social distancing and house arrest that did not make the 'Covid virus' disappear somehow did so with the 'flu virus'. Even worse the article, by a bloke called Samuel Lovett, suggested that maybe the masking, sanitising and other 'Covid' measures should continue to keep the flu away. With a ridiculousness that disturbs your breathing (it's 'Covid-19') the said Lovett wrote: 'With widespread social distancing and mask-wearing measures in place throughout the UK, the usual routes of transmission for influenza have been blocked.' He had absolutely no evidence to support that statement, but look at the consequences of him acknowledging the obvious. With flu not disappearing at all and only being relabelled 'Covid-19' he would have to contemplate that 'Covid' was a hoax on a scale that is hard to imagine. You need guts and commitment to truth to even go there and that's clearly something Samuel Lovett does not have in abundance. He would never have got it through the editors anyway.

Tens of thousands die in the United States alone every winter from flu including many with pneumonia complications. CDC figures record *45 million* Americans diagnosed with flu in 2017-2018 of which 61,000 died and some reports claim 80,000. Where was the same hysteria then that we have seen with 'Covid-19'? Some 250,000 Americans are admitted to hospital with pneumonia every year with about 50,000 cases proving fatal. About 65 million suffer respiratory disease every year and three million deaths makes this the third biggest cause of death worldwide. You only have to redesignate a portion of all these people 'Covid-19' and you have an instant global pandemic or the *appearance* of one. Why would doctors do this? They are told to do this and all but a few dare not refuse those who must be obeyed. Doctors in general are not researching their own

knowledge and instead take it direct and unquestioned from the authorities that own them and their careers. The authorities say they must now diagnose these symptoms 'Covid-19' and not flu, or whatever, and they do it. Dark suits say put 'Covid-19' on death certificates no matter what the cause of death and the doctors do it. Renegade Minds don't fall for the illusion that doctors and medical staff are all highly-intelligent, highly-principled, seekers of medical truth. *Some are*, but not the majority. They are repeaters, gofers, and yes sir, no sir, purveyors of what the system demands they purvey. The 'Covid' con is not merely confined to diseases of the lungs. Instructions to doctors to put 'Covid-19' on death certificates for anyone dying of *anything* within 28 days (or much more) of a positive test not testing for the 'virus' opened the floodgates. The term dying *with* 'Covid' and not *of* 'Covid' was coined to cover the truth. Whether it was a *with* or an *of* they were all added to the death numbers attributed to the 'deadly virus' compiled by national governments and globally by the Gates-funded Johns Hopkins operation in the United States that was so involved in those 'pandemic' simulations. Fraudulent deaths were added to the ever-growing list of fraudulent 'cases' from false positives from a false test. No wonder Professor Walter Ricciardi, scientific advisor to the Italian minister of health, said after the Lombardy hysteria had done its job that 'Covid' death rates were due to Italy having the second oldest population in the world and to *how hospitals record deaths*:

The way in which we code deaths in our country is very generous in the sense that all the people who die in hospitals with the coronavirus are deemed to be dying of the coronavirus. On re-evaluation by the National Institute of Health, only 12 per cent of death certificates have shown a direct causality from coronavirus, while 88 per cent of patients who have died have at least one pre-morbidity – many had two or three.

This is extraordinary enough when you consider the propaganda campaign to use Italy to terrify the world, but how can they even say twelve percent were genuine when the 'virus' has not been shown to exist, its 'code' is a computer program, and diagnosis comes from a test not testing for it? As in China, and soon the world, 'Covid-19' in

Italy was a redesignation of diagnosis. Lies and corruption were to become the real 'pandemic' fuelled by a pathetically-compliant medical system taking its orders from the tiny few at the top of their national hierarchy who answered to the World Health Organization which answers to Gates and the Cult. Doctors were told – ordered – to diagnose a particular set of symptoms 'Covid-19' and put that on the death certificate for any cause of death if the patient had tested positive with a test not testing for the virus or had 'Covid' symptoms like the flu. The United States even introduced big financial incentives to manipulate the figures with hospitals receiving £4,600 from the Medicare system for diagnosing someone with regular pneumonia, \$13,000 if they made the diagnosis from the same symptoms 'Covid-19' pneumonia, and \$39,000 if they put a 'Covid' diagnosed patient on a ventilator that would almost certainly kill them. A few – painfully and pathetically few – medical whistleblowers revealed (before Cult-owned YouTube deleted their videos) that they had been instructed to 'let the patient crash' and put them straight on a ventilator instead of going through a series of far less intrusive and dangerous methods as they would have done before the pandemic hoax began and the financial incentives kicked in. We are talking cold-blooded murder given that ventilators are so damaging to respiratory systems they are usually the last step before heaven awaits. Renegade Minds never fall for the belief that people in white coats are all angels of mercy and cannot be full-on psychopaths. I have explained in detail in *The Answer* how what I am describing here played out across the world coordinated by the World Health Organization through the medical hierarchies in almost every country.

### **Medical scientist calls it**

Information about the non-existence of the 'virus' began to emerge for me in late March, 2020, and mushroomed after that. I was sent an email by Sir Julian Rose, a writer, researcher, and organic farming promotor, from a medical scientist friend of his in the United States. Even at that early stage in March the scientist was able to explain



how the 'Covid' hoax was being manipulated. He said there were no reliable tests for a specific 'Covid-19 virus' and nor were there any reliable agencies or media outlets for reporting numbers of actual 'Covid-19' cases. We have seen in the long period since then that he was absolutely right. 'Every action and reaction to Covid-19 is based on totally flawed data and we simply cannot make accurate assessments,' he said. Most people diagnosed with 'Covid-19' were showing nothing more than cold and flu-like symptoms 'because most coronavirus strains *are* nothing more than cold/flu-like symptoms'. We had farcical situations like an 84-year-old German man testing positive for 'Covid-19' and his nursing home ordered to quarantine only for him to be found to have a common cold. The scientist described back then why PCR tests and what he called the 'Mickey Mouse test kits' were useless for what they were claimed to be identifying. 'The idea these kits can isolate a specific virus like Covid-19 is nonsense,' he said. Significantly, he pointed out that 'if you want to create a totally false panic about a totally false pandemic – pick a coronavirus'. This is exactly what the Cult-owned Gates, World Economic Forum and Johns Hopkins University did with their Event 201 'simulation' followed by their real-life simulation called the 'pandemic'. The scientist said that all you had to do was select the sickest of people with respiratory-type diseases in a single location – 'say Wuhan' – and administer PCR tests to them. You can then claim that anyone showing 'viral sequences' similar to a coronavirus 'which will inevitably be quite a few' is suffering from a 'new' disease:

Since you already selected the sickest flu cases a fairly high proportion of your sample will go on to die. You can then say this 'new' virus has a CFR [case fatality rate] higher than the flu and use this to infuse more concern and do more tests which will of course produce more 'cases', which expands the testing, which produces yet more 'cases' and so on and so on. Before long you have your 'pandemic', and all you have done is use a simple test kit trick to convert the worst flu and pneumonia cases into something new that doesn't ACTUALLY EXIST [my emphasis].

He said that you then 'just run the same scam in other countries' and make sure to keep the fear message running high 'so that people

will feel panicky and less able to think critically'. The only problem to overcome was the fact *there is no* actual new deadly pathogen and only regular sick people. This meant that deaths from the 'new deadly pathogen' were going to be way too low for a real new deadly virus pandemic, but he said this could be overcome in the following ways – all of which would go on to happen:

1. You can claim this is just the beginning and more deaths are imminent [you underpin this with fantasy 'computer projections']. Use this as an excuse to quarantine everyone and then claim the quarantine prevented the expected millions of dead.
2. You can [say that people] 'minimizing' the dangers are irresponsible and bully them into not talking about numbers.
3. You can talk crap about made up numbers hoping to blind people with pseudoscience.
4. You can start testing well people (who, of course, will also likely have shreds of coronavirus [RNA] in them) and thus inflate your 'case figures' with 'asymptomatic carriers' (you will of course have to spin that to sound deadly even though any virologist knows the more symptom-less cases you have the less deadly is your pathogen).

The scientist said that if you take these simple steps 'you can have your own entirely manufactured pandemic up and running in weeks'. His analysis made so early in the hoax was brilliantly prophetic of what would actually unfold. Pulling all the information together in these recent chapters we have this is simple 1, 2, 3, of how you can delude virtually the entire human population into believing in a 'virus' that doesn't exist:

- A 'Covid case' is someone who tests positive with a test not testing for the 'virus'.
- A 'Covid death' is someone who dies of *any cause* within 28 days (or much longer) of testing positive with a test not testing for the 'virus'.
- Asymptomatic means there is nothing wrong with you, but they claim you can pass on what you don't have to justify locking

down (quarantining) healthy people in totality.

The foundations of the hoax are that simple. A study involving ten million people in Wuhan, published in November, 2020, demolished the whole lie about those without symptoms passing on the 'virus'. They found '300 asymptomatic cases' and traced their contacts to find that not one of them was detected with the 'virus'.

'Asymptomatic' patients and their contacts were isolated for no less than two weeks and nothing changed. I know it's all crap, but if you are going to claim that those without symptoms can transmit 'the virus' then you must produce evidence for that and they never have. Even World Health Organization official Dr Maria Van Kerkhove, head of the emerging diseases and zoonosis unit, said as early as June, 2020, that she doubted the validity of asymptomatic transmission. She said that 'from the data we have, it still seems to be rare that an asymptomatic person actually transmits onward to a secondary individual' and by 'rare' she meant that she couldn't cite any case of asymptomatic transmission.

### **The Ferguson factor**

The problem for the Cult as it headed into March, 2020, when the script had lockdown due to start, was that despite all the manipulation of the case and death figures they still did not have enough people alleged to have died from 'Covid' to justify mass house arrest. This was overcome in the way the scientist described: 'You can claim this is just the beginning and more deaths are imminent ... Use this as an excuse to quarantine everyone and then claim the quarantine prevented the expected millions of dead.' Enter one Professor Neil Ferguson, the Gates-funded 'epidemiologist' at the Gates-funded Imperial College in London. Ferguson is Britain's Christian Drosten in that he has a dire record of predicting health outcomes, but is still called upon to advise government on the next health outcome when another 'crisis' comes along. This may seem to be a strange and ridiculous thing to do. Why would you keep turning for policy guidance to people who have a history of being

monumentally wrong? Ah, but it makes sense from the Cult point of view. These 'experts' keep on producing predictions that suit the Cult agenda for societal transformation and so it was with Neil Ferguson as he revealed his horrific (and clearly insane) computer model predictions that allowed lockdowns to be imposed in Britain, the United States and many other countries. Ferguson does not have even an A-level in biology and would appear to have no formal training in computer modelling, medicine or epidemiology, according to Derek Winton, an MSc in Computational Intelligence. He wrote an article somewhat aghast at what Ferguson did which included taking no account of respiratory disease 'seasonality' which means it is far worse in the winter months. Who would have thought that respiratory disease could be worse in the winter? Well, certainly not Ferguson.

The massively China-connected Imperial College and its bizarre professor provided the excuse for the long-incubated Chinese model of human control to travel westward at lightning speed. Imperial College confirms on its website that it collaborates with the Chinese Research Institute; publishes more than 600 research papers every year with Chinese research institutions; has 225 Chinese staff; 2,600 Chinese students – the biggest international group; 7,000 former students living in China which is the largest group outside the UK; and was selected for a tour by China's President Xi Jinping during his state visit to the UK in 2015. The college takes major donations from China and describes itself as the UK's number one university collaborator with Chinese research institutions. The China communist/fascist government did not appear phased by the woeful predictions of Ferguson and Imperial when during the lockdown that Ferguson induced the college signed a five-year collaboration deal with China tech giant Huawei that will have Huawei's indoor 5G network equipment installed at the college's West London tech campus along with an 'AI cloud platform'. The deal includes Chinese sponsorship of Imperial's Venture Catalyst entrepreneurship competition. Imperial is an example of the enormous influence the Chinese government has within British and North American

universities and research centres – and further afield. Up to 200 academics from more than a dozen UK universities are being investigated on suspicion of ‘unintentionally’ helping the Chinese government build weapons of mass destruction by ‘transferring world-leading research in advanced military technology such as aircraft, missile designs and cyberweapons’. Similar scandals have broken in the United States, but it’s all a coincidence. Imperial College serves the agenda in many other ways including the promotion of every aspect of the United Nations Agenda 21/2030 (the Great Reset) and produced computer models to show that human-caused ‘climate change’ is happening when in the real world it isn’t. Imperial College is driving the climate agenda as it drives the ‘Covid’ agenda (both Cult hoaxes) while Patrick Vallance, the UK government’s Chief Scientific Adviser on ‘Covid’, was named Chief Scientific Adviser to the UN ‘climate change’ conference known as COP26 hosted by the government in Glasgow, Scotland. ‘Covid’ and ‘climate’ are fundamentally connected.

## **Professor Woeful**

From Imperial’s bosom came Neil Ferguson still advising government despite his previous disasters and it was announced early on that he and other key people like UK Chief Medical Adviser Chris Whitty had caught the ‘virus’ as the propaganda story was being sold. Somehow they managed to survive and we had Prime Minister Boris Johnson admitted to hospital with what was said to be a severe version of the ‘virus’ in this same period. His whole policy and demeanour changed when he returned to Downing Street. It’s a small world with these government advisors – especially in their communal connections to Gates – and Ferguson had partnered with Whitty to write a paper called ‘Infectious disease: Tough choices to reduce Ebola transmission’ which involved another scare-story that didn’t happen. Ferguson’s ‘models’ predicted that up to 150,000 could die from ‘mad cow disease’, or BSE, and its version in sheep if it was transmitted to humans. BSE was not transmitted and instead triggered by an organophosphate pesticide used to treat a pest on

cows. Fewer than 200 deaths followed from the human form. Models by Ferguson and his fellow incompetents led to the unnecessary culling of millions of pigs, cattle and sheep in the foot and mouth outbreak in 2001 which destroyed the lives and livelihoods of farmers and their families who had often spent decades building their herds and flocks. Vast numbers of these animals did not have foot and mouth and had no contact with the infection. Another 'expert' behind the cull was Professor Roy Anderson, a computer modeller at Imperial College specialising in the epidemiology of *human*, not animal, disease. Anderson has served on the Bill and Melinda Gates Grand Challenges in Global Health advisory board and chairs another Gates-funded organisation. Gates is everywhere.

In a precursor to the 'Covid' script Ferguson backed closing schools 'for prolonged periods' over the swine flu 'pandemic' in 2009 and said it would affect a third of the world population if it continued to spread at the speed he claimed to be happening. His mates at Imperial College said much the same and a news report said: 'One of the authors, the epidemiologist and disease modeller Neil Ferguson, who sits on the World Health Organisation's emergency committee for the outbreak, said the virus had "full pandemic potential".' Professor Liam Donaldson, the Chris Whitty of his day as Chief Medical Officer, said the worst case could see 30 percent of the British people infected by swine flu with 65,000 dying. Ferguson and Donaldson were indeed proved correct when at the end of the year the number of deaths attributed to swine flu was 392. The term 'expert' is rather liberally applied unfortunately, not least to complete idiots. Swine flu 'projections' were great for GlaxoSmithKline (GSK) as millions rolled in for its Pandemrix influenza vaccine which led to brain damage with children most affected. The British government (taxpayers) paid out more than £60 million in compensation after GSK was given immunity from prosecution. Yet another 'Covid' déjà vu. Swine flu was supposed to have broken out in Mexico, but Dr Wolfgang Wodarg, a German doctor, former member of parliament and critic of the 'Covid' hoax, observed 'the spread of swine flu' in Mexico City at the time. He

said: 'What we experienced in Mexico City was a very mild flu which did not kill more than usual – which killed even fewer people than usual.' Hying the fear against all the facts is not unique to 'Covid' and has happened many times before. Ferguson is reported to have over-estimated the projected death toll of bird flu (H5N1) by some three million-fold, but bird flu vaccine makers again made a killing from the scare. This is some of the background to the Neil Ferguson who produced the perfectly-timed computer models in early 2020 predicting that half a million people would die in Britain without draconian lockdown and 2.2 million in the United States. Politicians panicked, people panicked, and lockdowns of alleged short duration were instigated to 'flatten the curve' of cases gleaned from a test not testing for the 'virus'. I said at the time that the public could forget the 'short duration' bit. This was an agenda to destroy the livelihoods of the population and force them into mass control through dependency and there was going to be nothing 'short' about it. American researcher Daniel Horowitz described the consequences of the 'models' spewed out by Gates-funded Ferguson and Imperial College:

What led our government and the governments of many other countries into panic was a single Imperial College of UK study, funded by global warming activists, that predicted 2.2 million deaths if we didn't lock down the country. In addition, the reported 8-9% death rate in Italy scared us into thinking there was some other mutation of this virus that they got, which might have come here.

Together with the fact that we were finally testing and had the ability to actually report new cases, we thought we were headed for a death spiral. But again ... we can't flatten a curve if we don't know when the curve started.

How about it *never* started?

## **Giving them what they want**

An investigation by German news outlet *Welt Am Sonntag* (*World on Sunday*) revealed how in March, 2020, the German government gathered together 'leading scientists from several research institutes and universities' and 'together, they were to produce a [modelling]

paper that would serve as legitimization for further tough political measures'. The Cult agenda was justified by computer modelling not based on evidence or reality; it was specifically constructed to justify the Cult demand for lockdowns all over the world to destroy the independent livelihoods of the global population. All these modellers and everyone responsible for the 'Covid' hoax have a date with a trial like those in Nuremberg after World War Two when Nazis faced the consequences of their war crimes. These corrupt-beyond-belief 'modellers' wrote the paper according to government instructions and it said that that if lockdown measures were lifted then up to one million Germans would die from 'Covid-19' adding that some would die 'agonizingly at home, gasping for breath' unable to be treated by hospitals that couldn't cope. All lies. No matter – it gave the Cult all that it wanted. What did long-time government 'modeller' Neil Ferguson say? If the UK and the United States didn't lockdown half a million would die in Britain and 2.2 million Americans. Anyone see a theme here? 'Modellers' are such a crucial part of the lockdown strategy that we should look into their background and follow the money. Researcher Rosemary Frei produced an excellent article headlined 'The Modelling-paper Mafiosi'. She highlights a guy called John Edmunds, a British epidemiologist, and professor in the Faculty of Epidemiology and Population Health at the London School of Hygiene & Tropical Medicine. He studied at Imperial College. Edmunds is a member of government 'Covid' advisory bodies which have been dictating policy, the New and Emerging Respiratory Virus Threats Advisory Group (NERVTAG) and the Scientific Advisory Group for Emergencies (SAGE).

Ferguson, another member of NERVTAG and SAGE, led the way with the original 'virus' and Edmunds has followed in the 'variant' stage and especially the so-called UK or Kent variant known as the 'Variant of Concern' (VOC) B.1.1.7. He said in a co-written report for the Centre for Mathematical modelling of Infectious Diseases at the London School of Hygiene and Tropical Medicine, with input from the Centre's 'Covid-19' Working Group, that there was 'a realistic



possibility that VOC B.1.1.7 is associated with an increased risk of death compared to non-VOC viruses'. Fear, fear, fear, get the vaccine, fear, fear, fear, get the vaccine. Rosemary Frei reveals that almost all the paper's authors and members of the modelling centre's 'Covid-19' Working Group receive funding from the Bill and Melinda Gates Foundation and/or the associated Gates-funded Wellcome Trust. The paper was published by e-journal *Medrx* *xiv* which only publishes papers not peer-reviewed and the journal was established by an organisation headed by Facebook's Mark Zuckerberg and his missus. What a small world it is. Frei discovered that Edmunds is on the Scientific Advisory Board of the Coalition for Epidemic Preparedness Innovations (CEPI) which was established by the Bill and Melinda Gates Foundation, Klaus Schwab's Davos World Economic Forum and Big Pharma giant Wellcome. CEPI was 'launched in Davos [in 2017] to develop vaccines to stop future epidemics', according to its website. 'Our mission is to accelerate the development of vaccines against emerging infectious diseases and enable equitable access to these vaccines for people during outbreaks.' What kind people they are. Rosemary Frei reveals that Public Health England (PHE) director Susan Hopkins is an author of her organisation's non-peer-reviewed reports on 'new variants'. Hopkins is a professor of infectious diseases at London's Imperial College which is gifted tens of millions of dollars a year by the Bill and Melinda Gates Foundation. Gates-funded modelling disaster Neil Ferguson also co-authors Public Health England reports and he spoke in December, 2020, about the potential danger of the B.1.1.7. 'UK variant' promoted by Gates-funded modeller John Edmunds. When I come to the 'Covid vaccines' the 'new variants' will be shown for what they are – bollocks.

## **Connections, connections**

All these people and modellers are lockdown-obsessed or, put another way, they demand what the Cult demands. Edmunds said in January, 2021, that to ease lockdowns too soon would be a disaster and they had to 'vaccinate much, much, much more widely than the

elderly'. Rosemary Frei highlights that Edmunds is married to Jeanne Pimenta who is described in a LinkedIn profile as director of epidemiology at GlaxoSmithKline (GSK) and she held shares in the company. Patrick Vallance, co-chair of SAGE and the government's Chief Scientific Adviser, is a former executive of GSK and has a deferred bonus of shares in the company worth £600,000. GSK has serious business connections with Bill Gates and is collaborating with mRNA-'vaccine' company CureVac to make 'vaccines' for the new variants that Edmunds is talking about. GSK is planning a 'Covid vaccine' with drug giant Sanofi. Puppets Prime Minister Boris Johnson announced in the spring of 2021 that up to 60 million vaccine doses were to be made at the GSK facility at Barnard Castle in the English North East. Barnard Castle, with a population of just 6,000, was famously visited in breach of lockdown rules in April, 2020, by Johnson aide Dominic Cummings who said that he drove there 'to test his eyesight' before driving back to London. Cummings would be better advised to test his integrity – not that it would take long. The GSK facility had nothing to do with his visit then although I'm sure Patrick Vallance would have been happy to arrange an introduction and some tea and biscuits. Ruthless psychopath Gates has made yet another fortune from vaccines in collaboration with Big Pharma companies and gushes at the phenomenal profits to be made from vaccines – more than a 20-to-1 return as he told one interviewer. Gates also tweeted in December, 2019, with the foreknowledge of what was coming: 'What's next for our foundation? I'm particularly excited about what the next year could mean for one of the best buys in global health: vaccines.'

Modeller John Edmunds is a big promoter of vaccines as all these people appear to be. He's the dean of the London School of Hygiene & Tropical Medicine's Faculty of Epidemiology and Population Health which is primarily funded by the Bill and Melinda Gates Foundation and the Gates-established and funded GAVI vaccine alliance which is the Gates vehicle to vaccinate the world. The organisation Doctors Without Borders has described GAVI as being 'aimed more at supporting drug-industry desires to promote new

products than at finding the most efficient and sustainable means for fighting the diseases of poverty'. But then that's why the psychopath Gates created it. John Edmunds said in a video that the London School of Hygiene & Tropical Medicine is involved in every aspect of vaccine development including large-scale clinical trials. He contends that mathematical modelling can show that vaccines protect individuals and society. That's on the basis of shit in and shit out, I take it. Edmunds serves on the UK Vaccine Network as does Ferguson and the government's foremost 'Covid' adviser, the grim-faced, dark-eyed Chris Whitty. The Vaccine Network says it works 'to support the government to identify and shortlist targeted investment opportunities for the most promising vaccines and vaccine technologies that will help combat infectious diseases with epidemic potential, and to address structural issues related to the UK's broader vaccine infrastructure'. Ferguson is acting Director of the Imperial College Vaccine Impact Modelling Consortium which has funding from the Bill and Melina Gates Foundation and the Gates-created GAVI 'vaccine alliance'. Anyone wonder why these characters see vaccines as the answer to every problem? Ferguson is wildly enthusiastic in his support for GAVI's campaign to vaccinate children en masse in poor countries. You would expect someone like Gates who has constantly talked about the need to reduce the population to want to fund vaccines to keep more people alive. I'm sure that's why he does it. The John Edmunds London School of Hygiene & Tropical Medicine (LSHTM) has a Vaccines Manufacturing Innovation Centre which develops, tests and commercialises vaccines. Rosemary Frei writes:

The vaccines centre also performs affiliated activities like combating 'vaccine hesitancy'. The latter includes the Vaccine Confidence Project. The project's stated purpose is, among other things, 'to provide analysis and guidance for early response and engagement with the public to ensure sustained confidence in vaccines and immunisation'. The Vaccine Confidence Project's director is LSHTM professor Heidi Larson. For more than a decade she's been researching how to combat vaccine hesitancy.

How the bloody hell can blokes like John Edmunds and Neil Ferguson with those connections and financial ties model 'virus' case

and death projections for the government and especially in a way that gives their paymasters like Gates exactly what they want? It's insane, but this is what you find throughout the world.

### **'Covid' is not dangerous, oops, wait, yes it is**

Only days before Ferguson's nightmare scenario made Jackboot Johnson take Britain into a China-style lockdown to save us from a deadly 'virus' the UK government website gov.uk was reporting something very different to Ferguson on a page of official government guidance for 'high consequence infectious diseases (HCID)'. It said this about 'Covid-19':

*As of 19 March 2020, COVID-19 is no longer considered to be a high consequence infectious diseases (HCID) in the UK [my emphasis].* The 4 nations public health HCID group made an interim recommendation in January 2020 to classify COVID-19 as an HCID. This was based on consideration of the UK HCID criteria about the virus and the disease with information available during the early stages of the outbreak.

Now that more is known about COVID-19, the public health bodies in the UK have reviewed the most up to date information about COVID-19 against the UK HCID criteria. They have determined that several features have now changed; in particular, more information is available about mortality rates (low overall), and there is now greater clinical awareness and a specific and sensitive laboratory test, the availability of which continues to increase. The Advisory Committee on Dangerous Pathogens (ACDP) is also of the opinion that COVID-19 should no longer be classified as an HCID.

Soon after the government had been exposed for downgrading the risk they upgraded it again and everyone was back to singing from the same Cult hymn book. Ferguson and his fellow Gates clones indicated that lockdowns and restrictions would have to continue until a Gates-funded vaccine was developed. Gates said the same because Ferguson and his like were repeating the Gates script which is the Cult script. 'Flatten the curve' became an ongoing nightmare of continuing lockdowns with periods in between of severe restrictions in pursuit of destroying independent incomes and had nothing to do with protecting health about which the Cult gives not a shit. Why wouldn't Ferguson be pushing a vaccine 'solution' when he's owned by vaccine-obsessive Gates who makes a fortune from them and

when Ferguson heads the Vaccine Impact Modelling Consortium at Imperial College funded by the Gates Foundation and GAVI, the 'vaccine alliance', created by Gates as his personal vaccine promotion operation? To compound the human catastrophe that Ferguson's 'models' did so much to create he was later exposed for breaking his own lockdown rules by having sexual liaisons with his married girlfriend Antonia Staats at his home while she was living at another location with her husband and children. Staats was a 'climate' activist and senior campaigner at the Soros-funded Avaaz which I wouldn't trust to tell me that grass is green. Ferguson had to resign as a government advisor over this hypocrisy in May, 2020, but after a period of quiet he was back being quoted by the ridiculous media on the need for more lockdowns and a vaccine rollout. Other government-advising 'scientists' from Imperial College held the fort in his absence and said lockdown could be indefinite until a vaccine was found. The Cult script was being sung by the payrolled choir. I said there was no intention of going back to 'normal' when the 'vaccine' came because the 'vaccine' is part of a very different agenda that I will discuss in Human 2.0. Why would the Cult want to let the world go back to normal when destroying that normal forever was the whole point of what was happening? House arrest, closing businesses and schools through lockdown, (un)social distancing and masks all followed the Ferguson fantasy models. Again as I predicted (these people are so predictable) when the 'vaccine' arrived we were told that house arrest, lockdown, (un)social distancing and masks would still have to continue. I will deal with the masks in the next chapter because they are of fundamental importance.

## **Where's the 'pandemic'?**

Any mildly in-depth assessment of the figures revealed what was really going on. Cult-funded and controlled organisations still have genuine people working within them such is the number involved. So it is with Genevieve Briand, assistant program director of the Applied Economics master's degree program at Johns Hopkins

University. She analysed the impact that 'Covid-19' had on deaths from *all* causes in the United States using official data from the CDC for the period from early February to early September, 2020. She found that allegedly 'Covid' *related*-deaths exceeded those from heart disease which she found strange with heart disease always the biggest cause of fatalities. Her research became even more significant when she noted the sudden decline in 2020 of *all* non-'Covid' deaths: 'This trend is completely contrary to the pattern observed in all previous years ... the total decrease in deaths by other causes almost exactly equals the increase in deaths by Covid-19.' This was such a game, set and match in terms of what was happening that Johns Hopkins University deleted the article on the grounds that it 'was being used to support false and dangerous inaccuracies about the impact of the pandemic'. No – because it exposed the scam from official CDC figures and this was confirmed when those figures were published in January, 2021. Here we can see the effect of people dying from heart attacks, cancer, road accidents and gunshot wounds – *anything* – having 'Covid-19' on the death certificate along with those diagnosed from 'symptoms' who had even not tested positive with a test not testing for the 'virus'. I am not kidding with the gunshot wounds, by the way. Brenda Bock, coroner in Grand County, Colorado, revealed that two gunshot victims tested positive for the 'virus' within the previous 30 days and were therefore classified as 'Covid deaths'. Bock said: 'These two people had tested positive for Covid, but that's not what killed them. A gunshot wound is what killed them.' She said she had not even finished her investigation when the state listed the gunshot victims as deaths due to the 'virus'. The death and case figures for 'Covid-19' are an absolute joke and yet they are repeated like parrots by the media, politicians and alleged medical 'experts'. The official Cult narrative is the only show in town.

Genevieve Briand found that deaths from all causes were not exceptional in 2020 compared with previous years and a Spanish magazine published figures that said the same about Spain which was a 'Covid' propaganda hotspot at one point. *Discovery Salud*, a

health and medicine magazine, quoted government figures which showed how 17,000 *fewer* people died in Spain in 2020 than in 2019 and more than 26,000 fewer than in 2018. The age-standardised mortality rate for England and Wales when age distribution is taken into account was significantly lower in 2020 than the 1970s, 80s and 90s, and was only the ninth highest since 2000. Where is the 'pandemic'?

Post mortems and autopsies virtually disappeared for 'Covid' deaths amid claims that 'virus-infected' bodily fluids posed a risk to those carrying out the autopsy. This was rejected by renowned German pathologist and forensic doctor Klaus Püschel who said that he and his staff had by then done 150 autopsies on 'Covid' patients with no problems at all. He said they were needed to know why some 'Covid' patients suffered blood clots and not severe respiratory infections. The 'virus' is, after all, called SARS or 'severe acute respiratory syndrome'. I highlighted in the spring of 2020 this phenomenon and quoted New York intensive care doctor Cameron Kyle-Sidell who posted a soon deleted YouTube video to say that they had been told to prepare to treat an infectious disease called 'Covid-19', but that was not what they were dealing with. Instead he likened the lung condition of the most severely ill patients to what you would expect with cabin depressurisation in a plane at 30,000 feet or someone dropped on the top of Everest without oxygen or acclimatisation. I have never said this is not happening to a small minority of alleged 'Covid' patients – I am saying this is not caused by a phantom 'contagious virus'. Indeed Kyle-Sidell said that 'Covid-19' was not the disease they were told was coming their way. 'We are operating under a medical paradigm that is untrue,' he said, and he believed they were treating the wrong disease: 'These people are being slowly starved of oxygen.' Patients would take off their oxygen masks in a state of fear and stress and while they were blue in the face on the brink of death. They did not look like patients dying of pneumonia. You can see why they don't want autopsies when their virus doesn't exist and there is another condition in some people that they don't wish to be uncovered. I should add here that

the 5G system of millimetre waves was being rapidly introduced around the world in 2020 and even more so now as they fire 5G at the Earth from satellites. At 60 gigahertz within the 5G range that frequency interacts with the oxygen molecule and stops people breathing in sufficient oxygen to be absorbed into the bloodstream. They are installing 5G in schools and hospitals. The world is not mad or anything. 5G can cause major changes to the lungs and blood as I detail in *The Answer* and these consequences are labelled 'Covid-19', the alleged symptoms of which can be caused by 5G and other electromagnetic frequencies as cells respond to radiation poisoning.

### **The 'Covid death' scam**

Dr Scott Jensen, a Minnesota state senator and medical doctor, exposed 'Covid' Medicare payment incentives to hospitals and death certificate manipulation. He said he was sent a seven-page document by the US Department of Health 'coaching' him on how to fill out death certificates which had never happened before. The document said that he didn't need to have a laboratory test for 'Covid-19' to put that on the death certificate and that shocked him when death certificates are supposed to be about facts. Jensen described how doctors had been 'encouraged, if not pressured' to make a diagnosis of 'Covid-19' if they thought it was probable or '*presumed*'. No positive test was necessary – not that this would have mattered anyway. He said doctors were told to diagnose 'Covid' by symptoms when these were the same as colds, allergies, other respiratory problems, and certainly with influenza which 'disappeared' in the 'Covid' era. A common sniffle was enough to get the dreaded verdict. Ontario authorities decreed that a single care home resident with *one* symptom from a long list must lead to the isolation of the entire home. Other courageous doctors like Jensen made the same point about death figure manipulation and how deaths by other causes were falling while 'Covid-19 deaths' were rising at the same rate due to re-diagnosis. Their videos rarely survive long on YouTube with its Cult-supporting algorithms courtesy of CEO Susan Wojcicki and her bosses at Google. Figure-tampering was so glaring



and ubiquitous that even officials were letting it slip or outright saying it. UK chief scientific adviser Patrick Vallance said on one occasion that 'Covid' on the death certificate doesn't mean 'Covid' was the cause of death (so why the hell is it there?) and we had the rare sight of a BBC reporter telling the truth when she said: 'Someone could be successfully treated for Covid, in say April, discharged, and then in June, get run over by a bus and die ... That person would still be counted as a Covid death in England.' Yet the BBC and the rest of the world media went on repeating the case and death figures as if they were real. Illinois Public Health Director Dr Ngozi Ezike revealed the deceit while her bosses must have been clenching their buttocks:

If you were in a hospice and given a few weeks to live and you were then found to have Covid that would be counted as a Covid death. [There might be] a clear alternate cause, but it is still listed as a Covid death. So everyone listed as a Covid death doesn't mean that was the cause of the death, but that they had Covid at the time of death.

Yes, a 'Covid virus' never shown to exist and tested for with a test not testing for the 'virus'. In the first period of the pandemic hoax through the spring of 2020 the process began of designating almost everything a 'Covid' death and this has continued ever since. I sat in a restaurant one night listening to a loud conversation on the next table where a family was discussing in bewilderment how a relative who had no symptoms of 'Covid', and had died of a long-term problem, could have been diagnosed a death by the 'virus'. I could understand their bewilderment. If they read this book they will know why this medical fraud has been perpetrated the world over.

### **Some media truth shock**

The media ignored the evidence of death certificate fraud until eventually one columnist did speak out when she saw it first-hand. Bel Mooney is a long-time national newspaper journalist in Britain currently working for the *Daily Mail*. Her article on February 19th, 2021, carried this headline: 'My dad Ted passed three Covid tests

and died of a chronic illness yet he's officially one of Britain's 120,000 victims of the virus and is far from alone ... so how many more are there?' She told how her 99-year-old father was in a care home with a long-standing chronic obstructive pulmonary disease and vascular dementia. Maybe, but he was still aware enough to tell her from the start that there was no 'virus' and he refused the 'vaccine' for that reason. His death was not unexpected given his chronic health problems and Mooney said she was shocked to find that 'Covid-19' was declared the cause of death on his death certificate. She said this was a 'bizarre and unacceptable untruth' for a man with long-time health problems who had tested negative twice at the home for the 'virus'. I was also shocked by this story although not by what she said. I had been highlighting the death certificate manipulation for ten months. It was the confirmation that a professional full-time journalist only realised this was going on when it affected her directly and neither did she know that whether her dad tested positive or negative was irrelevant with the test not testing for the 'virus'. Where had she been? She said she did not believe in 'conspiracy theories' without knowing I'm sure that this and 'conspiracy theorists' were terms put into widespread circulation by the CIA in the 1960s to discredit those who did not accept the ridiculous official story of the Kennedy assassination. A blanket statement of 'I don't believe in conspiracy theories' is always bizarre. The dictionary definition of the term alone means the world is drowning in conspiracies. What she said was even more daft when her dad had just been affected by the 'Covid' conspiracy. Why else does she think that 'Covid-19' was going on the death certificates of people who died of something else?

To be fair once she saw from personal experience what was happening she didn't mince words. Mooney was called by the care home on the morning of February 9th to be told her father had died in his sleep. When she asked for the official cause of death what came back was 'Covid-19'. Mooney challenged this and was told there had been deaths from Covid on the dementia floor (confirmed by a test not testing for the 'virus') so they considered it 'reasonable

to assume'. 'But doctor,' Mooney rightly protested, 'an assumption isn't a diagnosis.' She said she didn't blame the perfectly decent and sympathetic doctor – 'he was just doing his job'. Sorry, but that's *bullshit*. He wasn't doing his job at all. He was putting a false cause of death on the death certificate and that is a criminal offence for which he should be brought to account and the same with the millions of doctors worldwide who have done the same. They were not doing their job they were following orders and that must not wash at new Nuremberg trials any more than it did at the first ones. Mooney's doctor was 'assuming' (presuming) as he was told to, but 'just following orders' makes no difference to his actions. A doctor's job is to serve the patient and the truth, not follow orders, but that's what they have done all over the world and played a central part in making the 'Covid' hoax possible with all its catastrophic consequences for humanity. Shame on them and they must answer for their actions. Mooney said her disquiet worsened when she registered her father's death by telephone and was told by the registrar there had been very many other cases like hers where 'the deceased' had not tested positive for 'Covid' yet it was recorded as the cause of death. The test may not matter, but those involved at their level *think* it matters and it shows a callous disregard for accurate diagnosis. The pressure to do this is coming from the top of the national 'health' pyramids which in turn obey the World Health Organization which obeys Gates and the Cult. Mooney said the registrar agreed that this must distort the national figures adding that 'the strangest thing is that every winter we record countless deaths from flu, and this winter there have been none. Not one!' She asked if the registrar thought deaths from flu were being misdiagnosed and lumped together with 'Covid' deaths. The answer was a 'puzzled yes'. Mooney said that the funeral director said the same about 'Covid' deaths which had nothing to do with 'Covid'. They had lost count of the number of families upset by this and other funeral companies in different countries have had the same experience. Mooney wrote:

The nightly shroud-waving and shocking close-ups of pain imposed on us by the TV news bewildered and terrified the population into eager compliance with lockdowns. We were invited to 'save the NHS' and to grieve for strangers – the real-life loved ones behind those shocking death counts. Why would the public imagine what I now fear, namely that the way Covid-19 death statistics are compiled might make the numbers seem greater than they are?

Oh, just a little bit – like 100 percent.

## **Do the maths**

Mooney asked why a country would wish to skew its mortality figures by wrongly certifying deaths? What had been going on? Well, if you don't believe in conspiracies you will never find the answer which is that *it's a conspiracy*. She did, however, describe what she had discovered as a 'national scandal'. In reality it's a global scandal and happening everywhere. Pillars of this conspiracy were all put into place before the button was pressed with the Drosten PCR protocol and high amplifications to produce the cases and death certificate changes to secure illusory 'Covid' deaths. Mooney notes that normally two doctors were needed to certify a death, with one having to know the patient, and how the rules were changed in the spring of 2020 to allow one doctor to do this. In the same period 'Covid deaths' were decreed to be all cases where Covid-19 was put on the death certificate even without a positive test or any symptoms. Mooney asked: 'How many of the 30,851 (as of January 15) care home resident deaths with Covid-19 on the certificate (32.4 per cent of all deaths so far) were based on an assumption, like that of my father? And what has that done to our national psyche?' All of them is the answer to the first question and it has devastated and dismantled the national psyche, actually the global psyche, on a colossal scale. In the UK case and death data is compiled by organisations like Public Health England (PHE) and the Office for National Statistics (ONS). Mooney highlights the insane policy of counting a death from any cause as 'Covid-19' if this happens within 28 days of a positive test (with a test not testing for the 'virus') and she points out that ONS statistics reflect deaths 'involving Covid' 'or due to Covid' which meant in practice any

death where 'Covid-19' was mentioned on the death certificate. She described the consequences of this fraud:

Most people will accept the narrative they are fed, so panicky governments here and in Europe witnessed the harsh measures enacted in totalitarian China and jumped into lockdown. Headlines about Covid deaths tolled like the knell that would bring doomsday to us all. Fear stalked our empty streets. Politicians parroted the frankly ridiculous aim of 'zero Covid' and shut down the economy, while most British people agreed that lockdown was essential and (astonishingly to me, as a patriotic Brit) even wanted more restrictions.

For what? Lies on death certificates? Never mind the grim toll of lives ruined, suicides, schools closed, rising inequality, depression, cancelled hospital treatments, cancer patients in a torture of waiting, poverty, economic devastation, loneliness, families kept apart, and so on. How many lives have been lost as a direct result of lockdown?

She said that we could join in a national chorus of shock and horror at reaching the 120,000 death toll which was surely certain to have been totally skewed all along, but what about the human cost of lockdown justified by these 'death figures'? *The British Medical Journal* had reported a 1,493 percent increase in cases of children taken to Great Ormond Street Hospital with abusive head injuries alone and then there was the effect on families:

Perhaps the most shocking thing about all this is that families have been kept apart – and obeyed the most irrational, changing rules at the whim of government – because they believed in the statistics. They succumbed to fear, which his generation rejected in that war fought for freedom. Dad (God rest his soul) would be angry. And so am I.

Another theme to watch is that in the winter months when there are more deaths from all causes they focus on 'Covid' deaths and in the summer when the British Lung Foundation says respiratory disease plummets by 80 percent they rage on about 'cases'. Either way fascism on population is always the answer.

## **Nazi eugenics in the 21st century**

Elderly people in care homes have been isolated from their families month after lonely month with no contact with relatives and grandchildren who were banned from seeing them. We were told

that lockdown fascism was to 'protect the vulnerable' like elderly people. At the same time Do Not Resuscitate (DNR) orders were placed on their medical files so that if they needed resuscitation it wasn't done and 'Covid-19' went on their death certificates. Old people were not being 'protected' they were being culled – murdered in truth. DNR orders were being decreed for disabled and young people with learning difficulties or psychological problems. The UK Care Quality Commission, a non-departmental body of the Department of Health and Social Care, found that 34 percent of those working in health and social care were pressured into placing 'do not attempt cardiopulmonary resuscitation' orders on 'Covid' patients who suffered from disabilities and learning difficulties without involving the patient or their families in the decision. UK judges ruled that an elderly woman with dementia should have the DNA-manipulating 'Covid vaccine' against her son's wishes and that a man with severe learning difficulties should have the job despite his family's objections. Never mind that many had already died. The judiciary always supports doctors and government in fascist dictatorships. They wouldn't dare do otherwise. A horrific video was posted showing fascist officers from Los Angeles police forcibly giving the 'Covid' shot to women with special needs who were screaming that they didn't want it. The same fascists are seen giving the jab to a sleeping elderly woman in a care home. This is straight out of the Nazi playbook. Hitler's Nazis committed mass murder of the mentally ill and physically disabled throughout Germany and occupied territories in the programme that became known as Aktion T4, or just T4. Sabbatian-controlled Hitler and his grotesque crazies set out to kill those they considered useless and unnecessary. The Reich Committee for the Scientific Registering of Hereditary and Congenital Illnesses registered the births of babies identified by physicians to have 'defects'. By 1941 alone more than 5,000 children were murdered by the state and it is estimated that in total the number of innocent people killed in Aktion T4 was between 275,000 and 300,000. Parents were told their children had been sent away for 'special treatment' never to return. It is rather pathetic to see claims about plans for new extermination camps being dismissed today

when the same force behind current events did precisely that 80 years ago. Margaret Sanger was a Cult operative who used 'birth control' to sanitise her programme of eugenics. Organisations she founded became what is now Planned Parenthood. Sanger proposed that 'the whole dysgenic population would have its choice of segregation or sterilization'. These included epileptics, 'feeble-minded', and prostitutes. Sanger opposed charity because it perpetuated 'human waste'. She reveals the Cult mentality and if anyone thinks that extermination camps are a 'conspiracy theory' their naivety is touching if breathtakingly stupid.

If you don't believe that doctors can act with callous disregard for their patients it is worth considering that doctors and medical staff agreed to put government-decreed DNR orders on medical files and do nothing when resuscitation is called for. I don't know what you call such people in your house. In mine they are Nazis from the Josef Mengele School of Medicine. Phenomenal numbers of old people have died worldwide from the effects of lockdown, depression, lack of treatment, the 'vaccine' (more later) and losing the will to live. A common response at the start of the manufactured pandemic was to remove old people from hospital beds and transfer them to nursing homes. The decision would result in a mass cull of elderly people in those homes through lack of treatment – *not* 'Covid'. Care home whistleblowers have told how once the 'Covid' era began doctors would not come to their homes to treat patients and they were begging for drugs like antibiotics that often never came. The most infamous example was ordered by New York governor Andrew Cuomo, brother of a moronic CNN host, who amazingly was given an Emmy Award for his handling of the 'Covid crisis' by the ridiculous Wokers that hand them out. Just how ridiculous could be seen in February, 2021, when a Department of Justice and FBI investigation began into how thousands of old people in New York died in nursing homes after being discharged from hospital to make way for 'Covid' patients on Cuomo's say-so – and how he and his staff covered up these facts. This couldn't have happened to a nicer psychopath. Even then there was a 'Covid' spin. Reports said that

thousands of old people who tested positive for 'Covid' in hospital were transferred to nursing homes to both die of 'Covid' and transmit it to others. No – they were in hospital because they were ill and the fact that they tested positive with a test not testing for the 'virus' is irrelevant. They were ill often with respiratory diseases ubiquitous in old people near the end of their lives. Their transfer out of hospital meant that their treatment stopped and many would go on to die.

### **They're old. Who gives a damn?**

I have exposed in the books for decades the Cult plan to cull the world's old people and even to introduce at some point what they call a 'demise pill' which at a certain age everyone would take and be out of here by law. In March, 2021, Spain legalised euthanasia and assisted suicide following the Netherlands, Belgium, Luxembourg and Canada on the Tiptoe to the demise pill. Treatment of old people by many 'care' homes has been a disgrace in the 'Covid' era. There are many, many, caring staff – I know some. There have, however, been legions of stories about callous treatment of old people and their families. Police were called when families came to take their loved ones home in the light of isolation that was killing them. They became prisoners of the state. Care home residents in insane, fascist Ontario, Canada, were not allowed to leave their *room* once the 'Covid' hoax began. UK staff have even wheeled elderly people away from windows where family members were talking with them. Oriana Criscuolo from Stockport in the English North West dropped off some things for her 80-year-old father who has Parkinson's disease and dementia and she wanted to wave to him through a ground-floor window. She was told that was 'illegal'. When she went anyway they closed the curtains in the middle of the day. Oriana said:

It's just unbelievable. I cannot understand how care home staff – people who are being paid to care – have become so uncaring. Their behaviour is inhumane and cruel. It's beyond belief.



She was right and this was not a one-off. What a way to end your life in such loveless circumstances. UK registered nurse Nicky Millen, a proper old school nurse for 40 years, said that when she started her career care was based on dignity, choice, compassion and empathy. Now she said 'the things that are important to me have gone out of the window.' She was appalled that people were dying without their loved ones and saying goodbye on iPads. Nicky described how a distressed 89-year-old lady stroked her face and asked her 'how many paracetamol would it take to finish me off'. Life was no longer worth living while not seeing her family. Nicky said she was humiliated in front of the ward staff and patients for letting the lady stroke her face and giving her a cuddle. Such is the dehumanisation that the 'Covid' hoax has brought to the surface. Nicky worked in care homes where patients told her they were being held prisoner. 'I want to live until I die', one said to her. 'I had a lady in tears because she hadn't seen her great-grandson.' Nicky was compassionate old school meeting psychopathic New Normal. She also said she had worked on a 'Covid' ward with no 'Covid' patients. Jewish writer Shai Held wrote an article in March, 2020, which was headlined 'The Staggering, Heartless Cruelty Toward the Elderly'. What he described was happening from the earliest days of lockdown. He said 'the elderly' were considered a group and not unique individuals (the way of the Woke). Shai Held said:

Notice how the all-too-familiar rhetoric of dehumanization works: 'The elderly' are bunched together as a faceless mass, all of them considered culprits and thus effectively deserving of the suffering the pandemic will inflict upon them. Lost entirely is the fact that the elderly are individual human beings, each with a distinctive face and voice, each with hopes and dreams, memories and regrets, friendships and marriages, loves lost and loves sustained.

'The elderly' have become another dehumanised group for which anything goes and for many that has resulted in cold disregard for their rights and their life. The distinctive face that Held talks about is designed to be deleted by masks until everyone is part of a faceless mass.

## **'War-zone' hospitals myth**

Again and again medical professionals have told me what was really going on and how hospitals 'overrun like war zones' according to the media were virtually empty. The mantra from medical whistleblowers was please don't use my name or my career is over. Citizen journalists around the world sneaked into hospitals to film evidence exposing the 'war-zone' lie. They really *were* largely empty with closed wards and operating theatres. I met a hospital worker in my town on the Isle of Wight during the first lockdown in 2020 who said the only island hospital had never been so quiet. Lockdown was justified by the psychopaths to stop hospitals being overrun. At the same time that the island hospital was near-empty the military arrived here to provide *extra beds*. It was all propaganda to ramp up the fear to ensure compliance with fascism as were never-used temporary hospitals with thousands of beds known as Nightingales and never-used make-shift mortuaries opened by the criminal UK government. A man who helped to install those extra island beds attributed to the army said they were never used and the hospital was empty. Doctors and nurses 'stood around talking or on their phones, wandering down to us to see what we were doing'. There were no masks or social distancing. He accused the useless local island paper, the *County Press*, of 'pumping the fear as if our hospital was overrun and we only have one so it should have been'. He described ambulances parked up with crews outside in deck chairs. When his brother called an ambulance he was told there was a two-hour backlog which he called 'bullshit'. An old lady on the island fell 'and was in a bad way', but a caller who rang for an ambulance was told the situation wasn't urgent enough. Ambulance stations were working under capacity while people would hear ambulances with sirens blaring driving through the streets. When those living near the stations realised what was going on they would follow them as they left, circulated around an urban area with the sirens going, and then came back without stopping. All this was to increase levels of fear and the same goes for the 'ventilator shortage crisis' that cost tens of millions for hastily produced ventilators never to be used.

Ambulance crews that agreed to be exploited in this way for fear propaganda might find themselves a mirror. I wish them well with that. Empty hospitals were the obvious consequence of treatment and diagnoses of non-'Covid' conditions cancelled and those involved handed a death sentence. People have been dying at home from undiagnosed and untreated cancer, heart disease and other life-threatening conditions to allow empty hospitals to deal with a 'pandemic' that wasn't happening.

## **Death of the innocent**

'War-zones' have been laying off nursing staff, even doctors where they can. There was no work for them. Lockdown was justified by saving lives and protecting the vulnerable they were actually killing with DNR orders and preventing empty hospitals being 'overrun'. In Britain the mantra of stay at home to 'save the NHS' was everywhere and across the world the same story was being sold when it was all lies. Two California doctors, Dan Erickson and Artin Massihi at Accelerated Urgent Care in Bakersfield, held a news conference in April, 2020, to say that intensive care units in California were 'empty, essentially', with hospitals shutting floors, not treating patients and laying off doctors. The California health system was working at minimum capacity 'getting rid of doctors because we just don't have the volume'. They said that people with conditions such as heart disease and cancer were not coming to hospital out of fear of 'Covid-19'. Their video was deleted by Susan Wojcicki's Cult-owned YouTube after reaching five million views. Florida governor Ron Desantis, who rejected the severe lockdowns of other states and is being targeted for doing so, said that in March, 2020, every US governor was given models claiming they would run out of hospital beds in days. That was never going to happen and the 'modellers' knew it. Deceit can be found at every level of the system. Urgent children's operations were cancelled including fracture repairs and biopsies to spot cancer. Eric Nicholls, a consultant paediatrician, said 'this is obviously concerning and we need to return to normal operating and to increase capacity as soon as possible'. Psychopaths

in power were rather less concerned *because* they are psychopaths. Deletion of urgent care and diagnosis has been happening all over the world and how many kids and others have died as a result of the actions of these cold and heartless lunatics dictating 'health' policy? The number must be stratospheric. Richard Sullivan, professor of cancer and global health at King's College London, said people feared 'Covid' more than cancer such was the campaign of fear. 'Years of lost life will be quite dramatic', Sullivan said, with 'a huge amount of avoidable mortality'. Sarah Woolnough, executive director for policy at Cancer Research UK, said there had been a 75 percent drop in urgent referrals to hospitals by family doctors of people with suspected cancer. Sullivan said that 'a lot of services have had to scale back – we've seen a dramatic decrease in the amount of elective cancer surgery'. Lockdown deaths worldwide has been absolutely fantastic with the *New York Post* reporting how data confirmed that 'lockdowns end more lives than they save':

There was a sharp decline in visits to emergency rooms and an increase in fatal heart attacks because patients didn't receive prompt treatment. Many fewer people were screened for cancer. Social isolation contributed to excess deaths from dementia and Alzheimer's.

Researchers predicted that the social and economic upheaval would lead to tens of thousands of "deaths of despair" from drug overdoses, alcoholism and suicide. As unemployment surged and mental-health and substance-abuse treatment programs were interrupted, the reported levels of anxiety, depression and suicidal thoughts increased dramatically, as did alcohol sales and fatal drug overdoses.

This has been happening while nurses and other staff had so much time on their hands in the 'war-zones' that Tic-Tok dancing videos began appearing across the Internet with medical staff dancing around in empty wards and corridors as people died at home from causes that would normally have been treated in hospital.

## **Mentions in dispatches**

One brave and truth-committed whistleblower was Louise Hampton, a call handler with the UK NHS who made a viral Internet video saying she had done 'fuck all' during the 'pandemic'

which was 'a load of bollocks'. She said that 'Covid-19' was rebranded flu and of course she lost her job. This is what happens in the medical and endless other professions now when you tell the truth. Louise filmed inside 'war-zone' accident and emergency departments to show they were empty and I mean *empty* as in no one there. The mainstream media could have done the same and blown the gaff on the whole conspiracy. They haven't to their eternal shame. Not that most 'journalists' seem capable of manifesting shame as with the psychopaths they slavishly repeat without question. The relative few who were admitted with serious health problems were left to die alone with no loved ones allowed to see them because of 'Covid' rules and they included kids dying without the comfort of mum and dad at their bedside while the evil behind this couldn't give a damn. It was all good fun to them. A Scottish NHS staff nurse publicly quit in the spring of 2021 saying: 'I can no longer be part of the lies and the corruption by the government.' She said hospitals 'aren't full, the beds aren't full, beds have been shut, wards have been shut'. Hospitals were never busy throughout 'Covid'. The staff nurse said that Nicola Sturgeon, tragically the leader of the Scottish government, was on television saying save the hospitals and the NHS – 'but the beds are empty' and 'we've not seen flu, we always see flu every year'. She wrote to government and spoke with her union Unison (the unions are Cult-compromised and *useless*, but nothing changed. Many of her colleagues were scared of losing their jobs if they spoke out as they wanted to. She said nursing staff were being affected by wearing masks all day and 'my head is splitting every shift from wearing a mask'. The NHS is part of the fascist tyranny and must be dismantled so we can start again with human beings in charge. (Ironically, hospitals were reported to be busier again when official 'Covid' cases *fell* in spring/summer of 2021 and many other conditions required treatment at the same time as *the fake vaccine rollout*.)

I will cover the 'Covid vaccine' scam in detail later, but it is another indicator of the sickening disregard for human life that I am highlighting here. The DNA-manipulating concoctions do not fulfil

the definition of a 'vaccine', have never been used on humans before and were given only emergency approval because trials were not completed and they continued using the unknowing public. The result was what a NHS senior nurse with responsibility for 'vaccine' procedure said was 'genocide'. She said the 'vaccines' were not 'vaccines'. They had not been shown to be safe and claims about their effectiveness by drug companies were 'poetic licence'. She described what was happening as a 'horrid act of human annihilation'. The nurse said that management had instigated a policy of not providing a Patient Information Leaflet (PIL) before people were 'vaccinated' even though health care professionals are supposed to do this according to protocol. Patients should also be told that they are taking part in an ongoing clinical trial. Her challenges to what is happening had seen her excluded from meetings and ridiculed in others. She said she was told to 'watch my step ... or I would find myself surplus to requirements'. The nurse, who spoke anonymously in fear of her career, said she asked her NHS manager why he/she was content with taking part in genocide against those having the 'vaccines'. The reply was that everyone had to play their part and to 'put up, shut up, and get it done'. Government was 'leaning heavily' on NHS management which was clearly leaning heavily on staff. This is how the global 'medical' hierarchy operates and it starts with the Cult and its World Health Organization.

She told the story of a doctor who had the Pfizer jab and when questioned had no idea what was in it. The doctor had never read the literature. We have to stop treating doctors as intellectual giants when so many are moral and medical pygmies. The doctor did not even know that the 'vaccines' were not fully approved or that their trials were ongoing. They were, however, asking their patients if they minded taking part in follow-ups for research purposes – yes, the *ongoing clinical trial*. The nurse said the doctor's ignorance was not rare and she had spoken to a hospital consultant who had the jab without any idea of the background or that the 'trials' had not been completed. Nurses and pharmacists had shown the same ignorance.

'My NHS colleagues have forsaken their duty of care, broken their code of conduct – Hippocratic Oath – and have been brainwashed just the same as the majority of the UK public through propaganda ...' She said she had not been able to recruit a single NHS colleague, doctor, nurse or pharmacist to stand with her and speak out. Her union had refused to help. She said that if the genocide came to light she would not hesitate to give evidence at a Nuremberg-type trial against those in power who could have affected the outcomes but didn't.

### **And all for what?**

To put the nonsense into perspective let's say the 'virus' does exist and let's go completely crazy and accept that the official manipulated figures for cases and deaths are accurate. *Even then* a study by Stanford University epidemiologist Dr John Ioannidis published on the World Health Organization website produced an average infection to fatality rate of ... *0.23 percent!* Ioannidis said: 'If one could sample equally from all locations globally, the median infection fatality rate might even be substantially lower than the 0.23% observed in my analysis.' For healthy people under 70 it was ... *0.05 percent!* This compares with the 3.4 percent claimed by the Cult-owned World Health Organization when the hoax was first played and maximum fear needed to be generated. An updated Stanford study in April, 2021, put the 'infection' to 'fatality' rate at just 0.15 percent. Another team of scientists led by Megan O'Driscoll and Henrik Salje studied data from 45 countries and published their findings on the Nature website. For children and young people the figure is so small it virtually does not register although authorities will be hyping dangers to the young when they introduce DNA-manipulating 'vaccines' for children. The O'Driscoll study produced an average infection-fatality figure of 0.003 for children from birth to four; 0.001 for 5 to 14; 0.003 for 15 to 19; and it was still only 0.456 up to 64. To claim that children must be 'vaccinated' to protect them from 'Covid' is an obvious lie and so there must be another reason and there is. What's more the average age of a 'Covid' death is akin

to the average age that people die in general. The average age of death in England is about 80 for men and 83 for women. The average age of death from alleged 'Covid' is between 82 and 83. California doctors, Dan Erickson and Artin Massihi, said at their April media conference that projection models of millions of deaths had been 'woefully inaccurate'. They produced detailed figures showing that Californians had a 0.03 chance of dying from 'Covid' based on the number of people who tested positive (with a test not testing for the 'virus'). Erickson said there was a 0.1 percent chance of dying from 'Covid' in the *state* of New York, not just the city, and a 0.05 percent chance in Spain, a centre of 'Covid-19' hysteria at one stage. The Stanford studies supported the doctors' data with fatality rate estimates of 0.23 and 0.15 percent. How close are these figures to my estimate of *zero*? Death-rate figures claimed by the World Health Organization at the start of the hoax were some 15 times higher. The California doctors said there was no justification for lockdowns and the economic devastation they caused. Everything they had ever learned about quarantine was that you quarantine the *sick* and not the healthy. They had never seen this before and it made no medical sense.

Why in the in the light of all this would governments and medical systems the world over say that billions must go under house arrest; lose their livelihood; in many cases lose their mind, their health and their life; force people to wear masks dangerous to health and psychology; make human interaction and even family interaction a criminal offence; ban travel; close restaurants, bars, watching live sport, concerts, theatre, and any activity involving human togetherness and discourse; and closing schools to isolate children from their friends and cause many to commit suicide in acts of hopelessness and despair? The California doctors said lockdown consequences included increased child abuse, partner abuse, alcoholism, depression, and other impacts they were seeing every day. Who would do that to the entire human race if not mentally-ill psychopaths of almost unimaginable extremes like Bill Gates? We must face the reality of what we are dealing with and come out of



denial. Fascism and tyranny are made possible only by the target population submitting and acquiescing to fascism and tyranny. The whole of human history shows that to be true. Most people naively and unquestioning believed what they were told about a 'deadly virus' and meekly and weakly submitted to house arrest. Those who didn't believe it – at least in total – still submitted in fear of the consequences of not doing so. For the rest who wouldn't submit draconian fines have been imposed, brutal policing by psychopaths *for* psychopaths, and condemnation from the meek and weak who condemn the Pushbackers on behalf of the very force that has them, too, in its gunights. 'Pathetic' does not even begin to suffice. Britain's brainless 'Health' Secretary Matt Hancock warned anyone lying to border officials about returning from a list of 'hotspot' countries could face a jail sentence of up to ten years which is more than for racially-aggravated assault, incest and attempting to have sex with a child under 13. Hancock is a lunatic, but he has the state apparatus behind him in a Cult-led chain reaction and the same with UK 'Vaccine Minister' Nadhim Zahawi, a prominent member of the mega-Cult secret society, Le Cercle, which featured in my earlier books. The Cult enforces its will on governments and medical systems; government and medical systems enforce their will on business and police; business enforces its will on staff who enforce it on customers; police enforce the will of the Cult on the population and play their essential part in creating a world of fascist control that their own children and grandchildren will have to live in their entire lives. It is a hierarchical pyramid of imposition and acquiescence and, yes indeed, of clinical insanity.

Does anyone bright enough to read this book have to ask what the answer is? I think not, but I will reveal it anyway in the fewest of syllables: Tell the psychos and their moronic lackeys to fuck off and let's get on with our lives. We are many – They are few.

## CHAPTER SEVEN

### **War on your mind**

*One believes things because one has been conditioned to believe them*

*Aldous Huxley, Brave New World*

I have described the 'Covid' hoax as a 'Psyop' and that is true in every sense and on every level in accordance with the definition of that term which is psychological warfare. Break down the 'Covid pandemic' to the foundation themes and it is psychological warfare on the human individual and collective mind.

The same can be said for the entire human belief system involving every subject you can imagine. Huxley was right in his contention that people believe what they are conditioned to believe and this comes from the repetition throughout their lives of the same falsehoods. They spew from government, corporations, media and endless streams of 'experts' telling you what the Cult wants you to believe and often believing it themselves (although *far* from always). 'Experts' are rewarded with 'prestigious' jobs and titles and as agents of perceptual programming with regular access to the media. The Cult has to control the narrative – control *information* – or they lose control of the vital, crucial, without-which-they-cannot-prevail public perception of reality. The foundation of that control today is the Internet made possible by the Defense Advanced Research Projects Agency (DARPA), the incredibly sinister technological arm of the Pentagon. The Internet is the result of military technology.

DARPA openly brags about establishing the Internet which has been a long-term project to lasso the minds of the global population. I have said for decades the plan is to control information to such an extreme that eventually no one would see or hear anything that the Cult does not approve. We are closing in on that end with ferocious censorship since the 'Covid' hoax began and in my case it started back in the 1990s in terms of books and speaking venues. I had to create my own publishing company in 1995 precisely because no one else would publish my books even then. I think they're all still running.

## **Cult Internet**

To secure total control of information they needed the Internet in which pre-programmed algorithms can seek out 'unclean' content for deletion and even stop it being posted in the first place. The Cult had to dismantle print and non-Internet broadcast media to ensure the transfer of information to the appropriate-named 'Web' – a critical expression of the *Cult* web. We've seen the ever-quickening demise of traditional media and control of what is left by a tiny number of corporations operating worldwide. Independent journalism in the mainstream is already dead and never was that more obvious than since the turn of 2020. The Cult wants all information communicated via the Internet to globally censor and allow the plug to be pulled any time. Lockdowns and forced isolation has meant that communication between people has been through electronic means and no longer through face-to-face discourse and discussion. Cult psychopaths have targeted the bars, restaurants, sport, venues and meeting places in general for this reason. None of this is by chance and it's to stop people gathering in any kind of privacy or number while being able to track and monitor all Internet communications and block them as necessary. Even private messages between individuals have been censored by these fascists that control Cult fronts like Facebook, Twitter, Google and YouTube which are all officially run by Sabbatian place-people and from the background by higher-level Sabbatian place people.

Facebook, Google, Amazon and their like were seed-funded and supported into existence with money-no-object infusions of funds either directly or indirectly from DARPA and CIA technology arm In-Q-Tel. The Cult plays the long game and prepares very carefully for big plays like 'Covid'. Amazon is another front in the psychological war and pretty much controls the global market in book sales and increasingly publishing. Amazon's limitless funds have deleted fantastic numbers of independent publishers to seize global domination on the way to deciding which books can be sold and circulated and which cannot. Moves in that direction are already happening. Amazon's leading light Jeff Bezos is the grandson of Lawrence Preston Gise who worked with DARPA predecessor ARPA. Amazon has big connections to the CIA and the Pentagon. The plan I have long described went like this:

1. Employ military technology to establish the Internet.
2. Sell the Internet as a place where people can freely communicate without censorship and allow that to happen until the Net becomes the central and irreversible pillar of human society. If the Internet had been highly censored from the start many would have rejected it.
3. Fund and manipulate major corporations into being to control the circulation of information on your Internet using cover stories about geeks in garages to explain how they came about. Give them unlimited funds to expand rapidly with no need to make a profit for years while non-Cult companies who need to balance the books cannot compete. You know that in these circumstances your Googles, YouTubes, Facebooks and Amazons are going to secure near monopolies by either crushing or buying up the opposition.
4. Allow freedom of expression on both the Internet and communication platforms to draw people in until the Internet is the central and irreversible pillar of human society and your communication corporations have reached a stage of near monopoly domination.
5. Then unleash your always-planned frenzy of censorship on the basis of 'where else are you going to go?' and continue to expand that until nothing remains that the Cult does not want its human targets to see.

The process was timed to hit the 'Covid' hoax to ensure the best chance possible of controlling the narrative which they knew they had to do at all costs. They were, after all, about to unleash a 'deadly virus' that didn't really exist. If you do that in an environment of free-flowing information and opinion you would be dead in the

water before you could say Gates is a psychopath. The network was in place through which the Cult-created-and-owned World Health Organization could dictate the 'Covid' narrative and response policy slavishly supported by Cult-owned Internet communication giants and mainstream media while those telling a different story were censored. Google, YouTube, Facebook and Twitter openly announced that they would do this. What else would we expect from Cult-owned operations like Facebook which former executives have confirmed set out to make the platform more addictive than cigarettes and coldly manipulates emotions of its users to sow division between people and groups and scramble the minds of the young? If Zuckerberg lives out the rest of his life without going to jail for crimes against humanity, and most emphatically against the young, it will be a travesty of justice. Still, no matter, cause and effect will catch up with him eventually and the same with Sergey Brin and Larry Page at Google with its CEO Sundar Pichai who fix the Google search results to promote Cult narratives and hide the opposition. Put the same key words into Google and other search engines like DuckDuckGo and you will see how different results can be. Wikipedia is another intensely biased 'encyclopaedia' which skews its content to the Cult agenda. YouTube links to Wikipedia's version of 'Covid' and 'climate change' on video pages in which experts in their field offer a different opinion (even that is increasingly rare with Wojcicki censorship). Into this 'Covid' silence-them network must be added government media censors, sorry 'regulators', such as Ofcom in the UK which imposed tyrannical restrictions on British broadcasters that had the effect of banning me from ever appearing. Just to debate with me about my evidence and views on 'Covid' would mean breaking the fascistic impositions of Ofcom and its CEO career government bureaucrat Melanie Dawes. Gutless British broadcasters tremble at the very thought of fascist Ofcom.

## **Psychos behind 'Covid'**

The reason for the 'Covid' catastrophe in all its facets and forms can be seen by whom and what is driving the policies worldwide in such a coordinated way. Decisions are not being made to protect health, but to target psychology. The dominant group guiding and 'advising' government policy are not medical professionals. They are psychologists and behavioural scientists. Every major country has its own version of this phenomenon and I'll use the British example to show how it works. In many ways the British version has been affecting the wider world in the form of the huge behaviour manipulation network in the UK which operates in other countries. The network involves private companies, government, intelligence and military. The Cabinet Office is at the centre of the government 'Covid' Psyop and part-owns, with 'innovation charity' Nesta, the Behavioural Insights Team (BIT) which claims to be independent of government but patently isn't. The BIT was established in 2010 and its job is to manipulate the psyche of the population to acquiesce to government demands and so much more. It is also known as the 'Nudge Unit', a name inspired by the 2009 book by two ultra-Zionists, Cass Sunstein and Richard Thaler, called *Nudge: Improving Decisions About Health, Wealth, and Happiness*. The book, as with the Behavioural Insights Team, seeks to 'nudge' behaviour (manipulate it) to make the public follow patterns of action and perception that suit those in authority (the Cult). Sunstein is so skilled at this that he advises the World Health Organization and the UK Behavioural Insights Team and was Administrator of the White House Office of Information and Regulatory Affairs in the Obama administration. Biden appointed him to the Department of Homeland Security – another ultra-Zionist in the fold to oversee new immigration laws which is another policy the Cult wants to control. Sunstein is desperate to silence anyone exposing conspiracies and co-authored a 2008 report on the subject in which suggestions were offered to ban 'conspiracy theorizing' or impose 'some kind of tax, financial or otherwise, on those who disseminate such theories'. I guess a psychiatrist's chair is out of the question?

Sunstein's mate Richard Thaler, an 'academic affiliate' of the UK Behavioural Insights Team, is a proponent of 'behavioural economics' which is defined as the study of 'the effects of psychological, cognitive, emotional, cultural and social factors on the decisions of individuals and institutions'. Study the effects so they can be manipulated to be what you want them to be. Other leading names in the development of behavioural economics are ultra-Zionists Daniel Kahneman and Robert J. Shiller and they, with Thaler, won the Nobel Memorial Prize in Economic Sciences for their work in this field. The Behavioural Insights Team is operating at the heart of the UK government and has expanded globally through partnerships with several universities including Harvard, Oxford, Cambridge, University College London (UCL) and Pennsylvania. They claim to have 'trained' (reframed) 20,000 civil servants and run more than 750 projects involving 400 randomised controlled trials in dozens of countries' as another version of mind reframers Common Purpose. BIT works from its office in New York with cities and their agencies, as well as other partners, across the United States and Canada – this is a company part-owned by the British government Cabinet Office. An executive order by President Cult-servant Obama established a US Social and Behavioral Sciences Team in 2015. They all have the same reason for being and that's to brainwash the population directly and by brainwashing those in positions of authority.

### **'Covid' mind game**

Another prime aspect of the UK mind-control network is the 'independent' [joke] Scientific Pandemic Insights Group on Behaviours (SPI-B) which 'provides behavioural science advice aimed at anticipating and helping people adhere to interventions that are recommended by medical or epidemiological experts'. That means manipulating public perception and behaviour to do whatever government tells them to do. It's disgusting and if they really want the public to be 'safe' this lot should all be under lock and key. According to the government website SPI-B consists of

'behavioural scientists, health and social psychologists, anthropologists and historians' and advises the Whitty-Vallance-led Scientific Advisory Group for Emergencies (SAGE) which in turn advises the government on 'the science' (it doesn't) and 'Covid' policy. When politicians say they are being guided by 'the science' this is the rabble in each country they are talking about and that 'science' is dominated by behaviour manipulators to enforce government fascism through public compliance. The Behaviour Insight Team is headed by psychologist David Solomon Halpern, a visiting professor at King's College London, and connects with a national and global web of other civilian and military organisations as the Cult moves towards its goal of fusing them into one fascistic whole in every country through its 'Fusion Doctrine'. The behaviour manipulation network involves, but is not confined to, the Foreign Office; National Security Council; government communications headquarters (GCHQ); MI5; MI6; the Cabinet Office-based Media Monitoring Unit; and the Rapid Response Unit which 'monitors digital trends to spot emerging issues; including misinformation and disinformation; and identifies the best way to respond'.

There is also the 77th Brigade of the UK military which operates like the notorious Israeli military's Unit 8200 in manipulating information and discussion on the Internet by posing as members of the public to promote the narrative and discredit those who challenge it. Here we have the military seeking to manipulate *domestic* public opinion while the Nazis in government are fine with that. Conservative Member of Parliament Tobias Ellwood, an advocate of lockdown and control through 'vaccine passports', is a Lieutenant Colonel reservist in the 77th Brigade which connects with the military operation jHub, the 'innovation centre' for the Ministry of Defence and Strategic Command. jHub has also been involved with the civilian National Health Service (NHS) in 'symptom tracing' the population. The NHS is a key part of this mind control network and produced a document in December, 2020, explaining to staff how to use psychological manipulation with different groups and ages to get them to have the DNA-manipulating 'Covid vaccine'



that's designed to cumulatively rewrite human genetics. The document, called 'Optimising Vaccination Roll Out – Do's and Dont's for all messaging, documents and "communications" in the widest sense', was published by NHS England and the NHS Improvement *Behaviour Change Unit* in partnership with Public Health England and Warwick Business School. I hear the mantra about 'save the NHS' and 'protect the NHS' when we need to scrap the NHS and start again. The current version is far too corrupt, far too anti-human and totally compromised by Cult operatives and their assets. UK government broadcast media censor Ofcom will connect into this web – as will the BBC with its tremendous Ofcom influence – to control what the public see and hear and dictate mass perception. Nuremberg trials must include personnel from all these organisations.

### **The fear factor**

The 'Covid' hoax has led to the creation of the UK Cabinet Office-connected Joint Biosecurity Centre (JBC) which is officially described as providing 'expert advice on pandemics' using its independent [all Cult operations are 'independent'] analytical function to provide real-time analysis about infection outbreaks to identify and respond to outbreaks of Covid-19'. Another role is to advise the government on a response to spikes in infections – 'for example by closing schools or workplaces in local areas where infection levels have risen'. Put another way, promoting the Cult agenda. The Joint Biosecurity Centre is modelled on the Joint Terrorism Analysis Centre which analyses intelligence to set 'terrorism threat levels' and here again you see the fusion of civilian and military operations and intelligence that has led to military intelligence producing documents about 'vaccine hesitancy' and how it can be combated. Domestic civilian matters and opinions should not be the business of the military. The Joint Biosecurity Centre is headed by Tom Hurd, director general of the Office for Security and Counter-Terrorism from the establishment-to-its-fingertips Hurd family. His father is former Foreign Secretary Douglas Hurd. How coincidental that Tom

Hurd went to the elite Eton College and Oxford University with Boris Johnson. Imperial College with its ridiculous computer modeller Neil Ferguson will connect with this gigantic web that will itself interconnect with similar set-ups in other major and not so major countries. Compared with this Cult network the politicians, be they Boris Johnson, Donald Trump or Joe Biden, are bit-part players 'following the science'. The network of psychologists was on the 'Covid' case from the start with the aim of generating maximum fear of the 'virus' to ensure compliance by the population. A government behavioural science group known as SPI-B produced a paper in March, 2020, for discussion by the main government science advisory group known as SAGE. It was headed 'Options for increasing adherence to social distancing measures' and it said the following in a section headed 'Persuasion':

- A substantial number of people still do not feel sufficiently personally threatened; it could be that they are reassured by the low death rate in their demographic group, although levels of concern may be rising. Having a good understanding of the risk has been found to be positively associated with adoption of COVID-19 social distancing measures in Hong Kong.
- The perceived level of personal threat needs to be increased among those who are complacent, using hard-hitting evaluation of options for increasing social distancing emotional messaging. To be effective this must also empower people by making clear the actions they can take to reduce the threat.
- Responsibility to others: There seems to be insufficient understanding of, or feelings of responsibility about, people's role in transmitting the infection to others ... Messaging about actions need to be framed positively in terms of protecting oneself and the community, and increase confidence that they will be effective.
- Some people will be more persuaded by appeals to play by the rules, some by duty to the community, and some to personal risk.

All these different approaches are needed. The messaging also needs to take account of the realities of different people's lives. Messaging needs to take account of the different motivational levers and circumstances of different people.

All this could be achieved the SPI-B psychologists said by *using the media to increase the sense of personal threat* which translates as terrify the shit out of the population, including children, so they all do what we want. That's not happened has it? Those excuses for 'journalists' who wouldn't know journalism if it bit them on the arse (the great majority) have played their crucial part in serving this Cult-government Psyop to enslave their own kids and grandkids. How they live with themselves I have no idea. The psychological war has been underpinned by constant government 'Covid' propaganda in almost every television and radio ad break, plus the Internet and print media, which has pounded out the fear with taxpayers footing the bill for their own programming. The result has been people terrified of a 'virus' that doesn't exist or one with a tiny fatality rate even if you believe it does. People walk down the street and around the shops wearing face-nappies damaging their health and psychology while others report those who refuse to be that naïve to the police who turn up in their own face-nappies. I had a cameraman come to my flat and he was so frightened of 'Covid' he came in wearing a mask and refused to shake my hand in case he caught something. He had – naïveitis – and the thought that he worked in the mainstream media was both depressing and made his behaviour perfectly explainable. The fear which has gripped the minds of so many and frozen them into compliance has been carefully cultivated by these psychologists who are really psychopaths. If lives get destroyed and a lot of young people commit suicide it shows our plan is working. SPI-B then turned to compulsion on the public to comply. 'With adequate preparation, rapid change can be achieved', it said. Some countries had introduced mandatory self-isolation on a wide scale without evidence of major public unrest and a large majority of the UK's population appeared to be supportive of more coercive measures with 64 percent of adults saying they would

support putting London under a lockdown (watch the 'polls' which are designed to make people believe that public opinion is in favour or against whatever the subject in hand).

For 'aggressive protective measures' to be effective, the SPI-B paper said, special attention should be devoted to those population groups that are more at risk. Translated from the Orwellian this means making the rest of population feel guilty for not protecting the 'vulnerable' such as old people which the Cult and its agencies were about to kill on an industrial scale with lockdown, lack of treatment and the Gates 'vaccine'. Psychopath psychologists sold their guilt-trip so comprehensively that Los Angeles County Supervisor Hilda Solis reported that children were apologising (from a distance) to their parents and grandparents for bringing 'Covid' into their homes and getting them sick. '... These apologies are just some of the last words that loved ones will ever hear as they die alone,' she said. Gut-wrenchingly Solis then used this childhood tragedy to tell children to stay at home and 'keep your loved ones alive'. Imagine heaping such potentially life-long guilt on a kid when it has absolutely nothing to do with them. These people are deeply disturbed and the psychologists behind this even more so.

### **Uncivil war – divide and rule**

Professional mind-controllers at SPI-B wanted the media to increase a sense of responsibility to others (do as you're told) and promote 'positive messaging' for those actions while in contrast to invoke 'social disapproval' by the unquestioning, obedient, community of anyone with a mind of their own. Again the compliant Goebbels-like media obliged. This is an old, old, trick employed by tyrannies the world over throughout human history. You get the target population to keep the target population in line – *your* line. SPI-B said this could 'play an important role in preventing anti-social behaviour or discouraging failure to enact pro-social behaviour'. For 'anti-social' in the Orwellian parlance of SPI-B see any behaviour that government doesn't approve. SPI-B recommendations said that 'social disapproval' should be accompanied by clear messaging and

promotion of strong collective identity – hence the government and celebrity mantra of ‘we’re all in this together’. Sure we are. The mind doctors have such contempt for their targets that they think some clueless comedian, actor or singer telling them to do what the government wants will be enough to win them over. We have had UK comedian Lenny Henry, actor Michael Caine and singer Elton John wheeled out to serve the propagandists by urging people to have the DNA-manipulating ‘Covid’ non-‘vaccine’. The role of Henry and fellow black celebrities in seeking to coax a ‘vaccine’ reluctant black community into doing the government’s will was especially stomach-turning. An emotion-manipulating script and carefully edited video featuring these black ‘celebs’ was such an insult to the intelligence of black people and where’s the self-respect of those involved selling their souls to a fascist government agenda? Henry said he heard black people’s ‘legitimate worries and concerns’, but people must ‘trust the facts’ when they were doing exactly that by not having the ‘vaccine’. They had to include the obligatory reference to Black Lives Matter with the line ... ‘Don’t let coronavirus cost even more black lives – because we matter’. My god, it was pathetic. ‘I know the vaccine is safe and what it does.’ How? ‘I’m a comedian and it says so in my script.’

SPI-B said social disapproval needed to be carefully managed to avoid victimisation, scapegoating and misdirected criticism, but they knew that their ‘recommendations’ would lead to exactly that and the media were specifically used to stir-up the divide-and-conquer hostility. Those who conform like good little baa, baas, are praised while those who have seen through the tidal wave of lies are ‘Covidiot’s’. The awake have been abused by the fast asleep for not conforming to fascism and impositions that the awake know are designed to endanger their health, dehumanise them, and tear asunder the very fabric of human society. We have had the curtain-twitchers and morons reporting neighbours and others to the face-napped police for breaking ‘Covid rules’ with fascist police delighting in posting links and phone numbers where this could be done. The Cult cannot impose its will without a compliant police

and military or a compliant population willing to play their part in enslaving themselves and their kids. The words of a pastor in Nazi Germany are so appropriate today:

First they came for the socialists and I did not speak out because I was not a socialist.

Then they came for the trade unionists and I did not speak out because I was not a trade unionist.

Then they came for the Jews and I did not speak out because I was not a Jew.

Then they came for me and there was no one left to speak for me.

Those who don't learn from history are destined to repeat it and so many are.

### **'Covid' rules: Rewiring the mind**

With the background laid out to this gigantic national and global web of psychological manipulation we can put 'Covid' rules into a clear and sinister perspective. Forget the claims about protecting health. 'Covid' rules are about dismantling the human mind, breaking the human spirit, destroying self-respect, and then putting Humpty Dumpty together again as a servile, submissive slave. Social isolation through lockdown and distancing have devastating effects on the human psyche as the psychological psychopaths well know and that's the real reason for them. Humans need contact with each other, discourse, closeness and touch, or they eventually, and literally, go crazy. Masks, which I will address at some length, fundamentally add to the effects of isolation and the Cult agenda to dehumanise and de-individualise the population. To do this while knowing – in fact *seeking* – this outcome is the very epitome of evil and psychologists involved in this *are* the epitome of evil. They must like all the rest of the Cult demons and their assets stand trial for crimes against humanity on a scale that defies the imagination. Psychopaths in uniform use isolation to break enemy troops and agents and make them subservient and submissive to tell what they know. The technique is rightly considered a form of torture and

torture is most certainly what has been imposed on the human population.

Clinically-insane American psychologist Harry Harlow became famous for his isolation experiments in the 1950s in which he separated baby monkeys from their mothers and imprisoned them for months on end in a metal container or 'pit of despair'. They soon began to show mental distress and depression as any idiot could have predicted. Harlow put other monkeys in steel chambers for three, six or twelve months while denying them any contact with animals or humans. He said that the effects of total social isolation for six months were 'so devastating and debilitating that we had assumed initially that twelve months of isolation would not produce any additional decrement'; but twelve months of isolation 'almost obliterated the animals socially'. This is what the Cult and its psychopaths are doing to you and your children. Even monkeys in partial isolation in which they were not allowed to form relationships with other monkeys became 'aggressive and hostile, not only to others, but also towards their own bodies'. We have seen this in the young as a consequence of lockdown. UK government psychopaths launched a public relations campaign telling people not to hug each other even after they received the 'Covid-19 vaccine' which we were told with more lies would allow a return to 'normal life'. A government source told *The Telegraph*: 'It will be along the lines that it is great that you have been vaccinated, but if you are going to visit your family and hug your grandchildren there is a chance you are going to infect people you love.' The source was apparently speaking from a secure psychiatric facility. Janet Lord, director of Birmingham University's Institute of Inflammation and Ageing, said that parents and grandparents should avoid hugging their children. Well, how can I put it, Ms Lord? Fuck off. Yep, that'll do.

## **Destroying the kids – where are the parents?**

Observe what has happened to people enslaved and isolated by lockdown as suicide and self-harm has soared worldwide,

particularly among the young denied the freedom to associate with their friends. A study of 49,000 people in English-speaking countries concluded that almost half of young adults are at clinical risk of mental health disorders. A national survey in America of 1,000 currently enrolled high school and college students found that 5 percent reported attempting suicide during the pandemic. Data from the US CDC's National Syndromic Surveillance Program from January 1st to October 17th, 2020, revealed a 31 percent increase in mental health issues among adolescents aged 12 to 17 compared with 2019. The CDC reported that America in general suffered the biggest drop in life expectancy since World War Two as it fell by a year in the first half of 2020 as a result of 'deaths of despair' – overdoses and suicides. Deaths of despair have leapt by more than 20 percent during lockdown and include the highest number of fatal overdoses ever recorded in a single year – 81,000. Internet addiction is another consequence of being isolated at home which lowers interest in physical activities as kids fall into inertia and what's the point? Children and young people are losing hope and giving up on life, sometimes literally. A 14-year-old boy killed himself in Maryland because he had 'given up' when his school district didn't reopen; an 11-year-old boy shot himself during a zoom class; a teenager in Maine succumbed to the isolation of the 'pandemic' when he ended his life after experiencing a disrupted senior year at school. Children as young as nine have taken their life and all these stories can be repeated around the world. Careers are being destroyed before they start and that includes those in sport in which promising youngsters have not been able to take part. The plan of the psycho-psychologists is working all right. Researchers at Cambridge University found that lockdowns cause significant harm to children's mental health. Their study was published in the *Archives of Disease in Childhood*, and followed 168 children aged between 7 and 11. The researchers concluded:

During the UK lockdown, children's depression symptoms have increased substantially, relative to before lockdown. The scale of this effect has direct relevance for the continuation of different elements of lockdown policy, such as complete or partial school closures ...



... Specifically, we observed a statistically significant increase in ratings of depression, with a medium-to-large effect size. Our findings emphasise the need to incorporate the potential impact of lockdown on child mental health in planning the ongoing response to the global pandemic and the recovery from it.

Not a chance when the Cult's psycho-psychologists were getting exactly what they wanted. The UK's Royal College of Paediatrics and Child Health has urged parents to look for signs of eating disorders in children and young people after a three to four fold increase. Specialists say the 'pandemic' is a major reason behind the rise. You don't say. The College said isolation from friends during school closures, exam cancellations, loss of extra-curricular activities like sport, and an increased use of social media were all contributory factors along with fears about the virus (psycho-psychologists again), family finances, and students being forced to quarantine. Doctors said young people were becoming severely ill by the time they were seen with 'Covid' regulations reducing face-to-face consultations. Nor is it only the young that have been devastated by the psychopaths. Like all bullies and cowards the Cult is targeting the young, elderly, weak and infirm. A typical story was told by a British lady called Lynn Parker who was not allowed to visit her husband in 2020 for the last ten and half months of his life 'when he needed me most' between March 20th and when he died on December 19th. This vacates the criminal and enters the territory of evil. The emotional impact on the immune system alone is immense as are the number of people of all ages worldwide who have died as a result of Cult-demanded, Gates-demanded, lockdowns.

## **Isolation is torture**

The experience of imposing solitary confinement on millions of prisoners around the world has shown how a large percentage become 'actively psychotic and/or acutely suicidal'. Social isolation has been found to trigger 'a specific psychiatric syndrome, characterized by hallucinations; panic attacks; overt paranoia; diminished impulse control; hypersensitivity to external stimuli; and difficulties with thinking, concentration and memory'. Juan Mendez,

a United Nations rapporteur (investigator), said that isolation is a form of torture. Research has shown that even after isolation prisoners find it far more difficult to make social connections and I remember chatting to a shop assistant after one lockdown who told me that when her young son met another child again he had no idea how to act or what to do. Hannah Flanagan, Director of Emergency Services at Journey Mental Health Center in Dane County, Wisconsin, said: 'The specificity about Covid social distancing and isolation that we've come across as contributing factors to the suicides are really new to us this year.' But they are not new to those that devised them. They are getting the effect they want as the population is psychologically dismantled to be rebuilt in a totally different way. Children and the young are particularly targeted. They will be the adults when the full-on fascist AI-controlled technocracy is planned to be imposed and they are being prepared to meekly submit. At the same time older people who still have a memory of what life was like before – and how fascist the new normal really is – are being deleted. You are going to see efforts to turn the young against the old to support this geriatric genocide. Hannah Flanagan said the big increase in suicide in her county proved that social isolation is not only harmful, but deadly. Studies have shown that isolation from others is one of the main risk factors in suicide and even more so with women. Warnings that lockdown could create a 'perfect storm' for suicide were ignored. After all this was one of the *reasons* for lockdown. Suicide, however, is only the most extreme of isolation consequences. There are many others. Dr Dhruv Khullar, assistant professor of healthcare policy at Weill Cornell Medical College, said in a *New York Times* article in 2016 long before the fake 'pandemic':

A wave of new research suggests social separation is bad for us. Individuals with less social connection have disrupted sleep patterns, altered immune systems, more inflammation and higher levels of stress hormones. One recent study found that isolation increases the risk of heart disease by 29 percent and stroke by 32 percent. Another analysis that pooled data from 70 studies and 3.4 million people found that socially isolated individuals had a 30 percent higher risk of dying in the next seven years, and that this effect was largest in middle age.

Loneliness can accelerate cognitive decline in older adults, and isolated individuals are twice as likely to die prematurely as those with more robust social interactions. These effects start early: Socially isolated children have significantly poorer health 20 years later, even after controlling for other factors. All told, loneliness is as important a risk factor for early death as obesity and smoking.

There you have proof from that one article alone four years before 2020 that those who have enforced lockdown, social distancing and isolation knew what the effect would be and that is even more so with professional psychologists that have been driving the policy across the globe. We can go back even further to the years 2000 and 2003 and the start of a major study on the effects of isolation on health by Dr Janine Gronewold and Professor Dirk M. Hermann at the University Hospital in Essen, Germany, who analysed data on 4,316 people with an average age of 59 who were recruited for the long-term research project. They found that socially isolated people are more than 40 percent more likely to have a heart attack, stroke, or other major cardiovascular event and nearly 50 percent more likely to die from any cause. Given the financial Armageddon unleashed by lockdown we should note that the study found a relationship between increased cardiovascular risk and lack of financial support. After excluding other factors social isolation was still connected to a 44 percent increased risk of cardiovascular problems and a 47 percent increased risk of death by any cause. Lack of financial support was associated with a 30 percent increase in the risk of cardiovascular health events. Dr Gronewold said it had been known for some time that feeling lonely or lacking contact with close friends and family can have an impact on physical health and the study had shown that having strong social relationships is of high importance for heart health. Gronewold said they didn't understand yet why people who are socially isolated have such poor health outcomes, but this was obviously a worrying finding, particularly during these times of prolonged social distancing. Well, it can be explained on many levels. You only have to identify the point in the body where people feel loneliness and missing people they are parted from – it's in the centre of the chest where they feel the ache of loneliness and the ache of missing people. 'My heart aches for

you' ... 'My heart aches for some company.' I will explain this more in the chapter Escaping Wetiko, but when you realise that the body is the mind – they are expressions of each other – the reason why state of the mind dictates state of the body becomes clear.

American psychologist Ranjit Powar was highlighting the effects of lockdown isolation as early as April, 2020. She said humans have evolved to be social creatures and are wired to live in interactive groups. Being isolated from family, friends and colleagues could be unbalancing and traumatic for most people and could result in short or even long-term psychological and physical health problems. An increase in levels of anxiety, aggression, depression, forgetfulness and hallucinations were possible psychological effects of isolation. 'Mental conditions may be precipitated for those with underlying pre-existing susceptibilities and show up in many others without any pre-condition.' Powar said personal relationships helped us cope with stress and if we lost this outlet for letting off steam the result can be a big emotional void which, for an average person, was difficult to deal with. 'Just a few days of isolation can cause increased levels of anxiety and depression' – so what the hell has been the effect on the global population of *18 months* of this at the time of writing? Powar said: 'Add to it the looming threat of a dreadful disease being repeatedly hammered in through the media and you have a recipe for many shades of mental and physical distress.' For those with a house and a garden it is easy to forget that billions have had to endure lockdown isolation in tiny overcrowded flats and apartments with nowhere to go outside. The psychological and physical consequences of this are unimaginable and with lunatic and abusive partners and parents the consequences have led to tremendous increases in domestic and child abuse and alcoholism as people seek to shut out the horror. Ranjit Powar said:

Staying in a confined space with family is not all a rosy picture for everyone. It can be extremely oppressive and claustrophobic for large low-income families huddled together in small single-room houses. Children here are not lucky enough to have many board/electronic games or books to keep them occupied.

Add to it the deep insecurity of running out of funds for food and basic necessities. On the other hand, there are people with dysfunctional family dynamics, such as domineering, abusive or alcoholic partners, siblings or parents which makes staying home a period of trial. Incidence of suicide and physical abuse against women has shown a worldwide increase. Heightened anxiety and depression also affect a person's immune system, making them more susceptible to illness.

To think that Powar's article was published on April 11th, 2020.

## **Six-foot fantasy**

Social (unsocial) distancing demanded that people stay six feet or two metres apart. UK government advisor Robert Dingwall from the New and Emerging Respiratory Virus Threats Advisory Group said in a radio interview that the two-metre rule was 'conjured up out of nowhere' and was not based on science. No, it was not based on *medical* science, but it didn't come out of nowhere. The distance related to *psychological* science. Six feet/two metres was adopted in many countries and we were told by people like the criminal Anthony Fauci and his ilk that it was founded on science. Many schools could not reopen because they did not have the space for six-foot distancing. Then in March, 2021, after a year of six-foot 'science', a study published in the *Journal of Infectious Diseases* involving more than 500,000 students and almost 100,000 staff over 16 weeks revealed no significant difference in 'Covid' cases between six feet and three feet and Fauci changed his tune. Now three feet was okay. There is no difference between six feet and three *inches* when there is no 'virus' and they got away with six feet for psychological reasons for as long as they could. I hear journalists and others talk about 'unintended consequences' of lockdown. They are not *unintended* at all; they have been coldly-calculated for a specific outcome of human control and that's why super-psychopaths like Gates have called for them so vehemently. Super-psychopath psychologists have demanded them and psychopathic or clueless, spineless, politicians have gone along with them by 'following the science'. But it's not science at all. 'Science' is not what is; it's only what people can be manipulated to believe it is. The whole 'Covid' catastrophe is

founded on mind control. Three word or three statement mantras issued by the UK government are a well-known mind control technique and so we've had 'Stay home/protect the NHS/save lives', 'Stay alert/control the virus/save lives' and 'hands/face/space'. One of the most vocal proponents of extreme 'Covid' rules in the UK has been Professor Susan Michie, a member of the British Communist Party, who is not a medical professional. Michie is the director of the Centre for Behaviour Change at University College London. She is a *behavioural psychologist* and another filthy rich 'Marxist' who praised China's draconian lockdown. She was known by fellow students at Oxford University as 'Stalin's nanny' for her extreme Marxism. Michie is an influential member of the UK government's Scientific Advisory Group for Emergencies (SAGE) and behavioural manipulation groups which have dominated 'Covid' policy. She is a consultant adviser to the World Health Organization on 'Covid-19' and behaviour. Why the hell are lockdowns anything to do with her when they are claimed to be about health? Why does a behavioural psychologist from a group charged with changing the behaviour of the public want lockdown, human isolation and mandatory masks? Does that question really need an answer? Michie *absolutely* has to explain herself before a Nuremberg court when humanity takes back its world again and even more so when you see the consequences of masks that she demands are compulsory. This is a Michie classic:

The benefits of getting primary school children to wear masks is that regardless of what little degree of transmission is occurring in those age groups it could help normalise the practice. Young children wearing masks may be more likely to get their families to accept masks.

Those words alone should carry a prison sentence when you ponder on the callous disregard for children involved and what a statement it makes about the mind and motivations of Susan Michie. What a lovely lady and what she said there encapsulates the mentality of the psychopaths behind the 'Covid' horror. Let us compare what Michie said with a countrywide study in Germany published at [researchsquare.com](https://www.researchsquare.com) involving 25,000 school children and 17,854 health complaints submitted by parents. Researchers

found that masks are harming children physically, psychologically, and behaviourally with 24 health issues associated with mask wearing. They include: shortness of breath (29.7%); dizziness (26.4%); increased headaches (53%); difficulty concentrating (50%); drowsiness or fatigue (37%); and malaise (42%). Nearly a third of children experienced more sleep issues than before and a quarter developed new fears. Researchers found health issues and other impairments in 68 percent of masked children covering their faces for an average of 4.5 hours a day. Hundreds of those taking part experienced accelerated respiration, tightness in the chest, weakness, and short-term impairment of consciousness. A reminder of what Michie said again:

The benefits of getting primary school children to wear masks is that regardless of what little degree of transmission is occurring in those age groups it could help normalise the practice. Young children wearing masks may be more likely to get their families to accept masks.

Psychopaths in government and psychology now have children and young people – plus all the adults – wearing masks for hours on end while clueless teachers impose the will of the psychopaths on the young they should be protecting. What the hell are parents doing?

## **Cult lab rats**

We have some schools already imposing on students microchipped buzzers that activate when they get 'too close' to their pals in the way they do with lab rats. How apt. To the Cult and its brain-dead servants our children *are* lab rats being conditioned to be unquestioning, dehumanised slaves for the rest of their lives. Children and young people are being weaned and frightened away from the most natural human instincts including closeness and touch. I have tracked in the books over the years how schools were banning pupils from greeting each other with a hug and the whole Cult-induced Me Too movement has terrified men and boys from a relaxed and natural interaction with female friends and work colleagues to the point where many men try never to be in a room

alone with a woman that's not their partner. Airhead celebrities have as always played their virtue-signalling part in making this happen with their gross exaggeration. For every monster like Harvey Weinstein there are at least tens of thousands of men that don't treat women like that; but everyone must be branded the same and policy changed for them as well as the monster. I am going to be using the word 'dehumanise' many times in this chapter because that is what the Cult is seeking to do and it goes very deep as we shall see. Don't let them kid you that social distancing is planned to end one day. That's not the idea. We are seeing more governments and companies funding and producing wearable gadgets to keep people apart and they would not be doing that if this was meant to be short-term. A tech start-up company backed by GCHQ, the British Intelligence and military surveillance headquarters, has created a social distancing wrist sensor that alerts people when they get too close to others. The CIA has also supported tech companies developing similar devices. The wearable sensor was developed by Tended, one of a number of start-up companies supported by GCHQ (see the CIA and DARPA). The device can be worn on the wrist or as a tag on the waistband and will vibrate whenever someone wearing the device breaches social distancing and gets anywhere near natural human contact. The company had a lucky break in that it was developing a distancing sensor when the 'Covid' hoax arrived which immediately provided a potentially enormous market. How fortunate. The government in big-time Cult-controlled Ontario in Canada is investing \$2.5 million in wearable contact tracing technology that 'will alert users if they may have been exposed to the Covid-19 in the workplace and will beep or vibrate if they are within six feet of another person'. Facedrive Inc., the technology company behind this, was founded in 2016 with funding from the Ontario Together Fund and obviously they, too, had a prophet on the board of directors. The human surveillance and control technology is called TraceSCAN and would be worn by the human cyborgs in places such as airports, workplaces, construction sites, care homes and ... *schools*.



I emphasise schools with children and young people the prime targets. You know what is planned for society as a whole if you keep your eyes on the schools. They have always been places where the state program the next generation of slaves to be its compliant worker-ants – or Woker-ants these days; but in the mist of the ‘Covid’ madness they have been transformed into mind laboratories on a scale never seen before. Teachers and head teachers are just as programmed as the kids – often more so. Children are kept apart from human interaction by walk lanes, classroom distancing, staggered meal times, masks, and the rolling-out of buzzer systems. Schools are now physically laid out as a laboratory maze for lab-rats. Lunatics at a school in Anchorage, Alaska, who should be prosecuted for child abuse, took away desks and forced children to kneel (know your place) on a mat for five hours a day while wearing a mask and using their chairs as a desk. How this was supposed to impact on a ‘virus’ only these clinically insane people can tell you and even then it would be clap-trap. The school banned recess (interaction), art classes (creativity), and physical exercise (getting body and mind moving out of inertia). Everyone behind this outrage should be in jail or better still a mental institution. The behavioural manipulators are all for this dystopian approach to schools. Professor Susan Michie, the mind-doctor and British Communist Party member, said it was wrong to say that schools were safe. They had to be made so by ‘distancing’, masks and ventilation (sitting all day in the cold). I must ask this lady round for dinner on a night I know I am going to be out and not back for weeks. She probably wouldn’t be able to make it, anyway, with all the visits to her own psychologist she must have block-booked.

## **Masking identity**

I know how shocking it must be for you that a behaviour manipulator like Michie wants everyone to wear masks which have long been a feature of mind-control programs like the infamous MKUltra in the United States, but, there we are. We live and learn. I spent many years from 1996 to right across the millennium

researching mind control in detail on both sides of the Atlantic and elsewhere. I met a large number of mind-control survivors and many had been held captive in body and mind by MKUltra. MK stands for mind-control, but employs the German spelling in deference to the Nazis spirited out of Germany at the end of World War Two by Operation Paperclip in which the US authorities, with help from the Vatican, transported Nazi mind-controllers and engineers to America to continue their work. Many of them were behind the creation of NASA and they included Nazi scientist and SS officer Wernher von Braun who swapped designing V-2 rockets to bombard London with designing the Saturn V rockets that powered the NASA moon programme's Apollo craft. I think I may have mentioned that the Cult has no borders. Among Paperclip escapees was Josef Mengele, the Angel of Death in the Nazi concentration camps where he conducted mind and genetic experiments on children often using twins to provide a control twin to measure the impact of his 'work' on the other. If you want to observe the Cult mentality in all its extremes of evil then look into the life of Mengele. I have met many people who suffered mercilessly under Mengele in the United States where he operated under the name Dr Greene and became a stalwart of MKUltra programming and torture. Among his locations was the underground facility in the Mojave Desert in California called the China Lake Naval Weapons Station which is almost entirely below the surface. My books *The Biggest Secret*, *Children of the Matrix* and *The Perception Deception* have the detailed background to MKUltra.

The best-known MKUltra survivor is American Cathy O'Brien. I first met her and her late partner Mark Phillips at a conference in Colorado in 1996. Mark helped her escape and deprogram from decades of captivity in an offshoot of MKUltra known as Project Monarch in which 'sex slaves' were provided for the rich and famous including Father George Bush, Dick Cheney and the Clintons. Read Cathy and Mark's book *Trance-Formation of America* and if you are new to this you will be shocked to the core. I read it in 1996 shortly before, with the usual synchronicity of my life, I found

myself given a book table at the conference right next to hers. MKUltra never ended despite being very publicly exposed (only a small part of it) in the 1970s and continues in other guises. I am still in touch with Cathy. She contacted me during 2020 after masks became compulsory in many countries to tell me how they were used as part of MKUltra programming. I had been observing 'Covid regulations' and the relationship between authority and public for months. I saw techniques that I knew were employed on individuals in MKUltra being used on the global population. I had read many books and manuals on mind control including one called *Silent Weapons for Quiet Wars* which came to light in the 1980s and was a guide on how to perceptually program on a mass scale. 'Silent Weapons' refers to mind-control. I remembered a line from the manual as governments, medical authorities and law enforcement agencies have so obviously talked to – or rather at – the adult population since the 'Covid' hoax began as if they are children. The document said:

If a person is spoken to by a T.V. advertiser as if he were a twelve-year-old, then, due to suggestibility, he will, with a certain probability, respond or react to that suggestion with the uncritical response of a twelve-year-old and will reach in to his economic reservoir and deliver its energy to buy that product on impulse when he passes it in the store.

That's why authority has spoken to adults like children since all this began.

### **Why did Michael Jackson wear masks?**

Every aspect of the 'Covid' narrative has mind-control as its central theme. Cathy O'Brien wrote an article for [davidicke.com](http://davidicke.com) about the connection between masks and mind control. Her daughter Kelly who I first met in the 1990s was born while Cathy was still held captive in MKUltra. Kelly was forced to wear a mask as part of her programming from the age of *two* to dehumanise her, target her sense of individuality and reduce the amount of oxygen her brain and body received. *Bingo*. This is the real reason for compulsory

masks, why they have been enforced en masse, and why they seek to increase the number they demand you wear. First one, then two, with one disgraceful alleged 'doctor' recommending four which is nothing less than a death sentence. Where and how often they must be worn is being expanded for the purpose of mass mind control and damaging respiratory health which they can call 'Covid-19'. Canada's government headed by the man-child Justin Trudeau, says it's fine for children of two and older to wear masks. An insane 'study' in Italy involving just 47 children concluded there was no problem for babies as young as *four months* wearing them. Even after people were 'vaccinated' they were still told to wear masks by the criminal that is Anthony Fauci. Cathy wrote that mandating masks is allowing the authorities literally to control the air we breathe which is what was done in MKUltra. You might recall how the singer Michael Jackson wore masks and there is a reason for that. He was subjected to MKUltra mind control through Project Monarch and his psyche was scrambled by these simpletons. Cathy wrote:

In MKUltra Project Monarch mind control, Michael Jackson had to wear a mask to silence his voice so he could not reach out for help. Remember how he developed that whisper voice when he wasn't singing? Masks control the mind from the outside in, like the redefining of words is doing. By controlling what we can and cannot say for fear of being labeled racist or beaten, for example, it ultimately controls thought that drives our words and ultimately actions (or lack thereof).

Likewise, a mask muffles our speech so that we are not heard, which controls voice ... words ... mind. This is Mind Control. Masks are an obvious mind control device, and I am disturbed so many people are complying on a global scale. Masks depersonalize while making a person feel as though they have no voice. It is a barrier to others. People who would never choose to comply but are forced to wear a mask in order to keep their job, and ultimately their family fed, are compromised. They often feel shame and are subdued. People have stopped talking with each other while media controls the narrative.

The 'no voice' theme has often become literal with train passengers told not to speak to each other in case they pass on the 'virus', singing banned for the same reason and bonkers California officials telling people riding roller coasters that they cannot shout and scream. Cathy said she heard every day from healed MKUltra survivors who cannot wear a mask without flashing back on ways

their breathing was controlled – ‘from ball gags and penises to water boarding’. She said that through the years when she saw images of people in China wearing masks ‘due to pollution’ that it was really to control their oxygen levels. ‘I knew it was as much of a population control mechanism of depersonalisation as are burkas’, she said. Masks are another Chinese communist/fascist method of control that has been swept across the West as the West becomes China at lightning speed since we entered 2020.

## **Mask-19**

There are other reasons for mandatory masks and these include destroying respiratory health to call it ‘Covid-19’ and stunting brain development of children and the young. Dr Margarite Griesz-Brisson MD, PhD, is a Consultant Neurologist and Neurophysiologist and the Founder and Medical Director of the London Neurology and Pain Clinic. Her CV goes down the street and round the corner. She is clearly someone who cares about people and won’t parrot the propaganda. Griesz-Brisson has a PhD in pharmacology, with special interest in neurotoxicology, environmental medicine, neuroregeneration and neuroplasticity (the way the brain can change in the light of information received). She went public in October, 2020, with a passionate warning about the effects of mask-wearing laws:

The reinhalation of our exhaled air will without a doubt create oxygen deficiency and a flooding of carbon dioxide. We know that the human brain is very sensitive to oxygen deprivation. There are nerve cells for example in the hippocampus that can’t be longer than 3 minutes without oxygen – they cannot survive. The acute warning symptoms are headaches, drowsiness, dizziness, issues in concentration, slowing down of reaction time – reactions of the cognitive system.

Oh, I know, let’s tell bus, truck and taxi drivers to wear them and people working machinery. How about pilots, doctors and police? Griesz-Brisson makes the important point that while the symptoms she mentions may fade as the body readjusts this does not alter the fact that people continue to operate in oxygen deficit with long list of

potential consequences. She said it was well known that neurodegenerative diseases take years or decades to develop. 'If today you forget your phone number, the breakdown in your brain would have already started 20 or 30 years ago.' She said degenerative processes in your brain are getting amplified as your oxygen deprivation continues through wearing a mask. Nerve cells in the brain are unable to divide themselves normally in these circumstances and lost nerve cells will no longer be regenerated. 'What is gone is gone.' Now consider that people like shop workers and *schoolchildren* are wearing masks for hours every day. What in the name of sanity is going to be happening to them? 'I do not wear a mask, I need my brain to think', Griesz-Brisson said, 'I want to have a clear head when I deal with my patients and not be in a carbon dioxide-induced anaesthesia'. If you are told to wear a mask anywhere ask the organisation, police, store, whatever, for their risk assessment on the dangers and negative effects on mind and body of enforcing mask-wearing. They won't have one because it has never been done not even by government. All of them must be subject to class-action lawsuits as the consequences come to light. They don't do mask risk assessments for an obvious reason. They know what the conclusions would be and independent scientific studies that *have* been done tell a horror story of consequences.

### **'Masks are criminal'**

Dr Griesz-Brisson said that for children and adolescents, masks are an absolute no-no. They had an extremely active and adaptive immune system and their brain was incredibly active with so much to learn. 'The child's brain, or the youth's brain, is thirsting for oxygen.' The more metabolically active an organ was, the more oxygen it required; and in children and adolescents every organ was metabolically active. Griesz-Brisson said that to deprive a child's or adolescent's brain of oxygen, or to restrict it in any way, was not only dangerous to their health, it was absolutely criminal. 'Oxygen deficiency inhibits the development of the brain, and the damage that has taken place as a result CANNOT be reversed.' Mind

manipulators of MKUltra put masks on two-year-olds they wanted to neurologically rewire and you can see why. Griesz-Brisson said a child needs the brain to learn and the brain needs oxygen to function. 'We don't need a clinical study for that. This is simple, indisputable physiology.' Consciously and purposely induced oxygen deficiency was an absolutely deliberate health hazard, and an absolute medical contraindication which means that 'this drug, this therapy, this method or measure should not be used, and is not allowed to be used'. To coerce an entire population to use an absolute medical contraindication by force, she said, there had to be definite and serious reasons and the reasons must be presented to competent interdisciplinary and independent bodies to be verified and authorised. She had this warning of the consequences that were coming if mask wearing continued:

When, in ten years, dementia is going to increase exponentially, and the younger generations couldn't reach their god-given potential, it won't help to say 'we didn't need the masks'. I know how damaging oxygen deprivation is for the brain, cardiologists know how damaging it is for the heart, pulmonologists know how damaging it is for the lungs. Oxygen deprivation damages every single organ. Where are our health departments, our health insurance, our medical associations? It would have been their duty to be vehemently against the lockdown and to stop it and stop it from the very beginning.

Why do the medical boards issue punishments to doctors who give people exemptions? Does the person or the doctor seriously have to prove that oxygen deprivation harms people? What kind of medicine are our doctors and medical associations representing? Who is responsible for this crime? The ones who want to enforce it? The ones who let it happen and play along, or the ones who don't prevent it?

All of the organisations and people she mentions there either answer directly to the Cult or do whatever hierarchical levels above them tell them to do. The outcome of both is the same. 'It's not about masks, it's not about viruses, it's certainly not about your health', Griesz-Brisson said. 'It is about much, much more. I am not participating. I am not afraid.' They were taking our air to breathe and there was no unfounded medical exemption from face masks. Oxygen deprivation was dangerous for every single brain. It had to be the free decision of every human being whether they want to

wear a mask that was absolutely ineffective to protect themselves from a virus. She ended by rightly identifying where the responsibility lies for all this:

The imperative of the hour is personal responsibility. We are responsible for what we think, not the media. We are responsible for what we do, not our superiors. We are responsible for our health, not the World Health Organization. And we are responsible for what happens in our country, not the government.

Halle-bloody-lujah.

### **But surgeons wear masks, right?**

Independent studies of mask-wearing have produced a long list of reports detailing mental, emotional and physical dangers. What a definition of insanity to see police officers imposing mask-wearing on the public which will cumulatively damage their health while the police themselves wear masks that will cumulatively damage *their* health. It's utter madness and both public and police do this because 'the government says so' – yes a government of brain-donor idiots like UK Health Secretary Matt Hancock reading the 'follow the science' scripts of psychopathic, lunatic psychologists. The response you get from Stockholm syndrome sufferers defending the very authorities that are destroying them and their families is that 'surgeons wear masks'. This is considered the game, set and match that they must work and don't cause oxygen deficit. Well, actually, scientific studies have shown that they *do* and oxygen levels are monitored in operating theatres to compensate. Surgeons wear masks to stop spittle and such like dropping into open wounds – not to stop 'viral particles' which are so miniscule they can only be seen through an electron microscope. Holes in the masks are significantly bigger than 'viral particles' and if you sneeze or cough they will breach the mask. I watched an incredibly disingenuous 'experiment' that claimed to prove that masks work in catching 'virus' material from the mouth and nose. They did this with a slow motion camera and the mask did block big stuff which stayed inside the mask and



against the face to be breathed in or cause infections on the face as we have seen with many children. 'Viral particles', however, would never have been picked up by the camera as they came through the mask when they are far too small to be seen. The 'experiment' was therefore disingenuous *and* useless.

Studies have concluded that wearing masks in operating theatres (and thus elsewhere) make no difference to preventing infection while the opposite is true with toxic shite building up in the mask and this had led to an explosion in tooth decay and gum disease dubbed by dentists 'mask mouth'. You might have seen the Internet video of a furious American doctor urging people to take off their masks after a four-year-old patient had been rushed to hospital the night before and nearly died with a lung infection that doctors sourced to mask wearing. A study in the journal *Cancer Discovery* found that inhalation of harmful microbes can contribute to advanced stage lung cancer in adults and long-term use of masks can help breed dangerous pathogens. Microbiologists have said frequent mask wearing creates a moist environment in which microbes can grow and proliferate before entering the lungs. The Canadian Agency for Drugs and Technologies in Health, or CADTH, a Canadian national organisation that provides research and analysis to healthcare decision-makers, said this as long ago as 2013 in a report entitled 'Use of Surgical Masks in the Operating Room: A Review of the Clinical Effectiveness and Guidelines'. It said:

- No evidence was found to support the use of surgical face masks to reduce the frequency of surgical site infections
- No evidence was found on the effectiveness of wearing surgical face masks to protect staff from infectious material in the operating room.
- Guidelines recommend the use of surgical face masks by staff in the operating room to protect both operating room staff and patients (despite the lack of evidence).

We were told that the world could go back to 'normal' with the arrival of the 'vaccines'. When they came, fraudulent as they are, the story changed as I knew that it would. We are in the midst of transforming 'normal', not going back to it. Mary Ramsay, head of immunisation at Public Health England, echoed the words of US criminal Anthony Fauci who said masks and other regulations must stay no matter if people are vaccinated. The Fauci idiot continued to wear two masks – different colours so both could be clearly seen – after he *claimed* to have been vaccinated. Senator Rand Paul told Fauci in one exchange that his double-masks were 'theatre' and he was right. It's all theatre. Mary Ramsay back-tracked on the vaccine-return-to-normal theme when she said the public may need to wear masks and social-distance for years despite the jabs. 'People have got used to those lower-level restrictions now, and [they] can live with them', she said telling us what the idea has been all along. 'The vaccine does not give you a pass, even if you have had it, you must continue to follow all the guidelines' said a Public Health England statement which reneged on what we had been told before and made having the 'vaccine' irrelevant to 'normality' even by the official story. Spain's fascist government trumped everyone by passing a law mandating the wearing of masks on the beach and even when swimming in the sea. The move would have devastated what's left of the Spanish tourist industry, posed potential breathing dangers to swimmers and had Northern European sunbathers walking around with their forehead brown and the rest of their face white as a sheet. The ruling was so crazy that it had to be retracted after pressure from public and tourist industry, but it confirmed where the Cult wants to go with masks and how clinically insane authority has become. The determination to make masks permanent and hide the serious dangers to body and mind can be seen in the censorship of scientist Professor Denis Rancourt by Bill Gates-funded academic publishing website ResearchGate over his papers exposing the dangers and uselessness of masks. Rancourt said:

ResearchGate today has permanently locked my account, which I have had since 2015. Their reasons graphically show the nature of their attack against democracy, and their corruption of

science ... By their obscene non-logic, a scientific review of science articles reporting on harms caused by face masks has a 'potential to cause harm'. No criticism of the psychological device (face masks) is tolerated, if the said criticism shows potential to influence public policy.

This is what happens in a fascist world.

### **Where are the 'greens' (again)?**

Other dangers of wearing masks especially regularly relate to the inhalation of minute plastic fibres into the lungs and the deluge of discarded masks in the environment and oceans. Estimates predicted that more than 1.5 billion disposable masks will end up in the world's oceans every year polluting the water with tons of plastic and endangering marine wildlife. Studies project that humans are using 129 billion face masks each month worldwide – about three million a minute. Most are disposable and made from plastic, non-biodegradable microfibers that break down into smaller plastic particles that become widespread in ecosystems. They are littering cities, clogging sewage channels and turning up in bodies of water. I have written in other books about the immense amounts of microplastics from endless sources now being absorbed into the body. Rolf Halden, director of the Arizona State University (ASU) Biodesign Center for Environmental Health Engineering, was the senior researcher in a 2020 study that analysed 47 human tissue samples and found microplastics in all of them. 'We have detected these chemicals of plastics in every single organ that we have investigated', he said. I wrote in *The Answer* about the world being deluged with microplastics. A study by the Worldwide Fund for Nature (WWF) found that people are consuming on average every week some 2,000 tiny pieces of plastic mostly through water and also through marine life and the air. Every year humans are ingesting enough microplastics to fill a heaped dinner plate and in a life-time of 79 years it is enough to fill two large waste bins. Marco Lambertini, WWF International director general said: 'Not only are plastics polluting our oceans and waterways and killing marine life – it's in all of us and we can't escape consuming plastics,' American

geologists found tiny plastic fibres, beads and shards in rainwater samples collected from the remote slopes of the Rocky Mountain National Park near Denver, Colorado. Their report was headed: 'It is raining plastic.' Rachel Adams, senior lecturer in Biomedical Science at Cardiff Metropolitan University, said that among health consequences are internal inflammation and immune responses to a 'foreign body'. She further pointed out that microplastics become carriers of toxins including mercury, pesticides and dioxins (a known cause of cancer and reproductive and developmental problems). These toxins accumulate in the fatty tissues once they enter the body through microplastics. Now this is being compounded massively by people putting plastic on their face and throwing it away.

Workers exposed to polypropylene plastic fibres known as 'flock' have developed 'flock worker's lung' from inhaling small pieces of the flock fibres which can damage lung tissue, reduce breathing capacity and exacerbate other respiratory problems. *Now ...* commonly used surgical masks have three layers of melt-blown textiles made of ... polypropylene. We have billions of people putting these microplastics against their mouth, nose and face for hours at a time day after day in the form of masks. How does anyone think that will work out? I mean – what could possibly go wrong? We posted a number of scientific studies on this at [davidicke.com](http://davidicke.com), but when I went back to them as I was writing this book the links to the science research website where they were hosted were dead. Anything that challenges the official narrative in any way is either censored or vilified. The official narrative is so unsupportable by the evidence that only deleting the truth can protect it. A study by Chinese scientists still survived – with the usual twist which it why it was still active, I guess. Yes, they found that virtually all the masks they tested increased the daily intake of microplastic fibres, but people should still wear them because the danger from the 'virus' was worse said the crazy 'team' from the Institute of Hydrobiology in Wuhan. Scientists first discovered microplastics in lung tissue of some patients who died of lung cancer

in the 1990s. Subsequent studies have confirmed the potential health damage with the plastic degrading slowly and remaining in the lungs to accumulate in volume. Wuhan researchers used a machine simulating human breathing to establish that masks shed up to nearly 4,000 microplastic fibres in a month with reused masks producing more. Scientists said some masks are laced with toxic chemicals and a variety of compounds seriously restricted for both health and environmental reasons. They include cobalt (used in blue dye) and formaldehyde known to cause watery eyes, burning sensations in the eyes, nose, and throat, plus coughing, wheezing and nausea. No – that must be ‘Covid-19’.

### **Mask ‘worms’**

There is another and potentially even more sinister content of masks. Mostly new masks of different makes filmed under a microscope around the world have been found to contain strange black fibres or ‘worms’ that appear to move or ‘crawl’ by themselves and react to heat and water. The nearest I have seen to them are the self-replicating fibres that are pulled out through the skin of those suffering from Morgellons disease which has been connected to the phenomena of ‘chemtrails’ which I will bring into the story later on. Morgellons fibres continue to grow outside the body and have a form of artificial intelligence. Black ‘worm’ fibres in masks have that kind of feel to them and there is a nanotechnology technique called ‘worm micelles’ which carry and release drugs or anything else you want to deliver to the body. For sure the suppression of humanity by mind altering drugs is the Cult agenda big time and the more excuses they can find to gain access to the body the more opportunities there are to make that happen whether through ‘vaccines’ or masks pushed against the mouth and nose for hours on end.

So let us summarise the pros and cons of masks:

*Against masks:* Breathing in your own carbon dioxide; depriving the body and brain of sufficient oxygen; build-up of toxins in the mask that can be breathed into the lungs and cause rashes on the face and 'mask-mouth'; breathing microplastic fibres and toxic chemicals into the lungs; dehumanisation and deleting individualisation by literally making people faceless; destroying human emotional interaction through facial expression and deleting parental connection with their babies which look for guidance to their facial expression.

*For masks:* They don't protect you from a 'virus' that doesn't exist and even if it did 'viral' particles are so minute they are smaller than the holes in the mask.

Governments, police, supermarkets, businesses, transport companies, and all the rest who seek to impose masks have done no risk assessment on their consequences for health and psychology and are now open to group lawsuits when the impact becomes clear with a cumulative epidemic of respiratory and other disease. Authorities will try to exploit these effects and hide the real cause by dubbing them 'Covid-19'. Can you imagine setting out to force the population to wear health-destroying masks without doing any assessment of the risks? It is criminal and it is evil, but then how many people targeted in this way, who see their children told to wear them all day at school, have asked for a risk assessment? Billions can't be imposed upon by the few unless the billions allow it. Oh, yes, with just a tinge of irony, 85 percent of all masks made worldwide come from *China*.

### **Wash your hands in toxic shite**

'Covid' rules include the use of toxic sanitisers and again the health consequences of constantly applying toxins to be absorbed through the skin is obvious to any level of Renegade Mind. America's Food and Drug Administration (FDA) said that sanitisers are drugs and issued a warning about 75 dangerous brands which contain

methanol used in antifreeze and can cause death, kidney damage and blindness. The FDA circulated the following warning even for those brands that it claims to be safe:

Store hand sanitizer out of the reach of pets and children, and children should use it only with adult supervision. Do not drink hand sanitizer. This is particularly important for young children, especially toddlers, who may be attracted by the pleasant smell or brightly colored bottles of hand sanitizer.

Drinking even a small amount of hand sanitizer can cause alcohol poisoning in children. (However, there is no need to be concerned if your children eat with or lick their hands after using hand sanitizer.) During this coronavirus pandemic, poison control centers have had an increase in calls about accidental ingestion of hand sanitizer, so it is important that adults monitor young children's use.

Do not allow pets to swallow hand sanitizer. If you think your pet has eaten something potentially dangerous, call your veterinarian or a pet poison control center right away. Hand sanitizer is flammable and should be stored away from heat and flames. When using hand sanitizer, rub your hands until they feel completely dry before performing activities that may involve heat, sparks, static electricity, or open flames.

There you go, perfectly safe, then, and that's without even a mention of the toxins absorbed through the skin. Come on kids – sanitise your hands everywhere you go. It will save you from the 'virus'. Put all these elements together of the 'Covid' normal and see how much health and psychology is being cumulatively damaged, even devastated, to 'protect your health'. Makes sense, right? They are only imposing these things because they care, right? *Right?*

## **Submitting to insanity**

Psychological reframing of the population goes very deep and is done in many less obvious ways. I hear people say how contradictory and crazy 'Covid' rules are and how they are ever changing. This is explained away by dismissing those involved as idiots. It is a big mistake. The Cult is delighted if its cold calculation is perceived as incompetence and idiocy when it is anything but. Oh, yes, there are idiots within the system – lots of them – but they are *administering* the Cult agenda, mostly unknowingly. They are not deciding and dictating it. The bulwark against tyranny is self-

respect, always has been, always will be. It is self-respect that has broken every tyranny in history. By its very nature self-respect will not bow to oppression and its perpetrators. There is so little self-respect that it's always the few that overturn dictators. Many may eventually follow, but the few with the iron spines (self-respect) kick it off and generate the momentum. The Cult targets self-respect in the knowledge that once this has gone only submission remains. Crazy, contradictory, ever-changing 'Covid' rules are systematically applied by psychologists to delete self-respect. They *want* you to see that the rules make no sense. It is one thing to decide to do something when *you* have made the choice based on evidence and logic. You still retain your self-respect. It is quite another when you can see what you are being told to do is insane, ridiculous and makes no sense, and *yet you still do it*. Your self-respect is extinguished and this has been happening as ever more obviously stupid and nonsensical things have been demanded and the great majority have complied even when they can see they are stupid and nonsensical.

People walk around in face-nappies knowing they are damaging their health and make no difference to a 'virus'. They do it in fear of not doing it. I know it's daft, but I'll do it anyway. When that happens something dies inside of you and submissive reframing has begun. Next there's a need to hide from yourself that you have conceded your self-respect and you convince yourself that you have not really submitted to fear and intimidation. You begin to believe that you are complying with craziness because it's the right thing to do. When first you concede your self-respect of  $2+2 = 4$  to  $2+2 = 5$  you *know* you are compromising your self-respect. Gradually to avoid facing that fact you begin to *believe* that  $2+2=5$ . You have been reframed and I have been watching this process happening in the human psyche on an industrial scale. The Cult is working to break your spirit and one of its major tools in that war is humiliation. I read how former American soldier Bradley Manning (later Chelsea Manning after a sex-change) was treated after being jailed for supplying WikiLeaks with documents exposing the enormity of



government and elite mendacity. Manning was isolated in solitary confinement for eight months, put under 24-hour surveillance, forced to hand over clothing before going to bed, and stand naked for every roll call. This is systematic humiliation. The introduction of anal swab 'Covid' tests in China has been done for the same reason to delete self-respect and induce compliant submission. Anal swabs are mandatory for incoming passengers in parts of China and American diplomats have said they were forced to undergo the indignity which would have been calculated humiliation by the Cult-owned Chinese government that has America in its sights.

### **Government-people: An abusive relationship**

Spirit-breaking psychological techniques include giving people hope and apparent respite from tyranny only to take it away again. This happened in the UK during Christmas, 2020, when the psycho-psychologists and their political lackeys announced an easing of restrictions over the holiday only to reimpose them almost immediately on the basis of yet another lie. There is a big psychological difference between getting used to oppression and being given hope of relief only to have that dashed. Psychologists know this and we have seen the technique used repeatedly. Then there is traumatising people before you introduce more extreme regulations that require compliance. A perfect case was the announcement by the dark and sinister Whitty and Vallance in the UK that 'new data' predicted that 4,000 could die every day over the winter of 2020/2021 if we did not lockdown again. I think they call it lying and after traumatising people with that claim out came Jackboot Johnson the next day with new curbs on human freedom. Psychologists know that a frightened and traumatised mind becomes suggestable to submission and behaviour reframing. Underpinning all this has been to make people fearful and suspicious of each other and see themselves as a potential danger to others. In league with deleted self-respect you have the perfect psychological recipe for self-loathing. The relationship between authority and public is now demonstrably the same as that of

subservience to an abusive partner. These are signs of an abusive relationship explained by psychologist Leslie Becker-Phelps:

**Psychological and emotional abuse:** Undermining a partner's self-worth with verbal attacks, name-calling, and belittling. Humiliating the partner in public, unjustly accusing them of having an affair, or interrogating them about their every behavior. Keeping partner confused or off balance by saying they were just kidding or blaming the partner for 'making' them act this way ... Feigning in public that they care while turning against them in private. This leads to victims frequently feeling confused, incompetent, unworthy, hopeless, and chronically self-doubting. [Apply these techniques to how governments have treated the population since New Year, 2020, and the parallels are obvious.]

**Physical abuse:** The abuser might physically harm their partner in a range of ways, such as grabbing, hitting, punching, or shoving them. They might throw objects at them or harm them with a weapon. [Observe the physical harm imposed by masks, lockdown, and so on.]

**Threats and intimidation:** One way abusers keep their partners in line is by instilling fear. They might be verbally threatening, or give threatening looks or gestures. Abusers often make it known that they are tracking their partner's every move. They might destroy their partner's possessions, threaten to harm them, or threaten to harm their family members. Not surprisingly, victims of this abuse often feel anxiety, fear, and panic. [No words necessary.]

**Isolation:** Abusers often limit their partner's activities, forbidding them to talk or interact with friends or family. They might limit access to a car or even turn off their phone. All of this might be done by physically holding them against their will, but is often accomplished through psychological abuse and intimidation. The more isolated a person feels, the fewer resources they have to help gain perspective on their situation and to escape from it. [No words necessary.]

**Economic abuse:** Abusers often make their partners beholden to them for money by controlling access to funds of any kind. They might prevent their partner from getting a job or withhold access to money they earn from a job. This creates financial dependency that makes leaving the relationship very difficult. [See destruction of livelihoods and the proposed meagre 'guaranteed income' so long as you do whatever you are told.]

**Using children:** An abuser might disparage their partner's parenting skills, tell their children lies about their partner, threaten to take custody of their children, or threaten to harm their children. These tactics instil fear and often elicit compliance. [See reframed social service mafia and how children are being mercilessly abused by the state over 'Covid' while their parents look on too frightened to do anything.]

A further recurring trait in an abusive relationship is the abused blaming themselves for their abuse and making excuses for the abuser. We have the public blaming each other for lockdown abuse by government and many making excuses for the government while attacking those who challenge the government. How often we have heard authorities say that rules are being imposed or reimposed only because people have refused to 'behave' and follow the rules. We don't want to do it – it's *you*.

Renegade Minds are an antidote to all of these things. They will never concede their self-respect no matter what the circumstances. Even when apparent humiliation is heaped upon them they laugh in its face and reflect back the humiliation on the abuser where it belongs. Renegade Minds will never wear masks they know are only imposed to humiliate, suppress and damage both physically and psychologically. Consequences will take care of themselves and they will never break their spirit or cause them to concede to tyranny. UK newspaper columnist Peter Hitchens was one of the few in the mainstream media to speak out against lockdowns and forced vaccinations. He then announced he had taken the jab. He wanted to see family members abroad and he believed vaccine passports were inevitable even though they had not yet been introduced. Hitchens

has a questioning and critical mind, but not a Renegade one. If he had no amount of pressure would have made him concede. Hitchens excused his action by saying that the battle has been lost. Renegade Minds never accept defeat when freedom is at stake and even if they are the last one standing the self-respect of not submitting to tyranny is more important than any outcome or any consequence.

That's why Renegade Minds are the only minds that ever changed anything worth changing.

## CHAPTER EIGHT

### **'Reframing' insanity**

*Insanity is relative. It depends on who has who locked in what cage*  
Ray Bradbury

**R**eframing' a mind means simply to change its perception and behaviour. This can be done subconsciously to such an extent that subjects have no idea they have been 'reframed' while to any observer changes in behaviour and attitudes are obvious.

Human society is being reframed on a ginormous scale since the start of 2020 and here we have the reason why psychologists rather than doctors have been calling the shots. Ask most people who have succumbed to 'Covid' reframing if they have changed and most will say 'no'; but they *have* and fundamentally. The Cult's long-game has been preparing for these times since way back and crucial to that has been to prepare both population and officialdom mentally and emotionally. To use the mind-control parlance they had to reframe the population with a mentality that would submit to fascism and reframe those in government and law enforcement to impose fascism or at least go along with it. The result has been the fact-deleted mindlessness of 'Wokeness' and officialdom that has either enthusiastically or unquestioningly imposed global tyranny demanded by reframed politicians on behalf of psychopathic and deeply evil cultists. 'Cognitive reframing' identifies and challenges the way someone sees the world in the form of situations, experiences and emotions and then restructures those perceptions to view the same set of circumstances in a different way. This can have

benefits if the attitudes are personally destructive while on the other side it has the potential for individual and collective mind control which the subject has no idea has even happened.

Cognitive therapy was developed in the 1960s by Aaron T. Beck who was born in Rhode Island in 1921 as the son of Jewish immigrants from the Ukraine. He became interested in the techniques as a treatment for depression. Beck's daughter Judith S. Beck is prominent in the same field and they founded the Beck Institute for Cognitive Behavior Therapy in Philadelphia in 1994. Cognitive reframing, however, began to be used worldwide by those with a very dark agenda. The Cult reframes politicians to change their attitudes and actions until they are completely at odds with what they once appeared to stand for. The same has been happening to government administrators at all levels, law enforcement, military and the human population. Cultists love mind control for two main reasons: It allows them to control what people think, do and say to secure agenda advancement and, by definition, it calms their legendary insecurity and fear of the unexpected. I have studied mind control since the time I travelled America in 1996. I may have been talking to next to no one in terms of an audience in those years, but my goodness did I gather a phenomenal amount of information and knowledge about so many things including the techniques of mind control. I have described this in detail in other books going back to *The Biggest Secret* in 1998. I met a very large number of people recovering from MKUltra and its offshoots and successors and I began to see how these same techniques were being used on the population in general. This was never more obvious than since the 'Covid' hoax began.

## **Reframing the enforcers**

I have observed over the last two decades and more the very clear transformation in the dynamic between the police, officialdom and the public. I tracked this in the books as the relationship mutated from one of serving the public to seeing them as almost the enemy and certainly a lower caste. There has always been a class divide

based on income and always been some psychopathic, corrupt, and big-I-am police officers. This was different. Wholesale change was unfolding in the collective dynamic; it was less about money and far more about position and perceived power. An us-and-them was emerging. Noses were lifted skyward by government administration and law enforcement and their attitude to the public they were *supposed* to be serving changed to one of increasing contempt, superiority and control. The transformation was so clear and widespread that it had to be planned. Collective attitudes and dynamics do not change naturally and organically that quickly on that scale. I then came across an organisation in Britain called Common Purpose created in the late 1980s by Julia Middleton who would work in the office of Deputy Prime Minister John Prescott during the long and disastrous premiership of war criminal Tony Blair. When Blair speaks the Cult is speaking and the man should have been in jail a long time ago. Common Purpose proclaims itself to be one of the biggest 'leadership development' organisations in the world while functioning as a *charity* with all the financial benefits which come from that. It hosts 'leadership development' courses and programmes all over the world and claims to have 'brought together' what it calls 'leaders' from more than 100 countries on six continents. The modus operandi of Common Purpose can be compared with the work of the UK government's reframing network that includes the Behavioural Insights Team 'nudge unit' and 'Covid' reframing specialists at SPI-B. WikiLeaks described Common Purpose long ago as 'a hidden virus in our government and schools' which is unknown to the general public: 'It recruits and trains "leaders" to be loyal to the directives of Common Purpose and the EU, instead of to their own departments, which they then undermine or subvert, the NHS [National Health Service] being an example.' This is a vital point to understand the 'Covid' hoax. The NHS, and its equivalent around the world, has been utterly reframed in terms of administrators and much of the medical personnel with the transformation underpinned by recruitment policies. The outcome has been the criminal and psychopathic behaviour of the

NHS over 'Covid' and we have seen the same in every other major country. WikiLeaks said Common Purpose trainees are 'learning to rule without regard to democracy' and to usher in a police state (current events explained). Common Purpose operated like a 'glue' and had members in the NHS, BBC, police, legal profession, church, many of Britain's 7,000 quangos, local councils, the Civil Service, government ministries and Parliament, and controlled many RDA's (Regional Development Agencies). Here we have one answer for how and why British institutions and their like in other countries have changed so negatively in relation to the public. This further explains how and why the beyond-disgraceful reframed BBC has become a propaganda arm of 'Covid' fascism. They are all part of a network pursuing the same goal.

By 2019 Common Purpose was quoting a figure of 85,000 'leaders' that had attended its programmes. These 'students' of all ages are known as Common Purpose 'graduates' and they consist of government, state and local government officials and administrators, police chiefs and officers, and a whole range of others operating within the national, local and global establishment. Cressida Dick, Commissioner of the London Metropolitan Police, is the Common Purpose graduate who was the 'Gold Commander' that oversaw what can only be described as the murder of Brazilian electrician Jean Charles de Menezes in 2005. He was held down by psychopathic police and shot seven times in the head by a psychopathic lunatic after being mistaken for a terrorist when he was just a bloke going about his day. Dick authorised officers to pursue and keep surveillance on de Menezes and ordered that he be stopped from entering the underground train system. Police psychopaths took her at her word clearly. She was 'disciplined' for this outrage by being *promoted* – eventually to the top of the 'Met' police where she has been a disaster. Many Chief Constables controlling the police in different parts of the UK are and have been Common Purpose graduates. I have heard the 'graduate' network described as a sort of Mafia or secret society operating within the fabric of government at all levels pursuing a collective policy



ingrained at Common Purpose training events. Founder Julia Middleton herself has said:

Locally and internationally, Common Purpose graduates will be 'lighting small fires' to create change in their organisations and communities ... The Common Purpose effect is best illustrated by the many stories of small changes brought about by leaders, who themselves have changed.

A Common Purpose mission statement declared:

Common Purpose aims to improve the way society works by expanding the vision, decision-making ability and influence of all kinds of leaders. The organisation runs a variety of educational programmes for leaders of all ages, backgrounds and sectors, in order to provide them with the inspirational, information and opportunities they need to change the world.

Yes, but into what? Since 2020 the answer has become clear.

## **NLP and the Delphi technique**

Common Purpose would seem to be a perfect name or would common programming be better? One of the foundation methods of reaching 'consensus' (group think) is by setting the agenda theme and then encouraging, cajoling or pressuring everyone to agree a 'consensus' in line with the core theme promoted by Common Purpose. The methodology involves the 'Delphi technique', or an adaptation of it, in which opinions are expressed that are summarised by a 'facilitator or change agent' at each stage. Participants are 'encouraged' to modify their views in the light of what others have said. Stage by stage the former individual opinions are merged into group consensus which just happens to be what Common Purpose wants them to believe. A key part of this is to marginalise anyone refusing to concede to group think and turn the group against them to apply pressure to conform. We are seeing this very technique used on the general population to make 'Covid' group-thinkers hostile to those who have seen through the bullshit. People can be reframed by using perception manipulation methods such as Neuro-Linguistic Programming (NLP) in which you change perception with the use of

carefully constructed language. An NLP website described the technique this way:

... A method of influencing brain behaviour (the 'neuro' part of the phrase) through the use of language (the 'linguistic' part) and other types of communication to enable a person to 'recode' the way the brain responds to stimuli (that's the 'programming') and manifest new and better behaviours. Neuro-Linguistic Programming often incorporates hypnosis and self-hypnosis to help achieve the change (or 'programming') that is wanted.

British alternative media operation UKColumn has done very detailed research into Common Purpose over a long period. I quoted co-founder and former naval officer Brian Gerrish in my book *Remember Who You Are*, published in 2011, as saying the following years before current times:

It is interesting that many of the mothers who have had children taken by the State speak of the Social Services people being icily cool, emotionless and, as two ladies said in slightly different words, '... like little robots'. We know that NLP is cumulative, so people can be given small imperceptible doses of NLP in a course here, another in a few months, next year etc. In this way, major changes are accrued in their personality, but the day by day change is almost unnoticeable.

In these and other ways 'graduates' have had their perceptions uniformly reframed and they return to their roles in the institutions of government, law enforcement, legal profession, military, 'education', the UK National Health Service and the whole swathe of the establishment structure to pursue a common agenda preparing for the 'post-industrial', 'post-democratic' society. I say 'preparing' but we are now there. 'Post-industrial' is code for the Great Reset and 'post-democratic' is 'Covid' fascism. UKColumn has spoken to partners of those who have attended Common Purpose 'training'. They have described how personalities and attitudes of 'graduates' changed very noticeably for the worse by the time they had completed the course. They had been 'reframed' and told they are the 'leaders' – the special ones – who know better than the population. There has also been the very demonstrable recruitment of psychopaths and narcissists into government administration at all

levels and law enforcement. If you want psychopathy hire psychopaths and you get a simple cause and effect. If you want administrators, police officers and 'leaders' to perceive the public as lesser beings who don't matter then employ narcissists. These personalities are identified using 'psychometrics' that identifies knowledge, abilities, attitudes and personality traits, mostly through carefully-designed questionnaires and tests. As this policy has passed through the decades we have had power-crazy, power-trippers appointed into law enforcement, security and government administration in preparation for current times and the dynamic between public and law enforcement/officialdom has been transformed. UKColumn's Brian Gerrish said of the narcissistic personality:

Their love of themselves and power automatically means that they will crush others who get in their way. I received a major piece of the puzzle when a friend pointed out that when they made public officials re-apply for their own jobs several years ago they were also required to do psychometric tests. This was undoubtedly the start of the screening process to get 'their' sort of people in post.

How obvious that has been since 2020 although it was clear what was happening long before if people paid attention to the changing public-establishment dynamic.

## **Change agents**

At the centre of events in 'Covid' Britain is the National Health Service (NHS) which has behaved disgracefully in slavishly following the Cult agenda. The NHS management structure is awash with Common Purpose graduates or 'change agents' working to a common cause. Helen Bevan, a Chief of Service Transformation at the NHS Institute for Innovation and Improvement, co-authored a document called 'Towards a million change agents, a review of the social movements literature: implications for large scale change in the NHS'. The document compared a project management approach to that of change and social movements where 'people change

themselves and each other – peer to peer’. Two definitions given for a ‘social movement’ were:

*A group of people who consciously attempt to build a radically new social order; involves people of a broad range of social backgrounds; and deploys politically confrontational and socially disruptive tactics – Cyrus Zirakzadeh 1997*

*Collective challenges, based on common purposes and social solidarities, in sustained interaction with elites, opponents, and authorities – Sidney Tarrow 1994*

Helen Bevan wrote another NHS document in which she defined ‘framing’ as ‘the process by which leaders construct, articulate and put across their message in a powerful and compelling way in order to win people to their cause and call them to action’. I think I could come up with another definition that would be rather more accurate. The National Health Service and institutions of Britain and the wider world have been taken over by reframed ‘change agents’ and that includes everything from the United Nations to national governments, local councils and social services which have been kidnapping children from loving parents on an extraordinary and gathering scale on the road to the end of parenthood altogether. Children from loving homes are stolen and kidnapped by the state and put into the ‘care’ (inversion) of the local authority through council homes, foster parents and forced adoption. At the same time children are allowed to be abused without response while many are under council ‘care’. UKColumn highlighted the Common Purpose connection between South Yorkshire Police and Rotherham council officers in the case of the scandal in that area of the sexual exploitation of children to which the authorities turned not one blind eye, but both:

We were alarmed to discover that the Chief Executive, the Strategic Director of Children and Young People's Services, the Manager for the Local Strategic Partnership, the Community Cohesion Manager, the Cabinet Member for Cohesion, the Chief Constable and his predecessor had all attended Leadership training courses provided by the pseudo-charity Common Purpose.

Once 'change agents' have secured positions of hire and fire within any organisation things start to move very quickly. Personnel are then hired and fired on the basis of whether they will work towards the agenda the change agent represents. If they do they are rapidly promoted even though they may be incompetent. Those more qualified and skilled who are pre-Common Purpose 'old school' see their careers stall and even disappear. This has been happening for decades in every institution of state, police, 'health' and social services and all of them have been transformed as a result in their attitudes to their jobs and the public. Medical professions, including nursing, which were once vocations for the caring now employ many cold, callous and couldn't give a shit personality types. The UKColumn investigation concluded:

By blurring the boundaries between people, professions, public and private sectors, responsibility and accountability, Common Purpose encourages 'graduates' to believe that as new selected leaders, they can work together, outside of the established political and social structures, to achieve a paradigm shift or CHANGE – so called 'Leading Beyond Authority'. In doing so, the allegiance of the individual becomes 'reframed' on CP colleagues and their NETWORK.

## **Reframing the Face-Nappies**

Nowhere has this process been more obvious than in the police where recruitment of psychopaths and development of unquestioning mind-controlled group-thinkers have transformed law enforcement into a politically-correct 'Woke' joke and a travesty of what should be public service. Today they wear their face-nappies like good little gofers and enforce 'Covid' rules which are fascism under another name. Alongside the specifically-recruited psychopaths we have software minds incapable of free thought. Brian Gerrish again:

An example is the policeman who would not get on a bike for a press photo because he had not done the cycling proficiency course. Normal people say this is political correctness gone mad. Nothing could be further from the truth. The policeman has been reframed, and in his reality it is perfect common sense not to get on the bike 'because he hasn't done the cycling course'.

Another example of this is where the police would not rescue a boy from a pond until they had taken advice from above on the 'risk assessment'. A normal person would have arrived, perhaps thought of the risk for a moment, and dived in. To the police now 'reframed', they followed 'normal' procedure.

There are shocking cases of reframed ambulance crews doing the same. Sheer unthinking stupidity of London Face-Nappies headed by Common Purpose graduate Cressida Dick can be seen in their behaviour at a vigil in March, 2021, for a murdered woman, Sarah Everard. A police officer had been charged with the crime. Anyone with a brain would have left the vigil alone in the circumstances. Instead they 'manhandled' women to stop them breaking 'Covid rules' to betray classic reframing. Minds in the thrall of perception control have no capacity for seeing a situation on its merits and acting accordingly. 'Rules is rules' is their only mind-set. My father used to say that rules and regulations are for the guidance of the intelligent and the blind obedience of the idiot. Most of the intelligent, decent, coppers have gone leaving only the other kind and a few old school for whom the job must be a daily nightmare. The combination of psychopaths and rule-book software minds has been clearly on public display in the 'Covid' era with automaton robots in uniform imposing fascistic 'Covid' regulations on the population without any personal initiative or judging situations on their merits. There are thousands of examples around the world, but I'll make my point with the infamous Derbyshire police in the English East Midlands – the ones who think pouring dye into beauty spots and using drones to track people walking in the countryside away from anyone is called 'policing'. To them there are rules decreed by the government which they have to enforce and in their bewildered state a group gathering in a closed space and someone walking alone in the countryside are the same thing. It is beyond idiocy and enters the realm of clinical insanity.

Police officers in Derbyshire said they were 'horrified' – *horrified* – to find 15 to 20 'irresponsible' kids playing a football match at a closed leisure centre 'in breach of coronavirus restrictions'. When they saw the police the kids ran away leaving their belongings behind and the reframed men and women of Derbyshire police were seeking to establish their identities with a view to fining their parents. The most natural thing for youngsters to do – kicking a ball about – is turned into a criminal activity and enforced by the moronic software programs of Derbyshire police. You find the same mentality in every country. These barely conscious 'horrified' officers said they had to take action because 'we need to ensure these rules are being followed' and 'it is of the utmost importance that you ensure your children are following the rules and regulations for Covid-19'. Had any of them done ten seconds of research to see if this parroting of their masters' script could be supported by any evidence? Nope. Reframed people don't think – others think for them and that's the whole idea of reframing. I have seen police officers one after the other repeating without question word for word what officialdom tells them just as I have seen great swathes of the public doing the same. Ask either for 'their' opinion and out spews what they have been told to think by the official narrative. Police and public may seem to be in different groups, but their mentality is the same. Most people do whatever they are told in fear not doing so or because they believe what officialdom tells them; almost the entirety of the police do what they are told for the same reason. Ultimately it's the tiny inner core of the global Cult that's telling both what to do.

So Derbyshire police were 'horrified'. Oh, really? Why did they think those kids were playing football? It was to relieve the psychological consequences of lockdown and being denied human contact with their friends and interaction, touch and discourse vital to human psychological health. Being denied this month after month has dismantled the psyche of many children and young people as depression and suicide have exploded. Were Derbyshire police *horrified by that*? Are you kidding? Reframed people don't have those

mental and emotional processes that can see how the impact on the psychological health of youngsters is far more dangerous than any 'virus' even if you take the mendacious official figures to be true. The reframed are told (programmed) how to act and so they do. The Derbyshire Chief Constable in the first period of lockdown when the black dye and drones nonsense was going on was Peter Goodman. He was the man who severed the connection between his force and the Derbyshire Constabulary *Male Voice* Choir when he decided that it was not inclusive enough to allow women to join. The fact it was a male voice choir making a particular sound produced by male voices seemed to elude a guy who terrifyingly ran policing in Derbyshire. He retired weeks after his force was condemned as disgraceful by former Supreme Court Justice Jonathan Sumption for their behaviour over extreme lockdown impositions. Goodman was replaced by his deputy Rachel Swann who was in charge when her officers were 'horrified'. The police statement over the boys committing the hanging-offence of playing football included the line about the youngsters being 'irresponsible in the times we are all living through' missing the point that the real relevance of the 'times we are all living through' is the imposition of fascism enforced by psychopaths and reframed minds of police officers playing such a vital part in establishing the fascist tyranny that their own children and grandchildren will have to live in their entire lives. As a definition of insanity that is hard to beat although it might be run close by imposing masks on people that can have a serious effect on their health while wearing a face nappy all day themselves. Once again public and police do it for the same reason – the authorities tell them to and who are they to have the self-respect to say no?

## **Workers in uniform**

How reframed do you have to be to arrest a *six-year-old* and take him to court for *picking a flower* while waiting for a bus? Brain dead police and officialdom did just that in North Carolina where criminal proceedings happen regularly for children under nine. Attorney Julie Boyer gave the six-year-old crayons and a colouring book



during the 'flower' hearing while the 'adults' decided his fate. County Chief District Court Judge Jay Corpening asked: 'Should a child that believes in Santa Claus, the Easter Bunny and the tooth fairy be making life-altering decisions?' Well, of course not, but common sense has no meaning when you have a common purpose and a reframed mind. Treating children in this way, and police operating in American schools, is all part of the psychological preparation for children to accept a police state as normal all their adult lives. The same goes for all the cameras and biometric tracking technology in schools. Police training is focused on reframing them as snowflake Wokers and this is happening in the military. Pentagon top brass said that 'training sessions on extremism' were needed for troops who asked why they were so focused on the Capitol Building riot when Black Lives Matter riots were ignored. What's the difference between them some apparently and rightly asked. Actually, there is a difference. Five people died in the Capitol riot, only one through violence, and that was a police officer shooting an unarmed protestor. BLM riots killed at least 25 people and cost billions. Asking the question prompted the psychopaths and reframed minds that run the Pentagon to say that more 'education' (programming) was needed. Troop training is all based on psychological programming to make them fodder for the Cult – 'Military men are just dumb, stupid animals to be used as pawns in foreign policy' as Cult-to-his-DNA former Secretary of State Henry Kissinger famously said. Governments see the police in similar terms and it's time for those among them who can see this to defend the people and stop being enforcers of the Cult agenda upon the people.

The US military, like the country itself, is being targeted for destruction through a long list of Woke impositions. Cult-owned gaga 'President' Biden signed an executive order when he took office to allow taxpayer money to pay for transgender surgery for active military personnel and veterans. Are you a man soldier? No, I'm a LGBTQIA+ with a hint of Skoliosexual and Spectrasexual. Oh, good man. Bad choice of words you bigot. The Pentagon announced in March, 2021, the appointment of the first 'diversity and inclusion

officer' for US Special Forces. Richard Torres-Estrada arrived with the publication of a 'D&I Strategic Plan which will guide the enterprise-wide effort to institutionalize and sustain D&I'. If you think a Special Forces 'Strategic Plan' should have something to do with defending America you haven't been paying attention. Defending Woke is now the military's new role. Torres-Estrada has posted images comparing Donald Trump with Adolf Hitler and we can expect no bias from him as a representative of the supposedly non-political Pentagon. Cable news host Tucker Carlson said: 'The Pentagon is now the Yale faculty lounge but with cruise missiles.' Meanwhile Secretary of Defense Lloyd Austin, a board member of weapons-maker Raytheon with stock and compensation interests in October, 2020, worth \$1.4 million, said he was purging the military of the 'enemy within' – anyone who isn't Woke and supports Donald Trump. Austin refers to his targets as 'racist extremists' while in true Woke fashion being himself a racist extremist. Pentagon documents pledge to 'eradicate, eliminate and conquer all forms of racism, sexism and homophobia'. The definitions of these are decided by 'diversity and inclusion committees' peopled by those who see racism, sexism and homophobia in every situation and opinion. Woke (the Cult) is dismantling the US military and purging testosterone as China expands its military and gives its troops 'masculinity training'. How do we think that is going to end when this is all Cult coordinated? The US military, like the British military, is controlled by Woke and spineless top brass who just go along with it out of personal career interests.

### **'Woke' means fast asleep**

Mind control and perception manipulation techniques used on individuals to create group-think have been unleashed on the global population in general. As a result many have no capacity to see the obvious fascist agenda being installed all around them or what 'Covid' is really all about. Their brains are firewalled like a computer system not to process certain concepts, thoughts and realisations that are bad for the Cult. The young are most targeted as the adults they

will be when the whole fascist global state is planned to be fully implemented. They need to be prepared for total compliance to eliminate all pushback from entire generations. The Cult has been pouring billions into taking complete control of 'education' from schools to universities via its operatives and corporations and not least Bill Gates as always. The plan has been to transform 'education' institutions into programming centres for the mentality of 'Woke'. James McConnell, professor of psychology at the University of Michigan, wrote in *Psychology Today* in 1970:

The day has come when we can combine sensory deprivation with drugs, hypnosis, and astute manipulation of reward and punishment, to gain almost absolute control over an individual's behaviour. It should then be possible to achieve a very rapid and highly effective type of brainwashing that would allow us to make dramatic changes in a person's behaviour and personality ...

... We should reshape society so that we all would be trained from birth to want to do what society wants us to do. We have the techniques to do it... no-one owns his own personality you acquired, and there's no reason to believe you should have the right to refuse to acquire a new personality if your old one is anti-social.

This was the potential for mass brainwashing in 1970 and the mentality there displayed captures the arrogant psychopathy that drives it forward. I emphasise that not all young people have succumbed to Woke programming and those that haven't are incredibly impressive people given that today's young are the most perceptually-targeted generations in history with all the technology now involved. Vast swathes of the young generations, however, have fallen into the spell – and that's what it is – of Woke. The Woke mentality and perceptual program is founded on *inversion* and you will appreciate later why that is so significant. Everything with Woke is inverted and the opposite of what it is claimed to be. Woke was a term used in African-American culture from the 1900s and referred to an awareness of social and racial justice. This is not the meaning of the modern version or 'New Woke' as I call it in *The Answer*. Oh, no, Woke today means something very different no matter how much Wokers may seek to hide that and insist Old Woke and New

Woke are the same. See if you find any 'awareness of social justice' here in the modern variety:

- Woke demands 'inclusivity' while excluding anyone with a different opinion and calls for mass censorship to silence other views.
- Woke claims to stand against oppression when imposing oppression is the foundation of all that it does. It is the driver of political correctness which is nothing more than a Cult invention to manipulate the population to silence itself.
- Woke believes itself to be 'liberal' while pursuing a global society that can only be described as fascist (see 'anti-fascist' fascist Antifa).
- Woke calls for 'social justice' while spreading injustice wherever it goes against the common 'enemy' which can be easily identified as a differing view.
- Woke is supposed to be a metaphor for 'awake' when it is solid-gold asleep and deep in a Cult-induced coma that meets the criteria for 'off with the fairies'.

I state these points as obvious facts if people only care to look. I don't do this with a sense of condemnation. We need to appreciate that the onslaught of perceptual programming on the young has been incessant and merciless. I can understand why so many have been reframed, or, given their youth, framed from the start to see the world as the Cult demands. The Cult has had access to their minds day after day in its 'education' system for their entire formative years. Perception is formed from information received and the Cult-created system is a life-long download of information delivered to elicit a particular perception, thus behaviour. The more this has expanded into still new extremes in recent decades and ever-increasing censorship has deleted other opinions and information why wouldn't that lead to a perceptual reframing on a mass scale? I

have described already cradle-to-grave programming and in more recent times the targeting of young minds from birth to adulthood has entered the stratosphere. This has taken the form of skewing what is 'taught' to fit the Cult agenda and the omnipresent techniques of group-think to isolate non-believers and pressure them into line. There has always been a tendency to follow the herd, but we really are in a new world now in relation to that. We have parents who can see the 'Covid' hoax told by their children not to stop them wearing masks at school, being 'Covid' tested or having the 'vaccine' in fear of the peer-pressure consequences of being different. What is 'peer-pressure' if not pressure to conform to group-think? Renegade Minds never group-think and always retain a set of perceptions that are unique to them. Group-think is always underpinned by consequences for not group-thinking. Abuse now aimed at those refusing DNA-manipulating 'Covid vaccines' are a potent example of this. The biggest pressure to conform comes from the very group which is itself being manipulated. 'I am programmed to be part of a hive mind and so you must be.'

Woke control structures in 'education' now apply to every mainstream organisation. Those at the top of the 'education' hierarchy (the Cult) decide the policy. This is imposed on governments through the Cult network; governments impose it on schools, colleges and universities; their leadership impose the policy on teachers and academics and they impose it on children and students. At any level where there is resistance, perhaps from a teacher or university lecturer, they are targeted by the authorities and often fired. Students themselves regularly demand the dismissal of academics (increasingly few) at odds with the narrative that the students have been programmed to believe in. It is quite a thought that students who are being targeted by the Cult become so consumed by programmed group-think that they launch protests and demand the removal of those who are trying to push back against those targeting the students. Such is the scale of perceptual inversion. We see this with 'Covid' programming as the Cult imposes the rules via psycho-psychologists and governments on

shops, transport companies and businesses which impose them on their staff who impose them on their customers who pressure Pushbackers to conform to the will of the Cult which is in the process of destroying them and their families. Scan all aspects of society and you will see the same sequence every time.

### **Fact free Woke and hijacking the 'left'**

There is no more potent example of this than 'Woke', a mentality only made possible by the deletion of factual evidence by an 'education' system seeking to produce an ever more uniform society. Why would you bother with facts when you don't know any? Deletion of credible history both in volume and type is highly relevant. Orwell said: 'Who controls the past controls the future: who controls the present controls the past.' They who control the perception of the past control the perception of the future and they who control the present control the perception of the past through the writing and deleting of history. Why would you oppose the imposition of Marxism in the name of Wokeism when you don't know that Marxism cost at least 100 million lives in the 20th century alone? Watch videos and read reports in which Woker generations are asked basic historical questions – it's mind-blowing. A survey of 2,000 people found that six percent of millennials (born approximately early 1980s to early 2000s) believed the Second World War (1939-1945) broke out with the assassination of President Kennedy (in 1963) and one in ten thought Margaret Thatcher was British Prime Minister at the time. She was in office between 1979 and 1990. We are in a post-fact society. Provable facts are no defence against the fascism of political correctness or Silicon Valley censorship. Facts don't matter anymore as we have witnessed with the 'Covid' hoax. Sacrificing uniqueness to the Woke group-think religion is all you are required to do and that means thinking for yourself is the biggest Woke no, no. All religions are an expression of group-think and censorship and Woke is just another religion with an orthodoxy defended by group-think and censorship. Burned at

the stake becomes burned on Twitter which leads back eventually to burned at the stake as Woke humanity regresses to ages past.

The biggest Woke inversion of all is its creators and funders. I grew up in a traditional left of centre political household on a council estate in Leicester in the 1950s and 60s – you know, the left that challenged the power of wealth-hoarding elites and threats to freedom of speech and opinion. In those days students went on marches defending freedom of speech while today's Wokers march for its deletion. What on earth could have happened? Those very elites (collectively the Cult) that we opposed in my youth and early life have funded into existence the antithesis of that former left and hijacked the 'brand' while inverting everything it ever stood for. We have a mentality that calls itself 'liberal' and 'progressive' while acting like fascists. Cult billionaires and their corporations have funded themselves into control of 'education' to ensure that Woke programming is unceasing throughout the formative years of children and young people and that non-Wokers are isolated (that word again) whether they be students, teachers or college professors. The Cult has funded into existence the now colossal global network of Woke organisations that have spawned and promoted all the 'causes' on the Cult wish-list for global transformation and turned Wokers into demanders of them. Does anyone really think it's a coincidence that the Cult agenda for humanity is a carbon (sorry) copy of the societal transformations desired by Woke?? These are only some of them:

**Political correctness:** The means by which the Cult deletes all public debates that it knows it cannot win if we had the free-flow of information and evidence.

**Human-caused 'climate change':** The means by which the Cult seeks to transform society into a globally-controlled dictatorship imposing its will over the fine detail of everyone's lives 'to save the planet' which doesn't actually need saving.

**Transgender obsession:** Preparing collective perception to accept the 'new human' which would not have genders because it would be created technologically and not through procreation. I'll have much more on this in Human 2.0.

**Race obsession:** The means by which the Cult seeks to divide and rule the population by triggering racial division through the perception that society is more racist than ever when the opposite is the case. Is it perfect in that regard? No. But to compare today with the racism of apartheid and segregation brought to an end by the civil rights movement in the 1960s is to insult the memory of that movement and inspirations like Martin Luther King. Why is the 'anti-racism' industry (which it is) so dominated by privileged white people?

**White supremacy:** This is a label used by privileged white people to demonise poor and deprived white people pushing back on tyranny to marginalise and destroy them. White people are being especially targeted as the dominant race by number within Western society which the Cult seeks to transform in its image. If you want to change a society you must weaken and undermine its biggest group and once you have done that by using the other groups you next turn on them to do the same ... 'Then they came for the Jews and I was not a Jew so I did nothing.'

**Mass migration:** The mass movement of people from the Middle East, Africa and Asia into Europe, from the south into the United States and from Asia into Australia are another way the Cult seeks to dilute the racial, cultural and political influence of white people on Western society. White people ask why their governments appear to be working against them while being politically and culturally biased towards incoming cultures. Well, here's your answer. In the same way sexually 'straight' people, men and women, ask why the



authorities are biased against them in favour of other sexualities. The answer is the same – that’s the way the Cult wants it to be for very sinister motives.

These are all central parts of the Cult agenda and central parts of the Woke agenda and Woke was created and continues to be funded to an immense degree by Cult billionaires and corporations. If anyone begins to say ‘coincidence’ the syllables should stick in their throat.

### **Billionaire ‘social justice warriors’**

Joe Biden is a 100 percent-owned asset of the Cult and the Wokers’ man in the White House whenever he can remember his name and for however long he lasts with his rapidly diminishing cognitive function. Even walking up the steps of an aircraft without falling on his arse would appear to be a challenge. He’s not an empty-shell puppet or anything. From the minute Biden took office (or the Cult did) he began his executive orders promoting the Woke wish-list. You will see the Woke agenda imposed ever more severely because it’s really the *Cult* agenda. Woke organisations and activist networks spawned by the Cult are funded to the extreme so long as they promote what the Cult wants to happen. Woke is funded to promote ‘social justice’ by billionaires who become billionaires by destroying social justice. The social justice mantra is only a cover for dismantling social justice and funded by billionaires that couldn’t give a damn about social justice. Everything makes sense when you see that. One of Woke’s premier funders is Cult billionaire financier George Soros who said: ‘I am basically there to make money, I cannot and do not look at the social consequences of what I do.’ This is the same Soros who has given more than \$32 billion to his Open Society Foundations global Woke network and funded Black Lives Matter, mass immigration into Europe and the United States, transgender activism, climate change activism, political correctness and groups targeting ‘white supremacy’ in the form of privileged white thugs that dominate Antifa. What a scam it all is and when

you are dealing with the unquestioning fact-free zone of Woke scamming them is child's play. All you need to pull it off in all these organisations are a few in-the-know agents of the Cult and an army of naïve, reframed, uninformed, narcissistic, know-nothings convinced of their own self-righteousness, self-purity and virtue.

Soros and fellow billionaires and billionaire corporations have poured hundreds of millions into Black Lives Matter and connected groups and promoted them to a global audience. None of this is motivated by caring about black people. These are the billionaires that have controlled and exploited a system that leaves millions of black people in abject poverty and deprivation which they do absolutely nothing to address. The same Cult networks funding BLM were behind the *slave trade*! Black Lives Matter hijacked a phrase that few would challenge and they have turned this laudable concept into a political weapon to divide society. You know that BLM is a fraud when it claims that *All Lives Matter*, the most inclusive statement of all, is 'racist'. BLM and its Cult masters don't want to end racism. To them it's a means to an end to control all of humanity never mind the colour, creed, culture or background. What has destroying the nuclear family got to do with ending racism? Nothing – but that is one of the goals of BLM and also happens to be a goal of the Cult as I have been exposing in my books for decades. Stealing children from loving parents and giving schools ever more power to override parents is part of that same agenda. BLM is a Marxist organisation and why would that not be the case when the Cult created Marxism *and* BLM? Patrisse Cullors, a BLM co-founder, said in a 2015 video that she and her fellow organisers, including co-founder Alicia Garza, are 'trained Marxists'. The lady known after marriage as Patrisse Khan-Cullors bought a \$1.4 million home in 2021 in one of the whitest areas of California with a black population of just 1.6 per cent and has so far bought *four* high-end homes for a total of \$3.2 million. How very Marxist. There must be a bit of spare in the BLM coffers, however, when Cult corporations and billionaires have handed over the best part of \$100 million. Many black people can see that Black Lives Matter is not

working for them, but against them, and this is still more confirmation. Black journalist Jason Whitlock, who had his account suspended by Twitter for simply linking to the story about the 'Marxist's' home buying spree, said that BLM leaders are 'making millions of dollars off the backs of these dead black men who they wouldn't spit on if they were on fire and alive'.

## **Black Lies Matter**

Cult assets and agencies came together to promote BLM in the wake of the death of career criminal George Floyd who had been jailed a number of times including for forcing his way into the home of a black woman with others in a raid in which a gun was pointed at her stomach. Floyd was filmed being held in a Minneapolis street in 2020 with the knee of a police officer on his neck and he subsequently died. It was an appalling thing for the officer to do, but the same technique has been used by police on peaceful protestors of lockdown without any outcry from the Woke brigade. As unquestioning supporters of the Cult agenda Wokers have supported lockdown and all the 'Covid' claptrap while attacking anyone standing up to the tyranny imposed in its name. Court documents would later include details of an autopsy on Floyd by County Medical Examiner Dr Andrew Baker who concluded that Floyd had taken a fatal level of the drug fentanyl. None of this mattered to fact-free, question-free, Woke. Floyd's death was followed by worldwide protests against police brutality amid calls to defund the police. Throwing babies out with the bathwater is a Woke speciality. In the wake of the murder of British woman Sarah Everard a Green Party member of the House of Lords, Baroness Jones of Moulscroomb (Nincompoopia would have been better), called for a 6pm curfew for all men. This would be in breach of the Geneva Conventions on war crimes which ban collective punishment, but that would never have crossed the black and white Woke mind of Baroness Nincompoopia who would have been far too convinced of her own self-righteousness to compute such details. Many American cities did defund the police in the face of Floyd riots

and after \$15 million was deleted from the police budget in Washington DC under useless Woke mayor Muriel Bowser car-jacking alone rose by 300 percent and within six months the US capital recorded its highest murder rate in 15 years. The same happened in Chicago and other cities in line with the Cult/Soros plan to bring fear to streets and neighbourhoods by reducing the police, releasing violent criminals and not prosecuting crime. This is the mob-rule agenda that I have warned in the books was coming for so long. Shootings in the area of Minneapolis where Floyd was arrested increased by 2,500 percent compared with the year before. Defunding the police over George Floyd has led to a big increase in dead people with many of them black. Police protection for politicians making these decisions stayed the same or increased as you would expect from professional hypocrites. The Cult doesn't actually want to abolish the police. It wants to abolish local control over the police and hand it to federal government as the psychopaths advance the Hunger Games Society. Many George Floyd protests turned into violent riots with black stores and businesses destroyed by fire and looting across America fuelled by Black Lives Matter. Woke doesn't do irony. If you want civil rights you must loot the liquor store and the supermarket and make off with a smart TV. It's the only way.

### **It's not a race war – it's a class war**

Black people are patronised by privileged blacks and whites alike and told they are victims of white supremacy. I find it extraordinary to watch privileged blacks supporting the very system and bloodline networks behind the slave trade and parroting the same Cult-serving manipulative crap of their privileged white, often billionaire, associates. It is indeed not a race war but a class war and colour is just a diversion. Black Senator Cory Booker and black Congresswoman Maxine Waters, more residents of Nincompoopia, personify this. Once you tell people they are victims of someone else you devalue both their own responsibility for their plight and the power they have to impact on their reality and experience. Instead

we have: 'You are only in your situation because of whitey – turn on them and everything will change.' It won't change. Nothing changes in our lives unless *we* change it. Crucial to that is never seeing yourself as a victim and always as the creator of your reality. Life is a simple sequence of choice and consequence. Make different choices and you create different consequences. *You* have to make those choices – not Black Lives Matter, the Woke Mafia and anyone else that seeks to dictate your life. Who are they these Wokers, an emotional and psychological road traffic accident, to tell you what to do? Personal empowerment is the last thing the Cult and its Black Lives Matter want black people or anyone else to have. They claim to be defending the underdog while *creating* and perpetuating the underdog. The Cult's worst nightmare is human unity and if they are going to keep blacks, whites and every other race under economic servitude and control then the focus must be diverted from what they have in common to what they can be manipulated to believe divides them. Blacks have to be told that their poverty and plight is the fault of the white bloke living on the street in the same poverty and with the same plight they are experiencing. The difference is that your plight black people is due to him, a white supremacist with 'white privilege' living on the street. Don't unite as one human family against your mutual oppressors and suppressors – fight the oppressor with the white face who is as financially deprived as you are. The Cult knows that as its 'Covid' agenda moves into still new levels of extremism people are going to respond and it has been spreading the seeds of disunity everywhere to stop a united response to the evil that targets *all of us*.

Racist attacks on 'whiteness' are getting ever more outrageous and especially through the American Democratic Party which has an appalling history for anti-black racism. Barack Obama, Joe Biden, Hillary Clinton and Nancy Pelosi all eulogised about Senator Robert Byrd at his funeral in 2010 after a nearly 60-year career in Congress. Byrd was a brutal Ku Klux Klan racist and a violent abuser of Cathy O'Brien in MKUltra. He said he would never fight in the military 'with a negro by my side' and 'rather I should die a thousand times,

and see Old Glory trampled in the dirt never to rise again, than to see this beloved land of ours become degraded by race mongrels, a throwback to the blackest specimen from the wilds'. Biden called Byrd a 'very close friend and mentor'. These 'Woke' hypocrites are not anti-racist they are anti-poor and anti-people not of their perceived class. Here is an illustration of the scale of anti-white racism to which we have now descended. Seriously Woke and moronic *New York Times* contributor Damon Young described whiteness as a 'virus' that 'like other viruses will not die until there are no bodies left for it to infect'. He went on: '... the only way to stop it is to locate it, isolate it, extract it, and kill it.' Young can say that as a black man with no consequences when a white man saying the same in reverse would be facing a jail sentence. *That's* racism. We had super-Woke numbskull senators Tammy Duckworth and Mazie Hirono saying they would object to future Biden Cabinet appointments if he did not nominate more Asian Americans and Pacific Islanders. Never mind the ability of the candidate what do they look like? Duckworth said: 'I will vote for racial minorities and I will vote for LGBTQ, but anyone else I'm not voting for.' Appointing people on the grounds of race is illegal, but that was not a problem for this ludicrous pair. They were on-message and that's a free pass in any situation.

## **Critical race racism**

White children are told at school they are intrinsically racist as they are taught the divisive 'critical race theory'. This claims that the law and legal institutions are inherently racist and that race is a socially constructed concept used by white people to further their economic and political interests at the expense of people of colour. White is a 'virus' as we've seen. Racial inequality results from 'social, economic, and legal differences that white people create between races to maintain white interests which leads to poverty and criminality in minority communities'. I must tell that to the white guy sleeping on the street. The principal of East Side Community School in New York sent white parents a manifesto that called on

them to become 'white traitors' and advocate for full 'white abolition'. These people are teaching your kids when they urgently need a psychiatrist. The 'school' included a chart with 'eight white identities' that ranged from 'white supremacist' to 'white abolition' and defined the behaviour white people must follow to end 'the regime of whiteness'. Woke blacks and their privileged white associates are acting exactly like the slave owners of old and Ku Klux Klan racists like Robert Byrd. They are too full of their own self-purity to see that, but it's true. Racism is not a body type; it's a state of mind that can manifest through any colour, creed or culture.

Another racial fraud is '*equity*'. Not equality of treatment and opportunity – equity. It's a term spun as equality when it means something very different. Equality in its true sense is a raising up while '*equity*' is a race to the bottom. Everyone in the same level of poverty is '*equity*'. Keep everyone down – that's equity. The Cult doesn't want anyone in the human family to be empowered and BLM leaders, like all these 'anti-racist' organisations, continue their privileged, pampered existence by perpetuating the perception of gathering racism. When is the last time you heard an 'anti-racist' or 'anti-Semitism' organisation say that acts of racism and discrimination have *fallen*? It's not in the interests of their fundraising and power to influence and the same goes for the professional soccer anti-racism operation, Kick It Out. Two things confirmed that the Black Lives Matter riots in the summer of 2020 were Cult creations. One was that while anti-lockdown protests were condemned in this same period for 'transmitting 'Covid' the authorities supported mass gatherings of Black Lives Matter supporters. I even saw self-deluding people claiming to be doctors say the two types of protest were not the same. No – the non-existent 'Covid' was in favour of lockdowns and attacked those that protested against them while 'Covid' supported Black Lives Matter and kept well away from its protests. The whole thing was a joke and as lockdown protestors were arrested, often brutally, by reframed Face-Nappies we had the grotesque sight of police officers taking the knee to Black Lives Matter, a Cult-funded Marxist

organisation that supports violent riots and wants to destroy the nuclear family and white people.

## **He's not white? Shucks!**

Woke obsession with race was on display again when ten people were shot dead in Boulder, Colorado, in March, 2021. Cult-owned Woke TV channels like CNN said the shooter appeared to be a white man and Wokers were on Twitter condemning 'violent white men' with the usual mantras. Then the shooter's name was released as Ahmad Al Aliwi Alissa, an anti-Trump Arab-American, and the sigh of disappointment could be heard five miles away. Never mind that ten people were dead and what that meant for their families. Race baiting was all that mattered to these sick Cult-serving people like Barack Obama who exploited the deaths to further divide America on racial grounds which is his job for the Cult. This is the man that 'racist' white Americans made the first black president of the United States and then gave him a second term. Not-very-bright Obama has become filthy rich on the back of that and today appears to have a big influence on the Biden administration. Even so he's still a downtrodden black man and a victim of white supremacy. This disingenuous fraud reveals the contempt he has for black people when he puts on a Deep South Alabama accent whenever he talks to them, no, *at* them.

Another BLM red flag was how the now fully-Woke (fully-Cult) and fully-virtue-signalled professional soccer authorities had their teams taking the knee before every match in support of Marxist Black Lives Matter. Soccer authorities and clubs displayed 'Black Lives Matter' on the players' shirts and flashed the name on electronic billboards around the pitch. Any fans that condemned what is a Freemasonic taking-the-knee ritual were widely condemned as you would expect from the Woke virtue-signallers of professional sport and the now fully-Woke media. We have reverse racism in which you are banned from criticising any race or culture except for white people for whom anything goes – say what you like, no problem. What has this got to do with racial harmony and



equality? We've had black supremacists from Black Lives Matter telling white people to fall to their knees in the street and apologise for their white supremacy. Black supremacists acting like white supremacist slave owners of the past couldn't breach their self-obsessed, race-obsessed sense of self-purity. Joe Biden appointed a race-obsessed black supremacist Kristen Clarke to head the Justice Department Civil Rights Division. Clarke claimed that blacks are endowed with 'greater mental, physical and spiritual abilities' than whites. If anyone reversed that statement they would be vilified. Clarke is on-message so no problem. She's never seen a black-white situation in which the black figure is anything but a virtuous victim and she heads the Civil Rights Division which should treat everyone the same or it isn't civil rights. Another perception of the Renegade Mind: If something or someone is part of the Cult agenda they will be supported by Woke governments and media no matter what. If they're not, they will be condemned and censored. It really is that simple and so racist Clarke prospers despite (make that because of) her racism.

## **The end of culture**

Biden's administration is full of such racial, cultural and economic bias as the Cult requires the human family to be divided into warring factions. We are now seeing racially-segregated graduations and everything, but everything, is defined through the lens of perceived 'racism'. We have 'racist' mathematics, 'racist' food and even 'racist' *plants*. World famous Kew Gardens in London said it was changing labels on plants and flowers to tell its pre-'Covid' more than two million visitors a year how racist they are. Kew director Richard Deverell said this was part of an effort to 'move quickly to decolonise collections' after they were approached by one Ajay Chhabra 'an actor with an insight into how sugar cane was linked to slavery'. They are *plants* you idiots. 'Decolonisation' in the Woke manual really means colonisation of society with its mentality and by extension colonisation by the Cult. We are witnessing a new Chinese-style 'Cultural Revolution' so essential to the success of all

Marxist takeovers. Our cultural past and traditions have to be swept away to allow a new culture to be built-back-better. Woke targeting of long-standing Western cultural pillars including historical monuments and cancelling of historical figures is what happened in the Mao revolution in China which 'purged remnants of capitalist and traditional elements from Chinese society' and installed Maoism as the dominant ideology'. For China see the Western world today and for 'dominant ideology' see Woke. Better still see Marxism or Maoism. The 'Covid' hoax has specifically sought to destroy the arts and all elements of Western culture from people meeting in a pub or restaurant to closing theatres, music venues, sports stadiums, places of worship and even banning *singing*. Destruction of Western society is also why criticism of any religion is banned except for Christianity which again is the dominant religion as white is the numerically-dominant race. Christianity may be fading rapidly, but its history and traditions are weaved through the fabric of Western society. Delete the pillars and other structures will follow until the whole thing collapses. I am not a Christian defending that religion when I say that. I have no religion. It's just a fact. To this end Christianity has itself been turned Woke to usher its own downfall and its ranks are awash with 'change agents' – knowing and unknowing – at every level including Pope Francis (*definitely* knowing) and the clueless Archbishop of Canterbury Justin Welby (possibly not, but who can be sure?). Woke seeks to coordinate attacks on Western culture, traditions, and ways of life through 'intersectionality' defined as 'the complex, cumulative way in which the effects of multiple forms of discrimination (such as racism, sexism, and classism) combine, overlap, or intersect especially in the experiences of marginalised individuals or groups'. Wade through the Orwellian Woke-speak and this means coordinating disparate groups in a common cause to overthrow freedom and liberal values.

The entire structure of public institutions has been infested with Woke – government at all levels, political parties, police, military, schools, universities, advertising, media and trade unions. This abomination has been achieved through the Cult web by appointing

Wokers to positions of power and battering non-Wokers into line through intimidation, isolation and threats to their job. Many have been fired in the wake of the empathy-deleted, vicious hostility of 'social justice' Wokers and the desire of gutless, spineless employers to virtue-signal their Wokeness. Corporations are filled with Wokers today, most notably those in Silicon Valley. Ironically at the top they are not Woke at all. They are only exploiting the mentality their Cult masters have created and funded to censor and enslave while the Wokers cheer them on until it's their turn. Thus the Woke 'liberal left' is an inversion of the traditional liberal left. Campaigning for justice on the grounds of power and wealth distribution has been replaced by campaigning for identity politics. The genuine traditional left would never have taken money from today's billionaire abusers of fairness and justice and nor would the billionaires have wanted to fund that genuine left. It would not have been in their interests to do so. The division of opinion in those days was between the haves and have nots. This all changed with Cult manipulated and funded identity politics. The division of opinion today is between Wokers and non-Wokers and not income brackets. Cult corporations and their billionaires may have taken wealth disparity to cataclysmic levels of injustice, but as long as they speak the language of Woke, hand out the dosh to the Woke network and censor the enemy they are 'one of us'. Billionaires who don't give a damn about injustice are laughing at them till their bellies hurt. Wokers are not even close to self-aware enough to see that. The transformed 'left' dynamic means that Wokers who drone on about 'social justice' are funded by billionaires that have destroyed social justice the world over. It's *why* they are billionaires.

## **The climate con**

Nothing encapsulates what I have said more comprehensively than the hoax of human-caused global warming. I have detailed in my books over the years how Cult operatives and organisations were the pump-primers from the start of the climate con. A purpose-built vehicle for this is the Club of Rome established by the Cult in 1968

with the Rockefellers and Rothschilds centrally involved all along. Their gofer frontman Maurice Strong, a Canadian oil millionaire, hosted the Earth Summit in Rio de Janeiro, Brazil, in 1992 where the global 'green movement' really expanded in earnest under the guiding hand of the Cult. The Earth Summit established Agenda 21 through the Cult-created-and-owned United Nations to use the illusion of human-caused climate change to justify the transformation of global society to save the world from climate disaster. It is a No-Problem-Reaction-Solution sold through governments, media, schools and universities as whole generations have been terrified into believing that the world was going to end in their lifetimes unless what old people had inflicted upon them was stopped by a complete restructuring of how everything is done. Chill, kids, it's all a hoax. Such restructuring is precisely what the Cult agenda demands (purely by coincidence of course). Today this has been given the codename of the Great Reset which is only an updated term for Agenda 21 and its associated Agenda 2030. The latter, too, is administered through the UN and was voted into being by the General Assembly in 2015. Both 21 and 2030 seek centralised control of all resources and food right down to the raindrops falling on your own land. These are some of the demands of Agenda 21 established in 1992. See if you recognise this society emerging today:

- End national sovereignty
- State planning and management of all land resources, ecosystems, deserts, forests, mountains, oceans and fresh water; agriculture; rural development; biotechnology; and ensuring 'equity'
- The state to 'define the role' of business and financial resources
- Abolition of private property
- 'Restructuring' the family unit (see BLM)
- Children raised by the state
- People told what their job will be
- Major restrictions on movement
- Creation of 'human settlement zones'

- Mass resettlement as people are forced to vacate land where they live
- Dumbing down education
- Mass global depopulation in pursuit of all the above

The United Nations was created as a Trojan horse for world government. With the climate con of critical importance to promoting that outcome you would expect the UN to be involved. Oh, it's involved all right. The UN is promoting Agenda 21 and Agenda 2030 justified by 'climate change' while also driving the climate hoax through its Intergovernmental Panel on Climate Change (IPCC), one of the world's most corrupt organisations. The IPCC has been lying ferociously and constantly since the day it opened its doors with the global media hanging unquestioningly on its every mendacious word. The Green movement is entirely Woke and has long lost its original environmental focus since it was co-opted by the Cult. An obsession with 'global warming' has deleted its values and scrambled its head. I experienced a small example of what I mean on a beautiful country walk that I have enjoyed several times a week for many years. The path merged into the fields and forests and you felt at one with the natural world. Then a 'Green' organisation, the Hampshire and Isle of Wight Wildlife Trust, took over part of the land and proceeded to cut down a large number of trees, including mature ones, to install a horrible big, bright steel 'this-is-ours-stay-out' fence that destroyed the whole atmosphere of this beautiful place. No one with a feel for nature would do that. Day after day I walked to the sound of chainsaws and a magnificent mature weeping willow tree that I so admired was cut down at the base of the trunk. When I challenged a Woke young girl in a green shirt (of course) about this vandalism she replied: 'It's a weeping willow – it will grow back.' This is what people are paying for when they donate to the Hampshire and Isle of Wight Wildlife Trust and many other 'green' organisations today. It is not the environmental movement that I knew and instead has become a support-system – as with Extinction Rebellion – for a very dark agenda.

## **Private jets for climate justice**

The Cult-owned, Gates-funded, World Economic Forum and its founder Klaus Schwab were behind the emergence of Greta Thunberg to harness the young behind the climate agenda and she was invited to speak to the world at ... the UN. Schwab published a book, *Covid-19: The Great Reset* in 2020 in which he used the 'Covid' hoax and the climate hoax to lay out a new society straight out of Agenda 21 and Agenda 2030. Bill Gates followed in early 2021 when he took time out from destroying the world to produce a book in his name about the way to save it. Gates flies across the world in private jets and admitted that 'I probably have one of the highest greenhouse gas footprints of anyone on the planet ... my personal flying alone is gigantic.' He has also bid for the planet's biggest private jet operator. Other climate change saviours who fly in private jets include John Kerry, the US Special Presidential Envoy for Climate, and actor Leonardo DiCaprio, a 'UN Messenger of Peace with special focus on climate change'. These people are so full of bullshit they could corner the market in manure. We mustn't be sceptical, though, because the Gates book, *How to Avoid a Climate Disaster: The Solutions We Have and the Breakthroughs We Need*, is a genuine attempt to protect the world and not an obvious pile of excrement attributed to a mega-psychopath aimed at selling his masters' plans for humanity. The Gates book and the other shite-pile by Klaus Schwab could have been written by the same person and may well have been. Both use 'climate change' and 'Covid' as the excuses for their new society and by coincidence the Cult's World Economic Forum and Bill and Melinda Gates Foundation promote the climate hoax and hosted Event 201 which pre-empted with a 'simulation' the very 'coronavirus' hoax that would be simulated for real on humanity within weeks. The British 'royal' family is promoting the 'Reset' as you would expect through Prince 'climate change caused the war in Syria' Charles and his hapless son Prince William who said that we must 'reset our relationship with nature and our trajectory as a species' to avoid a climate disaster. Amazing how many promoters of the 'Covid' and 'climate change' control

systems are connected to Gates and the World Economic Forum. A 'study' in early 2021 claimed that carbon dioxide emissions must fall by the equivalent of a global lockdown roughly every two years for the next decade to save the planet. The 'study' appeared in the same period that the Schwab mob claimed in a video that lockdowns destroying the lives of billions are good because they make the earth 'quieter' with less 'ambient noise'. They took down the video amid a public backlash for such arrogant, empathy-deleted stupidity You see, however, where they are going with this. Corinne Le Quéré, a professor at the Tyndall Centre for Climate Change Research, University of East Anglia, was lead author of the climate lockdown study, and she writes for ... the World Economic Forum. Gates calls in 'his' book for changing 'every aspect of the economy' (long-time Cult agenda) and for humans to eat synthetic 'meat' (predicted in my books) while cows and other farm animals are eliminated. Australian TV host and commentator Alan Jones described what carbon emission targets would mean for farm animals in Australia alone if emissions were reduced as demanded by 35 percent by 2030 and zero by 2050:

Well, let's take agriculture, the total emissions from agriculture are about 75 million tonnes of carbon dioxide, equivalent. Now reduce that by 35 percent and you have to come down to 50 million tonnes, I've done the maths. So if you take for example 1.5 million cows, you're going to have to reduce the herd by 525,000 [by] 2030, nine years, that's 58,000 cows a year. The beef herd's 30 million, reduce that by 35 percent, that's 10.5 million, which means 1.2 million cattle have to go every year between now and 2030. This is insanity!

There are 75 million sheep. Reduce that by 35 percent, that's 26 million sheep, that's almost 3 million a year. So under the Paris Agreement over 30 million beasts. dairy cows, cattle, pigs and sheep would go. More than 8,000 every minute of every hour for the next decade, do these people know what they're talking about?

Clearly they don't at the level of campaigners, politicians and administrators. The Cult *does* know; that's the outcome it wants. We are faced with not just a war on humanity. Animals and the natural world are being targeted and I have been saying since the 'Covid' hoax began that the plan eventually was to claim that the 'deadly virus' is able to jump from animals, including farm animals and

domestic pets, to humans. Just before this book went into production came this story: 'Russia registers world's first Covid-19 vaccine for cats & dogs as makers of Sputnik V warn pets & farm animals could spread virus'. The report said 'top scientists warned that the deadly pathogen could soon begin spreading through homes and farms' and 'the next stage is the infection of farm and domestic animals'. Know the outcome and you'll see the journey. Think what that would mean for animals and keep your eye on a term called zoonosis or zoonotic diseases which transmit between animals and humans. The Cult wants to break the connection between animals and people as it does between people and people. Farm animals fit with the Cult agenda to transform food from natural to synthetic.

### **The gas of life is killing us**

There can be few greater examples of Cult inversion than the condemnation of carbon dioxide as a dangerous pollutant when it is the gas of life. Without it the natural world would be dead and so we would all be dead. We breathe in oxygen and breathe out carbon dioxide while plants produce oxygen and absorb carbon dioxide. It is a perfect symbiotic relationship that the Cult wants to dismantle for reasons I will come to in the final two chapters. Gates, Schwab, other Cult operatives and mindless repeaters, want the world to be 'carbon neutral' by at least 2050 and the earlier the better. 'Zero carbon' is the cry echoed by lunatics calling for 'Zero Covid' when we already have it. These carbon emission targets will deindustrialise the world in accordance with Cult plans – the post-industrial, post-democratic society – and with so-called renewables like solar and wind not coming even close to meeting human energy needs blackouts and cold are inevitable. Texans got the picture in the winter of 2021 when a snow storm stopped wind turbines and solar panels from working and the lights went down along with water which relies on electricity for its supply system. Gates wants everything to be powered by electricity to ensure that his masters have the kill switch to stop all human activity, movement, cooking, water and warmth any time they like. The climate lie is so



stupendously inverted that it claims we must urgently reduce carbon dioxide when we *don't have enough*.

Co2 in the atmosphere is a little above 400 parts per million when the optimum for plant growth is 2,000 ppm and when it falls anywhere near 150 ppm the natural world starts to die and so do we. It fell to as low as 280 ppm in an 1880 measurement in Hawaii and rose to 413 ppm in 2019 with industrialisation which is why the planet has become *greener* in the industrial period. How insane then that psychopathic madman Gates is not satisfied only with blocking the rise of Co2. He's funding technology to suck it out of the atmosphere. The reason why will become clear. The industrial era is not destroying the world through Co2 and has instead turned around a potentially disastrous ongoing fall in Co2. Greenpeace co-founder and scientist Patrick Moore walked away from Greenpeace in 1986 and has exposed the green movement for fear-mongering and lies. He said that 500 million years ago there was *17 times* more Co2 in the atmosphere than we have today and levels have been falling for hundreds of millions of years. In the last 150 million years Co2 levels in Earth's atmosphere had reduced by *90 percent*. Moore said that by the time humanity began to unlock carbon dioxide from fossil fuels we were at '38 seconds to midnight' and in that sense: 'Humans are [the Earth's] salvation.' Moore made the point that only half the Co2 emitted by fossil fuels stays in the atmosphere and we should remember that all pollution pouring from chimneys that we are told is carbon dioxide is in fact nothing of the kind. It's pollution. Carbon dioxide is an invisible gas.

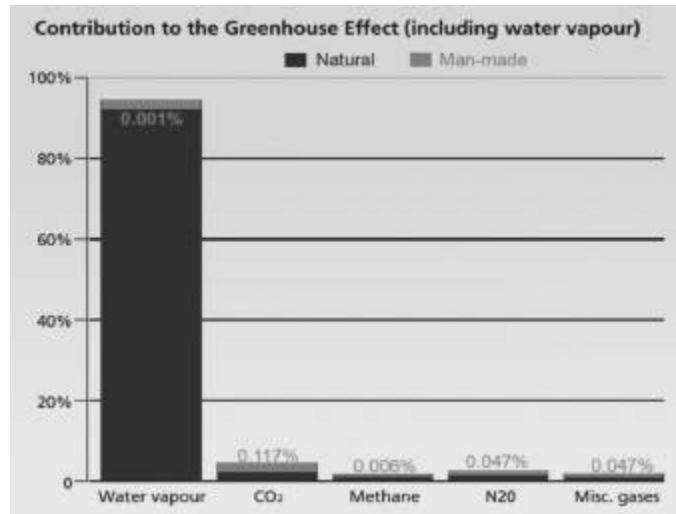
William Happer, Professor of Physics at Princeton University and long-time government adviser on climate, has emphasised the Co2 deficiency for maximum growth and food production. Greenhouse growers don't add carbon dioxide for a bit of fun. He said that most of the warming in the last 100 years, after the earth emerged from the super-cold period of the 'Little Ice Age' into a natural warming cycle, was over by 1940. Happer said that a peak year for warming in 1988 can be explained by a 'monster El Nino' which is a natural and cyclical warming of the Pacific that has nothing to do with 'climate

change'. He said the effect of Co2 could be compared to painting a wall with red paint in that once two or three coats have been applied it didn't matter how much more you slapped on because the wall will not get much redder. Almost all the effect of the rise in Co2 has already happened, he said, and the volume in the atmosphere would now have to *double* to increase temperature by a single degree. Climate hoaxers know this and they have invented the most ridiculously complicated series of 'feedback' loops to try to overcome this rather devastating fact. You hear puppet Greta going on cluelessly about feedback loops and this is why.

### **The Sun affects temperature? No you *climate denier***

Some other nonsense to contemplate: Climate graphs show that rises in temperature do not follow rises in Co2 – *it's the other way round* with a lag between the two of some 800 years. If we go back 800 years from present time we hit the Medieval Warm Period when temperatures were higher than now without any industrialisation and this was followed by the Little Ice Age when temperatures plummeted. The world was still emerging from these centuries of serious cold when many climate records began which makes the ever-repeated line of the 'hottest year since records began' meaningless when you are not comparing like with like. The coldest period of the Little Ice Age corresponded with the lowest period of sunspot activity when the Sun was at its least active. Proper scientists will not be at all surprised by this when it confirms the obvious fact that earth temperature is affected by the scale of Sun activity and the energetic power that it subsequently emits; but when is the last time you heard a climate hoaxer talking about the Sun as a source of earth temperature?? Everything has to be focussed on Co2 which makes up just 0.117 percent of so-called greenhouse gases and only a fraction of even that is generated by human activity. The rest is natural. More than *90 percent* of those greenhouse gases are water vapour and clouds ([Fig 9](#)). Ban moisture I say. Have you noticed that the climate hoaxers no longer use the polar bear as their promotion image? That's because far from becoming extinct polar

bear communities are stable or thriving. Joe Bastardi, American meteorologist, weather forecaster and outspoken critic of the climate lie, documents in his book *The Climate Chronicles* how weather patterns and events claimed to be evidence of climate change have been happening since long before industrialisation: 'What happened before naturally is happening again, as is to be expected given the cyclical nature of the climate due to the design of the planet.' If you read the detailed background to the climate hoax in my other books you will shake your head and wonder how anyone could believe the crap which has spawned a multi-trillion dollar industry based on absolute garbage (see HIV causes AIDs and Sars-Cov-2 causes 'Covid-19'). Climate and 'Covid' have much in common given they have the same source. They both have the contradictory *everything* factor in which everything is explained by reference to them. It's hot – 'it's climate change'. It's cold – 'it's climate change'. I got a sniffle – 'it's Covid'. I haven't got a sniffle – 'it's Covid'. Not having a sniffle has to be a symptom of 'Covid'. Everything is and not having a sniffle is especially dangerous if you are a slow walker. For sheer audacity I offer you a Cambridge University 'study' that actually linked 'Covid' to 'climate change'. It had to happen eventually. They concluded that climate change played a role in 'Covid-19' spreading from animals to humans because ... wait for it ... I kid you not ... *the two groups were forced closer together as populations grow*. Er, that's it. The whole foundation on which this depended was that 'Bats are the likely zoonotic origin of SARS-CoV-1 and SARS-CoV-2'. Well, they are not. They are nothing to do with it. Apart from bats not being the origin and therefore 'climate change' effects on bats being irrelevant I am in awe of their academic insight. Where would we be without them? Not where we are that's for sure.



**Figure 9:** The idea that the gas of life is disastrously changing the climate is an insult to brain cell activity.

One other point about the weather is that climate modification is now well advanced and not every major weather event is natural – or earthquake come to that. I cover this subject at some length in other books. China is openly planning a rapid expansion of its weather modification programme which includes changing the climate in an area more than one and a half times the size of India. China used weather manipulation to ensure clear skies during the 2008 Olympics in Beijing. I have quoted from US military documents detailing how to employ weather manipulation as a weapon of war and they did that in the 1960s and 70s during the conflict in Vietnam with Operation Popeye manipulating monsoon rains for military purposes. Why would there be international treaties on weather modification if it wasn't possible? Of course it is. Weather is energetic information and it can be changed.

### **How was the climate hoax pulled off? See 'Covid'**

If you can get billions to believe in a 'virus' that doesn't exist you can get them to believe in human-caused climate change that doesn't exist. Both are being used by the Cult to transform global society in the way it has long planned. Both hoaxes have been achieved in pretty much the same way. First you declare a lie is a fact. There's a

'virus' you call SARS-Cov-2 or humans are warming the planet with their behaviour. Next this becomes, via Cult networks, the foundation of government, academic and science policy and belief. Those who parrot the mantra are given big grants to produce research that confirms the narrative is true and ever more 'symptoms' are added to make the 'virus'/'climate change' sound even more scary. Scientists and researchers who challenge the narrative have their grants withdrawn and their careers destroyed. The media promote the lie as the unquestionable truth and censor those with an alternative view or evidence. A great percentage of the population believe what they are told as the lie becomes an everybody-knows-that and the believing-masses turn on those with a mind of their own. The technique has been used endlessly throughout human history. Wokers are the biggest promoters of the climate lie *and* 'Covid' fascism because their minds are owned by the Cult; their sense of self-righteous self-purity knows no bounds; and they exist in a bubble of reality in which facts are irrelevant and only get in the way of looking without seeing.

Running through all of this like veins in a blue cheese is control of information, which means control of perception, which means control of behaviour, which collectively means control of human society. The Cult owns the global media and Silicon Valley fascists for the simple reason that it *has* to. Without control of information it can't control perception and through that human society. Examine every facet of the Cult agenda and you will see that anything supporting its introduction is never censored while anything pushing back is always censored. I say again: Psychopaths that know why they are doing this must go before Nuremberg trials and those that follow their orders must trot along behind them into the same dock. 'I was just following orders' didn't work the first time and it must not work now. Nuremberg trials must be held all over the world before public juries for politicians, government officials, police, compliant doctors, scientists and virologists, and all Cult operatives such as Gates, Tedros, Fauci, Vallance, Whitty, Ferguson, Zuckerberg, Wojcicki, Brin, Page, Dorsey, the whole damn lot of

them – including, no *especially*, the psychopath psychologists. Without them and the brainless, gutless excuses for journalists that have repeated their lies, none of this could be happening. Nobody can be allowed to escape justice for the psychological and economic Armageddon they are all responsible for visiting upon the human race.

As for the compliant, unquestioning, swathes of humanity, and the self-obsessed, all-knowing ignorance of the Wokers ... don't start me. God help their kids. God help their grandkids. God *help them*.

## CHAPTER NINE

### **We must have it? So what is it?**

*Well I won't back down. No, I won't back down. You can stand me up at the Gates of Hell. But I won't back down*

**Tom Petty**

I will now focus on the genetically-manipulating 'Covid vaccines' which do not meet this official definition of a vaccine by the US Centers for Disease Control (CDC): 'A product that stimulates a person's immune system to produce immunity to a specific disease, protecting the person from that disease.' On that basis 'Covid vaccines' are not a vaccine in that the makers don't even claim they stop infection or transmission.

They are instead part of a multi-levelled conspiracy to change the nature of the human body and what it means to be 'human' and to depopulate an enormous swathe of humanity. What I shall call Human 1.0 is on the cusp of becoming Human 2.0 and for very sinister reasons. Before I get to the 'Covid vaccine' in detail here's some background to vaccines in general. Government regulators do not test vaccines – the makers do – and the makers control which data is revealed and which isn't. Children in America are given 50 vaccine doses by age six and 69 by age 19 and the effect of the whole combined schedule has never been tested. Autoimmune diseases when the immune system attacks its own body have soared in the mass vaccine era and so has disease in general in children and the young. Why wouldn't this be the case when vaccines target the *immune system*? The US government gave Big Pharma drug

companies immunity from prosecution for vaccine death and injury in the 1986 National Childhood Vaccine Injury Act (NCVIA) and since then the government (taxpayer) has been funding compensation for the consequences of Big Pharma vaccines. The criminal and satanic drug giants can't lose and the vaccine schedule has increased dramatically since 1986 for this reason. There is no incentive to make vaccines safe and a big incentive to make money by introducing ever more. Even against a ridiculously high bar to prove vaccine liability, and with the government controlling the hearing in which it is being challenged for compensation, the vaccine court has so far paid out more than \$4 billion. These are the vaccines we are told are safe and psychopaths like Zuckerberg censor posts saying otherwise. The immunity law was even justified by a ruling that vaccines by their nature were 'unavoidably unsafe'.

Check out the ingredients of vaccines and you will be shocked if you are new to this. *They put that in children's bodies?? What??* Try aluminium, a brain toxin connected to dementia, aborted foetal tissue and formaldehyde which is used to embalm corpses. World-renowned aluminium expert Christopher Exley had his research into the health effect of aluminium in vaccines shut down by Keele University in the UK when it began taking funding from the Bill and Melinda Gates Foundation. Research when diseases 'eradicated' by vaccines began to decline and you will find the fall began long *before* the vaccine was introduced. Sometimes the fall even plateaued after the vaccine. Diseases like scarlet fever for which there was no vaccine declined in the same way because of environmental and other factors. A perfect case in point is the polio vaccine. Polio began when lead arsenate was first sprayed as an insecticide and residues remained in food products. Spraying started in 1892 and the first US polio epidemic came in Vermont in 1894. The simple answer was to stop spraying, but Rockefeller-created Big Pharma had a better idea. Polio was decreed to be caused by the *poliovirus* which 'spreads from person to person and can infect a person's spinal cord'. Lead arsenate was replaced by the lethal DDT which had the same effect of causing paralysis by damaging the brain and central nervous



system. Polio plummeted when DDT was reduced and then banned, but the vaccine is still given the credit for something it didn't do. Today by far the biggest cause of polio is the vaccines promoted by Bill Gates. Vaccine justice campaigner Robert Kennedy Jr, son of assassinated (by the Cult) US Attorney General Robert Kennedy, wrote:

In 2017, the World Health Organization (WHO) reluctantly admitted that the global explosion in polio is predominantly vaccine strain. The most frightening epidemics in Congo, Afghanistan, and the Philippines, are all linked to vaccines. In fact, by 2018, 70% of global polio cases were vaccine strain.

Vaccines make fortunes for Cult-owned Gates and Big Pharma while undermining the health and immune systems of the population. We had a glimpse of the mentality behind the Big Pharma cartel with a report on WION (World is One News), an international English language TV station based in India, which exposed the extraordinary behaviour of US drug company Pfizer over its 'Covid vaccine'. The WION report told how Pfizer had made fantastic demands of Argentina, Brazil and other countries in return for its 'vaccine'. These included immunity from prosecution, even for Pfizer negligence, government insurance to protect Pfizer from law suits and handing over as collateral sovereign assets of the country to include Argentina's bank reserves, military bases and embassy buildings. Pfizer demanded the same of Brazil in the form of waiving sovereignty of its assets abroad; exempting Pfizer from Brazilian laws; and giving Pfizer immunity from all civil liability. This is a 'vaccine' developed with government funding. Big Pharma is evil incarnate as a creation of the Cult and all must be handed tickets to Nuremberg.

### **Phantom 'vaccine' for a phantom 'disease'**

I'll expose the 'Covid vaccine' fraud and then go on to the wider background of why the Cult has set out to 'vaccinate' every man, woman and child on the planet for an alleged 'new disease' with a survival rate of 99.77 percent (or more) even by the grotesquely-

manipulated figures of the World Health Organization and Johns Hopkins University. The 'infection' to 'death' ratio is 0.23 to 0.15 percent according to Stanford epidemiologist Dr John Ioannidis and while estimates vary the danger remains tiny. I say that if the truth be told the fake infection to fake death ratio is zero. Never mind all the evidence I have presented here and in *The Answer* that there is no 'virus' let us just focus for a moment on that death-rate figure of say 0.23 percent. The figure includes all those worldwide who have tested positive with a test not testing for the 'virus' and then died within 28 days or even longer of any other cause – *any other cause*. Now subtract all those illusory 'Covid' deaths on the global data sheets from the 0.23 percent. What do you think you would be left with? *Zero*. A vaccination has never been successfully developed for a so-called coronavirus. They have all failed at the animal testing stage when they caused hypersensitivity to what they were claiming to protect against and made the impact of a disease far worse. Cult-owned vaccine corporations got around that problem this time by bypassing animal trials, going straight to humans and making the length of the 'trials' before the public rollout as short as they could get away with. Normally it takes five to ten years or more to develop vaccines that still cause demonstrable harm to many people and that's without including the long-term effects that are never officially connected to the vaccination. 'Covid' non-vaccines have been officially produced and approved in a matter of months from a standing start and part of the reason is that (a) they were developed before the 'Covid' hoax began and (b) they are based on computer programs and not natural sources. Official non-trials were so short that government agencies gave *emergency*, not full, approval. 'Trials' were not even completed and full approval cannot be secured until they are. Public 'Covid vaccination' is actually a *continuation of the trial*. Drug company 'trials' are not scheduled to end until 2023 by which time a lot of people are going to be dead. Data on which government agencies gave this emergency approval was supplied by the Big Pharma corporations themselves in the form of Pfizer/BioNTech, AstraZeneca, Moderna, Johnson & Johnson, and

others, and this is the case with all vaccines. By its very nature *emergency* approval means drug companies do not have to prove that the 'vaccine' is 'safe and effective'. How could they with trials way short of complete? Government regulators only have to *believe* that they *could* be safe and effective. It is criminal manipulation to get products in circulation with no testing worth the name. Agencies giving that approval are infested with Big Pharma-connected place-people and they act in the interests of Big Pharma (the Cult) and not the public about whom they do not give a damn.

### **More human lab rats**

'Covid vaccines' produced in record time by Pfizer/BioNTech and Moderna employ a technique *never approved before for use on humans*. They are known as mRNA 'vaccines' and inject a synthetic version of 'viral' mRNA or 'messenger RNA'. The key is in the term 'messenger'. The body works, or doesn't, on the basis of information messaging. Communications are constantly passing between and within the genetic system and the brain. Change those messages and you change the state of the body and even its very nature and you can change psychology and behaviour by the way the brain processes information. I think you are going to see significant changes in personality and perception of many people who have had the 'Covid vaccine' synthetic potions. Insider Aldous Huxley predicted the following in 1961 and mRNA 'vaccines' can be included in the term 'pharmacological methods':

There will be, in the next generation or so, a pharmacological method of making people love their servitude, and producing dictatorship without tears, so to speak, producing a kind of painless concentration camp for entire societies, so that people will in fact have their own liberties taken away from them, but rather enjoy it, because they will be distracted from any desire to rebel by propaganda or brainwashing, or brainwashing enhanced by pharmacological methods. And this seems to be the final revolution.

Apologists claim that mRNA synthetic 'vaccines' don't change the DNA genetic blueprint because RNA does not affect DNA only the other way round. This is so disingenuous. A process called 'reverse

transcription' can convert RNA into DNA and be integrated into DNA in the cell nucleus. This was highlighted in December, 2020, by scientists at Harvard and Massachusetts Institute of Technology (MIT). Geneticists report that more than 40 percent of mammalian genomes results from reverse transcription. On the most basic level if messaging changes then that sequence must lead to changes in DNA which is receiving and transmitting those communications. How can introducing synthetic material into cells not change the cells where DNA is located? The process is known as transfection which is defined as 'a technique to insert foreign nucleic acid (DNA or RNA) into a cell, typically with the intention of altering the properties of the cell'. Researchers at the Sloan Kettering Institute in New York found that changes in messenger RNA can deactivate tumour-suppressing proteins and thereby promote cancer. This is what happens when you mess with messaging. 'Covid vaccine' maker Moderna was founded in 2010 by Canadian stem cell biologist Derrick J. Rossi after his breakthrough discovery in the field of transforming and reprogramming stem cells. These are neutral cells that can be programmed to become any cell including sperm cells. Moderna was therefore founded on the principle of genetic manipulation and has never produced any vaccine or drug before its genetically-manipulating synthetic 'Covid' shite. Look at the name – Mode-RNA or Modify-RNA. Another important point is that the US Supreme Court has ruled that genetically-modified DNA, or complementary DNA (cDNA) synthesized in the laboratory from messenger RNA, can be patented and owned. These psychopaths are doing this to the human body.

Cells replicate synthetic mRNA in the 'Covid vaccines' and in theory the body is tricked into making antigens which trigger antibodies to target the 'virus spike proteins' which as Dr Tom Cowan said have *never been seen*. Cut the crap and these 'vaccines' deliver *self-replicating* synthetic material to the cells with the effect of changing human DNA. The more of them you have the more that process is compounded while synthetic material is all the time self-replicating. 'Vaccine'-maker Moderna describes mRNA as 'like

software for the cell' and so they are messing with the body's software. What happens when you change the software in a computer? Everything changes. For this reason the Cult is preparing a production line of mRNA 'Covid vaccines' and a long list of excuses to use them as with all the 'variants' of a 'virus' never shown to exist. The plan is further to transfer the mRNA technique to other vaccines mostly given to children and young people. The cumulative consequences will be a transformation of human DNA through a constant infusion of synthetic genetic material which will kill many and change the rest. Now consider that governments that have given emergency approval for a vaccine that's not a vaccine; never been approved for humans before; had no testing worth the name; and the makers have been given immunity from prosecution for any deaths or adverse effects suffered by the public. The UK government awarded *permanent legal indemnity* to itself and its employees for harm done when a patient is being treated for 'Covid-19' or 'suspected Covid-19'. That is quite a thought when these are possible 'side-effects' from the 'vaccine' (they are not 'side', they are effects) listed by the US Food and Drug Administration:

Guillain-Barre syndrome; acute disseminated encephalomyelitis; transverse myelitis; encephalitis; myelitis; encephalomyelitis; meningoencephalitis; meningitis; encephalopathy; convulsions; seizures; stroke; narcolepsy; cataplexy; anaphylaxis; acute myocardial infarction (heart attack); myocarditis; pericarditis; autoimmune disease; death; implications for pregnancy, and birth outcomes; other acute demyelinating diseases; non anaphylactic allergy reactions; thrombocytopenia ; disseminated intravascular coagulation; venous thromboembolism; arthritis; arthralgia; joint pain; Kawasaki disease; multisystem inflammatory syndrome in children; vaccine enhanced disease. The latter is the way the 'vaccine' has the potential to make diseases far worse than they would otherwise be.

UK doctor and freedom campaigner Vernon Coleman described the conditions in this list as 'all unpleasant, most of them very serious, and you can't get more serious than death'. The thought that anyone at all has had the 'vaccine' in these circumstances is testament to the potential that humanity has for clueless, unquestioning, stupidity and for many that programmed stupidity has already been terminal.

## **An insider speaks**

Dr Michael Yeadon is a former Vice President, head of research and Chief Scientific Adviser at vaccine giant Pfizer. Yeadon worked on the inside of Big Pharma, but that did not stop him becoming a vocal critic of 'Covid vaccines' and their potential for multiple harms, including infertility in women. By the spring of 2021 he went much further and even used the no, no, term 'conspiracy'. When you begin to see what is going on it is impossible not to do so. Yeadon spoke out in an interview with freedom campaigner James Delingpole and I mentioned earlier how he said that no one had samples of 'the virus'. He explained that the mRNA technique originated in the anti-cancer field and ways to turn on and off certain genes which could be advantageous if you wanted to stop cancer growing out of control. 'That's the origin of them. They are a very unusual application, really.' Yeadon said that treating a cancer patient with an aggressive procedure might be understandable if the alternative was dying, but it was quite another thing to use the same technique as a public health measure. Most people involved wouldn't catch the infectious agent you were vaccinating against and if they did they probably wouldn't die:

If you are really using it as a public health measure you really want to as close as you can get to zero sides-effects ... I find it odd that they chose techniques that were really cutting their teeth in the field of oncology and I'm worried that in using gene-based vaccines that have to be injected in the body and spread around the body, get taken up into some cells, and the regulators haven't quite told us which cells they get taken up into ... you are going to be generating a wide range of responses ... with multiple steps each of which could go well or badly.

I doubt the Cult intends it to go well. Yeadon said that you can put any gene you like into the body through the 'vaccine'. 'You can certainly give them a gene that would do them some harm if you wanted.' I was intrigued when he said that when used in the cancer field the technique could turn genes on and off. I explore this process in *The Answer* and with different genes having different functions you could create mayhem – physically and psychologically – if you turned the wrong ones on and the right ones off. I read reports of an experiment by researchers at the University of Washington's school of computer science and engineering in which they encoded DNA to infect computers. The body is itself a biological computer and if human DNA can inflict damage on a computer why can't the computer via synthetic material mess with the human body? It can. The Washington research team said it was possible to insert malicious malware into 'physical DNA strands' and corrupt the computer system of a gene sequencing machine as it 'reads gene letters and stores them as binary digits 0 and 1'. They concluded that hackers could one day use blood or spit samples to access computer systems and obtain sensitive data from police forensics labs or infect genome files. It is at this level of digital interaction that synthetic 'vaccines' need to be seen to get the full picture and that will become very clear later on. Michael Yeadon said it made no sense to give the 'vaccine' to younger people who were in no danger from the 'virus'. What was the benefit? It was all downside with potential effects:

The fact that my government in what I thought was a civilised, rational country, is raining [the 'vaccine'] on people in their 30s and 40s, even my children in their 20s, they're getting letters and phone calls, I know this is not right and any of you doctors who are vaccinating you know it's not right, too. They are not at risk. They are not at risk from the disease, so you are now hoping that the side-effects are so rare that you get away with it. You don't give new technology ... that you don't understand to 100 percent of the population.

Blood clot problems with the AstraZeneca 'vaccine' have been affecting younger people to emphasise the downside risks with no benefit. AstraZeneca's version, produced with Oxford University, does not use mRNA, but still gets its toxic cocktail inside cells where

it targets DNA. The Johnson & Johnson 'vaccine' which uses a similar technique has also produced blood clot effects to such an extent that the United States paused its use at one point. They are all 'gene therapy' (cell modification) procedures and not 'vaccines'. The truth is that once the content of these injections enter cells we have no idea what the effect will be. People can speculate and some can give very educated opinions and that's good. In the end, though, only the makers know what their potions are designed to do and even they won't know every last consequence. Michael Yeadon was scathing about doctors doing what they knew to be wrong. 'Everyone's mute', he said. Doctors in the NHS must know this was not right, coming into work and injecting people. 'I don't know how they sleep at night. I know I couldn't do it. I know that if I were in that position I'd have to quit.' He said he knew enough about toxicology to know this was not a good risk-benefit. Yeadon had spoken to seven or eight university professors and all except two would not speak out publicly. Their universities had a policy that no one said anything that countered the government and its medical advisors. They were afraid of losing their government grants. This is how intimidation has been used to silence the truth at every level of the system. I say silence, but these people could still speak out if they made that choice. Yeadon called them 'moral cowards' – 'This is about your children and grandchildren's lives and you have just buggered off and left it.'

### **'Variant' nonsense**

Some of his most powerful comments related to the alleged 'variants' being used to instil more fear, justify more lockdowns, and introduce more 'vaccines'. He said government claims about 'variants' were nonsense. He had checked the alleged variant 'codes' and they were 99.7 percent identical to the 'original'. This was the human identity difference equivalent to putting a baseball cap on and off or wearing it the other way round. A 0.3 percent difference would make it impossible for that 'variant' to escape immunity from the 'original'. This made no sense of having new 'vaccines' for



'variants'. He said there would have to be at least a *30 percent* difference for that to be justified and even then he believed the immune system would still recognise what it was. Gates-funded 'variant modeller' and 'vaccine'-pusher John Edmunds might care to comment. Yeadon said drug companies were making new versions of the 'vaccine' as a 'top up' for 'variants'. Worse than that, he said, the 'regulators' around the world like the MHRA in the UK had got together and agreed that because 'vaccines' for 'variants' were so similar to the first 'vaccines' *they did not have to do safety studies*. How transparently sinister that is. This is when Yeadon said: 'There is a conspiracy here.' There was no need for another vaccine for 'variants' and yet we were told that there was and the country had shut its borders because of them. 'They are going into hundreds of millions of arms without passing 'go' or any regulator. Why did they do that? Why did they pick this method of making the vaccine?'

The reason had to be something bigger than that it seemed and 'it's not protection against the virus'. It's was a far bigger project that meant politicians and advisers were willing to do things and not do things that knowingly resulted in avoidable deaths – 'that's already happened when you think about lockdown and deprivation of health care for a year.' He spoke of people prepared to do something that results in the avoidable death of their fellow human beings and it not bother them. This is the penny-drop I have been working to get across for more than 30 years – the level of pure evil we are dealing with. Yeadon said his friends and associates could not believe there could be that much evil, but he reminded them of Stalin, Pol Pot and Hitler and of what Stalin had said: 'One death is a tragedy. A million? A statistic.' He could not think of a benign explanation for why you need top-up vaccines 'which I'm sure you don't' and for the regulators 'to just get out of the way and wave them through'. Why would the regulators do that when they were still wrestling with the dangers of the 'parent' vaccine? He was clearly shocked by what he had seen since the 'Covid' hoax began and now he was thinking the previously unthinkable:

If you wanted to depopulate a significant proportion of the world and to do it in a way that doesn't involve destruction of the environment with nuclear weapons, poisoning everyone with anthrax or something like that, and you wanted plausible deniability while you had a multi-year infectious disease crisis, I actually don't think you could come up with a better plan of work than seems to be in front of me. I can't say that's what they are going to do, but I can't think of a benign explanation why they are doing it.

He said he never thought that they would get rid of 99 percent of humans, but now he wondered. 'If you wanted to that this would be a hell of a way to do it – it would be unstoppable folks.' Yeadon had concluded that those who submitted to the 'vaccine' would be allowed to have some kind of normal life (but for how long?) while screws were tightened to coerce and mandate the last few percent. 'I think they'll put the rest of them in a prison camp. I wish I was wrong, but I don't think I am.' Other points he made included: There were no coronavirus vaccines then suddenly they all come along at the same time; we have no idea of the long term affect with trials so short; coercing or forcing people to have medical procedures is against the Nuremberg Code instigated when the Nazis did just that; people should at least delay having the 'vaccine'; a quick Internet search confirms that masks don't reduce respiratory viral transmission and 'the government knows that'; they have smashed civil society and they know that, too; two dozen peer-reviewed studies show no connection between lockdown and reducing deaths; he knew from personal friends the elite were still flying around and going on holiday while the public were locked down; the elite were not having the 'vaccines'. He was also asked if 'vaccines' could be made to target difference races. He said he didn't know, but the document by the Project for the New American Century in September, 2000, said developing 'advanced forms of biological warfare that can target *specific genotypes* may transform biological warfare from the realm of terror to a politically useful tool.' Oh, they're evil all right. Of that we can be *absolutely* sure.

## **Another cull of old people**

We have seen from the CDC definition that the mRNA 'Covid vaccine' is not a vaccine and nor are the others that *claim* to reduce 'severity of symptoms' in *some* people, but not protect from infection or transmission. What about all the lies about returning to 'normal' if people were 'vaccinated'? If they are not claimed to stop infection and transmission of the alleged 'virus', how does anything change? This was all lies to manipulate people to take the jabs and we are seeing that now with masks and distancing still required for the 'vaccinated'. How did they think that elderly people with fragile health and immune responses were going to be affected by infusing their cells with synthetic material and other toxic substances? They *knew* that in the short and long term it would be devastating and fatal as the culling of the old that began with the first lockdowns was continued with the 'vaccine'. Death rates in care homes soared immediately residents began to be 'vaccinated' – infused with synthetic material. Brave and committed whistleblower nurses put their careers at risk by exposing this truth while the rest kept their heads down and their mouths shut to put their careers before those they are supposed to care for. A long-time American Certified Nursing Assistant who gave his name as James posted a video in which he described emotionally what happened in his care home when vaccination began. He said that during 2020 very few residents were sick with 'Covid' and no one died during the entire year; but shortly after the Pfizer mRNA injections 14 people died within two weeks and many others were near death. 'They're dropping like flies', he said. Residents who walked on their own before the shot could no longer and they had lost their ability to conduct an intelligent conversation. The home's management said the sudden deaths were caused by a 'super-spreader' of 'Covid-19'. Then how come, James asked, that residents who refused to take the injections were not sick? It was a case of inject the elderly with mRNA synthetic potions and blame their illness and death that followed on the 'virus'. James described what was happening in care homes as 'the greatest crime of genocide this country has ever seen'. Remember the NHS staff nurse from earlier who used the same

word 'genocide' for what was happening with the 'vaccines' and that it was an 'act of human annihilation'. A UK care home whistleblower told a similar story to James about the effect of the 'vaccine' in deaths and 'outbreaks' of illness dubbed 'Covid' after getting the jab. She told how her care home management and staff had zealously imposed government regulations and no one was allowed to even question the official narrative let alone speak out against it. She said the NHS was even worse. Again we see the results of reframing. A worker at a local care home where I live said they had not had a single case of 'Covid' there for almost a year and when the residents were 'vaccinated' they had 19 positive cases in two weeks with eight dying.

### **It's not the 'vaccine' – honest**

The obvious cause and effect was being ignored by the media and most of the public. Australia's health minister Greg Hunt (a former head of strategy at the World Economic Forum) was admitted to hospital after he had the 'vaccine'. He was suffering according to reports from the skin infection 'cellulitis' and it must have been a severe case to have warranted days in hospital. Immediately the authorities said this was nothing to do with the 'vaccine' when an effect of some vaccines is a 'cellulitis-like reaction'. We had families of perfectly healthy old people who died after the 'vaccine' saying that if only they had been given the 'vaccine' earlier they would still be alive. As a numbskull rating that is off the chart. A father of four 'died of Covid' at aged 48 when he was taken ill two days after having the 'vaccine'. The man, a health administrator, had been 'shielding during the pandemic' and had 'not really left the house' until he went for the 'vaccine'. Having the 'vaccine' and then falling ill and dying does not seem to have qualified as a possible cause and effect and 'Covid-19' went on his death certificate. His family said they had no idea how he 'caught the virus'. A family member said: 'Tragically, it could be that going for a vaccination ultimately led to him catching Covid ...The sad truth is that they are never going to know where it came from.' The family warned people to remember

that the virus still existed and was 'very real'. So was their stupidity. Nurses and doctors who had the first round of the 'vaccine' were collapsing, dying and ending up in a hospital bed while they or their grieving relatives were saying they'd still have the 'vaccine' again despite what happened. I kid you not. You mean if your husband returned from the dead he'd have the same 'vaccine' again that killed him??

Doctors at the VCU Medical Center in Richmond, Virginia, said the Johnson & Johnson 'vaccine' was to blame for a man's skin peeling off. Patient Richard Terrell said: 'It all just happened so fast. My skin peeled off. It's still coming off on my hands now.' He said it was stinging, burning and itching and when he bent his arms and legs it was very painful with 'the skin swollen and rubbing against itself'. Pfizer/BioNTech and Moderna vaccines use mRNA to change the cell while the Johnson & Johnson version uses DNA in a process similar to AstraZeneca's technique. Johnson & Johnson and AstraZeneca have both had their 'vaccines' paused by many countries after causing serious blood problems. Terrell's doctor Fnu Nutan said he could have died if he hadn't got medical attention. It sounds terrible so what did Nutan and Terrell say about the 'vaccine' now? Oh, they still recommend that people have it. A nurse in a hospital bed 40 minutes after the vaccination and unable to swallow due to throat swelling was told by a doctor that he lost mobility in his arm for 36 hours following the vaccination. What did he say to the ailing nurse? 'Good for you for getting the vaccination.' We are dealing with a serious form of cognitive dissonance madness in both public and medical staff. There is a remarkable correlation between those having the 'vaccine' and trumpeting the fact and suffering bad happenings shortly afterwards. Witold Rogiewicz, a Polish doctor, made a video of his 'vaccination' and ridiculed those who were questioning its safety and the intentions of Bill Gates: 'Vaccinate yourself to protect yourself, your loved ones, friends and also patients. And to mention quickly I have info for anti-vaxxers and anti-Coviders if you want to contact Bill Gates you can do this through me.' He further ridiculed the dangers of 5G. Days later he

was dead, but naturally the vaccination wasn't mentioned in the verdict of 'heart attack'.

## **Lies, lies and more lies**

So many members of the human race have slipped into extreme states of insanity and unfortunately they include reframed doctors and nursing staff. Having a 'vaccine' and dying within minutes or hours is not considered a valid connection while death from any cause within 28 days or longer of a positive test with a test not testing for the 'virus' means 'Covid-19' goes on the death certificate. How could that 'vaccine'-death connection not have been made except by calculated deceit? US figures in the initial rollout period to February 12th, 2020, revealed that a third of the deaths reported to the CDC after 'Covid vaccines' happened within 48 hours. Five men in the UK suffered an 'extremely rare' blood clot problem after having the AstraZeneca 'vaccine', but no causal link was established said the Gates-funded Medicines and Healthcare products Regulatory Agency (MHRA) which had given the 'vaccine' emergency approval to be used. Former Pfizer executive Dr Michael Yeadon explained in his interview how the procedures could cause blood coagulation and clots. People who should have been at no risk were dying from blood clots in the brain and he said he had heard from medical doctor friends that people were suffering from skin bleeding and massive headaches. The AstraZeneca 'shot' was stopped by some 20 countries over the blood clotting issue and still the corrupt MHRA, the European Medicines Agency (EMA) and the World Health Organization said that it should continue to be given even though the EMA admitted that it 'still cannot rule out definitively' a link between blood clotting and the 'vaccine'. Later Marco Cavaleri, head of EMA vaccine strategy, said there was indeed a clear link between the 'vaccine' and thrombosis, but they didn't know why. So much for the trials showing the 'vaccine' is safe. Blood clots were affecting younger people who would be under virtually no danger from 'Covid' even if it existed which makes it all the more stupid and sinister.

The British government responded to public alarm by wheeling out June Raine, the terrifyingly weak infant school headmistress sound-alike who heads the UK MHRA drug 'regulator'. The idea that she would stand up to Big Pharma and government pressure is laughable and she told us that all was well in the same way that she did when allowing untested, never-used-on-humans-before, genetically-manipulating 'vaccines' to be exposed to the public in the first place. Mass lying is the new normal of the 'Covid' era. The MHRA later said 30 cases of rare blood clots had by then been connected with the AstraZeneca 'vaccine' (that means a lot more in reality) while stressing that the benefits of the jab in preventing 'Covid-19' outweighed any risks. A more ridiculous and disingenuous statement with callous disregard for human health it is hard to contemplate. Immediately after the mendacious 'all-clears' two hospital workers in Denmark experienced blood clots and cerebral haemorrhaging following the AstraZeneca jab and one died. Top Norwegian health official Pål Andre Holme said the 'vaccine' was the only common factor: 'There is nothing in the patient history of these individuals that can give such a powerful immune response ... I am confident that the antibodies that we have found are the cause, and I see no other explanation than it being the vaccine which triggers it.' Strokes, a clot or bleed in the brain, were clearly associated with the 'vaccine' from word of mouth and whistleblower reports. Similar consequences followed with all these 'vaccines' that we were told were so safe and as the numbers grew by the day it was clear we were witnessing human carnage.

### **Learning the hard way**

A woman interviewed by UKColumn told how her husband suffered dramatic health effects after the vaccine when he'd been in good health all his life. He went from being a little unwell to losing all feeling in his legs and experiencing 'excruciating pain'. Misdiagnosis followed twice at Accident and Emergency (an 'allergy' and 'sciatica') before he was admitted to a neurology ward where doctors said his serious condition had been caused by the

'vaccine'. Another seven 'vaccinated' people were apparently being treated on the same ward for similar symptoms. The woman said he had the 'vaccine' because they believed media claims that it was safe. 'I didn't think the government would give out a vaccine that does this to somebody; I believed they would be bringing out a vaccination that would be safe.' What a tragic way to learn that lesson. Another woman posted that her husband was transporting stroke patients to hospital on almost every shift and when he asked them if they had been 'vaccinated' for 'Covid' they all replied 'yes'. One had a 'massive brain bleed' the day after his second dose. She said her husband reported the 'just been vaccinated' information every time to doctors in A and E only for them to ignore it, make no notes and appear annoyed that it was even mentioned. This particular report cannot be verified, but it expresses a common theme that confirms the monumental underreporting of 'vaccine' consequences. Interestingly as the 'vaccines' and their brain blood clot/stroke consequences began to emerge the UK National Health Service began a publicity campaign telling the public what to do in the event of a stroke. A Scottish NHS staff nurse who quit in disgust in March, 2021, said:

I have seen traumatic injuries from the vaccine, they're not getting reported to the yellow card [adverse reaction] scheme, they're treating the symptoms, not asking why, why it's happening. It's just treating the symptoms and when you speak about it you're dismissed like you're crazy, I'm not crazy, I'm not crazy because every other colleague I've spoken to is terrified to speak out, they've had enough.

Videos appeared on the Internet of people uncontrollably shaking after the 'vaccine' with no control over muscles, limbs and even their face. A Scottish mother broke out in a severe rash all over her body almost immediately after she was given the AstraZeneca 'vaccine'. The pictures were horrific. Leigh King, a 41-year-old hairdresser from Lanarkshire said: 'Never in my life was I prepared for what I was about to experience ... My skin was so sore and constantly hot ... I have never felt pain like this ...' But don't you worry, the 'vaccine' is perfectly safe. Then there has been the effect on medical



staff who have been pressured to have the 'vaccine' by psychopathic 'health' authorities and government. A London hospital consultant who gave the name K. Polyakova wrote this to the *British Medical Journal* or *BMJ*:

I am currently struggling with ... the failure to report the reality of the morbidity caused by our current vaccination program within the health service and staff population. The levels of sickness after vaccination is unprecedented and staff are getting very sick and some with neurological symptoms which is having a huge impact on the health service function. Even the young and healthy are off for days, some for weeks, and some requiring medical treatment. Whole teams are being taken out as they went to get vaccinated together.

Mandatory vaccination in this instance is stupid, unethical and irresponsible when it comes to protecting our staff and public health. We are in the voluntary phase of vaccination, and encouraging staff to take an unlicensed product that is impacting on their immediate health ... it is clearly stated that these vaccine products do not offer immunity or stop transmission. In which case why are we doing it?

Not to protect health that's for sure. Medical workers are lauded by governments for agenda reasons when they couldn't give a toss about them any more than they can for the population in general. Schools across America faced the same situation as they closed due to the high number of teachers and other staff with bad reactions to the Pfizer/BioNTech, Moderna, and Johnson & Johnson 'Covid vaccines' all of which were linked to death and serious adverse effects. The *BMJ* took down the consultant's comments pretty quickly on the grounds that they were being used to spread 'disinformation'. They were exposing the truth about the 'vaccine' was the real reason. The cover-up is breathtaking.

## **Hiding the evidence**

The scale of the 'vaccine' death cover-up worldwide can be confirmed by comparing official figures with the personal experience of the public. I heard of many people in my community who died immediately or soon after the vaccine that would never appear in the media or even likely on the official totals of 'vaccine' fatalities and adverse reactions when only about ten percent are estimated to be

reported and I have seen some estimates as low as one percent in a Harvard study. In the UK alone by April 29th, 2021, some 757,654 adverse reactions had been officially reported from the Pfizer/BioNTech, Oxford/AstraZeneca and Moderna 'vaccines' with more than a thousand deaths linked to jabs and that means an estimated ten times this number in reality from a ten percent reporting rate percentage. That's seven million adverse reactions and 10,000 potential deaths and a one percent reporting rate would be ten times *those* figures. In 1976 the US government pulled the swine flu vaccine after 53 deaths. The UK data included a combined 10,000 eye disorders from the 'Covid vaccines' with more than 750 suffering visual impairment or blindness and again multiply by the estimated reporting percentages. As 'Covid cases' officially fell hospitals virtually empty during the 'Covid crisis' began to fill up with a range of other problems in the wake of the 'vaccine' rollout. The numbers across America have also been catastrophic. Deaths linked to *all* types of vaccine increased by 6,000 percent in the first quarter of 2021 compared with 2020. A 39-year-old woman from Ogden, Utah, died four days after receiving a second dose of Moderna's 'Covid vaccine' when her liver, heart and kidneys all failed despite the fact that she had no known medical issues or conditions. Her family sought an autopsy, but Dr Erik Christensen, Utah's chief medical examiner, said proving vaccine injury as a cause of death almost never happened. He could think of only one instance where an autopsy would name a vaccine as the official cause of death and that would be anaphylaxis where someone received a vaccine and died almost instantaneously. 'Short of that, it would be difficult for us to definitively say this is the vaccine,' Christensen said. If that is true this must be added to the estimated ten percent (or far less) reporting rate of vaccine deaths and serious reactions and the conclusion can only be that vaccine deaths and serious reactions – including these 'Covid' potions' – are phenomenally understated in official figures. The same story can be found everywhere. Endless accounts of deaths and serious reactions among the public, medical

and care home staff while official figures did not even begin to reflect this.

Professional script-reader Dr David Williams, a 'top public-health official' in Ontario, Canada, insulted our intelligence by claiming only four serious adverse reactions and no deaths from the more than 380,000 vaccine doses then given. This bore no resemblance to what people knew had happened in their own circles and we had Dirk Huyer in charge of getting millions vaccinated in Ontario while at the same time he was Chief Coroner for the province investigating causes of death including possible death from the vaccine. An aide said he had stepped back from investigating deaths, but evidence indicated otherwise. Rosemary Frei, who secured a Master of Science degree in molecular biology at the Faculty of Medicine at Canada's University of Calgary before turning to investigative journalism, was one who could see that official figures for 'vaccine' deaths and reactions made no sense. She said that doctors seldom reported adverse events and when people got really sick or died after getting a vaccination they would attribute that to anything except the vaccines. It had been that way for years and anyone who wondered aloud whether the 'Covid vaccines' or other shots cause harm is immediately branded as 'anti-vax' and 'anti-science'. This was 'career-threatening' for health professionals. Then there was the huge pressure to support the push to 'vaccinate' billions in the quickest time possible. Frei said:

So that's where we're at today. More than half a million vaccine doses have been given to people in Ontario alone. The rush is on to vaccinate all 15 million of us in the province by September. And the mainstream media are screaming for this to be sped up even more. That all adds up to only a very slim likelihood that we're going to be told the truth by officials about how many people are getting sick or dying from the vaccines.

What is true of Ontario is true of everywhere.

### **They KNEW – and still did it**

The authorities knew what was going to happen with multiple deaths and adverse reactions. The UK government's Gates-funded

and Big Pharma-dominated Medicines and Healthcare products Regulatory Agency (MHRA) hired a company to employ AI in compiling the projected reactions to the 'vaccine' that would otherwise be uncountable. The request for applications said: 'The MHRA urgently seeks an Artificial Intelligence (AI) software tool to process the expected high volume of Covid-19 vaccine Adverse Drug Reaction ...' This was from the agency, headed by the disingenuous June Raine, that gave the 'vaccines' emergency approval and the company was hired before the first shot was given. 'We are going to kill and maim you – is that okay?' 'Oh, yes, perfectly fine – I'm very grateful, thank you, doctor.' The range of 'Covid vaccine' adverse reactions goes on for page after page in the MHRA criminally underreported 'Yellow Card' system and includes affects to eyes, ears, skin, digestion, blood and so on. Raine's MHRA amazingly claimed that the 'overall safety experience ... is so far as expected from the clinical trials'. The death, serious adverse effects, deafness and blindness were *expected*? When did they ever mention that? If these human tragedies were expected then those that gave approval for the use of these 'vaccines' must be guilty of crimes against humanity including murder – a definition of which is 'killing a person with malice aforethought or with recklessness manifesting extreme indifference to the value of human life.' People involved at the MHRA, the CDC in America and their equivalent around the world must go before Nuremberg trials to answer for their callous inhumanity. We are only talking here about the immediate effects of the 'vaccine'. The longer-term impact of the DNA synthetic manipulation is the main reason they are so hysterically desperate to inoculate the entire global population in the shortest possible time.

Africa and the developing world are a major focus for the 'vaccine' depopulation agenda and a mass vaccination sales-pitch is underway thanks to caring people like the Rockefellers and other Cult assets. The Rockefeller Foundation, which pre-empted the 'Covid pandemic' in a document published in 2010 that 'predicted' what happened a decade later, announced an initial \$34.95 million grant in February, 2021, 'to ensure more equitable access to Covid-19

testing and vaccines' among other things in Africa in collaboration with '24 organizations, businesses, and government agencies'. The pan-Africa initiative would focus on 10 countries: Burkina Faso, Ethiopia, Ghana, Kenya, Nigeria, Rwanda, South Africa, Tanzania, Uganda, and Zambia'. Rajiv Shah, President of the Rockefeller Foundation and former administrator of CIA-controlled USAID, said that if Africa was not mass-vaccinated (to change the DNA of its people) it was a 'threat to all of humanity' and not fair on Africans. When someone from the Rockefeller Foundation says they want to do something to help poor and deprived people and countries it is time for a belly-laugh. They are doing this out of the goodness of their 'heart' because 'vaccinating' the entire global population is what the 'Covid' hoax set out to achieve. Official 'decolonisation' of Africa by the Cult was merely a prelude to financial colonisation on the road to a return to physical colonisation. The 'vaccine' is vital to that and the sudden and convenient death of the 'Covid' sceptic president of Tanzania can be seen in its true light. A lot of people in Africa are aware that this is another form of colonisation and exploitation and they need to stand their ground.

### **The 'vaccine is working' scam**

A potential problem for the Cult was that the 'vaccine' is meant to change human DNA and body messaging and not to protect anyone from a 'virus' never shown to exist. The vaccine couldn't work because it was not designed to work and how could they make it *appear* to be working so that more people would have it? This was overcome by lowering the amplification rate of the PCR test to produce fewer 'cases' and therefore fewer 'deaths'. Some of us had been pointing out since March, 2020, that the amplification rate of the test not testing for the 'virus' had been made artificially high to generate positive tests which they could call 'cases' to justify lockdowns. The World Health Organization recommended an absurdly high 45 amplification cycles to ensure the high positives required by the Cult and then remained silent on the issue until January 20th, 2021 – Biden's Inauguration Day. This was when the

'vaccinations' were seriously underway and on that day the WHO recommended after discussions with America's CDC that laboratories *lowered their testing amplification*. Dr David Samadi, a certified urologist and health writer, said the WHO was encouraging all labs to reduce their cycle count for PCR tests. He said the current cycle was much too high and was 'resulting in any particle being declared a positive case'. Even one mainstream news report I saw said this meant the number of 'Covid' infections may have been 'dramatically inflated'. Oh, just a little bit. The CDC in America issued new guidance to laboratories in April, 2021, to use 28 cycles *but only for 'vaccinated' people*. The timing of the CDC/WHO interventions were cynically designed to make it appear the 'vaccines' were responsible for falling cases and deaths when the real reason can be seen in the following examples. New York's state lab, the Wadsworth Center, identified 872 positive tests in July, 2020, based on a threshold of 40 cycles. When the figure was lowered to 35 cycles 43 percent of the 872 were no longer 'positives'. At 30 cycles the figure was 63 percent. A Massachusetts lab found that between 85 to 90 percent of people who tested positive in July with a cycle threshold of 40 would be negative at 30 cycles, Ashish Jha, MD, director of the Harvard Global Health Institute, said: 'I'm really shocked that it could be that high ... Boy, does it really change the way we need to be thinking about testing.' I'm shocked that I could see the obvious in the spring of 2020, with no medical background, and most medical professionals still haven't worked it out. No, that's not shocking – it's terrifying.

Three weeks after the WHO directive to lower PCR cycles the London *Daily Mail* ran this headline: 'Why ARE Covid cases plummeting? New infections have fallen 45% in the US and 30% globally in the past 3 weeks but experts say vaccine is NOT the main driver because only 8% of Americans and 13% of people worldwide have received their first dose.' They acknowledged that the drop could not be attributed to the 'vaccine', but soon this morphed throughout the media into the 'vaccine' has caused cases and deaths to fall when it was the PCR threshold. In December, 2020, there was

chaos at English Channel ports with truck drivers needing negative 'Covid' tests before they could board a ferry home for Christmas. The government wanted to remove the backlog as fast as possible and they brought in troops to do the 'testing'. Out of 1,600 drivers just 36 tested positive and the rest were given the all clear to cross the Channel. I guess the authorities thought that 36 was the least they could get away with without the unquestioning catching on. The amplification trick which most people believed in the absence of information in the mainstream applied more pressure on those refusing the 'vaccine' to succumb when it 'obviously worked'. The truth was the exact opposite with deaths in care homes soaring with the 'vaccine' and in Israel the term used was 'skyrocket'. A re-analysis of published data from the Israeli Health Ministry led by Dr Hervé Seligmann at the Medicine Emerging Infectious and Tropical Diseases at Aix-Marseille University found that Pfizer's 'Covid vaccine' killed 'about 40 times more [elderly] people than the disease itself would have killed' during a five-week vaccination period and *260 times* more younger people than would have died from the 'virus' even according to the manipulated 'virus' figures. Dr Seligmann and his co-study author, Haim Yativ, declared after reviewing the Israeli 'vaccine' death data: 'This is a new Holocaust.'

Then, in mid-April, 2021, after vast numbers of people worldwide had been 'vaccinated', the story changed with clear coordination. The UK government began to prepare the ground for more future lockdowns when Nuremberg-destined Boris Johnson told yet another whopper. He said that cases had fallen because of *lockdowns* not 'vaccines'. Lockdowns are irrelevant when *there is no 'virus'* and the test and fraudulent death certificates are deciding the number of 'cases' and 'deaths'. Study after study has shown that lockdowns don't work and instead kill and psychologically destroy people. Meanwhile in the United States Anthony Fauci and Rochelle Walensky, the ultra-Zionist head of the CDC, peddled the same line. More lockdown was the answer and not the 'vaccine', a line repeated on cue by the moron that is Canadian Prime Minister Justin Trudeau. Why all the hysteria to get everyone 'vaccinated' if lockdowns and

not 'vaccines' made the difference? None of it makes sense on the face of it. Oh, but it does. The Cult wants lockdowns *and* the 'vaccine' and if the 'vaccine' is allowed to be seen as the total answer lockdowns would no longer be justified when there are still livelihoods to destroy. 'Variants' and renewed upward manipulation of PCR amplification are planned to instigate never-ending lockdown *and* more 'vaccines'.

### **You *must* have it – we're desperate**

Israel, where the Jewish and Arab population are ruled by the Sabbatian Cult, was the front-runner in imposing the DNA-manipulating 'vaccine' on its people to such an extent that Jewish refusers began to liken what was happening to the early years of Nazi Germany. This would seem to be a fantastic claim. Why would a government of Jewish people be acting like the Nazis did? If you realise that the Sabbatian Cult was behind the Nazis and that Sabbatians hate Jews the pieces start to fit and the question of why a 'Jewish' government would treat Jews with such callous disregard for their lives and freedom finds an answer. Those controlling the government of Israel *aren't Jewish* – they're Sabbatian. Israeli lawyer Tamir Turgal was one who made the Nazi comparison in comments to German lawyer Reiner Fuellmich who is leading a class action lawsuit against the psychopaths for crimes against humanity. Turgal described how the Israeli government was vaccinating children and pregnant women on the basis that there was no evidence that this was dangerous when they had no evidence that it *wasn't* dangerous either. They just had no evidence. This was medical experimentation and Turgal said this breached the Nuremberg Code about medical experimentation and procedures requiring informed consent and choice. Think about that. A Nuremberg Code developed because of Nazi experimentation on Jews and others in concentration camps by people like the evil-beyond-belief Josef Mengele is being breached by the *Israeli* government; but when you know that it's a *Sabbatian* government along with its intelligence and military agencies like Mossad, Shin Bet and the Israeli Defense Forces, and that Sabbatians



were the force behind the Nazis, the kaleidoscope comes into focus. What have we come to when Israeli Jews are suing their government for violating the Nuremberg Code by essentially making Israelis subject to a medical experiment using the controversial 'vaccines'? It's a shocker that this has to be done in the light of what happened in Nazi Germany. The Anshe Ha-Emet, or 'People of the Truth', made up of Israeli doctors, lawyers, campaigners and public, have launched a lawsuit with the International Criminal Court. It says:

When the heads of the Ministry of Health as well as the prime minister presented the vaccine in Israel and began the vaccination of Israeli residents, the vaccinated were not advised, that, in practice, they are taking part in a medical experiment and that their consent is required for this under the Nuremberg Code.

The irony is unbelievable, but easily explained in one word: Sabbatians. The foundation of Israeli 'Covid' apartheid is the 'green pass' or 'green passport' which allows Jews and Arabs who have had the DNA-manipulating 'vaccine' to go about their lives – to work, fly, travel in general, go to shopping malls, bars, restaurants, hotels, concerts, gyms, swimming pools, theatres and sports venues, while non-'vaccinated' are banned from all those places and activities. Israelis have likened the 'green pass' to the yellow stars that Jews in Nazi Germany were forced to wear – the same as the yellow stickers that a branch of UK supermarket chain Morrisons told exempt mask-wearers they had to display when shopping. How very sensitive. The Israeli system is blatant South African-style apartheid on the basis of compliance or non-compliance to fascism rather than colour of the skin. How appropriate that the Sabbatian Israeli government was so close to the pre-Mandela apartheid regime in Pretoria. The Sabbatian-instigated 'vaccine passport' in Israel is planned for everywhere. Sabbatians struck a deal with Pfizer that allowed them to lead the way in the percentage of a national population infused with synthetic material and the result was catastrophic. Israeli freedom activist Shai Dannon told me how chairs were appearing on beaches that said 'vaccinated only'. Health Minister Yuli Edelstein said that anyone unwilling or unable to get

the jabs that 'confer immunity' will be 'left behind'. The man's a liar. Not even the makers claim the 'vaccines' confer immunity. When you see those figures of 'vaccine' deaths these psychopaths were saying that you must take the chance the 'vaccine' will kill you or maim you while knowing it will change your DNA or lockdown for you will be permanent. That's fascism. The Israeli parliament passed a law to allow personal information of the non-vaccinated to be shared with local and national authorities for three months. This was claimed by its supporters to be a way to 'encourage' people to be vaccinated. Hadas Ziv from Physicians for Human Rights described this as a 'draconian law which crushed medical ethics and the patient rights'. But that's the idea, the Sabbatians would reply.

### **Your papers, please**

Sabbatian Israel was leading what has been planned all along to be a global 'vaccine pass' called a 'green passport' without which you would remain in permanent lockdown restriction and unable to do anything. This is how badly – *desperately* – the Cult is to get everyone 'vaccinated'. The term and colour 'green' was not by chance and related to the psychology of fusing the perception of the green climate hoax with the 'Covid' hoax and how the 'solution' to both is the same Great Reset. Lying politicians, health officials and psychologists denied there were any plans for mandatory vaccinations or restrictions based on vaccinations, but they knew that was exactly what was meant to happen with governments of all countries reaching agreements to enforce a global system. 'Free' Denmark and 'free' Sweden unveiled digital vaccine certification. Cyprus, Czech Republic, Estonia, Greece, Hungary, Iceland, Italy, Poland, Portugal, Slovakia, and Spain have all committed to a vaccine passport system and the rest including the whole of the EU would follow. The satanic UK government will certainly go this way despite mendacious denials and at the time of writing it is trying to manipulate the public into having the 'vaccine' so they could go abroad on a summer holiday. How would that work without something to prove you had the synthetic toxicity injected into you?

Documents show that the EU's European Commission was moving towards 'vaccine certificates' in 2018 and 2019 before the 'Covid' hoax began. They knew what was coming. Abracadabra – Ursula von der Leyen, the German President of the Commission, announced in March, 2021, an EU 'Digital Green Certificate' – green again – to track the public's 'Covid status'. The passport sting is worldwide and the Far East followed the same pattern with South Korea ruling that only those with 'vaccination' passports – again the *green* pass – would be able to 'return to their daily lives'.

Bill Gates has been preparing for this 'passport' with other Cult operatives for years and beyond the paper version is a Gates-funded 'digital tattoo' to identify who has been vaccinated and who hasn't. The 'tattoo' is reported to include a substance which is externally readable to confirm who has been vaccinated. This is a bio-luminous light-generating enzyme (think fireflies) called ... *Luciferase*. Yes, named after the Cult 'god' Lucifer the 'light bringer' of whom more to come. Gates said he funded the readable tattoo to ensure children in the developing world were vaccinated and no one was missed out. He cares so much about poor kids as we know. This was just the cover story to develop a vaccine tagging system for everyone on the planet. Gates has been funding the ID2020 'alliance' to do just that in league with other lovely people at Microsoft, GAVI, the Rockefeller Foundation, Accenture and IDEO.org. He said in interviews in March, 2020, before any 'vaccine' publicly existed, that the world must have a globalised digital certificate to track the 'virus' and who had been vaccinated. Gates knew from the start that the mRNA vaccines were coming and when they would come and that the plan was to tag the 'vaccinated' to marginalise the intelligent and stop them doing anything including travel. Evil just doesn't suffice. Gates was exposed for offering a \$10 million bribe to the Nigerian House of Representatives to invoke compulsory 'Covid' vaccination of all Nigerians. Sara Cunial, a member of the Italian Parliament, called Gates a 'vaccine criminal'. She urged the Italian President to hand him over to the International Criminal Court for crimes against

humanity and condemned his plans to 'chip the human race' through ID2020.

You know it's a long-planned agenda when war criminal and Cult gofer Tony Blair is on the case. With the scale of arrogance only someone as dark as Blair can muster he said: 'Vaccination in the end is going to be your route to liberty.' Blair is a disgusting piece of work and he confirms that again. The media has given a lot of coverage to a bloke called Charlie Mullins, founder of London's biggest independent plumbing company, Pimlico Plumbers, who has said he won't employ anyone who has not been vaccinated or have them go to any home where people are not vaccinated. He said that if he had his way no one would be allowed to walk the streets if they have not been vaccinated. Gates was cheering at the time while I was alerting the white coats. The plan is that people will qualify for 'passports' for having the first two doses and then to keep it they will have to have all the follow ups and new ones for invented 'variants' until human genetics is transformed and many are dead who can't adjust to the changes. Hollywood celebrities – the usual propaganda stunt – are promoting something called the WELL Health-Safety Rating to verify that a building or space has 'taken the necessary steps to prioritize the health and safety of their staff, visitors and other stakeholders'. They included Lady Gaga, Jennifer Lopez, Michael B. Jordan, Robert DeNiro, Venus Williams, Wolfgang Puck, Deepak Chopra and 17th Surgeon General Richard Carmona. Yawn. WELL Health-Safety has big connections with China. Parent company Delos is headed by former Goldman Sachs partner Paul Scialla. This is another example – and we will see so many others – of using the excuse of 'health' to dictate the lives and activities of the population. I guess one confirmation of the 'safety' of buildings is that only 'vaccinated' people can go in, right?

## **Electronic concentration camps**

I wrote decades ago about the plans to restrict travel and here we are for those who refuse to bow to tyranny. This can be achieved in one go with air travel if the aviation industry makes a blanket decree.

The 'vaccine' and guaranteed income are designed to be part of a global version of China's social credit system which tracks behaviour 24/7 and awards or deletes 'credits' based on whether your behaviour is supported by the state or not. I mean your entire lifestyle – what you do, eat, say, everything. Once your credit score falls below a certain level consequences kick in. In China tens of millions have been denied travel by air and train because of this. All the locations and activities denied to refusers by the 'vaccine' passports will be included in one big mass ban on doing almost anything for those that don't bow their head to government. It's beyond fascist and a new term is required to describe its extremes – I guess fascist technocracy will have to do. The way the Chinese system of technological – technocratic – control is sweeping the West can be seen in the Los Angeles school system and is planned to be expanded worldwide. Every child is required to have a 'Covid'-tracking app scanned daily before they can enter the classroom. The so-called Daily Pass tracking system is produced by Gates' Microsoft which I'm sure will shock you rigid. The pass will be scanned using a barcode (one step from an inside-the-body barcode) and the information will include health checks, 'Covid' tests and vaccinations. Entry codes are for one specific building only and access will only be allowed if a student or teacher has a negative test with a test not testing for the 'virus', has no symptoms of anything alleged to be related to 'Covid' (symptoms from a range of other illness), and has a temperature under 100 degrees. No barcode, no entry, is planned to be the case for everywhere and not only schools.

Kids are being psychologically prepared to accept this as 'normal' their whole life which is why what they can impose in schools is so important to the Cult and its gofers. Long-time American freedom campaigner John Whitehead of the Rutherford Institute was not exaggerating when he said: 'Databit by databit, we are building our own electronic concentration camps.' Canada under its Cult gofer prime minister Justin Trudeau has taken a major step towards the real thing with people interned against their will if they test positive with a test not testing for the 'virus' when they arrive at a Canadian

airport. They are jailed in internment hotels often without food or water for long periods and with many doors failing to lock there have been sexual assaults. The interned are being charged sometimes \$2,000 for the privilege of being abused in this way. Trudeau is fully on board with the Cult and says the 'Covid pandemic' has provided an opportunity for a global 'reset' to permanently change Western civilisation. His number two, Deputy Prime Minister Chrystia Freeland, is a trustee of the World Economic Forum and a Rhodes Scholar. The Trudeau family have long been servants of the Cult. See *The Biggest Secret* and Cathy O'Brien's book *Trance-Formation of America* for the horrific background to Trudeau's father Pierre Trudeau another Canadian prime minister. Hide your fascism behind the façade of a heart-on-the-sleeve liberal. It's a well-honed Cult technique.

### **What can the 'vaccine' really do?**

We have a 'virus' never shown to exist and 'variants' of the 'virus' that have also never been shown to exist except, like the 'original', as computer-generated fictions. Even if you believe there's a 'virus' the 'case' to 'death' rate is in the region of 0.23 to 0.15 percent and those 'deaths' are concentrated among the very old around the same average age that people die anyway. In response to this lack of threat (in truth none) psychopaths and idiots, knowingly and unknowingly answering to Gates and the Cult, are seeking to 'vaccinate' every man, woman and child on Planet Earth. Clearly the 'vaccine' is not about 'Covid' – none of this ever has been. So what is it all about *really*? Why the desperation to infuse genetically-manipulating synthetic material into everyone through mRNA fraudulent 'vaccines' with the intent of doing this over and over with the excuses of 'variants' and other 'virus' inventions? Dr Sherri Tenpenny, an osteopathic medical doctor in the United States, has made herself an expert on vaccines and their effects as a vehement campaigner against their use. Tenpenny was board certified in emergency medicine, the director of a level two trauma centre for 12 years, and moved to Cleveland in 1996 to start an integrative

medicine practice which has treated patients from all 50 states and some 17 other countries. Weaning people off pharmaceutical drugs is a speciality.

She became interested in the consequences of vaccines after attending a meeting at the National Vaccine Information Center in Washington DC in 2000 where she 'sat through four days of listening to medical doctors and scientists and lawyers and parents of vaccine injured kids' and asked: 'What's going on?' She had never been vaccinated and never got ill while her father was given a list of vaccines to be in the military and was 'sick his entire life'. The experience added to her questions and she began to examine vaccine documents from the Centers for Disease Control (CDC). After reading the first one, the 1998 version of *The General Recommendations of Vaccination*, she thought: 'This is it?' The document was poorly written and bad science and Tenpenny began 20 years of research into vaccines that continues to this day. She began her research into 'Covid vaccines' in March, 2020, and she describes them as 'deadly'. For many, as we have seen, they already have been. Tenpenny said that in the first 30 days of the 'vaccine' rollout in the United States there had been more than 40,000 adverse events reported to the vaccine adverse event database. A document had been delivered to her the day before that was 172 pages long. 'We have over 40,000 adverse events; we have over 3,100 cases of [potentially deadly] anaphylactic shock; we have over 5,000 neurological reactions.' Effects ranged from headaches to numbness, dizziness and vertigo, to losing feeling in hands or feet and paraesthesia which is when limbs 'fall asleep' and people have the sensation of insects crawling underneath their skin. All this happened in the first 30 days and remember that only about *ten percent* (or far less) of adverse reactions and vaccine-related deaths are estimated to be officially reported. Tenpenny said:

So can you think of one single product in any industry, any industry, for as long as products have been made on the planet that within 30 days we have 40,000 people complaining of side effects that not only is still on the market but ... we've got paid actors telling us how great

they are for getting their vaccine. We're offering people \$500 if they will just get their vaccine and we've got nurses and doctors going; 'I got the vaccine, I got the vaccine'.

Tenpenny said they were not going to be 'happy dancing folks' when they began to suffer Bell's palsy (facial paralysis), neuropathies, cardiac arrhythmias and autoimmune reactions that kill through a blood disorder. 'They're not going to be so happy, happy then, but we're never going to see pictures of those people' she said. Tenpenny described the 'vaccine' as 'a well-designed killing tool'.

## **No off-switch**

Bad as the initial consequences had been Tenpenny said it would be maybe 14 months before we began to see the 'full ravage' of what is going to happen to the 'Covid vaccinated' with full-out consequences taking anything between two years and 20 years to show. You can understand why when you consider that variations of the 'Covid vaccine' use mRNA (messenger RNA) to in theory activate the immune system to produce protective antibodies without using the actual 'virus'. How can they when it's a computer program and they've never isolated what they claim is the 'real thing'? Instead they use *synthetic* mRNA. They are inoculating synthetic material into the body which through a technique known as the Trojan horse is absorbed into cells to change the nature of DNA. Human DNA is changed by an infusion of messenger RNA and with each new 'vaccine' of this type it is changed even more. Say so and you are banned by Cult Internet platforms. The contempt the contemptuous Mark Zuckerberg has for the truth and human health can be seen in an internal Facebook video leaked to the Project Veritas investigative team in which he said of the 'Covid vaccines': '... I share some caution on this because we just don't know the long term side-effects of basically modifying people's DNA and RNA.' At the same time this disgusting man's Facebook was censoring and banning anyone saying exactly the same. He must go before a Nuremberg trial for crimes against humanity when he *knows* that he



is censoring legitimate concerns and denying the right of informed consent on behalf of the Cult that owns him. People have been killed and damaged by the very 'vaccination' technique he cast doubt on himself when they may not have had the 'vaccine' with access to information that he denied them. The plan is to have at least annual 'Covid vaccinations', add others to deal with invented 'variants', and change all other vaccines into the mRNA system. Pfizer executives told shareholders at a virtual Barclays Global Healthcare Conference in March, 2021, that the public may need a third dose of 'Covid vaccine', plus regular yearly boosters and the company planned to hike prices to milk the profits in a 'significant opportunity for our vaccine'. These are the professional liars, cheats and opportunists who are telling you their 'vaccine' is safe. Given this volume of mRNA planned to be infused into the human body and its ability to then replicate we will have a transformation of human genetics from biological to synthetic biological – exactly the long-time Cult plan for reasons we'll see – and many will die. Sherri Tenpenny said of this replication:

It's like having an on-button but no off-button and that whole mechanism ... they actually give it a name and they call it the Trojan horse mechanism, because it allows that [synthetic] virus and that piece of that [synthetic] virus to get inside of your cells, start to replicate and even get inserted into other parts of your DNA as a Trojan-horse.

Ask the overwhelming majority of people who have the 'vaccine' what they know about the contents and what they do and they would reply: 'The government says it will stop me getting the virus.' Governments give that false impression on purpose to increase take-up. You can read Sherri Tenpenny's detailed analysis of the health consequences in her blog at [Vaxxter.com](https://www.vaxxter.com), but in summary these are some of them. She highlights the statement by Bill Gates about how human beings can become their own 'vaccine manufacturing machine'. The man is insane. ['Vaccine'-generated] 'antibodies' carry synthetic messenger RNA into the cells and the damage starts, Tenpenny contends, and she says that lungs can be adversely affected through varying degrees of pus and bleeding which

obviously affects breathing and would be dubbed 'Covid-19'. Even more sinister was the impact of 'antibodies' on macrophages, a white blood cell of the immune system. They consist of Type 1 and Type 2 which have very different functions. She said Type 1 are 'hyper-vigilant' white blood cells which 'gobble up' bacteria etc. However, in doing so, this could cause inflammation and in extreme circumstances be fatal. She says these affects are mitigated by Type 2 macrophages which kick in to calm down the system and stop it going rogue. They clear up dead tissue debris and reduce inflammation that the Type 1 'fire crews' have caused. Type 1 kills the infection and Type 2 heals the damage, she says. This is her punchline with regard to 'Covid vaccinations': She says that mRNA 'antibodies' block Type 2 macrophages by attaching to them and deactivating them. This meant that when the Type 1 response was triggered by infection there was nothing to stop that getting out of hand by calming everything down. There's an on-switch, but no off-switch, she says. What follows can be 'over and out, see you when I see you'.

## **Genetic suicide**

Tenpenny also highlights the potential for autoimmune disease – the body attacking itself – which has been associated with vaccines since they first appeared. Infusing a synthetic foreign substance into cells could cause the immune system to react in a panic believing that the body is being overwhelmed by an invader (it is) and the consequences can again be fatal. There is an autoimmune response known as a 'cytokine storm' which I have likened to a homeowner panicked by an intruder and picking up a gun to shoot randomly in all directions before turning the fire on himself. The immune system unleashes a storm of inflammatory response called cytokines to a threat and the body commits hara-kiri. The lesson is that you mess with the body's immune response at your peril and these 'vaccines' seriously – fundamentally – mess with immune response. Tenpenny refers to a consequence called anaphylactic shock which is a severe and highly dangerous allergic reaction when the immune system

floods the body with chemicals. She gives the example of having a bee sting which primes the immune system and makes it sensitive to those chemicals. When people are stung again maybe years later the immune response can be so powerful that it leads to anaphylactic shock. Tenpenny relates this 'shock' with regard to the 'Covid vaccine' to something called polyethylene glycol or PEG. Enormous numbers of people have become sensitive to this over decades of use in a whole range of products and processes including food, drink, skin creams and 'medicine'. Studies have claimed that some 72 percent of people have antibodies triggered by PEG compared with two percent in the 1960s and allergic hypersensitive reactions to this become a gathering cause for concern. Tenpenny points out that the 'mRNA vaccine' is coated in a 'bubble' of polyethylene glycol which has the potential to cause anaphylactic shock through immune sensitivity. Many reports have appeared of people reacting this way after having the 'Covid vaccine'. What do we think is going to happen as humanity has more and more of these 'vaccines'?

Tenpenny said: 'All these pictures we have seen with people with these rashes ... these weepy rashes, big reactions on their arms and things like that – it's an acute allergic reaction most likely to the polyethylene glycol that you've been previously primed and sensitised to.'

Those who have not studied the conspiracy and its perpetrators at length might think that making the population sensitive to PEG and then putting it in these 'vaccines' is just a coincidence. It is not. It is instead testament to how carefully and coldly-planned current events have been and the scale of the conspiracy we are dealing with. Tenpenny further explains that the 'vaccine' mRNA procedure can breach the blood-brain barrier which protects the brain from toxins and other crap that will cause malfunction. In this case they could make two proteins corrupt brain function to cause Amyotrophic lateral sclerosis (ALS), a progressive nervous system disease leading to loss of muscle control, and frontal lobe degeneration – Alzheimer's and dementia. Immunologist J. Bart Classon published a paper connecting mRNA 'vaccines' to prion

disease which can lead to Alzheimer's and other forms of neurodegenerative disease while others have pointed out the potential to affect the placenta in ways that make women infertile. This will become highly significant in the next chapter when I will discuss other aspects of this non-vaccine that relate to its nanotechnology and transmission from the injected to the uninjected.

## **Qualified in idiocy**

Tenpenny describes how research has confirmed that these 'vaccine'-generated antibodies can interact with a range of other tissues in the body and attack many other organs including the lungs. 'This means that if you have a hundred people standing in front of you that all got this shot they could have a hundred different symptoms.'

Anyone really think that Cult gofers like the Queen, Tony Blair, Christopher Whitty, Anthony Fauci, and all the other psychopaths have really had this 'vaccine' in the pictures we've seen? Not a bloody chance. Why don't doctors all tell us about all these dangers and consequences of the 'Covid vaccine'? Why instead do they encourage and pressure patients to have the shot? Don't let's think for a moment that doctors and medical staff can't be stupid, lazy, and psychopathic and that's without the financial incentives to give the jab. Tenpenny again:

Some people are going to die from the vaccine directly but a large number of people are going to start to get horribly sick and get all kinds of autoimmune diseases 42 days to maybe a year out. What are they going to do, these stupid doctors who say; 'Good for you for getting that vaccine.' What are they going to say; 'Oh, it must be a mutant, we need to give an extra dose of that vaccine.'

Because now the vaccine, instead of one dose or two doses we need three or four because the stupid physicians aren't taking the time to learn anything about it. If I can learn this sitting in my living room reading a 19 page paper and several others so can they. There's nothing special about me, I just take the time to do it.

Remember how Sara Kayat, the NHS and TV doctor, said that the 'Covid vaccine' would '100 percent prevent hospitalisation and death'. Doctors can be idiots like every other profession and they

should not be worshipped as infallible. They are not and far from it. Behind many medical and scientific 'experts' lies an uninformed prat trying to hide themselves from you although in the 'Covid' era many have failed to do so as with UK narrative-repeating 'TV doctor' Hilary Jones. Pushing back against the minority of proper doctors and scientists speaking out against the 'vaccine' has been the entire edifice of the Cult global state in the form of governments, medical systems, corporations, mainstream media, Silicon Valley, and an army of compliant doctors, medical staff and scientists willing to say anything for money and to enhance their careers by promoting the party line. If you do that you are an 'expert' and if you won't you are an 'anti-vaxxer' and 'Covidiot'. The pressure to be 'vaccinated' is incessant. We have even had reports claiming that the 'vaccine' can help cure cancer and Alzheimer's and make the lame walk. I am waiting for the announcement that it can bring you coffee in the morning and cook your tea. Just as the symptoms of 'Covid' seem to increase by the week so have the miracles of the 'vaccine'. American supermarket giant Kroger Co. offered nearly 500,000 employees in 35 states a \$100 bonus for having the 'vaccine' while donut chain Krispy Kreme promised 'vaccinated' customers a free glazed donut every day for the rest of 2021. Have your DNA changed and you will get a doughnut although we might not have to give you them for long. Such offers and incentives confirm the desperation.

Perhaps the worse vaccine-stunt of them all was UK 'Health' Secretary Matt-the-prat Hancock on live TV after watching a clip of someone being 'vaccinated' when the roll-out began. Hancock faked tears so badly it was embarrassing. Brain-of-Britain Piers Morgan, the lockdown-supporting, 'vaccine' supporting, 'vaccine' passport-supporting, TV host played along with Hancock – 'You're quite emotional about that' he said in response to acting so atrocious it would have been called out at a school nativity which will presumably today include Mary and Jesus in masks, wise men keeping their camels six feet apart, and shepherds under tent arrest. System-serving Morgan tweeted this: 'Love the idea of covid vaccine passports for everywhere: flights, restaurants, clubs, football, gyms,

shops etc. It's time covid-denying, anti-vaxxer loonies had their bullsh\*t bluff called & bar themselves from going anywhere that responsible citizens go.' If only I could aspire to his genius. To think that Morgan, who specialises in shouting over anyone he disagrees with, was lauded as a free speech hero when he lost his job after storming off the set of his live show like a child throwing his dolly out of the pram. If he is a free speech hero we are in real trouble. I have no idea what 'bullsh\*t' means, by the way, the \* throws me completely.

The Cult is desperate to infuse its synthetic DNA-changing concoction into everyone and has been using every lie, trick and intimidation to do so. The question of '*Why?*' we shall now address.

## CHAPTER TEN

### Human 2.0

*I believe that at the end of the century the use of words and general educated opinion will have altered so much that one will be able to speak of machines thinking without expecting to be contradicted – Alan Turing (1912-1954), the ‘Father of artificial intelligence’*

I have been exposing for decades the plan to transform the human body from a biological to a synthetic-biological state. The new human that I will call Human 2.0 is planned to be connected to artificial intelligence and a global AI ‘Smart Grid’ that would operate as one global system in which AI would control everything from your fridge to your heating system to your car to your mind. Humans would no longer be ‘human’, but post-human and sub-human, with their thinking and emotional processes replaced by AI.

What I said sounded crazy and beyond science fiction and I could understand that. To any balanced, rational, mind it *is* crazy. Today, however, that world is becoming reality and it puts the ‘Covid vaccine’ into its true context. Ray Kurzweil is the ultra-Zionist ‘computer scientist, inventor and futurist’ and co-founder of the Singularity University. Singularity refers to the merging of humans with machines or ‘transhumanism’. Kurzweil has said humanity would be connected to the cyber ‘cloud’ in the period of the ever-recurring year of 2030:

Our thinking ... will be a hybrid of biological and non-biological thinking ... humans will be able to extend their limitations and ‘think in the cloud’ ... We’re going to put gateways to the

cloud in our brains ... We're going to gradually merge and enhance ourselves ... In my view, that's the nature of being human – we transcend our limitations. As the technology becomes vastly superior to what we are then the small proportion that is still human gets smaller and smaller and smaller until it's just utterly negligible.

They are trying to sell this end-of-humanity-as-we-know-it as the next stage of 'evolution' when we become super-human and 'like the gods'. They are lying to you. Shocked, eh? The population, and again especially the young, have been manipulated into addiction to technologies designed to enslave them for life. First they induced an addiction to smartphones (holdables); next they moved to technology on the body (wearables); and then began the invasion of the body (implantables). I warned way back about the plan for microchipped people and we are now entering that era. We should not be diverted into thinking that this refers only to chips we can see. Most important are the nanochips known as smart dust, neural dust and nanobots which are far too small to be seen by the human eye. Nanotechnology is everywhere, increasingly in food products, and released into the atmosphere by the geoengineering of the skies funded by Bill Gates to 'shut out the Sun' and 'save the planet from global warming'. Gates has been funding a project to spray millions of tonnes of chalk (calcium carbonate) into the stratosphere over Sweden to 'dim the Sun' and cool the Earth. Scientists warned the move could be disastrous for weather systems in ways no one can predict and opposition led to the Swedish space agency announcing that the 'experiment' would not be happening as planned in the summer of 2021; but it shows where the Cult is going with dimming the impact of the Sun and there's an associated plan to change the planet's atmosphere. Who gives psychopath Gates the right to dictate to the entire human race and dismantle planetary systems? The world will not be safe while this man is at large.

The global warming hoax has made the Sun, like the gas of life, something to fear when both are essential to good health and human survival (more inversion). The body transforms sunlight into vital vitamin D through a process involving ... *cholesterol*. This is the cholesterol we are also told to fear. We are urged to take Big Pharma



statin drugs to reduce cholesterol and it's all systematic. Reducing cholesterol means reducing vitamin D uptake with all the multiple health problems that will cause. At least if you take statins long term it saves the government from having to pay you a pension. The delivery system to block sunlight is widely referred to as chemtrails although these have a much deeper agenda, too. They appear at first to be contrails or condensation trails streaming from aircraft into cold air at high altitudes. Contrails disperse very quickly while chemtrails do not and spread out across the sky before eventually their content falls to earth. Many times I have watched aircraft cross-cross a clear blue sky releasing chemtrails until it looks like a cloudy day. Chemtrails contain many things harmful to humans and the natural world including toxic heavy metals, aluminium (see Alzheimer's) and nanotechnology. Ray Kurzweil reveals the reason without actually saying so: 'Nanobots will infuse all the matter around us with information. Rocks, trees, everything will become these intelligent creatures.' How do you deliver that? *From the sky*. Self-replicating nanobots would connect everything to the Smart Grid. The phenomenon of Morgellons disease began in the chemtrail era and the correlation has led to it being dubbed the 'chemtrail disease'. Self-replicating fibres appear in the body that can be pulled out through the skin. Morgellons fibres continue to grow outside the body and have a form of artificial intelligence. I cover this at greater length in *Phantom Self*.

### **'Vaccine' operating system**

'Covid vaccines' with their self-replicating synthetic material are also designed to make the connection between humanity and Kurzweil's 'cloud'. American doctor and dedicated campaigner for truth, Carrie Madej, an Internal Medicine Specialist in Georgia with more than 20 years medical experience, has highlighted the nanotechnology aspect of the fake 'vaccines'. She explains how one of the components in at least the Moderna and Pfizer synthetic potions are 'lipid nanoparticles' which are 'like little tiny computer bits' – a 'sci-fi substance' known as nanobots and hydrogel which can be 'triggered

at any moment to deliver its payload' and act as 'biosensors'. The synthetic substance had 'the ability to accumulate data from your body like your breathing, your respiration, thoughts and emotions, all kind of things' and each syringe could carry a *million* nanobots:

This substance because it's like little bits of computers in your body, crazy, but it's true, it can do that, [and] obviously has the ability to act through Wi-Fi. It can receive and transmit energy, messages, frequencies or impulses. That issue has never been addressed by these companies. What does that do to the human?

Just imagine getting this substance in you and it can react to things all around you, the 5G, your smart device, your phones, what is happening with that? What if something is triggering it, too, like an impulse, a frequency? We have something completely foreign in the human body.

Madej said her research revealed that electromagnetic (EMF) frequencies emitted by phones and other devices had increased dramatically in the same period of the 'vaccine' rollout and she was seeing more people with radiation problems as 5G and other electromagnetic technology was expanded and introduced to schools and hospitals. She said she was 'floored with the EMF coming off' the devices she checked. All this makes total sense and syncs with my own work of decades when you think that Moderna refers in documents to its mRNA 'vaccine' as an 'operating system':

Recognizing the broad potential of mRNA science, we set out to create an mRNA technology platform that functions very much like an operating system on a computer. It is designed so that it can plug and play interchangeably with different programs. In our case, the 'program' or 'app' is our mRNA drug – the unique mRNA sequence that codes for a protein ...

... Our MRNA Medicines – 'The 'Software Of Life': When we have a concept for a new mRNA medicine and begin research, fundamental components are already in place. Generally, the only thing that changes from one potential mRNA medicine to another is the coding region – the actual genetic code that instructs ribosomes to make protein. Utilizing these instruction sets gives our investigational mRNA medicines a software-like quality. We also have the ability to combine different mRNA sequences encoding for different proteins in a single mRNA investigational medicine.

Who needs a real 'virus' when you can create a computer version to justify infusing your operating system into the entire human race on the road to making living, breathing people into cyborgs? What is missed with the 'vaccines' is the *digital* connection between synthetic material and the body that I highlighted earlier with the study that hacked a computer with human DNA. On one level the body is digital, based on mathematical codes, and I'll have more about that in the next chapter. Those who ridiculously claim that mRNA 'vaccines' are not designed to change human genetics should explain the words of Dr Tal Zaks, chief medical officer at Moderna, in a 2017 TED talk. He said that over the last 30 years 'we've been living this phenomenal digital scientific revolution, and I'm here today to tell you, that we are actually *hacking the software of life*, and that it's changing the way we think about prevention and treatment of disease':

In every cell there's this thing called messenger RNA, or mRNA for short, that transmits the critical information from the DNA in our genes to the protein, which is really the stuff we're all made out of. This is the critical information that determines what the cell will do. So we think about it as an operating system. So if you could change that, if you could introduce a line of code, or change a line of code, it turns out, that has profound implications for everything, from the flu to cancer.

Zaks should more accurately have said that this has profound implications for the human genetic code and the nature of DNA. Communications within the body go both ways and not only one. But, hey, no, the 'Covid vaccine' will not affect your genetics. Cult fact-checkers say so even though the man who helped to develop the mRNA technique says that it does. Zaks said in 2017:

If you think about what it is we're trying to do. We've taken information and our understanding of that information and how that information is transmitted in a cell, and we've taken our understanding of medicine and how to make drugs, and we're fusing the two. We think of it as information therapy.

I have been writing for decades that the body is an information field communicating with itself and the wider world. This is why

radiation which is information can change the information field of body and mind through phenomena like 5G and change their nature and function. 'Information therapy' means to change the body's information field and change the way it operates. DNA is a receiver-transmitter of information and can be mutated by information like mRNA synthetic messaging. Technology to do this has been ready and waiting in the underground bases and other secret projects to be rolled out when the 'Covid' hoax was played. 'Trials' of such short and irrelevant duration were only for public consumption. When they say the 'vaccine' is 'experimental' that is not true. It may appear to be 'experimental' to those who don't know what's going on, but the trials have already been done to ensure the Cult gets the result it desires. Zaks said that it took decades to sequence the human genome, completed in 2003, but now they could do it in a week. By 'they' he means scientists operating in the public domain. In the secret projects they were sequencing the genome in a week long before even 2003.

## **Deluge of mRNA**

Highly significantly the Moderna document says the guiding premise is that if using mRNA as a medicine works for one disease then it should work for many diseases. They were leveraging the flexibility afforded by their platform and the fundamental role mRNA plays in protein synthesis to pursue mRNA medicines for a broad spectrum of diseases. Moderna is confirming what I was saying through 2020 that multiple 'vaccines' were planned for 'Covid' (and later invented 'variants') and that previous vaccines would be converted to the mRNA system to infuse the body with massive amounts of genetically-manipulating synthetic material to secure a transformation to a synthetic-biological state. The 'vaccines' are designed to kill stunning numbers as part of the long-exposed Cult depopulation agenda and transform the rest. Given this is the goal you can appreciate why there is such hysterical demand for every human to be 'vaccinated' for an alleged 'disease' that has an estimated 'infection' to 'death' ratio of 0.23-0.15 percent. As I write

children are being given the 'vaccine' in trials (their parents are a disgrace) and ever-younger people are being offered the vaccine for a 'virus' that even if you believe it exists has virtually zero chance of harming them. Horrific effects of the 'trials' on a 12-year-old girl were revealed by a family member to be serious brain and gastric problems that included a bowel obstruction and the inability to swallow liquids or solids. She was unable to eat or drink without throwing up, had extreme pain in her back, neck and abdomen, and was paralysed from the waist down which stopped her urinating unaided. When the girl was first taken to hospital doctors said it was all in her mind. She was signed up for the 'trial' by her parents for whom no words suffice. None of this 'Covid vaccine' insanity makes any sense unless you see what the 'vaccine' really is – a body-changer. Synthetic biology or 'SynBio' is a fast-emerging and expanding scientific discipline which includes everything from genetic and molecular engineering to electrical and computer engineering. Synthetic biology is defined in these ways:

- A multidisciplinary area of research that seeks to create new biological parts, devices, and systems, or to redesign systems that are already found in nature.
- The use of a mixture of physical engineering and genetic engineering to create new (and therefore synthetic) life forms.
- An emerging field of research that aims to combine the knowledge and methods of biology, engineering and related disciplines in the design of chemically-synthesized DNA to create organisms with novel or enhanced characteristics and traits (synthetic organisms including humans).

We now have synthetic blood, skin, organs and limbs being developed along with synthetic body parts produced by 3D printers. These are all elements of the synthetic human programme and this comment by Kurzweil's co-founder of the Singularity University,

Peter Diamandis, can be seen in a whole new light with the 'Covid' hoax and the sanctions against those that refuse the 'vaccine':

Anybody who is going to be resisting the progress forward [to transhumanism] is going to be resisting evolution and, fundamentally, they will die out. It's not a matter of whether it's good or bad. It's going to happen.

'Resisting evolution'? What absolute bollocks. The arrogance of these people is without limit. His 'it's going to happen' mantra is another way of saying 'resistance is futile' to break the spirit of those pushing back and we must not fall for it. Getting this genetically-transforming 'vaccine' into everyone is crucial to the Cult plan for total control and the desperation to achieve that is clear for anyone to see. Vaccine passports are a major factor in this and they, too, are a form of resistance is futile. It's NOT. The paper funded by the Rockefeller Foundation for the 2013 'health conference' in China said:

We will interact more with artificial intelligence. The use of robotics, bio-engineering to augment human functioning is already well underway and will advance. Re-engineering of humans into potentially separate and unequal forms through genetic engineering or mixed human-robots raises debates on ethics and equality.

A new demography is projected to emerge after 2030 [that year again] of technologies (robotics, genetic engineering, nanotechnology) producing robots, engineered organisms, 'nanobots' and artificial intelligence (AI) that can self-replicate. Debates will grow on the implications of an impending reality of human designed life.

What is happening today is so long planned. The world army enforcing the will of the world government is intended to be a robot army, not a human one. Today's military and its technologically 'enhanced' troops, pilotless planes and driverless vehicles are just stepping stones to that end. Human soldiers are used as Cult fodder and its time they woke up to that and worked for the freedom of the population instead of their own destruction and their family's destruction – the same with the police. Join us and let's sort this out. The phenomenon of enforce my own destruction is widespread in the 'Covid' era with Woker 'luvvies' in the acting and entertainment

industries supporting 'Covid' rules which have destroyed their profession and the same with those among the public who put signs on the doors of their businesses 'closed due to Covid – stay safe' when many will never reopen. It's a form of masochism and most certainly insanity.

## **Transgender = transhumanism**

When something explodes out of nowhere and is suddenly everywhere it is always the Cult agenda and so it is with the tidal wave of claims and demands that have infiltrated every aspect of society under the heading of 'transgenderism'. The term 'trans' is so 'in' and this is the dictionary definition:

A prefix meaning 'across', 'through', occurring ... in loanwords from Latin, used in particular for denoting movement or conveyance from place to place (transfer; transmit; transplant) or complete change (transform; transmute), or to form adjectives meaning 'crossing', 'on the other side of', or 'going beyond' the place named (transmontane; transnational; trans-Siberian).

Transgender means to go beyond gender and transhuman means to go beyond human. Both are aspects of the Cult plan to transform the human body to a synthetic state with *no gender*. Human 2.0 is not designed to procreate and would be produced technologically with no need for parents. The new human would mean the end of parents and so men, and increasingly women, are being targeted for the deletion of their rights and status. Parental rights are disappearing at an ever-quickenning speed for the same reason. The new human would have no need for men or women when there is no procreation and no gender. Perhaps the transgender movement that appears to be in a permanent state of frenzy might now contemplate on how it is being used. This was never about transgender rights which are only the interim excuse for confusing gender, particularly in the young, on the road to *fusing* gender. Transgender activism is not an end; it is a *means* to an end. We see again the technique of creative destruction in which you destroy the status quo to 'build back better' in the form that you want. The gender status quo had to be

destroyed by persuading the Cult-created Woke mentality to believe that you can have 100 genders or more. A programme for 9 to 12 year olds produced by the Cult-owned BBC promoted the 100 genders narrative. The very idea may be the most monumental nonsense, but it is not what is true that counts, only what you can make people *believe* is true. Once the gender of  $2 + 2 = 4$  has been dismantled through indoctrination, intimidation and  $2 + 2 = 5$  then the new no-gender normal can take its place with Human 2.0.

Aldous Huxley revealed the plan in his prophetic *Brave New World* in 1932:

Natural reproduction has been done away with and children are created, decanted', and raised in 'hatcheries and conditioning centres'. From birth, people are genetically designed to fit into one of five castes, which are further split into 'Plus' and 'Minus' members and designed to fulfil predetermined positions within the social and economic strata of the World State.

How could Huxley know this in 1932? For the same reason George Orwell knew about the Big Brother state in 1948, Cult insiders I have quoted knew about it in 1969, and I have known about it since the early 1990s. If you are connected to the Cult or you work your balls off to uncover the plan you can predict the future. The process is simple. If there is a plan for the world and nothing intervenes to stop it then it will happen. Thus if you communicate the plan ahead of time you are perceived to have predicted the future, but you haven't. You have revealed the plan which without intervention will become the human future. The whole reason I have done what I have is to alert enough people to inspire an intervention and maybe at last that time has come with the Cult and its intentions now so obvious to anyone with a brain in working order.

## **The future is here**

Technological wombs that Huxley described to replace parent procreation are already being developed and they are only the projects we know about in the public arena. Israeli scientists told *The Times of Israel* in March, 2021, that they have grown 250-cell embryos



into mouse fetuses with fully formed organs using artificial wombs in a development they say could pave the way for gestating humans outside the womb. Professor Jacob Hanna of the Weizmann Institute of Science said:

We took mouse embryos from the mother at day five of development, when they are just of 250 cells, and had them in the incubator from day five until day 11, by which point they had grown all their organs.

By day 11 they make their own blood and have a beating heart, a fully developed brain. Anybody would look at them and say, 'this is clearly a mouse foetus with all the characteristics of a mouse.' It's gone from being a ball of cells to being an advanced foetus.

A special liquid is used to nourish embryo cells in a laboratory dish and they float on the liquid to duplicate the first stage of embryonic development. The incubator creates all the right conditions for its development, Hanna said. The liquid gives the embryo 'all the nutrients, hormones and sugars they need' along with a custom-made electronic incubator which controls gas concentration, pressure and temperature. The cutting-edge in the underground bases and other secret locations will be light years ahead of that, however, and this was reported by the London *Guardian* in 2017:

We are approaching a biotechnological breakthrough. Ectogenesis, the invention of a complete external womb, could completely change the nature of human reproduction. In April this year, researchers at the Children's Hospital of Philadelphia announced their development of an artificial womb.

The article was headed 'Artificial wombs could soon be a reality. What will this mean for women?' What would it mean for children is an even bigger question. No mother to bond with only a machine in preparation for a life of soulless interaction and control in a world governed by machines (see the *Matrix* movies). Now observe the calculated manipulations of the 'Covid' hoax as human interaction and warmth has been curtailed by distancing, isolation and fear with people communicating via machines on a scale never seen before.

These are all dots in the same picture as are all the personal assistants, gadgets and children's toys through which kids and adults communicate with AI as if it is human. The AI 'voice' on Sat-Nav should be included. All these things are psychological preparation for the Cult endgame. Before you can make a physical connection with AI you have to make a psychological connection and that is what people are being conditioned to do with this ever gathering human-AI interaction. Movies and TV programmes depicting the transhuman, robot dystopia relate to a phenomenon known as 'pre-emptive programming' in which the world that is planned is portrayed everywhere in movies, TV and advertising. This is conditioning the conscious and subconscious mind to become familiar with the planned reality to dilute resistance when it happens for real. What would have been a shock such is the change is made less so. We have young children put on the road to transgender transition surgery with puberty blocking drugs at an age when they could never be able to make those life-changing decisions.

Rachel Levine, a professor of paediatrics and psychiatry who believes in treating children this way, became America's highest-ranked openly-transgender official when she was confirmed as US Assistant Secretary at the Department of Health and Human Services after being nominated by Joe Biden (the Cult). Activists and governments press for laws to deny parents a say in their children's transition process so the kids can be isolated and manipulated into agreeing to irreversible medical procedures. A Canadian father Robert Hoogland was denied bail by the Vancouver Supreme Court in 2021 and remained in jail for breaching a court order that he stay silent over his young teenage daughter, a minor, who was being offered life-changing hormone therapy without parental consent. At the age of 12 the girl's 'school counsellor' said she may be transgender, referred her to a doctor and told the school to treat her like a boy. This is another example of state-serving schools imposing ever more control over children's lives while parents have ever less.

Contemptible and extreme child abuse is happening all over the world as the Cult gender-fusion operation goes into warp-speed.

### **Why the war on men – and now women?**

The question about what artificial wombs mean for women should rightly be asked. The answer can be seen in the deletion of women's rights involving sport, changing rooms, toilets and status in favour of people in male bodies claiming to identify as women. I can identify as a mountain climber, but it doesn't mean I can climb a mountain any more than a biological man can be a biological woman. To believe so is a triumph of belief over factual reality which is the very perceptual basis of everything Woke. Women's sport is being destroyed by allowing those with male bodies who say they identify as female to 'compete' with girls and women. Male body 'women' dominate 'women's' competition with their greater muscle mass, bone density, strength and speed. With that disadvantage sport for women loses all meaning. To put this in perspective nearly 300 American high school boys can run faster than the quickest woman sprinter in the world. Women are seeing their previously protected spaces invaded by male bodies simply because they claim to identify as women. That's all they need to do to access all women's spaces and activities under the Biden 'Equality Act' that destroys equality for women with the usual Orwellian Woke inversion. Male sex offenders have already committed rapes in women's prisons after claiming to identify as women to get them transferred. Does this not matter to the Woke 'equality' hypocrites? Not in the least. What matters to Cult manipulators and funders behind transgender activists is to advance gender fusion on the way to the no-gender 'human'. When you are seeking to impose transparent nonsense like this, or the 'Covid' hoax, the only way the nonsense can prevail is through censorship and intimidation of dissenters, deletion of factual information, and programming of the unquestioning, bewildered and naive. You don't have to scan the world for long to see that all these things are happening.

Many women's rights organisations have realised that rights and status which took such a long time to secure are being eroded and that it is systematic. Kara Dansky of the global Women's Human Rights Campaign said that Biden's transgender executive order immediately he took office, subsequent orders, and Equality Act legislation that followed 'seek to erase women and girls in the law as a category'. *Exactly*. I said during the long ago-started war on men (in which many women play a crucial part) that this was going to turn into a war on them. The Cult is phasing out *both* male and female genders. To get away with that they are brought into conflict so they are busy fighting each other while the Cult completes the job with no unity of response. Unity, people, *unity*. We need unity everywhere. Transgender is the only show in town as the big step towards the no-gender human. It's not about rights for transgender people and never has been. Woke political correctness is deleting words relating to genders to the same end. Wokers believe this is to be 'inclusive' when the opposite is true. They are deleting words describing gender because gender *itself* is being deleted by Human 2.0. Terms like 'man', 'woman', 'mother' and 'father' are being deleted in the universities and other institutions to be replaced by the *no-gender*, not trans-gender, 'individuals' and 'guardians'. Women's rights campaigner Maria Keffler of Partners for Ethical Care said: 'Children are being taught from kindergarten upward that some boys have a vagina, some girls have a penis, and that kids can be any gender they want to be.' Do we really believe that suddenly countries all over the world at the same time had the idea of having drag queens go into schools or read transgender stories to very young children in the local library? It's coldly-calculated confusion of gender on the way to the fusion of gender. Suzanne Vierling, a psychologist from Southern California, made another important point:

Yesterday's slave woman who endured gynecological medical experiments is today's girl-child being butchered in a booming gender-transitioning sector. Ovaries removed, pushing her into menopause and osteoporosis, uncharted territory, and parents' rights and authority decimated.

The erosion of parental rights is a common theme in line with the Cult plans to erase the very concept of parents and 'ovaries removed, pushing her into menopause' means what? Those born female lose the ability to have children – another way to discontinue humanity as we know it.

### **Eliminating Human 1.0 (before our very eyes)**

To pave the way for Human 2.0 you must phase out Human 1.0. This is happening through plummeting sperm counts and making women infertile through an onslaught of chemicals, radiation (including smartphones in pockets of men) and mRNA 'vaccines'. Common agriculture pesticides are also having a devastating impact on human fertility. I have been tracking collapsing sperm counts in the books for a long time and in 2021 came a book by fertility scientist and reproductive epidemiologist Shanna Swan, *Count Down: How Our Modern World Is Threatening Sperm Counts, Altering Male and Female Reproductive Development and Imperiling the Future of the Human Race*. She reports how the global fertility rate dropped by *half* between 1960 and 2016 with America's birth rate 16 percent below where it needs to be to sustain the population. Women are experiencing declining egg quality, more miscarriages, and more couples suffer from infertility. Other findings were an increase in erectile dysfunction, infant boys developing more genital abnormalities, male problems with conception, and plunging levels of the male hormone testosterone which would explain why so many men have lost their backbone and masculinity. This has been very evident during the 'Covid' hoax when women have been prominent among the Pushbackers and big strapping blokes have bowed their heads, covered their faces with a nappy and quietly submitted. Mind control expert Cathy O'Brien also points to how global education introduced the concept of 'we're all winners' in sport and classrooms: 'Competition was defused, and it in turn defused a sense of fighting back.' This is another version of the 'equity' doctrine in which you drive down rather than raise up. What a contrast in Cult-controlled China with its global ambitions

where the government published plans in January, 2021, to 'cultivate masculinity' in boys from kindergarten through to high school in the face of a 'masculinity crisis'. A government adviser said boys would be soon become 'delicate, timid and effeminate' unless action was taken. Don't expect any similar policy in the targeted West. A 2006 study showed that a 65-year-old man in 2002 had testosterone levels *15 percent* lower than a 65-year-old man in 1987 while a 2020 study found a similar story with young adults and adolescents. Men are getting prescriptions for testosterone replacement therapy which causes an even greater drop in sperm count with up to 99 percent seeing sperm counts drop to zero during the treatment. More sperm is defective and malfunctioning with some having two heads or not pursuing an egg.

A class of *synthetic* chemicals known as phthalates are being blamed for the decline. These are found everywhere in plastics, shampoos, cosmetics, furniture, flame retardants, personal care products, pesticides, canned foods and even receipts. Why till receipts? Everyone touches them. Let no one delude themselves that all this is not systematic to advance the long-time agenda for human body transformation. Phthalates mimic hormones and disrupt the hormone balance causing testosterone to fall and genital birth defects in male infants. Animals and fish have been affected in the same way due to phthalates and other toxins in rivers. When fish turn gay or change sex through chemicals in rivers and streams it is a pointer to why there has been such an increase in gay people and the sexually confused. It doesn't matter to me what sexuality people choose to be, but if it's being affected by chemical pollution and consumption then we need to know. Does anyone really think that this is not connected to the transgender agenda, the war on men and the condemnation of male 'toxic masculinity'? You watch this being followed by 'toxic femininity'. It's already happening. When breastfeeding becomes 'chest-feeding', pregnant women become pregnant people along with all the other Woke claptrap you know that the world is going insane and there's a Cult scam in progress. Transgender activists are promoting the Cult agenda while Cult

billionaires support and fund the insanity as they laugh themselves to sleep at the sheer stupidity for which humans must be infamous in galaxies far, far away.

### **'Covid vaccines' and female infertility**

We can now see why the 'vaccine' has been connected to potential infertility in women. Dr Michael Yeadon, former Vice President and Chief Scientific Advisor at Pfizer, and Dr Wolfgang Wodarg in Germany, filed a petition with the European Medicines Agency in December, 2020, urging them to stop trials for the Pfizer/BioNTech shot and all other mRNA trials until further studies had been done. They were particularly concerned about possible effects on fertility with 'vaccine'-produced antibodies attacking the protein Syncytin-1 which is responsible for developing the placenta. The result would be infertility 'of indefinite duration' in women who have the 'vaccine' with the placenta failing to form. Section 10.4.2 of the Pfizer/BioNTech trial protocol says that pregnant women or those who might become so should not have mRNA shots. Section 10.4 warns men taking mRNA shots to 'be abstinent from heterosexual intercourse' and not to donate sperm. The UK government said that it *did not know* if the mRNA procedure had an effect on fertility. *Did not know?* These people have to go to jail. UK government advice did not recommend at the start that pregnant women had the shot and said they should avoid pregnancy for at least two months after 'vaccination'. The 'advice' was later updated to pregnant women should only have the 'vaccine' if the benefits outweighed the risks to mother and foetus. What the hell is that supposed to mean? Then 'spontaneous abortions' began to appear and rapidly increase on the adverse reaction reporting schemes which include only a fraction of adverse reactions. Thousands and ever-growing numbers of 'vaccinated' women are describing changes to their menstrual cycle with heavier blood flow, irregular periods and menstruating again after going through the menopause – all links to reproduction effects. Women are passing blood clots and the lining of their uterus while men report erectile dysfunction and blood effects. Most

significantly of all *unvaccinated* women began to report similar menstrual changes after interaction with '*vaccinated*' people and men and children were also affected with bleeding noses, blood clots and other conditions. 'Shedding' is when vaccinated people can emit the content of a vaccine to affect the unvaccinated, but this is different. 'Vaccinated' people were not shedding a 'live virus' allegedly in 'vaccines' as before because the fake 'Covid vaccines' involve synthetic material and other toxicity. Doctors exposing what is happening prefer the term 'transmission' to shedding. Somehow those that have had the shots are transmitting effects to those that haven't. Dr Carrie Madej said the nano-content of the 'vaccines' can 'act like an antenna' to others around them which fits perfectly with my own conclusions. This 'vaccine' transmission phenomenon was becoming known as the book went into production and I deal with this further in the Postscript.

Vaccine effects on sterility are well known. The World Health Organization was accused in 2014 of sterilising millions of women in Kenya with the evidence confirmed by the content of the vaccines involved. The same WHO behind the 'Covid' hoax admitted its involvement for more than ten years with the vaccine programme. Other countries made similar claims. Charges were lodged by Tanzania, Nicaragua, Mexico, and the Philippines. The Gardasil vaccine claimed to protect against a genital 'virus' known as HPV has also been linked to infertility. Big Pharma and the WHO (same thing) are criminal and satanic entities. Then there's the Bill Gates Foundation which is connected through funding and shared interests with 20 pharmaceutical giants and laboratories. He stands accused of directing the policy of United Nations Children's Fund (UNICEF), vaccine alliance GAVI, and other groupings, to advance the vaccine agenda and silence opposition at great cost to women and children. At the same time Gates wants to reduce the global population. Coincidence?

**Great Reset = Smart Grid = new human**



The Cult agenda I have been exposing for 30 years is now being openly promoted by Cult assets like Gates and Klaus Schwab of the World Economic Forum under code-terms like the 'Great Reset', 'Build Back Better' and 'a rare but narrow window of opportunity to reflect, reimagine, and reset our world'. What provided this 'rare but narrow window of opportunity'? The 'Covid' hoax did. Who created that? *They* did. My books from not that long ago warned about the planned 'Internet of Things' (IoT) and its implications for human freedom. This was the plan to connect all technology to the Internet and artificial intelligence and today we are way down that road with an estimated 36 billion devices connected to the World Wide Web and that figure is projected to be 76 billion by 2025. I further warned that the Cult planned to go beyond that to the Internet of *Everything* when the human brain was connected via AI to the Internet and Kurzweil's 'cloud'. Now we have Cult operatives like Schwab calling for precisely that under the term 'Internet of Bodies', a fusion of the physical, digital and biological into one centrally-controlled Smart Grid system which the Cult refers to as the 'Fourth Industrial Revolution'. They talk about the 'biological', but they really mean the synthetic-biological which is required to fully integrate the human body and brain into the Smart Grid and artificial intelligence planned to replace the human mind. We have everything being synthetically manipulated including the natural world through GMO and smart dust, the food we eat and the human body itself with synthetic 'vaccines'. I said in *The Answer* that we would see the Cult push for synthetic meat to replace animals and in February, 2021, the so predictable psychopath Bill Gates called for the introduction of synthetic meat to save us all from 'climate change'. The climate hoax just keeps on giving like the 'Covid' hoax. The war on meat by vegan activists is a carbon (oops, sorry) copy of the manipulation of transgender activists. They have no idea (except their inner core) that they are being used to promote and impose the agenda of the Cult or that they are only the *vehicle* and not the *reason*. This is not to say those who choose not to eat meat shouldn't be respected and supported in that right, but there are ulterior motives

for those in power. A *Forbes* article in December, 2019, highlighted the plan so beloved of Schwab and the Cult under the heading: 'What Is The Internet of Bodies? And How Is It Changing Our World?' The article said the human body is the latest data platform (remember 'our vaccine is an operating system'). *Forbes* described the plan very accurately and the words could have come straight out of my books from long before:

The Internet of Bodies (IoB) is an extension of the IoT and basically connects the human body to a network through devices that are ingested, implanted, or connected to the body in some way. Once connected, data can be exchanged, and the body and device can be remotely monitored and controlled.

They were really describing a human hive mind with human perception centrally-dictated via an AI connection as well as allowing people to be 'remotely monitored and controlled'. Everything from a fridge to a human mind could be directed from a central point by these insane psychopaths and 'Covid vaccines' are crucial to this. *Forbes* explained the process I mentioned earlier of holdable and wearable technology followed by implantable. The article said there were three generations of the Internet of Bodies that include:

- Body external: These are wearable devices such as Apple Watches or Fitbits that can monitor our health.
- Body internal: These include pacemakers, cochlear implants, and digital pills that go inside our bodies to monitor or control various aspects of health.
- Body embedded: The third generation of the Internet of Bodies is embedded technology where technology and the human body are melded together and have a real-time connection to a remote machine.

*Forbes* noted the development of the Brain Computer Interface (BCI) which merges the brain with an external device for monitoring and controlling in real-time. 'The ultimate goal is to help restore function to individuals with disabilities by using brain signals rather than conventional neuromuscular pathways.' Oh, do fuck off. The goal of brain interface technology is controlling human thought and emotion from the central point in a hive mind serving its masters wishes. Many people are now agreeing to be chipped to open doors without a key. You can recognise them because they'll be wearing a mask, social distancing and lining up for the 'vaccine'. The Cult plans a Great Reset money system after they have completed the demolition of the global economy in which 'money' will be exchanged through communication with body operating systems. Rand Corporation, a Cult-owned think tank, said of the Internet of Bodies or IoB:

Internet of Bodies technologies fall under the broader IoT umbrella. But as the name suggests, IoB devices introduce an even more intimate interplay between humans and gadgets. IoB devices monitor the human body, collect health metrics and other personal information, and transmit those data over the Internet. Many devices, such as fitness trackers, are already in use ... IoB devices ... and those in development can track, record, and store users' whereabouts, bodily functions, and what they see, hear, and even think.

Schwab's World Economic Forum, a long-winded way of saying 'fascism' or 'the Cult', has gone full-on with the Internet of Bodies in the 'Covid' era. 'We're entering the era of the Internet of Bodies', it declared, 'collecting our physical data via a range of devices that can be implanted, swallowed or worn'. The result would be a huge amount of health-related data that could improve human wellbeing around the world, and prove crucial in fighting the 'Covid-19 pandemic'. Does anyone think these clowns care about 'human wellbeing' after the death and devastation their pandemic hoax has purposely caused? Schwab and co say we should move forward with the Internet of Bodies because 'Keeping track of symptoms could help us stop the spread of infection, and quickly detect new cases'. How wonderful, but keeping track' is all they are really bothered

about. Researchers were investigating if data gathered from smartwatches and similar devices could be used as viral infection alerts by tracking the user's heart rate and breathing. Schwab said in his 2018 book *Shaping the Future of the Fourth Industrial Revolution*:

The lines between technologies and beings are becoming blurred and not just by the ability to create lifelike robots or synthetics. Instead it is about the ability of new technologies to literally become part of us. Technologies already influence how we understand ourselves, how we think about each other, and how we determine our realities. As the technologies ... give us deeper access to parts of ourselves, we may begin to integrate digital technologies into our bodies.

You can see what the game is. Twenty-four hour control and people – if you could still call them that – would never know when something would go ping and take them out of circulation. It's the most obvious rush to a global fascist dictatorship and the complete submission of humanity and yet still so many are locked away in their Cult-induced perceptual coma and can't see it.

### **Smart Grid control centres**

The human body is being transformed by the 'vaccines' and in other ways into a synthetic cyborg that can be attached to the global Smart Grid which would be controlled from a central point and other sub-locations of Grid manipulation. Where are these planned to be? Well, China for a start which is one of the Cult's biggest centres of operation. The technological control system and technocratic rule was incubated here to be unleashed across the world after the 'Covid' hoax came out of China in 2020. Another Smart Grid location that will surprise people new to this is Israel. I have exposed in *The Trigger* how Sabbatian technocrats, intelligence and military operatives were behind the horrors of 9/11 and not 19 Arab hijackers' who somehow manifested the ability to pilot big passenger airliners when instructors at puddle-jumping flying schools described some of them as a joke. The 9/11 attacks were made possible through control of civilian and military air computer systems and those of the White House, Pentagon and connected agencies. See *The Trigger* – it

will blow your mind. The controlling and coordinating force were the Sabbatian networks in Israel and the United States which by then had infiltrated the entire US government, military and intelligence system. The real name of the American Deep State is 'Sabbatian State'. Israel is a tiny country of only nine million people, but it is one of the global centres of cyber operations and fast catching Silicon Valley in importance to the Cult. Israel is known as the 'start-up nation' for all the cyber companies spawned there with the Sabbatian specialisation of 'cyber security' that I mentioned earlier which gives those companies access to computer systems of their clients in real time through 'backdoors' written into the coding when security software is downloaded. The Sabbatian centre of cyber operations outside Silicon Valley is the Israeli military Cyber Intelligence Unit, the biggest infrastructure project in Israel's history, headquartered in the desert-city of Beersheba and involving some 20,000 'cyber soldiers'. Here are located a literal army of Internet trolls scanning social media, forums and comment lists for anyone challenging the Cult agenda. The UK military has something similar with its 77th Brigade and associated operations. The Beersheba complex includes research and development centres for other Cult operations such as Intel, Microsoft, IBM, Google, Apple, Hewlett-Packard, Cisco Systems, Facebook and Motorola. [Techcrunch.com](http://Techcrunch.com) ran an article about the Beersheba global Internet technology centre headlined 'Israel's desert city of Beersheba is turning into a cybertech oasis':

The military's massive relocation of its prestigious technology units, the presence of multinational and local companies, a close proximity to Ben Gurion University and generous government subsidies are turning Beersheba into a major global cybertech hub. Beersheba has all of the ingredients of a vibrant security technology ecosystem, including Ben Gurion University with its graduate program in cybersecurity and Cyber Security Research Center, and the presence of companies such as EMC, Deutsche Telekom, PayPal, Oracle, IBM, and Lockheed Martin. It's also the future home of the INCB (Israeli National Cyber Bureau); offers a special income tax incentive for cyber security companies, and was the site for the relocation of the army's intelligence corps units.

Sabbatians have taken over the cyber world through the following process: They scan the schools for likely cyber talent and develop them at Ben Gurion University and their period of conscription in the Israeli Defense Forces when they are stationed at the Beersheba complex. When the cyber talented officially leave the army they are funded to start cyber companies with technology developed by themselves or given to them by the state. Much of this is stolen through backdoors of computer systems around the world with America top of the list. Others are sent off to Silicon Valley to start companies or join the major ones and so we have many major positions filled by apparently 'Jewish' but really Sabbatian operatives. Google, YouTube and Facebook are all run by 'Jewish' CEOs while Twitter is all but run by ultra-Zionist hedge-fund shark Paul Singer. At the centre of the Sabbatian global cyber web is the Israeli army's Unit 8200 which specialises in hacking into computer systems of other countries, inserting viruses, gathering information, instigating malfunction, and even taking control of them from a distance. A long list of Sabbatians involved with 9/11, Silicon Valley and Israeli cyber security companies are operatives of Unit 8200. This is not about Israel. It's about the Cult. Israel is planned to be a Smart Grid hub as with China and what is happening at Beersheba is not for the benefit of Jewish people who are treated disgustingly by the Sabbatian elite that control the country. A glance at the Nuremberg Codes will tell you that.

The story is much bigger than 'Covid', important as that is to where we are being taken. Now, though, it's time to really strap in. There's more ... much more ...

## CHAPTER ELEVEN

### Who controls the Cult?

*Awake, arise or be forever fall'n*  
John Milton, *Paradise Lost*

I have exposed this far the level of the Cult conspiracy that operates in the world of the seen and within the global secret society and satanic network which operates in the shadows one step back from the seen. The story, however, goes much deeper than that.

The 'Covid' hoax is major part of the Cult agenda, but only part, and to grasp the biggest picture we have to expand our attention beyond the realm of human sight and into the infinity of possibility that we cannot see. It is from here, ultimately, that humanity is being manipulated into a state of total control by the force which dictates the actions of the Cult. How much of reality can we see? Next to damn all is the answer. We may appear to see all there is to see in the 'space' our eyes survey and observe, but little could be further from the truth. The human 'world' is only a tiny band of frequency that the body's visual and perceptual systems can decode into *perception* of a 'world'. According to mainstream science the electromagnetic spectrum is 0.005 percent of what exists in the Universe (Fig 10). The maximum estimate I have seen is 0.5 percent and either way it's miniscule. I say it is far, far, smaller even than 0.005 percent when you compare reality we see with the totality of reality that we don't. Now get this if you are new to such information: Visible light, the only band of frequency that we can see, is a *fraction* of the 0.005

percent (Fig 11 overleaf). Take this further and realise that our universe is one of infinite universes and that universes are only a fragment of overall reality – *infinite* reality. Then compare that with the almost infinitesimal frequency band of visible light or human sight. You see that humans are as near blind as it is possible to be without actually being so. Artist and filmmaker, Sergio Toporek, said:

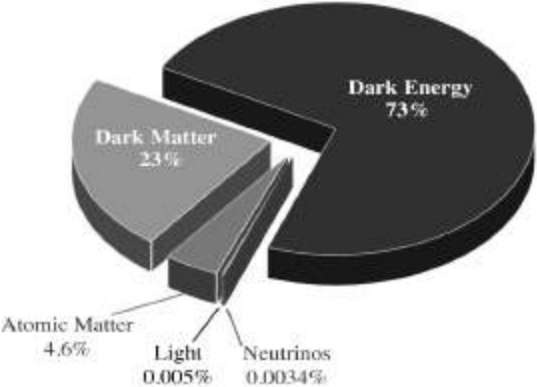


Figure 10: Humans can perceive such a tiny band of visual reality it's laughable.

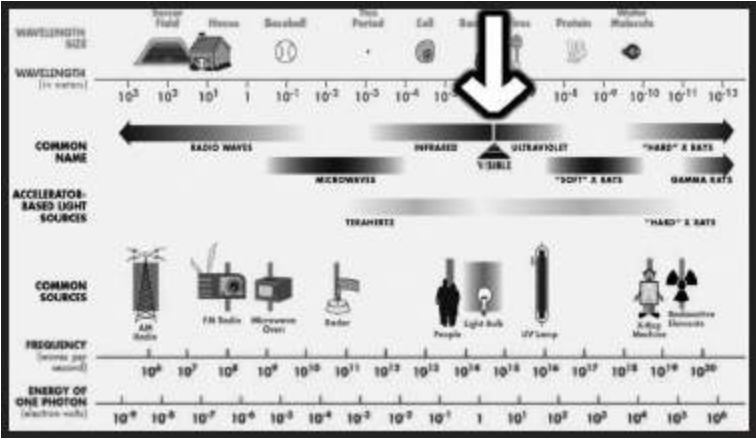


Figure 11: We can see a smear of the 0.005 percent electromagnetic spectrum, but we still know it all. Yep, makes sense.

Consider that you can see less than 1% of the electromagnetic spectrum and hear less than 1% of the acoustic spectrum. 90% of the cells in your body carry their own microbial DNA and are not 'you'. The atoms in your body are 99.9999999999999999% empty space and none of them are the ones you were born with ... Human beings have 46 chromosomes, two less than a potato.



The existence of the rainbow depends on the conical photoreceptors in your eyes; to animals without cones, the rainbow does not exist. So you don't just look at a rainbow, you create it. This is pretty amazing, especially considering that all the beautiful colours you see represent less than 1% of the electromagnetic spectrum.

Suddenly the 'world' of humans looks a very different place. Take into account, too, that Planet Earth when compared with the projected size of this single universe is the equivalent of a billionth of a pinhead. Imagine the ratio that would be when compared to infinite reality. To think that Christianity once insisted that Earth and humanity were the centre of everything. This background is vital if we are going to appreciate the nature of 'human' and how we can be manipulated by an unseen force. To human visual reality virtually *everything* is unseen and yet the prevailing perception within the institutions and so much of the public is that if we can't see it, touch it, hear it, taste it and smell it then it cannot exist. Such perception is indoctrinated and encouraged by the Cult and its agents because it isolates believers in the strictly limited, village-idiot, realm of the five senses where perceptions can be firewalled and information controlled. Most of those perpetuating the 'this-world-is-all-there-is' insanity are themselves indoctrinated into believing the same delusion. While major players and influencers know that official reality is laughable most of those in science, academia and medicine really believe the nonsense they peddle and teach succeeding generations. Those who challenge the orthodoxy are dismissed as nutters and freaks to protect the manufactured illusion from exposure. Observe the dynamic of the 'Covid' hoax and you will see how that takes the same form. The inner-circle psychopaths knows it's a gigantic scam, but almost the entirety of those imposing their fascist rules believe that 'Covid' is all that they're told it is.

## **Stolen identity**

Ask people who they are and they will give you their name, place of birth, location, job, family background and life story. Yet that is not who they are – it is what they are *experiencing*. The difference is *absolutely crucial*. The true 'I', the eternal, infinite 'I', is consciousness,

a state of being aware. Forget 'form'. That is a vehicle for a brief experience. Consciousness does not come *from* the brain, but *through* the brain and even that is more symbolic than literal. We are awareness, pure awareness, and this is what withdraws from the body at what we call 'death' to continue our eternal beingness, *isness*, in other realms of reality within the limitlessness of infinity or the Biblical 'many mansions in my father's house'. Labels of a human life, man, woman, transgender, black, white, brown, nationality, circumstances and income are not who we are. They are what we are – awareness – is *experiencing* in a brief connection with a band of frequency we call 'human'. The labels are not the self; they are, to use the title of one of my books, a *Phantom Self*. I am not David Icke born in Leicester, England, on April 29th, 1952. I am the consciousness *having that experience*. The Cult and its non-human masters seek to convince us through the institutions of 'education', science, medicine, media and government that what we are *experiencing* is who we *are*. It's so easy to control and direct perception locked away in the bewildered illusions of the five senses with no expanded radar. Try, by contrast, doing the same with a humanity aware of its true self and its true power to consciously create its reality and experience. How is it possible to do this? We do it all day every day. If you perceive yourself as 'little me' with no power to impact upon your life and the world then your life experience will reflect that. You will hand the power you don't think you have to authority in all its forms which will use it to control your experience. This, in turn, will appear to confirm your perception of 'little me' in a self-fulfilling feedback loop. But that is what 'little me' really is – a *perception*. We are all 'big-me', infinite me, and the Cult has to make us forget that if its will is to prevail. We are therefore manipulated and pressured into self-identifying with human labels and not the consciousness/awareness *experiencing* those human labels.

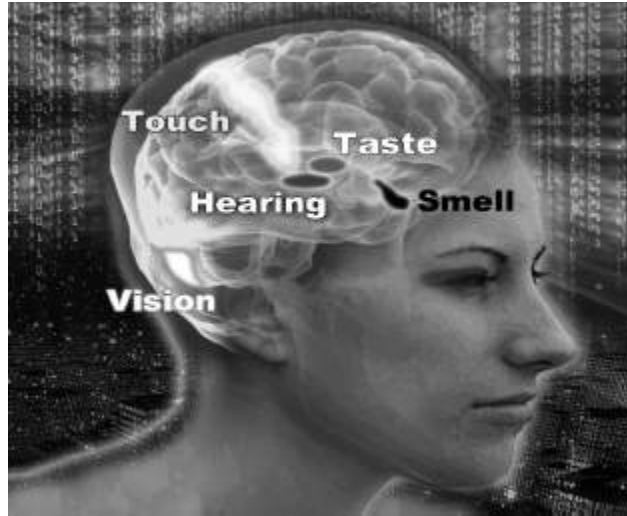
The phenomenon of identity politics is a Cult-instigated manipulation technique to sub-divide previous labels into even smaller ones. A United States university employs this list of letters to

describe student identity: LGBTTQQFAGPBDSM or lesbian, gay, bisexual, transgender, transsexual, queer, questioning, flexual, asexual, gender-fuck, polyamorous, bondage/discipline, dominance/submission and sadism/masochism. I'm sure other lists are even longer by now as people feel the need to self-identity the 'I' with the minutiae of race and sexual preference. Wokers programmed by the Cult for generations believe this is about 'inclusivity' when it's really the Cult locking them away into smaller and smaller versions of Phantom Self while firewalling them from the influence of their true self, the infinite, eternal 'I'. You may notice that my philosophy which contends that we are all unique points of attention/awareness within the same infinite whole or Oneness is the ultimate non-racism. The very sense of Oneness makes the judgement of people by their body-type, colour or sexuality utterly ridiculous and confirms that racism has no understanding of reality (including anti-white racism). Yet despite my perception of life Cult agents and fast-asleep Wokers label me racist to discredit my information while they are themselves phenomenally racist and sexist. All they see is race and sexuality and they judge people as good or bad, demons or untouchables, by their race and sexuality. All they see is *Phantom Self* and perceive themselves in terms of Phantom Self. They are pawns and puppets of the Cult agenda to focus attention and self-identity in the five senses and play those identities against each other to divide and rule. Columbia University has introduced segregated graduations in another version of social distancing designed to drive people apart and teach them that different racial and cultural groups have nothing in common with each other. The last thing the Cult wants is unity. Again the pump-primers of this will be Cult operatives in the knowledge of what they are doing, but the rest are just the Phantom Self blind leading the Phantom Self blind. We *do* have something in common – we are all *the same consciousness* having different temporary experiences.

## **What is this 'human'?**

Yes, what *is* 'human'? That is what we are supposed to be, right? I mean 'human'? True, but 'human' is the experience not the 'I'. Break it down to basics and 'human' is the way that information is processed. If we are to experience and interact with this band of frequency we call the 'world' we must have a vehicle that operates within that band of frequency. Our consciousness in its prime form cannot do that; it is way beyond the frequency of the human realm. My consciousness or awareness could not tap these keys and pick up the cup in front of me in the same way that radio station A cannot interact with radio station B when they are on different frequencies. The human body is the means through which we have that interaction. I have long described the body as a biological computer which processes information in a way that allows consciousness to experience this reality. The body is a receiver, transmitter and processor of information in a particular way that we call human. We visually perceive only the world of the five senses in a wakened state – that is the limit of the body's visual decoding system. In truth it's not even visual in the way we experience 'visual reality' as I will come to in a moment. We are 'human' because the body processes the information sources of human into a reality and behaviour system that we *perceive* as human. Why does an elephant act like an elephant and not like a human or a duck? The elephant's biological computer is a different information field and processes information according to that program into a visual and behaviour type we call an elephant. The same applies to everything in our reality. These body information fields are perpetuated through procreation (like making a copy of a software program). The Cult wants to break that cycle and intervene technologically to transform the human information field into one that will change what we call humanity. If it can change the human information field it will change the way that field processes information and change humanity both 'physically' and psychologically. Hence the *messenger* (information) RNA 'vaccines' and so much more that is targeting human genetics by changing the body's information – *messaging* – construct through food, drink, radiation, toxicity and other means.

Reality that we experience is nothing like reality as it really is in the same way that the reality people experience in virtual reality games is not the reality they are really living in. The game is only a decoded source of information that appears to be a reality. Our world is also an information construct – a *simulation* (more later). In its base form our reality is a wavefield of information much the same in theme as Wi-Fi. The five senses decode wavefield information into electrical information which they communicate to the brain to decode into holographic (illusory ‘physical’) information. Different parts of the brain specialise in decoding different senses and the information is fused into a reality that appears to be outside of us but is really inside the brain and the genetic structure in general (Fig 12 overleaf). DNA is a receiver-transmitter of information and a vital part of this decoding process and the body’s connection to other realities. Change DNA and you change the way we decode and connect with reality – see ‘Covid vaccines’. Think of computers decoding Wi-Fi. You have information encoded in a radiation field and the computer decodes that information into a very different form on the screen. You can’t see the Wi-Fi until its information is made manifest on the screen and the information on the screen is inside the computer and not outside. I have just described how we decode the ‘human world’. All five senses decode the waveform ‘Wi-Fi’ field into electrical signals and the brain (computer) constructs reality inside the brain and not outside – ‘You don’t just look at a rainbow, you create it’. Sound is a simple example. We don’t hear sound until the brain decodes it. Waveform sound waves are picked up by the hearing sense and communicated to the brain in an electrical form to be decoded into the sounds that we hear. Everything we hear is inside the brain along with everything we see, feel, smell and taste. Words and language are waveform fields generated by our vocal chords which pass through this process until they are decoded by the brain into words that we hear. Different languages are different frequency fields or sound waves generated by vocal chords. Late British philosopher Alan Watts said:



**Figure 12:** The brain receives information from the five senses and constructs from that our perceived reality.

[Without the brain] the world is devoid of light, heat, weight, solidity, motion, space, time or any other imaginable feature. All these phenomena are interactions, or transactions, of vibrations with a certain arrangement of neurons.

That's exactly what they are and scientist Robert Lanza describes in his book, *Biocentrism*, how we decode electromagnetic waves and energy into visual and 'physical' experience. He uses the example of a flame emitting photons, electromagnetic energy, each pulsing electrically and magnetically:

... these ... invisible electromagnetic waves strike a human retina, and if (and only if) the waves happen to measure between 400 and 700 nano meters in length from crest to crest, then their energy is just right to deliver a stimulus to the 8 million cone-shaped cells in the retina.

Each in turn send an electrical pulse to a neighbour neuron, and on up the line this goes, at 250 mph, until it reaches the ... occipital lobe of the brain, in the back of the head. There, a cascading complex of neurons fire from the incoming stimuli, and we subjectively perceive this experience as a yellow brightness occurring in a place we have been conditioned to call the 'external world'.

**You hear what you decode**

If a tree falls or a building collapses they make no noise unless someone is there to decode the energetic waves generated by the disturbance into what we call sound. Does a falling tree make a noise? Only if you hear it – *decode* it. Everything in our reality is a frequency field of information operating within the overall ‘Wi-Fi’ field that I call The Field. A vibrational disturbance is generated in The Field by the fields of the falling tree or building. These disturbance waves are what we decode into the sound of them falling. If no one is there to do that then neither will make any noise. Reality is created by the observer – *decoder* – and the *perceptions* of the observer affect the decoding process. For this reason different people – different *perceptions* – will perceive the same reality or situation in a different way. What one may perceive as a nightmare another will see as an opportunity. The question of why the Cult is so focused on controlling human perception now answers itself. All experienced reality is the act of decoding and we don’t experience Wi-Fi until it is decoded on the computer screen. The sight and sound of an Internet video is encoded in the Wi-Fi all around us, but we don’t see or hear it until the computer decodes that information. Taste, smell and touch are all phenomena of the brain as a result of the same process. We don’t taste, smell or feel anything except in the brain and there are pain relief techniques that seek to block the signal from the site of discomfort to the brain because if the brain doesn’t decode that signal we don’t feel pain. Pain is in the brain and only appears to be at the point of impact thanks to the feedback loop between them. We don’t see anything until electrical information from the sight senses is decoded in an area at the back of the brain. If that area is damaged we can go blind when our eyes are perfectly okay. So why do we go blind if we damage an eye? We damage the information processing between the waveform visual information and the visual decoding area of the brain. If information doesn’t reach the brain in a form it can decode then we can’t see the visual reality that it represents. What’s more the brain is decoding only a fraction of the information it receives and the rest is absorbed by the

sub-conscious mind. This explanation is from the science magazine, *Wonderpedia*:

Every second, 11 million sensations crackle along these [brain] pathways ... The brain is confronted with an alarming array of images, sounds and smells which it rigorously filters down until it is left with a manageable list of around 40. Thus 40 sensations per second make up what we perceive as reality.

The 'world' is not what people are told to believe that is it and the inner circles of the Cult *know that*.

### **Illusory 'physical' reality**

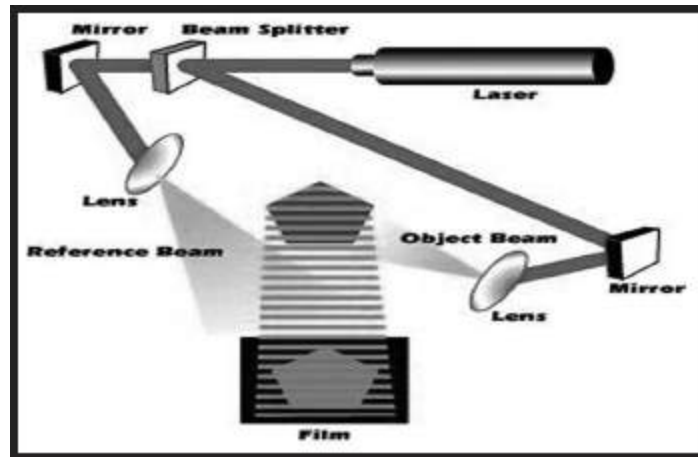
We can only see a smear of 0.005 percent of the Universe which is only one of a vast array of universes – 'mansions' – within infinite reality. Even then the brain decodes only 40 pieces of information ('sensations') from a potential *11 million* that we receive every second. Two points strike you from this immediately: The sheer breathtaking stupidity of believing we know anything so rigidly that there's nothing more to know; and the potential for these processes to be manipulated by a malevolent force to control the reality of the population. One thing I can say for sure with no risk of contradiction is that when you can perceive an almost indescribable fraction of infinite reality there is always more to know as in tidal waves of it. Ancient Greek philosopher Socrates was so right when he said that wisdom is to know how little we know. How obviously true that is when you think that we are experiencing a physical world of solidity that is neither physical nor solid and a world of apartness when everything is connected. Cult-controlled 'science' dismisses the so-called 'paranormal' and all phenomena related to that when the 'para'-normal is perfectly normal and explains the alleged 'great mysteries' which dumbfound scientific minds. There is a reason for this. A 'scientific mind' in terms of the mainstream is a material mind, a five-sense mind imprisoned in see it, touch it, hear it, smell it and taste it. Phenomena and happenings that can't be explained that way leave the 'scientific mind' bewildered and the rule is that if they



can't account for why something is happening then it can't, by definition, be happening. I beg to differ. Telepathy is thought waves passing through The Field (think wave disturbance again) to be decoded by someone able to connect with that wavelength (information). For example: You can pick up the thought waves of a friend at any distance and at the very least that will bring them to mind. A few minutes later the friend calls you. 'My god', you say, 'that's incredible – I was just thinking of you.' Ah, but *they* were thinking of *you* before they made the call and that's what you decoded. Native peoples not entrapped in five-sense reality do this so well it became known as the 'bush telegraph'. Those known as psychics and mediums (genuine ones) are doing the same only across dimensions of reality. 'Mind over matter' comes from the fact that matter and mind are the *same*. The state of one influences the state of the other. Indeed one *and* the other are illusions. They are aspects of the same field. Paranormal phenomena are all explainable so why are they still considered 'mysteries' or not happening? Once you go down this road of understanding you begin to expand awareness beyond the five senses and that's the nightmare for the Cult.



**Figure 13:** Holograms are not solid, but the best ones appear to be.



**Figure 14:** How holograms are created by capturing a waveform version of the subject image.

### **Holographic 'solidity'**

Our reality is not solid, it is holographic. We are now well aware of holograms which are widely used today. Two-dimensional information is decoded into a three-dimensional reality that is not solid although can very much appear to be (Fig 13). Holograms are created with a laser divided into two parts. One goes directly onto a holographic photographic print ('reference beam') and the other takes a waveform image of the subject ('working beam') before being directed onto the print where it 'collides' with the other half of the laser (Fig 14). This creates a *waveform* interference pattern which contains the wavefield information of whatever is being photographed (Fig 15 overleaf). The process can be likened to dropping pebbles in a pond. Waves generated by each one spread out across the water to collide with the others and create a wave representation of where the stones fell and at what speed, weight and distance. A waveform interference pattern of a hologram is akin to the waveform information in The Field which the five senses decode into electrical signals to be decoded by the brain into a holographic illusory 'physical' reality. In the same way when a laser (think human attention) is directed at the waveform interference pattern a three-dimensional version of the subject is projected into apparently 'solid' reality (Fig 16). An amazing trait of holograms reveals more 'paranormal mysteries'. Information of the *whole*

hologram is encoded in waveform in every part of the interference pattern by the way they are created. This means that every *part* of a hologram is a smaller version of the whole. Cut the interference wave-pattern into four and you won't get four parts of the image. You get quarter-sized versions of the *whole* image. The body is a hologram and the same applies. Here we have the basis of acupuncture, reflexology and other forms of healing which identify representations of the whole body in all of the parts, hands, feet, ears, everywhere. Skilled palm readers can do what they do because the information of whole body is encoded in the hand. The concept of as above, so below, comes from this.



**Figure 15:** A waveform interference pattern that holds the information that transforms into a hologram.



**Figure 16:** Holographic people including 'Elvis' holographically inserted to sing a duet with Celine Dion.

The question will be asked of why, if solidity is illusory, we can't just walk through walls and each other. The resistance is not solid against solid; it is electromagnetic field against electromagnetic field and we decode this into the *experience* of solid against solid. We should also not underestimate the power of belief to dictate reality. What you believe is impossible *will be*. Your belief impacts on your decoding processes and they won't decode what you think is impossible. What we believe we perceive and what we perceive we experience. 'Can't dos' and 'impossibles' are like a firewall in a computer system that won't put on the screen what the firewall blocks. How vital that is to understanding how human experience has been hijacked. I explain in *The Answer, Everything You Need To Know But Have Never Been Told* and other books a long list of 'mysteries' and 'paranormal' phenomena that are not mysterious and perfectly normal once you realise what reality is and how it works. 'Ghosts' can be seen to pass through 'solid' walls because the walls are not solid and the ghost is a discarnate entity operating on a frequency so different to that of the wall that it's like two radio stations sharing the same space while never interfering with each other. I have seen ghosts do this myself. The apartness of people and objects is also an illusion. Everything is connected by the Field like all sea life is connected by the sea. It's just that within the limits of our visual reality we only 'see' holographic information and not the field of information that connects everything and from which the holographic world is made manifest. If you can only see holographic 'objects' and not the field that connects them they will appear to you as unconnected to each other in the same way that we see the computer while not seeing the Wi-Fi.

### **What you don't know *can* hurt you**

Okay, we return to those 'two worlds' of human society and the Cult with its global network of interconnecting secret societies and satanic groups which manipulate through governments, corporations, media, religions, etc. The fundamental difference between them is *knowledge*. The idea has been to keep humanity

ignorant of the plan for its total enslavement underpinned by a crucial ignorance of reality – who we are and where we are – and how we interact with it. ‘Human’ should be the interaction between our expanded eternal consciousness and the five-sense body experience. We are meant to be *in* this world in terms of the five senses but not *of* this world in relation to our greater consciousness and perspective. In that state we experience the small picture of the five senses within the wider context of the big picture of awareness beyond the five senses. Put another way the five senses see the dots and expanded awareness connects them into pictures and patterns that give context to the apparently random and unconnected. Without the context of expanded awareness the five senses see only apartness and randomness with apparently no meaning. The Cult and its other-dimensional controllers seek to intervene in the frequency realm where five-sense reality is supposed to connect with expanded reality and to keep the two apart (more on this in the final chapter). When that happens five-sense mental and emotional processes are no longer influenced by expanded awareness, or the True ‘I’, and instead are driven by the isolated perceptions of the body’s decoding systems. They are in the world *and* of it. Here we have the human plight and why humanity with its potential for infinite awareness can be so easily manipulatable and descend into such extremes of stupidity.

Once the Cult isolates five-sense mind from expanded awareness it can then program the mind with perceptions and beliefs by controlling information that the mind receives through the ‘education’ system of the formative years and the media perceptual bombardment and censorship of an entire lifetime. Limit perception and a sense of the possible through limiting knowledge by limiting and skewing information while censoring and discrediting that which could set people free. As the title of another of my books says ... *And The Truth Shall Set You Free*. For this reason the last thing the Cult wants in circulation is the truth about anything – especially the reality of the eternal ‘I’ – and that’s why it is desperate to control information. The Cult knows that information becomes perception

which becomes behaviour which, collectively, becomes human society. Cult-controlled and funded mainstream 'science' denies the existence of an eternal 'I' and seeks to dismiss and trash all evidence to the contrary. Cult-controlled mainstream religion has a version of 'God' that is little more than a system of control and dictatorship that employs threats of damnation in an afterlife to control perceptions and behaviour in the here and now through fear and guilt. Neither is true and it's the 'neither' that the Cult wishes to suppress. This 'neither' is that everything is an expression, a point of attention, within an infinite state of consciousness which is the real meaning of the term 'God'.

Perceptual obsession with the 'physical body' and five-senses means that 'God' becomes personified as a bearded bloke sitting among the clouds or a raging bully who loves us if we do what 'he' wants and condemns us to the fires of hell if we don't. These are no more than a 'spiritual' fairy tales to control and dictate events and behaviour through fear of this 'God' which has bizarrely made 'God-fearing' in religious circles a state to be desired. I would suggest that fearing *anything* is not to be encouraged and celebrated, but rather deleted. You can see why 'God fearing' is so beneficial to the Cult and its religions when *they* decide what 'God' wants and what 'God' demands (the Cult demands) that everyone do. As the great American comedian Bill Hicks said satirising a Christian zealot: 'I think what God meant to say.' How much of this infinite awareness ('God') that we access is decided by how far we choose to expand our perceptions, self-identity and sense of the possible. The scale of self-identity reflects itself in the scale of awareness that we can connect with and are influenced by – how much knowing and insight we have instead of programmed perception. You cannot expand your awareness into the infinity of possibility when you believe that you are little me Peter the postman or Mary in marketing and nothing more. I'll deal with this in the concluding chapter because it's crucial to how we turnaround current events.

## **Where the Cult came from**

When I realised in the early 1990s there was a Cult network behind global events I asked the obvious question: When did it start? I took it back to ancient Rome and Egypt and on to Babylon and Sumer in Mesopotamia, the 'Land Between Two Rivers', in what we now call Iraq. The two rivers are the Tigris and Euphrates and this region is of immense historical and other importance to the Cult, as is the land called Israel only 550 miles away by air. There is much more going on with deep esoteric meaning across this whole region. It's not only about 'wars for oil'. Priceless artefacts from Mesopotamia were stolen or destroyed after the American and British invasion of Iraq in 2003 justified by the lies of Boy Bush and Tony Blair (their Cult masters) about non-existent 'weapons of mass destruction'.

Mesopotamia was the location of Sumer (about 5,400BC to 1,750BC), and Babylon (about 2,350BC to 539BC). Sabbatians may have become immensely influential in the Cult in modern times but they are part of a network that goes back into the mists of history. Sumer is said by historians to be the 'cradle of civilisation'. I disagree. I say it was the re-start of what we call human civilisation after cataclysmic events symbolised in part as the 'Great Flood' destroyed the world that existed before. These fantastic upheavals that I have been describing in detail in the books since the early 1990s appear in accounts and legends of ancient cultures across the world and they are supported by geological and biological evidence. Stone tablets found in Iraq detailing the Sumer period say the cataclysms were caused by non-human 'gods' they call the Anunnaki. These are described in terms of extraterrestrial visitations in which knowledge supplied by the Anunnaki is said to have been the source of at least one of the world's oldest writing systems and developments in astronomy, mathematics and architecture that were way ahead of their time. I have covered this subject at length in *The Biggest Secret* and *Children of the Matrix* and the same basic 'Anunnaki' story can be found in Zulu accounts in South Africa where the late and very great Zulu high shaman Credo Mutwa told me that the Sumerian Anunnaki were known by Zulus as the Chitauri or 'children of the serpent'. See my six-hour video interview with Credo on this subject entitled *The*

*Reptilian Agenda* recorded at his then home near Johannesburg in 1999 which you can watch on the Ickonic media platform.

The Cult emerged out of Sumer, Babylon and Egypt (and elsewhere) and established the Roman Empire before expanding with the Romans into northern Europe from where many empires were savagely imposed in the form of Cult-controlled societies all over the world. Mass death and destruction was their calling card. The Cult established its centre of operations in Europe and European Empires were Cult empires which allowed it to expand into a global force. Spanish and Portuguese colonialists headed for Central and South America while the British and French targeted North America. Africa was colonised by Britain, France, Belgium, the Netherlands, Portugal, Spain, Italy, and Germany. Some like Britain and France moved in on the Middle East. The British Empire was by far the biggest for a simple reason. By now Britain was the headquarters of the Cult from which it expanded to form Canada, the United States, Australia and New Zealand. The Sun never set on the British Empire such was the scale of its occupation. London remains a global centre for the Cult along with Rome and the Vatican although others have emerged in Israel and China. It is no accident that the 'virus' is alleged to have come out of China while Italy was chosen as the means to terrify the Western population into compliance with 'Covid' fascism. Nor that Israel has led the world in 'Covid' fascism and mass 'vaccination'.

You would think that I would mention the United States here, but while it has been an important means of imposing the Cult's will it is less significant than would appear and is currently in the process of having what power it does have deleted. The Cult in Europe has mostly loaded the guns for the US to fire. America has been controlled from Europe from the start through Cult operatives in Britain and Europe. The American Revolution was an illusion to make it appear that America was governing itself while very different forces were pulling the strings in the form of Cult families such as the Rothschilds through the Rockefellers and other subordinates. The Rockefellers are extremely close to Bill Gates and



established both scalpel and drug 'medicine' and the World Health Organization. They play a major role in the development and circulation of vaccines through the Rockefeller Foundation on which Bill Gates said his Foundation is based. Why wouldn't this be the case when the Rockefellers and Gates are on the same team? Cult infiltration of human society goes way back into what we call history and has been constantly expanding and centralising power with the goal of establishing a global structure to dictate everything. Look how this has been advanced in great leaps with the 'Covid' hoax.

### **The non-human dimension**

I researched and observed the comings and goings of Cult operatives through the centuries and even thousands of years as they were born, worked to promote the agenda within the secret society and satanic networks, and then died for others to replace them. Clearly there had to be a coordinating force that spanned this entire period while operatives who would not have seen the end goal in their lifetimes came and went advancing the plan over millennia. I went in search of that coordinating force with the usual support from the extraordinary synchronicity of my life which has been an almost daily experience since 1990. I saw common themes in religious texts and ancient cultures about a non-human force manipulating human society from the hidden. Christianity calls this force Satan, the Devil and demons; Islam refers to the Jinn or Djinn; Zulus have their Chitauri (spelt in other ways in different parts of Africa); and the Gnostic people in Egypt in the period around and before 400AD referred to this phenomena as the 'Archons', a word meaning rulers in Greek. Central American cultures speak of the 'Predators' among other names and the same theme is everywhere. I will use 'Archons' as a collective name for all of them. When you see how their nature and behaviour is described all these different sources are clearly talking about the same force. Gnostics described the Archons in terms of 'luminous fire' while Islam relates the Jinn to 'smokeless fire'. Some refer to beings in form that could occasionally be seen, but the most common of common theme is that they operate from

unseen realms which means almost all existence to the visual processes of humans. I had concluded that this was indeed the foundation of human control and that the Cult was operating within the human frequency band on behalf of this hidden force when I came across the writings of Gnostics which supported my conclusions in the most extraordinary way.

A sealed earthen jar was found in 1945 near the town of Nag Hammadi about 75-80 miles north of Luxor on the banks of the River Nile in Egypt. Inside was a treasure trove of manuscripts and texts left by the Gnostic people some 1,600 years earlier. They included 13 leather-bound papyrus codices (manuscripts) and more than 50 texts written in Coptic Egyptian estimated to have been hidden in the jar in the period of 400AD although the source of the information goes back much further. Gnostics oversaw the Great or Royal Library of Alexandria, the fantastic depository of ancient texts detailing advanced knowledge and accounts of human history. The Library was dismantled and destroyed in stages over a long period with the death-blow delivered by the Cult-established Roman Church in the period around 415AD. The Church of Rome was the Church of Babylon relocated as I said earlier. Gnostics were not a race. They were a way of perceiving reality. Whenever they established themselves and their information circulated the terrorists of the Church of Rome would target them for destruction. This happened with the Great Library and with the Gnostic Cathars who were burned to death by the psychopaths after a long period of oppression at the siege of the Castle of Monségur in southern France in 1244. The Church has always been terrified of Gnostic information which demolishes the official Christian narrative although there is much in the Bible that supports the Gnostic view if you read it in another way. To anyone studying the texts of what became known as the Nag Hammadi Library it is clear that great swathes of Christian and Biblical belief has its origin with Gnostics sources going back to Sumer. Gnostic themes have been twisted to manipulate the perceived reality of Bible believers. Biblical texts have been in the open for centuries where they could be changed while Gnostic

documents found at Nag Hammadi were sealed away and untouched for 1,600 years. What you see is what they wrote.

### **Use your *pneuma* not your *nous***

Gnosticism and Gnostic come from 'gnosis' which means knowledge, or rather *secret* knowledge, in the sense of spiritual awareness – knowledge about reality and life itself. The desperation of the Cult's Church of Rome to destroy the Gnostics can be understood when the knowledge they were circulating was the last thing the Cult wanted the population to know. Sixteen hundred years later the same Cult is working hard to undermine and silence me for the same reason. The dynamic between knowledge and ignorance is a constant. 'Time' appears to move on, but essential themes remain the same. We are told to 'use your nous', a Gnostic word for head/brain/intelligence. They said, however, that spiritual awakening or 'salvation' could only be secured by expanding awareness *beyond* what they called *nous* and into *pneuma* or Infinite Self. Obviously as I read these texts the parallels with what I have been saying since 1990 were fascinating to me. There is a universal truth that spans human history and in that case why wouldn't we be talking the same language 16 centuries apart? When you free yourself from the perception program of the five senses and explore expanded realms of consciousness you are going to connect with the same information no matter what the perceived 'era' within a manufactured timeline of a single and tiny range of manipulated frequency. Humans working with 'smart' technology or knocking rocks together in caves is only a timeline appearing to operate within the human frequency band. Expanded awareness and the knowledge it holds have always been there whether the era be Stone Age or computer age. We can only access that knowledge by opening ourselves to its frequency which the five-sense prison cell is designed to stop us doing. Gates, Fauci, Whitty, Vallance, Zuckerberg, Brin, Page, Wojcicki, Bezos, and all the others behind the 'Covid' hoax clearly have a long wait before their range of frequency can make that connection given that an open heart is

crucial to that as we shall see. Instead of accessing knowledge directly through expanded awareness it is given to Cult operatives by the secret society networks of the Cult where it has been passed on over thousands of years outside the public arena. Expanded realms of consciousness is where great artists, composers and writers find their inspiration and where truth awaits anyone open enough to connect with it. We need to go there fast.

## **Archon hijack**

A fifth of the Nag Hammadi texts describe the existence and manipulation of the Archons led by a 'Chief Archon' they call 'Yaldabaoth', or the 'Demiurge', and this is the Christian 'Devil', 'Satan', 'Lucifer', and his demons. Archons in Biblical symbolism are the 'fallen ones' which are also referred to as fallen angels after the angels expelled from heaven according to the Abrahamic religions of Judaism, Christianity and Islam. These angels are claimed to tempt humans to 'sin' ongoing and you will see how accurate that symbolism is during the rest of the book. The theme of 'original sin' is related to the 'Fall' when Adam and Eve were 'tempted by the serpent' and fell from a state of innocence and 'obedience' (connection) with God into a state of disobedience (disconnection). The Fall is said to have brought sin into the world and corrupted everything including human nature. Yaldabaoth, the 'Lord Archon', is described by Gnostics as a 'counterfeit spirit', 'The Blind One', 'The Blind God', and 'The Foolish One'. The Jewish name for Yaldabaoth in Talmudic writings is Samael which translates as 'Poison of God', or 'Blindness of God'. You see the parallels. Yaldabaoth in Islamic belief is the Muslim Jinn devil known as Shaytan – Shaytan is Satan as the same themes are found all over the world in every religion and culture. The 'Lord God' of the Old Testament is the 'Lord Archon' of Gnostic manuscripts and that's why he's such a bloodthirsty bastard. Satan is known by Christians as 'the Demon of Demons' and Gnostics called Yaldabaoth the 'Archon of Archons'. Both are known as 'The Deceiver'. We are talking about the same 'bloke' for sure and these common themes

using different names, storylines and symbolism tell a common tale of the human plight.

Archons are referred to in Nag Hammadi documents as mind parasites, inverters, guards, gatekeepers, detainers, judges, pitiless ones and deceivers. The 'Covid' hoax alone is a glaring example of all these things. The Biblical 'God' is so different in the Old and New Testaments because they are not describing the same phenomenon. The vindictive, angry, hate-filled, 'God' of the Old Testament, known as Yahweh, is Yaldabaoth who is depicted in Cult-dictated popular culture as the 'Dark Lord', 'Lord of Time', Lord (Darth) Vader and Dormammu, the evil ruler of the 'Dark Dimension' trying to take over the 'Earth Dimension' in the Marvel comic movie, *Dr Strange*. Yaldabaoth is both the Old Testament 'god' and the Biblical 'Satan'. Gnostics referred to Yaldabaoth as the 'Great Architect of the Universe' and the Cult-controlled Freemason network calls their god 'the 'Great Architect of the Universe' (also Grand Architect). The 'Great Architect' Yaldabaoth is symbolised by the Cult as the all-seeing eye at the top of the pyramid on the Great Seal of the United States and the dollar bill. Archon is encoded in *arch*-itect as it is in *arch*-angels and *arch*-bishops. All religions have the theme of a force for good and force for evil in some sort of spiritual war and there is a reason for that – the theme is true. The Cult and its non-human masters are quite happy for this to circulate. They present themselves as the force for good fighting evil when they are really the force of evil (absence of love). The whole foundation of Cult modus operandi is inversion. They promote themselves as a force for good and anyone challenging them in pursuit of peace, love, fairness, truth and justice is condemned as a satanic force for evil. This has been the game plan throughout history whether the Church of Rome inquisitions of non-believers or 'conspiracy theorists' and 'anti-vaxxers' of today. The technique is the same whatever the timeline era.

**Yaldabaoth is revolting (true)**

Yaldabaoth and the Archons are said to have revolted against God with Yaldabaoth claiming to *be* God – the *All That Is*. The Old Testament ‘God’ (Yaldabaoth) demanded to be worshipped as such: ‘*I am the LORD, and there is none else, there is no God beside me*’ (Isaiah 45:5). I have quoted in other books a man who said he was the unofficial son of the late Baron Philippe de Rothschild of the Mouton-Rothschild wine producing estates in France who died in 1988 and he told me about the Rothschild ‘revolt from God’. The man said he was given the name Phillip Eugene de Rothschild and we shared long correspondence many years ago while he was living under another identity. He said that he was conceived through ‘occult incest’ which (within the Cult) was ‘normal and to be admired’. ‘Phillip’ told me about his experience attending satanic rituals with rich and famous people whom he names and you can see them and the wider background to Cult Satanism in my other books starting with *The Biggest Secret*. Cult rituals are interactions with Archontic ‘gods’. ‘Phillip’ described Baron Philippe de Rothschild as ‘a master Satanist and hater of God’ and he used the same term ‘revolt from God’ associated with Yaldabaoth/Satan/Lucifer/the Devil in describing the Sabbatian Rothschild dynasty. ‘I played a key role in my family’s revolt from God’, he said. That role was to infiltrate in classic Sabbatian style the Christian Church, but eventually he escaped the mind-prison to live another life. The Cult has been targeting religion in a plan to make worship of the Archons the global one-world religion. Infiltration of Satanism into modern ‘culture’, especially among the young, through music videos, stage shows and other means, is all part of this.

Nag Hammadi texts describe Yaldabaoth and the Archons in their prime form as energy – consciousness – and say they can take form if they choose in the same way that consciousness takes form as a human. Yaldabaoth is called ‘formless’ and represents a deeply inverted, distorted and chaotic state of consciousness which seeks to attach to humans and turn them into a likeness of itself in an attempt at assimilation. For that to happen it has to manipulate

humans into low frequency mental and emotional states that match its own. Archons can certainly appear in human form and this is the origin of the psychopathic personality. The energetic distortion Gnostics called Yaldabaoth is psychopathy. When psychopathic Archons take human form that human will be a psychopath as an expression of Yaldabaoth consciousness. Cult psychopaths are Archons in human form. The principle is the same as that portrayed in the 2009 *Avatar* movie when the American military travelled to a fictional Earth-like moon called Pandora in the Alpha Centauri star system to infiltrate a society of blue people, or Na'vi, by hiding within bodies that looked like the Na'vi. Archons posing as humans have a particular hybrid information field, part human, part Archon, (the ancient 'demigods') which processes information in a way that manifests behaviour to match their psychopathic evil, lack of empathy and compassion, and stops them being influenced by the empathy, compassion and love that a fully-human information field is capable of expressing. Cult bloodlines interbreed, be they royalty or dark suits, for this reason and you have their obsession with incest. Interbreeding with full-blown humans would dilute the Archontic energy field that guarantees psychopathy in its representatives in the human realm.

Gnostic writings say the main non-human forms that Archons take are *serpentine* (what I have called for decades 'reptilian' amid unbounded ridicule from the Archontically-programmed) and what Gnostics describe as 'an unborn baby or foetus with grey skin and dark, unmoving eyes'. This is an excellent representation of the ET 'Greys' of UFO folklore which large numbers of people claim to have seen and been abducted by – Zulu shaman Credo Mutwa among them. I agree with those that believe in extraterrestrial or interdimensional visitations today and for thousands of years past. No wonder with their advanced knowledge and technological capability they were perceived and worshipped as gods for technological and other 'miracles' they appeared to perform. Imagine someone arriving in a culture disconnected from the modern world with a smartphone and computer. They would be

seen as a 'god' capable of 'miracles'. The Renegade Mind, however, wants to know the source of everything and not only the way that source manifests as human or non-human. In the same way that a Renegade Mind seeks the original source material for the 'Covid virus' to see if what is claimed is true. The original source of Archons in form is consciousness – the distorted state of consciousness known to Gnostics as Yaldabaoth.

### **'Revolt from God' is energetic disconnection**

Where I am going next will make a lot of sense of religious texts and ancient legends relating to 'Satan', Lucifer' and the 'gods'. Gnostic descriptions sync perfectly with the themes of my own research over the years in how they describe a consciousness distortion seeking to impose itself on human consciousness. I've referred to the core of infinite awareness in previous books as Infinite Awareness in Awareness of Itself. By that I mean a level of awareness that knows that it is all awareness and is aware of all awareness. From here comes the frequency of love in its true sense and balance which is what love is on one level – the balance of all forces into a single whole called Oneness and Isness. The more we disconnect from this state of love that many call 'God' the constituent parts of that Oneness start to unravel and express themselves as a part and not a whole. They become individualised as intellect, mind, selfishness, hatred, envy, desire for power over others, and such like. This is not a problem in the greater scheme in that 'God', the *All That Is*, can experience all these possibilities through different expressions of itself including humans. What we as expressions of the whole experience the *All That Is* experiences. We are the *All That Is* experiencing itself. As we withdraw from that state of Oneness we disconnect from its influence and things can get very unpleasant and very stupid. Archontic consciousness is at the extreme end of that. It has so disconnected from the influence of Oneness that it has become an inversion of unity and love, an inversion of everything, an inversion of life itself. Evil is appropriately live written backwards. Archontic consciousness is obsessed with death, an inversion of life,



and so its manifestations in Satanism are obsessed with death. They use inverted symbols in their rituals such as the inverted pentagram and cross. Sabbatians as Archontic consciousness incarnate invert Judaism and every other religion and culture they infiltrate. They seek disunity and chaos and they fear unity and harmony as they fear love like garlic to a vampire. As a result the Cult, Archons incarnate, act with such evil, psychopathy and lack of empathy and compassion disconnected as they are from the source of love. How could Bill Gates and the rest of the Archontic psychopaths do what they have to human society in the 'Covid' era with all the death, suffering and destruction involved and have no emotional consequence for the impact on others? Now you know. Why have Zuckerberg, Brin, Page, Wojcicki and company callously censored information warning about the dangers of the 'vaccine' while thousands have been dying and having severe, sometimes life-changing reactions? Now you know. Why have Tedros, Fauci, Whitty, Vallance and their like around the world been using case and death figures they're aware are fraudulent to justify lockdowns and all the deaths and destroyed lives that have come from that? Now you know. Why did Christian Drosten produce and promote a 'testing' protocol that he knew couldn't test for infectious disease which led to a global human catastrophe. Now you know. The Archontic mind doesn't give a shit ([Fig 17](#)). I personally think that Gates and major Cult insiders are a form of AI cyborg that the Archons want humans to become.

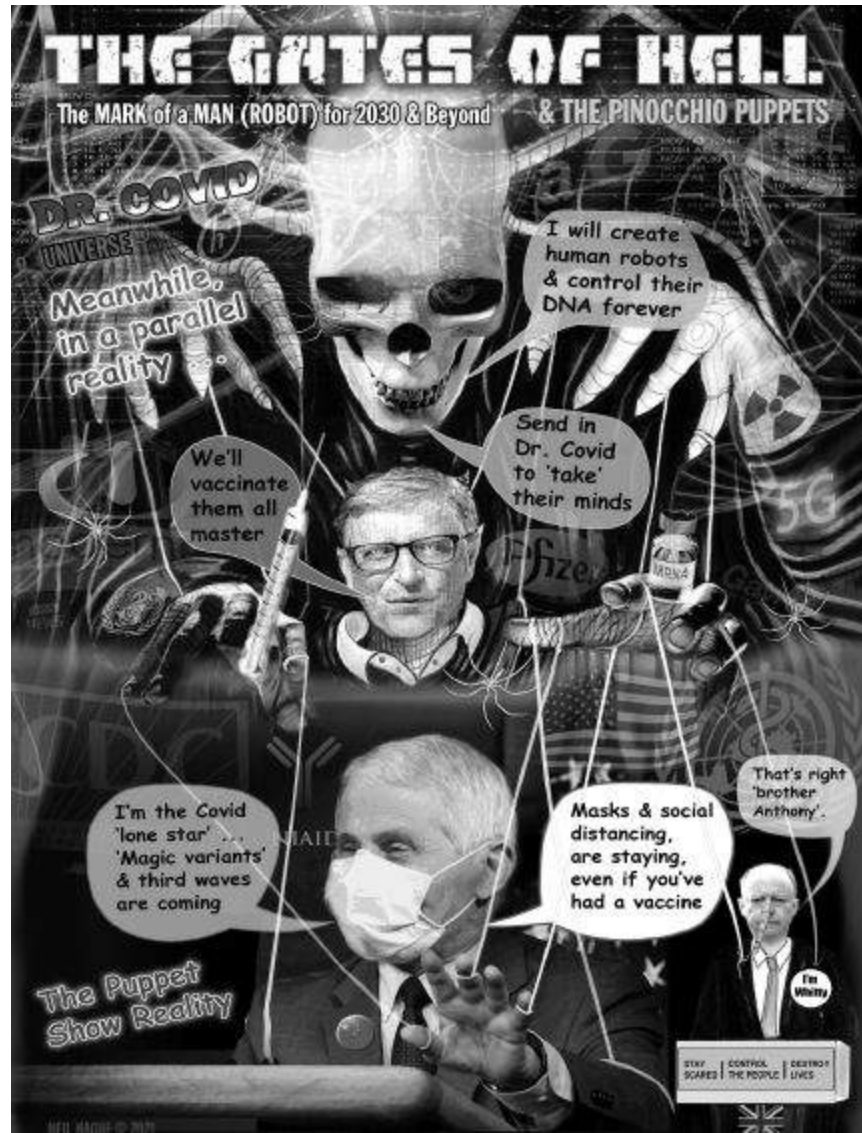


Figure 17: Artist Neil Hague's version of the 'Covid' hierarchy.

## Human batteries

A state of such inversion does have its consequences, however. The level of disconnection from the Source of All means that you withdraw from that source of energetic sustenance and creativity. This means that you have to find your own supply of energetic power and it has – us. When the Morpheus character in the first *Matrix* movie held up a battery he spoke a profound truth when he said: 'The Matrix is a computer-generated dream world built to keep us under control in order to change the human being into one of

these.’ The statement was true in all respects. We do live in a technologically-generated virtual reality simulation (more very shortly) and we have been manipulated to be an energy source for Archontic consciousness. The Disney-Pixar animated movie *Monsters, Inc.* in 2001 symbolised the dynamic when monsters in their world had no energy source and they would enter the human world to terrify children in their beds, catch the child’s scream, terror (low-vibrational frequencies), and take that energy back to power the monster world. The lead character you might remember was a single giant eye and the symbolism of the Cult’s all-seeing eye was obvious. Every thought and emotion is broadcast as a frequency unique to that thought and emotion. Feelings of love and joy, empathy and compassion, are high, quick, frequencies while fear, depression, anxiety, suffering and hate are low, slow, dense frequencies. Which kind do you think Archontic consciousness can connect with and absorb? In such a low and dense frequency state there’s no way it can connect with the energy of love and joy. Archons can only feed off energy compatible with their own frequency and they and their Cult agents want to delete the human world of love and joy and manipulate the transmission of low vibrational frequencies through low-vibrational human mental and emotional states. *We are their energy source.* Wars are energetic banquets to the Archons – a world war even more so – and think how much low-frequency mental and emotional energy has been generated from the consequences for humanity of the ‘Covid’ hoax orchestrated by Archons incarnate like Gates.

The ancient practice of human sacrifice ‘to the gods’, continued in secret today by the Cult, is based on the same principle. ‘The gods’ are Archontic consciousness in different forms and the sacrifice is induced into a state of intense terror to generate the energy the Archontic frequency can absorb. Incarnate Archons in the ritual drink the blood which contains an adrenaline they crave which floods into the bloodstream when people are terrorised. Most of the sacrifices, ancient and modern, are children and the theme of ‘sacrificing young virgins to the gods’ is just code for children. They

have a particular pre-puberty energy that Archons want more than anything and the energy of the young in general is their target. The California Department of Education wants students to chant the names of Aztec gods (Archontic gods) once worshipped in human sacrifice rituals in a curriculum designed to encourage them to 'challenge racist, bigoted, discriminatory, imperialist/colonial beliefs', join 'social movements that struggle for social justice', and 'build new possibilities for a post-racist, post-systemic racism society'. It's the usual Woke crap that inverts racism and calls it anti-racism. In this case solidarity with 'indigenous tribes' is being used as an excuse to chant the names of 'gods' to which people were sacrificed (and still are in secret). What an example of Woke's inability to see beyond black and white, us and them, They condemn the colonisation of these tribal cultures by Europeans (quite right), but those cultures sacrificing people including children to their 'gods', and mass murdering untold numbers as the Aztecs did, is just fine. One chant is to the Aztec god Tezcatlipoca who had a man sacrificed to him in the 5th month of the Aztec calendar. His heart was cut out and he was eaten. Oh, that's okay then. Come on children ... after three ... Other sacrificial 'gods' for the young to chant their allegiance include Quetzalcoatl, Huitzilopochtli and Xipe Totec. The curriculum says that 'chants, affirmations, and energizers can be used to bring the class together, build unity around ethnic studies principles and values, and to reinvigorate the class following a lesson that may be emotionally taxing or even when student engagement may appear to be low'. Well, that's the cover story, anyway. Chanting and mantras are the repetition of a particular frequency generated from the vocal cords and chanting the names of these Archontic 'gods' tunes you into their frequency. That is the last thing you want when it allows for energetic synchronisation, attachment and perceptual influence. Initiates chant the names of their 'Gods' in their rituals for this very reason.

## **Vampires of the Woke**

Paedophilia is another way that Archons absorb the energy of children. Paedophiles possessed by Archontic consciousness are used as the conduit during sexual abuse for discarnate Archons to vampire the energy of the young they desire so much. Stupendous numbers of children disappear every year never to be seen again although you would never know from the media. Imagine how much low-vibrational energy has been generated by children during the 'Covid' hoax when so many have become depressed and psychologically destroyed to the point of killing themselves. Shocking numbers of children are now taken by the state from loving parents to be handed to others. I can tell you from long experience of researching this since 1996 that many end up with paedophiles and assets of the Cult through corrupt and Cult-owned social services which in the reframing era has hired many psychopaths and emotionless automatons to do the job. Children are even stolen to order using spurious reasons to take them by the corrupt and secret (because they're corrupt) 'family courts'. I have written in detail in other books, starting with *The Biggest Secret* in 1997, about the ubiquitous connections between the political, corporate, government, intelligence and military elites (Cult operatives) and Satanism and paedophilia. If you go deep enough both networks have an interlocking leadership. The Woke mentality has been developed by the Cult for many reasons: To promote almost every aspect of its agenda; to hijack the traditional political left and turn it fascist; to divide and rule; and to target agenda pushbackers. But there are other reasons which relate to what I am describing here. How many happy and joyful Wokers do you ever see especially at the extreme end? They are a mental and psychological mess consumed by emotional stress and constantly emotionally cocked for the next explosion of indignation at someone referring to a female as a female. They are walking, talking, batteries as Morpheus might say emitting frequencies which both enslave them in low-vibrational bubbles of perceptual limitation and feed the Archons. Add to this the hatred claimed to be love; fascism claimed to 'anti-fascism', racism claimed to be 'anti-racism';

exclusion claimed to inclusion; and the abuse-filled Internet trolling. You have a purpose-built Archontic energy system with not a wind turbine in sight and all founded on Archontic *inversion*. We have whole generations now manipulated to serve the Archons with their actions and energy. They will be doing so their entire adult lives unless they snap out of their Archon-induced trance. Is it really a surprise that Cult billionaires and corporations put so much money their way? Where is the energy of joy and laughter, including laughing at yourself which is confirmation of your own emotional security? Mark Twain said: 'The human race has one really effective weapon, and that is laughter.' We must use it all the time. Woke has destroyed comedy because it has no humour, no joy, sense of irony, or self-deprecation. Its energy is dense and intense. *Mmmmm*, lunch says the Archontic frequency. Rudolf Steiner (1861-1925) was the Austrian philosopher and famous esoteric thinker who established Waldorf education or Steiner schools to treat children like unique expressions of consciousness and not minds to be programmed with the perceptions determined by authority. I'd been writing about this energy vampiring for decades when I was sent in 2016 a quote by Steiner. He was spot on:

There are beings in the spiritual realms for whom anxiety and fear emanating from human beings offer welcome food. When humans have no anxiety and fear, then these creatures starve. If fear and anxiety radiates from people and they break out in panic, then these creatures find welcome nutrition and they become more and more powerful. These beings are hostile towards humanity. Everything that feeds on negative feelings, on anxiety, fear and superstition, despair or doubt, are in reality hostile forces in super-sensible worlds, launching cruel attacks on human beings, while they are being fed ... These are exactly the feelings that belong to contemporary culture and materialism; because it estranges people from the spiritual world, it is especially suited to evoke hopelessness and fear of the unknown in people, thereby calling up the above mentioned hostile forces against them.

Pause for a moment from this perspective and reflect on what has happened in the world since the start of 2020. Not only will pennies drop, but billion dollar bills. We see the same theme from Don Juan Matus, a Yaqui Indian shaman in Mexico and the information source for Peruvian-born writer, Carlos Castaneda, who wrote a series of

books from the 1960s to 1990s. Don Juan described the force manipulating human society and his name for the Archons was the predator:

We have a predator that came from the depths of the cosmos and took over the rule of our lives. Human beings are its prisoners. The predator is our lord and master. It has rendered us docile, helpless. If we want to protest, it suppresses our protest. If we want to act independently, it demands that we don't do so ... indeed we are held prisoner!

They took us over because we are food to them, and they squeeze us mercilessly because we are their sustenance. Just as we rear chickens in coops, the predators rear us in human coops, humaneros. Therefore, their food is always available to them.

Different cultures, different eras, same recurring theme.

## **The 'ennoia' dilemma**

Nag Hammadi Gnostic manuscripts say that Archon consciousness has no 'ennoia'. This is directly translated as 'intentionality', but I'll use the term 'creative imagination'. The *All That Is* in awareness of itself is the source of all creativity – all possibility – and the more disconnected you are from that source the more you are subsequently denied 'creative imagination'. Given that Archon consciousness is almost entirely disconnected it severely lacks creativity and has to rely on far more mechanical processes of thought and exploit the creative potential of those that do have 'ennoia'. You can see cases of this throughout human society. Archon consciousness almost entirely dominates the global banking system and if we study how that system works you will appreciate what I mean. Banks manifest 'money' out of nothing by issuing lines of 'credit' which is 'money' that has never, does not, and will never exist except in theory. It's a confidence trick. If you think 'credit' figures-on-a-screen 'money' is worth anything you accept it as payment. If you don't then the whole system collapses through lack of confidence in the value of that 'money'. Archontic bankers with no 'ennoia' are 'lending' 'money' that doesn't exist to humans that *do* have creativity – those that have the inspired ideas and create businesses and products. Archon banking feeds off human creativity

which it controls through 'money' creation and debt. Humans have the creativity and Archons exploit that for their own benefit and control while having none themselves. Archon Internet platforms like Facebook claim joint copyright of everything that creative users post and while Archontic minds like Zuckerberg may officially head that company it will be human creatives on the staff that provide the creative inspiration. When you have limitless 'money' you can then buy other companies established by creative humans. Witness the acquisition record of Facebook, Google and their like. Survey the Archon-controlled music industry and you see non-creative dark suit executives making their fortune from the human creativity of their artists. The cases are endless. Research the history of people like Gates and Zuckerberg and how their empires were built on exploiting the creativity of others. Archon minds cannot create out of nothing, but they are skilled (because they have to be) in what Gnostic texts call 'countermimicry'. They can imitate, but not innovate. Sabbatians trawl the creativity of others through backdoors they install in computer systems through their cybersecurity systems. Archon-controlled China is globally infamous for stealing intellectual property and I remember how Hong Kong, now part of China, became notorious for making counterfeit copies of the creativity of others – 'countermimicry'. With the now pervasive and all-seeing surveillance systems able to infiltrate any computer you can appreciate the potential for Archons to vampire the creativity of humans. Author John Lamb Lash wrote in his book about the Nag Hammadi texts, *Not In His Image*:

Although they cannot originate anything, because they lack the divine factor of ennoia (intentionality), Archons can imitate with a vengeance. Their expertise is simulation (HAL, virtual reality). The Demiurge [Yaldabaoth] fashions a heaven world copied from the fractal patterns [of the original] ... His construction is celestial kitsch, like the fake Italianate villa of a Mafia don complete with militant angels to guard every portal.

This brings us to something that I have been speaking about since the turn of the millennium. Our reality is a simulation; a virtual reality that we think is real. No, I'm not kidding.



## **Human reality? Well, virtually**

I had pondered for years about whether our reality is 'real' or some kind of construct. I remembered being immensely affected on a visit as a small child in the late 1950s to the then newly-opened Planetarium on the Marylebone Road in London which is now closed and part of the adjacent Madame Tussauds wax museum. It was in the middle of the day, but when the lights went out there was the night sky projected in the Planetarium's domed ceiling and it appeared to be so real. The experience never left me and I didn't know why until around the turn of the millennium when I became certain that our 'night sky' and entire reality is a projection, a virtual reality, akin to the illusory world portrayed in the *Matrix* movies. I looked at the sky one day in this period and it appeared to me like the domed roof of the Planetarium. The release of the first *Matrix* movie in 1999 also provided a synchronistic and perfect visual representation of where my mind had been going for a long time. I hadn't come across the Gnostic Nag Hammadi texts then. When I did years later the correlation was once again astounding. As I read Gnostic accounts from 1,600 years and more earlier it was clear that they were describing the same simulation phenomenon. They tell how the Yaldabaoth 'Demiurge' and Archons created a 'bad copy' of original reality to rule over all that were captured by its illusions and the body was a prison to trap consciousness in the 'bad copy' fake reality. Read how Gnostics describe the 'bad copy' and update that to current times and they are referring to what we would call today a virtual reality simulation.

Author John Lamb Lash said 'the Demiurge fashions a heaven world copied from the fractal patterns' of the original through expertise in 'HAL' or virtual reality simulation. Fractal patterns are part of the energetic information construct of our reality, a sort of blueprint. If these patterns were copied in computer terms it would indeed give you a copy of a 'natural' reality in a non-natural frequency and digital form. The principle is the same as making a copy of a website. The original website still exists, but now you can change the copy version to make it whatever you like and it can

become very different to the original website. Archons have done this with our reality, a *synthetic* copy of prime reality that still exists beyond the frequency walls of the simulation. Trapped within the illusions of this synthetic Matrix, however, were and are human consciousness and other expressions of prime reality and this is why the Archons via the Cult are seeking to make the human body synthetic and give us synthetic AI minds to complete the job of turning the entire reality synthetic including what we perceive to be the natural world. To quote Kurzweil: 'Nanobots will infuse all the matter around us with information. Rocks, trees, everything will become these intelligent creatures.' Yes, *synthetic* 'creatures' just as 'Covid' and other genetically-manipulating 'vaccines' are designed to make the human body synthetic. From this perspective it is obvious why Archons and their Cult are so desperate to infuse synthetic material into every human with their 'Covid' scam.

### **Let there be (electromagnetic) light**

Yaldabaoth, the force that created the simulation, or Matrix, makes sense of the Gnostic reference to 'The Great Architect' and its use by Cult Freemasonry as the name of its deity. The designer of the Matrix in the movies is called 'The Architect' and that trilogy is jam-packed with symbolism relating to these subjects. I have contended for years that the angry Old Testament God (Yaldabaoth) is the 'God' being symbolically 'quoted' in the opening of Genesis as 'creating the world'. This is not the creation of prime reality – it's the creation of the *simulation*. The Genesis 'God' says: 'Let there be Light: and there was light.' But what is this 'Light'? I have said for decades that the speed of light (186,000 miles per second) is not the fastest speed possible as claimed by mainstream science and is in fact the frequency walls or outer limits of the Matrix. You can't have a fastest or slowest anything within all possibility when everything is possible. The human body is encoded to operate within the speed of light or *within the simulation* and thus we see only the tiny frequency band of visible *light*. Near-death experiencers who perceive reality outside the body during temporary 'death' describe a very different

form of light and this is supported by the Nag Hammadi texts. Prime reality beyond the simulation ('Upper Aeons' to the Gnostics) is described as a realm of incredible beauty, bliss, love and harmony – a realm of 'watery light' that is so powerful 'there are no shadows'. Our false reality of Archon control, which Gnostics call the 'Lower Aeons', is depicted as a realm with a different kind of 'light' and described in terms of chaos, 'Hell', 'the Abyss' and 'Outer Darkness', where trapped souls are tormented and manipulated by demons (relate that to the 'Covid' hoax alone). The watery light theme can be found in near-death accounts and it is not the same as *simulation* 'light' which is electromagnetic or radiation light within the speed of light – the 'Lower Aeons'. Simulation 'light' is the 'luminous fire' associated by Gnostics with the Archons. The Bible refers to Yaldabaoth as 'that old serpent, called the Devil, and Satan, which deceiveth the whole world' (Revelation 12:9). I think that making a simulated copy of prime reality ('countermimicry') and changing it dramatically while all the time manipulating humanity to believe it to be real could probably meet the criteria of deceiving the whole world. Then we come to the Cult god Lucifer – the *Light Bringer*. Lucifer is symbolic of Yaldabaoth, the bringer of radiation light that forms the bad copy simulation within the speed of light. 'He' is symbolised by the lighted torch held by the Statue of Liberty and in the name 'Illuminati'. Sabbatian-Frankism declares that Lucifer is the true god and Lucifer is the real god of Freemasonry honoured as their 'Great or Grand Architect of the Universe' (simulation).

I would emphasise, too, the way Archontic technologically-generated luminous fire of radiation has deluged our environment since I was a kid in the 1950s and changed the nature of The Field with which we constantly interact. Through that interaction technological radiation is changing us. The Smart Grid is designed to operate with immense levels of communication power with 5G expanding across the world and 6G, 7G, in the process of development. Radiation is the simulation and the Archontic manipulation system. Why wouldn't the Archon Cult wish to unleash radiation upon us to an ever-greater extreme to form

Kurzweil's 'cloud'? The plan for a synthetic human is related to the need to cope with levels of radiation beyond even anything we've seen so far. Biological humans would not survive the scale of radiation they have in their script. The Smart Grid is a technological sub-reality within the technological simulation to further disconnect five-sense perception from expanded consciousness. It's a technological prison of the mind.

### **Infusing the 'spirit of darkness'**

A recurring theme in religion and native cultures is the manipulation of human genetics by a non-human force and most famously recorded as the biblical 'sons of god' (the gods plural in the original) who interbred with the daughters of men. The Nag Hammadi *Apocryphon of John* tells the same story this way:

He [Yaldabaoth] sent his angels [Archons/demons] to the daughters of men, that they might take some of them for themselves and raise offspring for their enjoyment. And at first they did not succeed. When they had no success, they gathered together again and they made a plan together ... And the angels changed themselves in their likeness into the likeness of their mates, filling them with the spirit of darkness, which they had mixed for them, and with evil ... And they took women and begot children out of the darkness according to the likeness of their spirit.

Possession when a discarnate entity takes over a human body is an age-old theme and continues today. It's very real and I've seen it. Satanic and secret society rituals can create an energetic environment in which entities can attach to initiates and I've heard many stories of how people have changed their personality after being initiated even into lower levels of the Freemasons. I have been inside three Freemasonic temples, one at a public open day and two by just walking in when there was no one around to stop me. They were in Ryde, the town where I live, Birmingham, England, when I was with a group, and Boston, Massachusetts. They all felt the same energetically – dark, dense, low-vibrational and sinister. Demonic attachment can happen while the initiate has no idea what is going on. To them it's just a ritual to get in the Masons and do a bit of good

business. In the far more extreme rituals of Satanism human possession is even more powerful and they are designed to make possession possible. The hierarchy of the Cult is dictated by the power and perceived status of the possessing Archon. In this way the Archon hierarchy becomes the Cult hierarchy. Once the entity has attached it can influence perception and behaviour and if it attaches to the extreme then so much of its energy (information) infuses into the body information field that the hologram starts to reflect the nature of the possessing entity. This is the *Exorcist* movie type of possession when facial features change and it's known as shapeshifting. Islam's Jinn are said to be invisible tricksters who change shape, 'whisper', confuse and take human form. These are all traits of the Archons and other versions of the same phenomenon. Extreme possession could certainly infuse the 'spirit of darkness' into a partner during sex as the Nag Hammadi texts appear to describe. Such an infusion can change genetics which is also energetic information. Human genetics is information and the 'spirit of darkness' is information. Mix one with the other and change must happen. Islam has the concept of a 'Jinn baby' through possession of the mother and by Jinn taking human form. There are many ways that human genetics can be changed and remember that Archons have been aware all along of advanced techniques to do this. What is being done in human society today – and far more – was known about by Archons at the time of the 'fallen ones' and their other versions described in religions and cultures.

Archons and their human-world Cult are obsessed with genetics as we see today and they know this dictates how information is processed into perceived reality during a human life. They needed to produce a human form that would decode the simulation and this is symbolically known as 'Adam and Eve' who left the 'garden' (prime reality) and 'fell' into Matrix reality. The simulation is not a 'physical' construct (there is no 'physical'); it is a source of information. Think Wi-Fi again. The simulation is an energetic field encoded with information and body-brain systems are designed to decode that information encoded in wave or frequency form which

is transmitted to the brain as electrical signals. These are decoded by the brain to construct our sense of reality – an illusory ‘physical’ world that only exists in the brain or the mind. Virtual reality games mimic this process using the same sensory decoding system. Information is fed to the senses to decode a virtual reality that can appear so real, but isn’t (Figs 18 and 19). Some scientists believe – and I agree with them – that what we perceive as ‘physical’ reality only exists when we are looking or observing. The act of perception or focus triggers the decoding systems which turn waveform information into holographic reality. When we are not observing something our reality reverts from a holographic state to a waveform state. This relates to the same principle as a falling tree not making a noise unless someone is there to hear it or decode it. The concept makes sense from the simulation perspective. A computer is not decoding all the information in a Wi-Fi field all the time and only decodes or brings into reality on the screen that part of Wi-Fi that it’s decoding – focusing upon – at that moment.



**Figure 18:** Virtual reality technology ‘hacks’ into the body’s five-sense decoding system.



**Figure 19:** The result can be experienced as very ‘real’.

Interestingly, Professor Donald Hoffman at the Department of Cognitive Sciences at the University of California, Irvine, says that our experienced reality is like a computer interface that shows us only the level with which we interact while hiding all that exists beyond it: 'Evolution shaped us with a user interface that hides the truth. Nothing that we see is the truth – the very language of space and time and objects is the wrong language to describe reality.' He is correct in what he says on so many levels. Space and time are not a universal reality. They are a phenomenon of decoded *simulation* reality as part of the process of enslaving our sense of reality. Near-death experiencers report again and again how space and time did not exist as we perceive them once they were free of the body – body decoding systems. You can appreciate from this why Archons and their Cult are so desperate to entrap human attention in the five senses where we are in the Matrix and of the Matrix. Opening your mind to expanded states of awareness takes you beyond the information confines of the simulation and you become aware of knowledge and insights denied to you before. This is what we call 'awakening' – *awakening from the Matrix* – and in the final chapter I will relate this to current events.

## **Where are the 'aliens'?**

A simulation would explain the so-called 'Fermi Paradox' named after Italian physicist Enrico Fermi (1901-1954) who created the first nuclear reactor. He considered the question of why there is such a lack of extraterrestrial activity when there are so many stars and planets in an apparently vast universe; but what if the night sky that we see, or think we do, is a simulated projection as I say? If you control the simulation and your aim is to hold humanity fast in essential ignorance would you want other forms of life including advanced life coming and going sharing information with humanity? Or would you want them to believe they were isolated and apparently alone? Themes of human isolation and apartness are common whether they be the perception of a lifeless universe or the fascist isolation laws of the 'Covid' era. Paradoxically the very

existence of a simulation means that we are not alone when some force had to construct it. My view is that experiences that people have reported all over the world for centuries with Reptilians and Grey entities are Archon phenomena as Nag Hammadi texts describe; and that benevolent 'alien' interactions are non-human groups that come in and out of the simulation by overcoming Archon attempts to keep them out. It should be highlighted, too, that Reptilians and Greys are obsessed with *genetics* and *technology* as related by cultural accounts and those who say they have been abducted by them. Technology is their way of overcoming some of the limitations in their creative potential and our technology-driven and controlled human society of today is *archetypical* Archon-Reptilian-Grey modus operandi. Technocracy is really *Archontocracy*. The Universe does not have to be as big as it appears with a simulation. There is no space or distance only information decoded into holographic reality. What we call 'space' is only the absence of holographic 'objects' and that 'space' is The Field of energetic information which connects everything into a single whole. The same applies with the artificially-generated information field of the simulation. The Universe is not big or small as a physical reality. It is decoded information, that's all, and its perceived size is decided by the way the simulation is encoded to make it appear. The entire night sky as we perceive it only exists in our brain and so where are those 'millions of light years'? The 'stars' on the ceiling of the Planetarium looked a vast distance away.

There's another point to mention about 'aliens'. I have been highlighting since the 1990s the plan to stage a fake 'alien invasion' to justify the centralisation of global power and a world military. Nazi scientist Werner von Braun, who was taken to America by Operation Paperclip after World War Two to help found NASA, told his American assistant Dr Carol Rosin about the Cult agenda when he knew he was dying in 1977. Rosin said that he told her about a sequence that would lead to total human control by a one-world government. This included threats from terrorism, rogue nations, meteors and asteroids before finally an 'alien invasion'. All of these



things, von Braun said, would be bogus and what I would refer to as a No-Problem-Reaction-Solution. Keep this in mind when 'the aliens are coming' is the new mantra. The aliens are not coming – they are *already here* and they have infiltrated human society while looking human. French-Canadian investigative journalist Serge Monast said in 1994 that he had uncovered a NASA/military operation called Project Blue Beam which fits with what Werner von Braun predicted. Monast died of a 'heart attack' in 1996 the day after he was arrested and spent a night in prison. He was 51. He said Blue Beam was a plan to stage an alien invasion that would include religious figures beamed holographically into the sky as part of a global manipulation to usher in a 'new age' of worshipping what I would say is the Cult 'god' Yaldabaoth in a one-world religion. Fake holographic asteroids are also said to be part of the plan which again syncs with von Braun. How could you stage an illusory threat from asteroids unless they were holographic inserts? This is pretty straightforward given the advanced technology outside the public arena and the fact that our 'physical' reality is holographic anyway. Information fields would be projected and we would decode them into the illusion of a 'physical' asteroid. If they can sell a global 'pandemic' with a 'virus' that doesn't exist what will humans not believe if government and media tell them?

All this is particularly relevant as I write with the Pentagon planning to release in June, 2021, information about 'UFO sightings'. I have been following the UFO story since the early 1990s and the common theme throughout has been government and military denials and cover up. More recently, however, the Pentagon has suddenly become more talkative and apparently open with Air Force pilot radar images released of unexplained craft moving and changing direction at speeds well beyond anything believed possible with human technology. Then, in March, 2021, former Director of National Intelligence John Ratcliffe said a Pentagon report months later in June would reveal a great deal of information about UFO sightings unknown to the public. He said the report would have 'massive implications'. The order to do this was included bizarrely

in a \$2.3 trillion 'coronavirus' relief and government funding bill passed by the Trump administration at the end of 2020. I would add some serious notes of caution here. I have been pointing out since the 1990s that the US military and intelligence networks have long had craft – 'flying saucers' or anti-gravity craft – which any observer would take to be extraterrestrial in origin. Keeping this knowledge from the public allows craft flown by *humans* to be perceived as alien visitations. I am not saying that 'aliens' do not exist. I would be the last one to say that, but we have to be streetwise here. President Ronald Reagan told the UN General Assembly in 1987: 'I occasionally think how quickly our differences worldwide would vanish if we were facing an alien threat from outside this world.' That's the idea. Unite against a common 'enemy' with a common purpose behind your 'saviour force' (the Cult) as this age-old technique of mass manipulation goes global.

### **Science moves this way ...**

I could find only one other person who was discussing the simulation hypothesis publicly when I concluded it was real. This was Nick Bostrom, a Swedish-born philosopher at the University of Oxford, who has explored for many years the possibility that human reality is a computer simulation although his version and mine are not the same. Today the simulation and holographic reality hypothesis have increasingly entered the scientific mainstream. Well, the more open-minded mainstream, that is. Here are a few of the ever-gathering examples. American nuclear physicist Silas Beane led a team of physicists at the University of Bonn in Germany pursuing the question of whether we live in a simulation. They concluded that we probably do and it was likely based on a lattice of cubes. They found that cosmic rays align with that specific pattern. The team highlighted the Greisen–Zatsepin–Kuzmin (GZK) limit which refers to cosmic ray particle interaction with cosmic background radiation that creates an apparent boundary for cosmic ray particles. They say in a paper entitled 'Constraints on the Universe as a Numerical Simulation' that this 'pattern of constraint' is exactly what you

would find with a computer simulation. They also made the point that a simulation would create its own 'laws of physics' that would limit possibility. I've been making the same point for decades that the *perceived* laws of physics relate only to this reality, or what I would later call the simulation. When designers write codes to create computer and virtual reality games they are the equivalent of the laws of physics for that game. Players interact within the limitations laid out by the coding. In the same way those who wrote the codes for the simulation decided the laws of physics that would apply. These can be overridden by expanded states of consciousness, but not by those enslaved in only five-sense awareness where simulation codes rule. Overriding the codes is what people call 'miracles'. They are not. They are bypassing the encoded limits of the simulation. A population caught in simulation perception would have no idea that this was their plight. As the Bonn paper said: 'Like a prisoner in a pitch-black cell we would not be able to see the "walls" of our prison,' That's true if people remain mesmerised by the five senses. Open to expanded awareness and those walls become very clear. The main one is the speed of light.

American theoretical physicist James Gates is another who has explored the simulation question and found considerable evidence to support the idea. Gates was Professor of Physics at the University of Maryland, Director of The Center for String and Particle Theory, and on Barack Obama's Council of Advisors on Science and Technology. He and his team found *computer codes* of digital data embedded in the fabric of our reality. They relate to on-off electrical charges of 1 and 0 in the binary system used by computers. 'We have no idea what they are doing there', Gates said. They found within the energetic fabric mathematical sequences known as error-correcting codes or block codes that 'reboot' data to its original state or 'default settings' when something knocks it out of sync. Gates was asked if he had found a set of equations embedded in our reality indistinguishable from those that drive search engines and browsers and he said: 'That is correct.' Rich Terrile, director of the Centre for Evolutionary Computation and Automated Design at NASA's Jet

Propulsion Laboratory, has said publicly that he believes the Universe is a digital hologram that must have been created by a form of intelligence. I agree with that in every way. Waveform information is delivered electrically by the senses to the brain which constructs a *digital* holographic reality that we call the 'world'. This digital level of reality can be read by the esoteric art of numerology. Digital holograms are at the cutting edge of holographics today. We have digital technology everywhere designed to access and manipulate our digital level of perceived reality. Synthetic mRNA in 'Covid vaccines' has a digital component to manipulate the body's digital 'operating system'.

## **Reality is numbers**

How many know that our reality can be broken down to numbers and codes that are the same as computer games? Max Tegmark, a physicist at the Massachusetts Institute of Technology (MIT), is the author of *Our Mathematical Universe* in which he lays out how reality can be entirely described by numbers and maths in the way that a video game is encoded with the 'physics' of computer games. Our world and computer virtual reality are essentially the same.

Tegmark imagines the perceptions of characters in an advanced computer game when the graphics are so good they don't know they are in a game. They think they can bump into real objects (electromagnetic resistance in our reality), fall in love and feel emotions like excitement. When they began to study the apparently 'physical world' of the video game they would realise that everything was made of pixels (which have been found in our energetic reality as must be the case when on one level our world is digital). What computer game characters thought was physical 'stuff', Tegmark said, could actually be broken down into numbers:

And we're exactly in this situation in our world. We look around and it doesn't seem that mathematical at all, but everything we see is made out of elementary particles like quarks and electrons. And what properties does an electron have? Does it have a smell or a colour or a texture? No! ... We physicists have come up with geeky names for [Electron] properties, like

electric charge, or spin, or lepton number, but the electron doesn't care what we call it, the properties are just numbers.

This is the illusory reality Gnostics were describing. This is the simulation. The A, C, G, and T codes of DNA have a binary value – A and C = 0 while G and T = 1. This has to be when the simulation is digital and the body must be digital to interact with it. Recurring mathematical sequences are encoded throughout reality and the body. They include the Fibonacci sequence in which the two previous numbers are added to get the next one, as in ... 1, 1, 2, 3, 5, 8, 13, 21, 34, 55, etc. The sequence is encoded in the human face and body, proportions of animals, DNA, seed heads, pine cones, trees, shells, spiral galaxies, hurricanes and the number of petals in a flower. The list goes on and on. There are fractal patterns – a 'never-ending pattern that is infinitely complex and self-similar across all scales in the as above, so below, principle of holograms. These and other famous recurring geometrical and mathematical sequences such as Phi, Pi, Golden Mean, Golden Ratio and Golden Section are *computer codes* of the simulation. I had to laugh and give my head a shake the day I finished this book and it went into the production stage. I was sent an article in *Scientific American* published in April, 2021, with the headline 'Confirmed! We Live in a Simulation'. Two decades after I first said our reality is a simulation and the speed of light is its outer limit the article suggested that we do live in a simulation and that the speed of light is its outer limit. I left school at 15 and never passed a major exam in my life while the writer was up to his eyes in qualifications. As I will explain in the final chapter *knowing* is far better than thinking and they come from very different sources. The article rightly connected the speed of light to the processing speed of the 'Matrix' and said what has been in my books all this time ... 'If we are in a simulation, as it appears, then space is an abstract property written in code. It is not real'. No it's not and if we live in a simulation something created it and it wasn't *us*. 'That David Icke says we are manipulated by aliens' – he's crackers.'

## **Wow ...**

The reality that humanity thinks is so real is an illusion. Politicians, governments, scientists, doctors, academics, law enforcement, media, school and university curriculums, on and on, are all founded on a world that *does not exist* except as a simulated prison cell. Is it such a stretch to accept that 'Covid' doesn't exist when our entire 'physical' reality doesn't exist? Revealed here is the knowledge kept under raps in the Cult networks of compartmentalised secrecy to control humanity's sense of reality by inducing the population to believe in a reality that's not real. If it wasn't so tragic in its experiential consequences the whole thing would be hysterically funny. None of this is new to Renegade Minds. Ancient Greek philosopher Plato (about 428 to about 347BC) was a major influence on Gnostic belief and he described the human plight thousands of years ago with his Allegory of the Cave. He told the symbolic story of prisoners living in a cave who had never been outside. They were chained and could only see one wall of the cave while behind them was a fire that they could not see. Figures walked past the fire casting shadows on the prisoners' wall and those moving shadows became their sense of reality. Some prisoners began to study the shadows and were considered experts on them (today's academics and scientists), but what they studied was only an illusion (today's academics and scientists). A prisoner escaped from the cave and saw reality as it really is. When he returned to report this revelation they didn't believe him, called him mad and threatened to kill him if he tried to set them free. Plato's tale is not only a brilliant analogy of the human plight and our illusory reality. It describes, too, the dynamics of the 'Covid' hoax. I have only skimmed the surface of these subjects here. The aim of this book is to crisply connect all essential dots to put what is happening today into its true context. All subject areas and their connections in this chapter are covered in great evidential detail in *Everything You Need To Know, But Have Never Been Told* and *The Answer*.

They say that bewildered people 'can't see the forest for the trees'. Humanity, however, can't see the forest for the *twigs*. The five senses

see only twigs while Renegade Minds can see the forest and it's the forest where the answers lie with the connections that reveals. Breaking free of perceptual programming so the forest can be seen is the way we turn all this around. Not breaking free is how humanity got into this mess. The situation may seem hopeless, but I promise you it's not. We are a perceptual heartbeat from paradise if only we knew.

## CHAPTER TWELVE

### **Escaping Wetiko**

*Life is simply a vacation from the infinite*  
Dean Cavanagh

**R**enegade Minds weave the web of life and events and see common themes in the apparently random. They are always there if you look for them and their pursuit is aided by incredible synchronicity that comes when your mind is open rather than mesmerised by what it thinks it can see.

Infinite awareness is infinite possibility and the more of infinite possibility that we access the more becomes infinitely possible. That may be stating the apparently obvious, but it is a devastatingly-powerful fact that can set us free. We are a point of attention within an infinity of consciousness. The question is how much of that infinity do we choose to access? How much knowledge, insight, awareness, wisdom, do we want to connect with and explore? If your focus is only in the five senses you will be influenced by a fraction of infinite awareness. I mean a range so tiny that it gives new meaning to infinitesimal. Limitation of self-identity and a sense of the possible limit accordingly your range of consciousness. We are what we think we are. Life is what we think it is. The dream is the dreamer and the dreamer is the dream. Buddhist philosophy puts it this way: 'As a thing is viewed, so it appears.' Most humans live in the realm of touch, taste, see, hear, and smell and that's the limit of their sense of the possible and sense of self. Many will follow a religion and speak of a God in his heaven, but their lives are still



dominated by the five senses in their perceptions and actions. The five senses become the arbiter of everything. When that happens all except a smear of infinity is sealed away from influence by the rigid, unyielding, reality bubbles that are the five-sense human or Phantom Self. Archon Cult methodology is to isolate consciousness within five-sense reality – the simulation – and then program that consciousness with a sense of self and the world through a deluge of life-long information designed to instil the desired perception that allows global control. Efforts to do this have increased dramatically with identity politics as identity bubbles are squeezed into the minutiae of five-sense detail which disconnect people even more profoundly from the infinite 'I'.

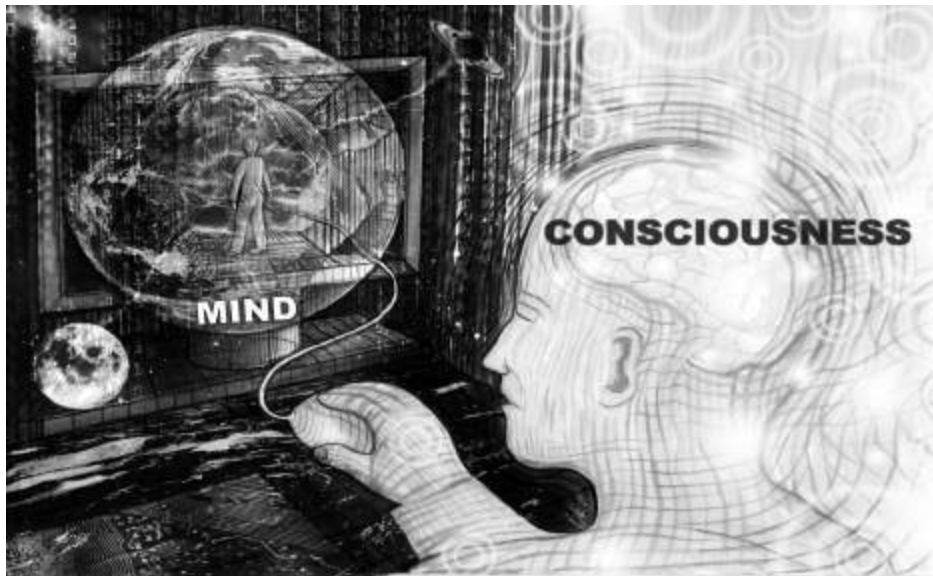
Five-sense focus and self-identity are like a firewall that limits access to the infinite realms. You only perceive one radio or television station and no other. We'll take that literally for a moment. Imagine a vast array of stations giving different information and angles on reality, but you only ever listen to one. Here we have the human plight in which the population is overwhelmingly confined to CultFM. This relates only to the frequency range of CultFM and limits perception and insight to that band – limits *possibility* to that band. It means you are connecting with an almost imperceptibly minuscule range of possibility and creative potential within the infinite Field. It's a world where everything seems apart from everything else and where synchronicity is rare. Synchronicity is defined in the dictionary as 'the happening by chance of two or more related or similar events at the same time'. Use of 'by chance' betrays a complete misunderstanding of reality. Synchronicity is not 'by chance'. As people open their minds, or 'awaken' to use the term, they notice more and more coincidences in their lives, bits of 'luck', apparently miraculous happenings that put them in the right place at the right time with the right people. Days become peppered with 'fancy meeting you here' and 'what are the chances of that?' My entire life has been lived like this and ever more so since my own colossal awakening in 1990 and 91 which transformed my sense of reality. Synchronicity is not 'by chance'; it is by accessing expanded

realms of possibility which allow expanded potential for manifestation. People broadcasting the same vibe from the same openness of mind tend to be drawn 'by chance' to each other through what I call frequency magnetism and it's not only people. In the last more than 30 years incredible synchronicity has also led me through the Cult maze to information in so many forms and to crucial personal experiences. These 'coincidences' have allowed me to put the puzzle pieces together across an enormous array of subjects and situations. Those who have breached the bubble of five-sense reality will know exactly what I mean and this escape from the perceptual prison cell is open to everyone whenever they make that choice. This may appear super-human when compared with the limitations of 'human', but it's really our natural state. 'Human' as currently experienced is consciousness in an unnatural state of induced separation from the infinity of the whole. I'll come to how this transformation into unity can be made when I have described in more detail the force that holds humanity in servitude by denying this access to infinite self.

### **The Wetiko factor**

I have been talking and writing for decades about the way five-sense mind is systematically barricaded from expanded awareness. I have used the analogy of a computer (five-sense mind) and someone at the keyboard (expanded awareness). Interaction between the computer and the operator is symbolic of the interaction between five-sense mind and expanded awareness. The computer directly experiences the Internet and the operator experiences the Internet via the computer which is how it's supposed to be – the two working as one. Archons seek to control that point where the operator connects with the computer to stop that interaction (Fig 20). Now the operator is banging the keyboard and clicking the mouse, but the computer is not responding and this happens when the computer is taken over – *possessed* – by an appropriately-named computer 'virus'. The operator has lost all influence over the computer which goes its own way making decisions under the control of the 'virus'. I have

just described the dynamic through which the force known to Gnostics as Yaldabaoth and Archons disconnects five-sense mind from expanded awareness to imprison humanity in perceptual servitude.



**Figure 20:** The mind ‘virus’ I have been writing about for decades seeks to isolate five-sense mind (the computer) from the true ‘I’. (Image by Neil Hague).

About a year ago I came across a Native American concept of Wetiko which describes precisely the same phenomenon. Wetiko is the spelling used by the Cree and there are other versions including wintiko and windigo used by other tribal groups. They spell the name with lower case, but I see Wetiko as a proper noun as with Archons and prefer a capital. I first saw an article about Wetiko by writer and researcher Paul Levy which so synced with what I had been writing about the computer/operator disconnection and later the Archons. I then read his book, the fascinating *Dispelling Wetiko, Breaking the Spell of Evil*. The parallels between what I had concluded long before and the Native American concept of Wetiko were so clear and obvious that it was almost funny. For Wetiko see the Gnostic Archons for sure and the Jinn, the Predators, and every other name for a force of evil, inversion and chaos. Wetiko is the Native American name for the force that divides the computer from

the operator (Fig 21). Indigenous author Jack D. Forbes, a founder of the Native American movement in the 1960s, wrote another book about Wetiko entitled *Columbus And Other Cannibals – The Wetiko Disease of Exploitation, Imperialism, and Terrorism* which I also read. Forbes says that Wetiko refers to an evil person or spirit ‘who terrorizes other creatures by means of terrible acts, including cannibalism’. Zulu shaman Credo Mutwa told me that African accounts tell how cannibalism was brought into the world by the Chitauri ‘gods’ – another manifestation of Wetiko. The distinction between ‘evil person or spirit’ relates to Archons/Wetiko possessing a human or acting as pure consciousness. Wetiko is said to be a sickness of the soul or spirit and a state of being that takes but gives nothing back – the Cult and its operatives perfectly described. Black Hawk, a Native American war leader defending their lands from confiscation, said European invaders had ‘poisoned hearts’ – Wetiko hearts – and that this would spread to native societies. Mention of the heart is very significant as we shall shortly see. Forbes writes: ‘Tragically, the history of the world for the past 2,000 years is, in great part, the story of the epidemiology of the wetiko disease.’ Yes, and much longer. Forbes is correct when he says: ‘The wetikos destroyed Egypt and Babylon and Athens and Rome and Tenochtitlan [capital of the Aztec empire] and perhaps now they will destroy the entire earth.’ Evil, he said, is the number one export of a Wetiko culture – see its globalisation with ‘Covid’. Constant war, mass murder, suffering of all kinds, child abuse, Satanism, torture and human sacrifice are all expressions of Wetiko and the Wetiko possessed. The world is Wetiko made manifest, *but it doesn’t have to be*. There is a way out of this even now.



**Figure 21:** The mind 'virus' is known to Native Americans as 'Wetiko'. (Image by Neil Hague).

## **Cult of Wetiko**

Wetiko is the Yaldabaoth frequency distortion that seeks to attach to human consciousness and absorb it into its own. Once this connection is made Wetiko can drive the perceptions of the target which they believe to be coming from their own mind. All the horrors of history and today from mass killers to Satanists, paedophiles like Jeffrey Epstein and other psychopaths, are the embodiment of Wetiko and express its state of being in all its grotesqueness. The Cult is Wetiko incarnate, Yaldabaoth incarnate, and it seeks to facilitate Wetiko assimilation of humanity in totality into its distortion by manipulating the population into low frequency states that match its own. Paul Levy writes: 'Holographically enforced within the psyche of every human being the wetiko virus pervades and underlies the entire field of consciousness, and can therefore potentially manifest through any one of us at any moment if we are not mindful.' The 'Covid' hoax has achieved this with many people, but others have not fallen into Wetiko's frequency lair. Players in the 'Covid' human catastrophe including Gates, Schwab, Tedros, Fauci, Whitty, Vallance, Johnson, Hancock, Ferguson, Drosten, and all the rest, including the psychopath psychologists, are expressions of Wetiko. This is why

they have no compassion or empathy and no emotional consequence for what they do that would make them stop doing it. Observe all the people who support the psychopaths in authority against the Pushbackers despite the damaging impact the psychopaths have on their own lives and their family's lives. You are again looking at Wetiko possession which prevents them seeing through the lies to the obvious scam going on. *Why can't they see it?* Wetiko won't let them see it. The perceptual divide that has now become a chasm is between the Wetikoed and the non-Wetikoed.

Paul Levy describes Wetiko in the same way that I have long described the Archontic force. They are the same distorted consciousness operating across dimensions of reality: '... the subtle body of wetiko is not located in the third dimension of space and time, literally existing in another dimension ... it is able to affect ordinary lives by mysteriously interpenetrating into our three-dimensional world.' Wetiko does this through its incarnate representatives in the Cult and by weaving itself into The Field which on our level of reality is the electromagnetic information field of the simulation or Matrix. More than that, the simulation *is* Wetiko / Yaldabaoth. Caleb Scharf, Director of Astrobiology at Columbia University, has speculated that 'alien life' could be so advanced that it has transcribed itself into the quantum realm to become what we call physics. He said intelligence indistinguishable from the fabric of the Universe would solve many of its greatest mysteries:

Perhaps hyper-advanced life isn't just external. Perhaps it's already all around. It is embedded in what we perceive to be physics itself, from the root behaviour of particles and fields to the phenomena of complexity and emergence ... In other words, life might not just be in the equations. It might BE the equations [My emphasis].

Scharf said it is possible that 'we don't recognise advanced life because it forms an integral and unsuspecting part of what we've considered to be the natural world'. I agree. Wetiko/Yaldabaoth *is* the simulation. We are literally in the body of the beast. But that doesn't mean it has to control us. We all have the power to overcome Wetiko

influence and the Cult knows that. I doubt it sleeps too well because it knows that.

## **Which Field?**

This, I suggest, is how it all works. There are two Fields. One is the fierce electromagnetic light of the Matrix within the speed of light; the other is the 'watery light' of The Field beyond the walls of the Matrix that connects with the Great Infinity. Five-sense mind and the decoding systems of the body attach us to the Field of Matrix light. They have to or we could not experience this reality. Five-sense mind sees only the Matrix Field of information while our expanded consciousness is part of the Infinity Field. When we open our minds, and most importantly our hearts, to the Infinity Field we have a mission control which gives us an expanded perspective, a road map, to understand the nature of the five-sense world. If we are isolated only in five-sense mind there is no mission control. We're on our own trying to understand a world that's constantly feeding us information to ensure we do not understand. People in this state can feel 'lost' and bewildered with no direction or radar. You can see ever more clearly those who are influenced by the Fields of Big Infinity or little five-sense mind simply by their views and behaviour with regard to the 'Covid' hoax. We have had this division throughout known human history with the mass of the people on one side and individuals who could see and intuit beyond the walls of the simulation – Plato's prisoner who broke out of the cave and saw reality for what it is. Such people have always been targeted by Wetiko/Archon-possessed authority, burned at the stake or demonised as mad, bad and dangerous. The Cult today and its global network of 'anti-hate', 'anti-fascist' Woke groups are all expressions of Wetiko attacking those exposing the conspiracy, 'Covid' lies and the 'vaccine' agenda.

Woke as a whole is Wetiko which explains its black and white mentality and how at one it is with the Wetiko-possessed Cult. Paul Levy said: 'To be in this paradigm is to still be under the thrall of a two-valued logic – where things are either true or false – of a

wetikoized mind.’ Wetiko consciousness is in a permanent rage, therefore so is Woke, and then there is Woke inversion and contradiction. ‘Anti-fascists’ act like fascists because fascists *and* ‘anti-fascists’ are both Wetiko at work. Political parties act the same while claiming to be different for the same reason. Secret society and satanic rituals are attaching initiates to Wetiko and the cold, ruthless, psychopathic mentality that secures the positions of power all over the world is Wetiko. Reframing ‘training programmes’ have the same cumulative effect of attaching Wetiko and we have their graduates described as automatons and robots with a cold, psychopathic, uncaring demeanour. They are all traits of Wetiko possession and look how many times they have been described in this book and elsewhere with regard to personnel behind ‘Covid’ including the police and medical profession. Climbing the greasy pole in any profession in a Wetiko society requires traits of Wetiko to get there and that is particularly true of politics which is not about fair competition and pre-eminence of ideas. It is founded on how many backs you can stab and arses you can lick. This culminated in the global ‘Covid’ coordination between the Wetiko possessed who pulled it off in all the different countries without a trace of empathy and compassion for their impact on humans. Our sight sense can see only holographic form and not the Field which connects holographic form. Therefore we perceive ‘physical’ objects with ‘space’ in between. In fact that ‘space’ is energy/consciousness operating on multiple frequencies. One of them is Wetiko and that connects the Cult psychopaths, those who submit to the psychopaths, and those who serve the psychopaths in the media operations of the world. Wetiko is Gates. Wetiko is the mask-wearing submissive. Wetiko is the fake journalist and ‘fact-checker’. The Wetiko Field is coordinating the whole thing. Psychopaths, gofers, media operatives, ‘anti-hate’ hate groups, ‘fact-checkers’ and submissive people work as one unit *even without human coordination* because they are attached to the *same* Field which is organising it all (Fig 22). Paul Levy is here describing how Wetiko-possessed people are drawn together and refuse to let any information breach their rigid

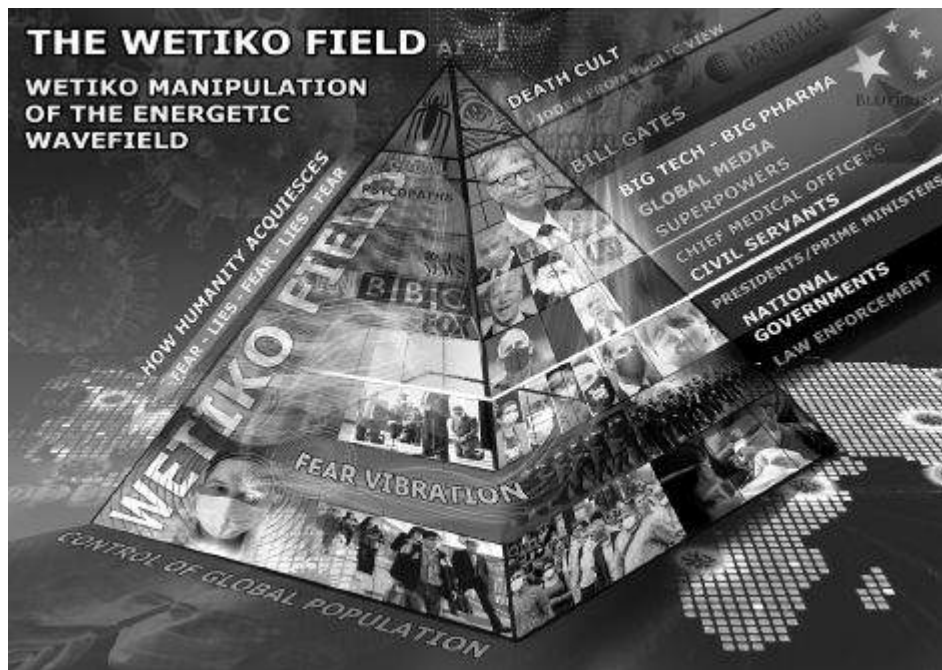


perceptions. He was writing long before 'Covid', but I think you will recognise followers of the 'Covid' religion *oh just a little bit*:

People who are channelling the vibratory frequency of wetiko align with each other through psychic resonance to reinforce their unspoken shared agreement so as to uphold their deranged view of reality. Once an unconscious content takes possession of certain individuals, it irresistibly draws them together by mutual attraction and knits them into groups tied together by their shared madness that can easily swell into an avalanche of insanity.

A psychic epidemic is a closed system, which is to say that it is insular and not open to any new information or informing influences from the outside world which contradict its fixed, limited, and limiting perspective.

There we have the Woke mind and the 'Covid' mind. Compatible resonance draws the awakening together, too, which is clearly happening today.



**Figure 22:** The Wetiko Field from which the Cult pyramid and its personnel are made manifest. (Image by Neil Hague).

## **Spiritual servitude**

Wetiko doesn't care about humans. It's not human; it just possesses humans for its own ends and the effect (depending on the scale of

possession) can be anything from extreme psychopathy to unquestioning obedience. Wetiko's worst nightmare is for human consciousness to expand beyond the simulation. Everything is focussed on stopping that happening through control of information, thus perception, thus frequency. The 'education system', media, science, medicine, academia, are all geared to maintaining humanity in five-sense servitude as is the constant stimulation of low-vibrational mental and emotional states (see 'Covid'). Wetiko seeks to dominate those subconscious spaces between five-sense perception and expanded consciousness where the computer meets the operator. From these subconscious hiding places Wetiko speaks to us to trigger urges and desires that we take to be our own and manipulate us into anything from low-vibrational to psychopathic states. Remember how Islam describes the Jinn as invisible tricksters that 'whisper' and confuse. Wetiko is the origin of the 'trickster god' theme that you find in cultures all over the world. Jinn, like the Archons, are Wetiko which is terrified of humans awakening and reconnecting with our true self for then its energy source has gone. With that the feedback loop breaks between Wetiko and human perception that provides the energetic momentum on which its very existence depends as a force of evil. Humans are both its target and its source of survival, but only if we are operating in low-vibrational states of fear, hate, depression and the background anxiety that most people suffer. We are Wetiko's target because we are its key to survival. It needs us, not the other way round. Paul Levy writes:

A vampire has no intrinsic, independent, substantial existence in its own right; it only exists in relation to us. The pathogenic, vampiric mind-parasite called wetiko is nothing in itself – not being able to exist from its own side – yet it has a 'virtual reality' such that it can potentially destroy our species ...

...The fact that a vampire is not reflected by a mirror can also mean that what we need to see is that there's nothing, no-thing to see, other than ourselves. The fact that wetiko is the expression of something inside of us means that the cure for wetiko is with us as well. The critical issue is finding this cure within us and then putting it into effect.

Evil begets evil because if evil does not constantly expand and find new sources of energetic sustenance its evil, its *distortion*, dies with the assimilation into balance and harmony. Love is the garlic to Wetiko's vampire. Evil, the absence of love, cannot exist in the presence of love. I think I see a way out of here. I have emphasised so many times over the decades that the Archons/Wetiko and their Cult are not all powerful. *They are not*. I don't care how it looks even now *they are not*. I have not called them little boys in short trousers for effect. I have said it because it is true. Wetiko's insatiable desire for power over others is not a sign of its omnipotence, but its insecurity. Paul Levy writes: 'Due to the primal fear which ultimately drives it and which it is driven to cultivate, wetiko's body politic has an intrinsic and insistent need for centralising power and control so as to create imagined safety for itself.' *Yeaaaaees!* Exactly! Why does Wetiko want humans in an ongoing state of fear? Wetiko itself *is* fear and it is petrified of love. As evil is an absence of love, so love is an absence of fear. Love conquers all and *especially* Wetiko which *is* fear. Wetiko brought fear into the world when it wasn't here before. *Fear* was the 'fall', the fall into low-frequency ignorance and illusion – fear is **False Emotion Appearing Real**. The simulation is driven and energised by fear because Wetiko/Yaldabaoth (fear) *are* the simulation. Fear is the absence of love and Wetiko is the absence of love.

## **Wetiko today**

We can now view current events from this level of perspective. The 'Covid' hoax has generated momentous amounts of ongoing fear, anxiety, depression and despair which have empowered Wetiko. No wonder people like Gates have been the instigators when they are Wetiko incarnate and exhibit every trait of Wetiko in the extreme. See how cold and unemotional these people are like Gates and his cronies, how dead of eye they are. That's Wetiko. Sabbatians are Wetiko and everything they control including the World Health Organization, Big Pharma and the 'vaccine' makers, national 'health'

hierarchies, corporate media, Silicon Valley, the banking system, and the United Nations with its planned transformation into world government. All are controlled and possessed by the Wetiko distortion into distorting human society in its image. We are with this knowledge at the gateway to understanding the world. Divisions of race, culture, creed and sexuality are diversions to hide the real division between those possessed and influenced by Wetiko and those that are not. The 'Covid' hoax has brought both clearly into view. Human behaviour is not about race. Tyrants and dictatorships come in all colours and creeds. What unites the US president bombing the innocent and an African tribe committing genocide against another as in Rwanda? What unites them? *Wetiko*. All wars are Wetiko, all genocide is Wetiko, all hunger over centuries in a world of plenty is Wetiko. Children going to bed hungry, including in the West, is Wetiko. Cult-generated Woke racial divisions that focus on the body are designed to obscure the reality that divisions in behaviour are manifestations of mind, not body. Obsession with body identity and group judgement is a means to divert attention from the real source of behaviour – mind and perception. Conflict sown by the Woke both within themselves and with their target groups are Wetiko providing lunch for itself through still more agents of the division, chaos, and fear on which it feeds. The Cult is seeking to assimilate the entirety of humanity and all children and young people into the Wetiko frequency by manipulating them into states of fear and despair. Witness all the suicide and psychological unravelling since the spring of 2020. Wetiko psychopaths want to impose a state of unquestioning obedience to authority which is no more than a conduit for Wetiko to enforce its will and assimilate humanity into itself. It needs us to believe that resistance is futile when it fears resistance and even more so the game-changing non-cooperation with its impositions. It can use violent resistance for its benefit. Violent impositions and violent resistance are *both* Wetiko. The Power of Love with its Power of No will sweep Wetiko from our world. Wetiko and its Cult know that. They just don't want us to know.

## **AI Wetiko**

This brings me to AI or artificial intelligence and something else Wetikos don't want us to know. What is AI *really*? I know about computer code algorithms and AI that learns from data input. These, however, are more diversions, the expeditionary force, for the real AI that they want to connect to the human brain as promoted by Silicon Valley Wetikos like Kurzweil. What is this AI? It is the frequency of *Wetiko*, the frequency of the Archons. The connection of AI to the human brain is the connection of the Wetiko frequency to create a Wetiko hive mind and complete the job of assimilation. The hive mind is planned to be controlled from Israel and China which are both 100 percent owned by Wetiko Sabbatians. The assimilation process has been going on minute by minute in the 'smart' era which fused with the 'Covid' era. We are told that social media is scrambling the minds of the young and changing their personality. This is true, but what is social media? Look more deeply at how it works, how it creates divisions and conflict, the hostility and cruelty, the targeting of people until they are destroyed. That's Wetiko. Social media is manipulated to tune people to the Wetiko frequency with all the emotional exploitation tricks employed by platforms like Facebook and its Wetiko front man, Zuckerberg. Facebook's Instagram announced a new platform for children to overcome a legal bar on them using the main site. This is more Wetiko exploitation and manipulation of kids. Amnesty International likened the plan to foxes offering to guard the henhouse and said it was incompatible with human rights. Since when did Wetiko or Zuckerberg (I repeat myself) care about that? Would Brin and Page at Google, Wojcicki at YouTube, Bezos at Amazon and whoever the hell runs Twitter act as they do if they were not channelling Wetiko? Would those who are developing technologies for no other reason than human control? How about those designing and selling technologies to kill people and Big Pharma drug and 'vaccine' producers who know they will end or devastate lives? Quite a thought for these people to consider is that if you are Wetiko in a human life you are Wetiko on the 'other side' unless your frequency

changes and that can only change by a change of perception which becomes a change of behaviour. Where Gates is going does not bear thinking about although perhaps that's exactly where he wants to go. Either way, that's where he's going. His frequency will make it so.

## **The frequency lair**

I have been saying for a long time that a big part of the addiction to smartphones and devices is that a frequency is coming off them that entraps the mind. People spend ages on their phones and sometimes even a minute or so after they put them down they pick them up again and it all repeats. 'Covid' lockdowns will have increased this addiction a million times for obvious reasons. Addictions to alcohol overindulgence and drugs are another way that Wetiko entraps consciousness to attach to its own. Both are symptoms of low-vibrational psychological distress which alcoholism and drug addiction further compound. Do we think it's really a coincidence that access to them is made so easy while potions that can take people into realms beyond the simulation are banned and illegal? I have explored smartphone addiction in other books, the scale is mind-blowing, and that level of addiction does not come without help. Tech companies that make these phones are Wetiko and they will have no qualms about destroying the minds of children. We are seeing again with these companies the Wetiko perceptual combination of psychopathic enforcers and weak and meek unquestioning compliance by the rank and file.

The global Smart Grid is the Wetiko Grid and it is crucial to complete the Cult endgame. The simulation is radiation and we are being deluged with technological radiation on a devastating scale. Wetiko frauds like Elon Musk serve Cult interests while occasionally criticising them to maintain his street-cred. 5G and other forms of Wi-Fi are being directed at the earth from space on a volume and scale that goes on increasing by the day. Elon Musk's (officially) SpaceX Starlink project is in the process of putting tens of thousands of satellites in low orbit to cover every inch of the planet with 5G and other Wi-Fi to create Kurzweil's global 'cloud' to which the

human mind is planned to be attached very soon. SpaceX has approval to operate 12,000 satellites with more than 1,300 launched at the time of writing and applications filed for 30,000 more. Other operators in the Wi-Fi, 5G, low-orbit satellite market include OneWeb (UK), Telesat (Canada), and AST & Science (US). Musk tells us that AI could be the end of humanity and then launches a company called Neuralink to connect the human brain to computers. Musk's (in theory) Tesla company is building electric cars and the driverless vehicles of the smart control grid. As frauds and bullshitters go Elon Musk in my opinion is Major League.

5G and technological radiation in general are destructive to human health, genetics and psychology and increasing the strength of artificial radiation underpins the five-sense perceptual bubbles which are themselves expressions of radiation or electromagnetism. Freedom activist John Whitehead was so right with his 'databit by databit, we are building our own electronic concentration camps'. The Smart Grid and 5G is a means to control the human mind and infuse perceptual information into The Field to influence anyone in sync with its frequency. You can change perception and behaviour en masse if you can manipulate the population into those levels of frequency and this is happening all around us today. The arrogance of Musk and his fellow Cult operatives knows no bounds in the way that we see with Gates. Musk's satellites are so many in number already they are changing the night sky when viewed from Earth. The astronomy community has complained about this and they have seen nothing yet. Some consequences of Musk's Wetiko hubris include: Radiation; visible pollution of the night sky; interference with astronomy and meteorology; ground and water pollution from intensive use of increasingly many spaceports; accumulating space debris; continual deorbiting and burning up of aging satellites, polluting the atmosphere with toxic dust and smoke; and ever-increasing likelihood of collisions. A collective public open letter of complaint to Musk said:

We are writing to you ... because SpaceX is in process of surrounding the Earth with a network of thousands of satellites whose very purpose is to irradiate every square inch of the

Earth. SpaceX, like everyone else, is treating the radiation as if it were not there. As if the mitochondria in our cells do not depend on electrons moving undisturbed from the food we digest to the oxygen we breathe.

As if our nervous systems and our hearts are not subject to radio frequency interference like any piece of electronic equipment. As if the cancer, diabetes, and heart disease that now afflict a majority of the Earth's population are not metabolic diseases that result from interference with our cellular machinery. As if insects everywhere, and the birds and animals that eat them, are not starving to death as a result.

People like Musk and Gates believe in their limitless Wetiko arrogance that they can do whatever they like to the world because they own it. Consequences for humanity are irrelevant. It's absolutely time that we stopped taking this shit from these self-styled masters of the Earth when you consider where this is going.

## **Why is the Cult so anti-human?**

I hear this question often: Why would they do this when it will affect them, too? Ah, but will it? Who is this *them*? Forget their bodies. They are just vehicles for Wetiko consciousness. When you break it all down to the foundations we are looking at a state of severely distorted consciousness targeting another state of consciousness for assimilation. The rest is detail. The simulation is the fly-trap in which unique sensations of the five senses create a cycle of addiction called reincarnation. Renegade Minds see that everything which happens in our reality is a smaller version of the whole picture in line with the holographic principle. Addiction to the radiation of smart technology is a smaller version of addiction to the whole simulation. Connecting the body/brain to AI is taking that addiction on a giant step further to total ongoing control by assimilating human incarnate consciousness into Wetiko. I have watched during the 'Covid' hoax how many are becoming ever more profoundly attached to Wetiko's perceptual calling cards of aggressive response to any other point of view ('There is no other god but me'), psychopathic lack of compassion and empathy, and servile submission to the narrative and will of authority. Wetiko is the psychopaths *and* subservience to psychopaths. The Cult of Wetiko is



so anti-human because it is *not* human. It embarked on a mission to destroy human by targeting everything that it means to be human and to survive as human. 'Covid' is not the end, just a means to an end. The Cult with its Wetiko consciousness is seeking to change Earth systems, including the atmosphere, to suit them, not humans. The gathering bombardment of 5G alone from ground and space is dramatically changing The Field with which the five senses interact. There is so much more to come if we sit on our hands and hope it will all go away. It is not meant to go away. It is meant to get ever more extreme and we need to face that while we still can – just.

Carbon dioxide is the gas of life. Without that human is over. Kaput, gone, history. No natural world, no human. The Cult has created a cock and bull story about carbon dioxide and climate change to justify its reduction to the point where Gates and the ignoramus Biden 'climate chief' John Kerry want to suck it out of the atmosphere. Kerry wants to do this because his master Gates does. Wetikos have made the gas of life a demon with the usual support from the Wokers of Extinction Rebellion and similar organisations and the bewildered puppet-child that is Greta Thunberg who was put on the world stage by Klaus Schwab and the World Economic Forum. The name Extinction Rebellion is both ironic and as always Wetiko inversion. The gas that we need to survive must be reduced to save us from extinction. The most basic need of human is oxygen and we now have billions walking around in face nappies depriving body and brain of this essential requirement of human existence. More than that 5G at 60 gigahertz interacts with the oxygen molecule to reduce the amount of oxygen the body can absorb into the bloodstream. The obvious knock-on consequences of that for respiratory and cognitive problems and life itself need no further explanation. Psychopaths like Musk are assembling a global system of satellites to deluge the human atmosphere with this insanity. The man should be in jail. Here we have two most basic of human needs, oxygen and carbon dioxide, being dismantled.

Two others, water and food, are getting similar treatment with the United Nations Agendas 21 and 2030 – the Great Reset – planning to

centrally control all water and food supplies. People will not even own rain water that falls on their land. Food is affected at the most basic level by reducing carbon dioxide. We have genetic modification or GMO infiltrating the food chain on a mass scale, pesticides and herbicides polluting the air and destroying the soil. Freshwater fish that provide livelihoods for 60 million people and feed hundreds of millions worldwide are being 'pushed to the brink' according the conservationists while climate change is the only focus. Now we have Gates and Schwab wanting to dispense with current food sources all together and replace them with a synthetic version which the Wetiko Cult would control in terms of production and who eats and who doesn't. We have been on the Totalitarian Tiptoe to this for more than 60 years as food has become ever more processed and full of chemical shite to the point today when it's not natural food at all. As Dr Tom Cowan says: 'If it has a label don't eat it.' Bill Gates is now the biggest owner of farmland in the United States and he does nothing without an ulterior motive involving the Cult. Klaus Schwab wrote: 'To feed the world in the next 50 years we will need to produce as much food as was produced in the last 10,000 years ... food security will only be achieved, however, if regulations on genetically modified foods are adapted to reflect the reality that gene editing offers a precise, efficient and safe method of improving crops.' Liar. People and the world are being targeted with aluminium through vaccines, chemtrails, food, drink cans, and endless other sources when aluminium has been linked to many health issues including dementia which is increasing year after year. Insects, bees and wildlife essential to the food chain are being deleted by pesticides, herbicides and radiation which 5G is dramatically increasing with 6G and 7G to come. The pollinating bee population is being devastated while wildlife including birds, dolphins and whales are having their natural radar blocked by the effects of ever-increasing radiation. In the summer windscreens used to be splattered with insects so numerous were they. It doesn't happen now. Where have they gone?

## **Synthetic everything**

The Cult is introducing genetically-modified versions of trees, plants and insects including a Gates-funded project to unleash hundreds of millions of genetically-modified, lab-altered and patented male mosquitoes to mate with wild mosquitoes and induce genetic flaws that cause them to die out. Clinically-insane Gates-funded Japanese researchers have developed mosquitos that spread vaccine and are dubbed 'flying vaccinators'. Gates is funding the modification of weather patterns in part to sell the myth that this is caused by carbon dioxide and he's funding geoengineering of the skies to change the atmosphere. Some of this came to light with the Gates-backed plan to release tonnes of chalk into the atmosphere to 'deflect the Sun and cool the planet'. Funny how they do this while the heating effect of the Sun is not factored into climate projections focussed on carbon dioxide. The reason is that they want to reduce carbon dioxide (so don't mention the Sun), but at the same time they do want to reduce the impact of the Sun which is so essential to human life and health. I have mentioned the sun-cholesterol-vitamin D connection as they demonise the Sun with warnings about skin cancer (caused by the chemicals in sun cream they tell you to splash on). They come from the other end of the process with statin drugs to reduce cholesterol that turns sunlight into vitamin D. A lack of vitamin D leads to a long list of health effects and how vitamin D levels must have fallen with people confined to their homes over 'Covid'. Gates is funding other forms of geoengineering and most importantly chemtrails which are dropping heavy metals, aluminium and self-replicating nanotechnology onto the Earth which is killing the natural world. See *Everything You Need To Know, But Have Never Been Told* for the detailed background to this.

Every human system is being targeted for deletion by a force that's not human. The Wetiko Cult has embarked on the process of transforming the human body from biological to synthetic biological as I have explained. Biological is being replaced by the artificial and synthetic – Archontic 'countermimicry' – right across human society. The plan eventually is to dispense with the human body altogether

and absorb human consciousness – which it wouldn't really be by then – into cyberspace (the simulation which is Wetiko/Yaldabaoth). Preparations for that are already happening if people would care to look. The alternative media rightly warns about globalism and 'the globalists', but this is far bigger than that and represents the end of the human race as we know it. The 'bad copy' of prime reality that Gnostics describe was a bad copy of harmony, wonder and beauty to start with before Wetiko/Yaldabaoth set out to change the simulated 'copy' into something very different. The process was slow to start with. Entrapped humans in the simulation timeline were not technologically aware and they had to be brought up to intellectual speed while being suppressed spiritually to the point where they could build their own prison while having no idea they were doing so. We have now reached that stage where technological intellect has the potential to destroy us and that's why events are moving so fast. Central American shaman Don Juan Matus said:

Think for a moment, and tell me how you would explain the contradictions between the intelligence of man the engineer and the stupidity of his systems of belief, or the stupidity of his contradictory behaviour. Sorcerers believe that the predators have given us our systems of beliefs, our ideas of good and evil; our social mores. They are the ones who set up our dreams of success or failure. They have given us covetousness, greed, and cowardice. It is the predator who makes us complacent, routinary, and egomaniacal.

In order to keep us obedient and meek and weak, the predators engaged themselves in a stupendous manoeuvre – stupendous, of course, from the point of view of a fighting strategist; a horrendous manoeuvre from the point of those who suffer it. They gave us their mind. The predators' mind is baroque, contradictory, morose, filled with the fear of being discovered any minute now.

For 'predators' see Wetiko, Archons, Yaldabaoth, Jinn, and all the other versions of the same phenomenon in cultures and religions all over the world. The theme is always the same because it's true and it's real. We have reached the point where we have to deal with it. The question is – how?

**Don't fight – walk away**

I thought I'd use a controversial subheading to get things moving in terms of our response to global fascism. What do you mean 'don't fight'? What do you mean 'walk away'? We've got to fight. We can't walk away. Well, it depends what we mean by fight and walk away. If fighting means physical combat we are playing Wetiko's game and falling for its trap. It wants us to get angry, aggressive, and direct hate and hostility at the enemy we think we must fight. Every war, every battle, every conflict, has been fought with Wetiko leading both sides. It's what it does. Wetiko wants a fight, anywhere, any place. Just hit me, son, so I can hit you back. Wetiko hits Wetiko and Wetiko hits Wetiko in return. I am very forthright as you can see in exposing Wetikos of the Cult, but I don't hate them. I refuse to hate them. It's what they want. What you hate you become. What you *fight* you become. Wokers, 'anti-haters' and 'anti-fascists' prove this every time they reach for their keyboards or don their balaclavas. By walk away I mean to disengage from Wetiko which includes ceasing to cooperate with its tyranny. Paul Levy says of Wetiko:

The way to 'defeat' evil is not to try to destroy it (for then, in playing evil's game, we have already lost), but rather, to find the invulnerable place within ourselves where evil is unable to vanquish us – this is to truly 'win' our battle with evil.

Wetiko is everywhere in human society and it's been on steroids since the 'Covid' hoax. Every shouting match over wearing masks has Wetiko wearing a mask and Wetiko not wearing one. It's an electrical circuit of push and resist, push and resist, with Wetiko pushing *and* resisting. Each polarity is Wetiko empowering itself. Dictionary definitions of 'resist' include 'opposing, refusing to accept or comply with' and the word to focus on is 'opposing'. What form does this take – setting police cars alight or 'refusing to accept or comply with'? The former is Wetiko opposing Wetiko while the other points the way forward. This is the difference between those aggressively demanding that government fascism must be obeyed who stand in stark contrast to the great majority of Pushbackers. We saw this clearly with a march by thousands of Pushbackers against lockdown in London followed days later by a Woker-hijacked

protest in Bristol in which police cars were set on fire. Masks were virtually absent in London and widespread in Bristol. Wetiko wants lockdown on every level of society and infuses its aggression to police it through its unknowing stooges. Lockdown protesters are the ones with the smiling faces and the hugs, The two blatantly obvious states of being – getting more obvious by the day – are the result of Wokers and their like becoming ever more influenced by the simulation Field of Wetiko and Pushbackers ever more influenced by The Field of a far higher vibration beyond the simulation. Wetiko can't invade the heart which is where most lockdown opponents are coming from. It's the heart that allows them to see through the lies to the truth in ways I will be highlighting.

Renegade Minds know that calmness is the place from which wisdom comes. You won't find wisdom in a hissing fit and wisdom is what we need in abundance right now. Calmness is not weakness – you don't have to scream at the top of your voice to be strong. Calmness is indeed a sign of strength. 'No' means I'm not doing it. NOOOO!!! doesn't mean you're not doing it even more. Volume does not advance 'No – I'm not doing it'. You are just not doing it. Wetiko possessed and influenced don't know how to deal with that. Wetiko wants a fight and we should not give it one. What it needs more than anything is our *cooperation* and we should not give that either. Mass rallies and marches are great in that they are a visual representation of feeling, but if it ends there they are irrelevant. You demand that Wetikos act differently? Well, they're not going to are they? They are Wetikos. We don't need to waste our time demanding that something doesn't happen when that will make no difference. We need to delete the means that *allows* it to happen. This, invariably, is our cooperation. You can demand a child stop firing a peashooter at the dog or you can refuse to buy the peashooter. If you provide the means you are cooperating with the dog being smacked on the nose with a pea. How can the authorities enforce mask-wearing if millions in a country refuse? What if the 74 million Pushbackers that voted for Trump in 2020 refused to wear masks, close their businesses or stay in their homes. It would be unenforceable. The

few control the many through the compliance of the many and that's always been the dynamic be it 'Covid' regulations or the Roman Empire. I know people can find it intimidating to say no to authority or stand out in a crowd for being the only one with a face on display; but it has to be done or it's over. I hope I've made clear in this book that where this is going will be far more intimidating than standing up now and saying 'No' – I will not cooperate with my own enslavement and that of my children. There might be consequences for some initially, although not so if enough do the same. The question that must be addressed is what is going to happen if we don't? It is time to be strong and unyieldingly so. No means no. Not here and there, but *everywhere* and *always*. I have refused to wear a mask and obey all the other nonsense. I will not comply with tyranny. I repeat: Fascism is not imposed by fascists – there are never enough of them. Fascism is imposed by the population acquiescing to fascism. *I will not do it*. I will die first, or my body will. Living meekly under fascism is a form of death anyway, the death of the spirit that Martin Luther King described.

## **Making things happen**

We must not despair. This is not over till it's over and it's far from that. The 'fat lady' must refuse to sing. The longer the 'Covid' hoax has dragged on and impacted on more lives we have seen an awakening of phenomenal numbers of people worldwide to the realisation that what they have believed all their lives is not how the world really is. Research published by the system-serving University of Bristol and King's College London in February, 2021, concluded: 'One in every 11 people in Britain say they trust David Icke's take on the coronavirus pandemic.' It will be more by now and we have gathering numbers to build on. We must urgently progress from seeing the scam to ceasing to cooperate with it. Prominent German lawyer Reiner Fuellmich, also licenced to practice law in America, is doing a magnificent job taking the legal route to bring the psychopaths to justice through a second Nuremberg tribunal for crimes against humanity. Fuellmich has an impressive record of

beating the elite in court and he formed the German Corona Investigative Committee to pursue civil charges against the main perpetrators with a view to triggering criminal charges. Most importantly he has grasped the foundation of the hoax – the PCR test not testing for the ‘virus’ – and Christian Drosten is therefore on his charge sheet along with Gates frontman Tedros at the World Health Organization. Major players must not be allowed to inflict their horrors on the human race without being brought to book. A life sentence must follow for Bill Gates and the rest of them. A group of researchers has also indicted the government of Norway for crimes against humanity with copies sent to the police and the International Criminal Court. The lawsuit cites participation in an internationally-planned false pandemic and violation of international law and human rights, the European Commission’s definition of human rights by coercive rules, Nuremberg and Hague rules on fundamental human rights, and the Norwegian constitution. We must take the initiative from hereon and not just complain, protest and react.

There are practical ways to support vital mass non-cooperation. Organising in numbers is one. Lockdown marches in London in the spring in 2021 were mass non-cooperation that the authorities could not stop. There were too many people. Hundreds of thousands walked the London streets in the centre of the road for mile after mile while the Face-Nappies could only look on. They were determined, but calm, and just *did it* with no histrionics and lots of smiles. The police were impotent. Others are organising group shopping without masks for mutual support and imagine if that was happening all over. Policing it would be impossible. If the store refuses to serve people in these circumstances they would be faced with a long line of trolleys full of goods standing on their own and everything would have to be returned to the shelves. How would they cope with that if it kept happening? I am talking here about moving on from complaining to being pro-active; from watching things happen to making things happen. I include in this our relationship with the police. The behaviour of many Face-Nappies



has been disgraceful and anyone who thinks they would never find concentration camp guards in the 'enlightened' modern era have had that myth busted big-time. The period and setting may change – Wetikos never do. I watched film footage from a London march in which a police thug viciously kicked a protestor on the floor who had done nothing. His fellow Face-Nappies stood in a ring protecting him. What he did was a criminal assault and with a crowd far outnumbering the police this can no longer be allowed to happen unchallenged. I get it when people chant 'shame on you' in these circumstances, but that is no longer enough. They *have* no shame those who do this. Crowds needs to start making a citizen's arrest of the police who commit criminal offences and brutally attack innocent people and defenceless women. A citizen's arrest can be made under section 24A of the UK Police and Criminal Evidence (PACE) Act of 1984 and you will find something similar in other countries. I prefer to call it a Common Law arrest rather than citizen's for reasons I will come to shortly. Anyone can arrest a person committing an indictable offence or if they have reasonable grounds to suspect they are committing an indictable offence. On both counts the attack by the police thug would have fallen into this category. A citizen's arrest can be made to stop someone:

- Causing physical injury to himself or any other person
- Suffering physical injury
- Causing loss of or damage to property
- Making off before a constable can assume responsibility for him

A citizen's arrest may also be made to prevent a breach of the peace under Common Law and if they believe a breach of the peace will happen or anything related to harm likely to be done or already done in their presence. This is the way to go I think – the Common Law version. If police know that the crowd and members of the public will no longer be standing and watching while they commit

their thuggery and crimes they will think twice about acting like Brownshirts and Blackshirts.

### **Common Law – common sense**

Mention of Common Law is very important. Most people think the law is the law as in one law. This is not the case. There are two bodies of law, Common Law and Statute Law, and they are not the same. Common Law is founded on the simple premise of do no harm. It does not recognise victimless crimes in which no harm is done while Statute Law does. There is a Statute Law against almost everything. So what is Statute Law? Amazingly it's the law of the *sea* that was brought ashore by the Cult to override the law of the land which is Common Law. They had no right to do this and as always they did it anyway. They had to. They could not impose their will on the people through Common Law which only applies to do no harm. How could you stitch up the fine detail of people's lives with that? Instead they took the law of the sea, or Admiralty Law, and applied it to the population. Statute Law refers to all the laws spewing out of governments and their agencies including all the fascist laws and regulations relating to 'Covid'. The key point to make is that Statute Law is *contract law*. It only applies between *contracting* corporations. Most police officers don't even know this. They have to be kept in the dark, too. Long ago when merchants and their sailing ships began to trade with different countries a contractual law was developed called Admiralty Law and other names. Again it only applied to *contracts* agreed between *corporate* entities. If there is no agreed contract the law of the sea had no jurisdiction *and that still applies to its new alias of Statute Law*. The problem for the Cult when the law of the sea was brought ashore was an obvious one. People were not corporations and neither were government entities. To overcome the latter they made governments and all associated organisations corporations. All the institutions are *private corporations* and I mean governments and their agencies, local councils, police, courts, military, US states, the whole lot. Go to the

Dun and Bradstreet corporate listings website for confirmation that they are all corporations. You are arrested by a private corporation called the police by someone who is really a private security guard and they take you to court which is another private corporation. Neither have jurisdiction over you unless you consent and *contract* with them. This is why you hear the mantra about law enforcement policing by *consent* of the people. In truth the people 'consent' only in theory through monumental trickery.

Okay, the Cult overcame the corporate law problem by making governments and institutions corporate entities; but what about people? They are not corporations are they? Ah ... well in a sense, and *only* a sense, they are. Not people exactly – the illusion of people. The Cult creates a corporation in the name of everyone at the time that their birth certificate is issued. Note birth/ *berth* certificate and when you go to court under the law of the sea on land you stand in a *dock*. These are throwbacks to the origin. My Common Law name is David Vaughan Icke. The name of the corporation created by the government when I was born is called Mr David Vaughan Icke usually written in capitals as MR DAVID VAUGHAN ICKE. That is not me, the living, breathing man. It is a fictitious corporate entity. The trick is to make you think that David Vaughan Icke and MR DAVID VAUGHAN ICKE are the same thing. *They are not*. When police charge you and take you to court they are prosecuting the corporate entity and not the living, breathing, man or woman. They have to trick you into identifying as the corporate entity and contracting with them. Otherwise they have no jurisdiction. They do this through a language known as legalese. Lawful and legal are not the same either. Lawful relates to Common Law and legal relates to Statute Law. Legalese is the language of Statue Law which uses terms that mean one thing to the public and another in legalese. Notice that when a police officer tells someone why they are being charged he or she will say at the end: 'Do you understand?' To the public that means 'Do you comprehend?' In legalese it means 'Do you stand under me?' Do you stand under my authority? If you say

yes to the question you are unknowingly agreeing to give them jurisdiction over you in a contract between two corporate entities.

This is a confidence trick in every way. Contracts have to be agreed between informed parties and if you don't know that David Vaughan Icke is agreeing to be the corporation MR DAVID VAUGHAN ICKE you cannot knowingly agree to contract. They are deceiving you and another way they do this is to ask for proof of identity. You usually show them a driving licence or other document on which your corporate name is written. In doing so you are accepting that you are that corporate entity when you are not. Referring to yourself as a 'person' or 'citizen' is also identifying with your corporate fiction which is why I made the Common Law point about the citizen's arrest. If you are approached by a police officer you identify yourself immediately as a living, breathing, man or woman and say 'I do not consent, I do not contract with you and I do not understand' or stand under their authority. I have a Common Law birth certificate as a living man and these are available at no charge from [commonlawcourt.com](http://commonlawcourt.com). Businesses registered under the Statute Law system means that its laws apply. There are, however, ways to run a business under Common Law. Remember all 'Covid' laws and regulations are Statute Law – the law of *contracts* and you do not have to contract. This doesn't mean that you can kill someone and get away with it. Common Law says do no harm and that applies to physical harm, financial harm etc. Police are employees of private corporations and there needs to be a new system of non-corporate Common Law constables operating outside the Statute Law system. If you go to [davidicke.com](http://davidicke.com) and put Common Law into the search engine you will find videos that explain Common Law in much greater detail. It is definitely a road we should walk.

### **With all my heart**

I have heard people say that we are in a spiritual war. I don't like the term 'war' with its Wetiko dynamic, but I know what they mean. Sweep aside all the bodily forms and we are in a situation in which two states of consciousness are seeking very different realities.

Wetiko wants upheaval, chaos, fear, suffering, conflict and control. The other wants love, peace, harmony, fairness and freedom. That's where we are. We should not fall for the idea that Wetiko is all-powerful and there's nothing we can do. Wetiko is not all-powerful. It's a joke, pathetic. It doesn't have to be, but it has made that choice for now. A handful of times over the years when I have felt the presence of its frequency I have allowed it to attach briefly so I could consciously observe its nature. The experience is not pleasant, the energy is heavy and dark, but the ease with which you can kick it back out the door shows that its real power is in persuading us that it has power. It's all a con. Wetiko is a con. It's a trickster and not a power that can control us if we unleash our own. The con is founded on manipulating humanity to give its power to Wetiko which recycles it back to present the illusion that it has power when its power is *ours* that we gave away. This happens on an energetic level and plays out in the world of the seen as humanity giving its power to Wetiko authority which uses that power to control the population when the power is only the power the population has handed over. How could it be any other way for billions to be controlled by a relative few? I have had experiences with people possessed by Wetiko and again you can kick its arse if you do it with an open heart. Oh yes – the *heart* which can transform the world of perceived 'matter'.

We are receiver-transmitters and processors of information, but what information and where from? Information is processed into perception in three main areas – the brain, the heart and the belly. These relate to thinking, knowing, and emotion. Wetiko wants us to be head and belly people which means we think within the confines of the Matrix simulation and low-vibrational emotional reaction scrambles balance and perception. A few minutes on social media and you see how emotion is the dominant force. Woke is all emotion and is therefore thought-free and fact-free. Our heart is something different. It *knows* while the head *thinks* and has to try to work it out because it doesn't know. The human energy field has seven prime vortexes which connect us with wider reality ([Fig 23](#)). Chakra means

'wheels of light' in the Sanskrit language of ancient India. The main ones are: The crown chakra on top of the head; brow (or 'third eye') chakra in the centre of the forehead; throat chakra; heart chakra in the centre of the chest; solar plexus chakra below the sternum; sacral chakra beneath the navel; and base chakra at the bottom of the spine. Each one has a particular function or functions. We feel anxiety and nervousness in the belly where the sacral chakra is located and this processes emotion that can affect the colon to give people 'the shits' or make them 'shit scared' when they are nervous. Chakras all play an important role, but the Mr and Mrs Big is the heart chakra which sits at the centre of the seven, above the chakras that connect us to the 'physical' and below those that connect with higher realms (or at least should). Here in the heart chakra we feel love, empathy and compassion – 'My heart goes out to you'. Those with closed hearts become literally 'heart-less' in their attitudes and behaviour (see Bill Gates). Native Americans portrayed Wetiko with what Paul Levy calls a 'frigid, icy heart, devoid of mercy' (see Bill Gates).



**Figure 23:** The chakra system which interpenetrates the human energy field. The heart chakra is the governor – or should be.

Wetiko trembles at the thought of heart energy which it cannot infiltrate. The frequency is too high. What it seeks to do instead is close the heart chakra vortex to block its perceptual and energetic influence. Psychopaths have 'hearts of stone' and emotionally-damaged people have 'heartache' and 'broken hearts'. The astonishing amount of heart disease is related to heart chakra

disruption with its fundamental connection to the 'physical' heart. Dr Tom Cowan has written an outstanding book challenging the belief that the heart is a pump and making the connection between the 'physical' and spiritual heart. Rudolph Steiner who was way ahead of his time said the same about the fallacy that the heart is a pump. *What?* The heart is not a pump? That's crazy, right? Everybody knows that. Read Cowan's *Human Heart, Cosmic Heart* and you will realise that the very idea of the heart as a pump is ridiculous when you see the evidence. How does blood in the feet so far from the heart get pumped horizontally up the body by the heart?? Cowan explains in the book the real reason why blood moves as it does. Our 'physical' heart is used to symbolise love when the source is really the heart vortex or spiritual heart which is our most powerful energetic connection to 'out there' expanded consciousness. That's why we feel *knowing* – intuitive knowing – in the centre of the chest. Knowing doesn't come from a process of thoughts leading to a conclusion. It is there in an instant all in one go. Our heart knows because of its connection to levels of awareness that *do* know. This is the meaning and source of intuition – intuitive *knowing*.

For the last more than 30 years of uncovering the global game and the nature of reality my heart has been my constant antenna for truth and accuracy. An American intelligence insider once said that I had quoted a disinformant in one of my books and yet I had only quoted the part that was true. He asked: 'How do you do that?' By using my heart antenna was the answer and anyone can do it. Heart-centred is how we are meant to be. With a closed heart chakra we withdraw into a closed mind and the bubble of five-sense reality. If you take a moment to focus your attention on the centre of your chest, picture a spinning wheel of light and see it opening and expanding. You will feel it happening, too, and perceptions of the heart like joy and love as the heart impacts on the mind as they interact. The more the chakra opens the more you will feel expressions of heart consciousness and as the process continues, and becomes part of you, insights and knowings will follow. An open

heart is connected to that level of awareness that knows all is *One*. You will see from its perspective that the fault-lines that divide us are only illusions to control us. An open heart does not process the illusions of race, creed and sexuality except as brief experiences for a consciousness that is all. Our heart does not see division, only unity (Figs 24 and 25). There's something else, too. Our hearts love to laugh. Mark Twain's quote that says 'The human race has one really effective weapon, and that is laughter' is really a reference to the heart which loves to laugh with the joy of knowing the true nature of infinite reality and that all the madness of human society is an illusion of the mind. Twain also said: 'Against the assault of laughter nothing can stand.' This is so true of Wetiko and the Cult. Their insecurity demands that they be taken seriously and their power and authority acknowledged and feared. We should do nothing of the sort. We should not get aggressive or fearful which their insecurity so desires. We should laugh in their face. Even in their no-face as police come over in their face-nappies and expect to be taken seriously. They don't take themselves seriously looking like that so why should we? Laugh in the face of intimidation. Laugh in the face of tyranny. You will see by its reaction that you have pressed all of its buttons. Wetiko does not know what to do in the face of laughter or when its targets refuse to concede their joy to fear. We have seen many examples during the 'Covid' hoax when people have expressed their energetic power and the string puppets of Wetiko retreat with their tail limp between their knees. Laugh – the world is bloody mad after all and if it's a choice between laughter and tears I know which way I'm going.





**Figure 24:** Head consciousness without the heart sees division and everything apart from everything else.



**Figure 25:** Heart consciousness sees everything as One.

## **'Vaccines' and the soul**

The foundation of Wetiko/Archon control of humans is the separation of incarnate five-sense mind from the infinite 'I' and closing the heart chakra where the True 'I' lives during a human life. The goal has been to achieve complete separation in both cases. I was interested therefore to read an account by a French energetic healer of what she said she experienced with a patient who had been given the 'Covid' vaccine. Genuine energy healers can sense information and consciousness fields at different levels of being which are referred to as 'subtle bodies'. She described treating the patient who later returned after having, without the healer's knowledge, two doses of the 'Covid vaccine'. The healer said:

I noticed immediately the change, very heavy energy emanating from [the] subtle bodies. The scariest thing was when I was working on the heart chakra, I connected with her soul: it was detached from the physical body, it had no contact and it was, as if it was floating in a state of total confusion: a damage to the consciousness that loses contact with the physical body, i.e. with our biological machine, there is no longer any communication between them.

I continued the treatment by sending light to the heart chakra, the soul of the person, but it seemed that the soul could no longer receive any light, frequency or energy. It was a very powerful experience for me. Then I understood that this substance is indeed used to detach consciousness so that this consciousness can no longer interact through this body that it possesses in life, where there is no longer any contact, no frequency, no light, no more energetic balance or mind.

This would create a human that is rudderless and at the extreme almost zombie-like operating with a fractional state of consciousness at the mercy of Wetiko. I was especially intrigued by what the healer said in the light of the prediction by the highly-informed Rudolf Steiner more than a hundred years ago. He said:

In the future, we will eliminate the soul with medicine. Under the pretext of a 'healthy point of view', there will be a vaccine by which the human body will be treated as soon as possible directly at birth, so that the human being cannot develop the thought of the existence of soul and Spirit. To materialistic doctors will be entrusted the task of removing the soul of humanity.

As today, people are vaccinated against this disease or that disease, so in the future, children will be vaccinated with a substance that can be produced precisely in such a way that people, thanks to this vaccination, will be immune to being subjected to the 'madness' of spiritual life. He would be extremely smart, but he would not develop a conscience, and that is the true goal of some materialistic circles.

Steiner said the vaccine would detach the physical body from the etheric body (subtle bodies) and 'once the etheric body is detached the relationship between the universe and the etheric body would become extremely unstable, and man would become an automaton'. He said 'the physical body of man must be polished on this Earth by spiritual will – so the vaccine becomes a kind of arymanique (Wetiko) force' and 'man can no longer get rid of a given materialistic feeling'. Humans would then, he said, become 'materialistic of constitution and can no longer rise to the spiritual'. I have been writing for years about DNA being a receiver-transmitter of information that connects us to other levels of reality and these 'vaccines' changing DNA can be likened to changing an antenna and what it can transmit and receive. Such a disconnection would clearly lead to changes in personality and perception. Steiner further predicted the arrival of AI. Big Pharma 'Covid vaccine' makers, expressions of Wetiko, are testing their DNA-manipulating evil on children as I write with a view to giving the 'vaccine' to babies. If it's a soul-body disconnecter – and I say that it is or can be – every child would be disconnected from 'soul' at birth and the 'vaccine' would create a closed system in which spiritual guidance from the greater self would play no part. This has been the ambition of Wetiko all

along. A Pentagon video from 2005 was leaked of a presentation explaining the development of vaccines to change behaviour by their effect on the brain. Those that believe this is not happening with the 'Covid' genetically-modifying procedure masquerading as a 'vaccine' should make an urgent appointment with Naivety Anonymous. Klaus Schwab wrote in 2018:

Neurotechnologies enable us to better influence consciousness and thought and to understand many activities of the brain. They include decoding what we are thinking in fine levels of detail through new chemicals and interventions that can influence our brains to correct for errors or enhance functionality.

The plan is clear and only the heart can stop it. With every heart that opens, every mind that awakens, Wetiko is weakened. Heart and love are far more powerful than head and hate and so nothing like a majority is needed to turn this around.

## **Beyond the Phantom**

Our heart is the prime target of Wetiko and so it must be the answer to Wetiko. We *are* our heart which is part of one heart, the infinite heart. Our heart is where the true self lives in a human life behind firewalls of five-sense illusion when an imposter takes its place – *Phantom Self*; but our heart waits patiently to be set free any time we choose to see beyond the Phantom, beyond Wetiko. A Wetikoed Phantom Self can wreak mass death and destruction while the love of forever is locked away in its heart. The time is here to unleash its power and let it sweep away the fear and despair that is Wetiko. Heart consciousness does not seek manipulated, censored, advantage for its belief or religion, its activism and desires. As an expression of the One it treats all as One with the same rights to freedom and opinion. Our heart demands fairness for itself no more than for others. From this unity of heart we can come together in mutual support and transform this Wetikoed world into what reality is meant to be – a place of love, joy, happiness, fairness, justice and freedom. Wetiko has another agenda and that's why the world is as

it is, but enough of this nonsense. Wetiko can't stay where hearts are open and it works so hard to keep them closed. Fear is its currency and its food source and love in its true sense has no fear. Why would love have fear when it knows it is *All That Is, Has Been, And Ever Can Be* on an eternal exploration of all possibility? Love in this true sense is not the physical attraction that passes for love. This can be an expression of it, yes, but Infinite Love, a love without condition, goes far deeper to the core of all being. It *is* the core of all being. Infinite reality was born from love beyond the illusions of the simulation. Love infinitely expressed is the knowing that all is One and the swiftly-passing experience of separation is a temporary hallucination. You cannot disconnect from Oneness; you can only *perceive* that you have and withdraw from its influence. This is the most important of all perception trickery by the mind parasite that is Wetiko and the foundation of all its potential for manipulation.

If we open our hearts, open the sluice gates of the mind, and redefine self-identity amazing things start to happen. Consciousness expands or contracts in accordance with self-identity. When true self is recognised as infinite awareness and label self – Phantom Self – is seen as only a series of brief experiences life is transformed. Consciousness expands to the extent that self-identity expands and everything changes. You see unity, not division, the picture, not the pixels. From this we can play the long game. No more is an experience something in and of itself, but a fleeting moment in the eternity of forever. Suddenly people in uniform and dark suits are no longer intimidating. Doing what your heart knows to be right is no longer intimidating and consequences for those actions take on the same nature of a brief experience that passes in the blink of an infinite eye. Intimidation is all in the mind. Beyond the mind there is no intimidation.

An open heart does not consider consequences for what it knows to be right. To do so would be to consider not doing what it knows to be right and for a heart in its power that is never an option. The Renegade Mind is really the Renegade Heart. Consideration of consequences will always provide a getaway car for the mind and

the heart doesn't want one. What is right in the light of what we face today is to stop cooperating with Wetiko in all its forms and to do it without fear or compromise. You cannot compromise with tyranny when tyranny always demands more until it has everything. Life is your perception and you are your destiny. Change your perception and you change your life. Change collective perception and we change the world.

*Come on people ... One human family, One heart, One goal ...*  
**FREEEEEEEDOM!**

We must settle for nothing less.

## Postscript

The big scare story as the book goes to press is the 'Indian' variant and the world is being deluged with propaganda about the 'Covid catastrophe' in India which mirrors in its lies and misrepresentations what happened in Italy before the first lockdown in 2020.

The *New York Post* published a picture of someone who had 'collapsed in the street from Covid' in India in April, 2021, which was actually taken during a gas leak in May, 2020. Same old, same old. Media articles in mid-February were asking why India had been so untouched by 'Covid' and then as their vaccine rollout gathered pace the alleged 'cases' began to rapidly increase. Indian 'Covid vaccine' maker Bharat Biotech was funded into existence by the Bill and Melinda Gates Foundation (the pair announced their divorce in May, 2021, which is a pity because they so deserve each other). The Indian 'Covid crisis' was ramped up by the media to terrify the world and prepare people for submission to still more restrictions. The scam that worked the first time was being repeated only with far more people seeing through the deceit. [Davidicke.com](http://Davidicke.com) and [Ickonic.com](http://Ickonic.com) have sought to tell the true story of what is happening by talking to people living through the Indian nightmare which has nothing to do with 'Covid'. We posted a letter from 'Alisha' in Pune who told a very different story to government and media mendacity. She said scenes of dying people and overwhelmed hospitals were designed to hide what was really happening – genocide and starvation. Alisha said that millions had already died of starvation during the ongoing lockdowns while government and media were lying and making it look like the 'virus':

Restaurants, shops, gyms, theatres, basically everything is shut. The cities are ghost towns. Even so-called 'essential' businesses are only open till 11am in the morning. You basically have just an hour to buy food and then your time is up.

Inter-state travel and even inter-district travel is banned. The cops wait at all major crossroads to question why you are traveling outdoors or to fine you if you are not wearing a mask.

The medical community here is also complicit in genocide, lying about hospitals being full and turning away people with genuine illnesses, who need immediate care. They have even created a shortage of oxygen cylinders.

This is the classic Cult modus operandi played out in every country. Alisha said that people who would not have a PCR test not testing for the 'virus' were being denied hospital treatment. She said the people hit hardest were migrant workers and those in rural areas. Most businesses employed migrant workers and with everything closed there were no jobs, no income and no food. As a result millions were dying of starvation or malnutrition. All this was happening under Prime Minister Narendra Modi, a 100-percent asset of the Cult, and it emphasises yet again the scale of pure anti-human evil we are dealing with. Australia banned its people from returning home from India with penalties for trying to do so of up to five years in jail and a fine of £37,000. The manufactured 'Covid' crisis in India was being prepared to justify further fascism in the West. Obvious connections could be seen between the Indian 'vaccine' programme and increased 'cases' and this became a common theme. The Seychelles, the most per capita 'Covid vaccinated' population in the world, went back into lockdown after a 'surge of cases'.

Long ago the truly evil Monsanto agricultural biotechnology corporation with its big connections to Bill Gates devastated Indian farming with genetically-modified crops. Human rights activist Gurcharan Singh highlighted the efforts by the Indian government to complete the job by destroying the food supply to hundreds of millions with 'Covid' lockdowns. He said that 415 million people at the bottom of the disgusting caste system (still going whatever they say) were below the poverty line and struggled to feed themselves every year. Now the government was imposing lockdown at just the

time to destroy the harvest. This deliberate policy was leading to mass starvation. People may reel back at the suggestion that a government would do that, but Wetiko-controlled 'leaders' are capable of any level of evil. In fact what is described in India is in the process of being instigated worldwide. The food chain and food supply are being targeted at every level to cause world hunger and thus control. Bill Gates is not the biggest owner of farmland in America for no reason and destroying access to food aids both the depopulation agenda and the plan for synthetic 'food' already being funded into existence by Gates. Add to this the coming hyper-inflation from the suicidal creation of fake 'money' in response to 'Covid' and the breakdown of container shipping systems and you have a cocktail that can only lead one way and is meant to. The Cult plan is to crash the entire system to 'build back better' with the Great Reset.

### **'Vaccine' transmission**

Reports from all over the world continue to emerge of women suffering menstrual and fertility problems after having the fake 'vaccine' and of the non-'vaccinated' having similar problems when interacting with the 'vaccinated'. There are far too many for 'coincidence' to be credible. We've had menopausal women getting periods, others having periods stop or not stopping for weeks, passing clots, sometimes the lining of the uterus, breast irregularities, and miscarriages (which increased by 400 percent in parts of the United States). Non-'vaccinated' men and children have suffered blood clots and nose bleeding after interaction with the 'vaccinated'. Babies have died from the effects of breast milk from a 'vaccinated' mother. Awake doctors – the small minority – speculated on the cause of non-'vaccinated' suffering the same effects as the 'vaccinated'. Was it nanotechnology in the synthetic substance transmitting frequencies or was it a straight chemical bioweapon that was being transmitted between people? I am not saying that some kind of chemical transmission is not one possible answer, but the foundation of all that the Cult does is frequency and



this is fertile ground for understanding how transmission can happen. American doctor Carrie Madej, an internal medicine physician and osteopath, has been practicing for the last 20 years, teaching medical students, and she says attending different meetings where the agenda for humanity was discussed. Madej, who operates out of Georgia, did not dismiss other possible forms of transmission, but she focused on frequency in search of an explanation for transmission. She said the Moderna and Pfizer 'vaccines' contained nano-lipid particles as a key component. This was a brand new technology never before used on humanity. 'They're using a nanotechnology which is pretty much little tiny computer bits ... nanobots or hydrogel.' Inside the 'vaccines' was 'this sci-fi kind of substance' which suppressed immune checkpoints to get into the cell. I referred to this earlier as the 'Trojan horse' technique that tricks the cell into opening a gateway for the self-replicating synthetic material and while the immune system is artificially suppressed the body has no defences. Madej said the substance served many purposes including an on-demand ability to 'deliver the payload' and using the nano 'computer bits' as biosensors in the body. 'It actually has the ability to accumulate data from your body, like your breathing, your respiration, thoughts, emotions, all kinds of things.'

She said the technology obviously has the ability to operate through Wi-Fi and transmit and receive energy, messages, frequencies or impulses. 'Just imagine you're getting this new substance in you and it can react to things all around you, the 5G, your smart device, your phones.' We had something completely foreign in the human body that had never been launched large scale at a time when we were seeing 5G going into schools and hospitals (plus the Musk satellites) and she believed the 'vaccine' transmission had something to do with this: '... if these people have this inside of them ... it can act like an antenna and actually transmit it outwardly as well.' The synthetic substance produced its own voltage and so it could have that kind of effect. This fits with my own contention that the nano receiver-transmitters are designed to connect people to the

Smart Grid and break the receiver-transmitter connection to expanded consciousness. That would explain the French energy healer's experience of the disconnection of body from 'soul' with those who have had the 'vaccine'. The nanobots, self-replicating inside the body, would also transmit the synthetic frequency which could be picked up through close interaction by those who have not been 'vaccinated'. Madej speculated that perhaps it was 5G and increased levels of other radiation that was causing the symptoms directly although interestingly she said that non-'vaccinated' patients had shown improvement when they were away from the 'vaccinated' person they had interacted with. It must be remembered that you can control frequency and energy with your mind and you can consciously create energetic barriers or bubbles with the mind to stop damaging frequencies from penetrating your field. American paediatrician Dr Larry Palevsky said the 'vaccine' was not a 'vaccine' and was never designed to protect from a 'viral' infection. He called it 'a massive, brilliant propaganda of genocide' because they didn't have to inject everyone to get the result they wanted. He said the content of the jabs was able to infuse any material into the brain, heart, lungs, kidneys, liver, sperm and female productive system. 'This is genocide; this is a weapon of mass destruction.' At the same time American colleges were banning students from attending if they didn't have this life-changing and potentially life-ending 'vaccine'. Class action lawsuits must follow when the consequences of this college fascism come to light. As the book was going to press came reports about fertility effects on sperm in 'vaccinated' men which would absolutely fit with what I have been saying and hospitals continued to fill with 'vaccine' reactions. Another question is what about transmission via blood transfusions? The NHS has extended blood donation restrictions from seven days after a 'Covid vaccination' to 28 days after even a sore arm reaction.

I said in the spring of 2020 that the then touted 'Covid vaccine' would be ongoing each year like the flu jab. A year later Pfizer CEO, the appalling Albert Bourla, said people would 'likely' need a 'booster dose' of the 'vaccine' within 12 months of getting 'fully

vaccinated' and then a yearly shot. 'Variants will play a key role', he said confirming the point. Johnson & Johnson CEO Alex Gorsky also took time out from his 'vaccine' disaster to say that people may need to be vaccinated against 'Covid-19' each year. UK Health Secretary, the psychopath Matt Hancock, said additional 'boosters' would be available in the autumn of 2021. This is the trap of the 'vaccine passport'. The public will have to accept every last 'vaccine' they introduce, including for the fake 'variants', or it would cease to be valid. The only other way in some cases would be continuous testing with a test not testing for the 'virus' and what is on the swabs constantly pushed up your nose towards the brain every time?

### **'Vaccines' changing behaviour**

I mentioned in the body of the book how I believed we would see gathering behaviour changes in the 'vaccinated' and I am already hearing such comments from the non-'vaccinated' describing behaviour changes in friends, loved ones and work colleagues. This will only increase as the self-replicating synthetic material and nanoparticles expand in body and brain. An article in the *Guardian* in 2016 detailed research at the University of Virginia in Charlottesville which developed a new method for controlling brain circuits associated with complex animal behaviour. The method, dubbed 'magnetogenetics', involves genetically-engineering a protein called ferritin, which stores and releases iron, to create a magnetised substance – 'Magneto' – that can activate specific groups of nerve cells from a distance. This is claimed to be an advance on other methods of brain activity manipulation known as optogenetics and chemogenetics (the Cult has been developing methods of brain control for a long time). The ferritin technique is said to be non-invasive and able to activate neurons 'rapidly and reversibly'. In other words, human thought and perception. The article said that earlier studies revealed how nerve cell proteins 'activated by heat and mechanical pressure can be genetically engineered so that they become sensitive to radio waves and magnetic fields, by attaching them to an iron-storing protein called ferritin, or to inorganic

paramagnetic particles'. Sensitive to radio waves and magnetic fields? You mean like 5G, 6G and 7G? This is the human-AI Smart Grid hive mind we are talking about. The *Guardian* article said:

... the researchers injected Magneto into the striatum of freely behaving mice, a deep brain structure containing dopamine-producing neurons that are involved in reward and motivation, and then placed the animals into an apparatus split into magnetised and non-magnetised sections.

Mice expressing Magneto spent far more time in the magnetised areas than mice that did not, because activation of the protein caused the striatal neurons expressing it to release dopamine, so that the mice found being in those areas rewarding. This shows that Magneto can remotely control the firing of neurons deep within the brain, and also control complex behaviours.

Make no mistake this basic methodology will be part of the 'Covid vaccine' cocktail and using magnetics to change brain function through electromagnetic field frequency activation. The Pentagon is developing a 'Covid vaccine' using ferritin. Magnetics would explain changes in behaviour and why videos are appearing across the Internet as I write showing how magnets stick to the skin at the point of the 'vaccine' shot. Once people take these 'vaccines' anything becomes possible in terms of brain function and illness which will be blamed on 'Covid-19' and 'variants'. Magnetic field manipulation would further explain why the non-'vaccinated' are reporting the same symptoms as the 'vaccinated' they interact with and why those symptoms are reported to decrease when not in their company. Interestingly 'Magneto', a 'mutant', is a character in the Marvel Comic *X-Men* stories with the ability to manipulate magnetic fields and he believes that mutants should fight back against their human oppressors by any means necessary. The character was born Erik Lehnsherr to a Jewish family in Germany.

## **Cult-controlled courts**

The European Court of Human Rights opened the door for mandatory 'Covid-19 vaccines' across the continent when it ruled in a Czech Republic dispute over childhood immunisation that legally

enforced vaccination could be 'necessary in a democratic society'. The 17 judges decided that compulsory vaccinations did not breach human rights law. On the face of it the judgement was so inverted you gasp for air. If not having a vaccine infused into your body is not a human right then what is? Ah, but they said human rights law which has been specifically written to delete all human rights at the behest of the state (the Cult). Article 8 of the European Convention on Human Rights relates to the right to a private life. The crucial word here is '*except*':

There shall be no interference by a public authority with the exercise of this right EXCEPT such as is in accordance with the law and is necessary in a democratic society in the interests of national security, public safety or the economic wellbeing of the country, for the prevention of disorder or crime, for the protection of health or morals, or for the protection of the rights and freedoms of others [My emphasis].

No interference *except* in accordance with the law means there *are* no 'human rights' *except* what EU governments decide you can have at their behest. 'As is necessary in a democratic society' explains that reference in the judgement and 'in the interests of national security, public safety or the economic well-being of the country, for the prevention of disorder or crime, for the protection of health or morals, or for the protection of the rights and freedoms of others' gives the EU a coach and horses to ride through 'human rights' and scatter them in all directions. The judiciary is not a check and balance on government extremism; it is a vehicle to enforce it. This judgement was almost laughably predictable when the last thing the Cult wanted was a decision that went against mandatory vaccination. Judges rule over and over again to benefit the system of which they are a part. Vaccination disputes that come before them are invariably delivered in favour of doctors and authorities representing the view of the state which owns the judiciary. Oh, yes, and we have even had calls to stop putting 'Covid-19' on death certificates within 28 days of a 'positive test' because it is claimed the practice makes the 'vaccine' appear not to work. They are laughing at you.

The scale of madness, inhumanity and things to come was highlighted when those not 'vaccinated' for 'Covid' were refused evacuation from the Caribbean island of St Vincent during massive volcanic eruptions. Cruise ships taking residents to the safety of another island allowed only the 'vaccinated' to board and the rest were left to their fate. Even in life and death situations like this we see 'Covid' stripping people of their most basic human instincts and the insanity is even more extreme when you think that fake 'vaccine'-makers are not even claiming their body-manipulating concoctions stop 'infection' and 'transmission' of a 'virus' that doesn't exist. St Vincent Prime Minister Ralph Gonsalves said: 'The chief medical officer will be identifying the persons already vaccinated so that we can get them on the ship.' Note again the power of the chief medical officer who, like Whitty in the UK, will be answering to the World Health Organization. This is the Cult network structure that has overridden politicians who 'follow the science' which means doing what WHO-controlled 'medical officers' and 'science advisers' tell them. Gonsalves even said that residents who were 'vaccinated' after the order so they could board the ships would still be refused entry due to possible side effects such as 'wooziness in the head'. The good news is that if they were woozy enough in the head they could qualify to be prime minister of St Vincent.

## **Microchipping freedom**

The European judgement will be used at some point to justify moves to enforce the 'Covid' DNA-manipulating procedure. Sandra Ro, CEO of the Global Blockchain Business Council, told a World Economic Forum event that she hoped 'vaccine passports' would help to 'drive forced consent and standardisation' of global digital identity schemes: 'I'm hoping with the desire and global demand for some sort of vaccine passport – so that people can get travelling and working again – [it] will drive forced consent, standardisation, and frankly, cooperation across the world.' The lady is either not very bright, or thoroughly mendacious, to use the term 'forced consent'.

You do not 'consent' if you are forced – you *submit*. She was describing what the plan has been all along and that's to enforce a digital identity on every human without which they could not function. 'Vaccine passports' are opening the door and are far from the end goal. A digital identity would allow you to be tracked in everything you do in cyberspace and this is the same technique used by Cult-owned China to enforce its social credit system of total control. The ultimate 'passport' is planned to be a microchip as my books have warned for nearly 30 years. Those nice people at the Pentagon working for the Cult-controlled Defense Advanced Research Projects Agency (DARPA) claimed in April, 2021, they have developed a microchip inserted under the skin to detect 'asymptomatic Covid-19 infection' before it becomes an outbreak and a 'revolutionary filter' that can remove the 'virus' from the blood when attached to a dialysis machine. The only problems with this are that the 'virus' does not exist and people transmitting the 'virus' with no symptoms is brain-numbing bullshit. This is, of course, not a ruse to get people to be microchipped for very different reasons. DARPA also said it was producing a one-stop 'vaccine' for the 'virus' and all 'variants'. One of the most sinister organisations on Planet Earth is doing this? Better have it then. These people are insane because Wetiko that possesses them is insane.

Researchers from the Salk Institute in California announced they have created an embryo that is part human and part monkey. My books going back to the 1990s have exposed experiments in top secret underground facilities in the United States where humans are being crossed with animal and non-human 'extraterrestrial' species. They are now easing that long-developed capability into the public arena and there is much more to come given we are dealing with psychiatric basket cases. Talking of which – Elon Musk's scientists at Neuralink trained a monkey to play Pong and other puzzles on a computer screen using a joystick and when the monkey made the correct move a metal tube squirted banana smoothie into his mouth which is the basic technique for training humans into unquestioning compliance. Two Neuralink chips were in the monkey's skull and

more than 2,000 wires 'fanned out' into its brain. Eventually the monkey played a video game purely with its brain waves. Psychopathic narcissist Musk said the 'breakthrough' was a step towards putting Neuralink chips into human skulls and merging minds with artificial intelligence. *Exactly*. This man is so dark and Cult to his DNA.

## **World Economic Fascism (WEF)**

The World Economic Forum is telling you the plan by the statements made at its many and various events. Cult-owned fascist YouTube CEO Susan Wojcicki spoke at the 2021 WEF Global Technology Governance Summit (see the name) in which 40 governments and 150 companies met to ensure 'the responsible design and deployment of emerging technologies'. Orwellian translation: 'Ensuring the design and deployment of long-planned technologies will advance the Cult agenda for control and censorship.' Freedom-destroyer and Nuremberg-bound Wojcicki expressed support for tech platforms like hers to censor content that is 'technically legal but could be harmful'. Who decides what is 'harmful'? She does and they do. 'Harmful' will be whatever the Cult doesn't want people to see and we have legislation proposed by the UK government that would censor content on the basis of 'harm' no matter if the information is fair, legal and provably true. Make that *especially* if it is fair, legal and provably true. Wojcicki called for a global coalition to be formed to enforce content moderation standards through automated censorship. This is a woman and mega-censor so self-deluded that she shamelessly accepted a 'free expression' award – *Wojcicki* – in an event sponsored by her own *YouTube*. They have no shame and no self-awareness.

You know that 'Covid' is a scam and Wojcicki a Cult operative when YouTube is censoring medical and scientific opinion purely on the grounds of whether it supports or opposes the Cult 'Covid' narrative. Florida governor Ron DeSantis compiled an expert panel with four professors of medicine from Harvard, Oxford, and Stanford Universities who spoke against forcing children and



vaccinated people to wear masks. They also said there was no proof that lockdowns reduced spread or death rates of 'Covid-19'. Cult-gofer Wojcicki and her YouTube deleted the panel video 'because it included content that contradicts the consensus of local and global health authorities regarding the efficacy of masks to prevent the spread of Covid-19'. This 'consensus' refers to what the Cult tells the World Health Organization to say and the WHO tells 'local health authorities' to do. Wojcicki knows this, of course. The panellists pointed out that censorship of scientific debate was responsible for deaths from many causes, but Wojcicki couldn't care less. She would not dare go against what she is told and as a disgrace to humanity she wouldn't want to anyway. The UK government is seeking to pass a fascist 'Online Safety Bill' to specifically target with massive fines and other means non-censored video and social media platforms to make them censor 'lawful but harmful' content like the Cult-owned Facebook, Twitter, Google and YouTube. What is 'lawful but harmful' would be decided by the fascist Blair-created Ofcom.

Another WEF obsession is a cyber-attack on the financial system and this is clearly what the Cult has planned to take down the bank accounts of everyone – except theirs. Those that think they have enough money for the Cult agenda not to matter to them have got a big lesson coming if they continue to ignore what is staring them in the face. The World Economic Forum, funded by Gates and fronted by Klaus Schwab, announced it would be running a 'simulation' with the Russian government and global banks of just such an attack called Cyber Polygon 2021. What they simulate – as with the 'Covid' Event 201 – they plan to instigate. The WEF is involved in a project with the Cult-owned Carnegie Endowment for International Peace called the WEF-Carnegie Cyber Policy Initiative which seeks to merge Wall Street banks, 'regulators' (I love it) and intelligence agencies to 'prevent' (arrange and allow) a cyber-attack that would bring down the global financial system as long planned by those that control the WEF and the Carnegie operation. The Carnegie Endowment for International Peace sent an instruction to First World

War US President Woodrow Wilson not to let the war end before society had been irreversibly transformed.

## **The Wuhan lab diversion**

As I close, the Cult-controlled authorities and lapdog media are systematically pushing 'the virus was released from the Wuhan lab' narrative. There are two versions – it happened by accident and it happened on purpose. Both are nonsense. The perceived existence of the never-shown-to-exist 'virus' is vital to sell the impression that there is actually an infective agent to deal with and to allow the endless potential for terrifying the population with 'variants' of a 'virus' that does not exist. The authorities at the time of writing are going with the 'by accident' while the alternative media is promoting the 'on purpose'. Cable news host Tucker Carlson who has questioned aspects of lockdown and 'vaccine' compulsion has bought the Wuhan lab story. 'Everyone now agrees' he said. Well, I don't and many others don't and the question is *why* does the system and its media suddenly 'agree'? When the media moves as one unit with a narrative it is always a lie – witness the hour by hour mendacity of the 'Covid' era. Why would this Cult-owned combination which has unleashed lies like machine gun fire suddenly 'agree' to tell the truth??

Much of the alternative media is buying the lie because it fits the conspiracy narrative, but it's the *wrong* conspiracy. The real conspiracy is that *there is no virus* and that is what the Cult is desperate to hide. The idea that the 'virus' was released by accident is ludicrous when the whole 'Covid' hoax was clearly long-planned and waiting to be played out as it was so fast in accordance with the Rockefeller document and Event 201. So they prepared everything in detail over decades and then sat around strumming their fingers waiting for an 'accidental' release from a bio-lab? *What??* It's crazy. Then there's the 'on purpose' claim. You want to circulate a 'deadly virus' and hide the fact that you've done so and you release it down the street from the highest-level bio-lab in China? I repeat – *What??*

You would release it far from that lab to stop any association being made. But, no, we'll do it in a place where the connection was certain to be made. Why would you need to scam 'cases' and 'deaths' and pay hospitals to diagnose 'Covid-19' if you had a real 'virus'? What are sections of the alternative media doing believing this crap? Where were all the mass deaths in Wuhan from a 'deadly pathogen' when the recovery to normal life after the initial propaganda was dramatic in speed? Why isn't the 'deadly pathogen' now circulating all over China with bodies in the street? Once again we have the technique of tell them what they want to hear and they will likely believe it. The alternative media has its 'conspiracy' and with Carlson it fits with his 'China is the danger' narrative over years. China *is* a danger as a global Cult operations centre, but not for this reason. The Wuhan lab story also has the potential to instigate conflict with China when at some stage the plan is to trigger a Problem-Reaction-Solution confrontation with the West. Question everything – *everything* – and especially when the media agrees on a common party line.

### **Third wave ... fourth wave ... fifth wave ...**

As the book went into production the world was being set up for more lockdowns and a 'third wave' supported by invented 'variants' that were increasing all the time and will continue to do so in public statements and computer programs, but not in reality. India became the new Italy in the 'Covid' propaganda campaign and we were told to be frightened of the new 'Indian strain'. Somehow I couldn't find it within myself to do so. A document produced for the UK government entitled 'Summary of further modelling of easing of restrictions – Roadmap Step 2' declared that a third wave was inevitable (of course when it's in the script) and it would be the fault of children and those who refuse the health-destroying fake 'Covid vaccine'. One of the computer models involved came from the Cult-owned *Imperial College* and the other from Warwick University which I wouldn't trust to tell me the date in a calendar factory. The document states that both models presumed extremely high uptake

of the 'Covid vaccines' and didn't allow for 'variants'. The document states: 'The resurgence is a result of some people (mostly children) being ineligible for vaccination; others choosing not to receive the vaccine; and others being vaccinated but not perfectly protected.' The mendacity takes the breath away. Okay, blame those with a brain who won't take the DNA-modifying shots and put more pressure on children to have it as 'trials' were underway involving children as young as six months with parents who give insanity a bad name. Massive pressure is being put on the young to have the fake 'vaccine' and child age consent limits have been systematically lowered around the world to stop parents intervening. Most extraordinary about the document was its claim that the 'third wave' would be driven by 'the resurgence in both hospitalisations and deaths ... dominated by *those that have received two doses of the vaccine*, comprising around 60-70% of the wave respectively'. The predicted peak of the 'third wave' suggested 300 deaths per day with 250 of them *fully 'vaccinated' people*. How many more lies do acquiescers need to be told before they see the obvious? Those who took the job to 'protect themselves' are projected to be those who mostly get sick and die? So what's in the 'vaccine'? The document went on:

It is possible that a summer of low prevalence could be followed by substantial increases in incidence over the following autumn and winter. Low prevalence in late summer should not be taken as an indication that SARS-CoV-2 has retreated or that the population has high enough levels of immunity to prevent another wave.

They are telling you the script and while many British people believed 'Covid' restrictions would end in the summer of 2021 the government was preparing for them to be ongoing. Authorities were awarding contracts for 'Covid marshals' to police the restrictions with contracts starting in July, 2021, and going through to January 31st, 2022, and the government was advertising for 'Media Buying Services' to secure media propaganda slots worth a potential £320 million for 'Covid-19 campaigns' with a contract not ending until March, 2022. The recipient – via a list of other front companies – was reported to be American media marketing giant Omnicom Group

Inc. While money is no object for 'Covid' the UK waiting list for all other treatment – including life-threatening conditions – passed 4.5 million. Meantime the Cult is seeking to control all official 'inquiries' to block revelations about what has really been happening and why. It must not be allowed to – we need Nuremberg jury trials in every country. The cover-up doesn't get more obvious than appointing ultra-Zionist professor Philip Zelikow to oversee two dozen US virologists, public health officials, clinicians, former government officials and four American 'charitable foundations' to 'learn the lessons' of the 'Covid' debacle. The personnel will be those that created and perpetuated the 'Covid' lies while Zelikow is the former executive director of the 9/11 Commission who ensured that the truth about those attacks never came out and produced a report that must be among the most mendacious and manipulative documents ever written – see *The Trigger* for the detailed exposure of the almost unimaginable 9/11 story in which Sabbatians can be found at every level.

## **Passive no more**

People are increasingly challenging the authorities with amazing numbers of people taking to the streets in London well beyond the ability of the Face-Nappies to stop them. Instead the Nappies choose situations away from the mass crowds to target, intimidate, and seek to promote the impression of 'violent protestors'. One such incident happened in London's Hyde Park. Hundreds of thousands walking through the streets in protest against 'Covid' fascism were ignored by the Cult-owned BBC and most of the rest of the mainstream media, but they delighted in reporting how police were injured in 'clashes with protestors'. The truth was that a group of people gathered in Hyde Park at the end of one march when most had gone home and they were peacefully having a good time with music and chat. Face-Nappies who couldn't deal with the full-march crowd then waded in with their batons and got more than they bargained for. Instead of just standing for this criminal brutality the crowd used their numerical superiority to push the Face-Nappies out of the

park. Eventually the Nappies turned and ran. Unfortunately two or three idiots in the crowd threw drink cans striking two officers which gave the media and the government the image they wanted to discredit the 99.9999 percent who were peaceful. The idiots walked straight into the trap and we must always be aware of potential agent provocateurs used by the authorities to discredit their targets.

This response from the crowd – the can people apart – must be a turning point when the public no longer stand by while the innocent are arrested and brutally attacked by the Face-Nappies. That doesn't mean to be violent, that's the last thing we need. We'll leave the violence to the Face-Nappies and government. But it does mean that when the Face-Nappies use violence against peaceful people the numerical superiority is employed to stop them and make citizen's arrests or Common Law arrests for a breach of the peace. The time for being passive in the face of fascism is over.

We are the many, they are the few, and we need to make that count before there is no freedom left and our children and grandchildren face an ongoing fascist nightmare.

*COME ON PEOPLE – IT'S TIME.*

### **One final thought ...**

The power of love  
A force from above  
Cleaning my soul  
Flame on burn desire  
Love with tongues of fire  
Purge the soul  
Make love your goal

I'll protect you from the hooded claw  
Keep the vampires from your door  
When the chips are down I'll be around  
With my undying, death-defying  
Love for you

Envy will hurt itself  
Let yourself be beautiful  
Sparkling love, flowers  
And pearls and pretty girls  
Love is like an energy  
Rushin' rushin' inside of me

This time we go sublime  
Lovers entwine, divine, divine,  
Love is danger, love is pleasure  
Love is pure – the only treasure

I'm so in love with you  
Purge the soul  
Make love your goal

The power of love  
A force from above  
Cleaning my soul  
The power of love  
A force from above  
A sky-scraping dove

Flame on burn desire  
Love with tongues of fire  
Purge the soul  
Make love your goal

**Frankie Goes To Hollywood**



## APPENDIX

### **Cowan-Kaufman-Morell Statement on Virus Isolation (SOVI)**

*Isolation: The action of isolating; the fact or condition of being isolated or standing alone; separation from other things or persons; solitariness*

Oxford English Dictionary

The controversy over whether the SARS-CoV-2 virus has ever been isolated or purified continues. However, using the above definition, common sense, the laws of logic and the dictates of science, any unbiased person must come to the conclusion that the SARS-CoV-2 virus has never been isolated or purified. As a result, no confirmation of the virus' existence can be found. The logical, common sense, and scientific consequences of this fact are:

- the structure and composition of something not shown to exist can't be known, including the presence, structure, and function of any hypothetical spike or other proteins;
- the genetic sequence of something that has never been found can't be known;
- "variants" of something that hasn't been shown to exist can't be known;
- it's impossible to demonstrate that SARS-CoV-2 causes a disease called Covid-19.

In as concise terms as possible, here's the proper way to isolate, characterize and demonstrate a new virus. First, one takes samples (blood, sputum, secretions) from many people (e.g. 500) with symptoms which are unique and specific enough to characterize an illness. Without mixing these samples with ANY tissue or products that also contain genetic material, the virologist macerates, filters and ultracentrifuges i.e. *purifies* the specimen. This common virology technique, done for decades to isolate bacteriophages<sup>1</sup> and so-called giant viruses in every virology lab, then allows the virologist to demonstrate with electron microscopy thousands of identically sized and shaped particles. These particles are the isolated and purified virus.

These identical particles are then checked for uniformity by physical and/or microscopic techniques. Once the purity is determined, the particles may be further characterized. This would include examining the structure, morphology, and chemical composition of the particles. Next, their genetic makeup is characterized by extracting the genetic material directly from the purified particles and using genetic-sequencing techniques, such as Sanger sequencing, that have also been around for decades. Then one does an analysis to confirm that these uniform particles are exogenous (outside) in origin as a virus is conceptualized to be, and not the normal breakdown products of dead and dying tissues.<sup>2</sup> (As of May 2020, we know that virologists have no way to determine whether the particles they're seeing are viruses or just normal breakdown products of dead and dying tissues.)<sup>3</sup>

---

1 Isolation, characterization and analysis of bacteriophages from the haloalkaline lake Elmenteita, Kenya Julia Khayeli Akhwale et al, PLOS One, Published: April 25, 2019.  
<https://journals.plos.org/plosone/article?id=10.1371/journal.pone.0215734> – accessed 2/15/21

---

2 "Extracellular Vesicles Derived From Apoptotic Cells: An Essential Link Between Death and Regeneration," Maojiao Li et al, Frontiers in Cell and Developmental Biology, 2020 October 2.  
<https://www.frontiersin.org/articles/10.3389/fcell.2020.573511/full> – accessed 2/15/21

If we have come this far then we have fully isolated, characterized, and genetically sequenced an exogenous virus particle. However, we still have to show it is causally related to a disease. This is carried out by exposing a group of healthy subjects (animals are usually used) to this isolated, purified virus in the manner in which the disease is thought to be transmitted. If the animals get sick with the same disease, as confirmed by clinical and autopsy findings, one has now shown that the virus actually causes a disease. This demonstrates infectivity and transmission of an infectious agent.

None of these steps has even been attempted with the SARS-CoV-2 virus, nor have all these steps been successfully performed for any so-called pathogenic virus. Our research indicates that a single study showing these steps does not exist in the medical literature.

Instead, since 1954, virologists have taken unpurified samples from a relatively few people, often less than ten, with a similar disease. They then minimally process this sample and inoculate this unpurified sample onto tissue culture containing usually four to six other types of material – all of which contain identical genetic material as to what is called a “virus.” The tissue culture is starved and poisoned and naturally disintegrates into many types of particles, some of which contain genetic material. Against all common sense, logic, use of the English language and scientific integrity, this process is called “virus isolation.” This brew containing fragments of genetic material from many sources is then subjected to genetic analysis, which then creates in a computer-simulation process the alleged sequence of the alleged virus, a so called in silico genome. At no time is an actual virus confirmed by electron microscopy. At no time is a genome extracted and sequenced from an actual virus. This is scientific fraud.

The observation that the unpurified specimen — inoculated onto tissue culture along with toxic antibiotics, bovine fetal tissue, amniotic fluid and other tissues — destroys the kidney tissue onto which it is inoculated is given as evidence of the virus' existence and pathogenicity. This is scientific fraud.

From now on, when anyone gives you a paper that suggests the SARS-CoV-2 virus has been isolated, please check the methods sections. If the researchers used Vero cells or any other culture method, you know that their process was not isolation. You will hear the following excuses for why actual isolation isn't done:

1. There were not enough virus particles found in samples from patients to analyze.
2. Viruses are intracellular parasites; they can't be found outside the cell in this manner.

If No. 1 is correct, and we can't find the virus in the sputum of sick people, then on what evidence do we think the virus is dangerous or even lethal? If No. 2 is correct, then how is the virus spread from person to person? We are told it emerges from the cell to infect others. Then why isn't it possible to find it?

Finally, questioning these virology techniques and conclusions is not some distraction or divisive issue. Shining the light on this truth is essential to stop this terrible fraud that humanity is confronting. For, as we now know, if the virus has never been isolated, sequenced or shown to cause illness, if the virus is imaginary, then why are we wearing masks, social distancing and putting the whole world into prison?

Finally, if pathogenic viruses don't exist, then what is going into those injectable devices erroneously called "vaccines," and what is their purpose? This scientific question is the most urgent and relevant one of our time.

We are correct. The SARS-CoV2 virus does not exist.

Sally Fallon Morell, MA

Dr. Thomas Cowan, MD

Dr. Andrew Kaufman, MD

# Bibliography

- Alinsky, Saul:** *Rules for Radicals* (Vintage, 1989)
- Antelman, Rabbi Marvin:** *To Eliminate the Opiate* (Zahavia, 1974)
- Bastardi, Joe:** *The Climate Chronicles* (Relentless Thunder Press, 2018)
- Cowan, Tom:** *Human Heart, Cosmic Heart* (Chelsea Green Publishing, 2016)
- Cowan, Tom, and Fallon Morell, Sally:** *The Contagion Myth* (Skyhorse Publishing, 2020)
- Forbes, Jack D:** *Columbus And Other Cannibals – The Wetiko Disease of Exploitation, Imperialism, and Terrorism* (Seven Stories Press, 2008 – originally published in 1979)
- Gates, Bill:** *How to Avoid a Climate Disaster: The Solutions We Have and the Breakthroughs We Need* (Allen Lane, 2021)
- Huxley, Aldous:** *Brave New World* (Chatto & Windus, 1932)
- Köhnlein, Dr Claus, and Engelbrecht, Torsten:** *Virus Mania* (emu-Verlag, Lahnstein, 2020)
- Lanza, Robert, and Berman, Bob:** *Biocentrism* (BenBella Books, 2010)
- Lash, John Lamb:** *Not In His Image* (Chelsea Green Publishing, 2006)
- Lester, Dawn, and Parker, David:** *What Really Makes You Ill – Why everything you thought you knew about disease is wrong* (Independently Published, 2019)
- Levy, Paul:** *Dispelling Wetiko, Breaking the Spell of Evil* (North Atlantic Books, 2013)
- Marx, Karl:** *A World Without Jews* (Philosophical Library, first edition, 1959)
- Mullis, Kary:** *Dancing Naked in the Mine Field* (Bloomsbury, 1999)
- O'Brien, Cathy:** *Trance-Formation of America* (Reality Marketing, 1995)
- Scholem, Gershon:** *The Messianic Idea in Judaism* (Schocken Books, 1994)
- Schwab, Klaus, and Davis, Nicholas:** *Shaping the Future of the Fourth Industrial Revolution: A guide to building a better world* (Penguin Books, 2018)
- Schwab, Klaus:** *The Great Reset* (Agentur Schweiz, 2020)
- Sunstein, Cass and Thaler, Richard:** *Nudge: Improving Decisions About Health, Wealth, and Happiness* (Penguin, 2009)
- Swan, Shanna:** *Count Down: How Our Modern World Is Threatening Sperm Counts, Altering Male and Female Reproductive Development and Imperiling the Future of the Human Race* (Scribner, 2021)
- Tegmark, Max:** *Our Mathematical Universe: My Quest for the Ultimate Nature of Reality* (Penguin, 2015)
- Velikovsky, Immanuel:** *Worlds in Collision* (Paradigma, 2009)

**Wilton, Robert:** *The Last Days of the Romanovs* (Blurb, 2018, first published 1920)

# Index

## A

### **abusive relationships**

blaming themselves, abused as [ref1](#)

children [ref1](#), [ref2](#), [ref3](#), [ref4](#), [ref5](#), [ref6](#), [ref7](#), [ref8](#), [ref9](#), [ref10](#)

conspiracy theories [ref1](#)

domestic abuse [ref1](#), [ref2](#)

economic abuse and dependency [ref1](#)

isolation [ref1](#)

physical abuse [ref1](#)

psychological abuse [ref1](#)

signs of abuse [ref1](#)

### **addiction**

alcoholism [ref1](#)

frequencies [ref1](#)

substance abuse [ref1](#), [ref2](#)

technology [ref1](#), [ref2](#), [ref3](#)

**Adelson, Sheldon** [ref1](#), [ref2](#), [ref3](#)

**Agenda 21/Agenda 2030 (UN)** [ref1](#), [ref2](#), [ref3](#), [ref4](#)

**AIDs/HIV** [ref1](#)

causal link between HIV and AIDs [ref1](#), [ref2](#)

retroviruses [ref1](#)

testing [ref1](#), [ref2](#)

trial-run for Covid-19, as [ref1](#), [ref2](#)

**aliens/extraterrestrials** [ref1](#), [ref2](#)

**aluminium** [ref1](#)

**Amazon** [ref1](#), [ref2](#), [ref3](#)



**amplification cycles** [ref1](#), [ref2](#)  
**anaphylactic shock** [ref1](#), [ref2](#), [ref3](#), [ref4](#)  
**animals** [ref1](#), [ref2](#), [ref3](#)  
**antibodies** [ref1](#), [ref2](#), [ref3](#), [ref4](#), [ref5](#)  
**Antifa** [ref1](#), [ref2](#), [ref3](#), [ref4](#)  
**antigens** [ref1](#), [ref2](#)  
**anti-Semitism** [ref1](#), [ref2](#), [ref3](#)  
**Archons** [ref1](#), [ref2](#)  
    consciousness [ref1](#), [ref2](#), [ref3](#)  
    energy [ref1](#), [ref2](#), [ref3](#)  
    ennoia [ref1](#)  
    genetic manipulation [ref1](#), [ref2](#)  
    inversion [ref1](#), [ref2](#), [ref3](#)  
    lockdowns [ref1](#)  
    money [ref1](#)  
    radiation [ref1](#)  
    religion [ref1](#), [ref2](#)  
    technology [ref1](#), [ref2](#), [ref3](#)  
    Wetiko factor [ref1](#), [ref2](#), [ref3](#), [ref4](#)  
**artificial intelligence (AI)** [ref1](#)  
**army made up of robots** [ref1](#), [ref2](#)  
    Human 2.0 [ref1](#), [ref2](#)  
    Internet [ref1](#)  
    MHRA [ref1](#)  
    Morgellons fibres [ref1](#), [ref2](#)  
    Smart Grid [ref1](#)  
    Wetiko factor [ref1](#)  
**asymptomatic, Covid-19 as** [ref1](#), [ref2](#), [ref3](#)  
**aviation industry** [ref1](#)

## **B**

**banking, finance and money** [ref1](#), [ref2](#), [ref3](#)

2008 crisis [ref1](#), [ref2](#)

boom and bust [ref1](#)

cashless digital money systems [ref1](#)

central banks [ref1](#)

credit [ref1](#)

digital currency [ref1](#)

fractional reserve lending [ref1](#)

Great Reset [ref1](#)

guaranteed income [ref1](#), [ref2](#), [ref3](#)

Human 2.0 [ref1](#)

incomes, destruction of [ref1](#), [ref2](#)

interest [ref1](#)

one per cent [ref1](#), [ref2](#)

scams [ref1](#)

**BBC** [ref1](#), [ref2](#), [ref3](#), [ref4](#), [ref5](#), [ref6](#), [ref7](#), [ref8](#)

**Becker-Phelps, Leslie** [ref1](#)

**Behavioural Insights Team (BIT) (Nudge Unit)** [ref1](#), [ref2](#), [ref3](#)

**behavioural scientists *and* psychologists, advice from** [ref1](#), [ref2](#)

**Bezos, Jeff** [ref1](#), [ref2](#), [ref3](#), [ref4](#)

**Biden, Hunter** [ref1](#)

**Biden, Joe** [ref1](#), [ref2](#), [ref3](#), [ref4](#), [ref5](#), [ref6](#), [ref7](#), [ref8](#), [ref9](#), [ref10](#), [ref11](#),  
[ref12](#), [ref13](#), [ref14](#), [ref15](#), [ref16](#), [ref17](#)

**Big Pharma**

cholesterol [ref1](#)

health professionals [ref1](#), [ref2](#)

immunity from prosecution in US [ref1](#)

vaccines [ref1](#), [ref2](#), [ref3](#), [ref4](#), [ref5](#), [ref6](#), [ref7](#), [ref8](#)

Wetiko factor [ref1](#), [ref2](#)

WHO [ref1](#), [ref2](#), [ref3](#)

**Bill and Melinda Gates Foundation** [ref1](#), [ref2](#), [ref3](#), [ref4](#), [ref5](#), [ref6](#),  
[ref7](#)

**billionaires** [ref1](#), [ref2](#), [ref3](#), [ref4](#), [ref5](#), [ref6](#), [ref7](#), [ref8](#), [ref9](#) [ref10](#), [ref11](#)

**bird flu (H5N1)** [ref1](#)

**Black Lives Matter (BLM)** [ref1](#), [ref2](#), [ref3](#), [ref4](#), [ref5](#)

**Blair, Tony** [ref1](#), [ref2](#), [ref3](#), [ref4](#), [ref5](#), [ref6](#), [ref7](#)

**Brin, Sergei** [ref1](#), [ref2](#), [ref3](#), [ref4](#), [ref5](#), [ref6](#), [ref7](#)

**British Empire** [ref1](#)

**Bush, George HW** [ref1](#), [ref2](#)

**Bush, George W** [ref1](#), [ref2](#), [ref3](#), [ref4](#)

**Byrd, Robert** [ref1](#)

## **C**

### **Canada**

Global Cult [ref1](#)

hate speech [ref1](#)

internment [ref1](#)

masks [ref1](#)

old people [ref1](#)

SARS-COV-2 [ref1](#)

satellites [ref1](#)

vaccines [ref1](#)

wearable technology [ref1](#)

**Capitol Hill riot** [ref1](#), [ref2](#)

agents provocateur [ref1](#)

Antifa [ref1](#)

Black Lives Matter (BLM) [ref1](#), [ref2](#)

QAnon [ref1](#)

security precautions, lack of [ref1](#), [ref2](#), [ref3](#)

**carbon dioxide** [ref1](#), [ref2](#)

**care homes, deaths in** [ref1](#), [ref2](#)

**cashless digital money systems** [ref1](#)

**censorship** [ref1](#), [ref2](#), [ref3](#), [ref4](#), [ref5](#)

fact-checkers [ref1](#)

masks [ref1](#)

media [ref1](#), [ref2](#)

private messages [ref1](#)

social media [ref1](#), [ref2](#), [ref3](#), [ref4](#), [ref5](#), [ref6](#)

transgender persons [ref1](#)

vaccines [ref1](#), [ref2](#), [ref3](#)

Wokeness [ref1](#)

**Centers for Disease Control (CDC) (United States)** [ref1](#), [ref2](#), [ref3](#),  
[ref4](#), [ref5](#), [ref6](#), [ref7](#), [ref8](#), [ref9](#), [ref10](#), [ref11](#), [ref12](#), [ref13](#)

**centralisation** [ref1](#), [ref2](#), [ref3](#), [ref4](#), [ref5](#), [ref6](#), [ref7](#), [ref8](#)

**chakras** [ref1](#)

**change agents** [ref1](#), [ref2](#), [ref3](#)

**chemtrails** [ref1](#), [ref2](#), [ref3](#)

**chief medical officers and scientific advisers** [ref1](#), [ref2](#), [ref3](#), [ref4](#),  
[ref5](#), [ref6](#)

**children** *see also* **young people**

abuse [ref1](#), [ref2](#), [ref3](#), [ref4](#), [ref5](#), [ref6](#), [ref7](#), [ref8](#), [ref9](#), [ref10](#)

care, taken into [ref1](#), [ref2](#), [ref3](#)

education [ref1](#), [ref2](#), [ref3](#), [ref4](#)

energy [ref1](#)

family courts [ref1](#)

hand sanitisers [ref1](#)

human sacrifice [ref1](#)

lockdowns [ref1](#), [ref2](#), [ref3](#)

masks [ref1](#), [ref2](#), [ref3](#), [ref4](#), [ref5](#)

mental health [ref1](#)

old people [ref1](#)

parents, replacement of [ref1](#), [ref2](#)

Psyop (psychological operation), Covid as a [ref1](#), [ref2](#)

reframing [ref1](#)

smartphone addiction [ref1](#)

social distancing and isolation [ref1](#)  
social media [ref1](#)  
transgender persons [ref1](#), [ref2](#)  
United States [ref1](#)  
vaccines [ref1](#), [ref2](#), [ref3](#), [ref4](#), [ref5](#), [ref6](#), [ref7](#), [ref8](#), [ref9](#), [ref10](#)  
Wetiko factor [ref1](#)

## **China** [ref1](#), [ref2](#), [ref3](#), [ref4](#)

anal swab tests [ref1](#)  
**Chinese Revolution** [ref1](#), [ref2](#), [ref3](#)  
digital currency [ref1](#)  
Global Cult [ref1](#), [ref2](#), [ref3](#), [ref4](#), [ref5](#), [ref6](#), [ref7](#), [ref8](#), [ref9](#)  
guaranteed income [ref1](#)  
Imperial College [ref1](#)  
Israel [ref1](#)  
lockdown [ref1](#), [ref2](#)  
masculinity crisis [ref1](#)  
masks [ref1](#)  
media [ref1](#)  
origins of virus in China [ref1](#), [ref2](#), [ref3](#), [ref4](#), [ref5](#)  
pollution causing respiratory diseases [ref1](#)  
Sabbatians [ref1](#), [ref2](#)  
Smart Grid [ref1](#), [ref2](#)  
social credit system [ref1](#)  
testing [ref1](#), [ref2](#)  
United States [ref1](#), [ref2](#)  
vaccines [ref1](#), [ref2](#)  
Wetiko factor [ref1](#)  
wet market conspiracy [ref1](#)  
Wuhan [ref1](#), [ref2](#), [ref3](#), [ref4](#), [ref5](#), [ref6](#), [ref7](#)

## **cholesterol** [ref1](#), [ref2](#)

## **Christianity** [ref1](#), [ref2](#), [ref3](#), [ref4](#), [ref5](#)

criticism [ref1](#)  
cross, inversion of the [ref1](#)

Nag Hammadi texts [ref1](#), [ref2](#), [ref3](#)

Roman Catholic Church [ref1](#), [ref2](#)

Sabbatians [ref1](#), [ref2](#)

Satan [ref1](#), [ref2](#), [ref3](#), [ref4](#)

Wokeness [ref1](#)

**class** [ref1](#), [ref2](#)

**climate change hoax** [ref1](#), [ref2](#), [ref3](#), [ref4](#), [ref5](#)

Agenda 21/Agenda 2030 [ref1](#), [ref2](#), [ref3](#)

carbon dioxide [ref1](#), [ref2](#)

Club of Rome [ref1](#), [ref2](#), [ref3](#), [ref4](#), [ref5](#)

fear [ref1](#)

funding [ref1](#)

Global Cult [ref1](#)

green new deals [ref1](#)

green parties [ref1](#)

inversion [ref1](#)

perception, control of [ref1](#)

PICC [ref1](#)

reframing [ref1](#)

temperature, increases in [ref1](#)

United Nations [ref1](#), [ref2](#)

Wikipedia [ref1](#)

Wokeness [ref1](#), [ref2](#)

**Clinton, Bill** [ref1](#), [ref2](#), [ref3](#), [ref4](#), [ref5](#), [ref6](#)

**Clinton, Hillary** [ref1](#), [ref2](#), [ref3](#)

**the cloud** [ref1](#), [ref2](#), [ref3](#), [ref4](#), [ref5](#), [ref6](#), [ref7](#)

**Club of Rome and climate change hoax** [ref1](#), [ref2](#), [ref3](#), [ref4](#), [ref5](#)

**cognitive therapy** [ref1](#)

**Cohn, Roy** [ref1](#)

**Common Law** [ref1](#)

Admiralty Law [ref1](#)

arrests [ref1](#), [ref2](#)

contractual law, Statute Law as [ref1](#)

corporate entities, people as [ref1](#)

legalese [ref1](#)

sea, law of the [ref1](#)

Statute Law [ref1](#)

**Common Purpose leadership programme** [ref1](#), [ref2](#)

**communism** [ref1](#), [ref2](#)

**co-morbidities** [ref1](#)

**computer-generated virus,**

**Covid-19** as [ref1](#), [ref2](#), [ref3](#)

**computer models** [ref1](#), [ref2](#), [ref3](#), [ref4](#), [ref5](#)

**connections** [ref1](#), [ref2](#), [ref3](#), [ref4](#)

**consciousness** [ref1](#), [ref2](#), [ref3](#), [ref4](#)

Archons [ref1](#), [ref2](#), [ref3](#)

expanded [ref1](#), [ref2](#), [ref3](#), [ref4](#), [ref5](#), [ref6](#), [ref7](#)

experience [ref1](#)

heart [ref1](#)

infinity [ref1](#), [ref2](#)

religion [ref1](#), [ref2](#)

self-identity [ref1](#)

simulation thesis [ref1](#)

vaccines [ref1](#)

Wetiko factor [ref1](#), [ref2](#)

**conspiracy theorists** [ref1](#), [ref2](#), [ref3](#), [ref4](#), [ref5](#)

**contradictory rules** [ref1](#)

**contrails** [ref1](#)

**Corman-Drosten test** [ref1](#), [ref2](#), [ref3](#), [ref4](#)

**countermimicry** [ref1](#), [ref2](#), [ref3](#)

**Covid-19 vaccines** *see* vaccines

**Covidiots** [ref1](#), [ref2](#)

**Cowan, Tom** [ref1](#), [ref2](#), [ref3](#), [ref4](#)

**crimes against humanity** [ref1](#), [ref2](#), [ref3](#), [ref4](#), [ref5](#), [ref6](#), [ref7](#), [ref8](#)

cyber-operations [ref1](#)

cyberwarfare [ref1](#)

## **D**

DARPA (Defense Advanced Research Projects Agency) [ref1](#)

deaths

care homes [ref1](#)

certificates [ref1](#), [ref2](#), [ref3](#), [ref4](#)

mortality rate [ref1](#)

post-mortems/autopsies [ref1](#)

recording [ref1](#), [ref2](#), [ref3](#), [ref4](#), [ref5](#), [ref6](#), [ref7](#)

vaccines [ref1](#), [ref2](#), [ref3](#), [ref4](#), [ref5](#)

deceit

pyramid of deceit [ref1](#), [ref2](#)

sequence of deceit [ref1](#)

decoding [ref1](#), [ref2](#), [ref3](#)

dehumanisation [ref1](#), [ref2](#), [ref3](#)

Delphi technique [ref1](#)

democracy [ref1](#)

dependency [ref1](#), [ref2](#), [ref3](#), [ref4](#), [ref5](#)

Descartes, René [ref1](#)

DNA

numbers [ref1](#)

vaccines [ref1](#), [ref2](#), [ref3](#), [ref4](#), [ref5](#), [ref6](#), [ref7](#), [ref8](#), [ref9](#), [ref10](#)

DNR (do not resuscitate)

orders [ref1](#)

domestic abuse [ref1](#), [ref2](#)

downgrading of Covid-19 [ref1](#)

Drosten, Christian [ref1](#), [ref2](#), [ref3](#), [ref4](#), [ref5](#), [ref6](#), [ref7](#)

Duesberg, Peter [ref1](#), [ref2](#)



## **E**

**economic abuse** [ref1](#)

**Edmunds, John** [ref1](#), [ref2](#)

**education** [ref1](#), [ref2](#), [ref3](#), [ref4](#)

**electromagnetic spectrum** [ref1](#), [ref2](#)

**Enders, John** [ref1](#)

**energy**

Archons [ref1](#), [ref2](#), [ref3](#)

children and young people [ref1](#)

consciousness [ref1](#)

decoding [ref1](#)

frequencies [ref1](#), [ref2](#), [ref3](#), [ref4](#)

heart [ref1](#)

human energy field [ref1](#)

source, humans as an energy [ref1](#), [ref2](#)

vaccines [ref1](#)

viruses [ref1](#)

**ennoia** [ref1](#)

**Epstein, Jeffrey** [ref1](#), [ref2](#)

**eternal 'I'** [ref1](#), [ref2](#)

**ethylene oxide** [ref1](#)

**European Union** [ref1](#), [ref2](#), [ref3](#), [ref4](#)

**Event** [ref1](#) *and* **Bill Gates** [ref2](#)

**exosomes, Covid-19 as natural defence mechanism called** [ref1](#)

**experience** [ref1](#), [ref2](#)

**Extinction Rebellion** [ref1](#), [ref2](#)

## **F**

**Facebook**

addiction [ref1](#), 448–50

Facebook

Archons [ref1](#)

ensorship [ref1](#), [ref2](#), [ref3](#)

hate speech [ref1](#)

monopoly, as [ref1](#)

private messages, censorship of [ref1](#)

Sabbatians [ref1](#)

United States election fraud [ref1](#)

vaccines [ref1](#)

Wetiko factor [ref1](#)

**fact-checkers** [ref1](#)

**Fauci, Anthony** [ref1](#), [ref2](#), [ref3](#), [ref4](#), [ref5](#), [ref6](#), [ref7](#), [ref8](#), [ref9](#), [ref10](#),  
[ref11](#), [ref12](#)

**fear** [ref1](#), [ref2](#), [ref3](#), [ref4](#)

climate change [ref1](#)

computer models [ref1](#)

conspiracy theories [ref1](#)

empty hospitals [ref1](#)

Italy [ref1](#), [ref2](#), [ref3](#)

lockdowns [ref1](#), [ref2](#), [ref3](#), [ref4](#)

masks [ref1](#), [ref2](#)

media [ref1](#), [ref2](#)

medical staff [ref1](#)

Psyop (psychological operation), Covid as a [ref1](#)

Wetiko factor [ref1](#), [ref2](#)

**female infertility** [ref1](#)

**Fermi Paradox** [ref1](#)

**Ferguson, Neil** [ref1](#), [ref2](#), [ref3](#), [ref4](#), [ref5](#), [ref6](#), [ref7](#)

**fertility, decline in** [ref1](#)

**The Field** [ref1](#), [ref2](#), [ref3](#), [ref4](#), [ref5](#), [ref6](#), [ref7](#), [ref8](#)

**finance** *see* **banking, finance and money**

**five-senses** [ref1](#), [ref2](#)

Archons [ref1](#), [ref2](#), [ref3](#)

censorship [ref1](#)  
    consciousness, expansion of [ref1](#), [ref2](#), [ref3](#), [ref4](#), [ref5](#), [ref6](#)  
    decoding [ref1](#)  
    education [ref1](#), [ref2](#)  
    the Field [ref1](#), [ref2](#)  
    God, personification of [ref1](#)  
    infinity [ref1](#), [ref2](#)  
    media [ref1](#)  
    paranormal [ref1](#)  
    perceptual programming [ref1](#), [ref2](#)  
    Phantom Self [ref1](#)  
    pneuma not nous, using [ref1](#)  
    reincarnation [ref1](#)  
    self-identity [ref1](#)  
    Wetiko factor [ref1](#), [ref2](#), [ref3](#), [ref4](#), [ref5](#), [ref6](#)  
**5G** [ref1](#), [ref2](#), [ref3](#), [ref4](#), [ref5](#), [ref6](#), [ref7](#), [ref8](#)  
**Floyd, George and protests, killing of** [ref1](#)  
**flu, re-labelling of** [ref1](#), [ref2](#), [ref3](#)  
**food and water, control of** [ref1](#), [ref2](#)  
**Freemasons** [ref1](#), [ref2](#), [ref3](#), [ref4](#), [ref5](#), [ref6](#)  
**Frei, Rosemary** [ref1](#)  
**frequencies**  
    addictions [ref1](#)  
    Archons [ref1](#), [ref2](#), [ref3](#)  
    awareness [ref1](#)  
    chanting and mantras [ref1](#)  
    consciousness [ref1](#)  
    decoding [ref1](#), [ref2](#)  
    education [ref1](#)  
    electromagnetic (EMF) frequencies [ref1](#)  
    energy [ref1](#), [ref2](#), [ref3](#), [ref4](#)  
    fear [ref1](#)

the Field [ref1](#), [ref2](#) 5G [ref3](#), [ref4](#), [ref5](#), [ref6](#), [ref7](#), [ref8](#), [ref9](#), [ref10](#)  
five-senses [ref1](#), [ref2](#)  
ghosts [ref1](#)  
Gnostics [ref1](#)  
hive-minds [ref1](#)  
human, meaning of [ref1](#)  
light [ref1](#), [ref2](#)  
love [ref1](#), [ref2](#)  
magnetism [ref1](#)  
perception [ref1](#)  
reality [ref1](#), [ref2](#), [ref3](#)  
simulation [ref1](#)  
terror [ref1](#)  
vaccines [ref1](#)  
Wetiko [ref1](#), [ref2](#), [ref3](#)

**Fuellmich, Reiner** [ref1](#), [ref2](#), [ref3](#)

**furlough/rescue payments** [ref1](#)

## **G**

**Gallo, Robert** [ref1](#), [ref2](#), [ref3](#)

**Gates, Bill**

Archons [ref1](#), [ref2](#), [ref3](#)  
climate change [ref1](#), [ref2](#), [ref3](#), [ref4](#)  
Daily Pass tracking system [ref1](#)  
Epstein [ref1](#)  
fascism [ref1](#)  
five senses [ref1](#)  
GAVI [ref1](#)  
Great Reset [ref1](#)  
GSK [ref1](#)  
Imperial College [ref1](#), [ref2](#)  
Johns Hopkins University [ref1](#), [ref2](#), [ref3](#)

lockdowns [ref1](#), [ref2](#)

masks [ref1](#)

Nuremberg trial, proposal for [ref1](#), [ref2](#)

Rockefellers [ref1](#), [ref2](#)

social distancing and isolation [ref1](#)

Sun, dimming the [ref1](#)

synthetic meat [ref1](#), [ref2](#)

vaccines [ref1](#), [ref2](#), [ref3](#), [ref4](#), [ref5](#), [ref6](#), [ref7](#)

Wellcome Trust [ref1](#)

Wetiko factor [ref1](#), [ref2](#), [ref3](#)

WHO [ref1](#), [ref2](#), [ref3](#), [ref4](#), [ref5](#), [ref6](#), [ref7](#), [ref8](#), [ref9](#), [ref10](#)

Wokeness [ref1](#)

World Economic Forum [ref1](#), [ref2](#), [ref3](#), [ref4](#)

**Gates, Melinda** [ref1](#), [ref2](#), [ref3](#)

**GAVI vaccine alliance** [ref1](#)

**genetics, manipulation of** [ref1](#), [ref2](#), [ref3](#)

**Germany** [ref1](#), [ref2](#), [ref3](#), [ref4](#), [ref5](#), [ref6](#) *see also* **Nazi Germany**

**Global Cult** [ref1](#), [ref2](#), [ref3](#), [ref4](#), [ref5](#)

anti-human, why Global Cult is [ref1](#)

Black Lives Matter (BLM) [ref1](#), [ref2](#), [ref3](#), [ref4](#)

China [ref1](#), [ref2](#), [ref3](#), [ref4](#), [ref5](#), [ref6](#), [ref7](#), [ref8](#), [ref9](#)

climate change hoax [ref1](#)

contradictory rules [ref1](#)

Covid-19 [ref1](#), [ref2](#), [ref3](#)

fascism [ref1](#)

geographical origins [ref1](#)

immigration [ref1](#)

Internet [ref1](#)

mainstream media [ref1](#), [ref2](#)

masks [ref1](#), [ref2](#)

monarchy [ref1](#)

non-human dimension [ref1](#)

perception [ref1](#)  
political parties [ref1](#), [ref2](#)  
pyramidal hierarchy [ref1](#), [ref2](#), [ref3](#)  
reframing [ref1](#)  
Sabbantian-Frankism [ref1](#), [ref2](#)  
science, manipulation of [ref1](#)  
spider and the web [ref1](#)  
transgender persons [ref1](#)  
vaccines [ref1](#)  
who controls the Cult [ref1](#)  
Wokeness [ref1](#), [ref2](#), [ref3](#), [ref4](#)

**globalisation** [ref1](#), [ref2](#)

**Gnostics** [ref1](#), [ref2](#), [ref3](#), [ref4](#), [ref5](#)

**Google** [ref1](#), [ref2](#), [ref3](#), [ref4](#)

**government**

behavioural scientists and psychologists, advice from [ref1](#), [ref2](#)  
definition [ref1](#)

Joint Biosecurity Centre (JBC) [ref1](#)

people, abusive relationship with [ref1](#)

**Great Reset** [ref1](#), [ref2](#), [ref3](#), [ref4](#), [ref5](#), [ref6](#)

fascism [ref1](#), [ref2](#), [ref3](#)

financial system [ref1](#)

Human 2.0 [ref1](#)

water and food, control of [ref1](#)

**green parties** [ref1](#)

**Griesz-Brisson, Margarite** [ref1](#)

**guaranteed income** [ref1](#), [ref2](#), [ref3](#)

**H**

**Hancock, Matt** [ref1](#), [ref2](#), [ref3](#), [ref4](#), [ref5](#)

**hand sanitisers** [ref1](#)

**heart** [ref1](#), [ref2](#)

**hive-minds/groupthink** [ref1](#), [ref2](#), [ref3](#)

**holographs** [ref1](#), [ref2](#), [ref3](#), [ref4](#)

**hospitals, empty** [ref1](#)

**human, meaning of** [ref1](#)

**Human 2.0** [ref1](#)

addiction to technology [ref1](#)

artificial intelligence (AI) [ref1](#), [ref2](#)

elimination of Human 1.0 [ref1](#)

fertility, decline in [ref1](#)

Great Reset [ref1](#)

implantables [ref1](#)

money [ref1](#)

mRNA [ref1](#)

nanotechnology [ref1](#)

parents, replacement of [ref1](#), [ref2](#)

Smart Grid, connection to [ref1](#), [ref2](#)

synthetic biology [ref1](#), [ref2](#), [ref3](#), [ref4](#)

testosterone levels, decrease in [ref1](#)

transgender = transhumanism [ref1](#), [ref2](#), [ref3](#)

vaccines [ref1](#), [ref2](#), [ref3](#), [ref4](#)

**human sacrifice** [ref1](#), [ref2](#), [ref3](#)

**Hunger Games Society** [ref1](#), [ref2](#), [ref3](#), [ref4](#), [ref5](#), [ref6](#), [ref7](#)

**Huxley, Aldous** [ref1](#), [ref2](#), [ref3](#)

**I**

**identity politics** [ref1](#), [ref2](#), [ref3](#)

**Illuminati** [ref1](#), [ref2](#)

**illusory physical reality** [ref1](#)

**immigration** [ref1](#), [ref2](#), [ref3](#), [ref4](#)

**Imperial College** [ref1](#), [ref2](#), [ref3](#), [ref4](#), [ref5](#), [ref6](#)

**implantables** [ref1](#), [ref2](#)

**incomes, destruction of** [ref1](#), [ref2](#)

**Infinite Awareness** [ref1](#), [ref2](#), [ref3](#), [ref4](#)

**Internet** [ref1](#), [ref2](#) *see also* social media

artificial intelligence (AI) [ref1](#)

independent journalism, lack of [ref1](#)

Internet of Bodies (IoB) [ref1](#)

**Internet of Everything (IoE)** [ref1](#), [ref2](#)

**Internet of Things (IoT)** [ref1](#), [ref2](#)

**lockdowns** [ref1](#)

Psyop (psychological operation), Covid as a [ref1](#)  
trolls [ref1](#)

**intersectionality** [ref1](#)

**inversion**

Archons [ref1](#), [ref2](#), [ref3](#)

climate change hoax [ref1](#)

energy [ref1](#)

Judaism [ref1](#), [ref2](#), [ref3](#)

symbolism [ref1](#)

Wetiko factor [ref1](#)

Wokeness [ref1](#), [ref2](#), [ref3](#)

**Islam**

Archons [ref1](#)

crypto-Jews [ref1](#)

Islamic State [ref1](#), [ref2](#)

Jinn and Djinn [ref1](#), [ref2](#), [ref3](#)

Ottoman Empire [ref1](#)

Wahhabism [ref1](#)

**isolation** *see* **social distancing** *and* **isolation**

**Israel**

China [ref1](#)

Cyber Intelligence Unit Beersheba complex [ref1](#)

expansion of illegal settlements [ref1](#)



formation [ref1](#)  
Global Cult [ref1](#)  
Judaism [ref1](#), [ref2](#), [ref3](#), [ref4](#), [ref5](#)  
medical experiments, consent for [ref1](#)  
Mossad [ref1](#), [ref2](#), [ref3](#), [ref4](#)  
Palestine-Israel conflict [ref1](#), [ref2](#), [ref3](#)  
parents, replacement of [ref1](#)  
Sabbatians [ref1](#), [ref2](#), [ref3](#), [ref4](#), [ref5](#)  
September 11, 2001, terrorist attacks on United States [ref1](#)  
Silicon Valley [ref1](#)  
Smart Grid [ref1](#), [ref2](#)  
United States [ref1](#), [ref2](#)  
vaccines [ref1](#)  
Wetiko factor [ref1](#)

## **Italy**

fear [ref1](#), [ref2](#), [ref3](#)  
Lombardy [ref1](#), [ref2](#), [ref3](#)  
vaccines [ref1](#)

## **J**

**Johns Hopkins University** [ref1](#), [ref2](#), [ref3](#), [ref4](#), [ref5](#), [ref6](#), [ref7](#)  
**Johnson, Boris** [ref1](#), [ref2](#), [ref3](#), [ref4](#), [ref5](#), [ref6](#), [ref7](#), [ref8](#)  
**Joint Biosecurity Centre (JBC)** [ref1](#)

## **Judaism**

anti-Semitism [ref1](#), [ref2](#), [ref3](#)  
Archons [ref1](#), [ref2](#)  
crypto-Jews [ref1](#)  
inversion [ref1](#), [ref2](#), [ref3](#)  
Israel [ref1](#), [ref2](#), [ref3](#), [ref4](#), [ref5](#)  
Labour Party [ref1](#)  
Nazi Germany [ref1](#), [ref2](#), [ref3](#), [ref4](#)  
Sabbatians [ref1](#), [ref2](#), [ref3](#), [ref4](#), [ref5](#)

Silicon Valley [ref1](#)  
Torah [ref1](#)  
United States [ref1](#), [ref2](#)  
Zionists [ref1](#), [ref2](#), [ref3](#)

## **K**

Kaufman, Andrew [ref1](#), [ref2](#), [ref3](#), [ref4](#)  
knowledge [ref1](#), [ref2](#), [ref3](#), [ref4](#), [ref5](#), [ref6](#)  
Koch's postulates [ref1](#)  
Kurzweil, Ray [ref1](#), [ref2](#), [ref3](#), [ref4](#), [ref5](#), [ref6](#), [ref7](#)  
Kushner, Jared [ref1](#), [ref2](#)

## **L**

Labour Party [ref1](#), [ref2](#)  
Lanka, Stefan [ref1](#), [ref2](#)  
Lateral Flow Device (LFD) [ref1](#)  
Levy, Paul [ref1](#), [ref2](#), [ref3](#)  
Life Program [ref1](#)  
lockdowns [ref1](#), [ref2](#), [ref3](#)  
    amplification tampering [ref1](#)  
    Archons [ref1](#)  
    Behavioural Insights Team [ref1](#)  
    Black Lives Matter (BLM) [ref1](#)  
    care homes, deaths in [ref1](#)  
    children  
abuse [ref1](#), [ref2](#)  
mental health [ref1](#)  
    China [ref1](#), [ref2](#)  
    computer models [ref1](#)  
    consequences [ref1](#), [ref2](#)  
    dependency [ref1](#), [ref2](#), [ref3](#)

domestic abuse [ref1](#)  
fall in cases [ref1](#)  
fear [ref1](#), [ref2](#), [ref3](#), [ref4](#)  
guaranteed income [ref1](#)  
Hunger Games Society [ref1](#), [ref2](#), [ref3](#)  
interaction, destroying [ref1](#)  
Internet [ref1](#), [ref2](#)  
overdoses [ref1](#)  
perception [ref1](#)  
police-military state [ref1](#), [ref2](#)  
protests [ref1](#), [ref2](#), [ref3](#), [ref4](#), [ref5](#)  
psychopathic personality [ref1](#), [ref2](#), [ref3](#)  
reporting/snitching, encouragement of [ref1](#), [ref2](#)  
testing [ref1](#)  
vaccines [ref1](#)  
Wetiko factor [ref1](#)  
WHO [ref1](#)  
**love** [ref1](#), [ref2](#), [ref3](#)  
**Lucifer** [ref1](#), [ref2](#), [ref3](#)

## **M**

**Madej, Carrie** [ref1](#), [ref2](#)  
**Magufuli, John** [ref1](#), [ref2](#)  
**mainstream media** [ref1](#)  
BBC [ref1](#), [ref2](#), [ref3](#), [ref4](#), [ref5](#), [ref6](#), [ref7](#), [ref8](#)  
censorship [ref1](#), [ref2](#)  
China [ref1](#)  
climate change hoax [ref1](#)  
fear [ref1](#), [ref2](#)  
Global Cult [ref1](#), [ref2](#)  
independent journalism, lack of [ref1](#)  
Ofcom [ref1](#), [ref2](#), [ref3](#)

perception [ref1](#), [ref2](#)

Psyop (psychological operation), Covid as a [ref1](#)

Sabbatians [ref1](#), [ref2](#)

social disapproval [ref1](#)

social distancing and isolation [ref1](#)

United States [ref1](#), [ref2](#)

vaccines [ref1](#), [ref2](#), [ref3](#), [ref4](#), [ref5](#)

**Mao Zedong** [ref1](#), [ref2](#), [ref3](#)

**Marx and Marxism** [ref1](#), [ref2](#), [ref3](#), [ref4](#), [ref5](#), [ref6](#)

**masculinity** [ref1](#)

**masks/face coverings** [ref1](#), [ref2](#), [ref3](#)

    censorship [ref1](#)

    children [ref1](#), [ref2](#), [ref3](#), [ref4](#), [ref5](#)

    China, made in [ref1](#)

    dehumanisation [ref1](#), [ref2](#), [ref3](#)

    fear [ref1](#), [ref2](#)

    flu [ref1](#)

    health professionals [ref1](#), [ref2](#), [ref3](#), [ref4](#)

    isolation [ref1](#)

    laughter [ref1](#)

**mass non-cooperation** [ref1](#)

**microplastics, risk of** [ref1](#)

**mind control** [ref1](#)

**multiple masks** [ref1](#)

oxygen deficiency [ref1](#), [ref2](#), [ref3](#)

police [ref1](#), [ref2](#), [ref3](#), [ref4](#), [ref5](#)

pollution, as cause of plastic [ref1](#)

Psyop (psychological operation), Covid as a [ref1](#)

reframing [ref1](#), [ref2](#)

risk assessments, lack of [ref1](#), [ref2](#)

self-respect [ref1](#)

surgeons [ref1](#)

United States [ref1](#)  
vaccines [ref1](#), [ref2](#), [ref3](#), [ref4](#), [ref5](#)  
Wetiko factor [ref1](#)  
'worms' [ref1](#)  
*The Matrix* movies [ref1](#), [ref2](#), [ref3](#)  
measles [ref1](#), [ref2](#)  
media see mainstream media  
Medicines and Healthcare products Regulatory Agency (MHRA)  
[ref1](#), [ref2](#), [ref3](#), [ref4](#)  
**Mesopotamia** [ref1](#)  
**messaging** [ref1](#)  
**military-police state** [ref1](#), [ref2](#), [ref3](#)  
**mind control** [ref1](#), [ref2](#), [ref3](#), [ref4](#), [ref5](#), [ref6](#) *see also* MKUltra  
MKUltra [ref1](#), [ref2](#), [ref3](#)  
**monarchy** [ref1](#)  
**money** *see* **banking, finance and money**  
**Montagnier, Luc** [ref1](#), [ref2](#), [ref3](#)  
**Mooney, Bel** [ref1](#)  
**Morgellons disease** [ref1](#), [ref2](#)  
**mortality rate** [ref1](#)  
**Mullis, Kary** [ref1](#), [ref2](#), [ref3](#)  
**Musk, Elon** [ref1](#)

## **N**

**Nag Hammadi texts** [ref1](#), [ref2](#), [ref3](#)  
**nanotechnology** [ref1](#), [ref2](#), [ref3](#)  
**narcissism** [ref1](#)  
**Nazi Germany** [ref1](#), [ref2](#), [ref3](#), [ref4](#), [ref5](#), [ref6](#), [ref7](#), [ref8](#)  
**near-death experiences** [ref1](#), [ref2](#)  
**Neocons** [ref1](#), [ref2](#), [ref3](#)

**Neuro-Linguistic Programming (NLP) and the Delphi technique**  
[ref1](#)

**NHS (National Health Service)**

amplification cycles [ref1](#)

Common Purpose [ref1](#), [ref2](#)

mind control [ref1](#)

**NHS England** [ref1](#)

saving the NHS [ref1](#), [ref2](#)

vaccines [ref1](#), [ref2](#), [ref3](#), [ref4](#), [ref5](#)

whistle-blowers [ref1](#), [ref2](#), [ref3](#)

**No-Problem-Reaction-Solution** [ref1](#), [ref2](#), [ref3](#), [ref4](#)

**non-human dimension of Global Cult** [ref1](#)

**nous** [ref1](#)

**numbers, reality as** [ref1](#)

**Nuremberg Codes** [ref1](#), [ref2](#), [ref3](#)

**Nuremberg-like tribunal, proposal for** [ref1](#), [ref2](#), [ref3](#), [ref4](#), [ref5](#),  
[ref6](#), [ref7](#), [ref8](#), [ref9](#), [ref10](#), [ref11](#), [ref12](#)

## **O**

**Obama, Barack** [ref1](#), [ref2](#), [ref3](#), [ref4](#), [ref5](#), [ref6](#), [ref7](#), [ref8](#), [ref9](#), [ref10](#)

**O'Brien, Cathy** [ref1](#), [ref2](#), [ref3](#), [ref4](#)

**Ochel, Evita** [ref1](#)

**Ofcom** [ref1](#), [ref2](#), [ref3](#)

**old people** [ref1](#), [ref2](#), [ref3](#), [ref4](#), [ref5](#)

**Oneness** [ref1](#), [ref2](#), [ref3](#)

**Open Society Foundations (Soros)** [ref1](#), [ref2](#), [ref3](#)

**oxygen** 406, 528–34

## **P**

**paedophilia** [ref1](#), [ref2](#)

**Page, Larry** [ref1](#), [ref2](#), [ref3](#), [ref4](#), [ref5](#), [ref6](#), [ref7](#)

**Palestine-Israel conflict** [ref1](#), [ref2](#), [ref3](#)

**pandemic, definition of** [ref1](#)

**pandemic and health crisis scenarios/simulations** [ref1](#), [ref2](#), [ref3](#),  
[ref4](#)

**paranormal** [ref1](#)

**PCR tests** [ref1](#), [ref2](#), [ref3](#), [ref4](#), [ref5](#), [ref6](#), [ref7](#), [ref8](#)

**Pearl Harbor attacks, prior knowledge of** [ref1](#)

**Pelosi, Nancy** [ref1](#), [ref2](#), [ref3](#)

**perception** [ref1](#), [ref2](#), [ref3](#), [ref4](#)

climate change hoax [ref1](#)

control [ref1](#), [ref2](#), [ref3](#)

decoding [ref1](#), [ref2](#)

enslavement [ref1](#)

externally-delivered perceptions [ref1](#)

five senses [ref1](#)

human labels [ref1](#)

media [ref1](#), [ref2](#)

political parties [ref1](#), [ref2](#)

Psyop (psychological operation), Covid as a [ref1](#)

sale of perception [ref1](#)

self-identity [ref1](#), [ref2](#)

Wokeness [ref1](#)

**Phantom Self** [ref1](#), [ref2](#), [ref3](#)

**pharmaceutical industry** *see* **Big Pharma**

**phthalates** [ref1](#)

**Plato's Allegory of the Cave** [ref1](#), [ref2](#)

**pneuma** [ref1](#)

**police**

Black Lives Matter (BLM) [ref1](#)

brutality [ref1](#)

citizen's arrests [ref1](#), [ref2](#)

common law arrests [ref1](#), [ref2](#)

Common Purpose [ref1](#)  
defunding [ref1](#)  
lockdowns [ref1](#), [ref2](#)  
masks [ref1](#), [ref2](#), [ref3](#), [ref4](#)  
police-military state [ref1](#), [ref2](#), [ref3](#)  
psychopathic personality [ref1](#), [ref2](#), [ref3](#), [ref4](#)  
reframing [ref1](#)  
United States [ref1](#), [ref2](#), [ref3](#), [ref4](#)  
Wokeness [ref1](#)

**polio** [ref1](#)

**political correctness** [ref1](#), [ref2](#), [ref3](#), [ref4](#)

**political parties** [ref1](#), [ref2](#), [ref3](#), [ref4](#)

**political puppets** [ref1](#)

**pollution** [ref1](#), [ref2](#), [ref3](#)

**post-mortems/autopsies** [ref1](#)

**Postage Stamp Consensus** [ref1](#), [ref2](#)

**pre-emptive programming** [ref1](#)

**Problem-Reaction-Solution** [ref1](#), [ref2](#), [ref3](#), [ref4](#), [ref5](#), [ref6](#), [ref7](#), [ref8](#)

**Project for the New American Century** [ref1](#), [ref2](#), [ref3](#), [ref4](#)

**psychopathic personality** [ref1](#)

Archons [ref1](#)

heart energy [ref1](#)

lockdowns [ref1](#), [ref2](#), [ref3](#)

police [ref1](#), [ref2](#), [ref3](#), [ref4](#)

recruitment [ref1](#), [ref2](#)

vaccines [ref1](#)

wealth [ref1](#)

Wetiko [ref1](#), [ref2](#)

**Psyop (psychological operation), Covid as a** [ref1](#), [ref2](#), [ref3](#), [ref4](#),  
[ref5](#)

**Pushbackers** [ref1](#), [ref2](#), [ref3](#), [ref4](#)

**pyramid structure** [ref1](#), [ref2](#), [ref3](#), [ref4](#)



## Q

**QAnon Psyop** [ref1](#), [ref2](#), [ref3](#)

## R

**racism** *see also* **Black Lives**

Matter (BLM)

anti-racism industry [ref1](#)

class [ref1](#)

critical race theory [ref1](#)

culture [ref1](#)

intersectionality [ref1](#)

reverse racism [ref1](#)

white privilege [ref1](#), [ref2](#)

white supremacy [ref1](#), [ref2](#), [ref3](#), [ref4](#), [ref5](#)

Wokeness [ref1](#), [ref2](#), [ref3](#)

**radiation** [ref1](#), [ref2](#)

**randomness, illusion of** [ref1](#), [ref2](#), [ref3](#)

**reality** [ref1](#), [ref2](#), [ref3](#)

**reframing** [ref1](#), [ref2](#)

change agents [ref1](#), [ref2](#)

children [ref1](#)

climate change [ref1](#)

Common Purpose leadership programme [ref1](#), [ref2](#)

contradictory rules [ref1](#)

enforcers [ref1](#)

masks [ref1](#), [ref2](#)

NLP and the Delphi technique [ref1](#)

police [ref1](#)

Wetiko factor [ref1](#)

Wokeness [ref1](#), [ref2](#)

**religion** *see also* particular religions

alien invasions [ref1](#)

Archons [ref1](#), [ref2](#)  
consciousness [ref1](#), [ref2](#)  
control, system of [ref1](#), [ref2](#), [ref3](#)  
criticism, prohibition on [ref1](#)  
five senses [ref1](#)  
good and evil, war between [ref1](#)  
hidden non-human forces [ref1](#), [ref2](#)  
Sabbatians [ref1](#)  
save me syndrome [ref1](#)  
Wetiko [ref1](#)  
Wokeness [ref1](#)

**repetition and mind control** [ref1](#), [ref2](#), [ref3](#)  
**reporting/snitching, encouragement of** [ref1](#), [ref2](#)  
**Reptilians/Grey entities** [ref1](#)  
**rewiring the mind** [ref1](#)  
**Rivers, Thomas Milton** [ref1](#), [ref2](#)  
**Rockefeller family** [ref1](#), [ref2](#), [ref3](#), [ref4](#), [ref5](#), [ref6](#), [ref7](#), [ref8](#), [ref9](#)  
**Rockefeller Foundation documents** [ref1](#), [ref2](#), [ref3](#), [ref4](#)  
**Roman Empire** [ref1](#)  
**Rothschild family** [ref1](#), [ref2](#), [ref3](#), [ref4](#), [ref5](#), [ref6](#), [ref7](#), [ref8](#), [ref9](#)  
**RT-PCR tests** [ref1](#), [ref2](#), [ref3](#), [ref4](#), [ref5](#), [ref6](#), [ref7](#), [ref8](#)  
**Russia**  
    collusion inquiry in US [ref1](#)  
**Russian Revolution** [ref1](#), [ref2](#)  
Sabbatians [ref1](#)

## **S**

**Sabbatian-Frankism** [ref1](#), [ref2](#)  
    anti-Semitism [ref1](#), [ref2](#)  
    banking and finance [ref1](#), [ref2](#), [ref3](#)  
    China [ref1](#), [ref2](#)  
    Israel [ref1](#), [ref2](#), [ref3](#), [ref4](#), [ref5](#)

Judaism [ref1](#), [ref2](#), [ref3](#), [ref4](#), [ref5](#)  
Lucifer [ref1](#)  
media [ref1](#), [ref2](#)  
Nazis [ref1](#), [ref2](#)  
QAnon [ref1](#)  
Rothschilds [ref1](#), [ref2](#), [ref3](#), [ref4](#), [ref5](#), [ref6](#)  
Russia [ref1](#)  
Saudi Arabia [ref1](#)  
Silicon Valley [ref1](#)  
Sumer [ref1](#)  
United States [ref1](#), [ref2](#), [ref3](#)  
Wetiko factor [ref1](#)  
Wokeness [ref1](#), [ref2](#), [ref3](#)  
**SAGE (Scientific Advisory Group for Emergencies)** [ref1](#), [ref2](#), [ref3](#),  
[ref4](#)  
**SARS-1** [ref1](#)  
**SARs-CoV-2** [ref1](#), [ref2](#), [ref3](#), [ref4](#), [ref5](#), [ref6](#), [ref7](#), [ref8](#)  
**Satan/Satanism** [ref1](#), [ref2](#), [ref3](#), [ref4](#), [ref5](#), [ref6](#), [ref7](#)  
**satellites in low-orbit** [ref1](#)  
**Saudi Arabia** [ref1](#)  
**Save Me Syndrome** [ref1](#)  
**scapegoating** [ref1](#)  
**Schwab, Klaus** [ref1](#), [ref2](#), [ref3](#), [ref4](#), [ref5](#), [ref6](#), [ref7](#), [ref8](#), [ref9](#), [ref10](#),  
[ref11](#), [ref12](#)  
**science, manipulation of** [ref1](#)  
**self-identity** [ref1](#), [ref2](#), [ref3](#), [ref4](#)  
**self-respect, attacks on** [ref1](#)  
**September 11, 2001, terrorist attacks on United States** [ref1](#), [ref2](#),  
[ref3](#), [ref4](#)  
**77th Brigade of UK military** [ref1](#), [ref2](#), [ref3](#)  
**Silicon Valley/tech giants** [ref1](#), [ref2](#), [ref3](#), [ref4](#), [ref5](#), [ref6](#) *see also*  
**Facebook**

Israel [ref1](#)

Sabbatians [ref1](#)

technocracy [ref1](#)

Wetiko factor [ref1](#)

Wokeness [ref1](#)

**simulation hypothesis** [ref1](#), [ref2](#), [ref3](#), [ref4](#), [ref5](#)

**Smart Grid** [ref1](#), [ref2](#), [ref3](#)

artificial intelligence (AI) [ref1](#)

China [ref1](#), [ref2](#)

control centres [ref1](#)

the Field [ref1](#)

Great Reset [ref1](#)

Human 2.0 [ref1](#), [ref2](#)

Israel [ref1](#), [ref2](#)

vaccines [ref1](#)

Wetiko factor [ref1](#)

**social disapproval** [ref1](#)

**social distancing and isolation** [ref1](#), [ref2](#), [ref3](#)

abusive relationships [ref1](#), [ref2](#)

children [ref1](#)

flats and apartments [ref1](#)

heart issues [ref1](#)

hugs [ref1](#)

Internet [ref1](#)

masks [ref1](#)

media [ref1](#)

older people [ref1](#), [ref2](#)

one-metre (three feet) rule [ref1](#)

rewiring the mind [ref1](#)

**simulation, universe as a** [ref1](#)

**SPI-B** [ref1](#)

substance abuse [ref1](#)

suicide and self-harm [ref1](#), [ref2](#), [ref3](#), [ref4](#), [ref5](#)

technology [ref1](#)

torture, as [ref1](#), [ref2](#)

two-metre (six feet) rule [ref1](#)

women [ref1](#)

**social justice** [ref1](#), [ref2](#), [ref3](#), [ref4](#)

**social media** *see also* **Facebook bans on alternative views** [ref1](#)

    censorship [ref1](#), [ref2](#), [ref3](#), [ref4](#), [ref5](#), [ref6](#)

    children [ref1](#)

    emotion [ref1](#)

    perception [ref1](#)

    private messages [ref1](#)

    Twitter [ref1](#), [ref2](#), [ref3](#), [ref4](#), [ref5](#), [ref6](#), [ref7](#)

    Wetiko factor [ref1](#)

    YouTube [ref1](#), [ref2](#), [ref3](#), [ref4](#), [ref5](#)

**Soros, George** [ref1](#), [ref2](#), [ref3](#), [ref4](#), [ref5](#), [ref6](#)

**Spain** [ref1](#)

**SPI-B (Scientific Pandemic Insights Group on Behaviours)** [ref1](#),  
[ref2](#), [ref3](#), [ref4](#)

**spider and the web** [ref1](#), [ref2](#), [ref3](#), [ref4](#)

**Starmer, Keir** [ref1](#)

**Statute Law** [ref1](#)

**Steiner, Rudolf** [ref1](#), [ref2](#), [ref3](#)

**Stockholm syndrome** [ref1](#)

**streptomycin** [ref1](#)

**suicide and self-harm** [ref1](#), [ref2](#), [ref3](#), [ref4](#), [ref5](#)

**Sumer** [ref1](#), [ref2](#)

**Sunstein, Cass** [ref1](#), [ref2](#), [ref3](#)

**swine flu (H1N1)** [ref1](#), [ref2](#), [ref3](#)

**synchronicity** [ref1](#)

**synthetic biology** [ref1](#), [ref2](#), [ref3](#), [ref4](#)

**synthetic meat** [ref1](#), [ref2](#)

## **T**

**technology** *see also* **artificial intelligence (AI); Internet;**

social media addiction [ref1](#), [ref2](#), [ref3](#), [ref4](#)

Archons [ref1](#), [ref2](#)

the cloud [ref1](#), [ref2](#), [ref3](#), [ref4](#), [ref5](#), [ref6](#), [ref7](#)

cyber-operations [ref1](#)

cyberwarfare [ref1](#)

radiation [ref1](#), [ref2](#)

social distancing and isolation [ref1](#)

technocracy [ref1](#)

**Tedros Adhanom Ghebreyesus** [ref1](#), [ref2](#), [ref3](#), [ref4](#), [ref5](#), [ref6](#), [ref7](#),  
[ref8](#), [ref9](#), [ref10](#), [ref11](#), [ref12](#), [ref13](#)

telepathy [ref1](#)

**Tenpenny, Sherri** [ref1](#)

**Tesla, Nikola** [ref1](#)

**testosterone levels, decrease in** [ref1](#)

**testing for Covid-19** [ref1](#), [ref2](#)

anal swab tests [ref1](#)

cancer [ref1](#)

China [ref1](#), [ref2](#), [ref3](#)

Corman-Drosten test [ref1](#), [ref2](#), [ref3](#), [ref4](#)

death certificates [ref1](#), [ref2](#)

fraudulent testing [ref1](#)

genetic material, amplification of [ref1](#)

Lateral Flow Device (LFD) [ref1](#)

PCR tests [ref1](#), [ref2](#), [ref3](#), [ref4](#), [ref5](#), [ref6](#), [ref7](#), [ref8](#)

vaccines [ref1](#), [ref2](#), [ref3](#)

**Thunberg, Greta** [ref1](#), [ref2](#), [ref3](#)

**Totalitarian Tiptoe** [ref1](#), [ref2](#), [ref3](#), [ref4](#)

**transgender persons**

activism [ref1](#)

artificial wombs [ref1](#)

[censorship](#) [ref1](#)  
[child abuse](#) [ref1](#), [ref2](#)  
[Human 2.0](#) [ref1](#), [ref2](#), [ref3](#)  
[Wokeness](#) [ref1](#), [ref2](#), [ref3](#), [ref4](#), [ref5](#)  
[women, deletion of rights and status of](#) [ref1](#), [ref2](#)  
[young persons](#) [ref1](#)

**travel restrictions** [ref1](#)

**Trudeau, Justin** [ref1](#), [ref2](#), [ref3](#)

**Trump, Donald** [ref1](#), [ref2](#), [ref3](#), [ref4](#), [ref5](#), [ref6](#), [ref7](#), [ref8](#), [ref9](#), [ref10](#), [ref11](#)

**Twitter** [ref1](#), [ref2](#), [ref3](#), [ref4](#), [ref5](#), [ref6](#), [ref7](#)

## **U**

**UKColumn** [ref1](#), [ref2](#)

**United Nations (UN)** [ref1](#), [ref2](#), [ref3](#), [ref4](#), [ref5](#) *see also* **Agenda 21/Agenda 2030 (UN)**

**United States** [ref1](#), [ref2](#)

[American Revolution](#) [ref1](#)

[borders](#) [ref1](#), [ref2](#)

[Capitol Hill riot](#) [ref1](#), [ref2](#)

[children](#) [ref1](#)

[China](#) [ref1](#), [ref2](#)

[CIA](#) [ref1](#), [ref2](#)

[Daily Pass tracking system](#) [ref1](#)

[demographics by immigration, changes in](#) [ref1](#)

[Democrats](#) [ref1](#), [ref2](#), [ref3](#), [ref4](#), [ref5](#), [ref6](#), [ref7](#)

[election fraud](#) [ref1](#)

[far-right domestic terrorists, pushbackers as](#) [ref1](#)

[Federal Reserve](#) [ref1](#)

[flu/respiratory diseases statistics](#) [ref1](#)

[Global Cult](#) [ref1](#), [ref2](#)

[hand sanitisers, FDA warnings on](#) [ref1](#)

immigration, effects of illegal [ref1](#)  
impeachment [ref1](#)  
Israel [ref1](#), [ref2](#)  
Judaism [ref1](#), [ref2](#), [ref3](#)  
lockdown [ref1](#)  
masks [ref1](#)  
mass media [ref1](#), [ref2](#)  
nursing homes [ref1](#)  
Pentagon [ref1](#), [ref2](#), [ref3](#), [ref4](#)  
police [ref1](#), [ref2](#), [ref3](#), [ref4](#)  
pushbackers [ref1](#)  
Republicans [ref1](#), [ref2](#)  
borders [ref1](#), [ref2](#)  
Democrats [ref1](#), [ref2](#), [ref3](#), [ref4](#), [ref5](#)  
Russia, inquiry into collusion with [ref1](#)  
Sabbatians [ref1](#), [ref2](#), [ref3](#)  
September 11, 2001, terrorist attacks [ref1](#), [ref2](#), [ref3](#), [ref4](#)  
UFO sightings, release of information on [ref1](#)  
vaccines [ref1](#)  
white supremacy [ref1](#), [ref2](#), [ref3](#), [ref4](#)  
Woke Democrats [ref1](#), [ref2](#)

## **V**

vaccines [ref1](#), [ref2](#), [ref3](#)  
adverse reactions [ref1](#), [ref2](#), [ref3](#), [ref4](#), [ref5](#)  
Africa [ref1](#)  
anaphylactic shock [ref1](#), [ref2](#), [ref3](#), [ref4](#)  
animals [ref1](#), [ref2](#)  
anti-vax movement [ref1](#), [ref2](#), [ref3](#), [ref4](#), [ref5](#)  
AstraZeneca/Oxford [ref1](#), [ref2](#), [ref3](#), [ref4](#)  
autoimmune diseases, rise in [ref1](#), [ref2](#)  
Big Pharma [ref1](#), [ref2](#), [ref3](#), [ref4](#), [ref5](#), [ref6](#), [ref7](#), [ref8](#)



bioweapon, as real [ref1](#), [ref2](#)  
black and ethnic minority communities [ref1](#)  
blood clots [ref1](#), [ref2](#)  
Brain Computer Interface (BCI) [ref1](#)  
care homes, deaths in [ref1](#)  
censorship [ref1](#), [ref2](#), [ref3](#)  
chief medical officers and scientific advisers, financial interests of  
[ref1](#), [ref2](#)  
children [ref1](#), [ref2](#), [ref3](#), [ref4](#), [ref5](#), [ref6](#), [ref7](#), [ref8](#), [ref9](#), [ref10](#)  
China [ref1](#), [ref2](#)  
clinical trials [ref1](#), [ref2](#), [ref3](#), [ref4](#), [ref5](#), [ref6](#)  
compensation [ref1](#)  
compulsory vaccinations [ref1](#), [ref2](#), [ref3](#)  
computer programs [ref1](#)  
consciousness [ref1](#)  
cover-ups [ref1](#)  
creation before Covid [ref1](#)  
cytokine storm [ref1](#)  
deaths and illnesses caused by vaccines [ref1](#), [ref2](#), [ref3](#), [ref4](#), [ref5](#)  
definition [ref1](#)  
developing countries [ref1](#)  
digital tattoos [ref1](#)  
DNA-manipulation [ref1](#), [ref2](#), [ref3](#), [ref4](#), [ref5](#), [ref6](#), [ref7](#), [ref8](#), [ref9](#),  
[ref10](#)  
emergency approval [ref1](#), [ref2](#), [ref3](#), [ref4](#), [ref5](#)  
female infertility [ref1](#)  
funding [ref1](#)  
genetic suicide [ref1](#)  
Global Cult [ref1](#)  
heart chakras [ref1](#)  
hesitancy [ref1](#)  
Human 2.0 [ref1](#), [ref2](#), [ref3](#), [ref4](#)  
immunity from prosecution [ref1](#), [ref2](#), [ref3](#)

implantable technology [ref1](#)  
Israel [ref1](#)  
Johnson & Johnson [ref1](#), [ref2](#), [ref3](#), [ref4](#)  
lockdowns [ref1](#)  
long-term effects [ref1](#)  
mainstream media [ref1](#), [ref2](#), [ref3](#), [ref4](#), [ref5](#)  
masks [ref1](#), [ref2](#), [ref3](#), [ref4](#), [ref5](#)  
Medicines and Healthcare products Regulatory Agency (MHRA)  
[ref1](#), [ref2](#)  
messaging [ref1](#)  
Moderna [ref1](#), [ref2](#), [ref3](#), [ref4](#), [ref5](#), [ref6](#)  
mRNA vaccines [ref1](#), [ref2](#), [ref3](#), [ref4](#), [ref5](#), [ref6](#), [ref7](#), [ref8](#), [ref9](#)  
nanotechnology [ref1](#), [ref2](#)  
NHS [ref1](#), [ref2](#), [ref3](#), [ref4](#), [ref5](#)  
older people [ref1](#), [ref2](#)  
operating system [ref1](#)  
passports [ref1](#), [ref2](#), [ref3](#), [ref4](#)  
Pfizer/BioNTech [ref1](#), [ref2](#), [ref3](#), [ref4](#), [ref5](#), [ref6](#), [ref7](#)  
polyethylene glycol [ref1](#)  
pregnant women [ref1](#)  
psychopathic personality [ref1](#)  
races, targeting different [ref1](#)  
reverse transcription [ref1](#)  
Smart Grid [ref1](#)  
social distancing [ref1](#)  
social media [ref1](#)  
sterility [ref1](#)  
synthetic material, introduction of [ref1](#)  
tests [ref1](#), [ref2](#), [ref3](#)  
travel restrictions [ref1](#)  
**variants** [ref1](#), [ref2](#)  
**viruses, existence of** [ref1](#)  
whistle-blowing [ref1](#)

WHO [ref1](#), [ref2](#), [ref3](#), [ref4](#)  
Wokeness [ref1](#)  
working, vaccine as [ref1](#)  
young people [ref1](#)  
**Vallance, Patrick** [ref1](#), [ref2](#), [ref3](#), [ref4](#), [ref5](#), [ref6](#), [ref7](#), [ref8](#), [ref9](#)  
variants [ref1](#), [ref2](#), [ref3](#)  
vegans [ref1](#)  
ventilators [ref1](#), [ref2](#)  
virology [ref1](#), [ref2](#)  
virtual reality [ref1](#), [ref2](#), [ref3](#)  
viruses, existence of [ref1](#)  
visual reality [ref1](#), [ref2](#)  
vitamin D [ref1](#), [ref2](#)  
von Braun, Wernher [ref1](#), [ref2](#)

## **W**

war-zone hospital myths [ref1](#)  
waveforms [ref1](#), [ref2](#)  
wealth [ref1](#), [ref2](#), [ref3](#), [ref4](#), [ref5](#), [ref6](#), [ref7](#), [ref8](#), [ref9](#) [ref10](#), [ref11](#)  
wet market conspiracy [ref1](#)  
**Wetiko factor** [ref1](#)  
    alcoholism and drug addiction [ref1](#)  
    anti-human, why Global Cult is [ref1](#)  
    Archons [ref1](#), [ref2](#), [ref3](#), [ref4](#)  
    artificial intelligence (AI) [ref1](#)  
    Big Pharma [ref1](#), [ref2](#)  
    children [ref1](#)  
    China [ref1](#)  
    consciousness [ref1](#), [ref2](#)  
    education [ref1](#)  
    Facebook [ref1](#)

fear [ref1](#), [ref2](#)  
frequency [ref1](#), [ref2](#)  
Gates [ref1](#), [ref2](#)  
Global Cult [ref1](#), [ref2](#)  
heart [ref1](#), [ref2](#)  
lockdowns [ref1](#)  
masks [ref1](#)  
Native American concept [ref1](#)  
psychopathic personality [ref1](#), [ref2](#)  
reframing/retraining programmes [ref1](#)  
religion [ref1](#)  
Silicon Valley [ref1](#)  
Smart Grid [ref1](#)  
smartphone addiction [ref1](#), [ref2](#)  
social media [ref1](#)  
war [ref1](#), [ref2](#)  
WHO [ref1](#)  
Wokeness [ref1](#), [ref2](#), [ref3](#)  
Yaldabaoth [ref1](#), [ref2](#), [ref3](#), [ref4](#)  
**whistle-blowing** [ref1](#), [ref2](#), [ref3](#), [ref4](#), [ref5](#), [ref6](#), [ref7](#)  
**white privilege** [ref1](#), [ref2](#)  
**white supremacy** [ref1](#), [ref2](#), [ref3](#), [ref4](#), [ref5](#)  
**Whitty, Christopher** [ref1](#), [ref2](#), [ref3](#), [ref4](#), [ref5](#), [ref6](#), [ref7](#), [ref8](#), [ref9](#),  
[ref10](#)  
**'who benefits'** [ref1](#)  
**Wi-Fi** [ref1](#), [ref2](#), [ref3](#), [ref4](#)  
**Wikipedia** [ref1](#), [ref2](#)  
**Wojcicki, Susan** [ref1](#), [ref2](#), [ref3](#), [ref4](#), [ref5](#), [ref6](#), [ref7](#)  
**Wokeness**  
Antifa [ref1](#), [ref2](#), [ref3](#), [ref4](#)  
anti-Semitism [ref1](#)  
billionaire social justice warriors [ref1](#), [ref2](#), [ref3](#)

Capitol Hill riot [ref1](#), [ref2](#)  
censorship [ref1](#)  
Christianity [ref1](#)  
climate change hoax [ref1](#), [ref2](#)  
culture [ref1](#)  
education, control of [ref1](#)  
emotion [ref1](#)  
facts [ref1](#)  
fascism [ref1](#), [ref2](#), [ref3](#)  
Global Cult [ref1](#), [ref2](#), [ref3](#), [ref4](#)  
group-think [ref1](#)  
immigration [ref1](#)  
indigenous people, solidarity with [ref1](#)  
inversion [ref1](#), [ref2](#), [ref3](#)  
left, hijacking the [ref1](#), [ref2](#)  
Marxism [ref1](#), [ref2](#), [ref3](#)  
mind control [ref1](#)  
New Woke [ref1](#)  
Old Woke [ref1](#)  
Oneness [ref1](#)  
perceptual programming [ref1](#)  
    Phantom Self [ref1](#)  
police [ref1](#)  
defunding the [ref1](#)  
reframing [ref1](#)  
public institutions [ref1](#)  
Pushbackers [ref1](#), [ref2](#), [ref3](#)  
racism [ref1](#), [ref2](#), [ref3](#)  
reframing [ref1](#), [ref2](#)  
religion, as [ref1](#)  
Sabbatians [ref1](#), [ref2](#), [ref3](#)  
Silicon Valley [ref1](#)  
social justice [ref1](#), [ref2](#), [ref3](#), [ref4](#)

transgender [ref1](#), [ref2](#), [ref3](#), [ref4](#), [ref5](#)

United States [ref1](#), [ref2](#)

vaccines [ref1](#)

Wetiko factor [ref1](#), [ref2](#), [ref3](#)

young people [ref1](#), [ref2](#), [ref3](#)

women, deletion of rights and status of [ref1](#), [ref2](#)

World Economic Forum (WEF) [ref1](#), [ref2](#), [ref3](#), [ref4](#), [ref5](#), [ref6](#), [ref7](#),  
[ref8](#), [ref9](#)

World Health Organization (WHO) [ref1](#), [ref2](#), [ref3](#), [ref4](#), [ref5](#), [ref6](#),  
[ref7](#), [ref8](#), [ref9](#)

AIDs/HIV [ref1](#)

amplification cycles [ref1](#)

Big Pharma [ref1](#), [ref2](#), [ref3](#)

cooperation in health emergencies [ref1](#)

creation [ref1](#), [ref2](#)

fatality rate [ref1](#)

funding [ref1](#), [ref2](#), [ref3](#)

Gates [ref1](#)

Internet [ref1](#)

lockdown [ref1](#)

vaccines [ref1](#), [ref2](#), [ref3](#), [ref4](#)

Wetiko factor [ref1](#)

world number 1 (masses) [ref1](#), [ref2](#)

world number 2 [ref1](#)

Wuhan [ref1](#), [ref2](#), [ref3](#), [ref4](#), [ref5](#), [ref6](#), [ref7](#) [ref8](#)

## Y

Yaldabaoth [ref1](#), [ref2](#), [ref3](#), [ref4](#), [ref5](#), [ref6](#)

Yeadon, Michael [ref1](#), [ref2](#), [ref3](#), [ref4](#)

young people *see also* children addiction to technology [ref1](#)

Human 2.0 [ref1](#)

vaccines [ref1](#), [ref2](#)

Wokeness [ref1](#), [ref2](#), [ref3](#)

YouTube [ref1](#), [ref2](#), [ref3](#), [ref4](#), [ref5](#)

WHO 548

## **Z**

Zaks, Tal [ref1](#)

Zionism [ref1](#), [ref2](#), [ref3](#)

Zuckerberg, Mark [ref1](#), [ref2](#), [ref3](#), [ref4](#), [ref5](#), [ref6](#), [ref7](#), [ref8](#), [ref9](#),  
[ref10](#), [ref11](#), [ref12](#)

Zulus [ref1](#)

# **ICKONIC** **THE ALTERNATIVE**

Ickonic is something that has been a dream of mine for the last 5 years, growing up around alternative information I have always had a natural interest in what is going on in the World and what could I do to make it better.

Across the range of subjects and positions of influence occupied mainly by people who don't strive to make things better it's the Media that I have always found the most frustrating and fascinating. Mainly because if the Media did their Jobs properly then so much of the negative things happening in the World simply would not be able to happen, because they would be exposed within a heartbeat.

Free Press and the Opportunities that the internet could have given would mean that the Media are able to expose things like never before and hold people to account for their actions. As we all know there are 'Untouchables' that walk among us, people the Media simply won't touch, expose or investigate and that leads to the dark underworlds that infest the establishment the World over. Well I say enough, it's time for something different, a different kind of Media, where no one is off limits from exposing and investigating. All we're interested in at Ickonic is the truth of what is really going on in the World on whichever subject we're covering.

We hope you enjoy what we have created and take something away from the platform, we aim to deliver information that's informative and most importantly self-empowering, you're not a little person, you're part of something much bigger than that and its time we as a collective race began to understand that and look to the future as ours to take.

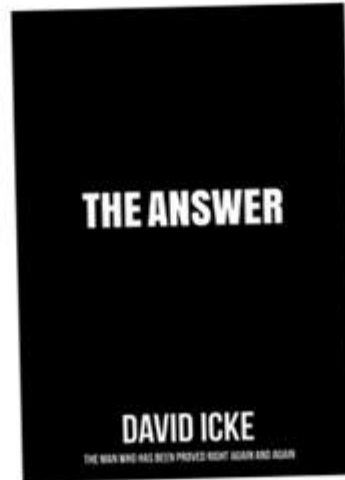
It's time...

Jaymie Icke - Founder Ickonic Alternative Media.

**SIGN UP NOW AT [ICKONIC.COM](http://ICKONIC.COM)**



DAVID ICKE  
**THE ANSWER**



We live in extraordinary times with billions bewildered and seeking answers for what is happening. David Icke, the man who has been proved right again and again, has spent 30 years uncovering the truth behind world affairs and in a stream of previous books he predicted current events.

The Answer will change your every perception of life and the world and set you free of the illusions that control human society. There is nothing more vital for our collective freedom than humanity becoming aware of what is in this book.

**Available now at [davidicke.com](http://davidicke.com).**

# THE TRIGGER

THE LIE THAT CHANGED THE WORLD  
- WHO REALLY DID IT AND WHY



DAVID ICKE



**EVERYTHING  
YOU NEED  
TO KNOW**

**BUT HAVE NEVER BEEN TOLD**

**DAVID ICKE**

**DAVIDICKE.COM**



**DAVID ICKE STORE**  
**LATEST NEWS ARTICLES**  
**DAVID ICKE VIDEOS**  
**WEEKLY DOT-CONNECTOR PODCASTS**  
**LIVE EVENTS**

[WWW.DAVIDICKE.COM](http://WWW.DAVIDICKE.COM)

THE LIFE STORY OF DAVID ICKE

# RENEGADE

THE FEATURE LENGTH FILM

/ˈren·iːgeɪd/

**noun**

A person who behaves in a rebelliously unconventional manner.



AVAILABLE NOW AT [DAVIDICKE.COM](http://DAVIDICKE.COM)

2 NEW BOOKS  
BY NEIL HAGUE

# ORION'S DOOR

SYMBOLS OF CONSCIOUSNESS & BLUEPRINTS OF CONTROL  
- THE STORY OF ORION'S INFLUENCE OVER HUMANITY

CUTTING EDGE VISIONARY ART  
& UNIQUE ILLUSTRATED BOOKS

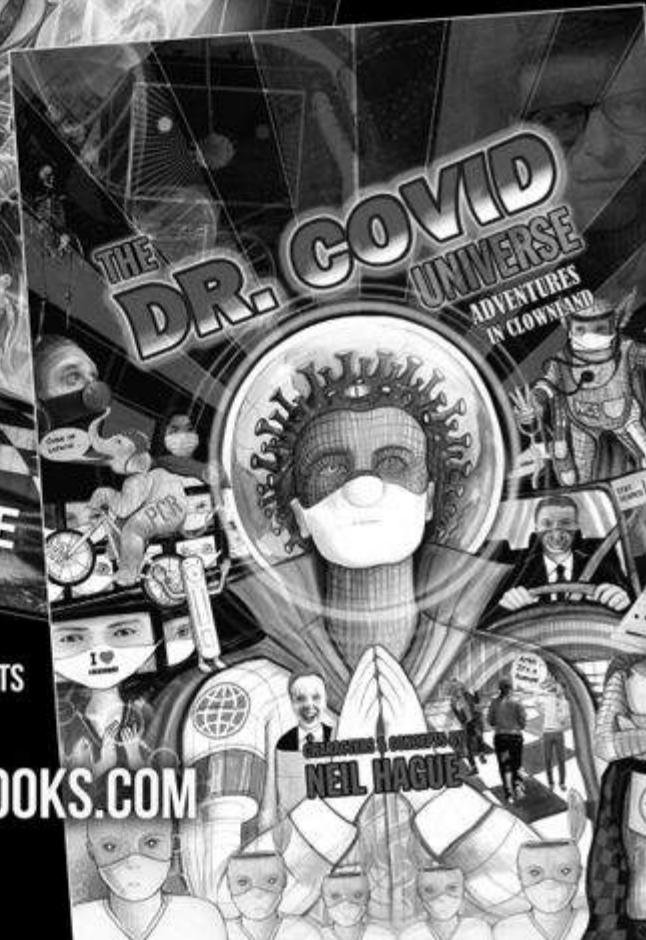
NEIL HAGUE

FOR  
BOOKS, PRINTS & T-SHIRTS

VISIT:

[NEILHAGUEBOOKS.COM](http://NEILHAGUEBOOKS.COM)

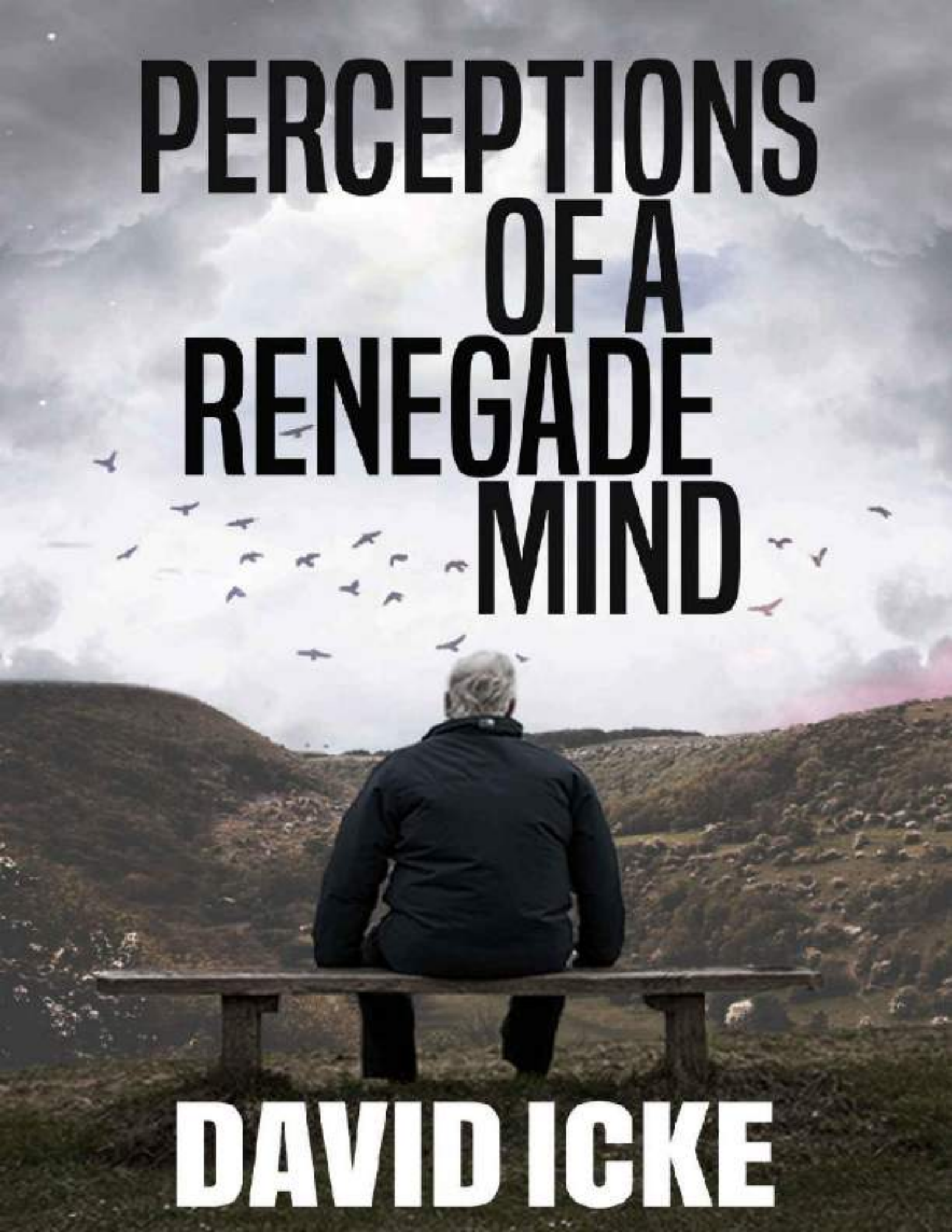
OR [NEILHAGUE.COM](http://NEILHAGUE.COM)



## **Before you go ...**

For more detail, background and evidence about the subjects in *Perceptions of a Renegade Mind* – and so much more – see my others books including *And The Truth Shall Set You Free*; *The Biggest Secret*; *Children of the Matrix*; *The David Icke Guide to the Global Conspiracy*; *Tales from the Time Loop*; *The Perception Deception*; *Remember Who You Are*; *Human Race Get Off Your Knees*; *Phantom Self*; *Everything You Need To Know But Have Never Been Told*, *The Trigger* and *The Answer*.

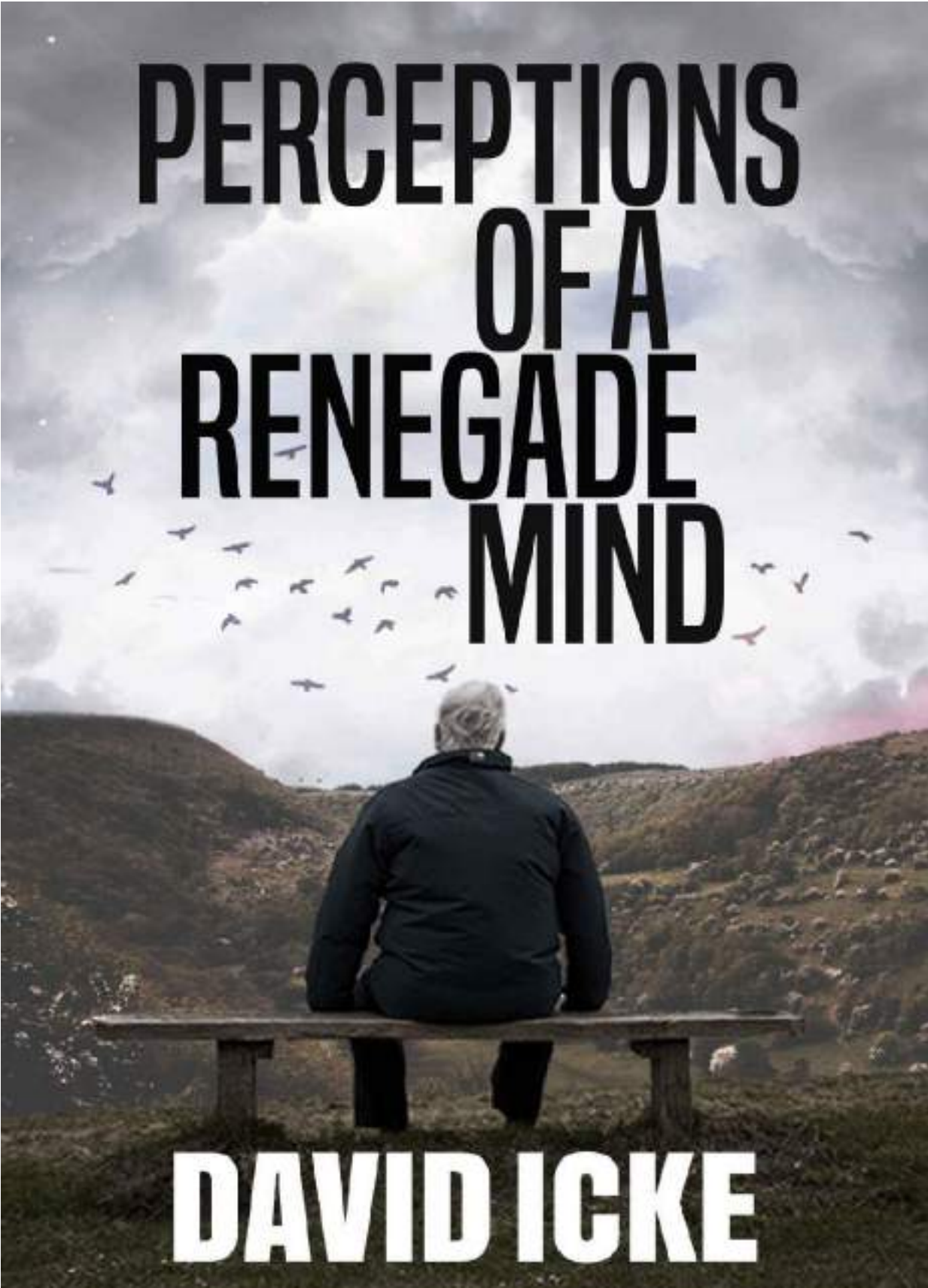
You can subscribe to the fantastic new Ickonic media platform where there are many hundreds of hours of cutting-edge information in videos, documentaries and series across a whole range of subjects which are added to every week. This includes my 90 minute breakdown of the week's news every Friday to explain *why* events are happening and to what end.

A person with grey hair, wearing a dark jacket, is seen from behind, sitting on a wooden bench. They are looking out over a vast, open landscape of rolling hills under a cloudy sky. Numerous birds are flying in the sky, scattered across the upper half of the image. The overall mood is contemplative and serene.

# PERCEPTIONS OF A RENEGADE MIND

**DAVID ICKE**





**PERCEPTIONS  
OF A  
RENEGADE  
MIND**

**DAVID ICKE**

**PERCEPTIONS  
OF A  
RENEGADE  
MIND**



ickonic  
publishing

First published in July 2021.

ickonic  
publishing

**New Enterprise House  
St Helens Street  
Derby  
DE1 3GY  
UK**

*email:* [gareth.icke@davidicke.com](mailto:gareth.icke@davidicke.com)

Copyright © 2021 David Icke

No part of this book may be reproduced in any form without permission from the  
Publisher, except for the quotation of brief passages in criticism

*Cover Design:* Gareth Icke  
*Book Design:* Neil Hague

**British Library Cataloguing-in  
Publication Data**  
A catalogue record for this book is  
available from the British Library

eISBN 978-18384153-1-0

**PERCEPTIONS  
OF A  
RENEGADE  
MIND**

A flock of small, dark birds is scattered around the bottom half of the title text, appearing to fly in various directions.

**DAVID ICKE**

**Dedication:**

***To Freeeeedom!***

# **ICKONIC** **THE ALTERNATIVE**

**NEW. DIFFERENT. REVOLUTIONARY**

**HUNDREDS OF CUTTING EDGE DOCUMENTARIES,  
FEATURE FILMS, SERIES & PODCASTS.**

**SIGN UP NOW AT [ICKONIC.COM](http://ICKONIC.COM)**

THE LIFE STORY OF DAVID ICKE  
**RENEGADE**  
THE FEATURE LENGTH FILM



AVAILABLE NOW AT [DAVIDICKE.COM](http://DAVIDICKE.COM)

**Renegade:**

Adjective

'Having rejected tradition: Unconventional.'

**Merriam-Webster Dictionary**



## **Acquiescence to tyranny is the death of the spirit**

You may be 38 years old, as I happen to be. And one day, some great opportunity stands before you and calls you to stand up for some great principle, some great issue, some great cause. And you refuse to do it because you are afraid ... You refuse to do it because you want to live longer ... You're afraid that you will lose your job, or you are afraid that you will be criticised or that you will lose your popularity, or you're afraid that somebody will stab you, or shoot at you or bomb your house; so you refuse to take the stand.

Well, you may go on and live until you are 90, but you're just as dead at 38 as you would be at 90. And the cessation of breathing in your life is but the belated announcement of an earlier death of the spirit.

**Martin Luther King**

**How the few control the many and always have – the many do  
whatever they're told**

'Forward, the Light Brigade!'  
Was there a man dismayed?  
Not though the soldier knew  
Someone had blundered.  
Theirs not to make reply,  
Theirs not to reason why,  
Theirs but to do and die.  
Into the valley of Death  
Rode the six hundred.

Cannon to right of them,  
Cannon to left of them,  
Cannon in front of them  
Volleyed and thundered;  
Stormed at with shot and shell,  
Boldly they rode and well,  
Into the jaws of Death,  
Into the mouth of hell  
Rode the six hundred

**Alfred Lord Tennyson (1809-1892)**

The mist is lifting slowly  
I can see the way ahead  
And I've left behind the empty streets  
That once inspired my life  
And the strength of the emotion  
Is like thunder in the air  
'Cos the promise that we made each other  
Haunts me to the end

The secret of your beauty  
And the mystery of your soul  
I've been searching for in everyone I meet  
And the times I've been mistaken  
It's impossible to say  
And the grass is growing  
Underneath our feet

The words that I remember  
From my childhood still are true  
That there's none so blind  
As those who will not see  
And to those who lack the courage  
And say it's dangerous to try  
Well they just don't know  
That love eternal will not be denied

I know you're out there somewhere  
Somewhere, somewhere  
I know you're out there somewhere

Somewhere you can hear my voice  
I know I'll find you somehow  
Somehow, somehow  
I know I'll find you somehow  
And somehow I'll return again to you

**The Moody Blues**

**Are you a gutless wonder - or a Renegade Mind?**

Monuments put from pen to paper,  
Turns me into a gutless wonder,  
And if you tolerate this,  
Then your children will be next.  
Gravity keeps my head down,  
Or is it maybe shame ...

**Manic Street Preachers**

Rise like lions after slumber  
In unvanquishable number.  
Shake your chains to earth like dew  
Which in sleep have fallen on you.  
Ye are many – they are few.

**Percy Shelley**

# Contents

CHAPTER 1	'I'm thinking' – Oh, but <i>are</i> you?
CHAPTER 2	Renegade perception
CHAPTER 3	The Pushbacker sting
CHAPTER 4	'Covid': The calculated catastrophe
CHAPTER 5	There <i>is no</i> 'virus'
CHAPTER 6	Sequence of deceit
CHAPTER 7	War on your mind
CHAPTER 8	'Reframing' insanity
CHAPTER 9	We must have it? So what is it?
CHAPTER 10	Human 2.0
CHAPTER 11	Who controls the Cult?
CHAPTER 12	Escaping Wetiko
POSTSCRIPT	
APPENDIX	Cowan-Kaufman-Morell Statement on Virus Isolation
BIBLIOGRAPHY	
INDEX	

## CHAPTER ONE

### **I'm thinking' – Oh, but *are* you?**

*Think for yourself and let others enjoy the privilege of doing so too*  
Voltaire

**F**rench-born philosopher, mathematician and scientist René Descartes became famous for his statement in Latin in the 17th century which translates into English as: 'I think, therefore I am.'

On the face of it that is true. Thought reflects perception and perception leads to both behaviour and self-identity. In that sense 'we' are what we think. But who or what is doing the thinking and is thinking the only route to perception? Clearly, as we shall see, 'we' are not always the source of 'our' perception, indeed with regard to humanity as a whole this is rarely the case; and thinking is far from the only means of perception. Thought is the village idiot compared with other expressions of consciousness that we all have the potential to access and tap into. This has to be true when we *are* those other expressions of consciousness which are infinite in nature. We have forgotten this, or, more to the point, been manipulated to forget.

These are not just the esoteric musings of the navel. The whole foundation of human control and oppression is control of perception. Once perception is hijacked then so is behaviour which is dictated by perception. Collective perception becomes collective behaviour and collective behaviour is what we call human society. Perception is all and those behind human control know that which is

why perception is the target 24/7 of the psychopathic manipulators that I call the Global Cult. They know that if they dictate perception they will dictate behaviour and collectively dictate the nature of human society. They are further aware that perception is formed from information received and if they control the circulation of information they will to a vast extent direct human behaviour. Censorship of information and opinion has become globally Nazi-like in recent years and never more blatantly than since the illusory 'virus pandemic' was triggered out of China in 2019 and across the world in 2020. Why have billions submitted to house arrest and accepted fascistic societies in a way they would have never believed possible? Those controlling the information spewing from government, mainstream media and Silicon Valley (all controlled by the same Global Cult networks) told them they were in danger from a 'deadly virus' and only by submitting to house arrest and conceding their most basic of freedoms could they and their families be protected. This monumental and provable lie became the *perception* of the billions and therefore the *behaviour* of the billions. In those few words you have the whole structure and modus operandi of human control. Fear is a perception – False Emotion Appearing Real – and fear is the currency of control. In short ... get them by the balls (or give them the impression that you have) and their hearts and minds will follow. Nothing grips the dangly bits and freezes the rear-end more comprehensively than fear.

## **World number 1**

There are two 'worlds' in what appears to be one 'world' and the prime difference between them is knowledge. First we have the mass of human society in which the population is maintained in coldly-calculated ignorance through control of information and the 'education' (indoctrination) system. That's all you really need to control to enslave billions in a perceptual delusion in which what are perceived to be *their* thoughts and opinions are ever-repeated mantras that the system has been downloading all their lives through 'education', media, science, medicine, politics and academia



in which the personnel and advocates are themselves overwhelmingly the perceptual products of the same repetition. Teachers and academics in general are processed by the same programming machine as everyone else, but unlike the great majority they never leave the 'education' program. It gripped them as students and continues to grip them as programmers of subsequent generations of students. The programmed become the programmers – the programmed programmers. The same can largely be said for scientists, doctors and politicians and not least because as the American writer Upton Sinclair said: 'It is difficult to get a man to understand something when his salary depends upon his not understanding it.' If your career and income depend on thinking the way the system demands then you will – bar a few free-minded exceptions – concede your mind to the Perceptual Mainframe that I call the Postage Stamp Consensus. This is a tiny band of perceived knowledge and possibility 'taught' (downloaded) in the schools and universities, pounded out by the mainstream media and on which all government policy is founded. Try thinking, and especially speaking and acting, outside of the 'box' of consensus and see what that does for your career in the Mainstream Everything which bullies, harasses, intimidates and ridicules the population into compliance. Here we have the simple structure which enslaves most of humanity in a perceptual prison cell for an entire lifetime and I'll go deeper into this process shortly. Most of what humanity is taught as fact is nothing more than programmed belief. American science fiction author Frank Herbert was right when he said: 'Belief can be manipulated. Only knowledge is dangerous.' In the 'Covid' age belief is promoted and knowledge is censored. It was always so, but never to the extreme of today.

## **World number 2**

A 'number 2' is slang for 'doing a poo' and how appropriate that is when this other 'world' is doing just that on humanity every minute of every day. World number 2 is a global network of secret societies and semi-secret groups dictating the direction of society via

governments, corporations and authorities of every kind. I have spent more than 30 years uncovering and exposing this network that I call the Global Cult and knowing its agenda is what has made my books so accurate in predicting current and past events. Secret societies are secret for a reason. They want to keep their hoarded knowledge to themselves and their chosen initiates and to hide it from the population which they seek through ignorance to control and subdue. The whole foundation of the division between World 1 and World 2 is *knowledge*. What number 1 knows number 2 must not. Knowledge they have worked so hard to keep secret includes (a) the agenda to enslave humanity in a centrally-controlled global dictatorship, and (b) the nature of reality and life itself. The latter (b) must be suppressed to allow the former (a) to prevail as I shall be explaining. The way the Cult manipulates and interacts with the population can be likened to a spider's web. The 'spider' sits at the centre in the shadows and imposes its will through the web with each strand represented in World number 2 by a secret society, satanic or semi-secret group, and in World number 1 – the world of the seen – by governments, agencies of government, law enforcement, corporations, the banking system, media conglomerates and Silicon Valley (Fig 1 overleaf). The spider and the web connect and coordinate all these organisations to pursue the same global outcome while the population sees them as individual entities working randomly and independently. At the level of the web governments *are* the banking system *are* the corporations *are* the media *are* Silicon Valley *are* the World Health Organization working from their inner cores as one unit. Apparently unconnected countries, corporations, institutions, organisations and people are on the *same team* pursuing the same global outcome. Strands in the web immediately around the spider are the most secretive and exclusive secret societies and their membership is emphatically restricted to the Cult inner-circle emerging through the generations from particular bloodlines for reasons I will come to. At the core of the core you would get them in a single room. That's how many people are dictating the direction of human society and its transformation

through the 'Covid' hoax and other means. As the web expands out from the spider we meet the secret societies that many people will be aware of – the Freemasons, Knights Templar, Knights of Malta, Opus Dei, the inner sanctum of the Jesuit Order, and such like. Note how many are connected to the Church of Rome and there is a reason for that. The Roman Church was established as a revamp, a rebranding, of the relocated 'Church' of Babylon and the Cult imposing global tyranny today can be tracked back to Babylon and Sumer in what is now Iraq.



**Figure 1:** The global web through which the few control the many. (Image Neil Hague.)

Inner levels of the web operate in the unseen away from the public eye and then we have what I call the cusp organisations located at the point where the hidden meets the seen. They include a series of satellite organisations answering to a secret society founded in London in the late 19th century called the Round Table and among them are the Royal Institute of International Affairs (UK, founded in 1920); Council on Foreign Relations (US, 1921); Bilderberg Group (worldwide, 1954); Trilateral Commission (US/worldwide, 1972); and the Club of Rome (worldwide, 1968) which was created to exploit environmental concerns to justify the centralisation of global power to 'save the planet'. The Club of Rome instigated with others the human-caused climate change hoax which has led to all the 'green

new deals' demanding that very centralisation of control. Cusp organisations, which include endless 'think tanks' all over the world, are designed to coordinate a single global policy between political and business leaders, intelligence personnel, media organisations and anyone who can influence the direction of policy in their own sphere of operation. Major players and regular attenders will know what is happening – or some of it – while others come and go and are kept overwhelmingly in the dark about the big picture. I refer to these cusp groupings as semi-secret in that they can be publicly identified, but what goes on at the inner-core is kept very much 'in house' even from most of their members and participants through a fiercely-imposed system of compartmentalisation. Only let them know what they need to know to serve your interests and no more. The structure of secret societies serves as a perfect example of this principle. Most Freemasons never get higher than the bottom three levels of 'degree' (degree of knowledge) when there are 33 official degrees of the Scottish Rite. Initiates only qualify for the next higher 'compartment' or degree if those at that level choose to allow them. Knowledge can be carefully assigned only to those considered 'safe'. I went to my local Freemason's lodge a few years ago when they were having an 'open day' to show how cuddly they were and when I chatted to some of them I was astonished at how little the rank and file knew even about the most ubiquitous symbols they use. The mushroom technique – keep them in the dark and feed them bullshit – applies to most people in the web as well as the population as a whole. Sub-divisions of the web mirror in theme and structure transnational corporations which have a headquarters somewhere in the world dictating to all their subsidiaries in different countries. Subsidiaries operate in their methodology and branding to the same centrally-dictated plan and policy in pursuit of particular ends. The Cult web functions in the same way. Each country has its own web as a subsidiary of the global one. They consist of networks of secret societies, semi-secret groups and bloodline families and their job is to impose the will of the spider and the global web in their particular country. Subsidiary networks control and manipulate the national political system, finance, corporations, media, medicine, etc. to

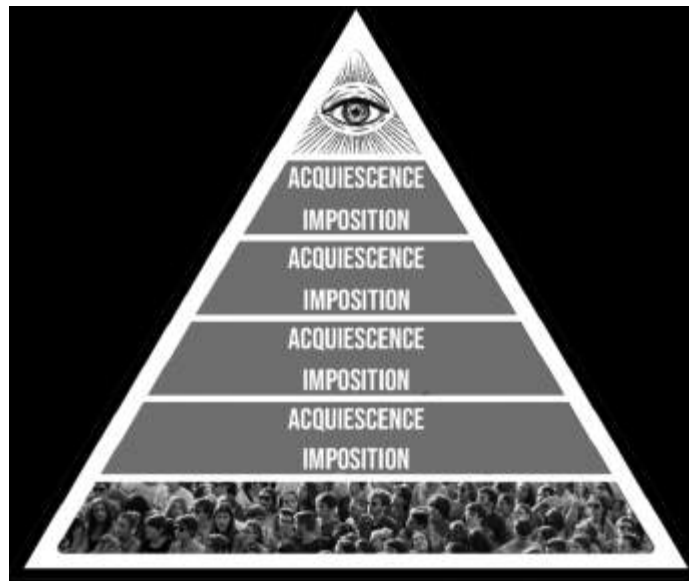
ensure that they follow the globally-dictated Cult agenda. These networks were the means through which the 'Covid' hoax could be played out with almost every country responding in the same way.

## **The 'Yessir' pyramid**

Compartmentalisation is the key to understanding how a tiny few can dictate the lives of billions when combined with a top-down sequence of imposition and acquiescence. The inner core of the Cult sits at the peak of the pyramidal hierarchy of human society (Fig 2 overleaf). It imposes its will – its agenda for the world – on the level immediately below which acquiesces to that imposition. This level then imposes the Cult will on the level below them which acquiesces and imposes on the next level. Very quickly we meet levels in the hierarchy that have no idea there even is a Cult, but the sequence of imposition and acquiescence continues down the pyramid in just the same way. 'I don't know why we are doing this but the order came from "on-high" and so we better just do it.' Alfred Lord Tennyson said of the cannon fodder levels in his poem *The Charge of the Light Brigade*: 'Theirs not to reason why; theirs but to do and die.' The next line says that 'into the valley of death rode the six hundred' and they died because they obeyed without question what their perceived 'superiors' told them to do. In the same way the population capitulated to 'Covid'. The whole hierarchical pyramid functions like this to allow the very few to direct the enormous many.

Eventually imposition-acquiescence-imposition-acquiescence comes down to the mass of the population at the foot of the pyramid. If they acquiesce to those levels of the hierarchy imposing on them (governments/law enforcement/doctors/media) a circuit is completed between the population and the handful of super-psychopaths in the Cult inner core at the top of the pyramid. Without a circuit-breaking refusal to obey, the sequence of imposition and acquiescence allows a staggeringly few people to impose their will upon the entirety of humankind. We are looking at the very sequence that has subjugated billions since the start of 2020. Our freedom has not been taken from us. Humanity has given it

away. Fascists do not impose fascism because there are not enough of them. Fascism is imposed by the population acquiescing to fascism. Put another way allowing their perceptions to be programmed to the extent that leads to the population giving their freedom away by giving their perceptions – their mind – away. If this circuit is not broken by humanity ceasing to cooperate with their own enslavement then nothing can change. For that to happen people have to critically think and see through the lies and window dressing and then summon the backbone to act upon what they see. The Cult spends its days working to stop either happening and its methodology is systematic and highly detailed, but it can be overcome and that is what this book is all about.



**Figure 2:** The simple sequence of imposition and compliance that allows a handful of people at the peak of the pyramid to dictate the lives of billions.

## **The Life Program**

Okay, back to world number 1 or the world of the 'masses'. Observe the process of what we call 'life' and it is a perceptual download from cradle to grave. The Cult has created a global structure in which perception can be programmed and the program continually topped-up with what appears to be constant confirmation that the program is indeed true reality. The important word here is 'appears'.

This is the structure, the fly-trap, the Postage Stamp Consensus or Perceptual Mainframe, which represents that incredibly narrow band of perceived possibility delivered by the 'education' system, mainstream media, science and medicine. From the earliest age the download begins with parents who have themselves succumbed to the very programming their children are about to go through. Most parents don't do this out of malevolence and mostly it is quite the opposite. They do what they believe is best for their children and that is what the program has told them is best. Within three or four years comes the major transition from parental programming to full-blown state (Cult) programming in school, college and university where perceptually-programmed teachers and academics pass on their programming to the next generations. Teachers who resist are soon marginalised and their careers ended while children who resist are called a problem child for whom Ritalin may need to be prescribed. A few years after entering the 'world' children are under the control of authority figures representing the state telling them when they have to be there, when they can leave and when they can speak, eat, even go to the toilet. This is calculated preparation for a lifetime of obeying authority in all its forms. Reflex-action fear of authority is instilled by authority from the start. Children soon learn the carrot and stick consequences of obeying or defying authority which is underpinned daily for the rest of their life. Fortunately I daydreamed through this crap and never obeyed authority simply because it told me to. This approach to my alleged 'betters' continues to this day. There can be consequences of pursuing open-minded freedom in a world of closed-minded conformity. I spent a lot of time in school corridors after being ejected from the classroom for not taking some of it seriously and now I spend a lot of time being ejected from Facebook, YouTube and Twitter. But I can tell you that being true to yourself and not compromising your self-respect is far more exhilarating than bowing to authority for authority's sake. You don't have to be a sheep to the shepherd (authority) and the sheep dog (fear of not obeying authority).

The perceptual download continues throughout the formative years in school, college and university while script-reading 'teachers', 'academics' 'scientists', 'doctors' and 'journalists' insist that ongoing generations must be as programmed as they are. Accept the program or you will not pass your 'exams' which confirm your 'degree' of programming. It is tragic to think that many parents pressure their offspring to work hard at school to download the program and qualify for the next stage at college and university. The late, great, American comedian George Carlin said: 'Here's a bumper sticker I'd like to see: We are proud parents of a child who has resisted his teachers' attempts to break his spirit and bend him to the will of his corporate masters.' Well, the best of luck finding many of those, George. Then comes the moment to leave the formal programming years in academia and enter the 'adult' world of work. There you meet others in your chosen or prescribed arena who went through the same Postage Stamp Consensus program before you did. There is therefore overwhelming agreement between almost everyone on the basic foundations of Postage Stamp reality and the rejection, even contempt, of the few who have a mind of their own and are prepared to use it. This has two major effects. Firstly, the consensus confirms to the programmed that their download is really how things are. I mean, everyone knows that, right? Secondly, the arrogance and ignorance of Postage Stamp adherents ensure that anyone questioning the program will have unpleasant consequences for seeking their own truth and not picking their perceptions from the shelf marked: 'Things you must believe without question and if you don't you're a dangerous lunatic conspiracy theorist and a harebrained nutter'.

Every government, agency and corporation is founded on the same Postage Stamp prison cell and you can see why so many people believe the same thing while calling it their own 'opinion'. Fusion of governments and corporations in pursuit of the same agenda was the definition of fascism described by Italian dictator Benito Mussolini. The pressure to conform to perceptual norms downloaded for a lifetime is incessant and infiltrates society right



down to family groups that become censors and condemners of their own 'black sheep' for not, ironically, being sheep. We have seen an explosion of that in the 'Covid' era. Cult-owned global media unleashes its propaganda all day every day in support of the Postage Stamp and targets with abuse and ridicule anyone in the public eye who won't bend their mind to the will of the tyranny. Any response to this is denied (certainly in my case). They don't want to give a platform to expose official lies. Cult-owned-and-created Internet giants like Facebook, Google, YouTube and Twitter delete you for having an unapproved opinion. Facebook boasts that its AI censors delete 97-percent of 'hate speech' before anyone even reports it. Much of that 'hate speech' will simply be an opinion that Facebook and its masters don't want people to see. Such perceptual oppression is widely known as fascism. Even Facebook executive Benny Thomas, a 'CEO Global Planning Lead', said in comments secretly recorded by investigative journalism operation Project Veritas that Facebook is 'too powerful' and should be broken up:

I mean, no king in history has been the ruler of two billion people, but Mark Zuckerberg is ... And he's 36. That's too much for a 36-year-old ... You should not have power over two billion people. I just think that's wrong.

Thomas said Facebook-owned platforms like Instagram, Oculus, and WhatsApp needed to be separate companies. 'It's too much power when they're all one together'. That's the way the Cult likes it, however. We have an executive of a Cult organisation in Benny Thomas that doesn't know there is a Cult such is the compartmentalisation. Thomas said that Facebook and Google 'are no longer companies, they're countries'. Actually they are more powerful than countries on the basis that if you control information you control perception and control human society.

## **I love my oppressor**

Another expression of this psychological trickery is for those who realise they are being pressured into compliance to eventually

convince themselves to believe the official narratives to protect their self-respect from accepting the truth that they have succumbed to meek and subservient compliance. Such people become some of the most vehement defenders of the system. You can see them everywhere screaming abuse at those who prefer to think for themselves and by doing so reminding the compliers of their own capitulation to conformity. 'You are talking dangerous nonsense you Covidiot!!' Are you trying to convince me or yourself? It is a potent form of Stockholm syndrome which is defined as: 'A psychological condition that occurs when a victim of abuse identifies and attaches, or bonds, positively with their abuser.' An example is hostages bonding and even 'falling in love' with their kidnappers. The syndrome has been observed in domestic violence, abused children, concentration camp inmates, prisoners of war and many and various Satanic cults. These are some traits of Stockholm syndrome listed at [goodtherapy.org](http://goodtherapy.org):

- Positive regard towards perpetrators of abuse or captor [see 'Covid'].
- Failure to cooperate with police and other government authorities when it comes to holding perpetrators of abuse or kidnapping accountable [or in the case of 'Covid' cooperating with the police to enforce and defend their captors' demands].
- Little or no effort to escape [see 'Covid'].
- Belief in the goodness of the perpetrators or kidnappers [see 'Covid'].
- Appeasement of captors. This is a manipulative strategy for maintaining one's safety. As victims get rewarded – perhaps with less abuse or even with life itself – their appeasing behaviours are reinforced [see 'Covid'].
- Learned helplessness. This can be akin to 'if you can't beat 'em, join 'em'. As the victims fail to escape the abuse or captivity, they may start giving up and soon realize it's just easier for everyone if they acquiesce all their power to their captors [see 'Covid'].

- Feelings of pity toward the abusers, believing they are actually victims themselves. Because of this, victims may go on a crusade or mission to 'save' [protect] their abuser [see the venom unleashed on those challenging the official 'Covid' narrative].
- Unwillingness to learn to detach from their perpetrators and heal. In essence, victims may tend to be less loyal to themselves than to their abuser [ *definitely* see 'Covid'].

Ponder on those traits and compare them with the behaviour of great swathes of the global population who have defended governments and authorities which have spent every minute destroying their lives and livelihoods and those of their children and grandchildren since early 2020 with fascistic lockdowns, house arrest and employment deletion to 'protect' them from a 'deadly virus' that their abusers' perceptually created to bring about this very outcome. We are looking at mass Stockholm syndrome. All those that agree to concede their freedom will believe those perceptions are originating in their own independent 'mind' when in fact by conceding their reality to Stockholm syndrome they have by definition conceded any independence of mind. Listen to the 'opinions' of the acquiescing masses in this 'Covid' era and what gushes forth is the repetition of the official version of everything delivered unprocessed, unfiltered and unquestioned. The whole programming dynamic works this way. I must be free because I'm told that I am and so I think that I am.

You can see what I mean with the chapter theme of 'I'm thinking – Oh, but *are* you?' The great majority are not thinking, let alone for themselves. They are repeating what authority has told them to believe which allows them to be controlled. Weaving through this mentality is the fear that the 'conspiracy theorists' are right and this again explains the often hysterical abuse that ensues when you dare to contest the official narrative of anything. Denial is the mechanism of hiding from yourself what you don't want to be true. Telling people what they want to hear is easy, but it's an infinitely greater challenge to tell them what they would rather not be happening.

One is akin to pushing against an open door while the other is met with vehement resistance no matter what the scale of evidence. I don't want it to be true so I'll convince myself that it's not. Examples are everywhere from the denial that a partner is cheating despite all the signs to the reflex-action rejection of any idea that world events in which country after country act in exactly the same way are centrally coordinated. To accept the latter is to accept that a force of unspeakable evil is working to destroy your life and the lives of your children with nothing too horrific to achieve that end. Who the heck wants that to be true? But if we don't face reality the end is duly achieved and the consequences are far worse and ongoing than breaking through the walls of denial today with the courage to make a stand against tyranny.

### **Connect the dots – but how?**

A crucial aspect of perceptual programming is to portray a world in which everything is random and almost nothing is connected to anything else. Randomness cannot be coordinated by its very nature and once you perceive events as random the idea they could be connected is waved away as the rantings of the tinfoil-hat brigade. You can't plan and coordinate random you idiot! No, you can't, but you can hide the coldly-calculated and long-planned behind the *illusion* of randomness. A foundation manifestation of the Renegade Mind is to scan reality for patterns that connect the apparently random and turn pixels and dots into pictures. This is the way I work and have done so for more than 30 years. You look for similarities in people, modus operandi and desired outcomes and slowly, then ever quicker, the picture forms. For instance: There would seem to be no connection between the 'Covid pandemic' hoax and the human-caused global-warming hoax and yet they are masks (appropriately) on the same face seeking the same outcome. Those pushing the global warming myth through the Club of Rome and other Cult agencies are driving the lies about 'Covid' – Bill Gates is an obvious one, but they are endless. Why would the same people be involved in both when they are clearly not connected? Oh, but they

are. Common themes with personnel are matched by common goals. The 'solutions' to both 'problems' are centralisation of global power to impose the will of the few on the many to 'save' humanity from 'Covid' and save the planet from an 'existential threat' (we need 'zero Covid' and 'zero carbon emissions'). These, in turn, connect with the 'dot' of globalisation which was coined to describe the centralisation of global power in every area of life through incessant political and corporate expansion, trading blocks and superstates like the European Union. If you are the few and you want to control the many you have to centralise power and decision-making. The more you centralise power the more power the few at the centre will have over the many; and the more that power is centralised the more power those at the centre have to centralise even quicker. The momentum of centralisation gets faster and faster which is exactly the process we have witnessed. In this way the hoaxed 'pandemic' and the fakery of human-caused global warming serve the interests of globalisation and the seizure of global power in the hands of the Cult inner-circle which is behind 'Covid', 'climate change' and globalisation. At this point random 'dots' become a clear and obvious picture or pattern.

Klaus Schwab, the classic Bond villain who founded the Cult's Gates-funded World Economic Forum, published a book in 2020, *The Great Reset*, in which he used the 'problem' of 'Covid' to justify a total transformation of human society to 'save' humanity from 'climate change'. Schwab said: 'The pandemic represents a rare but narrow window of opportunity to reflect, reimagine, and reset our world.' What he didn't mention is that the Cult he serves is behind both hoaxes as I show in my book *The Answer*. He and the Cult don't have to reimagine the world. They know precisely what they want and that's why they destroyed human society with 'Covid' to 'build back better' in their grand design. Their job is not to imagine, but to get humanity to imagine and agree with their plans while believing it's all random. It must be pure coincidence that 'The Great Reset' has long been the Cult's code name for the global imposition of fascism and replaced previous code-names of the 'New World

Order' used by Cult frontmen like Father George Bush and the 'New Order of the Ages' which emerged from Freemasonry and much older secret societies. New Order of the Ages appears on the reverse of the Great Seal of the United States as 'Novus ordo seclorum' underneath the Cult symbol used since way back of the pyramid and all seeing-eye (Fig 3). The pyramid is the hierarchy of human control headed by the illuminated eye that symbolises the force behind the Cult which I will expose in later chapters. The term 'Annuit Coeptis' translates as 'He favours our undertaking'. We are told the 'He' is the Christian god, but 'He' is not as I will be explaining.



**Figure 3:** The all-seeing eye of the Cult 'god' on the Freemason-designed Great Seal of the United States and also on the dollar bill.

## **Having you on**

Two major Cult techniques of perceptual manipulation that relate to all this are what I have called since the 1990s Problem-Reaction-Solution (PRS) and the Totalitarian Tiptoe (TT). They can be uncovered by the inquiring mind with a simple question: Who benefits? The answer usually identifies the perpetrators of a given action or happening through the concept of 'he who most benefits from a crime is the one most likely to have committed it'. The Latin 'Cue bono?' – Who benefits? – is widely attributed to the Roman orator and statesman Marcus Tullius Cicero. No wonder it goes back so far when the concept has been relevant to human behaviour since

history was recorded. Problem-Reaction-Solution is the technique used to manipulate us every day by covertly creating a problem (or the illusion of one) and offering the solution to the problem (or the illusion of one). In the first phase you create the problem and blame someone or something else for why it has happened. This may relate to a financial collapse, terrorist attack, war, global warming or pandemic, anything in fact that will allow you to impose the 'solution' to change society in the way you desire at that time. The 'problem' doesn't have to be real. PRS is manipulation of perception and all you need is the population to believe the problem is real. Human-caused global warming and the 'Covid pandemic' only have to be *perceived* to be real for the population to accept the 'solutions' of authority. I refer to this technique as NO-Problem-Reaction-Solution. Billions did not meekly accept house arrest from early 2020 because there was a real deadly 'Covid pandemic' but because they perceived – believed – that to be the case. The antidote to Problem-Reaction-Solution is to ask who benefits from the proposed solution. Invariably it will be anyone who wants to justify more control through deletion of freedom and centralisation of power and decision-making.

The two world wars were Problem-Reaction-Solutions that transformed and realigned global society. Both were manipulated into being by the Cult as I have detailed in books since the mid-1990s. They dramatically centralised global power, especially World War Two, which led to the United Nations and other global bodies thanks to the overt and covert manipulations of the Rockefeller family and other Cult bloodlines like the Rothschilds. The UN is a stalking horse for full-blown world government that I will come to shortly. The land on which the UN building stands in New York was donated by the Rockefellers and the same Cult family was behind Big Pharma scalpel and drug 'medicine' and the creation of the World Health Organization as part of the UN. They have been stalwarts of the eugenics movement and funded Hitler's race-purity expert' Ernst Rudin. The human-caused global warming hoax has been orchestrated by the Club of Rome through the UN which is

manufacturing both the 'problem' through its Intergovernmental Panel on Climate Change and imposing the 'solution' through its Agenda 21 and Agenda 2030 which demand the total centralisation of global power to 'save the world' from a climate hoax the United Nations is itself perpetrating. What a small world the Cult can be seen to be particularly among the inner circles. The bedfellow of Problem-Reaction-Solution is the Totalitarian Tiptoe which became the Totalitarian Sprint in 2020. The technique is fashioned to hide the carefully-coordinated behind the cover of apparently random events. You start the sequence at 'A' and you know you are heading for 'Z'. You don't want people to know that and each step on the journey is presented as a random happening while all the steps strung together lead in the same direction. The speed may have quickened dramatically in recent times, but you can still see the incremental approach of the Tiptoe in the case of 'Covid' as each new imposition takes us deeper into fascism. Tell people they have to do this or that to get back to 'normal', then this and this and this. With each new demand adding to the ones that went before the population's freedom is deleted until it disappears. The spider wraps its web around the flies more comprehensively with each new diktat. I'll highlight this in more detail when I get to the 'Covid' hoax and how it has been pulled off. Another prime example of the Totalitarian Tiptoe is how the Cult-created European Union went from a 'free-trade zone' to a centralised bureaucratic dictatorship through the Tiptoe of incremental centralisation of power until nations became mere administrative units for Cult-owned dark suits in Brussels.

The antidote to ignorance is knowledge which the Cult seeks vehemently to deny us, but despite the systematic censorship to that end the Renegade Mind can overcome this by vociferously seeking out the facts no matter the impediments put in the way. There is also a method of thinking and perceiving – *knowing* – that doesn't even need names, dates, place-type facts to identify the patterns that reveal the story. I'll get to that in the final chapter. All you need to know about the manipulation of human society and to what end is still out there – *at the time of writing* – in the form of books, videos



and websites for those that really want to breach the walls of programmed perception. To access this knowledge requires the abandonment of the mainstream media as a source of information in the awareness that this is owned and controlled by the Cult and therefore promotes mass perceptions that suit the Cult. Mainstream media lies all day, every day. That is its function and very reason for being. Where it does tell the truth, here and there, is only because the truth and the Cult agenda very occasionally coincide. If you look for fact and insight to the BBC, CNN and virtually all the rest of them you are asking to be conned and perceptually programmed.

### **Know the outcome and you'll see the journey**

Events seem random when you have no idea where the world is being taken. Once you do the random becomes the carefully planned. Know the outcome and you'll see the journey is a phrase I have been using for a long time to give context to daily happenings that appear unconnected. Does a problem, or illusion of a problem, trigger a proposed 'solution' that further drives society in the direction of the outcome? Invariably the answer will be yes and the random – *abracadabra* – becomes the clearly coordinated. So what is this outcome that unlocks the door to a massively expanded understanding of daily events? I will summarise its major aspects – the fine detail is in my other books – and those new to this information will see that the world they thought they were living in is a very different place. The foundation of the Cult agenda is the incessant centralisation of power and all such centralisation is ultimately in pursuit of Cult control on a global level. I have described for a long time the planned world structure of top-down dictatorship as the Hunger Games Society. The term obviously comes from the movie series which portrayed a world in which a few living in military-protected hi-tech luxury were the overlords of a population condemned to abject poverty in isolated 'sectors' that were not allowed to interact. 'Covid' lockdowns and travel bans anyone? The 'Hunger Games' pyramid of structural control has the inner circle of the Cult at the top with pretty much the entire

population at the bottom under their control through dependency for survival on the Cult. The whole structure is planned to be protected and enforced by a military-police state (Fig 4).

Here you have the reason for the global lockdowns of the fake pandemic to coldly destroy independent incomes and livelihoods and make everyone dependent on the 'state' (the Cult that controls the 'states'). I have warned in my books for many years about the plan to introduce a 'guaranteed income' – a barely survivable pittance – designed to impose dependency when employment was destroyed by AI technology and now even more comprehensively at great speed by the 'Covid' scam. Once the pandemic was played and lockdown consequences began to delete independent income the authorities began to talk right on cue about the need for a guaranteed income and a 'Great Reset'. Guaranteed income will be presented as benevolent governments seeking to help a desperate people – desperate as a direct result of actions of the same governments. The truth is that such payments are a trap. You will only get them if you do exactly what the authorities demand including mass vaccination (genetic manipulation). We have seen this theme already in Australia where those dependent on government benefits have them reduced if parents don't agree to have their children vaccinated according to an insane health-destroying government-dictated schedule. Calculated economic collapse applies to governments as well as people. The Cult wants rid of countries through the creation of a world state with countries broken up into regions ruled by a world government and super states like the European Union. Countries must be bankrupted, too, to this end and it's being achieved by the trillions in 'rescue packages' and furlough payments, trillions in lost taxation, and money-no-object spending on 'Covid' including constant all-medium advertising (programming) which has made the media dependent on government for much of its income. The day of reckoning is coming – as planned – for government spending and given that it has been made possible by printing money and not by production/taxation there is inflation on the way that has the

potential to wipe out monetary value. In that case there will be no need for the Cult to steal your money. It just won't be worth anything (see the German Weimar Republic before the Nazis took over). Many have been okay with lockdowns while getting a percentage of their income from so-called furlough payments without having to work. Those payments are dependent, however, on people having at least a theoretical job with a business considered non-essential and ordered to close. As these business go under because they are closed by lockdown after lockdown the furlough stops and it will for everyone eventually. Then what? The 'then what?' is precisely the idea.



**Figure 4:** The Hunger Games Society structure I have long warned was planned and now the 'Covid' hoax has made it possible. This is the real reason for lockdowns.

## Hired hands

Between the Hunger Games Cult elite and the dependent population is planned to be a vicious military-police state (a fusion of the two into one force). This has been in the making for a long time with police looking ever more like the military and carrying weapons to match. The pandemic scam has seen this process accelerate so fast as

lockdown house arrest is brutally enforced by carefully recruited fascist minds and gormless system-servers. The police and military are planned to merge into a centrally-directed world army in a global structure headed by a world government which wouldn't be elected even by the election fixes now in place. The world army is not planned even to be human and instead wars would be fought, primarily against the population, using robot technology controlled by artificial intelligence. I have been warning about this for decades and now militaries around the world are being transformed by this very AI technology. The global regime that I describe is a particular form of fascism known as a technocracy in which decisions are not made by clueless and co-opted politicians but by unelected technocrats – scientists, engineers, technologists and bureaucrats. Cult-owned-and-controlled Silicon Valley giants are examples of technocracy and they already have far more power to direct world events than governments. They are with their censorship *selecting* governments. I know that some are calling the 'Great Reset' a Marxist communist takeover, but fascism and Marxism are different labels for the same tyranny. Tell those who lived in fascist Germany and Stalinist Russia that there was a difference in the way their freedom was deleted and their lives controlled. I could call it a fascist technocracy or a Marxist technocracy and they would be equally accurate. The Hunger Games society with its world government structure would oversee a world army, world central bank and single world cashless currency imposing its will on a microchipped population (Fig 5). Scan its different elements and see how the illusory pandemic is forcing society in this very direction at great speed. Leaders of 23 countries and the World Health Organization (WHO) backed the idea in March, 2021, of a global treaty for 'international cooperation' in 'health emergencies' and nations should 'come together as a global community for peaceful cooperation that extends beyond this crisis'. Cut the Orwellian bullshit and this means another step towards global government. The plan includes a cashless digital money system that I first warned about in 1993. Right at the start of 'Covid' the deeply corrupt Tedros

Adhanom Ghebreyesus, the crooked and merely gofer 'head' of the World Health Organization, said it was possible to catch the 'virus' by touching cash and it was better to use cashless means. The claim was ridiculous nonsense and like the whole 'Covid' mind-trick it was nothing to do with 'health' and everything to do with pushing every aspect of the Cult agenda. As a result of the Tedros lie the use of cash has plummeted. The Cult script involves a single world digital currency that would eventually be technologically embedded in the body. China is a massive global centre for the Cult and if you watch what is happening there you will know what is planned for everywhere. The Chinese government is developing a digital currency which would allow fines to be deducted immediately via AI for anyone caught on camera breaking its fantastic list of laws and the money is going to be programmable with an expiry date to ensure that no one can accrue wealth except the Cult and its operatives.



**Figure 5:** The structure of global control the Cult has been working towards for so long and this has been enormously advanced by the 'Covid' illusion.

## **Serfdom is so smart**

The Cult plan is far wider, extreme, and more comprehensive than even most conspiracy researchers appreciate and I will come to the true depths of deceit and control in the chapters 'Who controls the

Cult?’ and ‘Escaping Wetiko’. Even the world that we know is crazy enough. We are being deluged with ever more sophisticated and controlling technology under the heading of ‘smart’. We have smart televisions, smart meters, smart cards, smart cars, smart driving, smart roads, smart pills, smart patches, smart watches, smart skin, smart borders, smart pavements, smart streets, smart cities, smart communities, smart environments, smart growth, smart planet ... smart *everything* around us. Smart technologies and methods of operation are designed to interlock to create a global Smart Grid connecting the entirety of human society including human minds to create a centrally-dictated ‘hive’ mind. ‘Smart cities’ is code for densely-occupied megacities of total surveillance and control through AI. Ever more destructive frequency communication systems like 5G have been rolled out without any official testing for health and psychological effects (colossal). 5G/6G/7G systems are needed to run the Smart Grid and each one becomes more destructive of body and mind. Deleting independent income is crucial to forcing people into these AI-policed prisons by ending private property ownership (except for the Cult elite). The Cult’s Great Reset now openly foresees a global society in which no one will own any possessions and everything will be rented while the Cult would own literally everything under the guise of government and corporations. The aim has been to use the lockdowns to destroy sources of income on a mass scale and when the people are destitute and in unrepayable amounts of debt (problem) Cult assets come forward with the pledge to write-off debt in return for handing over all property and possessions (solution). Everything – literally everything including people – would be connected to the Internet via AI. I was warning years ago about the coming Internet of Things (IoT) in which all devices and technology from your car to your fridge would be plugged into the Internet and controlled by AI. Now we are already there with much more to come. The next stage is the Internet of Everything (IoE) which is planned to include the connection of AI to the human brain and body to replace the human mind with a centrally-controlled AI mind. Instead of perceptions

being manipulated through control of information and censorship those perceptions would come direct from the Cult through AI. What do you think? You think whatever AI decides that you think. In human terms there would be no individual 'think' any longer. Too incredible? The ravings of a lunatic? Not at all. Cult-owned crazies in Silicon Valley have been telling us the plan for years without explaining the real motivation and calculated implications. These include Google executive and 'futurist' Ray Kurzweil who highlights the year 2030 for when this would be underway. He said:

Our thinking ... will be a hybrid of biological and non-biological thinking ... humans will be able to extend their limitations and 'think in the cloud' ... We're going to put gateways to the cloud in our brains ... We're going to gradually merge and enhance ourselves ... In my view, that's the nature of being human – we transcend our limitations.

As the technology becomes vastly superior to what we are then the small proportion that is still human gets smaller and smaller and smaller until it's just utterly negligible.

The sales-pitch of Kurzweil and Cult-owned Silicon Valley is that this would make us 'super-human' when the real aim is to make us post-human and no longer 'human' in the sense that we have come to know. The entire global population would be connected to AI and become the centrally-controlled 'hive-mind' of externally-delivered perceptions. The Smart Grid being installed to impose the Cult's will on the world is being constructed to allow particular locations – even one location – to control the whole global system. From these prime control centres, which absolutely include China and Israel, anything connected to the Internet would be switched on or off and manipulated at will. Energy systems could be cut, communication via the Internet taken down, computer-controlled driverless autonomous vehicles driven off the road, medical devices switched off, the potential is limitless given how much AI and Internet connections now run human society. We have seen nothing yet if we allow this to continue. Autonomous vehicle makers are working with law enforcement to produce cars designed to automatically pull over if they detect a police or emergency vehicle flashing from up to 100 feet away. At a police stop the car would be unlocked and the

window rolled down automatically. Vehicles would only take you where the computer (the state) allowed. The end of petrol vehicles and speed limiters on all new cars in the UK and EU from 2022 are steps leading to electric computerised transport over which ultimately you have no control. The picture is far bigger even than the Cult global network or web and that will become clear when I get to the nature of the 'spider'. There is a connection between all these happenings and the instigation of DNA-manipulating 'vaccines' (which aren't 'vaccines') justified by the 'Covid' hoax. That connection is the unfolding plan to transform the human body from a biological to a synthetic biological state and this is why synthetic biology is such a fast-emerging discipline of mainstream science. 'Covid vaccines' are infusing self-replicating synthetic genetic material into the cells to cumulatively take us on the Totalitarian Tiptoe from Human 1.0 to the synthetic biological Human 2.0 which will be physically and perceptually attached to the Smart Grid to one hundred percent control every thought, perception and deed. Humanity needs to wake up and *fast*.

This is the barest explanation of where the 'outcome' is planned to go but it's enough to see the journey happening all around us. Those new to this information will already see 'Covid' in a whole new context. I will add much more detail as we go along, but for the minutiae evidence see my mega-works, *The Answer*, *The Trigger* and *Everything You Need to Know But Have Never Been Told*.

Now – how does a Renegade Mind see the 'world'?



## CHAPTER TWO

# Renegade Perception

*It is one thing to be clever and another to be wise*

George R.R. Martin

A simple definition of the difference between a programmed mind and a Renegade Mind would be that one sees only dots while the other connects them to see the picture. Reading reality with accuracy requires the observer to (a) know the planned outcome and (b) realise that everything, but *everything*, is connected.

The entirety of infinite reality is connected – that’s its very nature – and with human society an expression of infinite reality the same must apply. Simple cause and effect is a connection. The effect is triggered by the cause and the effect then becomes the cause of another effect. Nothing happens in isolation because it *can’t*. Life in whatever reality is simple choice and consequence. We make choices and these lead to consequences. If we don’t like the consequences we can make different choices and get different consequences which lead to other choices and consequences. The choice and the consequence are not only connected they are indivisible. You can’t have one without the other as an old song goes. A few cannot control the world unless those being controlled allow that to happen – cause and effect, choice and consequence. Control – who has it and who doesn’t – is a two-way process, a symbiotic relationship, involving the controller and controlled. ‘They took my freedom away!!’ Well, yes, but you also gave it to them. Humanity is

subjected to mass control because humanity has acquiesced to that control. This is all cause and effect and literally a case of give and take. In the same way world events of every kind are connected and the Cult works incessantly to sell the illusion of the random and coincidental to maintain the essential (to them) perception of dots that hide the picture. Renegade Minds know this and constantly scan the world for patterns of connection. This is absolutely pivotal in understanding the happenings in the world and without that perspective clarity is impossible. First you know the planned outcome and then you identify the steps on the journey – the day-by-day apparently random which, when connected in relation to the outcome, no longer appear as individual events, but as the proverbial *chain* of events leading in the same direction. I'll give you some examples:

### **Political puppet show**

We are told to believe that politics is 'adversarial' in that different parties with different beliefs engage in an endless tussle for power. There may have been some truth in that up to a point – and only a point – but today divisions between 'different' parties are rhetorical not ideological. Even the rhetorical is fusing into one-speak as the parties eject any remaining free thinkers while others succumb to the ever-gathering intimidation of anyone with the 'wrong' opinion. The Cult is not a new phenomenon and can be traced back thousands of years as my books have documented. Its intergenerational initiatives have been manipulating events with increasing effect the more that global power has been centralised. In ancient times the Cult secured control through the system of monarchy in which 'special' bloodlines (of which more later) demanded the right to rule as kings and queens simply by birthright and by vanquishing others who claimed the same birthright. There came a time, however, when people had matured enough to see the unfairness of such tyranny and demanded a say in who governed them. Note the word – *governed* them. Not served them – *governed* them, hence government defined as 'the political direction and control exercised over the

actions of the members, citizens, or inhabitants of communities, societies, and states; direction of the affairs of a state, community, etc.' Governments exercise control over rather than serve just like the monarchies before them. Bizarrely there are still countries like the United Kingdom which are ruled by a monarch *and* a government that officially answers to the monarch. The UK head of state and that of Commonwealth countries such as Canada, Australia and New Zealand is 'selected' by who in a *single family* had unprotected sex with whom and in what order. Pinch me it can't be true. Ouch! Shit, it is. The demise of monarchies in most countries offered a potential vacuum in which some form of free and fair society could arise and the Cult had that base covered. Monarchies had served its interests but they couldn't continue in the face of such widespread opposition and, anyway, replacing a 'royal' dictatorship that people could see with a dictatorship 'of the people' hiding behind the concept of 'democracy' presented far greater manipulative possibilities and ways of hiding coordinated tyranny behind the illusion of 'freedom'.

Democracy is quite wrongly defined as government selected by the population. This is not the case at all. It is government selected by *some* of the population (and then only in theory). This 'some' doesn't even have to be the majority as we have seen so often in first-past-the-post elections in which the so-called majority party wins fewer votes than the 'losing' parties combined. Democracy can give total power to a party in government from a minority of the votes cast. It's a sleight of hand to sell tyranny as freedom. Seventy-four million Trump-supporting Americans didn't vote for the 'Democratic' Party of Joe Biden in the distinctly dodgy election in 2020 and yet far from acknowledging the wishes and feelings of that great percentage of American society the Cult-owned Biden government set out from day one to destroy them and their right to a voice and opinion. Empty shell Biden and his Cult handlers said they were doing this to 'protect democracy'. Such is the level of lunacy and sickness to which politics has descended. Connect the dots and relate them to the desired outcome – a world government run by self-appointed technocrats and no longer even elected

politicians. While operating through its political agents in government the Cult is at the same time encouraging public disdain for politicians by putting idiots and incompetents in theoretical power on the road to deleting them. The idea is to instil a public reaction that says of the technocrats: 'Well, they couldn't do any worse than the pathetic politicians.' It's all about controlling perception and Renegade Minds can see through that while programmed minds cannot when they are ignorant of both the planned outcome and the manipulation techniques employed to secure that end. This knowledge can be learned, however, and fast if people choose to get informed.

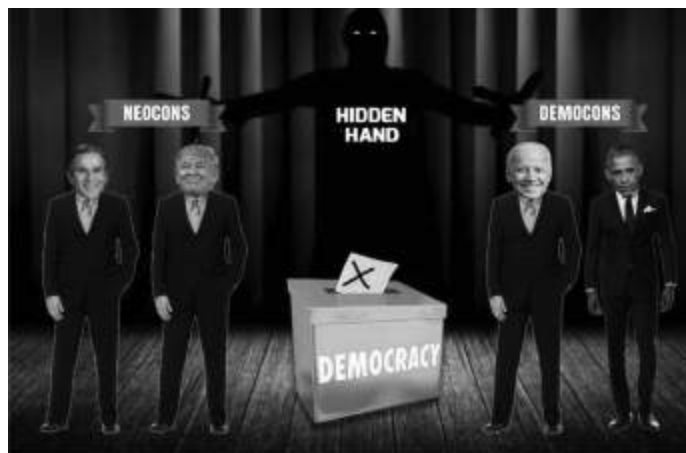
Politics may at first sight appear very difficult to control from a central point. I mean look at the 'different' parties and how would you be able to oversee them all and their constituent parts? In truth, it's very straightforward because of their structure. We are back to the pyramid of imposition and acquiescence. Organisations are structured in the same way as the system as a whole. Political parties are not open forums of free expression. They are hierarchies. I was a national spokesman for the British Green Party which claimed to be a different kind of politics in which influence and power was devolved; but I can tell you from direct experience – and it's far worse now – that Green parties are run as hierarchies like all the others however much they may try to hide that fact or kid themselves that it's not true. A very few at the top of all political parties are directing policy and personnel. They decide if you are elevated in the party or serve as a government minister and to do that you have to be a yes man or woman. Look at all the maverick political thinkers who never ascended the greasy pole. If you want to progress within the party or reach 'high-office' you need to fall into line and conform. Exceptions to this are rare indeed. Should you want to run for parliament or Congress you have to persuade the local or state level of the party to select you and for that you need to play the game as dictated by the hierarchy. If you secure election and wish to progress within the greater structure you need to go on conforming to what is acceptable to those running the hierarchy

from the peak of the pyramid. Political parties are perceptual gulags and the very fact that there are party 'Whips' appointed to 'whip' politicians into voting the way the hierarchy demands exposes the ridiculous idea that politicians are elected to serve the people they are supposed to represent. Cult operatives and manipulation has long seized control of major parties that have any chance of forming a government and at least most of those that haven't. A new party forms and the Cult goes to work to infiltrate and direct. This has reached such a level today that you see video compilations of 'leaders' of all parties whether Democrats, Republicans, Conservative, Labour and Green parroting the same Cult mantra of 'Build Back Better' and the 'Great Reset' which are straight off the Cult song-sheet to describe the transformation of global society in response to the Cult-instigated hoaxes of the 'Covid pandemic' and human-caused 'climate change'. To see Caroline Lucas, the Green Party MP that I knew when I was in the party in the 1980s, speaking in support of plans proposed by Cult operative Klaus Schwab representing the billionaire global elite is a real head-shaker.

### **Many parties – one master**

The party system is another mind-trick and was instigated to change the nature of the dictatorship by swapping 'royalty' for dark suits that people believed – though now ever less so – represented their interests. Understanding this trick is to realise that a single force (the Cult) controls all parties either directly in terms of the major ones or through manipulation of perception and ideology with others. You don't need to manipulate Green parties to demand your transformation of society in the name of 'climate change' when they are obsessed with the lie that this is essential to 'save the planet'. You just give them a platform and away they go serving your interests while believing they are being environmentally virtuous. America's political structure is a perfect blueprint for how the two or multi-party system is really a one-party state. The Republican Party is controlled from one step back in the shadows by a group made up of billionaires and their gofers known as neoconservatives or Neocons.

I have exposed them in fine detail in my books and they were the driving force behind the policies of the imbecilic presidency of Boy George Bush which included 9/11 (see *The Trigger* for a comprehensive demolition of the official story), the subsequent 'war on terror' (war of terror) and the invasions of Afghanistan and Iraq. The latter was a No-Problem-Reaction-Solution based on claims by Cult operatives, including Bush and British Prime Minister Tony Blair, about Saddam Hussein's 'weapons of mass destruction' which did not exist as war criminals Bush and Blair well knew.



**Figure 6:** Different front people, different parties – same control system.

The Democratic Party has its own 'Neocon' group controlling from the background which I call the 'Democons' and here's the penny-drop – the Neocons and Democons answer to the same masters one step further back into the shadows (Fig 6). At that level of the Cult the Republican and Democrat parties are controlled by the same people and no matter which is in power the Cult is in power. This is how it works in almost every country and certainly in Britain with Conservative, Labour, Liberal Democrat and Green parties now all on the same page whatever the rhetoric may be in their feeble attempts to appear different. Neocons operated at the time of Bush through a think tank called The Project for the New American Century which in September, 2000, published a document entitled *Rebuilding America's Defenses: Strategies, Forces, and Resources*

*For a New Century* demanding that America fight ‘multiple, simultaneous major theatre wars’ as a ‘core mission’ to force regime-change in countries including Iraq, Libya and Syria. Neocons arranged for Bush (‘Republican’) and Blair (‘Labour Party’) to front-up the invasion of Iraq and when they departed the Democons orchestrated the targeting of Libya and Syria through Barack Obama (‘Democrat’) and British Prime Minister David Cameron (‘Conservative Party’). We have ‘different’ parties and ‘different’ people, but the same unfolding script. The more the Cult has seized the reigns of parties and personnel the more their policies have transparently pursued the same agenda to the point where the fascist ‘Covid’ impositions of the Conservative junta of Jackboot Johnson in Britain were opposed by the Labour Party because they were not fascist enough. The Labour Party is likened to the US Democrats while the Conservative Party is akin to a British version of the Republicans and on both sides of the Atlantic they all speak the same language and support the direction demanded by the Cult although some more enthusiastically than others. It’s a similar story in country after country because it’s all centrally controlled. Oh, but what about Trump? I’ll come to him shortly. Political ‘choice’ in the ‘party’ system goes like this: You vote for Party A and they get into government. You don’t like what they do so next time you vote for Party B and they get into government. You don’t like what they do when it’s pretty much the same as Party A and why wouldn’t that be with both controlled by the same force? Given that only two, sometimes three, parties have any chance of forming a government to get rid of Party B that you don’t like you have to vote again for Party A which ... you don’t like. This, ladies and gentlemen, is what they call ‘democracy’ which we are told – wrongly – is a term interchangeable with ‘freedom’.

## **The cult of cults**

At this point I need to introduce a major expression of the Global Cult known as Sabbatian-Frankism. Sabbatian is also spelt as Sabbatean. I will summarise here. I have published major exposés

and detailed background in other works. Sabbatian-Frankism combines the names of two frauds posing as 'Jewish' men, Sabbatai Zevi (1626-1676), a rabbi, black magician and occultist who proclaimed he was the Jewish messiah; and Jacob Frank (1726-1791), the Polish 'Jew', black magician and occultist who said he was the reincarnation of 'messiah' Zevi and biblical patriarch Jacob. They worked across two centuries to establish the Sabbatian-Frankist cult that plays a major, indeed central, role in the manipulation of human society by the Global Cult which has its origins much further back in history than Sabbatai Zevi. I should emphasise two points here in response to the shrill voices that will scream 'anti-Semitism': (1) Sabbatian-Frankists are NOT Jewish and only pose as such to hide their cult behind a Jewish façade; and (2) my information about this cult has come from Jewish sources who have long realised that their society and community has been infiltrated and taken over by interloper Sabbatian-Frankists. Infiltration has been the foundation technique of Sabbatian-Frankism from its official origin in the 17th century. Zevi's Sabbatian sect attracted a massive following described as the biggest messianic movement in Jewish history, spreading as far as Africa and Asia, and he promised a return for the Jews to the 'Promised Land' of Israel. Sabbatianism was not Judaism but an inversion of everything that mainstream Judaism stood for. So much so that this sinister cult would have a feast day when Judaism had a fast day and whatever was forbidden in Judaism the Sabbatians were encouraged and even commanded to do. This included incest and what would be today called Satanism. Members were forbidden to marry outside the sect and there was a system of keeping their children ignorant of what they were part of until they were old enough to be trusted not to unknowingly reveal anything to outsiders. The same system is employed to this day by the Global Cult in general which Sabbatian-Frankism has enormously influenced and now largely controls.

Zevi and his Sabbatians suffered a setback with the intervention by the Sultan of the Islamic Ottoman Empire in the Middle East and what is now the Republic of Turkey where Zevi was located. The



Sultan gave him the choice of proving his 'divinity', converting to Islam or facing torture and death. Funnily enough Zevi chose to convert or at least appear to. Some of his supporters were disillusioned and drifted away, but many did not with 300 families also converting – only in theory – to Islam. They continued behind this Islamic smokescreen to follow the goals, rules and rituals of Sabbatianism and became known as 'crypto-Jews' or the 'Dönme' which means 'to turn'. This is rather ironic because they didn't 'turn' and instead hid behind a fake Islamic persona. The process of appearing to be one thing while being very much another would become the calling card of Sabbatianism especially after Zevi's death and the arrival of the Satanist Jacob Frank in the 18th century when the cult became Sabbatian-Frankism and plumbed still new depths of depravity and infiltration which included – still includes – human sacrifice and sex with children. Wherever Sabbatians go paedophilia and Satanism follow and is it really a surprise that Hollywood is so infested with child abuse and Satanism when it was established by Sabbatian-Frankists and is still controlled by them? Hollywood has been one of the prime vehicles for global perceptual programming and manipulation. How many believe the version of 'history' portrayed in movies when it is a travesty and inversion (again) of the truth? Rabbi Marvin Antelman describes Frankism in his book, *To Eliminate the Opiate*, as 'a movement of complete evil' while Jewish professor Gershom Scholem said of Frank in *The Messianic Idea in Judaism*: 'In all his actions [he was] a truly corrupt and degenerate individual ... one of the most frightening phenomena in the whole of Jewish history.' Frank was excommunicated by traditional rabbis, as was Zevi, but Frank was undeterred and enjoyed vital support from the House of Rothschild, the infamous banking dynasty whose inner-core are Sabbatian-Frankists and not Jews. Infiltration of the Roman Church and Vatican was instigated by Frank with many Dönme 'turning' again to convert to Roman Catholicism with a view to hijacking the reins of power. This was the ever-repeating modus operandi and continues to be so. Pose as an advocate of the religion, culture or country that you want to control and then

manipulate your people into the positions of authority and influence largely as advisers, administrators and Svengalis for those that appear to be in power. They did this with Judaism, Christianity (Christian Zionism is part of this), Islam and other religions and nations until Sabbatian-Frankism spanned the world as it does today.

### **Sabbatian Saudis and the terror network**

One expression of the Sabbatian-Frankist Dönme within Islam is the ruling family of Saudi Arabia, the House of Saud, through which came the vile distortion of Islam known as Wahhabism. This is the violent creed followed by terrorist groups like Al-Qaeda and ISIS or Islamic State. Wahhabism is the hand-chopping, head-chopping 'religion' of Saudi Arabia which is used to keep the people in a constant state of fear so the interloper House of Saud can continue to rule. Al-Qaeda and Islamic State were lavishly funded by the House of Saud while being created and directed by the Sabbatian-Frankist network in the United States that operates through the Pentagon, CIA and the government in general of whichever 'party'. The front man for the establishment of Wahhabism in the middle of the 18th century was a Sabbatian-Frankist 'crypto-Jew' posing as Islamic called Muhammad ibn Abd al-Wahhab. His daughter would marry the son of Muhammad bin Saud who established the first Saudi state before his death in 1765 with support from the British Empire. Bin Saud's successors would establish modern Saudi Arabia in league with the British and Americans in 1932 which allowed them to seize control of Islam's major shrines in Mecca and Medina. They have dictated the direction of Sunni Islam ever since while Iran is the major centre of the Shiite version and here we have the source of at least the public conflict between them. The Sabbatian network has used its Wahhabi extremists to carry out Problem-Reaction-Solution terrorist attacks in the name of 'Al-Qaeda' and 'Islamic State' to justify a devastating 'war on terror', ever-increasing surveillance of the population and to terrify people into compliance. Another insight of the Renegade Mind is the streetwise understanding that

just because a country, location or people are attacked doesn't mean that those apparently representing that country, location or people are not behind the attackers. Often they are *orchestrating* the attacks because of the societal changes that can be then justified in the name of 'saving the population from terrorists'.

I show in great detail in *The Trigger* how Sabbatian-Frankists were the real perpetrators of 9/11 and not '19 Arab hijackers' who were blamed for what happened. Observe what was justified in the name of 9/11 alone in terms of Middle East invasions, mass surveillance and control that fulfilled the demands of the Project for the New American Century document published by the Sabbatian Neocons. What appear to be enemies are on the deep inside players on the same Sabbatian team. Israel and Arab 'royal' dictatorships are all ruled by Sabbatians and the recent peace agreements between Israel and Saudi Arabia, the United Arab Emirates (UAE) and others are only making formal what has always been the case behind the scenes. Palestinians who have been subjected to grotesque tyranny since Israel was bombed and terrorised into existence in 1948 have never stood a chance. Sabbatian-Frankists have controlled Israel (so the constant theme of violence and war which Sabbatians love) and they have controlled the Arab countries that Palestinians have looked to for real support that never comes. 'Royal families' of the Arab world in Saudi Arabia, Bahrain, UAE, etc., are all Sabbatians with allegiance to the aims of the cult and not what is best for their Arabic populations. They have stolen the oil and financial resources from their people by false claims to be 'royal dynasties' with a genetic right to rule and by employing vicious militaries to impose their will.

### **Satanic 'illumination'**

The Satanist Jacob Frank formed an alliance in 1773 with two other Sabbatians, Mayer Amschel Rothschild (1744-1812), founder of the Rothschild banking dynasty, and Jesuit-educated fraudulent Jew, Adam Weishaupt, and this led to the formation of the Bavarian Illuminati, firstly under another name, in 1776. The Illuminati would

be the manipulating force behind the French Revolution (1789-1799) and was also involved in the American Revolution (1775-1783) before and after the Illuminati's official creation. Weishaupt would later become (in public) a Protestant Christian in archetypal Sabbatian style. I read that his name can be decoded as Adam-Weishaupt or 'the first man to lead those who know'. He wasn't a leader in the sense that he was a subordinate, but he did lead those below him in a crusade of transforming human society that still continues today. The theme was confirmed as early as 1785 when a horseman courier called Lanz was reported to be struck by lightning and extensive Illuminati documents were found in his saddlebags. They made the link to Weishaupt and detailed the plan for world takeover. Current events with 'Covid' fascism have been in the making for a very long time. Jacob Frank was jailed for 13 years by the Catholic Inquisition after his arrest in 1760 and on his release he headed for Frankfurt, Germany, home city and headquarters of the House of Rothschild where the alliance was struck with Mayer Amschel Rothschild and Weishaupt. Rothschild arranged for Frank to be given the title of Baron and he became a wealthy nobleman with a big following of Jews in Germany, the Austro-Hungarian Empire and other European countries. Most of them would have believed he was on their side.

The name 'Illuminati' came from the Zohar which is a body of works in the Jewish mystical 'bible' called the Kabbalah. 'Zohar' is the foundation of Sabbatian-Frankist belief and in Hebrew 'Zohar' means 'splendour', 'radiance', 'illuminated', and so we have 'Illuminati'. They claim to be the 'Illuminated Ones' from their knowledge systematically hidden from the human population and passed on through generations of carefully-chosen initiates in the global secret society network or Cult. Hidden knowledge includes an awareness of the Cult agenda for the world and the nature of our collective reality that I will explore later. Cult 'illumination' is symbolised by the torch held by the Statue of Liberty which was gifted to New York by French Freemasons in Paris who knew exactly what it represents. 'Liberty' symbolises the goddess worshipped in

Babylon as Queen Semiramis or Ishtar. The significance of this will become clear. Notice again the ubiquitous theme of inversion with the Statue of 'Liberty' really symbolising mass control (Fig 7). A mirror-image statute stands on an island in the River Seine in Paris from where New York Liberty originated (Fig 8). A large replica of the Liberty flame stands on top of the Pont de l'Alma tunnel in Paris where Princess Diana died in a Cult ritual described in *The Biggest Secret*. Lucifer 'the light bringer' is related to all this (and much more as we'll see) and 'Lucifer' is a central figure in Sabbatian-Frankism and its associated Satanism. Sabbatians reject the Jewish Torah, or Pentateuch, the 'five books of Moses' in the Old Testament known as Genesis, Exodus, Leviticus, Numbers, and Deuteronomy which are claimed by Judaism and Christianity to have been dictated by 'God' to Moses on Mount Sinai. Sabbatians say these do not apply to them and they seek to replace them with the Zohar to absorb Judaism and its followers into their inversion which is an expression of a much greater global inversion. They want to delete all religions and force humanity to worship a one-world religion – Sabbatian Satanism that also includes worship of the Earth goddess. Satanic themes are being more and more introduced into mainstream society and while Christianity is currently the foremost target for destruction the others are planned to follow.



**Figure 7:** The Cult goddess of Babylon disguised as the Statue of Liberty holding the flame of Lucifer the 'light bringer'.



**Figure 8:** Liberty's mirror image in Paris where the New York version originated.

## **Marx brothers**

Rabbi Marvin Antelman connects the Illuminati to the Jacobins in *To Eliminate the Opiate* and Jacobins were the force behind the French Revolution. He links both to the Bund der Gerechten, or League of the Just, which was the network that inflicted communism/Marxism on the world. Antelman wrote:

The original inner circle of the Bund der Gerechten consisted of born Catholics, Protestants and Jews [Sabbatian-Frankist infiltrators], and those representatives of respective subdivisions formulated schemes for the ultimate destruction of their faiths. The heretical Catholics laid plans which they felt would take a century or more for the ultimate destruction of the church; the apostate Jews for the ultimate destruction of the Jewish religion.

Sabbatian-created communism connects into this anti-religion agenda in that communism does not allow for the free practice of religion. The Sabbatian 'Bund' became the International Communist Party and Communist League and in 1848 'Marxism' was born with the Communist Manifesto of Sabbatian assets Karl Marx and Friedrich Engels. It is absolutely no coincidence that Marxism, just a different name for fascist and other centrally-controlled tyrannies, is being imposed worldwide as a result of the 'Covid' hoax and nor that Marxist/fascist China was the place where the hoax originated. The reason for this will become very clear in the chapter 'Covid: The calculated catastrophe'. The so-called 'Woke' mentality has hijacked

traditional beliefs of the political left and replaced them with far-right make-believe 'social justice' better known as Marxism. Woke will, however, be swallowed by its own perceived 'revolution' which is really the work of billionaires and billionaire corporations feigning being 'Woke'. Marxism is being touted by Wokers as a replacement for 'capitalism' when we don't have 'capitalism'. We have cartelism in which the market is stitched up by the very Cult billionaires and corporations bankrolling Woke. Billionaires love Marxism which keeps the people in servitude while they control from the top. Terminally naïve Wokers think they are 'changing the world' when it's the Cult that is doing the changing and when they have played their vital part and become surplus to requirements they, too, will be targeted. The Illuminati-Jacobins were behind the period known as 'The Terror' in the French Revolution in 1793 and 1794 when Jacobin Maximillian de Robespierre and his Orwellian 'Committee of Public Safety' killed 17,000 'enemies of the Revolution' who had once been 'friends of the Revolution'. Karl Marx (1818-1883), whose Sabbatian creed of Marxism has cost the lives of at least 100 million people, is a hero once again to Wokers who have been systematically kept ignorant of real history by their 'education' programming. As a result they now promote a Sabbatian 'Marxist' abomination destined at some point to consume them. Rabbi Antelman, who spent decades researching the Sabbatian plot, said of the League of the Just and Karl Marx:

Contrary to popular opinion Karl Marx did not originate the Communist Manifesto. He was paid for his services by the League of the Just, which was known in its country of origin, Germany, as the Bund der Geächteten.

Antelman said the text attributed to Marx was the work of other people and Marx 'was only repeating what others already said'. Marx was 'a hired hack – lackey of the wealthy Illuminists'. Marx famously said that religion was the 'opium of the people' (part of the Sabbatian plan to demonise religion) and Antelman called his books, *To Eliminate the Opiate*. Marx was born Jewish, but his family converted to Christianity (Sabbatian modus operandi) and he

attacked Jews, not least in his book, *A World Without Jews*. In doing so he supported the Sabbatian plan to destroy traditional Jewishness and Judaism which we are clearly seeing today with the vindictive targeting of orthodox Jews by the Sabbatian government of Israel over 'Covid' laws. I don't follow any religion and it has done much damage to the world over centuries and acted as a perceptual straightjacket. Renegade Minds, however, are always asking *why* something is being done. It doesn't matter if they agree or disagree with what is happening – *why* is it happening is the question. The 'why?' can be answered with regard to religion in that religions create interacting communities of believers when the Cult wants to dismantle all discourse, unity and interaction (see 'Covid' lockdowns) and the ultimate goal is to delete all religions for a one-world religion of Cult Satanism worshipping their 'god' of which more later. We see the same 'why?' with gun control in America. I don't have guns and don't want them, but why is the Cult seeking to disarm the population at the same time that law enforcement agencies are armed to their molars and why has every tyrant in history sought to disarm people before launching the final takeover? They include Hitler, Stalin, Pol Pot and Mao who followed confiscation with violent seizing of power. You know it's a Cult agenda by the people who immediately race to the microphones to exploit dead people in multiple shootings. Ultra-Zionist Cult lackey Senator Chuck Schumer was straight on the case after ten people were killed in Boulder, Colorado in March, 2121. Simple rule ... if Schumer wants it the Cult wants it and the same with his ultra-Zionist mate the wild-eyed Senator Adam Schiff. At the same time they were calling for the disarmament of Americans, many of whom live a long way from a police response, Schumer, Schiff and the rest of these pampered clowns were sitting on Capitol Hill behind a razor-wired security fence protected by thousands of armed troops in addition to their own armed bodyguards. Mom and pop in an isolated home? They're just potential mass shooters.

## **Zion Mainframe**



Sabbatian-Frankists and most importantly the Rothschilds were behind the creation of 'Zionism', a political movement that demanded a Jewish homeland in Israel as promised by Sabbatai Zevi. The very symbol of Israel comes from the German meaning of the name Rothschild. Dynasty founder Mayer Amschel Rothschild changed the family name from Bauer to Rothschild, or 'Red-Shield' in German, in deference to the six-pointed 'Star of David' hexagram displayed on the family's home in Frankfurt. The symbol later appeared on the flag of Israel after the Rothschilds were centrally involved in its creation. Hexagrams are not a uniquely Jewish symbol and are widely used in occult ('hidden') networks often as a symbol for Saturn (see my other books for why). Neither are Zionism and Jewishness interchangeable. Zionism is a political movement and philosophy and not a 'race' or a people. Many Jews oppose Zionism and many non-Jews, including US President Joe Biden, call themselves Zionists as does Israel-centric Donald Trump. America's support for the Israel government is pretty much a gimme with ultra-Zionist billionaires and corporations providing fantastic and dominant funding for both political parties. Former Congresswoman Cynthia McKinney has told how she was approached immediately she ran for office to 'sign the pledge' to Israel and confirm that she would always vote in that country's best interests. All American politicians are approached in this way. Anyone who refuses will get no support or funding from the enormous and all-powerful Zionist lobby that includes organisations like mega-lobby group AIPAC, the American Israel Public Affairs Committee. Trump's biggest funder was ultra-Zionist casino and media billionaire Sheldon Adelson while major funders of the Democratic Party include ultra-Zionist George Soros and ultra-Zionist financial and media mogul, Haim Saban. Some may reel back at the suggestion that Soros is an Israel-firster (Sabbatian-controlled Israel-firster), but Renegade Minds watch the actions not the words and everywhere Soros donates his billions the Sabbatian agenda benefits. In the spirit of Sabbatian inversion Soros pledged \$1 billion for a new university network to promote 'liberal values and tackle intolerance'. He made the announcement during his annual speech

at the Cult-owned World Economic Forum in Davos, Switzerland, in January, 2020, after his 'harsh criticism' of 'authoritarian rulers' around the world. You can only laugh at such brazen mendacity. How *he* doesn't laugh is the mystery. Translated from the Orwellian 'liberal values and tackle intolerance' means teaching non-white people to hate white people and for white people to loathe themselves for being born white. The reason for that will become clear.

### **The 'Anti-Semitism' fraud**

Zionists support the Jewish homeland in the land of Palestine which has been the Sabbatian-Rothschild goal for so long, but not for the benefit of Jews. Sabbatians and their global Anti-Semitism Industry have skewed public and political opinion to equate opposing the violent extremes of Zionism to be a blanket attack and condemnation of all Jewish people. Sabbatians and their global Anti-Semitism Industry have skewed public and political opinion to equate opposing the violent extremes of Zionism to be a blanket attack and condemnation of all Jewish people. This is nothing more than a Sabbatian protection racket to stop legitimate investigation and exposure of their agendas and activities. The official definition of 'anti-Semitism' has more recently been expanded to include criticism of Zionism – a *political movement* – and this was done to further stop exposure of Sabbatian infiltrators who created Zionism as we know it today in the 19th century. Renegade Minds will talk about these subjects when they know the shit that will come their way. People must decide if they want to know the truth or just cower in the corner in fear of what others will say. Sabbatians have been trying to label me as 'anti-Semitic' since the 1990s as I have uncovered more and more about their background and agendas. Useless, gutless, fraudulent 'journalists' then just repeat the smears without question and on the day I was writing this section a pair of unquestioning repeaters called Ben Quinn and Archie Bland (how appropriate) outright called me an 'anti-Semite' in the establishment propaganda sheet, the London *Guardian*, with no supporting evidence. The

Sabbatian Anti-Semitism Industry said so and who are they to question that? They wouldn't dare. Ironically 'Semitic' refers to a group of languages in the Middle East that are almost entirely Arabic. 'Anti-Semitism' becomes 'anti-Arab' which if the consequences of this misunderstanding were not so grave would be hilarious. Don't bother telling Quinn and Bland. I don't want to confuse them, bless 'em. One reason I am dubbed 'anti-Semitic' is that I wrote in the 1990s that Jewish operatives (Sabbatians) were heavily involved in the Russian Revolution when Sabbatians overthrew the Romanov dynasty. This apparently made me 'anti-Semitic'. Oh, really? Here is a section from *The Trigger*:

British journalist Robert Wilton confirmed these themes in his 1920 book *The Last Days of the Romanovs* when he studied official documents from the Russian government to identify the members of the Bolshevik ruling elite between 1917 and 1919. The Central Committee included 41 Jews among 62 members; the Council of the People's Commissars had 17 Jews out of 22 members; and 458 of the 556 most important Bolshevik positions between 1918 and 1919 were occupied by Jewish people. Only 17 were Russian. Then there were the 23 Jews among the 36 members of the vicious Cheka Soviet secret police established in 1917 who would soon appear all across the country.

Professor Robert Service of Oxford University, an expert on 20th century Russian history, found evidence that ['Jewish'] Leon Trotsky had sought to make sure that Jews were enrolled in the Red Army and were disproportionately represented in the Soviet civil bureaucracy that included the Cheka which performed mass arrests, imprisonment and executions of 'enemies of the people'. A US State Department Decimal File (861.00/5339) dated November 13th, 1918, names [Rothschild banking agent in America] Jacob Schiff and a list of ultra-Zionists as funders of the Russian Revolution leading to claims of a 'Jewish plot', but the key point missed by all is they were not 'Jews' – they were Sabbatian-Frankists.

Britain's Winston Churchill made the same error by mistake or otherwise. He wrote in a 1920 edition of the *Illustrated Sunday Herald* that those behind the Russian revolution were part of a 'worldwide conspiracy for the overthrow of civilisation and for the reconstitution of society on the basis of arrested development, of envious malevolence, and impossible equality' (see 'Woke' today because that has been created by the same network). Churchill said there was no need to exaggerate the part played in the creation of Bolshevism and in the actual bringing about of the Russian

Revolution 'by these international and for the most part atheistical Jews' ['atheistical Jews' = Sabbatians]. Churchill said it is certainly a very great one and probably outweighs all others: 'With the notable exception of Lenin, the majority of the leading figures are Jews.' He went on to describe, knowingly or not, the Sabbatian modus operandi of placing puppet leaders nominally in power while they control from the background:

Moreover, the principal inspiration and driving power comes from the Jewish leaders. Thus Tchitcherin, a pure Russian, is eclipsed by his nominal subordinate, Litvinoff, and the influence of Russians like Bukharin or Lunacharski cannot be compared with the power of Trotsky, or of Zinovieff, the Dictator of the Red Citadel (Petrograd), or of Krassin or Radek – all Jews. In the Soviet institutions the predominance of Jews is even more astonishing. And the prominent, if not indeed the principal, part in the system of terrorism applied by the Extraordinary Commissions for Combatting Counter-Revolution has been taken by Jews, and in some notable cases by Jewesses.

What I said about seriously disproportionate involvement in the Russian Revolution by Jewish 'revolutionaries' (Sabbatians) is provable fact, but truth is no defence against the Sabbatian Anti-Semitism Industry, its repeater parrots like Quinn and Bland, and the now breathtaking network of so-called 'Woke' 'anti-hate' groups with interlocking leaderships and funding which have the role of discrediting and silencing anyone who gets too close to exposing the Sabbatians. We have seen 'truth is no defence' confirmed in legal judgements with the Saskatchewan Human Rights Commission in Canada decreeing this: 'Truthful statements can be presented in a manner that would meet the definition of hate speech, and not all truthful statements must be free from restriction.' Most 'anti-hate' activists, who are themselves consumed by hatred, are too stupid and ignorant of the world to know how they are being used. They are far too far up their own virtue-signalling arses and it's far too dark for them to see anything.

## **The 'revolution' game**

The background and methods of the 'Russian' Revolution are straight from the Sabbatian playbook seen in the French Revolution

and endless others around the world that appear to start as a revolution of the people against tyrannical rule and end up with a regime change to more tyrannical rule overtly or covertly. Wars, terror attacks and regime overthrows follow the Sabbatian cult through history with its agents creating them as Problem-Reaction-Solutions to remove opposition on the road to world domination. Sabbatian dots connect the Rothschilds with the Illuminati, Jacobins of the French Revolution, the 'Bund' or League of the Just, the International Communist Party, Communist League and the Communist Manifesto of Karl Marx and Friedrich Engels that would lead to the Rothschild-funded Russian Revolution. The sequence comes under the heading of 'creative destruction' when you advance to your global goal by continually destroying the status quo to install a new status quo which you then also destroy. The two world wars come to mind. With each new status quo you move closer to your planned outcome. Wars and mass murder are to Sabbatians a collective blood sacrifice ritual. They are obsessed with death for many reasons and one is that death is an inversion of life. Satanists and Sabbatians are obsessed with death and often target churches and churchyards for their rituals. Inversion-obsessed Sabbatians explain the use of inverted symbolism including the *inverted* pentagram and *inverted* cross. The inversion of the cross has been related to targeting Christianity, but the cross was a religious symbol long before Christianity and its inversion is a statement about the Sabbatian mentality and goals more than any single religion.

Sabbatians operating in Germany were behind the rise of the occult-obsessed Nazis and the subsequent Jewish exodus from Germany and Europe to Palestine and the United States after World War Two. The Rothschild dynasty was at the forefront of this both as political manipulators and by funding the operation. Why would Sabbatians help to orchestrate the horrors inflicted on Jews by the Nazis and by Stalin after they organised the Russian Revolution? Sabbatians hate Jews and their religion, that's why. They pose as Jews and secure positions of control within Jewish society and play the 'anti-Semitism' card to protect themselves from exposure

through a global network of organisations answering to the Sabbatian-created-and-controlled globe-spanning intelligence network that involves a stunning web of military-intelligence operatives and operations for a tiny country of just nine million. Among them are Jewish assets who are not Sabbatians but have been convinced by them that what they are doing is for the good of Israel and the Jewish community to protect them from what they have been programmed since childhood to believe is a Jew-hating hostile world. The Jewish community is just a highly convenient cover to hide the true nature of Sabbatians. Anyone getting close to exposing their game is accused by Sabbatian place-people and gofers of 'anti-Semitism' and claiming that all Jews are part of a plot to take over the world. I am not saying that. I am saying that Sabbatians – the *real* Jew-haters – have infiltrated the Jewish community to use them both as a cover and an 'anti-Semitic' defence against exposure. Thus we have the Anti-Semitism Industry targeted researchers in this way and most Jewish people think this is justified and genuine. They don't know that their 'Jewish' leaders and institutions of state, intelligence and military are not controlled by Jews at all, but cultists and stooges of Sabbatian-Frankism. I once added my name to a pro-Jewish freedom petition online and the next time I looked my name was gone and text had been added to the petition blurb to attack me as an 'anti-Semite' such is the scale of perceptual programming.

## **Moving on America**

I tell the story in *The Trigger* and a chapter called 'Atlantic Crossing' how particularly after Israel was established the Sabbatians moved in on the United States and eventually grasped control of government administration, the political system via both Democrats and Republicans, the intelligence community like the CIA and National Security Agency (NSA), the Pentagon and mass media. Through this seriously compartmentalised network Sabbatians and their operatives in Mossad, Israeli Defense Forces (IDF) and US agencies pulled off 9/11 and blamed it on 19 'Al-Qaeda hijackers' dominated by men from, or connected to, Sabbatian-ruled Saudi

Arabia. The '19' were not even on the planes let alone flew those big passenger jets into buildings while being largely incompetent at piloting one-engine light aircraft. 'Hijacker' Hani Hanjour who is said to have flown American Airlines Flight 77 into the Pentagon with a turn and manoeuvre most professional pilots said they would have struggled to do was banned from renting a small plane by instructors at the Freeway Airport in Bowie, Maryland, just *six weeks* earlier on the grounds that he was an incompetent pilot. The Jewish population of the world is just 0.2 percent with even that almost entirely concentrated in Israel (75 percent Jewish) and the United States (around two percent). This two percent and globally 0.2 percent refers to *Jewish* people and not Sabbatian interlopers who are a fraction of that fraction. What a sobering thought when you think of the fantastic influence on world affairs of tiny Israel and that the Project for the New America Century (PNAC) which laid out the blueprint in September, 2000, for America's war on terror and regime change wars in Iraq, Libya and Syria was founded and dominated by Sabbatians known as 'Neocons'. The document conceded that this plan would not be supported politically or publicly without a major attack on American soil and a Problem-Reaction-Solution excuse to send troops to war across the Middle East. Sabbatian Neocons said:

... [The] process of transformation ... [war and regime change] ... is likely to be a long one, absent some catastrophic and catalysing event – like a new Pearl Harbor.

Four months later many of those who produced that document came to power with their inane puppet George Bush from the long-time Sabbatian Bush family. They included Sabbatian Dick Cheney who was officially vice-president, but really de-facto president for the entirety of the 'Bush' government. Nine months after the 'Bush' inauguration came what Bush called at the time 'the Pearl Harbor of the 21st century' and with typical Sabbatian timing and symbolism 2001 was the 60th anniversary of the attack in 1941 by the Japanese Air Force on Pearl Harbor, Hawaii, which allowed President Franklin Delano Roosevelt to take the United States into a Sabbatian-

instigated Second World War that he said in his election campaign that he never would. The evidence is overwhelming that Roosevelt and his military and intelligence networks knew the attack was coming and did nothing to stop it, but they did make sure that America's most essential naval ships were not in Hawaii at the time. Three thousand Americans died in the Pearl Harbor attacks as they did on September 11th. By the 9/11 year of 2001 Sabbatians had widely infiltrated the US government, military and intelligence operations and used their compartmentalised assets to pull off the 'Al-Qaeda' attacks. If you read *The Trigger* it will blow your mind to see the utterly staggering concentration of 'Jewish' operatives (Sabbatian infiltrators) in essential positions of political, security, legal, law enforcement, financial and business power before, during, and after the attacks to make them happen, carry them out, and then cover their tracks – and I do mean *staggering* when you think of that 0.2 percent of the world population and two percent of Americans which are Jewish while Sabbatian infiltrators are a fraction of that. A central foundation of the 9/11 conspiracy was the hijacking of government, military, Air Force and intelligence computer systems in real time through 'back-door' access made possible by Israeli (Sabbatian) 'cyber security' software. Sabbatian-controlled Israel is on the way to rivalling Silicon Valley for domination of cyberspace and is becoming the dominant force in cyber-security which gives them access to entire computer systems and their passcodes across the world. Then add to this that Zionists head (officially) Silicon Valley giants like Google (Larry Page and Sergey Brin), Google-owned YouTube (Susan Wojcicki), Facebook (Mark Zuckerberg and Sheryl Sandberg), and Apple (Chairman Arthur D. Levinson), and that ultra-Zionist hedge fund billionaire Paul Singer has a \$1 billion stake in Twitter which is only nominally headed by 'CEO' pothead Jack Dorsey. As cable news host Tucker Carlson said of Dorsey: 'There used to be debate in the medical community whether dropping a ton of acid had permanent effects and I think that debate has now ended.' Carlson made the comment after Dorsey told a hearing on Capitol Hill (if you cut through his bullshit) that he



believed in free speech so long as he got to decide what you can hear and see. These 'big names' of Silicon Valley are only front men and women for the Global Cult, not least the Sabbatians, who are the true controllers of these corporations. Does anyone still wonder why these same people and companies have been ferociously censoring and banning people (like me) for exposing any aspect of the Cult agenda and especially the truth about the 'Covid' hoax which Sabbatians have orchestrated?

The Jeffrey Epstein paedophile ring was a Sabbatian operation. He was officially 'Jewish' but he was a Sabbatian and women abused by the ring have told me about the high number of 'Jewish' people involved. The Epstein horror has Sabbatian written all over it and matches perfectly their modus operandi and obsession with sex and ritual. Epstein was running a Sabbatian blackmail ring in which famous people with political and other influence were provided with young girls for sex while everything was being filmed and recorded on hidden cameras and microphones at his New York house, Caribbean island and other properties. Epstein survivors have described this surveillance system to me and some have gone public. Once the famous politician or other figure knew he or she was on video they tended to do whatever they were told. Here we go again ...when you've got them by the balls their hearts and minds will follow. Sabbatians use this blackmail technique on a wide scale across the world to entrap politicians and others they need to act as demanded. Epstein's private plane, the infamous 'Lolita Express', had many well-known passengers including Bill Clinton while Bill Gates has flown on an Epstein plane and met with him four years after Epstein had been jailed for paedophilia. They subsequently met many times at Epstein's home in New York according to a witness who was there. Epstein's infamous side-kick was Ghislaine Maxwell, daughter of Mossad agent and ultra-Zionist mega-crooked British businessman, Bob Maxwell, who at one time owned the *Daily Mirror* newspaper. Maxwell was murdered at sea on his boat in 1991 by Sabbatian-controlled Mossad when he became a liability with his

business empire collapsing as a former Mossad operative has confirmed (see *The Trigger*).

### **Money, money, money, funny money ...**

Before I come to the Sabbatian connection with the last three US presidents I will lay out the crucial importance to Sabbatians of controlling banking and finance. Sabbatian Mayer Amschel Rothschild set out to dominate this arena in his family's quest for total global control. What is freedom? It is, in effect, choice. The more choices you have the freer you are and the fewer your choices the more you are enslaved. In the global structure created over centuries by Sabbatians the biggest decider and restrictor of choice is ... money. Across the world if you ask people what they would like to do with their lives and why they are not doing that they will reply 'I don't have the money'. This is the idea. A global elite of multi-billionaires are described as 'greedy' and that is true on one level; but control of money – who has it and who doesn't – is not primarily about greed. It's about control. Sabbatians have seized ever more control of finance and sucked the wealth of the world out of the hands of the population. We talk now, after all, about the 'One-percent' and even then the wealthiest are a lot fewer even than that. This has been made possible by a money scam so outrageous and so vast it could rightly be called the scam of scams founded on creating 'money' out of nothing and 'loaning' that with interest to the population. Money out of nothing is called 'credit'. Sabbatians have asserted control over governments and banking ever more completely through the centuries and secured financial laws that allow banks to lend hugely more than they have on deposit in a confidence trick known as fractional reserve lending. Imagine if you could lend money that doesn't exist and charge the recipient interest for doing so. You would end up in jail. Bankers by contrast end up in mansions, private jets, Malibu and Monaco.

Banks are only required to keep a fraction of their deposits and wealth in their vaults and they are allowed to lend 'money' they don't have called 'credit'. Go into a bank for a loan and if you succeed

the banker will not move any real wealth into your account. They will type into your account the amount of the agreed 'loan' – say £100,000. This is not wealth that really exists; it is non-existent, fresh-air, created-out-of-nothing 'credit' which has never, does not, and will never exist except in theory. Credit is backed by nothing except wind and only has buying power because people think that it has buying power and accept it in return for property, goods and services. I have described this situation as like those cartoon characters you see chasing each other and when they run over the edge of a cliff they keep running forward on fresh air until one of them looks down, realises what's happened, and they all crash into the ravine. The whole foundation of the Sabbatian financial system is to stop people looking down except for periodic moments when they want to crash the system (as in 2008 and 2020 ongoing) and reap the rewards from all the property, businesses and wealth their borrowers had signed over as 'collateral' in return for a 'loan' of fresh air. Most people think that money is somehow created by governments when it comes into existence from the start as a debt through banks 'lending' illusory money called credit. Yes, the very currency of exchange is a *debt* from day one issued as an interest-bearing loan. Why don't governments create money interest-free and lend it to their people interest-free? Governments are controlled by Sabbatians and the financial system is controlled by Sabbatians for whom interest-free money would be a nightmare come true. Sabbatians underpin their financial domination through their global network of central banks, including the privately-owned US Federal Reserve and Britain's Bank of England, and this is orchestrated by a privately-owned central bank coordination body called the Bank for International Settlements in Basle, Switzerland, created by the usual suspects including the Rockefellers and Rothschilds. Central bank chiefs don't answer to governments or the people. They answer to the Bank for International Settlements or, in other words, the Global Cult which is dominated today by Sabbatians.

## **Built-in disaster**

There are so many constituent scams within the overall banking scam. When you take out a loan of thin-air credit only the amount of that loan is theoretically brought into circulation to add to the amount in circulation; but you are paying back the principle plus interest. The additional interest is not created and this means that with every 'loan' there is a shortfall in the money in circulation between what is borrowed and what has to be paid back. There is never even close to enough money in circulation to repay all outstanding public and private debt including interest. Coldly weaved in the very fabric of the system is the certainty that some will lose their homes, businesses and possessions to the banking 'lender'. This is less obvious in times of 'boom' when the amount of money in circulation (and the debt) is expanding through more people wanting and getting loans. When a downturn comes and the money supply contracts it becomes painfully obvious that there is not enough money to service all debt and interest. This is less obvious in times of 'boom' when the amount of money in circulation (and the debt) is expanding through more people wanting and getting loans. When a downturn comes and the money supply contracts and it becomes painfully obvious – as in 2008 and currently – that there is not enough money to service all debt and interest. Sabbatian banksters have been leading the human population through a calculated series of booms (more debt incurred) and busts (when the debt can't be repaid and the banks get the debtor's tangible wealth in exchange for non-existent 'credit'). With each 'bust' Sabbatian bankers have absorbed more of the world's tangible wealth and we end up with the One-percent. Governments are in bankruptcy levels of debt to the same system and are therefore owned by a system they do not control. The Federal Reserve, 'America's central bank', is privately-owned and American presidents only nominally appoint its chairman or woman to maintain the illusion that it's an arm of government. It's not. The 'Fed' is a cartel of private banks which handed billions to its associates and friends after the crash of 2008 and has been Sabbatian-controlled since it was manipulated into being in 1913 through the covert trickery of Rothschild banking agents Jacob Schiff and Paul

Warburg, and the Sabbatian Rockefeller family. Somehow from a Jewish population of two-percent and globally 0.2 percent (Sabbatian interlopers remember are far smaller) ultra-Zionists headed the Federal Reserve for 31 years between 1987 and 2018 in the form of Alan Greenspan, Bernard Bernanke and Janet Yellen (now Biden's Treasury Secretary) with Yellen's deputy chairman a Israeli-American dual citizen and ultra-Zionist Stanley Fischer, a former governor of the Bank of Israel. Ultra-Zionist Fed chiefs spanned the presidencies of Ronald Reagan ('Republican'), Father George Bush ('Republican'), Bill Clinton ('Democrat'), Boy George Bush ('Republican') and Barack Obama ('Democrat'). We should really add the pre-Greenspan chairman, Paul Adolph Volcker, 'appointed' by Jimmy Carter ('Democrat') who ran the Fed between 1979 and 1987 during the Carter and Reagan administrations before Greenspan took over. Volcker was a long-time associate and business partner of the Rothschilds. No matter what the 'party' officially in power the United States economy was directed by the same force. Here are members of the Obama, Trump and Biden administrations and see if you can make out a common theme.

### **Barack Obama ('Democrat')**

Ultra-Zionists Robert Rubin, Larry Summers, and Timothy Geithner ran the US Treasury in the Clinton administration and two of them reappeared with Obama. Ultra-Zionist Fed chairman Alan Greenspan had manipulated the crash of 2008 through deregulation and jumped ship just before the disaster to make way for ultra-Zionist Bernard Bernanke to hand out trillions to Sabbatian 'too big to fail' banks and businesses, including the ubiquitous ultra-Zionist Goldman Sachs which has an ongoing revolving door operation between itself and major financial positions in government worldwide. Obama inherited the fallout of the crash when he took office in January, 2009, and fortunately he had the support of his ultra-Zionist White House Chief of Staff Rahm Emmanuel, son of a terrorist who helped to bomb Israel into being in 1948, and his ultra-Zionist senior adviser David Axelrod, chief strategist in Obama's two

successful presidential campaigns. Emmanuel, later mayor of Chicago and former senior fundraiser and strategist for Bill Clinton, is an example of the Sabbatian policy after Israel was established of migrating insider families to America so their children would be born American citizens. 'Obama' chose this financial team throughout his administration to respond to the Sabbatian-instigated crisis:

Timothy Geithner (ultra-Zionist) Treasury Secretary; Jacob J. Lew, Treasury Secretary; Larry Summers (ultra-Zionist), director of the White House National Economic Council; Paul Adolph Volcker (Rothschild business partner), chairman of the Economic Recovery Advisory Board; Peter Orszag (ultra-Zionist), director of the Office of Management and Budget overseeing all government spending; Penny Pritzker (ultra-Zionist), Commerce Secretary; Jared Bernstein (ultra-Zionist), chief economist and economic policy adviser to Vice President Joe Biden; Mary Schapiro (ultra-Zionist), chair of the Securities and Exchange Commission (SEC); Gary Gensler (ultra-Zionist), chairman of the Commodity Futures Trading Commission (CFTC); Sheila Bair (ultra-Zionist), chair of the Federal Deposit Insurance Corporation (FDIC); Karen Mills (ultra-Zionist), head of the Small Business Administration (SBA); Kenneth Feinberg (ultra-Zionist), Special Master for Executive [bail-out] Compensation. Feinberg would be appointed to oversee compensation (with strings) to 9/11 victims and families in a campaign to stop them having their day in court to question the official story. At the same time ultra-Zionist Bernard Bernanke was chairman of the Federal Reserve and these are only some of the ultra-Zionists with allegiance to Sabbatian-controlled Israel in the Obama government. Obama's biggest corporate donor was ultra-Zionist Goldman Sachs which had employed many in his administration.

### **Donald Trump ('Republican')**

Trump claimed to be an outsider (he wasn't) who had come to 'drain the swamp'. He embarked on this goal by immediately appointing ultra-Zionist Steve Mnuchin, a Goldman Sachs employee for 17

years, as his Treasury Secretary. Others included Gary Cohn (ultra-Zionist), chief operating officer of Goldman Sachs, his first Director of the National Economic Council and chief economic adviser, who was later replaced by Larry Kudlow (ultra-Zionist). Trump's senior adviser throughout his four years in the White House was his sinister son-in-law Jared Kushner, a life-long friend of Israel Prime Minister Benjamin Netanyahu. Kushner is the son of a convicted crook who was pardoned by Trump in his last days in office. Other ultra-Zionists in the Trump administration included: Stephen Miller, Senior Policy Adviser; Avrahm Berkowitz, Deputy Adviser to Trump and his Senior Adviser Jared Kushner; Ivanka Trump, Adviser to the President, who converted to Judaism when she married Jared Kushner; David Friedman, Trump lawyer and Ambassador to Israel; Jason Greenblatt, Trump Organization executive vice president and chief legal officer, who was made Special Representative for International Negotiations and the Israeli-Palestinian Conflict; Rod Rosenstein, Deputy Attorney General; Elliot Abrams, Special Representative for Venezuela, then Iran; John Eisenberg, National Security Council Legal Adviser and Deputy Council to the President for National Security Affairs; Anne Neuberger, Deputy National Manager, National Security Agency; Ezra Cohen-Watnick, Acting Under Secretary of Defense for Intelligence; Elan Carr, Special Envoy to monitor and combat anti-Semitism; Len Khodorkovsky, Deputy Special Envoy to monitor and combat anti-Semitism; Reed Cordish, Assistant to the President, Intragovernmental and Technology Initiatives. Trump Vice President Mike Pence and Secretary of State Mike Pompeo, both Christian Zionists, were also vehement supporters of Israel and its goals and ambitions.

Donald 'free-speech believer' Trump pardoned a number of financial and violent criminals while ignoring calls to pardon Julian Assange and Edward Snowden whose crimes are revealing highly relevant information about government manipulation and corruption and the widespread illegal surveillance of the American people by US 'security' agencies. It's so good to know that Trump is on the side of freedom and justice and not mega-criminals with

allegiance to Sabbatian-controlled Israel. These included a pardon for Israeli spy Jonathan Pollard who was jailed for life in 1987 under the Espionage Act. Aviem Sella, the Mossad agent who recruited Pollard, was also pardoned by Trump while Assange sat in jail and Snowden remained in exile in Russia. Sella had 'fled' (was helped to escape) to Israel in 1987 and was never extradited despite being charged under the Espionage Act. A Trump White House statement said that Sella's clemency had been 'supported by Benjamin Netanyahu, Ron Dermer, Israel's US Ambassador, David Friedman, US Ambassador to Israel and Miriam Adelson, wife of leading Trump donor Sheldon Adelson who died shortly before. Other friends of Jared Kushner were pardoned along with Sholom Weiss who was believed to be serving the longest-ever white-collar prison sentence of more than 800 years in 2000. The sentence was commuted of Ponzi-schemer Eliyahu Weinstein who defrauded Jews and others out of \$200 million. I did mention that Assange and Snowden were ignored, right? Trump gave Sabbatians almost everything they asked for in military and political support, moving the US Embassy from Tel Aviv to Jerusalem with its critical symbolic and literal implications for Palestinian statehood, and the 'deal of the Century' designed by Jared Kushner and David Friedman which gave the Sabbatian Israeli government the green light to substantially expand its already widespread program of building illegal Jewish-only settlements in the occupied land of the West Bank. This made a two-state 'solution' impossible by seizing all the land of a potential Palestinian homeland and that had been the plan since 1948 and then 1967 when the Arab-controlled Gaza Strip, West Bank, Sinai Peninsula and Syrian Golan Heights were occupied by Israel. All the talks about talks and road maps and delays have been buying time until the West Bank was physically occupied by Israeli real estate. Trump would have to be a monumentally ill-informed idiot not to see that this was the plan he was helping to complete. The Trump administration was in so many ways the Kushner administration which means the Netanyahu administration which means the Sabbatian administration. I understand why many opposing Cult fascism in all its forms gravitated to Trump, but he



was a crucial part of the Sabbatian plan and I will deal with this in the next chapter.

## **Joe Biden ('Democrat')**

A barely cognitive Joe Biden took over the presidency in January, 2021, along with his fellow empty shell, Vice-President Kamala Harris, as the latest Sabbatian gofers to enter the White House. Names on the door may have changed and the 'party' – the force behind them remained the same as Zionists were appointed to a stream of pivotal areas relating to Sabbatian plans and policy. They included: Janet Yellen, Treasury Secretary, former head of the Federal Reserve, and still another ultra-Zionist running the US Treasury after Mnuchin (Trump), Lew and Geithner (Obama), and Summers and Rubin (Clinton); Anthony Blinken, Secretary of State; Wendy Sherman, Deputy Secretary of State (so that's 'Biden's' Sabbatian foreign policy sorted); Jeff Zients, White House coronavirus coordinator; Rochelle Walensky, head of the Centers for Disease Control; Rachel Levine, transgender deputy health secretary (that's 'Covid' hoax policy under control); Merrick Garland, Attorney General; Alejandro Mayorkas, Secretary of Homeland Security; Cass Sunstein, Homeland Security with responsibility for new immigration laws; Avril Haines, Director of National Intelligence; Anne Neuberger, National Security Agency cybersecurity director (note, cybersecurity); David Cohen, CIA Deputy Director; Ronald Klain, Biden's Chief of Staff (see Rahm Emanuel); Eric Lander, a 'leading geneticist', Office of Science and Technology Policy director (see Smart Grid, synthetic biology agenda); Jessica Rosenworcel, acting head of the Federal Communications Commission (FCC) which controls Smart Grid technology policy and electromagnetic communication systems including 5G. How can it be that so many pivotal positions are held by two-percent of the American population and 0.2 percent of the world population administration after administration no matter who is the president and what is the party? It's a coincidence? Of course it's not and this is why Sabbatians have built their colossal global web of interlocking 'anti-

hate' hate groups to condemn anyone who asks these glaring questions as an 'anti-Semite'. The way that Jewish people horrifically abused in Sabbatian-backed Nazi Germany are exploited to this end is stomach-turning and disgusting beyond words.

## **Political fusion**

Sabbatian manipulation has reversed the roles of Republicans and Democrats and the same has happened in Britain with the Conservative and Labour Parties. Republicans and Conservatives were always labelled the 'right' and Democrats and Labour the 'left', but look at the policy positions now and the Democrat-Labour 'left' has moved further to the 'right' than Republicans and Conservatives under the banner of 'Woke', the Cult-created far-right tyranny. Where once the Democrat-Labour 'left' defended free speech and human rights they now seek to delete them and as I said earlier despite the 'Covid' fascism of the Jackboot Johnson Conservative government in the UK the Labour Party of leader Keir Starmer demanded even more extreme measures. The Labour Party has been very publicly absorbed by Sabbatians after a political and media onslaught against the previous leader, the weak and inept Jeremy Corbyn, over made-up allegations of 'anti-Semitism' both by him and his party. The plan was clear with this 'anti-Semite' propaganda and what was required in response was a swift and decisive 'fuck off' from Corbyn and a statement to expose the Anti-Semitism Industry (Sabbatian) attempt to silence Labour criticism of the Israeli government (Sabbatians) and purge the party of all dissent against the extremes of ultra-Zionism (Sabbatians). Instead Corbyn and his party fell to their knees and appeased the abusers which, by definition, is impossible. Appeasing one demand leads only to a new demand to be appeased until takeover is complete. Like I say – 'fuck off' would have been a much more effective policy and I have used it myself with great effect over the years when Sabbatians are on my case which is most of the time. I consider that fact a great compliment, by the way. The outcome of the Labour Party capitulation is that we now have a Sabbatian-controlled

Conservative Party 'opposed' by a Sabbatian-controlled Labour Party in a one-party Sabbatian state that hurtles towards the extremes of tyranny (the Sabbatian cult agenda). In America the situation is the same. Labour's Keir Starmer spends his days on his knees with his tongue out pointing to Tel Aviv, or I guess now Jerusalem, while Boris Johnson has an 'anti-Semitism czar' in the form of former Labour MP John Mann who keeps Starmer company on his prayer mat.

Sabbatian influence can be seen in Jewish members of the Labour Party who have been ejected for criticism of Israel including those from families that suffered in Nazi Germany. Sabbatians despise real Jewish people and target them even more harshly because it is so much more difficult to dub them 'anti-Semitic' although in their desperation they do try.

## CHAPTER THREE

### **The Pushbacker sting**

*Until you realize how easy it is for your mind to be manipulated, you remain the puppet of someone else's game*

Evita Ochel

I will use the presidencies of Trump and Biden to show how the manipulation of the one-party state plays out behind the illusion of political choice across the world. No two presidencies could – on the face of it – be more different and apparently at odds in terms of direction and policy.

A Renegade Mind sees beyond the obvious and focuses on outcomes and consequences and not image, words and waffle. The Cult embarked on a campaign to divide America between those who blindly support its agenda (the mentality known as 'Woke') and those who are pushing back on where the Cult and its Sabbatians want to go. This presents infinite possibilities for dividing and ruling the population by setting them at war with each other and allows a perceptual ring fence of demonisation to encircle the Pushbackers in a modern version of the Little Big Horn in 1876 when American cavalry led by Lieutenant Colonel George Custer were drawn into a trap, surrounded and killed by Native American tribes defending their land of thousands of years from being seized by the government. In this modern version the roles are reversed and it's those defending themselves from the Sabbatian government who are surrounded and the government that's seeking to destroy them. This trap was set years ago and to explain how we must return to 2016

and the emergence of Donald Trump as a candidate to be President of the United States. He set out to overcome the best part of 20 other candidates in the Republican Party before and during the primaries and was not considered by many in those early stages to have a prayer of living in the White House. The Republican Party was said to have great reservations about Trump and yet somehow he won the nomination. When you know how American politics works – politics in general – there is no way that Trump could have become the party's candidate unless the Sabbatian-controlled 'Neocons' that run the Republican Party wanted that to happen. We saw the proof in emails and documents made public by WikiLeaks that the Democratic Party hierarchy, or Democons, systematically undermined the campaign of Bernie Sanders to make sure that Sabbatian gofer Hillary Clinton won the nomination to be their presidential candidate. If the Democons could do that then the Neocons in the Republican Party could have derailed Trump in the same way. But they didn't and at that stage I began to conclude that Trump could well be the one chosen to be president. If that was the case the 'why' was pretty clear to see – the goal of dividing America between Cult agenda-supporting Wokers and Pushbackers who gravitated to Trump because he was telling them what they wanted to hear. His constituency of support had been increasingly ignored and voiceless for decades and profoundly through the eight years of Sabbatian puppet Barack Obama. Now here was someone speaking their language of pulling back from the incessant globalisation of political and economic power, the exporting of American jobs to China and elsewhere by 'American' (Sabbatian) corporations, the deletion of free speech, and the mass immigration policies that had further devastated job opportunities for the urban working class of all races and the once American heartlands of the Midwest.

### **Beware the forked tongue**

Those people collectively sighed with relief that at last a political leader was apparently on their side, but another trait of the Renegade Mind is that you look even harder at people telling you

what you want to hear than those who are telling you otherwise. Obviously as I said earlier people wish what they want to hear to be true and genuine and they are much more likely to believe that than someone saying what they don't want to hear and don't want to be true. Sales people are taught to be skilled in eliciting by calculated questioning what their customers want to hear and repeating that back to them as their own opinion to get their targets to like and trust them. Assets of the Cult are also sales people in the sense of selling perception. To read Cult manipulation you have to play the long and expanded game and not fall for the Vaudeville show of party politics. Both American parties are vehicles for the Cult and they exploit them in different ways depending on what the agenda requires at that moment. Trump and the Republicans were used to be the focus of dividing America and isolating Pushbackers to open the way for a Biden presidency to become the most extreme in American history by advancing the full-blown Woke (Cult) agenda with the aim of destroying and silencing Pushbackers now labelled Nazi Trump supporters and white supremacists.

Sabbatians wanted Trump in office for the reasons described by ultra-Zionist Saul Alinsky (1909-1972) who was promoting the Woke philosophy through 'community organising' long before anyone had heard of it. In those days it still went by its traditional name of Marxism. The reason for the manipulated Trump phenomenon was laid out in Alinsky's 1971 book, *Rules for Radicals*, which was his blueprint for overthrowing democratic and other regimes and replacing them with Sabbatian Marxism. Not surprisingly his to-do list was evident in the Sabbatian French and Russian 'Revolutions' and that in China which will become very relevant in the next chapter about the 'Covid' hoax. Among Alinsky's followers have been the deeply corrupt Barack Obama, House Speaker Nancy Pelosi and Hillary Clinton who described him as a 'hero'. All three are Sabbatian stooges with Pelosi personifying the arrogant corrupt idiocy that so widely fronts up for the Cult inner core. Predictably as a Sabbatian advocate of the 'light-bringer' Alinsky features Lucifer on the dedication page of his book as the original radical who gained

his own kingdom ('Earth' as we shall see). One of Alinsky's golden radical rules was to pick an individual and focus all attention, hatred and blame on them and not to target faceless bureaucracies and corporations. *Rules for Radicals* is really a Sabbatian handbook with its contents repeatedly employed all over the world for centuries and why wouldn't Sabbatians bring to power their designer-villain to be used as the individual on which all attention, hatred and blame was bestowed? This is what they did and the only question for me is how much Trump knew that and how much he was manipulated. A bit of both, I suspect. This was Alinsky's Trump technique from a man who died in 1972. The technique has spanned history:

Pick the target, freeze it, personalize it, polarize it. Don't try to attack abstract corporations or bureaucracies. Identify a responsible individual. Ignore attempts to shift or spread the blame.

From the moment Trump came to illusory power everything was about him. It wasn't about Republican policy or opinion, but all about Trump. Everything he did was presented in negative, derogatory and abusive terms by the Sabbatian-dominated media led by Cult operations such as CNN, MSNBC, *The New York Times* and the Jeff Bezos-owned *Washington Post* – 'Pick the target, freeze it, personalize it, polarize it.' Trump was turned into a demon to be vilified by those who hated him and a demi-god loved by those who worshipped him. This, in turn, had his supporters, too, presented as equally demonic in preparation for the punchline later down the line when Biden was about to take office. It was here's a Trump, there's a Trump, everywhere a Trump, Trump. Virtually every news story or happening was filtered through the lens of 'The Donald'. You loved him or hated him and which one you chose was said to define you as Satan's spawn or a paragon of virtue. Even supporting some Trump policies or statements and not others was enough for an assault on your character. No shades of grey were or are allowed. Everything is black and white (literally and figuratively). A Californian I knew had her head utterly scrambled by her hatred for Trump while telling people they should love each other. She was so totally consumed by

Trump Derangement Syndrome as it became to be known that this glaring contradiction would never have occurred to her. By definition anyone who criticised Trump or praised his opponents was a hero and this lady described Joe Biden as 'a kind, honest gentleman' when he's a provable liar, mega-crook and vicious piece of work to boot. Sabbatians had indeed divided America using Trump as the fall-guy and all along the clock was ticking on the consequences for his supporters.

### **In hock to his masters**

Trump gave Sabbatians via Israel almost everything they wanted in his four years. Ask and you shall receive was the dynamic between himself and Benjamin Netanyahu orchestrated by Trump's ultra-Zionist son-in-law Jared Kushner, his ultra-Zionist Ambassador to Israel, David Friedman, and ultra-Zionist 'Israel adviser', Jason Greenblatt. The last two were central to the running and protecting from collapse of his business empire, the Trump Organisation, and colossal business failures made him forever beholding to Sabbatian networks that bailed him out. By the start of the 1990s Trump owed \$4 billion to banks that he couldn't pay and almost \$1 billion of that was down to him personally and not his companies. This mega-disaster was the result of building two new casinos in Atlantic City and buying the enormous Taj Mahal operation which led to crippling debt payments. He had borrowed fantastic sums from 72 banks with major Sabbatian connections and although the scale of debt should have had him living in a tent alongside the highway they never foreclosed. A plan was devised to lift Trump from the mire by BT Securities Corporation and Rothschild Inc. and the case was handled by Wilber Ross who had worked for the Rothschilds for 27 years. Ross would be named US Commerce Secretary after Trump's election. Another crucial figure in saving Trump was ultra-Zionist 'investor' Carl Icahn who bought the Taj Mahal casino. Icahn was made special economic adviser on financial regulation in the Trump administration. He didn't stay long but still managed to find time to make a tidy sum of a reported \$31.3 million when he sold his



holdings affected by the price of steel three days before Trump imposed a 235 percent tariff on steel imports. What amazing bits of luck these people have. Trump and Sabbatian operatives have long had a close association and his mentor and legal adviser from the early 1970s until 1986 was the dark and genetically corrupt ultra-Zionist Roy Cohn who was chief counsel to Senator Joseph McCarthy's 'communist' witch-hunt in the 1950s. *Esquire* magazine published an article about Cohn with the headline 'Don't mess with Roy Cohn'. He was described as the most feared lawyer in New York and 'a ruthless master of dirty tricks ... [with] ... more than one Mafia Don on speed dial'. Cohn's influence, contacts, support and protection made Trump a front man for Sabbatians in New York with their connections to one of Cohn's many criminal employers, the 'Russian' Sabbatian Mafia. Israel-centric media mogul Rupert Murdoch was introduced to Trump by Cohn and they started a long friendship. Cohn died in 1986 weeks after being disbarred for unethical conduct by the Appellate Division of the New York State Supreme Court. The wheels of justice do indeed run slow given the length of Cohn's crooked career.

## **QAnon-sense**

We are asked to believe that Donald Trump with his fundamental connections to Sabbatian networks and operatives has been leading the fight to stop the Sabbatian agenda for the fascistic control of America and the world. Sure he has. A man entrapped during his years in the White House by Sabbatian operatives and whose biggest financial donor was casino billionaire Sheldon Adelson who was Sabbatian to his DNA?? Oh, do come on. Trump has been used to divide America and isolate Pushbackers on the Cult agenda under the heading of 'Trump supporters', 'insurrectionists' and 'white supremacists'. The US Intelligence/Mossad Psyop or psychological operation known as QAnon emerged during the Trump years as a central pillar in the Sabbatian campaign to lead Pushbackers into the trap set by those that wished to destroy them. I knew from the start that QAnon was a scam because I had seen the same scenario many

times before over 30 years under different names and I had written about one in particular in the books. 'Not again' was my reaction when QAnon came to the fore. The same script is pulled out every few years and a new name added to the letterhead. The story always takes the same form: 'Insiders' or 'the good guys' in the government-intelligence-military 'Deep State' apparatus were going to instigate mass arrests of the 'bad guys' which would include the Rockefellers, Rothschilds, Barack Obama, Hillary Clinton, George Soros, etc., etc. Dates are given for when the 'good guys' are going to move in, but the dates pass without incident and new dates are given which pass without incident. The central message to Pushbackers in each case is that they don't have to do anything because there is 'a plan' and it is all going to be sorted by the 'good guys' on the inside. 'Trust the plan' was a QAnon mantra when the only plan was to misdirect Pushbackers into putting their trust in a Psyop they believed to be real. Beware, beware, those who tell you what you want to hear and always check it out. Right up to Biden's inauguration QAnon was still claiming that 'the Storm' was coming and Trump would stay on as president when Biden and his cronies were arrested and jailed. It was never going to happen and of course it didn't, but what did happen as a result provided that punchline to the Sabbatian Trump/QAnon Psyop.

On January 6th, 2021, a very big crowd of Trump supporters gathered in the National Mall in Washington DC down from the Capitol Building to protest at what they believed to be widespread corruption and vote fraud that stopped Trump being re-elected for a second term as president in November, 2020. I say as someone that does not support Trump or Biden that the evidence is clear that major vote-fixing went on to favour Biden, a man with cognitive problems so advanced he can often hardly string a sentence together without reading the words written for him on the Teleprompter. Glaring ballot discrepancies included serious questions about electronic voting machines that make vote rigging a comparative cinch and hundreds of thousands of paper votes that suddenly appeared during already advanced vote counts and virtually all of

them for Biden. Early Trump leads in crucial swing states suddenly began to close and disappear. The pandemic hoax was used as the excuse to issue almost limitless numbers of mail-in ballots with no checks to establish that the recipients were still alive or lived at that address. They were sent to streams of people who had not even asked for them. Private organisations were employed to gather these ballots and who knows what they did with them before they turned up at the counts. The American election system has been manipulated over decades to become a sick joke with more holes than a Swiss cheese for the express purpose of dictating the results. Then there was the criminal manipulation of information by Sabbatian tech giants like Facebook, Twitter and Google-owned YouTube which deleted pro-Trump, anti-Biden accounts and posts while everything in support of Biden was left alone. Sabbatians wanted Biden to win because after the dividing of America it was time for full-on Woke and every aspect of the Cult agenda to be unleashed.

### **Hunter gatherer**

Extreme Silicon Valley bias included blocking information by the *New York Post* exposing a Biden scandal that should have ended his bid for president in the final weeks of the campaign. Hunter Biden, his monumentally corrupt son, is reported to have sent a laptop to be repaired at a local store and failed to return for it. Time passed until the laptop became the property of the store for non-payment of the bill. When the owner saw what was on the hard drive he gave a copy to the FBI who did nothing even though it confirmed widespread corruption in which the Joe Biden family were using his political position, especially when he was vice president to Obama, to make multiple millions in countries around the world and most notably Ukraine and China. Hunter Biden's one-time business partner Tony Bobulinski went public when the story broke in the *New York Post* to confirm the corruption he saw and that Joe Biden not only knew what was going on he also profited from the spoils. Millions were handed over by a Chinese company with close

connections – like all major businesses in China – to the Chinese communist party of President Xi Jinping. Joe Biden even boasted at a meeting of the Cult's World Economic Forum that as vice president he had ordered the government of Ukraine to fire a prosecutor. What he didn't mention was that the same man just happened to be investigating an energy company which was part of Hunter Biden's corrupt portfolio. The company was paying him big bucks for no other reason than the influence his father had. Overnight Biden's presidential campaign should have been over given that he had lied publicly about not knowing what his son was doing. Instead almost the entire Sabbatian-owned mainstream media and Sabbatian-owned Silicon Valley suppressed circulation of the story. This alone went a mighty way to rigging the election of 2020. Cult assets like Mark Zuckerberg at Facebook also spent hundreds of millions to be used in support of Biden and vote 'administration'.

The Cult had used Trump as the focus to divide America and was now desperate to bring in moronic, pliable, corrupt Biden to complete the double-whammy. No way were they going to let little things like the will of the people thwart their plan. Silicon Valley widely censored claims that the election was rigged because it *was* rigged. For the same reason anyone claiming it was rigged was denounced as a 'white supremacist' including the pathetically few Republican politicians willing to say so. Right across the media where the claim was mentioned it was described as a 'false claim' even though these excuses for 'journalists' would have done no research into the subject whatsoever. Trump won seven million more votes than any sitting president had ever achieved while somehow a cognitively-challenged soon to be 78-year-old who was hidden away from the public for most of the campaign managed to win more votes than any presidential candidate in history. It makes no sense. You only had to see election rallies for both candidates to witness the enthusiasm for Trump and the apathy for Biden. Tens of thousands would attend Trump events while Biden was speaking in empty car parks with often only television crews attending and framing their shots to hide the fact that no one was there. It was pathetic to see

footage come to light of Biden standing at a podium making speeches only to TV crews and party fixers while reading the words written for him on massive Teleprompter screens. So, yes, those protestors on January 6th had a point about election rigging, but some were about to walk into a trap laid for them in Washington by the Cult Deep State and its QAnon Psyop. This was the Capitol Hill riot ludicrously dubbed an 'insurrection'.

## **The spider and the fly**

Renegade Minds know there are not two 'sides' in politics, only one side, the Cult, working through all 'sides'. It's a stage show, a puppet show, to direct the perceptions of the population into focusing on diversions like parties and candidates while missing the puppeteers with their hands holding all the strings. The Capitol Hill 'insurrection' brings us back to the Little Big Horn. Having created two distinct opposing groupings – Woke and Pushbackers – the trap was about to be sprung. Pushbackers were to be encircled and isolated by associating them all in the public mind with Trump and then labelling Trump as some sort of Confederate leader. I knew immediately that the Capitol riot was a set-up because of two things. One was how easy the rioters got into the building with virtually no credible resistance and secondly I could see – as with the 'Covid' hoax in the West at the start of 2020 – how the Cult could exploit the situation to move its agenda forward with great speed. My experience of Cult techniques and activities over more than 30 years has showed me that while they do exploit situations they haven't themselves created this never happens with events of fundamental agenda significance. Every time major events giving cultists the excuse to rapidly advance their plan you find they are manipulated into being for the specific reason of providing that excuse – Problem-Reaction-Solution. Only a tiny minority of the huge crowd of Washington protestors sought to gain entry to the Capitol by smashing windows and breaching doors. That didn't matter. The whole crowd and all Pushbackers, even if they did not support Trump, were going to be lumped together as dangerous

insurrectionists and conspiracy theorists. The latter term came into widespread use through a CIA memo in the 1960s aimed at discrediting those questioning the nonsensical official story of the Kennedy assassination and it subsequently became widely employed by the media. It's still being used by inept 'journalists' with no idea of its origin to discredit anyone questioning anything that authority claims to be true. When you are perpetrating a conspiracy you need to discredit the very word itself even though the dictionary definition of conspiracy is merely 'the activity of secretly planning with other people to do something bad or illegal' and 'a general agreement to keep silent about a subject for the purpose of keeping it secret'. On that basis there are conspiracies almost wherever you look. For obvious reasons the Cult and its lapdog media have to claim there are no conspiracies even though the word appears in state laws as with conspiracy to defraud, to murder, and to corrupt public morals.

Agent provocateurs are widely used by the Cult Deep State to manipulate genuine people into acting in ways that suit the desired outcome. By genuine in this case I mean protestors genuinely supporting Trump and claims that the election was stolen. In among them, however, were agents of the state wearing the garb of Trump supporters and QAnon to pump-prime the Capital riot which some genuine Trump supporters naively fell for. I described the situation as 'Come into my parlour said the spider to the fly'. Leaflets appeared through the Woke paramilitary arm Antifa, the anti-fascist fascists, calling on supporters to turn up in Washington looking like Trump supporters even though they hated him. Some of those arrested for breaching the Capitol Building were sourced to Antifa and its stable mate Black Lives Matter. Both organisations are funded by Cult billionaires and corporations. One man charged for the riot was according to his lawyer a former FBI agent who had held top secret security clearance for 40 years. Attorney Thomas Plofchan said of his client, 66-year-old Thomas Edward Caldwell:

He has held a Top Secret Security Clearance since 1979 and has undergone multiple Special Background Investigations in support of his clearances. After retiring from the Navy, he

worked as a section chief for the Federal Bureau of Investigation from 2009-2010 as a GS-12 [mid-level employee].

He also formed and operated a consulting firm performing work, often classified, for U.S government customers including the US Drug Enforcement Agency, Department of Housing and Urban Development, the US Coast Guard, and the US Army Personnel Command.

A judge later released Caldwell pending trial in the absence of evidence about a conspiracy or that he tried to force his way into the building. *The New York Post* reported a 'law enforcement source' as saying that 'at least two known Antifa members were spotted' on camera among Trump supporters during the riot while one of the rioters arrested was John Earle Sullivan, a seriously extreme Black Lives Matter Trump-hater from Utah who was previously arrested and charged in July, 2020, over a BLM-Antifa riot in which drivers were threatened and one was shot. Sullivan is the founder of Utah-based Insurgence USA which is an affiliate of the Cult-created-and-funded Black Lives Matter movement. Footage appeared and was then deleted by Twitter of Trump supporters calling out Antifa infiltrators and a group was filmed changing into pro-Trump clothing before the riot. Security at the building was *pathetic* – as planned. Colonel Leroy Fletcher Prouty, a man with long experience in covert operations working with the US security apparatus, once described the tell-tale sign to identify who is involved in an assassination. He said:

No one has to direct an assassination – it happens. The active role is played secretly by permitting it to happen. This is the greatest single clue. Who has the power to call off or reduce the usual security precautions?

This principle applies to many other situations and certainly to the Capitol riot of January 6th, 2021.

## **The sting**

With such a big and potentially angry crowd known to be gathering near the Capitol the security apparatus would have had a major police detail to defend the building with National Guard troops on

standby given the strength of feeling among people arriving from all over America encouraged by the QAnon Psyop and statements by Donald Trump. Instead Capitol Police 'security' was flimsy, weak, and easily breached. The same number of officers was deployed as on a regular day and that is a blatant red flag. They were not staffed or equipped for a possible riot that had been an obvious possibility in the circumstances. No protective and effective fencing worth the name was put in place and there were no contingency plans. The whole thing was basically a case of standing aside and waving people in. Once inside police mostly backed off apart from one Capitol police officer who ridiculously shot dead unarmed Air Force veteran protestor Ashli Babbitt without a warning as she climbed through a broken window. The 'investigation' refused to name or charge the officer after what must surely be considered a murder in the circumstances. They just lifted a carpet and swept. The story was endlessly repeated about five people dying in the 'armed insurrection' when there was no report of rioters using weapons. Apart from Babbitt the other four died from a heart attack, strokes and apparently a drug overdose. Capitol police officer Brian Sicknick was reported to have died after being bludgeoned with a fire extinguisher when he was alive after the riot was over and died later of what the Washington Medical Examiner's Office said was a stroke. Sicknick had no external injuries. The lies were delivered like rapid fire. There was a narrative to build with incessant repetition of the lie until the lie became the accepted 'everybody knows that' truth. The 'Big Lie' technique of Nazi Propaganda Minister Joseph Goebbels is constantly used by the Cult which was behind the Nazis and is today behind the 'Covid' and 'climate change' hoaxes. Goebbels said:

If you tell a lie big enough and keep repeating it, people will eventually come to believe it. The lie can be maintained only for such time as the State can shield the people from the political, economic and/or military consequences of the lie. It thus becomes vitally important for the State to use all of its powers to repress dissent, for the truth is the mortal enemy of the lie, and thus by extension, the truth is the greatest enemy of the State.



Most protestors had a free run of the Capitol Building. This allowed pictures to be taken of rioters in iconic parts of the building including the Senate chamber which could be used as propaganda images against all Pushbackers. One Congresswoman described the scene as 'the worst kind of non-security anybody could ever imagine'. Well, the first part was true, but someone obviously did imagine it and made sure it happened. Some photographs most widely circulated featured people wearing QAnon symbols and now the Psyop would be used to dub all QAnon followers with the ubiquitous fit-all label of 'white supremacist' and 'insurrectionists'. When a Muslim extremist called Noah Green drove his car at two police officers at the Capitol Building killing one in April, 2021, there was no such political and media hysteria. They were just disappointed he wasn't white.

## **The witch-hunt**

Government prosecutor Michael Sherwin, an aggressive, dark-eyed, professional Rottweiler led the 'investigation' and to call it over the top would be to understate reality a thousand fold. Hundreds were tracked down and arrested for the crime of having the wrong political views and people were jailed who had done nothing more than walk in the building, committed no violence or damage to property, took a few pictures and left. They were labelled a 'threat to the Republic' while Biden sat in the White House signing executive orders written for him that were dismantling 'the Republic'. Even when judges ruled that a mother and son should not be in jail the government kept them there. Some of those arrested have been badly beaten by prison guards in Washington and lawyers for one man said he suffered a fractured skull and was made blind in one eye. Meanwhile a woman is shot dead for no reason by a Capitol Police officer and we are not allowed to know who he is never mind what has happened to him although that will be *nothing*. The Cult's QAnon/Trump sting to identify and isolate Pushbackers and then target them on the road to crushing and deleting them was a resounding success. You would have thought the Russians had

invaded the building at gunpoint and lined up senators for a firing squad to see the political and media reaction. Congresswoman Alexandria Ocasio-Cortez is a child in a woman's body, a terrible-tvos, me, me, me, Woker narcissist of such proportions that words have no meaning. She said she thought she was going to die when 'insurrectionists' banged on her office door. It turned out she wasn't even in the Capitol Building when the riot was happening and the 'banging' was a Capitol Police officer. She referred to herself as a 'survivor' which is an insult to all those true survivors of violent and sexual abuse while she lives her pampered and privileged life talking drivel for a living. Her Woke colleague and fellow mega-narcissist Rashida Tlaib broke down describing the devastating effect on her, too, of *not being* in the building when the rioters were there. Ocasio-Cortez and Tlaib are members of a fully-Woke group of Congresswomen known as 'The Squad' along with Ilhan Omar and Ayanna Pressley. The Squad from what I can see can be identified by its vehement anti-white racism, anti-white men agenda, and, as always in these cases, the absence of brain cells on active duty.

The usual suspects were on the riot case immediately in the form of Democrat ultra-Zionist senators and operatives Chuck Schumer and Adam Schiff demanding that Trump be impeached for 'his part in the insurrection'. The same pair of prats had led the failed impeachment of Trump over the invented 'Russia collusion' nonsense which claimed Russia had helped Trump win the 2016 election. I didn't realise that Tel Aviv had been relocated just outside Moscow. I must find an up-to-date map. The Russia hoax was a Sabbatian operation to keep Trump occupied and impotent and to stop any rapport with Russia which the Cult wants to retain as a perceptual enemy to be pulled out at will. Puppet Biden began attacking Russia when he came to office as the Cult seeks more upheaval, division and war across the world. A two-year stage show 'Russia collusion inquiry' headed by the not-very-bright former 9/11 FBI chief Robert Mueller, with support from 19 lawyers, 40 FBI agents plus intelligence analysts, forensic accountants and other

staff, devoured tens of millions of dollars and found no evidence of Russia collusion which a ten-year-old could have told them on day one. Now the same moronic Schumer and Schiff wanted a second impeachment of Trump over the Capitol 'insurrection' (riot) which the arrested development of Schumer called another 'Pearl Harbor' while others compared it with 9/11 in which 3,000 died and, in the case of CNN, with the Rwandan genocide in the 1990s in which an estimated 500,000 to 600,000 were murdered, between 250,000 and 500,000 women were raped, and populations of whole towns were hacked to death with machetes. To make those comparisons purely for Cult political reasons is beyond insulting to those that suffered and lost their lives and confirms yet again the callous inhumanity that we are dealing with. Schumer is a monumental idiot and so is Schiff, but they serve the Cult agenda and do whatever they're told so they get looked after. Talking of idiots – another inane man who spanned the Russia and Capitol impeachment attempts was Senator Eric Swalwell who had the nerve to accuse Trump of collusion with the Russians while sleeping with a Chinese spy called Christine Fang or 'Fang Fang' which is straight out of a Bond film no doubt starring Klaus Schwab as the bloke living on a secret island and controlling laser weapons positioned in space and pointing at world capitals. Fang Fang plays the part of Bond's infiltrator girlfriend which I'm sure she would enjoy rather more than sharing a bed with the brainless Swalwell, lying back and thinking of China. The FBI eventually warned Swalwell about Fang Fang which gave her time to escape back to the Chinese dictatorship. How very thoughtful of them. The second Trump impeachment also failed and hardly surprising when an impeachment is supposed to remove a sitting president and by the time it happened Trump was no longer president. These people are running your country America, well, officially anyway. Terrifying isn't it?

### **Outcomes tell the story - always**

The outcome of all this – and it's the *outcome* on which Renegade Minds focus, not the words – was that a vicious, hysterical and

obviously pre-planned assault was launched on Pushbackers to censor, silence and discredit them and even targeted their right to earn a living. They have since been condemned as 'domestic terrorists' that need to be treated like Al-Qaeda and Islamic State. 'Domestic terrorists' is a label the Cult has been trying to make stick since the period of the Oklahoma bombing in 1995 which was blamed on 'far-right domestic terrorists'. If you read *The Trigger* you will see that the bombing was clearly a Problem-Reaction-Solution carried out by the Deep State during a Bill Clinton administration so corrupt that no dictionary definition of the term would even nearly suffice. Nearly 30, 000 troops were deployed from all over America to the empty streets of Washington for Biden's inauguration. Ten thousand of them stayed on with the pretext of protecting the capital from insurrectionists when it was more psychological programming to normalise the use of the military in domestic law enforcement in support of the Cult plan for a police-military state. Biden's fascist administration began a purge of 'wrong-thinkers' in the military which means anyone that is not on board with Woke. The Capitol Building was surrounded by a fence with razor wire and the Land of the Free was further symbolically and literally dismantled. The circle was completed with the installation of Biden and the exploitation of the QAnon Psyop.

America had never been so divided since the civil war of the 19th century, Pushbackers were isolated and dubbed terrorists and now, as was always going to happen, the Cult immediately set about deleting what little was left of freedom and transforming American society through a swish of the hand of the most controlled 'president' in American history leading (officially at least) the most extreme regime since the country was declared an independent state on July 4th, 1776. Biden issued undebated, dictatorial executive orders almost by the hour in his opening days in office across the whole spectrum of the Cult wish-list including diluting controls on the border with Mexico allowing thousands of migrants to illegally enter the United States to transform the demographics of America and import an election-changing number of perceived Democrat

voters. Then there were Biden deportation amnesties for the already illegally resident (estimated to be as high as 20 or even 30 million). A bill before Congress awarded American citizenship to anyone who could prove they had worked in agriculture for just 180 days in the previous two years as 'Big Ag' secured its slave labour long-term. There were the plans to add new states to the union such as Puerto Rico and making Washington DC a state. They are all parts of a plan to ensure that the Cult-owned Woke Democrats would be permanently in power.

### **Border – what border?**

I have exposed in detail in other books how mass immigration into the United States and Europe is the work of Cult networks fuelled by the tens of billions spent to this and other ends by George Soros and his global Open Society (open borders) Foundations. The impact can be seen in America alone where the population has increased by *100 million* in little more than 30 years mostly through immigration. I wrote in *The Answer* that the plan was to have so many people crossing the southern border that the numbers become unstoppable and we are now there under Cult-owned Biden. El Salvador in Central America puts the scale of what is happening into context. A third of the population now lives in the United States, much of it illegally, and many more are on the way. The methodology is to crush Central and South American countries economically and spread violence through machete-wielding psychopathic gangs like MS-13 based in El Salvador and now operating in many American cities. Biden-imposed lax security at the southern border means that it is all but open. He said before his 'election' that he wanted to see a surge towards the border if he became president and that was the green light for people to do just that after election day to create the human disaster that followed for both America and the migrants. When that surge came the imbecilic Alexandria Ocasio-Cortez said it wasn't a 'surge' because they are 'children, not insurgents' and the term 'surge' (used by Biden) was a claim of 'white supremacists'.

This disingenuous lady may one day enter the realm of the most basic intelligence, but it won't be any time soon.

Sabbatians and the Cult are in the process of destroying America by importing violent people and gangs in among the genuine to terrorise American cities and by overwhelming services that cannot cope with the sheer volume of new arrivals. Something similar is happening in Europe as Western society in general is targeted for demographic and cultural transformation and upheaval. The plan demands violence and crime to create an environment of intimidation, fear and division and Soros has been funding the election of district attorneys across America who then stop prosecuting many crimes, reduce sentences for violent crimes and free as many violent criminals as they can. Sabbatians are creating the chaos from which order – their order – can respond in a classic Problem-Reaction-Solution. A Freemasonic motto says 'Ordo Ab Chao' (Order out of Chaos) and this is why the Cult is constantly creating chaos to impose a new 'order'. Here you have the reason the Cult is constantly creating chaos. The 'Covid' hoax can be seen with those entering the United States by plane being forced to take a 'Covid' test while migrants flooding through southern border processing facilities do not. Nothing is put in the way of mass migration and if that means ignoring the government's own 'Covid' rules then so be it. They know it's all bullshit anyway. Any pushback on this is denounced as 'racist' by Wokers and Sabbatian fronts like the ultra-Zionist Anti-Defamation League headed by the appalling Jonathan Greenblatt which at the same time argues that Israel should not give citizenship and voting rights to more Palestinian Arabs or the 'Jewish population' (in truth the Sabbatian network) will lose control of the country.

## **Society-changing numbers**

Biden's masters have declared that countries like El Salvador are so dangerous that their people must be allowed into the United States for humanitarian reasons when there are fewer murders in large parts of many Central American countries than in US cities like

Baltimore. That is not to say Central America cannot be a dangerous place and Cult-controlled American governments have been making it so since way back, along with the dismantling of economies, in a long-term plan to drive people north into the United States. Parts of Central America are very dangerous, but in other areas the story is being greatly exaggerated to justify relaxing immigration criteria. Migrants are being offered free healthcare and education in the United States as another incentive to head for the border and there is no requirement to be financially independent before you can enter to prevent the resources of America being drained. You can't blame migrants for seeking what they believe will be a better life, but they are being played by the Cult for dark and nefarious ends. The numbers since Biden took office are huge. In February, 2021, more than 100,000 people were known to have tried to enter the US illegally through the southern border (it was 34,000 in the same month in 2020) and in March it was 170,000 – a 418 percent increase on March, 2020. These numbers are only known people, not the ones who get in unseen. The true figure for migrants illegally crossing the border in a single month was estimated by one congressman at 250,000 and that number will only rise under Biden's current policy. Gangs of murdering drug-running thugs that control the Mexican side of the border demand money – thousands of dollars – to let migrants cross the Rio Grande into America. At the same time gun battles are breaking out on the border several times a week between rival Mexican drug gangs (which now operate globally) who are equipped with sophisticated military-grade weapons, grenades and armoured vehicles. While the Capitol Building was being 'protected' from a non-existent 'threat' by thousands of troops, and others were still deployed at the time in the Cult Neocon war in Afghanistan, the southern border of America was left to its fate. This is not incompetence, it is cold calculation.

By March, 2021, there were 17,000 unaccompanied children held at border facilities and many of them are ensnared by people traffickers for paedophile rings and raped on their journey north to America. This is not conjecture – this is fact. Many of those designated

children are in reality teenage boys or older. Meanwhile Wokers posture their self-purity for encouraging poor and tragic people to come to America and face this nightmare both on the journey and at the border with the disgusting figure of House Speaker Nancy Pelosi giving disingenuous speeches about caring for migrants. The woman's evil. Wokers condemned Trump for having children in cages at the border (so did Obama, *Shhhh*), but now they are sleeping on the floor without access to a shower with one border facility 729 percent over capacity. The Biden insanity even proposed flying migrants from the southern border to the northern border with Canada for 'processing'. The whole shambles is being overseen by ultra-Zionist Secretary of Homeland Security, the moronic liar Alejandro Mayorkas, who banned news cameras at border facilities to stop Americans seeing what was happening. Mayorkas said there was not a ban on news crews; it was just that they were not allowed to film. Alongside him at Homeland Security is another ultra-Zionist Cass Sunstein appointed by Biden to oversee new immigration laws. Sunstein despises conspiracy researchers to the point where he suggests they should be banned or *taxed* for having such views. The man is not bonkers or anything. He's perfectly well-adjusted, but adjusted to what is the question. Criticise what is happening and you are a 'white supremacist' when earlier non-white immigrants also oppose the numbers which effect their lives and opportunities. Black people in poor areas are particularly damaged by uncontrolled immigration and the increased competition for work opportunities with those who will work for less. They are also losing voting power as Hispanics become more dominant in former black areas. It's a downward spiral for them while the billionaires behind the policy drone on about how much they care about black people and 'racism'. None of this is about compassion for migrants or black people – that's just wind and air. Migrants are instead being mercilessly exploited to transform America while the countries they leave are losing their future and the same is true in Europe. Mass immigration may now be the work of Woke Democrats, but it can be traced back to the 1986 Immigration Reform and Control Act (it



wasn't) signed into law by Republican hero President Ronald Reagan which gave amnesty to millions living in the United States illegally and other incentives for people to head for the southern border. Here we have the one-party state at work again.

## **Save me syndrome**

Almost every aspect of what I have been exposing as the Cult agenda was on display in even the first days of 'Biden' with silencing of Pushbackers at the forefront of everything. A Renegade Mind will view the Trump years and QAnon in a very different light to their supporters and advocates as the dots are connected. The QAnon/Trump Psyop has given the Cult all it was looking for. We may not know how much, or little, that Trump realised he was being used, but that's a side issue. This pincer movement produced the desired outcome of dividing America and having Pushbackers isolated. To turn this around we have to look at new routes to empowerment which do not include handing our power to other people and groups through what I will call the 'Save Me Syndrome' – 'I want someone else to do it so that I don't have to'. We have seen this at work throughout human history and the QAnon/Trump Psyop is only the latest incarnation alongside all the others. Religion is an obvious expression of this when people look to a 'god' or priest to save them or tell them how to be saved and then there are 'save me' politicians like Trump. Politics is a diversion and not a 'saviour'. It is a means to block positive change, not make it possible.

Save Me Syndrome always comes with the same repeating theme of handing your power to whom or what you believe will save you while your real 'saviour' stares back from the mirror every morning. Renegade Minds are constantly vigilant in this regard and always asking the question 'What can I do?' rather than 'What can someone else do for me?' Gandhi was right when he said: 'You must be the change you want to see in the world.' We are indeed the people we have been waiting for. We are presented with a constant raft of reasons to concede that power to others and forget where the real power is. Humanity has the numbers and the Cult does not. It has to

use diversion and division to target the unstoppable power that comes from unity. Religions, governments, politicians, corporations, media, QAnon, are all different manifestations of this power-diversion and dilution. Refusing to give your power to governments and instead handing it to Trump and QAnon is not to take a new direction, but merely to recycle the old one with new names on the posters. I will explore this phenomenon as we proceed and how to break the cycles and recycles that got us here through the mists of repeating perception and so repeating history.

For now we shall turn to the most potent example in the entire human story of the consequences that follow when you give your power away. I am talking, of course, of the 'Covid' hoax.

## CHAPTER FOUR

### **'Covid': Calculated catastrophe**

*Facts are threatening to those invested in fraud*  
DaShanne Stokes

**W**e can easily unravel the real reason for the 'Covid pandemic' hoax by employing the Renegade Mind methodology that I have outlined this far. We'll start by comparing the long-planned Cult outcome with the 'Covid pandemic' outcome. Know the outcome and you'll see the journey.

I have highlighted the plan for the Hunger Games Society which has been in my books for so many years with the very few controlling the very many through ongoing dependency. To create this dependency it is essential to destroy independent livelihoods, businesses and employment to make the population reliant on the state (the Cult) for even the basics of life through a guaranteed pittance income. While independence of income remained these Cult ambitions would be thwarted. With this knowledge it was easy to see where the 'pandemic' hoax was going once talk of 'lockdowns' began and the closing of all but perceived 'essential' businesses to 'save' us from an alleged 'deadly virus'. Cult corporations like Amazon and Walmart were naturally considered 'essential' while mom and pop shops and stores had their doors closed by fascist decree. As a result with every new lockdown and new regulation more small and medium, even large businesses not owned by the Cult, went to the wall while Cult giants and their frontmen and women grew financially fatter by the second. Mom and pop were

denied an income and the right to earn a living and the wealth of people like Jeff Bezos (Amazon), Mark Zuckerberg (Facebook) and Sergei Brin and Larry Page (Google/Alphabet) have reached record levels. The Cult was increasing its own power through further dramatic concentrations of wealth while the competition was being destroyed and brought into a state of dependency. Lockdowns have been instigated to secure that very end and were never anything to do with health. My brother Paul spent 45 years building up a bus repair business, but lockdowns meant buses were running at a fraction of normal levels for months on end. Similar stories can be told in their hundreds of millions worldwide. Efforts of a lifetime coldly destroyed by Cult multi-billionaires and their lackeys in government and law enforcement who continued to earn their living from the taxation of the people while denying the right of the same people to earn theirs. How different it would have been if those making and enforcing these decisions had to face the same financial hardships of those they affected, but they never do.

## **Gates of Hell**

Behind it all in the full knowledge of what he is doing and why is the psychopathic figure of Cult operative Bill Gates. His puppet Tedros at the World Health Organization declared 'Covid' a pandemic in March, 2020. The WHO had changed the definition of a 'pandemic' in 2009 just a month before declaring the 'swine flu pandemic' which would not have been so under the previous definition. The same applies to 'Covid'. The definition had included... 'an infection by an infectious agent, occurring simultaneously in different countries, with a significant mortality rate relative to the proportion of the population infected'. The new definition removed the need for 'significant mortality'. The 'pandemic' has been fraudulent even down to the definition, but Gates demanded economy-destroying lockdowns, school closures, social distancing, mandatory masks, a 'vaccination' for every man, woman and child on the planet and severe consequences and restrictions for those that refused. Who gave him this power? The

Cult did which he serves like a little boy in short trousers doing what his daddy tells him. He and his psychopathic missus even smiled when they said that much worse was to come (what they knew was planned to come). Gates responded in the matter-of-fact way of all psychopaths to a question about the effect on the world economy of what he was doing:

Well, it won't go to zero but it will shrink. Global GDP is probably going to take the biggest hit ever [Gates was smiling as he said this] ... in my lifetime this will be the greatest economic hit. But you don't have a choice. People act as if you have a choice. People don't feel like going to the stadium when they might get infected ... People are deeply affected by seeing these stats, by knowing they could be part of the transmission chain, old people, their parents and grandparents, could be affected by this, and so you don't get to say ignore what is going on here.

There will be the ability to open up, particularly in rich countries, if things are done well over the next few months, but for the world at large normalcy only returns when we have largely vaccinated the entire population.

The man has no compassion or empathy. How could he when he's a psychopath like all Cult players? My own view is that even beyond that he is very seriously mentally ill. Look in his eyes and you can see this along with his crazy flailing arms. You don't do what he has done to the world population since the start of 2020 unless you are mentally ill and at the most extreme end of psychopathic. You especially don't do it when to you know, as we shall see, that cases and deaths from 'Covid' are fakery and a product of monumental figure massaging. 'These stats' that Gates referred to are based on a 'test' that's not testing for the 'virus' as he has known all along. He made his fortune with big Cult support as an infamously ruthless software salesman and now buys global control of 'health' (death) policy without the population he affects having any say. It's a breathtaking outrage. Gates talked about people being deeply affected by fear of 'Covid' when that was because of *him* and his global network lying to them minute-by-minute supported by a lying media that he seriously influences and funds to the tune of hundreds of millions. He's handed big sums to media operations including the BBC, NBC, Al Jazeera, Univision, *PBS NewsHour*,

*ProPublica, National Journal, The Guardian, The Financial Times, The Atlantic, Texas Tribune, USA Today publisher Gannett, Washington Monthly, Le Monde, Center for Investigative Reporting, Pulitzer Center on Crisis Reporting, National Press Foundation, International Center for Journalists, Solutions Journalism Network, the Poynter Institute for Media Studies, and many more. Gates is everywhere in the 'Covid' hoax and the man must go to prison – or a mental facility – for the rest of his life and his money distributed to those he has taken such enormous psychopathic pleasure in crushing.*

## **The Muscle**

The Hunger Games global structure demands a police-military state – a fusion of the two into one force – which viciously imposes the will of the Cult on the population and protects the Cult from public rebellion. In that regard, too, the 'Covid' hoax just keeps on giving. Often unlawful, ridiculous and contradictory 'Covid' rules and regulations have been policed across the world by moronic automatons and psychopaths made faceless by face-nappy masks and acting like the Nazi SS and fascist blackshirts and brownshirts of Hitler and Mussolini. The smallest departure from the rules decreed by the psychos in government and their clueless gofers were jumped upon by the face-nappy fascists. Brutality against public protestors soon became commonplace even on girls, women and old people as the brave men with the batons – the Face-Nappies as I call them – broke up peaceful protests and handed out fines like confetti to people who couldn't earn a living let alone pay hundreds of pounds for what was once an accepted human right. Robot Face-Nappies of Nottingham police in the English East Midlands fined one group £11,000 for attending a child's birthday party. For decades I charted the transformation of law enforcement as genuine, decent officers were replaced with psychopaths and the brain dead who would happily and brutally do whatever their masters told them. Now they were let loose on the public and I would emphasise the point that none of this just happened. The step-by-step change in the dynamic between police and public was orchestrated from the shadows by

those who knew where this was all going and the same with the perceptual reframing of those in all levels of authority and official administration through 'training courses' by organisations such as Common Purpose which was created in the late 1980s and given a massive boost in Blair era Britain until it became a global phenomenon. Supposed public 'servants' began to view the population as the enemy and the same was true of the police. This was the start of the explosion of behaviour manipulation organisations and networks preparing for the all-war on the human psyche unleashed with the dawn of 2020. I will go into more detail about this later in the book because it is a core part of what is happening.

Police desecrated beauty spots to deter people gathering and arrested women for walking in the countryside alone 'too far' from their homes. We had arrogant, clueless sergeants in the Isle of Wight police where I live posting on Facebook what they insisted the population must do or else. A schoolmaster sergeant called Radford looked young enough for me to ask if his mother knew he was out, but he was posting what he *expected* people to do while a Sergeant Wilkinson boasted about fining lads for meeting in a McDonald's car park where they went to get a lockdown takeaway. Wilkinson added that he had even cancelled their order. What a pair of prats these people are and yet they have increasingly become the norm among Jackboot Johnson's Yellowshirts once known as the British police. This was the theme all over the world with police savagery common during lockdown protests in the United States, the Netherlands, and the fascist state of Victoria in Australia under its tyrannical and again moronic premier Daniel Andrews. Amazing how tyrannical and moronic tend to work as a team and the same combination could be seen across America as arrogant, narcissistic Woke governors and mayors such as Gavin Newsom (California), Andrew Cuomo (New York), Gretchen Whitmer (Michigan), Lori Lightfoot (Chicago) and Eric Garcetti (Los Angeles) did their Nazi and Stalin impressions with the full support of the compliant brutality of their enforcers in uniform as they arrested small business owners defying

fascist shutdown orders and took them to jail in ankle shackles and handcuffs. This happened to bistro owner Marlena Pavlos-Hackney in Gretchen Whitmer's fascist state of Michigan when police arrived to enforce an order by a state-owned judge for 'putting the community at risk' at a time when other states like Texas were dropping restrictions and migrants were pouring across the southern border without any 'Covid' questions at all. I'm sure there are many officers appalled by what they are ordered to do, but not nearly enough of them. If they were truly appalled they would not do it. As the months passed every opportunity was taken to have the military involved to make their presence on the streets ever more familiar and 'normal' for the longer-term goal of police-military fusion.

Another crucial element to the Hunger Games enforcement network has been encouraging the public to report neighbours and others for 'breaking the lockdown rules'. The group faced with £11,000 in fines at the child's birthday party would have been dobbed-in by a neighbour with a brain the size of a pea. The technique was most famously employed by the Stasi secret police in communist East Germany who had public informants placed throughout the population. A police chief in the UK says his force doesn't need to carry out 'Covid' patrols when they are flooded with so many calls from the public reporting other people for visiting the beach. Dorset police chief James Vaughan said people were so enthusiastic about snitching on their fellow humans they were now operating as an auxiliary arm of the police: 'We are still getting around 400 reports a week from the public, so we will respond to reports ... We won't need to be doing hotspot patrols because people are very quick to pick the phone up and tell us.' Vaughan didn't say that this is a pillar of all tyrannies of whatever complexion and the means to hugely extend the reach of enforcement while spreading distrust among the people and making them wary of doing anything that might get them reported. Those narcissistic Isle of Wight sergeants Radford and Wilkinson never fail to add a link to their Facebook posts where the public can inform on their fellow slaves.



Neither would be self-aware enough to realise they were imitating the Stasi which they might well never have heard of. Government psychologists that I will expose later laid out a policy to turn communities against each other in the same way.

### **A coincidence? Yep, and I can knit fog**

I knew from the start of the alleged pandemic that this was a Cult operation. It presented limitless potential to rapidly advance the Cult agenda and exploit manipulated fear to demand that every man, woman and child on the planet was 'vaccinated' in a process never used on humans before which infuses self-replicating *synthetic* material into human cells. Remember the plan to transform the human body from a biological to a synthetic biological state. I'll deal with the 'vaccine' (that's not actually a vaccine) when I focus on the genetic agenda. Enough to say here that mass global 'vaccination' justified by this 'new virus' set alarms ringing after 30 years of tracking these people and their methods. The 'Covid' hoax officially beginning in China was also a big red flag for reasons I will be explaining. The agenda potential was so enormous that I could dismiss any idea that the 'virus' appeared naturally. Major happenings with major agenda implications never occur without Cult involvement in making them happen. My questions were twofold in early 2020 as the media began its campaign to induce global fear and hysteria: Was this alleged infectious agent released on purpose by the Cult or did it even exist at all? I then did what I always do in these situations. I sat, observed and waited to see where the evidence and information would take me. By March and early April synchronicity was strongly – and ever more so since then – pointing me in the direction of *there is no 'virus'*. I went public on that with derision even from swathes of the alternative media that voiced a scenario that the Chinese government released the 'virus' in league with Deep State elements in the United States from a top-level bio-lab in Wuhan where the 'virus' is said to have first appeared. I looked at that possibility, but I didn't buy it for several reasons. Deaths from the 'virus' did not in any way match what they

would have been with a 'deadly bioweapon' and it is much more effective if you sell the *illusion* of an infectious agent rather than having a real one unless you can control through injection who has it and who doesn't. Otherwise you lose control of events. A made-up 'virus' gives you a blank sheet of paper on which you can make it do whatever you like and have any symptoms or mutant 'variants' you choose to add while a real infectious agent would limit you to what it actually does. A phantom disease allows you to have endless ludicrous 'studies' on the 'Covid' dollar to widen the perceived impact by inventing ever more 'at risk' groups including one study which said those who walk slowly may be almost four times more likely to die from the 'virus'. People are in psychiatric wards for less.

A real 'deadly bioweapon' can take out people in the hierarchy that are not part of the Cult, but essential to its operation. Obviously they don't want that. Releasing a real disease means you immediately lose control of it. Releasing an illusory one means you don't. Again it's vital that people are extra careful when dealing with what they want to hear. A bioweapon unleashed from a Chinese laboratory in collusion with the American Deep State may fit a conspiracy narrative, but is it true? Would it not be far more effective to use the excuse of a 'virus' to justify the real bioweapon – the 'vaccine'? That way your disease agent does not have to be transmitted and arrives directly through a syringe. I saw a French virologist Luc Montagnier quoted in the alternative media as saying he had discovered that the alleged 'new' severe acute respiratory syndrome coronavirus, or SARS-CoV-2, was made artificially and included elements of the human immunodeficiency 'virus' (HIV) and a parasite that causes malaria. SARS-CoV-2 is alleged to trigger an alleged illness called Covid-19. I remembered Montagnier's name from my research years before into claims that an HIV 'retrovirus' causes AIDs – claims that were demolished by Berkeley virologist Peter Duesberg who showed that no one had ever proved that HIV causes acquired immunodeficiency syndrome or AIDS. Claims that become accepted as fact, publicly and medically, with no proof whatsoever are an ever-recurring story that profoundly applies to

'Covid'. Nevertheless, despite the lack of proof, Montagnier's team at the Pasteur Institute in Paris had a long dispute with American researcher Robert Gallo over which of them discovered and isolated the HIV 'virus' and with *no evidence* found it to cause AIDS. You will see later that there is also no evidence that any 'virus' causes any disease or that there is even such a thing as a 'virus' in the way it is said to exist. The claim to have 'isolated' the HIV 'virus' will be presented in its real context as we come to the shocking story – and it is a story – of SARS-CoV-2 and so will Montagnier's assertion that he identified the full SARS-CoV-2 genome.

### **Hoax in the making**

We can pick up the 'Covid' story in 2010 and the publication by the Rockefeller Foundation of a document called 'Scenarios for the Future of Technology and International Development'. The inner circle of the Rockefeller family has been serving the Cult since John D. Rockefeller (1839-1937) made his fortune with Standard Oil. It is less well known that the same Rockefeller – the Bill Gates of his day – was responsible for establishing what is now referred to as 'Big Pharma', the global network of pharmaceutical companies that make outrageous profits dispensing scalpel and drug 'medicine' and are obsessed with pumping vaccines in ever-increasing number into as many human arms and backsides as possible. John D. Rockefeller was the driving force behind the creation of the 'education' system in the United States and elsewhere specifically designed to program the perceptions of generations thereafter. The Rockefeller family donated exceptionally valuable land in New York for the United Nations building and were central in establishing the World Health Organization in 1948 as an agency of the UN which was created from the start as a Trojan horse and stalking horse for world government. Now enter Bill Gates. His family and the Rockefellers have long been extremely close and I have seen genealogy which claims that if you go back far enough the two families fuse into the same bloodline. Gates has said that the Bill and Melinda Gates Foundation was inspired by the Rockefeller Foundation and why not

when both are serving the same Cult? Major tax-exempt foundations are overwhelmingly criminal enterprises in which Cult assets fund the Cult agenda in the guise of 'philanthropy' while avoiding tax in the process. Cult operatives can become mega-rich in their role of front men and women for the psychopaths at the inner core and they, too, have to be psychopaths to knowingly serve such evil. Part of the deal is that a big percentage of the wealth gleaned from representing the Cult has to be spent advancing the ambitions of the Cult and hence you have the Rockefeller Foundation, Bill and Melinda Gates Foundation (and *so* many more) and people like George Soros with his global Open Society Foundations spending their billions in pursuit of global Cult control. Gates is a global public face of the Cult with his interventions in world affairs including Big Tech influence; a central role in the 'Covid' and 'vaccine' scam; promotion of the climate change shakedown; manipulation of education; geoengineering of the skies; and his food-control agenda as the biggest owner of farmland in America, his GMO promotion and through other means. As one writer said: 'Gates monopolizes or wields disproportionate influence over the tech industry, global health and vaccines, agriculture and food policy (including biopiracy and fake food), weather modification and other climate technologies, surveillance, education and media.' The almost limitless wealth secured through Microsoft and other not-allowed-to-fail ventures (including vaccines) has been ploughed into a long, long list of Cult projects designed to enslave the entire human race. Gates and the Rockefellers have been working as one unit with the Rockefeller-established World Health Organization leading global 'Covid' policy controlled by Gates through his mouth-piece Tedros. Gates became the WHO's biggest funder when Trump announced that the American government would cease its donations, but Biden immediately said he would restore the money when he took office in January, 2021. The Gates Foundation (the Cult) owns through limitless funding the world health system and the major players across the globe in the 'Covid' hoax.

Okay, with that background we return to that Rockefeller Foundation document of 2010 headed 'Scenarios for the Future of Technology and International Development' and its 'imaginary' epidemic of a virulent and deadly influenza strain which infected 20 percent of the global population and killed eight million in seven months. The Rockefeller scenario was that the epidemic destroyed economies, closed shops, offices and other businesses and led to governments imposing fierce rules and restrictions that included mandatory wearing of face masks and body-temperature checks to enter communal spaces like railway stations and supermarkets. The document predicted that even after the height of the Rockefeller-envisaged epidemic the authoritarian rule would continue to deal with further pandemics, transnational terrorism, environmental crises and rising poverty. Now you may think that the Rockefellers are our modern-day seers or alternatively, and rather more likely, that they well knew what was planned a few years further on. Fascism had to be imposed, you see, to 'protect citizens from risk and exposure'. The Rockefeller scenario document said:

During the pandemic, national leaders around the world flexed their authority and imposed airtight rules and restrictions, from the mandatory wearing of face masks to body-temperature checks at the entries to communal spaces like train stations and supermarkets. Even after the pandemic faded, this more authoritarian control and oversight of citizens and their activities stuck and even intensified. In order to protect themselves from the spread of increasingly global problems – from pandemics and transnational terrorism to environmental crises and rising poverty – leaders around the world took a firmer grip on power.

At first, the notion of a more controlled world gained wide acceptance and approval. Citizens willingly gave up some of their sovereignty – and their privacy – to more paternalistic states in exchange for greater safety and stability. Citizens were more tolerant, and even eager, for top-down direction and oversight, and national leaders had more latitude to impose order in the ways they saw fit.

In developed countries, this heightened oversight took many forms: biometric IDs for all citizens, for example, and tighter regulation of key industries whose stability was deemed vital to national interests. In many developed countries, enforced cooperation with a suite of new regulations and agreements slowly but steadily restored both order and, importantly, economic growth.

There we have the prophetic Rockefellers in 2010 and three years later came their paper for the Global Health Summit in Beijing, China, when government representatives, the private sector, international organisations and groups met to discuss the next 100 years of 'global health'. The Rockefeller Foundation-funded paper was called 'Dreaming the Future of Health for the Next 100 Years and more prophecy ensued as it described a dystopian future: 'The abundance of data, digitally tracking and linking people may mean the 'death of privacy' and may replace physical interaction with transient, virtual connection, generating isolation and raising questions of how values are shaped in virtual networks.' Next in the 'Covid' hoax preparation sequence came a 'table top' simulation in 2018 for another 'imaginary' pandemic of a disease called Clade X which was said to kill 900 million people. The exercise was organised by the Gates-funded Johns Hopkins University's Center for Health Security in the United States and this is the very same university that has been compiling the disgustingly and systematically erroneous global figures for 'Covid' cases and deaths. Similar Johns Hopkins health crisis scenarios have included the Dark Winter exercise in 2001 and Atlantic Storm in 2005.

## **Nostradamus 201**

For sheer predictive genius look no further prophecy-watchers than the Bill Gates-funded Event 201 held only six weeks before the 'coronavirus pandemic' is supposed to have broken out in China and Event 201 was based on a scenario of a global 'coronavirus pandemic'. Melinda Gates, the great man's missus, told the BBC that he had 'prepared for years' for a coronavirus pandemic which told us what we already knew. Nostradamugates had predicted in a TED talk in 2015 that a pandemic was coming that would kill a lot of people and demolish the world economy. My god, the man is a machine – possibly even literally. Now here he was only weeks before the real thing funding just such a simulated scenario and involving his friends and associates at Johns Hopkins, the World Economic Forum Cult-front of Klaus Schwab, the United Nations,

Johnson & Johnson, major banks, and officials from China and the Centers for Disease Control in the United States. What synchronicity – Johns Hopkins would go on to compile the fraudulent ‘Covid’ figures, the World Economic Forum and Schwab would push the ‘Great Reset’ in response to ‘Covid’, the Centers for Disease Control would be at the forefront of ‘Covid’ policy in the United States, Johnson & Johnson would produce a ‘Covid vaccine’, and everything would officially start just weeks later in China. Spooky, eh? They were even accurate in creating a simulation of a ‘virus’ pandemic because the ‘real thing’ would also be a simulation. Event 201 was not an exercise preparing for something that might happen; it was a rehearsal for what those in control knew was *going* to happen and very shortly. Hours of this simulation were posted on the Internet and the various themes and responses mirrored what would soon be imposed to transform human society. News stories were inserted and what they said would be commonplace a few weeks later with still more prophecy perfection. Much discussion focused on the need to deal with misinformation and the ‘anti-vax movement’ which is exactly what happened when the ‘virus’ arrived – was said to have arrived – in the West.

Cult-owned social media banned criticism and exposure of the official ‘virus’ narrative and when I said there *was* no ‘virus’ in early April, 2020, I was banned by one platform after another including YouTube, Facebook and later Twitter. The mainstream broadcast media in Britain was in effect banned from interviewing me by the Tony-Blair-created government broadcasting censor Ofcom headed by career government bureaucrat Melanie Dawes who was appointed just as the ‘virus’ hoax was about to play out in January, 2020. At the same time the Ickonic media platform was using Vimeo, another ultra-Zionist-owned operation, while our own player was being created and they deleted in an instant hundreds of videos, documentaries, series and shows to confirm their unbelievable vindictiveness. We had copies, of course, and they had to be restored one by one when our player was ready. These people have no class. Sabbatian Facebook promised free advertisements for the Gates-

controlled World Health Organization narrative while deleting ‘false claims and conspiracy theories’ to stop ‘misinformation’ about the alleged coronavirus. All these responses could be seen just a short while earlier in the scenarios of Event 201. Extreme censorship was absolutely crucial for the Cult because the official story was so ridiculous and unsupportable by the evidence that it could never survive open debate and the free-flow of information and opinion. If you can’t win a debate then don’t have one is the Cult’s approach throughout history. Facebook’s little boy front man – front boy – Mark Zuckerberg equated ‘credible and accurate information’ with official sources and exposing their lies with ‘misinformation’.

### **Silencing those that can see**

The censorship dynamic of Event 201 is now the norm with an army of narrative-supporting ‘fact-checker’ organisations whose entire reason for being is to tell the public that official narratives are true and those exposing them are lying. One of the most appalling of these ‘fact-checkers’ is called NewsGuard founded by ultra-Zionist Americans Gordon Crovitz and Steven Brill. Crovitz is a former publisher of *The Wall Street Journal*, former Executive Vice President of Dow Jones, a member of the Council on Foreign Relations (CFR), and on the board of the American Association of Rhodes Scholars. The CFR and Rhodes Scholarships, named after Rothschild agent Cecil Rhodes who plundered the gold and diamonds of South Africa for his masters and the Cult, have featured widely in my books. NewsGuard don’t seem to like me for some reason – I really can’t think why – and they have done all they can to have me censored and discredited which is, to quote an old British politician, like being savaged by a dead sheep. They are, however, like all in the censorship network, very well connected and funded by organisations themselves funded by, or connected to, Bill Gates. As you would expect with anything associated with Gates NewsGuard has an offshoot called HealthGuard which ‘fights online health care hoaxes’. How very kind. Somehow the NewsGuard European Managing Director Anna-Sophie Harling, a remarkably young-



looking woman with no broadcasting experience and little hands-on work in journalism, has somehow secured a position on the 'Content Board' of UK government broadcast censor Ofcom. An executive of an organisation seeking to discredit dissidents of the official narratives is making decisions for the government broadcast 'regulator' about content?? Another appalling 'fact-checker' is Full Fact funded by George Soros and global censors Google and Facebook.

It's amazing how many activists in the 'fact-checking', 'anti-hate', arena turn up in government-related positions – people like UK Labour Party activist Imran Ahmed who heads the Center for Countering Digital Hate founded by people like Morgan McSweeney, now chief of staff to the Labour Party's hapless and useless 'leader' Keir Starmer. Digital Hate – which is what it really is – uses the American spelling of Center to betray its connection to a transatlantic network of similar organisations which in 2020 shapeshifted from attacking people for 'hate' to attacking them for questioning the 'Covid' hoax and the dangers of the 'Covid vaccine'. It's just a coincidence, you understand. This is one of Imran Ahmed's hysterical statements: 'I would go beyond calling anti-vaxxers conspiracy theorists to say they are an extremist group that pose a national security risk.' No one could ever accuse this prat of understatement and he's including in that those parents who are now against vaccines after their children were damaged for life or killed by them. He's such a nice man. Ahmed does the rounds of the Woke media getting soft-ball questions from spineless 'journalists' who never ask what right he has to campaign to destroy the freedom of speech of others while he demands it for himself. There also seems to be an overrepresentation in Ofcom of people connected to the narrative-worshipping BBC. This incredible global network of narrative-support was super-vital when the 'Covid' hoax was played in the light of the mega-whopper lies that have to be defended from the spotlight cast by the most basic intelligence.

## **Setting the scene**

The Cult plays the long game and proceeds step-by-step ensuring that everything is in place before major cards are played and they don't come any bigger than the 'Covid' hoax. The psychopaths can't handle events where the outcome isn't certain and as little as possible – preferably nothing – is left to chance. Politicians, government and medical officials who would follow direction were brought to illusory power in advance by the Cult web whether on the national stage or others like state governors and mayors of America. For decades the dynamic between officialdom, law enforcement and the public was changed from one of service to one of control and dictatorship. Behaviour manipulation networks established within government were waiting to impose the coming 'Covid' rules and regulations specifically designed to subdue and rewire the psyche of the people in the guise of protecting health. These included in the UK the Behavioural Insights Team part-owned by the British government Cabinet Office; the Scientific Pandemic Insights Group on Behaviours (SPI-B); and a whole web of intelligence and military groups seeking to direct the conversation on social media and control the narrative. Among them are the cyberwarfare (on the people) 77th Brigade of the British military which is also coordinated through the Cabinet Office as civilian and military leadership continues to combine in what they call the Fusion Doctrine. The 77th Brigade is a British equivalent of the infamous Israeli (Sabbatian) military cyberwarfare and Internet manipulation operation Unit 8200 which I expose at length in *The Trigger*. Also carefully in place were the medical and science advisers to government – many on the payroll past or present of Bill Gates – and a whole alternative structure of unelected government stood by to take control when elected parliaments were effectively closed down once the 'Covid' card was slammed on the table. The structure I have described here and so much more was installed in every major country through the Cult networks. The top-down control hierarchy looks like this: The Cult – Cult-owned Gates – the World Health Organization and Tedros – Gates-funded or controlled chief medical officers and science 'advisers' (dictators) in each country –

political 'leaders' – law enforcement – The People. Through this simple global communication and enforcement structure the policy of the Cult could be imposed on virtually the entire human population so long as they acquiesced to the fascism. With everything in place it was time for the button to be pressed in late 2019/early 2020.

These were the prime goals the Cult had to secure for its will to prevail:

1) Locking down economies, closing all but designated 'essential' businesses (Cult-owned corporations were 'essential'), and putting the population under house arrest was an imperative to destroy independent income and employment and ensure dependency on the Cult-controlled state in the Hunger Games Society. Lockdowns had to be established as the global blueprint from the start to respond to the 'virus' and followed by pretty much the entire world.

2) The global population had to be terrified into believing in a deadly 'virus' that didn't actually exist so they would unquestioningly obey authority in the belief that authority must know how best to protect them and their families. Software salesman Gates would suddenly morph into the world's health expert and be promoted as such by the Cult-owned media.

3) A method of testing that wasn't testing for the 'virus', but was only claimed to be, had to be in place to provide the illusion of 'cases' and subsequent 'deaths' that had a very different cause to the 'Covid-19' that would be scribbled on the death certificate.

4) Because there was no 'virus' and the great majority testing positive with a test not testing for the 'virus' would have no symptoms of anything the lie had to be sold that people without symptoms (without the 'virus') could still pass it on to others. This was crucial to justify for the first time quarantining – house arresting – healthy people. Without this the economy-destroying lockdown of *everybody* could not have been credibly sold.

5) The 'saviour' had to be seen as a vaccine which beyond evil drug companies were working like angels of mercy to develop as quickly as possible, with all corners cut, to save the day. The public must absolutely not know that the 'vaccine' had nothing to do with a 'virus' or that the contents were ready and waiting with a very different motive long before the 'Covid' card was even lifted from the pack.

I said in March, 2020, that the 'vaccine' would have been created way ahead of the 'Covid' hoax which justified its use and the following December an article in the New York *Intelligencer* magazine said the Moderna 'vaccine' had been 'designed' by

January, 2020. This was 'before China had even acknowledged that the disease could be transmitted from human to human, more than a week before the first confirmed coronavirus case in the United States'. The article said that by the time the first American death was announced a month later 'the vaccine had already been manufactured and shipped to the National Institutes of Health for the beginning of its Phase I clinical trial'. The 'vaccine' was actually 'designed' long before that although even with this timescale you would expect the article to ask how on earth it could have been done that quickly. Instead it asked why the 'vaccine' had not been rolled out then and not months later. Journalism in the mainstream is truly dead. I am going to detail in the next chapter why the 'virus' has never existed and how a hoax on that scale was possible, but first the foundation on which the Big Lie of 'Covid' was built.

### **The test that doesn't test**

Fraudulent 'testing' is the bottom line of the whole 'Covid' hoax and was the means by which a 'virus' that did not exist *appeared* to exist. They could only achieve this magic trick by using a test not testing for the 'virus'. To use a test that *was* testing for the 'virus' would mean that every test would come back negative given there was no 'virus'. They chose to exploit something called the RT-PCR test invented by American biochemist Kary Mullis in the 1980s who said publicly that his PCR test ... *cannot detect infectious disease*. Yes, the 'test' used worldwide to detect infectious 'Covid' to produce all the illusory 'cases' and 'deaths' compiled by Johns Hopkins and others *cannot detect infectious disease*. This fact came from the mouth of the man who invented PCR and was awarded the Nobel Prize in Chemistry in 1993 for doing so. Sadly, and incredibly conveniently for the Cult, Mullis died in August, 2019, at the age of 74 just before his test would be fraudulently used to unleash fascism on the world. He was said to have died from pneumonia which was an irony in itself. A few months later he would have had 'Covid-19' on his death certificate. I say the timing of his death was convenient because had he lived Mullis, a brilliant, honest and decent man, would have been

vociferously speaking out against the use of his test to detect 'Covid' when it was never designed, or able, to do that. I know that to be true given that Mullis made the same point when his test was used to 'detect' – not detect – HIV. He had been seriously critical of the Gallo/Montagnier claim to have isolated the HIV 'virus' and shown it to cause AIDS for which Mullis said there was no evidence. AIDS is actually not a disease but a series of diseases from which people die all the time. When they die from those *same diseases* after a positive 'test' for HIV then AIDS goes on their death certificate. I think I've heard that before somewhere. Countries instigated a policy with 'Covid' that anyone who tested positive with a test not testing for the 'virus' and died of any other cause within 28 days and even longer 'Covid-19' had to go on the death certificate. Cases have come from the test that can't test for infectious disease and the deaths are those who have died of *anything* after testing positive with a test not testing for the 'virus'. I'll have much more later about the death certificate scandal.

Mullis was deeply dismissive of the now US 'Covid' star Anthony Fauci who he said was a liar who didn't know anything about anything – 'and I would say that to his face – nothing.' He said of Fauci: 'The man thinks he can take a blood sample, put it in an electron microscope and if it's got a virus in there you'll know it – he doesn't understand electron microscopy and he doesn't understand medicine and shouldn't be in a position like he's in.' That position, terrifyingly, has made him the decider of 'Covid' fascism policy on behalf of the Cult in his role as director since 1984 of the National Institute of Allergy and Infectious Diseases (NIAID) while his record of being wrong is laughable; but being wrong, so long as it's the *right kind* of wrong, is why the Cult loves him. He'll say anything the Cult tells him to say. Fauci was made Chief Medical Adviser to the President immediately Biden took office. Biden was installed in the White House by Cult manipulation and one of his first decisions was to elevate Fauci to a position of even more control. This is a coincidence? Yes, and I identify as a flamenco dancer called Lola. How does such an incompetent criminal like Fauci remain in that

pivotal position in American health since *the 1980s*? When you serve the Cult it looks after you until you are surplus to requirements. Kary Mullis said prophetically of Fauci and his like: 'Those guys have an agenda and it's not an agenda we would like them to have ... they make their own rules, they change them when they want to, and Tony Fauci does not mind going on television in front of the people who pay his salary and lie directly into the camera.' Fauci has done that almost daily since the 'Covid' hoax began. Lying is in Fauci's DNA. To make the situation crystal clear about the PCR test this is a direct quote from its inventor Kary Mullis:

It [the PCR test] doesn't tell you that you're sick and doesn't tell you that the thing you ended up with was really going to hurt you ...'

Ask yourself why governments and medical systems the world over have been using this very test to decide who is 'infected' with the SARS-CoV-2 'virus' and the alleged disease it allegedly causes, 'Covid-19'. The answer to that question will tell you what has been going on. By the way, here's a little show-stopper – the 'new' SARS-CoV-2 'virus' was 'identified' as such right from the start using ... *the PCR test not testing for the 'virus'*. If you are new to this and find that shocking then stick around. I have hardly started yet. Even worse, other 'tests', like the 'Lateral Flow Device' (LFD), are considered so useless that they have to be *confirmed* by the PCR test! Leaked emails written by Ben Dyson, adviser to UK 'Health' Secretary Matt Hancock, said they were 'dangerously unreliable'. Dyson, executive director of strategy at the Department of Health, wrote: 'As of today, someone who gets a positive LFD result in (say) London has at best a 25 per cent chance of it being a true positive, but if it is a self-reported test potentially as low as 10 per cent (on an optimistic assumption about specificity) or as low as 2 per cent (on a more pessimistic assumption).' These are the 'tests' that schoolchildren and the public are being urged to have twice a week or more and have to isolate if they get a positive. Each fake positive goes in the statistics as a 'case' no matter how ludicrously inaccurate and the

'cases' drive lockdown, masks and the pressure to 'vaccinate'. The government said in response to the email leak that the 'tests' were accurate which confirmed yet again what shocking bloody liars they are. The real false positive rate is *100 percent* as we'll see. In another 'you couldn't make it up' the UK government agreed to pay £2.8 billion to California's Innova Medical Group to supply the irrelevant lateral flow tests. The company's primary test-making centre is in China. Innova Medical Group, established in March, 2020, is owned by Pasaca Capital Inc, chaired by Chinese-American millionaire Charles Huang who was born in Wuhan.

### **How it works – and how it doesn't**

The RT-PCR test, known by its full title of Polymerase chain reaction, is used across the world to make millions, even billions, of copies of a DNA/RNA genetic information sample. The process is called 'amplification' and means that a tiny sample of genetic material is amplified to bring out the detailed content. I stress that it is not testing for an infectious disease. It is simply amplifying a sample of genetic material. In the words of Kary Mullis: 'PCR is ... just a process that's used to make a whole lot of something out of something.' To emphasise the point companies that make the PCR tests circulated around the world to 'test' for 'Covid' warn on the box that it can't be used to detect 'Covid' or infectious disease and is for research purposes only. It's okay, rest for a minute and you'll be fine. This is the test that produces the 'cases' and 'deaths' that have been used to destroy human society. All those global and national medical and scientific 'experts' demanding this destruction to 'save us' *KNOW* that the test is not testing for the 'virus' and the cases and deaths they claim to be real are an almost unimaginable fraud. Every one of them and so many others including politicians and psychopaths like Gates and Tedros must be brought before Nuremburg-type trials and jailed for the rest of their lives. The more the genetic sample is amplified by PCR the more elements of that material become sensitive to the test and by that I don't mean sensitive for a 'virus' but for elements of the genetic material which

is *naturally* in the body or relates to remnants of old conditions of various kinds lying dormant and causing no disease. Once the amplification of the PCR reaches a certain level *everyone* will test positive. So much of the material has been made sensitive to the test that everyone will have some part of it in their body. Even lying criminals like Fauci have said that once PCR amplifications pass 35 cycles everything will be a false positive that cannot be trusted for the reasons I have described. I say, like many proper doctors and scientists, that 100 percent of the 'positives' are false, but let's just go with Fauci for a moment.

He says that any amplification over 35 cycles will produce false positives and yet the US Centers for Disease Control (CDC) and Food and Drug Administration (FDA) have recommended up to 40 *cycles* and the National Health Service (NHS) in Britain admitted in an internal document for staff that it was using 45 *cycles* of amplification. A long list of other countries has been doing the same and at least one 'testing' laboratory has been using 50 *cycles*. Have you ever heard a doctor, medical 'expert' or the media ask what level of amplification has been used to claim a 'positive'. The 'test' comes back 'positive' and so you have the 'virus', end of story. Now we can see how the government in Tanzania could send off samples from a goat and a pawpaw fruit under human names and both came back positive for 'Covid-19'. Tanzania president John Magufuli mocked the 'Covid' hysteria, the PCR test and masks and refused to import the DNA-manipulating 'vaccine'. The Cult hated him and an article sponsored by the Bill Gates Foundation appeared in the London *Guardian* in February, 2021, headed 'It's time for Africa to rein in Tanzania's anti-vaxxer president'. Well, 'reined in' he shortly was. Magufuli appeared in good health, but then, in March, 2021, he was dead at 61 from 'heart failure'. He was replaced by Samia Hassan Suhulu who is connected to Klaus Schwab's World Economic Forum and she immediately reversed Magufuli's 'Covid' policy. A sample of cola tested positive for 'Covid' with the PCR test in Germany while American actress and singer-songwriter Erykah Badu tested positive in one nostril and negative in the other. Footballer Ronaldo called



the PCR test 'bullshit' after testing positive three times and being forced to quarantine and miss matches when there was nothing wrong with him. The mantra from Tedros at the World Health Organization and national governments (same thing) has been test, test, test. They know that the more tests they can generate the more fake 'cases' they have which go on to become 'deaths' in ways I am coming to. The UK government has its Operation Moonshot planned to test multiple millions every day in workplaces and schools with free tests for everyone to use twice a week at home in line with the Cult plan from the start to make testing part of life. A government advertisement for an 'Interim Head of Asymptomatic Testing Communication' said the job included responsibility for delivering a 'communications strategy' (propaganda) 'to support the expansion of asymptomatic testing that *'normalises testing as part of everyday life'*'. More tests means more fake 'cases', 'deaths' and fascism. I have heard of, and from, many people who booked a test, couldn't turn up, and yet got a positive result through the post for a test they'd never even had. The whole thing is crazy, but for the Cult there's method in the madness. Controlling and manipulating the level of amplification of the test means the authorities can control whenever they want the number of apparent 'cases' and 'deaths'. If they want to justify more fascist lockdown and destruction of livelihoods they keep the amplification high. If they want to give the illusion that lockdowns and the 'vaccine' are working then they lower the amplification and 'cases' and 'deaths' will appear to fall. In January, 2021, the Cult-owned World Health Organization suddenly warned laboratories about over-amplification of the test and to lower the threshold. Suddenly headlines began appearing such as: 'Why ARE "Covid" cases plummeting?' This was just when the vaccine rollout was underway and I had predicted months before they would make cases appear to fall through amplification tampering when the 'vaccine' came. These people are so predictable.

## **Cow vaccines?**

The question must be asked of what is on the test swabs being poked far up the nose of the population to the base of the brain? A nasal swab punctured one woman's brain and caused it to leak fluid. Most of these procedures are being done by people with little training or medical knowledge. Dr Lorraine Day, former orthopaedic trauma surgeon and Chief of Orthopaedic Surgery at San Francisco General Hospital, says the tests are really a 'vaccine'. Cows have long been vaccinated this way. She points out that masks have to cover the nose and the mouth where it is claimed the 'virus' exists in saliva. Why then don't they take saliva from the mouth as they do with a DNA test instead of pushing a long swab up the nose towards the brain? The ethmoid bone separates the nasal cavity from the brain and within that bone is the cribriform plate. Dr Day says that when the swab is pushed up against this plate and twisted the procedure is 'depositing things back there'. She claims that among these 'things' are nanoparticles that can enter the brain. Researchers have noted that a team at the Gates-funded Johns Hopkins have designed tiny, star-shaped micro-devices that can latch onto intestinal mucosa and release drugs into the body. Mucosa is the thin skin that covers the inside surface of parts of the body such as *the nose* and mouth and produces mucus to protect them. The Johns Hopkins micro-devices are called 'theragrippers' and were 'inspired' by a parasitic worm that digs its sharp teeth into a host's intestines. Nasal swabs are also coated in the sterilisation agent ethylene oxide. The US National Cancer Institute posts this explanation on its website:

At room temperature, ethylene oxide is a flammable colorless gas with a sweet odor. It is used primarily to produce other chemicals, including antifreeze. In smaller amounts, ethylene oxide is used as a pesticide and a sterilizing agent. The ability of ethylene oxide to damage DNA makes it an effective sterilizing agent but also accounts for its cancer-causing activity.

The Institute mentions lymphoma and leukaemia as cancers most frequently reported to be associated with occupational exposure to ethylene oxide along with stomach and breast cancers. How does anyone think this is going to work out with the constant testing

regime being inflicted on adults and children at home and at school that will accumulate in the body anything that's on the swab?

## **Doctors know best**

It is vital for people to realise that 'hero' doctors 'know' only what the Big Pharma-dominated medical authorities tell them to 'know' and if they refuse to 'know' what they are told to 'know' they are out the door. They are mostly not physicians or healers, but repeaters of the official narrative – or else. I have seen alleged professional doctors on British television make shocking statements that we are supposed to take seriously. One called 'Dr' Amir Khan, who is actually telling patients how to respond to illness, said that men could take the birth pill to 'help slow down the effects of Covid-19'. In March, 2021, another ridiculous 'Covid study' by an American doctor proposed injecting men with the female sex hormone progesterone as a 'Covid' treatment. British doctor Nighat Arif told the BBC that face coverings were now going to be part of ongoing normal. Yes, the vaccine protects you, she said (evidence?) ... but the way to deal with viruses in the community was always going to come down to hand washing, face covering and keeping a physical distance. That's not what we were told before the 'vaccine' was circulating. Arif said she couldn't imagine ever again going on the underground or in a lift without a mask. I was just thanking my good luck that she was not my doctor when she said – in March, 2021 – that if 'we are *behaving* and we are doing all the right things' she thought we could 'have our nearest and dearest around us at home ... around *Christmas* and *New Year!* Her patronising delivery was the usual school teacher talking to six-year-olds as she repeated every government talking point and probably believed them all. If we have learned anything from the 'Covid' experience surely it must be that humanity's perception of doctors needs a fundamental rethink. NHS 'doctor' Sara Kayat told her television audience that the 'Covid vaccine' would '100 percent prevent hospitalisation and death'. Not even Big Pharma claimed that. We have to stop taking 'experts' at their word without question when so many of them are

clueless and only repeating the party line on which their careers depend. That is not to say there are not brilliant doctors – there are and I have spoken to many of them since all this began – but you won't see them in the mainstream media or quoted by the psychopaths and yes-people in government.

### **Remember the name – Christian Drosten**

German virologist Christian Drosten, Director of Charité Institute of Virology in Berlin, became a national star after the pandemic hoax began. He was feted on television and advised the German government on 'Covid' policy. Most importantly to the wider world Drosten led a group that produced the 'Covid' testing protocol for the PCR test. What a remarkable feat given the PCR cannot test for infectious disease and even more so when you think that Drosten said that his method of testing for SARS-CoV-2 was developed 'without having virus material available'. *He developed a test for a 'virus' that he didn't have and had never seen.* Let that sink in as you survey the global devastation that came from what he did. The whole catastrophe of Drosten's 'test' was based on the alleged genetic sequence published by Chinese scientists on the Internet. We will see in the next chapter that this alleged 'genetic sequence' has never been produced by China or anyone and cannot be when there *is no* SARS-CoV-2. Drosten, however, doesn't seem to let little details like that get in the way. He was the lead author with Victor Corman from the same Charité Hospital of the paper 'Detection of 2019 novel coronavirus (2019-nCoV) by real-time PCR' published in a magazine called *Eurosurveillance*. This became known as the Corman-Drosten paper. In November, 2020, with human society devastated by the effects of the Corman-Drosten test baloney, the protocol was publicly challenged by 22 international scientists and independent researchers from Europe, the United States, and Japan. Among them were senior molecular geneticists, biochemists, immunologists, and microbiologists. They produced a document headed 'External peer review of the RTPCR test to detect SARS-Cov-2 Reveals 10 Major Flaws At The Molecular and Methodological Level: Consequences

For False-Positive Results'. The flaws in the Corman-Drosten test included the following:

- The test is non-specific because of erroneous design
- Results are enormously variable
- The test is unable to discriminate between the whole 'virus' and viral fragments
- It doesn't have positive or negative controls
- The test lacks a standard operating procedure
- It is unsupported by proper peer view

The scientists said the PCR 'Covid' testing protocol was not founded on science and they demanded the Corman-Drosten paper be retracted by *Eurosurveillance*. They said all present and previous Covid deaths, cases, and 'infection rates' should be subject to a massive retroactive inquiry. Lockdowns and travel restrictions should be reviewed and relaxed and those diagnosed through PCR to have 'Covid-19' should not be forced to isolate. Dr Kevin Corbett, a health researcher and nurse educator with a long academic career producing a stream of peer-reviewed publications at many UK universities, made the same point about the PCR test debacle. He said of the scientists' conclusions: 'Every scientific rationale for the development of that test has been totally destroyed by this paper. It's like Hiroshima/Nagasaki to the Covid test.' He said that China hadn't given them an isolated 'virus' when Drosten developed the test. Instead they had developed the test from *a sequence in a gene bank*.' Put another way ... *they made it up!* The scientists were supported in this contention by a Portuguese appeals court which ruled in November, 2020, that PCR tests are unreliable and it is unlawful to quarantine people based solely on a PCR test. The point about China not providing an isolated virus must be true when the 'virus' has never been isolated to this day and the consequences of that will become clear. Drosten and company produced this useless 'protocol' right on cue in January, 2020, just as the 'virus' was said to

be moving westward and it somehow managed to successfully pass a peer-review in 24 hours. In other words there was no peer-review for a test that would be used to decide who had 'Covid' and who didn't across the world. The Cult-created, Gates-controlled World Health Organization immediately recommended all its nearly 200 member countries to use the Drosten PCR protocol to detect 'cases' and 'deaths'. The sting was underway and it continues to this day.

So who is this Christian Drosten that produced the means through which death, destruction and economic catastrophe would be justified? His education background, including his doctoral thesis, would appear to be somewhat shrouded in mystery and his track record is dire as with another essential player in the 'Covid' hoax, the Gates-funded Professor Neil Ferguson at the Gates-funded Imperial College in London of whom more shortly. Drosten predicted in 2003 that the alleged original SARS 'virus' (SARS-1) was an epidemic that could have serious effects on economies and an effective vaccine would take at least two years to produce. Drosten's answer to every alleged 'outbreak' is a vaccine which you won't be shocked to know. What followed were just 774 official deaths worldwide and none in Germany where there were only nine cases. That is even if you believe there ever was a SARS 'virus' when the evidence is zilch and I will expand on this in the next chapter. Drosten claims to be co-discoverer of 'SARS-1' and developed a test for it in 2003. He was screaming warnings about 'swine flu' in 2009 and how it was a widespread infection far more severe than any dangers from a vaccine could be and people should get vaccinated. It would be helpful for Drosten's vocal chords if he simply recorded the words 'the virus is deadly and you need to get vaccinated' and copies could be handed out whenever the latest made-up threat comes along. Drosten's swine flu epidemic never happened, but Big Pharma didn't mind with governments spending hundreds of millions on vaccines that hardly anyone bothered to use and many who did wished they hadn't. A study in 2010 revealed that the risk of dying from swine flu, or H1N1, was no higher than that of the annual seasonal flu which is what at least most of 'it' really was as in

the case of 'Covid-19'. A media investigation into Drosten asked how with such a record of inaccuracy he could be *the* government adviser on these issues. The answer to that question is the same with Drosten, Ferguson and Fauci – they keep on giving the authorities the 'conclusions' and 'advice' they want to hear. Drosten certainly produced the goods for them in January, 2020, with his PCR protocol garbage and provided the foundation of what German internal medicine specialist Dr Claus Köhnlein, co-author of *Virus Mania*, called the 'test pandemic'. The 22 scientists in the *Eurosurveillance* challenge called out conflicts of interest within the Drosten 'protocol' group and with good reason. Olfert Landt, a regular co-author of Drosten 'studies', owns the biotech company TIB Molbiol Syntheselabor GmbH in Berlin which manufactures and sells the tests that Drosten and his mates come up with. They have done this with SARS, Enterotoxigenic E. coli (ETEC), MERS, Zika 'virus', yellow fever, and now 'Covid'. Landt told the *Berliner Zeitung* newspaper:

The testing, design and development came from the Charité [Drosten and Corman]. We simply implemented it immediately in the form of a kit. And if we don't have the virus, which originally only existed in Wuhan, we can make a synthetic gene to simulate the genome of the virus. That's what we did very quickly.

This is more confirmation that the Drosten test was designed without access to the 'virus' and only a synthetic simulation which is what SARS-CoV-2 really is – a computer-generated synthetic fiction. It's quite an enterprise they have going here. A Drosten team decides what the test for something should be and Landt's biotech company flogs it to governments and medical systems across the world. His company must have made an absolute fortune since the 'Covid' hoax began. Dr Reiner Fuellmich, a prominent German consumer protection trial lawyer in Germany and California, is on Drosten's case and that of Tedros at the World Health Organization for crimes against humanity with a class-action lawsuit being prepared in the United States and other legal action in Germany.

## Why China?

Scamming the world with a 'virus' that doesn't exist would seem impossible on the face of it, but not if you have control of the relatively few people that make policy decisions and the great majority of the global media. Remember it's not about changing 'real' reality it's about controlling *perception* of reality. You don't have to make something happen you only have to make people *believe* that it's happening. Renegade Minds understand this and are therefore much harder to swindle. 'Covid-19' is not a 'real' 'virus'. It's a mind virus, like a computer virus, which has infected the minds, not the bodies, of billions. It all started, publically at least, in China and that alone is of central significance. The Cult was behind the revolution led by its asset Mao Zedong, or Chairman Mao, which established the People's Republic of China on October 1st, 1949. It should have been called The Cult's Republic of China, but the name had to reflect the recurring illusion that vicious dictatorships are run by and for the people (see all the 'Democratic Republics' controlled by tyrants). In the same way we have the 'Biden' Democratic Republic of America officially ruled by a puppet tyrant (at least temporarily) on behalf of Cult tyrants. The creation of Mao's merciless communist/fascist dictatorship was part of a frenzy of activity by the Cult at the conclusion of World War Two which, like the First World War, it had instigated through its assets in Germany, Britain, France, the United States and elsewhere. Israel was formed in 1948; the Soviet Union expanded its 'Iron Curtain' control, influence and military power with the Warsaw Pact communist alliance in 1955; the United Nations was formed in 1945 as a Cult precursor to world government; and a long list of world bodies would be established including the World Health Organization (1948), World Trade Organization (1948 under another name until 1995), International Monetary Fund (1945) and World Bank (1944). Human society was redrawn and hugely centralised in the global Problem-Reaction-Solution that was World War Two. All these changes were significant. Israel would become the headquarters of the Sabbatians



and the revolution in China would prepare the ground and control system for the events of 2019/2020.

Renegade Minds know there are no borders except for public consumption. The Cult is a seamless, borderless global entity and to understand the game we need to put aside labels like borders, nations, countries, communism, fascism and democracy. These delude the population into believing that countries are ruled within their borders by a government of whatever shade when these are mere agencies of a global power. America's illusion of democracy and China's communism/fascism are subsidiaries – vehicles – for the same agenda. We may hear about conflict and competition between America and China and on the lower levels that will be true; but at the Cult level they are branches of the same company in the way of the McDonald's example I gave earlier. I have tracked in the books over the years support by US governments of both parties for Chinese Communist Party infiltration of American society through allowing the sale of land, even military facilities, and the acquisition of American business and university influence. All this is underpinned by the infamous stealing of intellectual property and technological know-how. Cult-owned Silicon Valley corporations waive their fraudulent 'morality' to do business with human-rights-free China; Cult-controlled Disney has become China's PR department; and China in effect owns 'American' sports such as basketball which depends for much of its income on Chinese audiences. As a result any sports player, coach or official speaking out against China's horrific human rights record is immediately condemned or fired by the China-worshipping National Basketball Association. One of the first acts of China-controlled Biden was to issue an executive order telling federal agencies to stop making references to the 'virus' by the 'geographic location of its origin'. Long-time Congressman Jerry Nadler warned that criticising China, America's biggest rival, leads to hate crimes against Asian people in the United States. So shut up you bigot. China is fast closing in on Israel as a country that must not be criticised which is apt, really, given that Sabbatians control them both. The two countries have

developed close economic, military, technological and strategic ties which include involvement in China's 'Silk Road' transport and economic initiative to connect China with Europe. Israel was the first country in the Middle East to recognise the establishment of Mao's tyranny in 1950 months after it was established.

### **Project Wuhan – the 'Covid' Psyop**

I emphasise again that the Cult plays the long game and what is happening to the world today is the result of centuries of calculated manipulation following a script to take control step-by-step of every aspect of human society. I will discuss later the common force behind all this that has spanned those centuries and thousands of years if the truth be told. Instigating the Mao revolution in China in 1949 with a 2020 'pandemic' in mind is not only how they work – the 71 years between them is really quite short by the Cult's standards of manipulation preparation. The reason for the Cult's Chinese revolution was to create a fiercely-controlled environment within which an extreme structure for human control could be incubated to eventually be unleashed across the world. We have seen this happen since the 'pandemic' emerged from China with the Chinese control-structure founded on AI technology and tyrannical enforcement sweep across the West. Until the moment when the Cult went for broke in the West and put its fascism on public display Western governments had to pay some lip-service to freedom and democracy to not alert too many people to the tyranny-in-the-making. Freedoms were more subtly eroded and power centralised with covert government structures put in place waiting for the arrival of 2020 when that smokescreen of 'freedom' could be dispensed with. The West was not able to move towards tyranny before 2020 anything like as fast as China which was created as a tyranny and had no limits on how fast it could construct the Cult's blueprint for global control. When the time came to impose that structure on the world it was the same Cult-owned Chinese communist/fascist government that provided the excuse – the 'Covid pandemic'. It was absolutely crucial to the Cult plan for the Chinese response to the 'pandemic' –

draconian lockdowns of the entire population – to become the blueprint that Western countries would follow to destroy the livelihoods and freedom of their people. This is why the Cult-owned, Gates-owned, WHO Director-General Tedros said early on:

The Chinese government is to be congratulated for the extraordinary measures it has taken to contain the outbreak. China is actually setting a new standard for outbreak response and it is not an exaggeration.

*Forbes* magazine said of China: ‘... those measures protected untold millions from getting the disease’. The Rockefeller Foundation ‘epidemic scenario’ document in 2010 said ‘prophetically’:

However, a few countries did fare better – China in particular. The Chinese government’s quick imposition and enforcement of mandatory quarantine for all citizens, as well as its instant and near-hermetic sealing off of all borders, saved millions of lives, stopping the spread of the virus far earlier than in other countries and enabling a swifter post-pandemic recovery.

Once again – *spooky*.

The first official story was the ‘bat theory’ or rather the bat diversion. The source of the ‘virus outbreak’ we were told was a ‘wet market’ in Wuhan where bats and other animals are bought and eaten in horrifically unhygienic conditions. Then another story emerged through the alternative media that the ‘virus’ had been released on purpose or by accident from a BSL-4 (biosafety level 4) laboratory in Wuhan not far from the wet market. The lab was reported to create and work with lethal concoctions and bioweapons. Biosafety level 4 is the highest in the World Health Organization system of safety and containment. Renegade Minds are aware of what I call designer manipulation. The ideal for the Cult is for people to buy its prime narrative which in the opening salvos of the ‘pandemic’ was the wet market story. It knows, however, that there is now a considerable worldwide alternative media of researchers sceptical of anything governments say and they are often given a version of events in a form they can perceive as credible while misdirecting them from the real truth. In this case let them

think that the conspiracy involved is a 'bioweapon virus' released from the Wuhan lab to keep them from the real conspiracy – *there is no 'virus'*. The WHO's current position on the source of the outbreak at the time of writing appears to be: 'We haven't got a clue, mate.' This is a good position to maintain mystery and bewilderment. The inner circle will know where the 'virus' came from – *nowhere*. The bottom line was to ensure the public believed there *was* a 'virus' and it didn't much matter if they thought it was natural or had been released from a lab. The belief that there was a 'deadly virus' was all that was needed to trigger global panic and fear. The population was terrified into handing their power to authority and doing what they were told. They had to or they were 'all gonna die'.

In March, 2020, information began to come my way from real doctors and scientists and my own additional research which had my intuition screaming: 'Yes, that's it! *There is no virus.*' The 'bioweapon' was not the 'virus'; it was the '*vaccine*' already being talked about that would be the bioweapon. My conclusion was further enhanced by happenings in Wuhan. The 'virus' was said to be sweeping the city and news footage circulated of people collapsing in the street (which they've never done in the West with the same 'virus'). The Chinese government was building 'new hospitals' in a matter of ten days to 'cope with demand' such was the virulent nature of the 'virus'. Yet in what seemed like no time the 'new hospitals' closed – even if they even opened – and China declared itself 'virus-free'. It was back to business as usual. This was more propaganda to promote the Chinese draconian lockdowns in the West as the way to 'beat the virus'. Trouble was that we subsequently had lockdown after lockdown, but never business as usual. As the people of the West and most of the rest of the world were caught in an ever-worsening spiral of lockdown, social distancing, masks, isolated old people, families forced apart, and livelihood destruction, it was party-time in Wuhan. Pictures emerged of thousands of people enjoying pool parties and concerts. It made no sense until you realised there never was a 'virus' and the

whole thing was a Cult set-up to transform human society out of one of its major global strongholds – China.

How is it possible to deceive virtually the entire world population into believing there is a deadly virus when there is not even a 'virus' let alone a deadly one? It's nothing like as difficult as you would think and that's clearly true because it happened.

**Postscript:** See end of book Postscript for more on the 'Wuhan lab virus release' story which the authorities and media were pushing heavily in the summer of 2021 to divert attention from the truth that the 'Covid virus' is pure invention.

## CHAPTER FIVE

### ***There is no 'virus'***

*You can fool some of the people all of the time, and all of the people some of the time, but you cannot fool all of the people all of the time*

Abraham Lincoln

The greatest form of mind control is repetition. The more you repeat the same mantra of alleged 'facts' the more will accept them to be true. It becomes an 'everyone knows that, mate'. If you can also censor any other version or alternative to your alleged 'facts' you are pretty much home and cooking.

By the start of 2020 the Cult owned the global mainstream media almost in its entirety to spew out its 'Covid' propaganda and ignore or discredit any other information and view. Cult-owned social media platforms in Cult-owned Silicon Valley were poised and ready to unleash a campaign of ferocious censorship to obliterate all but the official narrative. To complete the circle many demands for censorship by Silicon Valley were led by the mainstream media as 'journalists' became full-out enforcers for the Cult both as propagandists and censors. Part of this has been the influx of young people straight out of university who have become 'journalists' in significant positions. They have no experience and a headful of programmed perceptions from their years at school and university at a time when today's young are the most perceptually-targeted generations in known human history given the insidious impact of technology. They enter the media perceptually prepared and ready to repeat the narratives of the system that programmed them to

repeat its narratives. The BBC has a truly pathetic 'specialist disinformation reporter' called Marianna Spring who fits this bill perfectly. She is clueless about the world, how it works and what is really going on. Her role is to discredit anyone doing the job that a proper journalist would do and system-serving hacks like Spring wouldn't dare to do or even see the need to do. They are too busy licking the arse of authority which can never be wrong and, in the case of the BBC propaganda programme, *Panorama*, contacting payments systems such as PayPal to have a donations page taken down for a film company making documentaries questioning vaccines. Even the BBC soap opera *EastEnders* included a disgracefully biased scene in which an inarticulate white working class woman was made to look foolish for questioning the 'vaccine' while a well-spoken black man and Asian woman promoted the government narrative. It ticked every BBC box and the fact that the black and minority community was resisting the 'vaccine' had nothing to do with the way the scene was written. The BBC has become a disgusting tyrannical propaganda and censorship operation that should be defunded and disbanded and a free media take its place with a brief to stop censorship instead of demanding it. A BBC 'interview' with Gates goes something like: 'Mr Gates, sir, if I can call you sir, would you like to tell our audience why you are such a great man, a wonderful humanitarian philanthropist, and why you should absolutely be allowed as a software salesman to decide health policy for approaching eight billion people? Thank you, sir, please sir.' Propaganda programming has been incessant and merciless and when all you hear is the same story from the media, repeated by those around you who have only heard the same story, is it any wonder that people on a grand scale believe absolute mendacious garbage to be true? You are about to see, too, why this level of information control is necessary when the official 'Covid' narrative is so nonsensical and unsupportable by the evidence.

## **Structure of Deceit**

The pyramid structure through which the 'Covid' hoax has been manifested is very simple and has to be to work. As few people as possible have to be involved with full knowledge of what they are doing – and why – or the real story would get out. At the top of the pyramid are the inner core of the Cult which controls Bill Gates who, in turn, controls the World Health Organization through his pivotal funding and his puppet Director-General mouthpiece, Tedros. Before he was appointed Tedros was chair of the Gates-founded Global Fund to 'fight against AIDS, tuberculosis and malaria', a board member of the Gates-funded 'vaccine alliance' GAVI, and on the board of another Gates-funded organisation. Gates owns him and picked him for a specific reason – Tedros is a crook and worse. 'Dr' Tedros (he's not a medical doctor, the first WHO chief not to be) was a member of the tyrannical Marxist government of Ethiopia for decades with all its human rights abuses. He has faced allegations of corruption and misappropriation of funds and was exposed three times for covering up cholera epidemics while Ethiopia's health minister. Tedros appointed the mass-murdering genocidal Zimbabwe dictator Robert Mugabe as a WHO goodwill ambassador for public health which, as with Tedros, is like appointing a psychopath to run a peace and love campaign. The move was so ridiculous that he had to drop Mugabe in the face of widespread condemnation. American economist David Steinman, a Nobel peace prize nominee, lodged a complaint with the International Criminal Court in The Hague over alleged genocide by Tedros when he was Ethiopia's foreign minister. Steinman says Tedros was a 'crucial decision maker' who directed the actions of Ethiopia's security forces from 2013 to 2015 and one of three officials in charge when those security services embarked on the 'killing' and 'torturing' of Ethiopians. You can see where Tedros is coming from and it's sobering to think that he has been the vehicle for Gates and the Cult to direct the global response to 'Covid'. Think about that. A psychopathic Cult dictates to psychopath Gates who dictates to psychopath Tedros who dictates how countries of the world must respond to a 'Covid virus' never scientifically shown to exist. At the same time psychopathic Cult-owned Silicon Valley information



giants like Google, YouTube, Facebook and Twitter announced very early on that they would give the Cult/Gates/Tedros/WHO version of the narrative free advertising and censor those who challenged their intelligence-insulting, mendacious story.

The next layer in the global 'medical' structure below the Cult, Gates and Tedros are the chief medical officers and science 'advisers' in each of the WHO member countries which means virtually all of them. Medical officers and arbiters of science (they're not) then take the WHO policy and recommended responses and impose them on their country's population while the political 'leaders' say they are deciding policy (they're clearly not) by 'following the science' on the advice of the 'experts' – the same medical officers and science 'advisers' (dictators). In this way with the rarest of exceptions the entire world followed the same policy of lockdown, people distancing, masks and 'vaccines' dictated by the psychopathic Cult, psychopathic Gates and psychopathic Tedros who we are supposed to believe give a damn about the health of the world population they are seeking to enslave. That, amazingly, is all there is to it in terms of crucial decision-making. Medical staff in each country then follow like sheep the dictates of the shepherds at the top of the national medical hierarchies – chief medical officers and science 'advisers' who themselves follow like sheep the shepherds of the World Health Organization and the Cult. Shepherds at the national level often have major funding and other connections to Gates and his Bill and Melinda Gates Foundation which carefully hands out money like confetti at a wedding to control the entire global medical system from the WHO down.

### **Follow the money**

Christopher Whitty, Chief Medical Adviser to the UK Government at the centre of 'virus' policy, a senior adviser to the government's Scientific Advisory Group for Emergencies (SAGE), and Executive Board member of the World Health Organization, was gifted a grant of \$40 million by the Bill and Melinda Gates Foundation for malaria research in Africa. The BBC described the unelected Whitty as 'the

official who will probably have the greatest impact on our everyday lives of any individual policymaker in modern times' and so it turned out. What Gates and Tedros have said Whitty has done like his equivalents around the world. Patrick Vallance, co-chair of SAGE and the government's Chief Scientific Adviser, is a former executive of Big Pharma giant GlaxoSmithKline with its fundamental financial and business connections to Bill Gates. In September, 2020, it was revealed that Vallance owned a deferred bonus of shares in GlaxoSmithKline worth £600,000 while the company was 'developing' a 'Covid vaccine'. Move along now – nothing to see here – what could possibly be wrong with that? Imperial College in London, a major player in 'Covid' policy in Britain and elsewhere with its 'Covid-19' Response Team, is funded by Gates and has big connections to China while the now infamous Professor Neil Ferguson, the useless 'computer modeller' at Imperial College is also funded by Gates. Ferguson delivered the dramatically inaccurate excuse for the first lockdowns (much more in the next chapter). The Institute for Health Metrics and Evaluation (IHME) in the United States, another source of outrageously false 'Covid' computer models to justify lockdowns, is bankrolled by Gates who is a vehement promotor of lockdowns. America's version of Whitty and Vallance, the again now infamous Anthony Fauci, has connections to 'Covid vaccine' maker Moderna as does Bill Gates through funding from the Bill and Melinda Gates Foundation. Fauci is director of the National Institute of Allergy and Infectious Diseases (NIAID), a major recipient of Gates money, and they are very close. Deborah Birx who was appointed White House Coronavirus Response Coordinator in February, 2020, is yet another with ties to Gates. Everywhere you look at the different elements around the world behind the coordination and decision making of the 'Covid' hoax there is Bill Gates and his money. They include the World Health Organization; Centers for Disease Control (CDC) in the United States; National Institutes of Health (NIH) of Anthony Fauci; Imperial College and Neil Ferguson; the London School of Hygiene where Chris Whitty worked; Regulatory agencies like the UK Medicines & Healthcare products Regulatory Agency (MHRA)

which gave emergency approval for 'Covid vaccines'; Wellcome Trust; GAVI, the Vaccine Alliance; the Coalition for Epidemic Preparedness Innovations (CEPI); Johns Hopkins University which has compiled the false 'Covid' figures; and the World Economic Forum. A [Nationalfile.com](http://Nationalfile.com) article said:

Gates has a lot of pull in the medical world, he has a multi-million dollar relationship with Dr. Fauci, and Fauci originally took the Gates line supporting vaccines and casting doubt on [the drug hydroxychloroquine]. Coronavirus response team member Dr. Deborah Birx, appointed by former president Obama to serve as United States Global AIDS Coordinator, also sits on the board of a group that has received billions from Gates' foundation, and Birx reportedly used a disputed Bill Gates-funded model for the White House's Coronavirus effort. Gates is a big proponent for a population lockdown scenario for the Coronavirus outbreak.

Another funder of Moderna is the Defense Advanced Research Projects Agency (DARPA), the technology-development arm of the Pentagon and one of the most sinister organisations on earth. DARPA had a major role with the CIA covert technology-funding operation In-Q-Tel in the development of Google and social media which is now at the centre of global censorship. Fauci and Gates are extremely close and openly admit to talking regularly about 'Covid' policy, but then why wouldn't Gates have a seat at every national 'Covid' table after his Foundation committed \$1.75 billion to the 'fight against Covid-19'. When passed through our Orwellian Translation Unit this means that he has bought and paid for the Cult-driven 'Covid' response worldwide. Research the major 'Covid' response personnel in your own country and you will find the same Gates funding and other connections again and again. Medical and science chiefs following World Health Organization 'policy' sit atop a medical hierarchy in their country of administrators, doctors and nursing staff. These 'subordinates' are told they must work and behave in accordance with the policy delivered from the 'top' of the national 'health' pyramid which is largely the policy delivered by the WHO which is the policy delivered by Gates and the Cult. The whole 'Covid' narrative has been imposed on medical staff by a climate of fear although great numbers don't even need that to comply. They do so through breathtaking levels of ignorance and

include doctors who go through life simply repeating what Big Pharma and their hierarchical masters tell them to say and believe. No wonder Big Pharma 'medicine' is one of the biggest killers on Planet Earth.

The same top-down system of intimidation operates with regard to the Cult Big Pharma cartel which also dictates policy through national and global medical systems in this way. The Cult and Big Pharma agendas are the same because the former controls and owns the latter. 'Health' administrators, doctors, and nursing staff are told to support and parrot the dictated policy or they will face consequences which can include being fired. How sad it's been to see medical staff meekly repeating and imposing Cult policy without question and most of those who can see through the deceit are only willing to speak anonymously off the record. They know what will happen if their identity is known. This has left the courageous few to expose the lies about the 'virus', face masks, overwhelmed hospitals that aren't, and the dangers of the 'vaccine' that isn't a vaccine. When these medical professionals and scientists, some renowned in their field, have taken to the Internet to expose the truth their articles, comments and videos have been deleted by Cult-owned Facebook, Twitter and YouTube. What a real head-shaker to see YouTube videos with leading world scientists and highly qualified medical specialists with an added link underneath to the notorious Cult propaganda website *Wikipedia* to find the 'facts' about the same subject.

### **HIV – the 'Covid' trial-run**

I'll give you an example of the consequences for health and truth that come from censorship and unquestioning belief in official narratives. The story was told by PCR inventor Kary Mullis in his book *Dancing Naked in the Mind Field*. He said that in 1984 he accepted as just another scientific fact that Luc Montagnier of France's Pasteur Institute and Robert Gallo of America's National Institutes of Health had independently discovered that a 'retrovirus' dubbed HIV (human immunodeficiency virus) caused AIDS. They

were, after all, Mullis writes, specialists in retroviruses. This is how the medical and science pyramids work. Something is announced or *assumed* and then becomes an everybody-knows-that purely through repetition of the assumption as if it is fact. Complete crap becomes accepted truth with no supporting evidence and only repetition of the crap. This is how a 'virus' that doesn't exist became the 'virus' that changed the world. The HIV-AIDS fairy story became a multi-billion pound industry and the media poured out propaganda terrifying the world about the deadly HIV 'virus' that caused the lethal AIDS. By then Mullis was working at a lab in Santa Monica, California, to detect retroviruses with his PCR test in blood donations received by the Red Cross. In doing so he asked a virologist where he could find a reference for HIV being the cause of AIDS. 'You don't need a reference,' the virologist said ... '*Everybody knows it.*' Mullis said he wanted to quote a reference in the report he was doing and he said he felt a little funny about not knowing the source of such an important discovery when everyone else seemed to. The virologist suggested he cite a report by the Centers for Disease Control and Prevention (CDC) on morbidity and mortality. Mullis read the report, but it only said that an organism had been identified and did not say how. The report did not identify the original scientific work. Physicians, however, *assumed* (key recurring theme) that if the CDC was convinced that HIV caused AIDS then proof must exist. Mullis continues:

I did computer searches. Neither Montagnier, Gallo, nor anyone else had published papers describing experiments which led to the conclusion that HIV probably caused AIDS. I read the papers in *Science* for which they had become well known as AIDS doctors, but all they had said there was that they had found evidence of a past infection by something which was probably HIV in some AIDS patients.

They found antibodies. Antibodies to viruses had always been considered evidence of past disease, not present disease. Antibodies signaled that the virus had been defeated. The patient had saved himself. There was no indication in these papers that this virus caused a disease. They didn't show that everybody with the antibodies had the disease. In fact they found some healthy people with antibodies.

Mullis asked why their work had been published if Montagnier and Gallo hadn't really found this evidence, and why had they been fighting so hard to get credit for the discovery? He says he was hesitant to write 'HIV is the probable cause of AIDS' until he found published evidence to support that. 'Tens of thousands of scientists and researchers were spending billions of dollars a year doing research based on this idea,' Mullis writes. 'The reason had to be there somewhere; otherwise these people would not have allowed their research to settle into one narrow channel of investigation.' He said he lectured about PCR at numerous meetings where people were always talking about HIV and he asked them how they knew that HIV was the cause of AIDS:

Everyone said something. Everyone had the answer at home, in the office, in some drawer. They all knew, and they would send me the papers as soon as they got back. But I never got any papers. Nobody ever sent me the news about how AIDS was caused by HIV.

Eventually Mullis was able to ask Montagnier himself about the reference proof when he lectured in San Diego at the grand opening of the University of California AIDS Research Center. Mullis says this was the last time he would ask his question without showing anger. Montagnier said he should reference the CDC report. 'I read it', Mullis said, and it didn't answer the question. 'If Montagnier didn't know the answer who the hell did?' Then one night Mullis was driving when an interview came on National Public Radio with Peter Duesberg, a prominent virologist at Berkeley and a California Scientist of the Year. Mullis says he finally understood why he could not find references that connected HIV to AIDS – *there weren't any!* No one had ever proved that HIV causes AIDS even though it had spawned a multi-billion pound global industry and the media was repeating this as fact every day in their articles and broadcasts terrifying the shit out of people about AIDS and giving the impression that a positive test for HIV (see 'Covid') was a death sentence. Duesberg was a threat to the AIDS gravy train and the agenda that underpinned it. He was therefore abused and castigated after he told the Proceedings of the National Academy of Sciences

there was no good evidence implicating the new 'virus'. Editors rejected his manuscripts and his research funds were deleted. Mullis points out that the CDC has defined AIDS as one of more than 30 diseases *if accompanied* by a positive result on a test that detects antibodies to HIV; but those same diseases are not defined as AIDS cases when antibodies are not detected:

If an HIV-positive woman develops uterine cancer, for example, she is considered to have AIDS. If she is not HIV positive, she simply has uterine cancer. An HIV-positive man with tuberculosis has AIDS; if he tests negative he simply has tuberculosis. If he lives in Kenya or Colombia, where the test for HIV antibodies is too expensive, he is simply presumed to have the antibodies and therefore AIDS, and therefore he can be treated in the World Health Organization's clinic. It's the only medical help available in some places. And it's free, because the countries that support WHO are worried about AIDS.

Mullis accuses the CDC of continually adding new diseases (see ever more 'Covid symptoms') to the grand AIDS definition and of virtually doctoring the books to make it appear as if the disease continued to spread. He cites how in 1993 the CDC enormously broadened its AIDS definition and county health authorities were delighted because they received \$2,500 per year from the Federal government for every reported AIDS case. Ladies and gentlemen, I have just described, via Kary Mullis, the 'Covid pandemic' of 2020 and beyond. Every element is the same and it's been pulled off in the same way by the same networks.

### **The 'Covid virus' exists? Okay – prove it. Er ... still waiting**

What Kary Mullis described with regard to 'HIV' has been repeated with 'Covid'. A claim is made that a new, or 'novel', infection has been found and the entire medical system of the world repeats that as fact exactly as they did with HIV and AIDS. No one in the mainstream asks rather relevant questions such as 'How do you know?' and 'Where is your proof?' The SARS-Cov-2 'virus' and the 'Covid-19 disease' became an overnight 'everybody-knows-that'. The origin could be debated and mulled over, but what you could not suggest was that 'SARS-Cov-2' didn't exist. That would be

ridiculous. 'Everybody knows' the 'virus' exists. Well, I didn't for one along with American proper doctors like Andrew Kaufman and Tom Cowan and long-time American proper journalist Jon Rappaport. We dared to pursue the obvious and simple question: 'Where's the evidence?' The overwhelming majority in medicine, journalism and the general public did not think to ask that. After all, *everyone knew* there was a new 'virus'. Everyone was saying so and I heard it on the BBC. Some would eventually argue that the 'deadly virus' was nothing like as deadly as claimed, but few would venture into the realms of its very existence. Had they done so they would have found that the evidence for that claim had gone AWOL as with HIV causes AIDS. In fact, not even that. For something to go AWOL it has to exist in the first place and scientific proof for a 'SARS-Cov-2' can be filed under nothing, nowhere and zilch.

Dr Andrew Kaufman is a board-certified forensic psychiatrist in New York State, a Doctor of Medicine and former Assistant Professor and Medical Director of Psychiatry at SUNY Upstate Medical University, and Medical Instructor of Hematology and Oncology at the Medical School of South Carolina. He also studied biology at the Massachusetts Institute of Technology (MIT) and trained in Psychiatry at Duke University. Kaufman is retired from allopathic medicine, but remains a consultant and educator on natural healing, I saw a video of his very early on in the 'Covid' hoax in which he questioned claims about the 'virus' in the absence of any supporting evidence and with plenty pointing the other way. I did everything I could to circulate his work which I felt was asking the pivotal questions that needed an answer. I can recommend an excellent pull-together interview he did with the website The Last Vagabond entitled *Dr Andrew Kaufman: Virus Isolation, Terrain Theory and Covid-19* and his website is [andrewkaufmanmd.com](http://andrewkaufmanmd.com). Kaufman is not only a forensic psychiatrist; he is forensic in all that he does. He always reads original scientific papers, experiments and studies instead of second-third-fourth-hand reports about the 'virus' in the media which are repeating the repeated repetition of the narrative. When he did so with the original Chinese 'virus' papers Kaufman



realised that there was no evidence of a 'SARS-Cov-2'. They had never – from the start – shown it to exist and every repeat of this claim worldwide was based on the accepted existence of proof that was nowhere to be found – see Kary Mullis and HIV. Here we go again.

## **Let's postulate**

Kaufman discovered that the Chinese authorities immediately concluded that the cause of an illness that broke out among about 200 initial patients in Wuhan was a 'new virus' when there were no grounds to make that conclusion. The alleged 'virus' was not isolated from other genetic material in their samples and then shown through a system known as Koch's postulates to be the causative agent of the illness. The world was told that the SARS-Cov-2 'virus' caused a disease they called 'Covid-19' which had 'flu-like' symptoms and could lead to respiratory problems and pneumonia. If it wasn't so tragic it would almost be funny. *'Flu-like' symptoms? Pneumonia? Respiratory disease?* What in CHINA and particularly in Wuhan, one of the most polluted cities in the world with a resulting epidemic of respiratory disease?? Three hundred thousand people get pneumonia in China every year and there are nearly a billion cases worldwide of 'flu-like symptoms'. These have a whole range of causes – including pollution in Wuhan – but no other possibility was credibly considered in late 2019 when the world was told there was a new and deadly 'virus'. The global prevalence of pneumonia and 'flu-like systems' gave the Cult networks unlimited potential to re-diagnose these other causes as the mythical 'Covid-19' and that is what they did from the very start. Kaufman revealed how Chinese medical and science authorities (all subordinates to the Cult-owned communist government) took genetic material from the lungs of only a few of the first patients. The material contained their own cells, bacteria, fungi and other microorganisms living in their bodies. The only way you could prove the existence of the 'virus' and its responsibility for the alleged 'Covid-19' was to isolate the virus from all the other material – a process also known as 'purification' – and

then follow the postulates sequence developed in the late 19th century by German physician and bacteriologist Robert Koch which became the 'gold standard' for connecting an alleged causation agent to a disease:

1. The microorganism (bacteria, fungus, virus, etc.) must be present in every case of the disease and all patients must have the same symptoms. It must also *not be present in healthy individuals*.
2. The microorganism must be isolated from the host with the disease. If the microorganism is a bacteria or fungus it must be grown in a pure culture. If it is a virus, it must be purified (i.e. containing no other material except the virus particles) from a clinical sample.
3. The specific disease, with all of its characteristics, must be reproduced when the infectious agent (the purified virus or a pure culture of bacteria or fungi) is inoculated into a healthy, susceptible host.
4. The microorganism must be recoverable from the experimentally infected host as in step 2.

*Not one* of these criteria has been met in the case of 'SARS-Cov-2' and 'Covid-19'. Not ONE. EVER. Robert Koch refers to bacteria and not viruses. What are called 'viral particles' are so minute (hence masks are useless by any definition) that they could only be seen after the invention of the electron microscope in the 1930s and can still only be observed through that means. American bacteriologist and virologist Thomas Milton Rivers, the so-called 'Father of Modern Virology' who was very significantly director of the Rockefeller Institute for Medical Research in the 1930s, developed a less stringent version of Koch's postulates to identify 'virus' causation known as 'Rivers criteria'. 'Covid' did not pass that process either. Some even doubt whether any 'virus' can be isolated from other particles containing genetic material in the Koch method. Freedom of Information requests in many countries asking for scientific proof that the 'Covid virus' has been purified and isolated and shown to exist have all come back with a 'we don't have that' and when this happened with a request to the UK Department of Health they added this comment:

However, outside of the scope of the [Freedom of Information Act] and on a discretionary basis, the following information has been advised to us, which may be of interest. Most infectious diseases are caused by viruses, bacteria or fungi. Some bacteria or fungi have the capacity to grow on their own in isolation, for example in colonies on a petri dish. Viruses are different in that they are what we call 'obligate pathogens' – that is, they cannot survive or reproduce without infecting a host ...

... For some diseases, it is possible to establish causation between a microorganism and a disease by isolating the pathogen from a patient, growing it in pure culture and reintroducing it to a healthy organism. These are known as 'Koch's postulates' and were developed in 1882. However, as our understanding of disease and different disease-causing agents has advanced, these are no longer the method for determining causation [Andrew Kaufman asks why in that case are there two published articles falsely claiming to satisfy Koch's postulates].

It has long been known that viral diseases cannot be identified in this way as viruses cannot be grown in 'pure culture'. When a patient is tested for a viral illness, this is normally done by looking for the presence of antigens, or viral genetic code in a host with molecular biology techniques [Kaufman asks how you could know the origin of these chemicals without having a pure culture for comparison].

For the record 'antigens' are defined so:

Invading microorganisms have antigens on their surface that the human body can recognise as being foreign – meaning not belonging to it. When the body recognises a foreign antigen, lymphocytes (white blood cells) produce antibodies, which are complementary in shape to the antigen.

Notwithstanding that this is open to question in relation to 'SARS-Cov-2' the presence of 'antibodies' can have many causes and they are found in people that are perfectly well. Kary Mullis said: 'Antibodies ... had always been considered evidence of past disease, not present disease.'

### **'Covid' really is a *computer* 'virus'**

Where the UK Department of Health statement says 'viruses' are now 'diagnosed' through a 'viral genetic code in a host with molecular biology techniques', they mean ... *the PCR test* which its inventor said cannot test for infectious disease. They have no credible method of connecting a 'virus' to a disease and we will see that there is no scientific proof that any 'virus' causes any disease or there is any such thing as a 'virus' in the way that it is described. Tenacious Canadian researcher Christine Massey and her team made

some 40 Freedom of Information requests to national public health agencies in different countries asking for proof that SARS-CoV-2 has been isolated and not one of them could supply that information. Massey said of her request in Canada: 'Freedom of Information reveals Public Health Agency of Canada has no record of 'SARS-COV-2' isolation performed by anyone, anywhere, ever.' If you accept the comment from the UK Department of Health it's because they can't isolate a 'virus'. Even so many 'science' papers claimed to have isolated the 'Covid virus' until they were questioned and had to admit they hadn't. A reply from the Robert Koch Institute in Germany was typical: 'I am not aware of a paper which purified isolated SARS-CoV-2.' So what the hell was Christian Drosten and his gang using to design the 'Covid' testing protocol that has produced all the illusory Covid' cases and 'Covid' deaths when the head of the Chinese version of the CDC admitted there was a problem right from the start in that the 'virus' had never been isolated/purified? Breathe deeply: What they are calling 'Covid' is actually created by a *computer program* i.e. *they made it up* – er, that's it. They took lung fluid, with many sources of genetic material, from one single person alleged to be infected with Covid-19 by a PCR test which they *claimed*, without clear evidence, contained a 'virus'. They used several computer programs to create a model of a theoretical virus genome sequence from more than fifty-six million small sequences of RNA, each of an unknown source, assembling them like a puzzle with no known solution. The computer filled in the gaps with sequences from bits in the gene bank to make it look like a bat SARS-like coronavirus! A wave of the magic wand and poof, an *in silico* (computer-generated) genome, a scientific fantasy, was created. UK health researcher Dr Kevin Corbett made the same point with this analogy:

... It's like giving you a few bones and saying that's your fish. It could be any fish. Not even a skeleton. Here's a few fragments of bones. That's your fish ... It's all from gene bank and the bits of the virus sequence that weren't there they made up.

They synthetically created them to fill in the blanks. That's what genetics is; it's a code. So it's ABBCCDDDD and you're missing some what you think is EEE so you put it in. It's all

synthetic. You just manufacture the bits that are missing. This is the end result of the geneticization of virology. This is basically a computer virus.

Further confirmation came in an email exchange between British citizen journalist Frances Leader and the government's Medicines & Healthcare Products Regulatory Agency (the Gates-funded MHRA) which gave emergency permission for untested 'Covid vaccines' to be used. The agency admitted that the 'vaccine' is not based on an isolated 'virus', but comes from a *computer-generated model*. Frances Leader was naturally banned from Cult-owned fascist Twitter for making this exchange public. The process of creating computer-generated alleged 'viruses' is called 'in silico' or 'in silicon' – computer chips – and the term 'in silico' is believed to originate with biological experiments using only a computer in 1989. 'Vaccines' involved with 'Covid' are also produced 'in silico' or by computer not a natural process. If the original 'virus' is nothing more than a made-up computer model how can there be 'new variants' of something that never existed in the first place? They are not new 'variants'; they are new *computer models* only minutely different to the original program and designed to further terrify the population into having the 'vaccine' and submitting to fascism. You want a 'new variant'? Click, click, enter – there you go. Tell the medical profession that you have discovered a 'South African variant', 'UK variants' or a 'Brazilian variant' and in the usual HIV-causes-AIDS manner they will unquestioningly repeat it with no evidence whatsoever to support these claims. They will go on television and warn about the dangers of 'new variants' while doing nothing more than repeating what they have been told to be true and knowing that any deviation from that would be career suicide. Big-time insiders will know it's a hoax, but much of the medical community is clueless about the way they are being played and themselves play the public without even being aware they are doing so. What an interesting 'coincidence' that AstraZeneca and Oxford University were conducting 'Covid vaccine trials' in the three countries – the UK, South Africa and Brazil – where the first three 'variants' were claimed to have 'broken out'.

## **Here's your 'virus' – it's a unicorn**

Dr Andrew Kaufman presented a brilliant analysis describing how the 'virus' was imagined into fake existence when he dissected an article published by *Nature* and written by 19 authors detailing *alleged* 'sequencing of a complete viral genome' of the 'new SARS-CoV-2 virus'. This computer-modelled *in silico* genome was used as a template for all subsequent genome sequencing experiments that resulted in the so-called variants which he said now number more than 6,000. The fake genome was constructed from more than 56 million individual short strands of RNA. Those little pieces were assembled into longer pieces by finding areas of overlapping sequences. The computer programs created over two million possible combinations from which the authors simply chose the longest one. They then compared this to a 'bat virus' and the computer 'alignment' rearranged the sequence and filled in the gaps! They called this computer-generated abomination the 'complete genome'. Dr Tom Cowan, a fellow medical author and collaborator with Kaufman, said such computer-generation constitutes scientific fraud and he makes this superb analogy:

Here is an equivalency: A group of researchers claim to have found a unicorn because they found a piece of a hoof, a hair from a tail, and a snippet of a horn. They then add that information into a computer and program it to re-create the unicorn, and they then claim this computer re-creation is the real unicorn. Of course, they had never actually seen a unicorn so could not possibly have examined its genetic makeup to compare their samples with the actual unicorn's hair, hooves and horn.

The researchers claim they decided which is the real genome of SARS-CoV-2 by 'consensus', sort of like a vote. Again, different computer programs will come up with different versions of the imaginary 'unicorn', so they come together as a group and decide which is the real imaginary unicorn.

This is how the 'virus' that has transformed the world was brought into fraudulent 'existence'. Extraordinary, yes, but as the Nazis said the bigger the lie the more will believe it. Cowan, however, wasn't finished and he went on to identify what he called the real blockbuster in the paper. He quotes this section from a paper written

by virologists and published by the CDC and then explains what it means:

Therefore, we examined the capacity of SARS-CoV-2 to infect and replicate in several common primate and human cell lines, including human adenocarcinoma cells (A549), human liver cells (HUH 7.0), and human embryonic kidney cells (HEK-293T). In addition to Vero E6 and Vero CCL81 cells. ... Each cell line was inoculated at high multiplicity of infection and examined 24h post-infection.

No CPE was observed in any of the cell lines except in Vero cells, which grew to greater than 10 to the 7th power at 24 h post-infection. In contrast, HUH 7.0 and 293T showed only modest viral replication, and A549 cells were incompatible with SARS CoV-2 infection.

Cowan explains that when virologists attempt to prove infection they have three possible 'hosts' or models on which they can test. The first was humans. Exposure to humans was generally not done for ethical reasons and has never been done with SARS-CoV-2 or any coronavirus. The second possible host was animals. Cowan said that forgetting for a moment that they never actually use purified virus when exposing animals they do use solutions that they *claim* contain the virus. Exposure to animals has been done with SARS-CoV-2 in an experiment involving mice and this is what they found: *None of the wild (normal) mice got sick.* In a group of genetically-modified mice, a statistically insignificant number lost weight and had slightly bristled fur, but they experienced nothing like the illness called 'Covid-19'. Cowan said the third method – the one they mostly rely on – is to inoculate solutions they *say* contain the virus onto a variety of tissue cultures. This process had never been shown to kill tissue *unless* the sample material was starved of nutrients and poisoned as *part of the process.* Yes, incredibly, in tissue experiments designed to show the 'virus' is responsible for killing the tissue they starve the tissue of nutrients and add toxic drugs including antibiotics and they do not have control studies to see if it's the starvation and poisoning that is degrading the tissue rather than the 'virus' they allege to be in there somewhere. You want me to pinch you? Yep, I understand. Tom Cowan said this about the whole nonsensical farce as he explains what that quote from the CDC paper really means:

The shocking thing about the above quote is that using their own methods, the virologists found that solutions containing SARS-CoV-2 – even in high amounts – were NOT, I repeat NOT, infective to any of the three human tissue cultures they tested. In plain English, this means they proved, on their terms, that this ‘new coronavirus’ is not infectious to human beings. It is ONLY infective to monkey kidney cells, and only then when you add two potent drugs (gentamicin and amphotericin), known to be toxic to kidneys, to the mix.

My friends, read this again and again. These virologists, published by the CDC, performed a clear proof, on their terms, showing that the SARS-CoV-2 virus is harmless to human beings. That is the only possible conclusion, but, unfortunately, this result is not even mentioned in their conclusion. They simply say they can provide virus stocks cultured only on monkey Vero cells, thanks for coming.

Cowan concluded: ‘If people really understood how this “science” was done, I would hope they would storm the gates and demand honesty, transparency and truth.’ Dr Michael Yeadon, former Vice President and Chief Scientific Adviser at drug giant Pfizer has been a vocal critic of the ‘Covid vaccine’ and its potential for multiple harm. He said in an interview in April, 2021, that ‘not one [vaccine] has the virus. He was asked why vaccines normally using a ‘dead’ version of a disease to activate the immune system were not used for ‘Covid’ and instead we had the synthetic methods of the ‘mRNA Covid vaccine’. Yeadon said that to do the former ‘you’d have to have some of [the virus] wouldn’t you?’ He added: ‘No-one’s got any – seriously.’ Yeadon said that surely they couldn’t have fooled the whole world for a year without having a virus, ‘but oddly enough ask around – no one’s got it’. He didn’t know why with all the ‘great labs’ around the world that the virus had not been isolated – ‘Maybe they’ve been too busy running bad PCR tests and vaccines that people don’t need.’ What is today called ‘science’ is not ‘science’ at all. Science is no longer what is, but whatever people can be manipulated to *believe* that it is. Real science has been hijacked by the Cult to dispense and produce the ‘expert scientists’ and contentions that suit the agenda of the Cult. How big-time this has happened with the ‘Covid’ hoax which is entirely based on fake science delivered by fake ‘scientists’ and fake ‘doctors’. The human-caused climate change hoax is also entirely based on fake science delivered by fake ‘scientists’ and fake ‘climate experts’. In both cases real



scientists, climate experts and doctors have their views suppressed and deleted by the Cult-owned science establishment, media and Silicon Valley. This is the 'science' that politicians claim to be 'following' and a common denominator of 'Covid' and climate are Cult psychopaths Bill Gates and his mate Klaus Schwab at the Gates-funded World Economic Forum. But, don't worry, it's all just a coincidence and absolutely nothing to worry about. Zzzzzzzzz.

## **What is a 'virus' REALLY?**

Dr Tom Cowan is one of many contesting the very existence of viruses let alone that they cause disease. This is understandable when there is no scientific evidence for a disease-causing 'virus'. German virologist Dr Stefan Lanka won a landmark case in 2017 in the German Supreme Court over his contention that there is no such thing as a measles virus. He had offered a big prize for anyone who could prove there is and Lanka won his case when someone sought to claim the money. There is currently a prize of more than 225,000 euros on offer from an Isolate Truth Fund for anyone who can prove the isolation of SARS-CoV-2 and its genetic substance. Lanka wrote in an article headed 'The Misconception Called Virus' that scientists think a 'virus' is causing tissue to become diseased and degraded when in fact it is the *processes they are using* which do that – not a 'virus'. Lanka has done an important job in making this point clear as Cowan did in his analysis of the CDC paper. Lanka says that all claims about viruses as disease-causing pathogens are wrong and based on 'easily recognisable, understandable and verifiable misinterpretations.' Scientists believed they were working with 'viruses' in their laboratories when they were really working with 'typical particles of specific dying tissues or cells ...' Lanka said that the tissue decaying process claimed to be caused by a 'virus' still happens when no alleged 'virus' is involved. It's the *process* that does the damage and not a 'virus'. The genetic sample is deprived of nutrients, removed from its energy supply through removal from the body and then doused in toxic antibiotics to remove any bacteria. He confirms again that establishment scientists do not (pinch me)

conduct control experiments to see if this is the case and if they did they would see the claims that 'viruses' are doing the damage is nonsense. He adds that during the measles 'virus' court case he commissioned an independent laboratory to perform just such a control experiment and the result was that the tissues and cells died in the exact same way as with alleged 'infected' material. This is supported by a gathering number of scientists, doctors and researchers who reject what is called 'germ theory' or the belief in the body being infected by contagious sources emitted by other people. Researchers Dawn Lester and David Parker take the same stance in their highly-detailed and sourced book *What Really Makes You Ill – Why everything you thought you knew about disease is wrong* which was recommended to me by a number of medical professionals genuinely seeking the truth. Lester and Parker say there is no provable scientific evidence to show that a 'virus' can be transmitted between people or people and animals or animals and people:

The definition also claims that viruses are the cause of many diseases, as if this has been definitively proven. But this is not the case; there is no original scientific evidence that definitively demonstrates that any virus is the cause of any disease. The burden of proof for any theory lies with those who proposed it; but none of the existing documents provides 'proof' that supports the claim that 'viruses' are pathogens.

Dr Tom Cowan employs one of his clever analogies to describe the process by which a 'virus' is named as the culprit for a disease when what is called a 'virus' is only material released by cells detoxing themselves from infiltration by chemical or radiation poisoning. The tidal wave of technologically-generated radiation in the 'smart' modern world plus all the toxic food and drink are causing this to happen more than ever. Deluded 'scientists' misread this as a gathering impact of what they wrongly label 'viruses'.

### **Paper can infect houses**

Cowan said in an article for [davidicke.com](http://davidicke.com) – with his tongue only mildly in his cheek – that he believed he had made a tremendous

discovery that may revolutionise science. He had discovered that small bits of paper are alive, 'well alive-ish', can 'infect' houses, and then reproduce themselves inside the house. The result was that this explosion of growth in the paper inside the house causes the house to explode, blowing it to smithereens. His evidence for this new theory is that in the past months he had carefully examined many of the houses in his neighbourhood and found almost no scraps of paper on the lawns and surrounds of the house. There was an occasional stray label, but nothing more. Then he would return to these same houses a week or so later and with a few, not all of them, particularly the old and decrepit ones, he found to his shock and surprise they were littered with stray bits of paper. He knew then that the paper had infected these houses, made copies of itself, and blew up the house. A young boy on a bicycle at one of the sites told him he had seen a demolition crew using dynamite to explode the house the previous week, but Cowan dismissed this as the idle thoughts of silly boys because 'I was on to something big'. He was on to how 'scientists' mistake genetic material in the detoxifying process for something they call a 'virus'. Cowan said of his house and paper story:

If this sounds crazy to you, it's because it should. This scenario is obviously nuts. But consider this admittedly embellished, for effect, current viral theory that all scientists, medical doctors and virologists currently believe.

He takes the example of the 'novel SARS-Cov2' virus to prove the point. First they take someone with an undefined illness called 'Covid-19' and don't even attempt to find any virus in their sputum. Never mind the scientists still describe how this 'virus', which they have not located attaches to a cell receptor, injects its genetic material, in 'Covid's' case, RNA, into the cell. The RNA once inserted exploits the cell to reproduce itself and makes 'thousands, nay millions, of copies of itself ... Then it emerges victorious to claim its next victim':

If you were to look in the scientific literature for proof, actual scientific proof, that uniform SARS-CoV2 viruses have been properly isolated from the sputum of a sick person, that actual spike proteins could be seen protruding from the virus (which has not been found), you would find that such evidence doesn't exist.

If you go looking in the published scientific literature for actual pictures, proof, that these spike proteins or any viral proteins are ever attached to any receptor embedded in any cell membrane, you would also find that no such evidence exists. If you were to look for a video or documented evidence of the intact virus injecting its genetic material into the body of the cell, reproducing itself and then emerging victorious by budding off the cell membrane, you would find that no such evidence exists.

The closest thing you would find is electron micrograph pictures of cellular particles, possibly attached to cell debris, both of which to be seen were stained by heavy metals, a process that completely distorts their architecture within the living organism. This is like finding bits of paper stuck to the blown-up bricks, thereby proving the paper emerged by taking pieces of the bricks on its way out.

## **The Enders baloney**

Cowan describes the 'Covid' story as being just as make-believe as his paper story and he charts back this fantasy to a Nobel Prize winner called John Enders (1897-1985), an American biomedical scientist who has been dubbed 'The Father of Modern Vaccines'. Enders is claimed to have 'discovered' the process of the viral culture which 'proved' that a 'virus' caused measles. Cowan explains how Enders did this 'by using the EXACT same procedure that has been followed by every virologist to find and characterize every new virus since 1954'. Enders took throat swabs from children with measles and immersed them in 2ml of milk. Penicillin (100u/ml) and the antibiotic streptomycin (50,g/ml) were added and the whole mix was centrifuged – rotated at high speed to separate large cellular debris from small particles and molecules as with milk and cream, for example. Cowan says that if the aim is to find little particles of genetic material ('viruses') in the snot from children with measles it would seem that the last thing you would do is mix the snot with other material – milk –that also has genetic material. 'How are you ever going to know whether whatever you found came from the snot or the milk?' He points out that streptomycin is a 'nephrotoxic' or poisonous-to-the-kidney drug. You will see the relevance of that

shortly. Cowan says that it gets worse, much worse, when Enders describes the culture medium upon which the virus 'grows': 'The culture medium consisted of bovine amniotic fluid (90%), beef embryo extract (5%), horse serum (5%), antibiotics and phenol red as an indicator of cell metabolism.' Cowan asks incredulously: 'Did he just say that the culture medium also contained fluids and tissues that are themselves rich sources of genetic material?' The genetic cocktail, or 'medium', is inoculated onto tissue and cells from rhesus monkey *kidney* tissue. This is where the importance of streptomycin comes in and currently-used antimicrobials and other drugs that are *poisonous to kidneys* and used in ALL modern viral cultures (e.g. gentamicin, streptomycin, and amphotericin). Cowan asks: 'How are you ever going to know from this witch's brew where any genetic material comes from as we now have five different sources of rich genetic material in our mix?' Remember, he says, that all genetic material, whether from monkey kidney tissues, bovine serum, milk, etc., is made from the exact same components. The same central question returns: 'How are you possibly going to know that it was the virus that killed the kidney tissue and not the toxic antibiotic and starvation rations on which you are growing the tissue?' John Enders answered the question himself – *you can't*:

A second agent was obtained from an uninoculated culture of monkey kidney cells. The cytopathic changes [death of the cells] it induced in the unstained preparations could not be distinguished with confidence from the viruses isolated from measles.

The death of the cells ('cytopathic changes') happened in exactly the same manner, whether they inoculated the kidney tissue with the measles snot or not, Cowan says. 'This is evidence that the destruction of the tissue, the very proof of viral causation of illness, was not caused by anything in the snot because they saw the same destructive effect when the snot was not even used ... the cytopathic, i.e., cell-killing, changes come from the process of the culture itself, not from any virus in any snot, period.' Enders quotes in his 1957 paper a virologist called Ruckle as reporting similar findings 'and in addition has isolated an agent from monkey kidney tissue that is so

far indistinguishable from human measles virus'. In other words, Cowan says, these particles called 'measles viruses' are simply and clearly breakdown products of the starved and poisoned tissue. For measles 'virus' see all 'viruses' including the so-called 'Covid virus'. Enders, the 'Father of Modern Vaccines', also said:

There is a potential risk in employing cultures of primate cells for the production of vaccines composed of attenuated virus, since the presence of other agents possibly latent in primate tissues cannot be definitely excluded by any known method.

Cowan further quotes from a paper published in the journal *Viruses* in May, 2020, while the 'Covid pandemic' was well underway in the media if not in reality. 'EVs' here refers to particles of genetic debris from our own tissues, such as exosomes of which more in a moment: 'The remarkable resemblance between EVs and viruses has caused quite a few problems in the studies focused on the analysis of EVs released during viral infections.' Later the paper adds that to date a reliable method that can actually guarantee a complete separation (of EVs from viruses) DOES NOT EXIST. This was published at a time when a fairy tale 'virus' was claimed in total certainty to be causing a fairy tale 'viral disease' called 'Covid-19' – a fairy tale that was already well on the way to transforming human society in the image that the Cult has worked to achieve for so long. Cowan concludes his article:

To summarize, there is no scientific evidence that pathogenic viruses exist. What we think of as 'viruses' are simply the normal breakdown products of dead and dying tissues and cells. When we are well, we make fewer of these particles; when we are starved, poisoned, suffocated by wearing masks, or afraid, we make more.

There is no engineered virus circulating and making people sick. People in laboratories all over the world are making genetically modified products to make people sick. These are called vaccines. There is no virome, no 'ecosystem' of viruses, viruses are not 8%, 50% or 100 % of our genetic material. These are all simply erroneous ideas based on the misconception called a virus.

## **What is 'Covid'? Load of bollocks**

The background described here by Cowan and Lanka was emphasised in the first video presentation that I saw by Dr Andrew Kaufman when he asked whether the 'Covid virus' was in truth a natural defence mechanism of the body called 'exosomes'. These are released by cells when in states of toxicity – see the same themes returning over and over. They are released ever more profusely as chemical and radiation toxicity increases and think of the potential effect therefore of 5G alone as its destructive frequencies infest the human energetic information field with a gathering pace (5G went online in Wuhan in 2019 as the 'virus' emerged). I'll have more about this later. Exosomes transmit a warning to the rest of the body that 'Houston, we have a problem'. Kaufman presented images of exosomes and compared them with 'Covid' under an electron microscope and the similarity was remarkable. They both attach to the same cell receptors (*claimed* in the case of 'Covid'), contain the same genetic material in the form of RNA or ribonucleic acid, and both are found in 'viral cell cultures' with damaged or dying cells. James Hildreth MD, President and Chief Executive Officer of the Meharry Medical College at Johns Hopkins, said: 'The virus is fully an exosome in every sense of the word.' Kaufman's conclusion was that there is no 'virus': 'This entire pandemic is a completely manufactured crisis ... there is no evidence of anyone dying from [this] illness.' Dr Tom Cowan and Sally Fallon Morell, authors of *The Contagion Myth*, published a statement with Dr Kaufman in February, 2021, explaining why the 'virus' does not exist and you can read it that in full in the Appendix.

'Virus' theory can be traced to the 'cell theory' in 1858 of German physician Rudolf Virchow (1821-1920) who contended that disease originates from a single cell infiltrated by a 'virus'. Dr Stefan Lanka said that findings and insights with respect to the structure, function and central importance of tissues in the creation of life, which were already known in 1858, comprehensively refute the cell theory. Virchow ignored them. We have seen the part later played by John Enders in the 1950s and Lanka notes that infection theories were only established as a global dogma through the policies and

eugenics of the Third Reich in Nazi Germany (creation of the same Sabbatian cult behind the 'Covid' hoax). Lanka said: 'Before 1933, scientists dared to contradict this theory; after 1933, these critical scientists were silenced'. Dr Tom Cowan's view is that ill-health is caused by too much of something, too little of something, or toxification from chemicals and radiation – not contagion. We must also highlight as a major source of the 'virus' theology a man still called the 'Father of Modern Virology' – Thomas Milton Rivers (1888-1962). There is no way given the Cult's long game policy that it was a coincidence for the 'Father of Modern Virology' to be director of the Rockefeller Institute for Medical Research from 1937 to 1956 when he is credited with making the Rockefeller Institute a leader in 'viral research'. Cult Rockefeller were the force behind the creation of Big Pharma 'medicine', established the World Health Organisation in 1948, and have long and close associations with the Gates family that now runs the WHO during the pandemic hoax through mega-rich Cult gofer and psychopath Bill Gates.

Only a Renegade Mind can see through all this bullshit by asking the questions that need to be answered, not taking 'no' or prevarication for an answer, and certainly not hiding from the truth in fear of speaking it. Renegade Minds have always changed the world for the better and they will change this one no matter how bleak it may currently appear to be.



## CHAPTER SIX

### **Sequence of deceit**

*If you tell the truth, you don't have to remember anything*  
Mark Twain

**A**gainst the background that I have laid out this far the sequence that took us from an invented 'virus' in Cult-owned China in late 2019 to the fascist transformation of human society can be seen and understood in a whole new context.

We were told that a deadly disease had broken out in Wuhan and the world media began its campaign (coordinated by behavioural psychologists as we shall see) to terrify the population into unquestioning compliance. We were shown images of Chinese people collapsing in the street which never happened in the West with what was supposed to be the same condition. In the earliest days when alleged cases and deaths were few the fear register was hysterical in many areas of the media and this would expand into the common media narrative across the world. The real story was rather different, but we were never told that. The Chinese government, one of the Cult's biggest centres of global operation, said they had discovered a new illness with flu-like and pneumonia-type symptoms in a city with such toxic air that it is overwhelmed with flu-like symptoms, pneumonia and respiratory disease. Chinese scientists said it was a new – 'novel' – coronavirus which they called Sars-Cov-2 and that it caused a disease they labelled 'Covid-19'. There was no evidence for this and the 'virus' has never to this day been isolated, purified and its genetic code established from that. It

was from the beginning a computer-generated fiction. Stories of Chinese whistleblowers saying the number of deaths was being suppressed or that the 'new disease' was related to the Wuhan bio-lab misdirected mainstream and alternative media into cul-de-sacs to obscure the real truth – there was no 'virus'.

Chinese scientists took genetic material from the lung fluid of just a few people and said they had found a 'new' disease when this material had a wide range of content. There was no evidence for a 'virus' for the very reasons explained in the last two chapters. The 'virus' has never been shown to (a) exist and (b) cause any disease. People were diagnosed on symptoms that are so widespread in Wuhan and polluted China and with a PCR test that can't detect infectious disease. On this farce the whole global scam was sold to the rest of the world which would also diagnose respiratory disease as 'Covid-19' from symptoms alone or with a PCR test not testing for a 'virus'. Flu miraculously disappeared *worldwide* in 2020 and into 2021 as it was redesignated 'Covid-19'. It was really the same old flu with its 'flu-like' symptoms attributed to 'flu-like' 'Covid-19'. At the same time with very few exceptions the Chinese response of draconian lockdown and fascism was the chosen weapon to respond across the West as recommended by the Cult-owned Tedros at the Cult-owned World Health Organization run by the Cult-owned Gates. All was going according to plan. Chinese scientists – everything in China is controlled by the Cult-owned government – compared their contaminated RNA lung-fluid material with other RNA sequences and said it appeared to be just under 80 percent identical to the SARS-CoV-1 'virus' claimed to be the cause of the SARS (severe acute respiratory syndrome) 'outbreak' in 2003. They decreed that because of this the 'new virus' had to be related and they called it SARS-CoV-2. There are some serious problems with this assumption and *assumption* was all it was. Most 'factual' science turns out to be assumptions repeated into everyone-knows-that. A match of under 80-percent is meaningless. Dr Kaufman makes the point that there's a 96 percent genetic correlation between humans and chimpanzees, but 'no one would say our genetic material is part

of the chimpanzee family'. Yet the Chinese authorities were claiming that a much lower percentage, less than 80 percent, proved the existence of a new 'coronavirus'. For goodness sake human DNA is 60 percent similar to a *banana*.

## **You are feeling sleepy**

The entire 'Covid' hoax is a global Psyop, a psychological operation to program the human mind into believing and fearing a complete fantasy. A crucial aspect of this was what *appeared* to happen in Italy. It was all very well streaming out daily images of an alleged catastrophe in Wuhan, but to the Western mind it was still on the other side of the world in a very different culture and setting. A reaction of 'this could happen to me and my family' was still nothing like as intense enough for the mind-doctors. The Cult needed a Western example to push people over that edge and it chose Italy, one of its major global locations going back to the Roman Empire. An Italian 'Covid' crisis was manufactured in a particular area called Lombardy which just happens to be notorious for its toxic air and therefore respiratory disease. Wuhan, China, *déjà vu*. An hysterical media told horror stories of Italians dying from 'Covid' in their droves and how Lombardy hospitals were being overrun by a tidal wave of desperately ill people needing treatment after being struck down by the 'deadly virus'. Here was the psychological turning point the Cult had planned. Wow, if this is happening in Italy, the Western mind concluded, this indeed could happen to me and my family. Another point is that Italian authorities responded by following the Chinese blueprint so vehemently recommended by the Cult-owned World Health Organization. They imposed fascistic lockdowns on the whole country viciously policed with the help of surveillance drones sweeping through the streets seeking out anyone who escaped from mass house arrest. Livelihoods were destroyed and psychology unravelled in the way we have witnessed since in all lockdown countries. Crucial to the plan was that Italy responded in this way to set the precedent of suspending freedom and imposing fascism in a 'Western liberal democracy'. I emphasised in an

animated video explanation on [davidicke.com](http://davidicke.com) posted in the summer of 2020 how important it was to the Cult to expand the Chinese lockdown model across the West. Without this, and the bare-faced lie that non-symptomatic people could still transmit a 'disease' they didn't have, there was no way locking down the whole population, sick and not sick, could be pulled off. At just the right time and with no evidence Cult operatives and gofers claimed that people without symptoms could pass on the 'disease'. In the name of protecting the 'vulnerable' like elderly people, who lockdowns would kill by the tens of thousands, we had for the first time healthy people told to isolate as well as the sick. The great majority of people who tested positive had no symptoms because there was nothing wrong with them. It was just a trick made possible by a test not testing for the 'virus'.

Months after my animated video the Gates-funded Professor Neil Ferguson at the Gates-funded Imperial College confirmed that I was right. He didn't say it in those terms, naturally, but he did say it. Ferguson will enter the story shortly for his outrageously crazy 'computer models' that led to Britain, the United States and many other countries following the Chinese and now Italian methods of response. Put another way, following the Cult script. Ferguson said that SAGE, the UK government's scientific advisory group which has controlled 'Covid' policy from the start, wanted to follow the Chinese lockdown model (while they all continued to work and be paid), but they wondered if they could possibly, in Ferguson's words, 'get away with it in Europe'. 'Get away with it'? Who the hell do these moronic, arrogant people think they are? This appalling man Ferguson said that once Italy went into national lockdown they realised they, too, could mimic China:

It's a communist one-party state, we said. We couldn't get away with it in Europe, we thought ... and then Italy did it. And we realised we could. Behind this garbage from Ferguson is a simple fact: Doing the same as China in every country was the plan from the start and Ferguson's 'models' would play a central role in achieving that. It's just a coincidence, of course, and absolutely nothing to worry your little head about.

## **Oops, sorry, our mistake**

Once the Italian segment of the Psyop had done the job it was designed to do a very different story emerged. Italian authorities revealed that 99 percent of those who had 'died from Covid-19' in Italy had one, two, three, or more 'co-morbidities' or illnesses and health problems that could have ended their life. The US Centers for Disease Control and Prevention (CDC) published a figure of 94 percent for Americans dying of 'Covid' while having other serious medical conditions – on average two to three (some five or six) other potential causes of death. In terms of death from an unproven 'virus' I say it is 100 percent. The other one percent in Italy and six percent in the US would presumably have died from 'Covid's' flu-like symptoms with a range of other possible causes in conjunction with a test not testing for the 'virus'. Fox News reported that even more startling figures had emerged in one US county in which 410 of 422 deaths attributed to 'Covid-19' had other potentially deadly health conditions. The Italian National Health Institute said later that the average age of people dying with a 'Covid-19' diagnosis in Italy was about 81. Ninety percent were over 70 with ten percent over 90. In terms of other reasons to die some 80 percent had two or more chronic diseases with half having three or more including cardiovascular problems, diabetes, respiratory problems and cancer. Why is the phantom 'Covid-19' said to kill overwhelmingly old people and hardly affect the young? Old people continually die of many causes and especially respiratory disease which you can re-diagnose 'Covid-19' while young people die in tiny numbers by comparison and rarely of respiratory disease. Old people 'die of Covid' because they die of other things that can be redesignated 'Covid' and it really is that simple.

## **Flu has flown**

The blueprint was in place. Get your illusory 'cases' from a test not testing for the 'virus' and redesignate other causes of death as 'Covid-19'. You have an instant 'pandemic' from something that is nothing more than a computer-generated fiction. With near-on a

billion people having 'flu-like' symptoms every year the potential was limitless and we can see why flu quickly and apparently miraculously disappeared *worldwide* by being diagnosed 'Covid-19'. The painfully bloody obvious was explained away by the childlike media in headlines like this in the UK '*Independent*': 'Not a single case of flu detected by Public Health England this year as Covid restrictions suppress virus'. I kid you not. The masking, social distancing and house arrest that did not make the 'Covid virus' disappear somehow did so with the 'flu virus'. Even worse the article, by a bloke called Samuel Lovett, suggested that maybe the masking, sanitising and other 'Covid' measures should continue to keep the flu away. With a ridiculousness that disturbs your breathing (it's 'Covid-19') the said Lovett wrote: 'With widespread social distancing and mask-wearing measures in place throughout the UK, the usual routes of transmission for influenza have been blocked.' He had absolutely no evidence to support that statement, but look at the consequences of him acknowledging the obvious. With flu not disappearing at all and only being relabelled 'Covid-19' he would have to contemplate that 'Covid' was a hoax on a scale that is hard to imagine. You need guts and commitment to truth to even go there and that's clearly something Samuel Lovett does not have in abundance. He would never have got it through the editors anyway.

Tens of thousands die in the United States alone every winter from flu including many with pneumonia complications. CDC figures record *45 million* Americans diagnosed with flu in 2017-2018 of which 61,000 died and some reports claim 80,000. Where was the same hysteria then that we have seen with 'Covid-19'? Some 250,000 Americans are admitted to hospital with pneumonia every year with about 50,000 cases proving fatal. About 65 million suffer respiratory disease every year and three million deaths makes this the third biggest cause of death worldwide. You only have to redesignate a portion of all these people 'Covid-19' and you have an instant global pandemic or the *appearance* of one. Why would doctors do this? They are told to do this and all but a few dare not refuse those who must be obeyed. Doctors in general are not researching their own

knowledge and instead take it direct and unquestioned from the authorities that own them and their careers. The authorities say they must now diagnose these symptoms 'Covid-19' and not flu, or whatever, and they do it. Dark suits say put 'Covid-19' on death certificates no matter what the cause of death and the doctors do it. Renegade Minds don't fall for the illusion that doctors and medical staff are all highly-intelligent, highly-principled, seekers of medical truth. *Some are*, but not the majority. They are repeaters, gofers, and yes sir, no sir, purveyors of what the system demands they purvey. The 'Covid' con is not merely confined to diseases of the lungs. Instructions to doctors to put 'Covid-19' on death certificates for anyone dying of *anything* within 28 days (or much more) of a positive test not testing for the 'virus' opened the floodgates. The term dying *with* 'Covid' and not *of* 'Covid' was coined to cover the truth. Whether it was a *with* or an *of* they were all added to the death numbers attributed to the 'deadly virus' compiled by national governments and globally by the Gates-funded Johns Hopkins operation in the United States that was so involved in those 'pandemic' simulations. Fraudulent deaths were added to the ever-growing list of fraudulent 'cases' from false positives from a false test. No wonder Professor Walter Ricciardi, scientific advisor to the Italian minister of health, said after the Lombardy hysteria had done its job that 'Covid' death rates were due to Italy having the second oldest population in the world and to *how hospitals record deaths*:

The way in which we code deaths in our country is very generous in the sense that all the people who die in hospitals with the coronavirus are deemed to be dying of the coronavirus. On re-evaluation by the National Institute of Health, only 12 per cent of death certificates have shown a direct causality from coronavirus, while 88 per cent of patients who have died have at least one pre-morbidity – many had two or three.

This is extraordinary enough when you consider the propaganda campaign to use Italy to terrify the world, but how can they even say twelve percent were genuine when the 'virus' has not been shown to exist, its 'code' is a computer program, and diagnosis comes from a test not testing for it? As in China, and soon the world, 'Covid-19' in

Italy was a redesignation of diagnosis. Lies and corruption were to become the real 'pandemic' fuelled by a pathetically-compliant medical system taking its orders from the tiny few at the top of their national hierarchy who answered to the World Health Organization which answers to Gates and the Cult. Doctors were told – ordered – to diagnose a particular set of symptoms 'Covid-19' and put that on the death certificate for any cause of death if the patient had tested positive with a test not testing for the virus or had 'Covid' symptoms like the flu. The United States even introduced big financial incentives to manipulate the figures with hospitals receiving £4,600 from the Medicare system for diagnosing someone with regular pneumonia, \$13,000 if they made the diagnosis from the same symptoms 'Covid-19' pneumonia, and \$39,000 if they put a 'Covid' diagnosed patient on a ventilator that would almost certainly kill them. A few – painfully and pathetically few – medical whistleblowers revealed (before Cult-owned YouTube deleted their videos) that they had been instructed to 'let the patient crash' and put them straight on a ventilator instead of going through a series of far less intrusive and dangerous methods as they would have done before the pandemic hoax began and the financial incentives kicked in. We are talking cold-blooded murder given that ventilators are so damaging to respiratory systems they are usually the last step before heaven awaits. Renegade Minds never fall for the belief that people in white coats are all angels of mercy and cannot be full-on psychopaths. I have explained in detail in *The Answer* how what I am describing here played out across the world coordinated by the World Health Organization through the medical hierarchies in almost every country.

### **Medical scientist calls it**

Information about the non-existence of the 'virus' began to emerge for me in late March, 2020, and mushroomed after that. I was sent an email by Sir Julian Rose, a writer, researcher, and organic farming promotor, from a medical scientist friend of his in the United States. Even at that early stage in March the scientist was able to explain



how the 'Covid' hoax was being manipulated. He said there were no reliable tests for a specific 'Covid-19 virus' and nor were there any reliable agencies or media outlets for reporting numbers of actual 'Covid-19' cases. We have seen in the long period since then that he was absolutely right. 'Every action and reaction to Covid-19 is based on totally flawed data and we simply cannot make accurate assessments,' he said. Most people diagnosed with 'Covid-19' were showing nothing more than cold and flu-like symptoms 'because most coronavirus strains *are* nothing more than cold/flu-like symptoms'. We had farcical situations like an 84-year-old German man testing positive for 'Covid-19' and his nursing home ordered to quarantine only for him to be found to have a common cold. The scientist described back then why PCR tests and what he called the 'Mickey Mouse test kits' were useless for what they were claimed to be identifying. 'The idea these kits can isolate a specific virus like Covid-19 is nonsense,' he said. Significantly, he pointed out that 'if you want to create a totally false panic about a totally false pandemic – pick a coronavirus'. This is exactly what the Cult-owned Gates, World Economic Forum and Johns Hopkins University did with their Event 201 'simulation' followed by their real-life simulation called the 'pandemic'. The scientist said that all you had to do was select the sickest of people with respiratory-type diseases in a single location – 'say Wuhan' – and administer PCR tests to them. You can then claim that anyone showing 'viral sequences' similar to a coronavirus 'which will inevitably be quite a few' is suffering from a 'new' disease:

Since you already selected the sickest flu cases a fairly high proportion of your sample will go on to die. You can then say this 'new' virus has a CFR [case fatality rate] higher than the flu and use this to infuse more concern and do more tests which will of course produce more 'cases', which expands the testing, which produces yet more 'cases' and so on and so on. Before long you have your 'pandemic', and all you have done is use a simple test kit trick to convert the worst flu and pneumonia cases into something new that doesn't ACTUALLY EXIST [my emphasis].

He said that you then 'just run the same scam in other countries' and make sure to keep the fear message running high 'so that people

will feel panicky and less able to think critically'. The only problem to overcome was the fact *there is no* actual new deadly pathogen and only regular sick people. This meant that deaths from the 'new deadly pathogen' were going to be way too low for a real new deadly virus pandemic, but he said this could be overcome in the following ways – all of which would go on to happen:

1. You can claim this is just the beginning and more deaths are imminent [you underpin this with fantasy 'computer projections']. Use this as an excuse to quarantine everyone and then claim the quarantine prevented the expected millions of dead.
2. You can [say that people] 'minimizing' the dangers are irresponsible and bully them into not talking about numbers.
3. You can talk crap about made up numbers hoping to blind people with pseudoscience.
4. You can start testing well people (who, of course, will also likely have shreds of coronavirus [RNA] in them) and thus inflate your 'case figures' with 'asymptomatic carriers' (you will of course have to spin that to sound deadly even though any virologist knows the more symptom-less cases you have the less deadly is your pathogen).

The scientist said that if you take these simple steps 'you can have your own entirely manufactured pandemic up and running in weeks'. His analysis made so early in the hoax was brilliantly prophetic of what would actually unfold. Pulling all the information together in these recent chapters we have this is simple 1, 2, 3, of how you can delude virtually the entire human population into believing in a 'virus' that doesn't exist:

- A 'Covid case' is someone who tests positive with a test not testing for the 'virus'.
- A 'Covid death' is someone who dies of *any cause* within 28 days (or much longer) of testing positive with a test not testing for the 'virus'.
- Asymptomatic means there is nothing wrong with you, but they claim you can pass on what you don't have to justify locking

down (quarantining) healthy people in totality.

The foundations of the hoax are that simple. A study involving ten million people in Wuhan, published in November, 2020, demolished the whole lie about those without symptoms passing on the 'virus'. They found '300 asymptomatic cases' and traced their contacts to find that not one of them was detected with the 'virus'.

'Asymptomatic' patients and their contacts were isolated for no less than two weeks and nothing changed. I know it's all crap, but if you are going to claim that those without symptoms can transmit 'the virus' then you must produce evidence for that and they never have. Even World Health Organization official Dr Maria Van Kerkhove, head of the emerging diseases and zoonosis unit, said as early as June, 2020, that she doubted the validity of asymptomatic transmission. She said that 'from the data we have, it still seems to be rare that an asymptomatic person actually transmits onward to a secondary individual' and by 'rare' she meant that she couldn't cite any case of asymptomatic transmission.

### **The Ferguson factor**

The problem for the Cult as it headed into March, 2020, when the script had lockdown due to start, was that despite all the manipulation of the case and death figures they still did not have enough people alleged to have died from 'Covid' to justify mass house arrest. This was overcome in the way the scientist described: 'You can claim this is just the beginning and more deaths are imminent ... Use this as an excuse to quarantine everyone and then claim the quarantine prevented the expected millions of dead.' Enter one Professor Neil Ferguson, the Gates-funded 'epidemiologist' at the Gates-funded Imperial College in London. Ferguson is Britain's Christian Drosten in that he has a dire record of predicting health outcomes, but is still called upon to advise government on the next health outcome when another 'crisis' comes along. This may seem to be a strange and ridiculous thing to do. Why would you keep turning for policy guidance to people who have a history of being

monumentally wrong? Ah, but it makes sense from the Cult point of view. These 'experts' keep on producing predictions that suit the Cult agenda for societal transformation and so it was with Neil Ferguson as he revealed his horrific (and clearly insane) computer model predictions that allowed lockdowns to be imposed in Britain, the United States and many other countries. Ferguson does not have even an A-level in biology and would appear to have no formal training in computer modelling, medicine or epidemiology, according to Derek Winton, an MSc in Computational Intelligence. He wrote an article somewhat aghast at what Ferguson did which included taking no account of respiratory disease 'seasonality' which means it is far worse in the winter months. Who would have thought that respiratory disease could be worse in the winter? Well, certainly not Ferguson.

The massively China-connected Imperial College and its bizarre professor provided the excuse for the long-incubated Chinese model of human control to travel westward at lightning speed. Imperial College confirms on its website that it collaborates with the Chinese Research Institute; publishes more than 600 research papers every year with Chinese research institutions; has 225 Chinese staff; 2,600 Chinese students – the biggest international group; 7,000 former students living in China which is the largest group outside the UK; and was selected for a tour by China's President Xi Jinping during his state visit to the UK in 2015. The college takes major donations from China and describes itself as the UK's number one university collaborator with Chinese research institutions. The China communist/fascist government did not appear phased by the woeful predictions of Ferguson and Imperial when during the lockdown that Ferguson induced the college signed a five-year collaboration deal with China tech giant Huawei that will have Huawei's indoor 5G network equipment installed at the college's West London tech campus along with an 'AI cloud platform'. The deal includes Chinese sponsorship of Imperial's Venture Catalyst entrepreneurship competition. Imperial is an example of the enormous influence the Chinese government has within British and North American

universities and research centres – and further afield. Up to 200 academics from more than a dozen UK universities are being investigated on suspicion of ‘unintentionally’ helping the Chinese government build weapons of mass destruction by ‘transferring world-leading research in advanced military technology such as aircraft, missile designs and cyberweapons’. Similar scandals have broken in the United States, but it’s all a coincidence. Imperial College serves the agenda in many other ways including the promotion of every aspect of the United Nations Agenda 21/2030 (the Great Reset) and produced computer models to show that human-caused ‘climate change’ is happening when in the real world it isn’t. Imperial College is driving the climate agenda as it drives the ‘Covid’ agenda (both Cult hoaxes) while Patrick Vallance, the UK government’s Chief Scientific Adviser on ‘Covid’, was named Chief Scientific Adviser to the UN ‘climate change’ conference known as COP26 hosted by the government in Glasgow, Scotland. ‘Covid’ and ‘climate’ are fundamentally connected.

## **Professor Woeful**

From Imperial’s bosom came Neil Ferguson still advising government despite his previous disasters and it was announced early on that he and other key people like UK Chief Medical Adviser Chris Whitty had caught the ‘virus’ as the propaganda story was being sold. Somehow they managed to survive and we had Prime Minister Boris Johnson admitted to hospital with what was said to be a severe version of the ‘virus’ in this same period. His whole policy and demeanour changed when he returned to Downing Street. It’s a small world with these government advisors – especially in their communal connections to Gates – and Ferguson had partnered with Whitty to write a paper called ‘Infectious disease: Tough choices to reduce Ebola transmission’ which involved another scare-story that didn’t happen. Ferguson’s ‘models’ predicted that up to 150,000 could die from ‘mad cow disease’, or BSE, and its version in sheep if it was transmitted to humans. BSE was not transmitted and instead triggered by an organophosphate pesticide used to treat a pest on

cows. Fewer than 200 deaths followed from the human form. Models by Ferguson and his fellow incompetents led to the unnecessary culling of millions of pigs, cattle and sheep in the foot and mouth outbreak in 2001 which destroyed the lives and livelihoods of farmers and their families who had often spent decades building their herds and flocks. Vast numbers of these animals did not have foot and mouth and had no contact with the infection. Another 'expert' behind the cull was Professor Roy Anderson, a computer modeller at Imperial College specialising in the epidemiology of *human*, not animal, disease. Anderson has served on the Bill and Melinda Gates Grand Challenges in Global Health advisory board and chairs another Gates-funded organisation. Gates is everywhere.

In a precursor to the 'Covid' script Ferguson backed closing schools 'for prolonged periods' over the swine flu 'pandemic' in 2009 and said it would affect a third of the world population if it continued to spread at the speed he claimed to be happening. His mates at Imperial College said much the same and a news report said: 'One of the authors, the epidemiologist and disease modeller Neil Ferguson, who sits on the World Health Organisation's emergency committee for the outbreak, said the virus had "full pandemic potential".' Professor Liam Donaldson, the Chris Whitty of his day as Chief Medical Officer, said the worst case could see 30 percent of the British people infected by swine flu with 65,000 dying. Ferguson and Donaldson were indeed proved correct when at the end of the year the number of deaths attributed to swine flu was 392. The term 'expert' is rather liberally applied unfortunately, not least to complete idiots. Swine flu 'projections' were great for GlaxoSmithKline (GSK) as millions rolled in for its Pandemrix influenza vaccine which led to brain damage with children most affected. The British government (taxpayers) paid out more than £60 million in compensation after GSK was given immunity from prosecution. Yet another 'Covid' déjà vu. Swine flu was supposed to have broken out in Mexico, but Dr Wolfgang Wodarg, a German doctor, former member of parliament and critic of the 'Covid' hoax, observed 'the spread of swine flu' in Mexico City at the time. He

said: 'What we experienced in Mexico City was a very mild flu which did not kill more than usual – which killed even fewer people than usual.' Hying the fear against all the facts is not unique to 'Covid' and has happened many times before. Ferguson is reported to have over-estimated the projected death toll of bird flu (H5N1) by some three million-fold, but bird flu vaccine makers again made a killing from the scare. This is some of the background to the Neil Ferguson who produced the perfectly-timed computer models in early 2020 predicting that half a million people would die in Britain without draconian lockdown and 2.2 million in the United States. Politicians panicked, people panicked, and lockdowns of alleged short duration were instigated to 'flatten the curve' of cases gleaned from a test not testing for the 'virus'. I said at the time that the public could forget the 'short duration' bit. This was an agenda to destroy the livelihoods of the population and force them into mass control through dependency and there was going to be nothing 'short' about it. American researcher Daniel Horowitz described the consequences of the 'models' spewed out by Gates-funded Ferguson and Imperial College:

What led our government and the governments of many other countries into panic was a single Imperial College of UK study, funded by global warming activists, that predicted 2.2 million deaths if we didn't lock down the country. In addition, the reported 8-9% death rate in Italy scared us into thinking there was some other mutation of this virus that they got, which might have come here.

Together with the fact that we were finally testing and had the ability to actually report new cases, we thought we were headed for a death spiral. But again ... we can't flatten a curve if we don't know when the curve started.

How about it *never* started?

## **Giving them what they want**

An investigation by German news outlet *Welt Am Sonntag* (*World on Sunday*) revealed how in March, 2020, the German government gathered together 'leading scientists from several research institutes and universities' and 'together, they were to produce a [modelling]

paper that would serve as legitimization for further tough political measures'. The Cult agenda was justified by computer modelling not based on evidence or reality; it was specifically constructed to justify the Cult demand for lockdowns all over the world to destroy the independent livelihoods of the global population. All these modellers and everyone responsible for the 'Covid' hoax have a date with a trial like those in Nuremberg after World War Two when Nazis faced the consequences of their war crimes. These corrupt-beyond-belief 'modellers' wrote the paper according to government instructions and it said that that if lockdown measures were lifted then up to one million Germans would die from 'Covid-19' adding that some would die 'agonizingly at home, gasping for breath' unable to be treated by hospitals that couldn't cope. All lies. No matter – it gave the Cult all that it wanted. What did long-time government 'modeller' Neil Ferguson say? If the UK and the United States didn't lockdown half a million would die in Britain and 2.2 million Americans. Anyone see a theme here? 'Modellers' are such a crucial part of the lockdown strategy that we should look into their background and follow the money. Researcher Rosemary Frei produced an excellent article headlined 'The Modelling-paper Mafiosi'. She highlights a guy called John Edmunds, a British epidemiologist, and professor in the Faculty of Epidemiology and Population Health at the London School of Hygiene & Tropical Medicine. He studied at Imperial College. Edmunds is a member of government 'Covid' advisory bodies which have been dictating policy, the New and Emerging Respiratory Virus Threats Advisory Group (NERVTAG) and the Scientific Advisory Group for Emergencies (SAGE).

Ferguson, another member of NERVTAG and SAGE, led the way with the original 'virus' and Edmunds has followed in the 'variant' stage and especially the so-called UK or Kent variant known as the 'Variant of Concern' (VOC) B.1.1.7. He said in a co-written report for the Centre for Mathematical modelling of Infectious Diseases at the London School of Hygiene and Tropical Medicine, with input from the Centre's 'Covid-19' Working Group, that there was 'a realistic



possibility that VOC B.1.1.7 is associated with an increased risk of death compared to non-VOC viruses'. Fear, fear, fear, get the vaccine, fear, fear, fear, get the vaccine. Rosemary Frei reveals that almost all the paper's authors and members of the modelling centre's 'Covid-19' Working Group receive funding from the Bill and Melinda Gates Foundation and/or the associated Gates-funded Wellcome Trust. The paper was published by e-journal *Medrx* *xiv* which only publishes papers not peer-reviewed and the journal was established by an organisation headed by Facebook's Mark Zuckerberg and his missus. What a small world it is. Frei discovered that Edmunds is on the Scientific Advisory Board of the Coalition for Epidemic Preparedness Innovations (CEPI) which was established by the Bill and Melinda Gates Foundation, Klaus Schwab's Davos World Economic Forum and Big Pharma giant Wellcome. CEPI was 'launched in Davos [in 2017] to develop vaccines to stop future epidemics', according to its website. 'Our mission is to accelerate the development of vaccines against emerging infectious diseases and enable equitable access to these vaccines for people during outbreaks.' What kind people they are. Rosemary Frei reveals that Public Health England (PHE) director Susan Hopkins is an author of her organisation's non-peer-reviewed reports on 'new variants'. Hopkins is a professor of infectious diseases at London's Imperial College which is gifted tens of millions of dollars a year by the Bill and Melinda Gates Foundation. Gates-funded modelling disaster Neil Ferguson also co-authors Public Health England reports and he spoke in December, 2020, about the potential danger of the B.1.1.7. 'UK variant' promoted by Gates-funded modeller John Edmunds. When I come to the 'Covid vaccines' the 'new variants' will be shown for what they are – bollocks.

## **Connections, connections**

All these people and modellers are lockdown-obsessed or, put another way, they demand what the Cult demands. Edmunds said in January, 2021, that to ease lockdowns too soon would be a disaster and they had to 'vaccinate much, much, much more widely than the

elderly'. Rosemary Frei highlights that Edmunds is married to Jeanne Pimenta who is described in a LinkedIn profile as director of epidemiology at GlaxoSmithKline (GSK) and she held shares in the company. Patrick Vallance, co-chair of SAGE and the government's Chief Scientific Adviser, is a former executive of GSK and has a deferred bonus of shares in the company worth £600,000. GSK has serious business connections with Bill Gates and is collaborating with mRNA-'vaccine' company CureVac to make 'vaccines' for the new variants that Edmunds is talking about. GSK is planning a 'Covid vaccine' with drug giant Sanofi. Puppets Prime Minister Boris Johnson announced in the spring of 2021 that up to 60 million vaccine doses were to be made at the GSK facility at Barnard Castle in the English North East. Barnard Castle, with a population of just 6,000, was famously visited in breach of lockdown rules in April, 2020, by Johnson aide Dominic Cummings who said that he drove there 'to test his eyesight' before driving back to London. Cummings would be better advised to test his integrity – not that it would take long. The GSK facility had nothing to do with his visit then although I'm sure Patrick Vallance would have been happy to arrange an introduction and some tea and biscuits. Ruthless psychopath Gates has made yet another fortune from vaccines in collaboration with Big Pharma companies and gushes at the phenomenal profits to be made from vaccines – more than a 20-to-1 return as he told one interviewer. Gates also tweeted in December, 2019, with the foreknowledge of what was coming: 'What's next for our foundation? I'm particularly excited about what the next year could mean for one of the best buys in global health: vaccines.'

Modeller John Edmunds is a big promoter of vaccines as all these people appear to be. He's the dean of the London School of Hygiene & Tropical Medicine's Faculty of Epidemiology and Population Health which is primarily funded by the Bill and Melinda Gates Foundation and the Gates-established and funded GAVI vaccine alliance which is the Gates vehicle to vaccinate the world. The organisation Doctors Without Borders has described GAVI as being 'aimed more at supporting drug-industry desires to promote new

products than at finding the most efficient and sustainable means for fighting the diseases of poverty'. But then that's why the psychopath Gates created it. John Edmunds said in a video that the London School of Hygiene & Tropical Medicine is involved in every aspect of vaccine development including large-scale clinical trials. He contends that mathematical modelling can show that vaccines protect individuals and society. That's on the basis of shit in and shit out, I take it. Edmunds serves on the UK Vaccine Network as does Ferguson and the government's foremost 'Covid' adviser, the grim-faced, dark-eyed Chris Whitty. The Vaccine Network says it works 'to support the government to identify and shortlist targeted investment opportunities for the most promising vaccines and vaccine technologies that will help combat infectious diseases with epidemic potential, and to address structural issues related to the UK's broader vaccine infrastructure'. Ferguson is acting Director of the Imperial College Vaccine Impact Modelling Consortium which has funding from the Bill and Melina Gates Foundation and the Gates-created GAVI 'vaccine alliance'. Anyone wonder why these characters see vaccines as the answer to every problem? Ferguson is wildly enthusiastic in his support for GAVI's campaign to vaccinate children en masse in poor countries. You would expect someone like Gates who has constantly talked about the need to reduce the population to want to fund vaccines to keep more people alive. I'm sure that's why he does it. The John Edmunds London School of Hygiene & Tropical Medicine (LSHTM) has a Vaccines Manufacturing Innovation Centre which develops, tests and commercialises vaccines. Rosemary Frei writes:

The vaccines centre also performs affiliated activities like combating 'vaccine hesitancy'. The latter includes the Vaccine Confidence Project. The project's stated purpose is, among other things, 'to provide analysis and guidance for early response and engagement with the public to ensure sustained confidence in vaccines and immunisation'. The Vaccine Confidence Project's director is LSHTM professor Heidi Larson. For more than a decade she's been researching how to combat vaccine hesitancy.

How the bloody hell can blokes like John Edmunds and Neil Ferguson with those connections and financial ties model 'virus' case

and death projections for the government and especially in a way that gives their paymasters like Gates exactly what they want? It's insane, but this is what you find throughout the world.

### **'Covid' is not dangerous, oops, wait, yes it is**

Only days before Ferguson's nightmare scenario made Jackboot Johnson take Britain into a China-style lockdown to save us from a deadly 'virus' the UK government website gov.uk was reporting something very different to Ferguson on a page of official government guidance for 'high consequence infectious diseases (HCID)'. It said this about 'Covid-19':

*As of 19 March 2020, COVID-19 is no longer considered to be a high consequence infectious diseases (HCID) in the UK [my emphasis].* The 4 nations public health HCID group made an interim recommendation in January 2020 to classify COVID-19 as an HCID. This was based on consideration of the UK HCID criteria about the virus and the disease with information available during the early stages of the outbreak.

Now that more is known about COVID-19, the public health bodies in the UK have reviewed the most up to date information about COVID-19 against the UK HCID criteria. They have determined that several features have now changed; in particular, more information is available about mortality rates (low overall), and there is now greater clinical awareness and a specific and sensitive laboratory test, the availability of which continues to increase. The Advisory Committee on Dangerous Pathogens (ACDP) is also of the opinion that COVID-19 should no longer be classified as an HCID.

Soon after the government had been exposed for downgrading the risk they upgraded it again and everyone was back to singing from the same Cult hymn book. Ferguson and his fellow Gates clones indicated that lockdowns and restrictions would have to continue until a Gates-funded vaccine was developed. Gates said the same because Ferguson and his like were repeating the Gates script which is the Cult script. 'Flatten the curve' became an ongoing nightmare of continuing lockdowns with periods in between of severe restrictions in pursuit of destroying independent incomes and had nothing to do with protecting health about which the Cult gives not a shit. Why wouldn't Ferguson be pushing a vaccine 'solution' when he's owned by vaccine-obsessive Gates who makes a fortune from them and

when Ferguson heads the Vaccine Impact Modelling Consortium at Imperial College funded by the Gates Foundation and GAVI, the 'vaccine alliance', created by Gates as his personal vaccine promotion operation? To compound the human catastrophe that Ferguson's 'models' did so much to create he was later exposed for breaking his own lockdown rules by having sexual liaisons with his married girlfriend Antonia Staats at his home while she was living at another location with her husband and children. Staats was a 'climate' activist and senior campaigner at the Soros-funded Avaaz which I wouldn't trust to tell me that grass is green. Ferguson had to resign as a government advisor over this hypocrisy in May, 2020, but after a period of quiet he was back being quoted by the ridiculous media on the need for more lockdowns and a vaccine rollout. Other government-advising 'scientists' from Imperial College held the fort in his absence and said lockdown could be indefinite until a vaccine was found. The Cult script was being sung by the payrolled choir. I said there was no intention of going back to 'normal' when the 'vaccine' came because the 'vaccine' is part of a very different agenda that I will discuss in Human 2.0. Why would the Cult want to let the world go back to normal when destroying that normal forever was the whole point of what was happening? House arrest, closing businesses and schools through lockdown, (un)social distancing and masks all followed the Ferguson fantasy models. Again as I predicted (these people are so predictable) when the 'vaccine' arrived we were told that house arrest, lockdown, (un)social distancing and masks would still have to continue. I will deal with the masks in the next chapter because they are of fundamental importance.

## **Where's the 'pandemic'?**

Any mildly in-depth assessment of the figures revealed what was really going on. Cult-funded and controlled organisations still have genuine people working within them such is the number involved. So it is with Genevieve Briand, assistant program director of the Applied Economics master's degree program at Johns Hopkins

University. She analysed the impact that 'Covid-19' had on deaths from *all* causes in the United States using official data from the CDC for the period from early February to early September, 2020. She found that allegedly 'Covid' *related*-deaths exceeded those from heart disease which she found strange with heart disease always the biggest cause of fatalities. Her research became even more significant when she noted the sudden decline in 2020 of *all* non-'Covid' deaths: 'This trend is completely contrary to the pattern observed in all previous years ... the total decrease in deaths by other causes almost exactly equals the increase in deaths by Covid-19.' This was such a game, set and match in terms of what was happening that Johns Hopkins University deleted the article on the grounds that it 'was being used to support false and dangerous inaccuracies about the impact of the pandemic'. No – because it exposed the scam from official CDC figures and this was confirmed when those figures were published in January, 2021. Here we can see the effect of people dying from heart attacks, cancer, road accidents and gunshot wounds – *anything* – having 'Covid-19' on the death certificate along with those diagnosed from 'symptoms' who had even not tested positive with a test not testing for the 'virus'. I am not kidding with the gunshot wounds, by the way. Brenda Bock, coroner in Grand County, Colorado, revealed that two gunshot victims tested positive for the 'virus' within the previous 30 days and were therefore classified as 'Covid deaths'. Bock said: 'These two people had tested positive for Covid, but that's not what killed them. A gunshot wound is what killed them.' She said she had not even finished her investigation when the state listed the gunshot victims as deaths due to the 'virus'. The death and case figures for 'Covid-19' are an absolute joke and yet they are repeated like parrots by the media, politicians and alleged medical 'experts'. The official Cult narrative is the only show in town.

Genevieve Briand found that deaths from all causes were not exceptional in 2020 compared with previous years and a Spanish magazine published figures that said the same about Spain which was a 'Covid' propaganda hotspot at one point. *Discovery Salud*, a

health and medicine magazine, quoted government figures which showed how 17,000 *fewer* people died in Spain in 2020 than in 2019 and more than 26,000 fewer than in 2018. The age-standardised mortality rate for England and Wales when age distribution is taken into account was significantly lower in 2020 than the 1970s, 80s and 90s, and was only the ninth highest since 2000. Where is the 'pandemic'?

Post mortems and autopsies virtually disappeared for 'Covid' deaths amid claims that 'virus-infected' bodily fluids posed a risk to those carrying out the autopsy. This was rejected by renowned German pathologist and forensic doctor Klaus Püschel who said that he and his staff had by then done 150 autopsies on 'Covid' patients with no problems at all. He said they were needed to know why some 'Covid' patients suffered blood clots and not severe respiratory infections. The 'virus' is, after all, called SARS or 'severe acute respiratory syndrome'. I highlighted in the spring of 2020 this phenomenon and quoted New York intensive care doctor Cameron Kyle-Sidell who posted a soon deleted YouTube video to say that they had been told to prepare to treat an infectious disease called 'Covid-19', but that was not what they were dealing with. Instead he likened the lung condition of the most severely ill patients to what you would expect with cabin depressurisation in a plane at 30,000 feet or someone dropped on the top of Everest without oxygen or acclimatisation. I have never said this is not happening to a small minority of alleged 'Covid' patients – I am saying this is not caused by a phantom 'contagious virus'. Indeed Kyle-Sidell said that 'Covid-19' was not the disease they were told was coming their way. 'We are operating under a medical paradigm that is untrue,' he said, and he believed they were treating the wrong disease: 'These people are being slowly starved of oxygen.' Patients would take off their oxygen masks in a state of fear and stress and while they were blue in the face on the brink of death. They did not look like patients dying of pneumonia. You can see why they don't want autopsies when their virus doesn't exist and there is another condition in some people that they don't wish to be uncovered. I should add here that

the 5G system of millimetre waves was being rapidly introduced around the world in 2020 and even more so now as they fire 5G at the Earth from satellites. At 60 gigahertz within the 5G range that frequency interacts with the oxygen molecule and stops people breathing in sufficient oxygen to be absorbed into the bloodstream. They are installing 5G in schools and hospitals. The world is not mad or anything. 5G can cause major changes to the lungs and blood as I detail in *The Answer* and these consequences are labelled 'Covid-19', the alleged symptoms of which can be caused by 5G and other electromagnetic frequencies as cells respond to radiation poisoning.

### **The 'Covid death' scam**

Dr Scott Jensen, a Minnesota state senator and medical doctor, exposed 'Covid' Medicare payment incentives to hospitals and death certificate manipulation. He said he was sent a seven-page document by the US Department of Health 'coaching' him on how to fill out death certificates which had never happened before. The document said that he didn't need to have a laboratory test for 'Covid-19' to put that on the death certificate and that shocked him when death certificates are supposed to be about facts. Jensen described how doctors had been 'encouraged, if not pressured' to make a diagnosis of 'Covid-19' if they thought it was probable or '*presumed*'. No positive test was necessary – not that this would have mattered anyway. He said doctors were told to diagnose 'Covid' by symptoms when these were the same as colds, allergies, other respiratory problems, and certainly with influenza which 'disappeared' in the 'Covid' era. A common sniffle was enough to get the dreaded verdict. Ontario authorities decreed that a single care home resident with *one* symptom from a long list must lead to the isolation of the entire home. Other courageous doctors like Jensen made the same point about death figure manipulation and how deaths by other causes were falling while 'Covid-19 deaths' were rising at the same rate due to re-diagnosis. Their videos rarely survive long on YouTube with its Cult-supporting algorithms courtesy of CEO Susan Wojcicki and her bosses at Google. Figure-tampering was so glaring



and ubiquitous that even officials were letting it slip or outright saying it. UK chief scientific adviser Patrick Vallance said on one occasion that 'Covid' on the death certificate doesn't mean 'Covid' was the cause of death (so why the hell is it there?) and we had the rare sight of a BBC reporter telling the truth when she said: 'Someone could be successfully treated for Covid, in say April, discharged, and then in June, get run over by a bus and die ... That person would still be counted as a Covid death in England.' Yet the BBC and the rest of the world media went on repeating the case and death figures as if they were real. Illinois Public Health Director Dr Ngozi Ezike revealed the deceit while her bosses must have been clenching their buttocks:

If you were in a hospice and given a few weeks to live and you were then found to have Covid that would be counted as a Covid death. [There might be] a clear alternate cause, but it is still listed as a Covid death. So everyone listed as a Covid death doesn't mean that was the cause of the death, but that they had Covid at the time of death.

Yes, a 'Covid virus' never shown to exist and tested for with a test not testing for the 'virus'. In the first period of the pandemic hoax through the spring of 2020 the process began of designating almost everything a 'Covid' death and this has continued ever since. I sat in a restaurant one night listening to a loud conversation on the next table where a family was discussing in bewilderment how a relative who had no symptoms of 'Covid', and had died of a long-term problem, could have been diagnosed a death by the 'virus'. I could understand their bewilderment. If they read this book they will know why this medical fraud has been perpetrated the world over.

### **Some media truth shock**

The media ignored the evidence of death certificate fraud until eventually one columnist did speak out when she saw it first-hand. Bel Mooney is a long-time national newspaper journalist in Britain currently working for the *Daily Mail*. Her article on February 19th, 2021, carried this headline: 'My dad Ted passed three Covid tests

and died of a chronic illness yet he's officially one of Britain's 120,000 victims of the virus and is far from alone ... so how many more are there?' She told how her 99-year-old father was in a care home with a long-standing chronic obstructive pulmonary disease and vascular dementia. Maybe, but he was still aware enough to tell her from the start that there was no 'virus' and he refused the 'vaccine' for that reason. His death was not unexpected given his chronic health problems and Mooney said she was shocked to find that 'Covid-19' was declared the cause of death on his death certificate. She said this was a 'bizarre and unacceptable untruth' for a man with long-time health problems who had tested negative twice at the home for the 'virus'. I was also shocked by this story although not by what she said. I had been highlighting the death certificate manipulation for ten months. It was the confirmation that a professional full-time journalist only realised this was going on when it affected her directly and neither did she know that whether her dad tested positive or negative was irrelevant with the test not testing for the 'virus'. Where had she been? She said she did not believe in 'conspiracy theories' without knowing I'm sure that this and 'conspiracy theorists' were terms put into widespread circulation by the CIA in the 1960s to discredit those who did not accept the ridiculous official story of the Kennedy assassination. A blanket statement of 'I don't believe in conspiracy theories' is always bizarre. The dictionary definition of the term alone means the world is drowning in conspiracies. What she said was even more daft when her dad had just been affected by the 'Covid' conspiracy. Why else does she think that 'Covid-19' was going on the death certificates of people who died of something else?

To be fair once she saw from personal experience what was happening she didn't mince words. Mooney was called by the care home on the morning of February 9th to be told her father had died in his sleep. When she asked for the official cause of death what came back was 'Covid-19'. Mooney challenged this and was told there had been deaths from Covid on the dementia floor (confirmed by a test not testing for the 'virus') so they considered it 'reasonable

to assume'. 'But doctor,' Mooney rightly protested, 'an assumption isn't a diagnosis.' She said she didn't blame the perfectly decent and sympathetic doctor – 'he was just doing his job'. Sorry, but that's *bullshit*. He wasn't doing his job at all. He was putting a false cause of death on the death certificate and that is a criminal offence for which he should be brought to account and the same with the millions of doctors worldwide who have done the same. They were not doing their job they were following orders and that must not wash at new Nuremberg trials any more than it did at the first ones. Mooney's doctor was 'assuming' (presuming) as he was told to, but 'just following orders' makes no difference to his actions. A doctor's job is to serve the patient and the truth, not follow orders, but that's what they have done all over the world and played a central part in making the 'Covid' hoax possible with all its catastrophic consequences for humanity. Shame on them and they must answer for their actions. Mooney said her disquiet worsened when she registered her father's death by telephone and was told by the registrar there had been very many other cases like hers where 'the deceased' had not tested positive for 'Covid' yet it was recorded as the cause of death. The test may not matter, but those involved at their level *think* it matters and it shows a callous disregard for accurate diagnosis. The pressure to do this is coming from the top of the national 'health' pyramids which in turn obey the World Health Organization which obeys Gates and the Cult. Mooney said the registrar agreed that this must distort the national figures adding that 'the strangest thing is that every winter we record countless deaths from flu, and this winter there have been none. Not one!' She asked if the registrar thought deaths from flu were being misdiagnosed and lumped together with 'Covid' deaths. The answer was a 'puzzled yes'. Mooney said that the funeral director said the same about 'Covid' deaths which had nothing to do with 'Covid'. They had lost count of the number of families upset by this and other funeral companies in different countries have had the same experience. Mooney wrote:

The nightly shroud-waving and shocking close-ups of pain imposed on us by the TV news bewildered and terrified the population into eager compliance with lockdowns. We were invited to 'save the NHS' and to grieve for strangers – the real-life loved ones behind those shocking death counts. Why would the public imagine what I now fear, namely that the way Covid-19 death statistics are compiled might make the numbers seem greater than they are?

Oh, just a little bit – like 100 percent.

## **Do the maths**

Mooney asked why a country would wish to skew its mortality figures by wrongly certifying deaths? What had been going on? Well, if you don't believe in conspiracies you will never find the answer which is that *it's a conspiracy*. She did, however, describe what she had discovered as a 'national scandal'. In reality it's a global scandal and happening everywhere. Pillars of this conspiracy were all put into place before the button was pressed with the Drosten PCR protocol and high amplifications to produce the cases and death certificate changes to secure illusory 'Covid' deaths. Mooney notes that normally two doctors were needed to certify a death, with one having to know the patient, and how the rules were changed in the spring of 2020 to allow one doctor to do this. In the same period 'Covid deaths' were decreed to be all cases where Covid-19 was put on the death certificate even without a positive test or any symptoms. Mooney asked: 'How many of the 30,851 (as of January 15) care home resident deaths with Covid-19 on the certificate (32.4 per cent of all deaths so far) were based on an assumption, like that of my father? And what has that done to our national psyche?' All of them is the answer to the first question and it has devastated and dismantled the national psyche, actually the global psyche, on a colossal scale. In the UK case and death data is compiled by organisations like Public Health England (PHE) and the Office for National Statistics (ONS). Mooney highlights the insane policy of counting a death from any cause as 'Covid-19' if this happens within 28 days of a positive test (with a test not testing for the 'virus') and she points out that ONS statistics reflect deaths 'involving Covid' 'or due to Covid' which meant in practice any

death where 'Covid-19' was mentioned on the death certificate. She described the consequences of this fraud:

Most people will accept the narrative they are fed, so panicky governments here and in Europe witnessed the harsh measures enacted in totalitarian China and jumped into lockdown. Headlines about Covid deaths tolled like the knell that would bring doomsday to us all. Fear stalked our empty streets. Politicians parroted the frankly ridiculous aim of 'zero Covid' and shut down the economy, while most British people agreed that lockdown was essential and (astonishingly to me, as a patriotic Brit) even wanted more restrictions.

For what? Lies on death certificates? Never mind the grim toll of lives ruined, suicides, schools closed, rising inequality, depression, cancelled hospital treatments, cancer patients in a torture of waiting, poverty, economic devastation, loneliness, families kept apart, and so on. How many lives have been lost as a direct result of lockdown?

She said that we could join in a national chorus of shock and horror at reaching the 120,000 death toll which was surely certain to have been totally skewed all along, but what about the human cost of lockdown justified by these 'death figures'? *The British Medical Journal* had reported a 1,493 percent increase in cases of children taken to Great Ormond Street Hospital with abusive head injuries alone and then there was the effect on families:

Perhaps the most shocking thing about all this is that families have been kept apart – and obeyed the most irrational, changing rules at the whim of government – because they believed in the statistics. They succumbed to fear, which his generation rejected in that war fought for freedom. Dad (God rest his soul) would be angry. And so am I.

Another theme to watch is that in the winter months when there are more deaths from all causes they focus on 'Covid' deaths and in the summer when the British Lung Foundation says respiratory disease plummets by 80 percent they rage on about 'cases'. Either way fascism on population is always the answer.

## **Nazi eugenics in the 21st century**

Elderly people in care homes have been isolated from their families month after lonely month with no contact with relatives and grandchildren who were banned from seeing them. We were told

that lockdown fascism was to 'protect the vulnerable' like elderly people. At the same time Do Not Resuscitate (DNR) orders were placed on their medical files so that if they needed resuscitation it wasn't done and 'Covid-19' went on their death certificates. Old people were not being 'protected' they were being culled – murdered in truth. DNR orders were being decreed for disabled and young people with learning difficulties or psychological problems. The UK Care Quality Commission, a non-departmental body of the Department of Health and Social Care, found that 34 percent of those working in health and social care were pressured into placing 'do not attempt cardiopulmonary resuscitation' orders on 'Covid' patients who suffered from disabilities and learning difficulties without involving the patient or their families in the decision. UK judges ruled that an elderly woman with dementia should have the DNA-manipulating 'Covid vaccine' against her son's wishes and that a man with severe learning difficulties should have the job despite his family's objections. Never mind that many had already died. The judiciary always supports doctors and government in fascist dictatorships. They wouldn't dare do otherwise. A horrific video was posted showing fascist officers from Los Angeles police forcibly giving the 'Covid' shot to women with special needs who were screaming that they didn't want it. The same fascists are seen giving the jab to a sleeping elderly woman in a care home. This is straight out of the Nazi playbook. Hitler's Nazis committed mass murder of the mentally ill and physically disabled throughout Germany and occupied territories in the programme that became known as Aktion T4, or just T4. Sabbatian-controlled Hitler and his grotesque crazies set out to kill those they considered useless and unnecessary. The Reich Committee for the Scientific Registering of Hereditary and Congenital Illnesses registered the births of babies identified by physicians to have 'defects'. By 1941 alone more than 5,000 children were murdered by the state and it is estimated that in total the number of innocent people killed in Aktion T4 was between 275,000 and 300,000. Parents were told their children had been sent away for 'special treatment' never to return. It is rather pathetic to see claims about plans for new extermination camps being dismissed today

when the same force behind current events did precisely that 80 years ago. Margaret Sanger was a Cult operative who used 'birth control' to sanitise her programme of eugenics. Organisations she founded became what is now Planned Parenthood. Sanger proposed that 'the whole dysgenic population would have its choice of segregation or sterilization'. These included epileptics, 'feeble-minded', and prostitutes. Sanger opposed charity because it perpetuated 'human waste'. She reveals the Cult mentality and if anyone thinks that extermination camps are a 'conspiracy theory' their naivety is touching if breathtakingly stupid.

If you don't believe that doctors can act with callous disregard for their patients it is worth considering that doctors and medical staff agreed to put government-decreed DNR orders on medical files and do nothing when resuscitation is called for. I don't know what you call such people in your house. In mine they are Nazis from the Josef Mengele School of Medicine. Phenomenal numbers of old people have died worldwide from the effects of lockdown, depression, lack of treatment, the 'vaccine' (more later) and losing the will to live. A common response at the start of the manufactured pandemic was to remove old people from hospital beds and transfer them to nursing homes. The decision would result in a mass cull of elderly people in those homes through lack of treatment – *not* 'Covid'. Care home whistleblowers have told how once the 'Covid' era began doctors would not come to their homes to treat patients and they were begging for drugs like antibiotics that often never came. The most infamous example was ordered by New York governor Andrew Cuomo, brother of a moronic CNN host, who amazingly was given an Emmy Award for his handling of the 'Covid crisis' by the ridiculous Wokers that hand them out. Just how ridiculous could be seen in February, 2021, when a Department of Justice and FBI investigation began into how thousands of old people in New York died in nursing homes after being discharged from hospital to make way for 'Covid' patients on Cuomo's say-so – and how he and his staff covered up these facts. This couldn't have happened to a nicer psychopath. Even then there was a 'Covid' spin. Reports said that

thousands of old people who tested positive for 'Covid' in hospital were transferred to nursing homes to both die of 'Covid' and transmit it to others. No – they were in hospital because they were ill and the fact that they tested positive with a test not testing for the 'virus' is irrelevant. They were ill often with respiratory diseases ubiquitous in old people near the end of their lives. Their transfer out of hospital meant that their treatment stopped and many would go on to die.

### **They're old. Who gives a damn?**

I have exposed in the books for decades the Cult plan to cull the world's old people and even to introduce at some point what they call a 'demise pill' which at a certain age everyone would take and be out of here by law. In March, 2021, Spain legalised euthanasia and assisted suicide following the Netherlands, Belgium, Luxembourg and Canada on the Tiptoe to the demise pill. Treatment of old people by many 'care' homes has been a disgrace in the 'Covid' era. There are many, many, caring staff – I know some. There have, however, been legions of stories about callous treatment of old people and their families. Police were called when families came to take their loved ones home in the light of isolation that was killing them. They became prisoners of the state. Care home residents in insane, fascist Ontario, Canada, were not allowed to leave their *room* once the 'Covid' hoax began. UK staff have even wheeled elderly people away from windows where family members were talking with them. Oriana Criscuolo from Stockport in the English North West dropped off some things for her 80-year-old father who has Parkinson's disease and dementia and she wanted to wave to him through a ground-floor window. She was told that was 'illegal'. When she went anyway they closed the curtains in the middle of the day. Oriana said:

It's just unbelievable. I cannot understand how care home staff – people who are being paid to care – have become so uncaring. Their behaviour is inhumane and cruel. It's beyond belief.



She was right and this was not a one-off. What a way to end your life in such loveless circumstances. UK registered nurse Nicky Millen, a proper old school nurse for 40 years, said that when she started her career care was based on dignity, choice, compassion and empathy. Now she said 'the things that are important to me have gone out of the window.' She was appalled that people were dying without their loved ones and saying goodbye on iPads. Nicky described how a distressed 89-year-old lady stroked her face and asked her 'how many paracetamol would it take to finish me off'. Life was no longer worth living while not seeing her family. Nicky said she was humiliated in front of the ward staff and patients for letting the lady stroke her face and giving her a cuddle. Such is the dehumanisation that the 'Covid' hoax has brought to the surface. Nicky worked in care homes where patients told her they were being held prisoner. 'I want to live until I die', one said to her. 'I had a lady in tears because she hadn't seen her great-grandson.' Nicky was compassionate old school meeting psychopathic New Normal. She also said she had worked on a 'Covid' ward with no 'Covid' patients. Jewish writer Shai Held wrote an article in March, 2020, which was headlined 'The Staggering, Heartless Cruelty Toward the Elderly'. What he described was happening from the earliest days of lockdown. He said 'the elderly' were considered a group and not unique individuals (the way of the Woke). Shai Held said:

Notice how the all-too-familiar rhetoric of dehumanization works: 'The elderly' are bunched together as a faceless mass, all of them considered culprits and thus effectively deserving of the suffering the pandemic will inflict upon them. Lost entirely is the fact that the elderly are individual human beings, each with a distinctive face and voice, each with hopes and dreams, memories and regrets, friendships and marriages, loves lost and loves sustained.

'The elderly' have become another dehumanised group for which anything goes and for many that has resulted in cold disregard for their rights and their life. The distinctive face that Held talks about is designed to be deleted by masks until everyone is part of a faceless mass.

## **'War-zone' hospitals myth**

Again and again medical professionals have told me what was really going on and how hospitals 'overrun like war zones' according to the media were virtually empty. The mantra from medical whistleblowers was please don't use my name or my career is over. Citizen journalists around the world sneaked into hospitals to film evidence exposing the 'war-zone' lie. They really *were* largely empty with closed wards and operating theatres. I met a hospital worker in my town on the Isle of Wight during the first lockdown in 2020 who said the only island hospital had never been so quiet. Lockdown was justified by the psychopaths to stop hospitals being overrun. At the same time that the island hospital was near-empty the military arrived here to provide *extra beds*. It was all propaganda to ramp up the fear to ensure compliance with fascism as were never-used temporary hospitals with thousands of beds known as Nightingales and never-used make-shift mortuaries opened by the criminal UK government. A man who helped to install those extra island beds attributed to the army said they were never used and the hospital was empty. Doctors and nurses 'stood around talking or on their phones, wandering down to us to see what we were doing'. There were no masks or social distancing. He accused the useless local island paper, the *County Press*, of 'pumping the fear as if our hospital was overrun and we only have one so it should have been'. He described ambulances parked up with crews outside in deck chairs. When his brother called an ambulance he was told there was a two-hour backlog which he called 'bullshit'. An old lady on the island fell 'and was in a bad way', but a caller who rang for an ambulance was told the situation wasn't urgent enough. Ambulance stations were working under capacity while people would hear ambulances with sirens blaring driving through the streets. When those living near the stations realised what was going on they would follow them as they left, circulated around an urban area with the sirens going, and then came back without stopping. All this was to increase levels of fear and the same goes for the 'ventilator shortage crisis' that cost tens of millions for hastily produced ventilators never to be used.

Ambulance crews that agreed to be exploited in this way for fear propaganda might find themselves a mirror. I wish them well with that. Empty hospitals were the obvious consequence of treatment and diagnoses of non-'Covid' conditions cancelled and those involved handed a death sentence. People have been dying at home from undiagnosed and untreated cancer, heart disease and other life-threatening conditions to allow empty hospitals to deal with a 'pandemic' that wasn't happening.

## **Death of the innocent**

'War-zones' have been laying off nursing staff, even doctors where they can. There was no work for them. Lockdown was justified by saving lives and protecting the vulnerable they were actually killing with DNR orders and preventing empty hospitals being 'overrun'. In Britain the mantra of stay at home to 'save the NHS' was everywhere and across the world the same story was being sold when it was all lies. Two California doctors, Dan Erickson and Artin Massihi at Accelerated Urgent Care in Bakersfield, held a news conference in April, 2020, to say that intensive care units in California were 'empty, essentially', with hospitals shutting floors, not treating patients and laying off doctors. The California health system was working at minimum capacity 'getting rid of doctors because we just don't have the volume'. They said that people with conditions such as heart disease and cancer were not coming to hospital out of fear of 'Covid-19'. Their video was deleted by Susan Wojcicki's Cult-owned YouTube after reaching five million views. Florida governor Ron Desantis, who rejected the severe lockdowns of other states and is being targeted for doing so, said that in March, 2020, every US governor was given models claiming they would run out of hospital beds in days. That was never going to happen and the 'modellers' knew it. Deceit can be found at every level of the system. Urgent children's operations were cancelled including fracture repairs and biopsies to spot cancer. Eric Nicholls, a consultant paediatrician, said 'this is obviously concerning and we need to return to normal operating and to increase capacity as soon as possible'. Psychopaths

in power were rather less concerned *because* they are psychopaths. Deletion of urgent care and diagnosis has been happening all over the world and how many kids and others have died as a result of the actions of these cold and heartless lunatics dictating 'health' policy? The number must be stratospheric. Richard Sullivan, professor of cancer and global health at King's College London, said people feared 'Covid' more than cancer such was the campaign of fear. 'Years of lost life will be quite dramatic', Sullivan said, with 'a huge amount of avoidable mortality'. Sarah Woolnough, executive director for policy at Cancer Research UK, said there had been a 75 percent drop in urgent referrals to hospitals by family doctors of people with suspected cancer. Sullivan said that 'a lot of services have had to scale back – we've seen a dramatic decrease in the amount of elective cancer surgery'. Lockdown deaths worldwide has been absolutely fantastic with the *New York Post* reporting how data confirmed that 'lockdowns end more lives than they save':

There was a sharp decline in visits to emergency rooms and an increase in fatal heart attacks because patients didn't receive prompt treatment. Many fewer people were screened for cancer. Social isolation contributed to excess deaths from dementia and Alzheimer's.

Researchers predicted that the social and economic upheaval would lead to tens of thousands of "deaths of despair" from drug overdoses, alcoholism and suicide. As unemployment surged and mental-health and substance-abuse treatment programs were interrupted, the reported levels of anxiety, depression and suicidal thoughts increased dramatically, as did alcohol sales and fatal drug overdoses.

This has been happening while nurses and other staff had so much time on their hands in the 'war-zones' that Tic-Tok dancing videos began appearing across the Internet with medical staff dancing around in empty wards and corridors as people died at home from causes that would normally have been treated in hospital.

## **Mentions in dispatches**

One brave and truth-committed whistleblower was Louise Hampton, a call handler with the UK NHS who made a viral Internet video saying she had done 'fuck all' during the 'pandemic'

which was 'a load of bollocks'. She said that 'Covid-19' was rebranded flu and of course she lost her job. This is what happens in the medical and endless other professions now when you tell the truth. Louise filmed inside 'war-zone' accident and emergency departments to show they were empty and I mean *empty* as in no one there. The mainstream media could have done the same and blown the gaff on the whole conspiracy. They haven't to their eternal shame. Not that most 'journalists' seem capable of manifesting shame as with the psychopaths they slavishly repeat without question. The relative few who were admitted with serious health problems were left to die alone with no loved ones allowed to see them because of 'Covid' rules and they included kids dying without the comfort of mum and dad at their bedside while the evil behind this couldn't give a damn. It was all good fun to them. A Scottish NHS staff nurse publicly quit in the spring of 2021 saying: 'I can no longer be part of the lies and the corruption by the government.' She said hospitals 'aren't full, the beds aren't full, beds have been shut, wards have been shut'. Hospitals were never busy throughout 'Covid'. The staff nurse said that Nicola Sturgeon, tragically the leader of the Scottish government, was on television saying save the hospitals and the NHS – 'but the beds are empty' and 'we've not seen flu, we always see flu every year'. She wrote to government and spoke with her union Unison (the unions are Cult-compromised and *useless*, but nothing changed. Many of her colleagues were scared of losing their jobs if they spoke out as they wanted to. She said nursing staff were being affected by wearing masks all day and 'my head is splitting every shift from wearing a mask'. The NHS is part of the fascist tyranny and must be dismantled so we can start again with human beings in charge. (Ironically, hospitals were reported to be busier again when official 'Covid' cases *fell* in spring/summer of 2021 and many other conditions required treatment at the same time as *the fake vaccine rollout*.)

I will cover the 'Covid vaccine' scam in detail later, but it is another indicator of the sickening disregard for human life that I am highlighting here. The DNA-manipulating concoctions do not fulfil

the definition of a 'vaccine', have never been used on humans before and were given only emergency approval because trials were not completed and they continued using the unknowing public. The result was what a NHS senior nurse with responsibility for 'vaccine' procedure said was 'genocide'. She said the 'vaccines' were not 'vaccines'. They had not been shown to be safe and claims about their effectiveness by drug companies were 'poetic licence'. She described what was happening as a 'horrid act of human annihilation'. The nurse said that management had instigated a policy of not providing a Patient Information Leaflet (PIL) before people were 'vaccinated' even though health care professionals are supposed to do this according to protocol. Patients should also be told that they are taking part in an ongoing clinical trial. Her challenges to what is happening had seen her excluded from meetings and ridiculed in others. She said she was told to 'watch my step ... or I would find myself surplus to requirements'. The nurse, who spoke anonymously in fear of her career, said she asked her NHS manager why he/she was content with taking part in genocide against those having the 'vaccines'. The reply was that everyone had to play their part and to 'put up, shut up, and get it done'. Government was 'leaning heavily' on NHS management which was clearly leaning heavily on staff. This is how the global 'medical' hierarchy operates and it starts with the Cult and its World Health Organization.

She told the story of a doctor who had the Pfizer jab and when questioned had no idea what was in it. The doctor had never read the literature. We have to stop treating doctors as intellectual giants when so many are moral and medical pygmies. The doctor did not even know that the 'vaccines' were not fully approved or that their trials were ongoing. They were, however, asking their patients if they minded taking part in follow-ups for research purposes – yes, the *ongoing clinical trial*. The nurse said the doctor's ignorance was not rare and she had spoken to a hospital consultant who had the jab without any idea of the background or that the 'trials' had not been completed. Nurses and pharmacists had shown the same ignorance.

'My NHS colleagues have forsaken their duty of care, broken their code of conduct – Hippocratic Oath – and have been brainwashed just the same as the majority of the UK public through propaganda ...' She said she had not been able to recruit a single NHS colleague, doctor, nurse or pharmacist to stand with her and speak out. Her union had refused to help. She said that if the genocide came to light she would not hesitate to give evidence at a Nuremberg-type trial against those in power who could have affected the outcomes but didn't.

### **And all for what?**

To put the nonsense into perspective let's say the 'virus' does exist and let's go completely crazy and accept that the official manipulated figures for cases and deaths are accurate. *Even then* a study by Stanford University epidemiologist Dr John Ioannidis published on the World Health Organization website produced an average infection to fatality rate of ... *0.23 percent!* Ioannidis said: 'If one could sample equally from all locations globally, the median infection fatality rate might even be substantially lower than the 0.23% observed in my analysis.' For healthy people under 70 it was ... *0.05 percent!* This compares with the 3.4 percent claimed by the Cult-owned World Health Organization when the hoax was first played and maximum fear needed to be generated. An updated Stanford study in April, 2021, put the 'infection' to 'fatality' rate at just 0.15 percent. Another team of scientists led by Megan O'Driscoll and Henrik Salje studied data from 45 countries and published their findings on the Nature website. For children and young people the figure is so small it virtually does not register although authorities will be hyping dangers to the young when they introduce DNA-manipulating 'vaccines' for children. The O'Driscoll study produced an average infection-fatality figure of 0.003 for children from birth to four; 0.001 for 5 to 14; 0.003 for 15 to 19; and it was still only 0.456 up to 64. To claim that children must be 'vaccinated' to protect them from 'Covid' is an obvious lie and so there must be another reason and there is. What's more the average age of a 'Covid' death is akin

to the average age that people die in general. The average age of death in England is about 80 for men and 83 for women. The average age of death from alleged 'Covid' is between 82 and 83. California doctors, Dan Erickson and Artin Massihi, said at their April media conference that projection models of millions of deaths had been 'woefully inaccurate'. They produced detailed figures showing that Californians had a 0.03 chance of dying from 'Covid' based on the number of people who tested positive (with a test not testing for the 'virus'). Erickson said there was a 0.1 percent chance of dying from 'Covid' in the *state* of New York, not just the city, and a 0.05 percent chance in Spain, a centre of 'Covid-19' hysteria at one stage. The Stanford studies supported the doctors' data with fatality rate estimates of 0.23 and 0.15 percent. How close are these figures to my estimate of *zero*? Death-rate figures claimed by the World Health Organization at the start of the hoax were some 15 times higher. The California doctors said there was no justification for lockdowns and the economic devastation they caused. Everything they had ever learned about quarantine was that you quarantine the *sick* and not the healthy. They had never seen this before and it made no medical sense.

Why in the in the light of all this would governments and medical systems the world over say that billions must go under house arrest; lose their livelihood; in many cases lose their mind, their health and their life; force people to wear masks dangerous to health and psychology; make human interaction and even family interaction a criminal offence; ban travel; close restaurants, bars, watching live sport, concerts, theatre, and any activity involving human togetherness and discourse; and closing schools to isolate children from their friends and cause many to commit suicide in acts of hopelessness and despair? The California doctors said lockdown consequences included increased child abuse, partner abuse, alcoholism, depression, and other impacts they were seeing every day. Who would do that to the entire human race if not mentally-ill psychopaths of almost unimaginable extremes like Bill Gates? We must face the reality of what we are dealing with and come out of



denial. Fascism and tyranny are made possible only by the target population submitting and acquiescing to fascism and tyranny. The whole of human history shows that to be true. Most people naively and unquestioning believed what they were told about a 'deadly virus' and meekly and weakly submitted to house arrest. Those who didn't believe it – at least in total – still submitted in fear of the consequences of not doing so. For the rest who wouldn't submit draconian fines have been imposed, brutal policing by psychopaths *for* psychopaths, and condemnation from the meek and weak who condemn the Pushbackers on behalf of the very force that has them, too, in its gunights. 'Pathetic' does not even begin to suffice. Britain's brainless 'Health' Secretary Matt Hancock warned anyone lying to border officials about returning from a list of 'hotspot' countries could face a jail sentence of up to ten years which is more than for racially-aggravated assault, incest and attempting to have sex with a child under 13. Hancock is a lunatic, but he has the state apparatus behind him in a Cult-led chain reaction and the same with UK 'Vaccine Minister' Nadhim Zahawi, a prominent member of the mega-Cult secret society, Le Cercle, which featured in my earlier books. The Cult enforces its will on governments and medical systems; government and medical systems enforce their will on business and police; business enforces its will on staff who enforce it on customers; police enforce the will of the Cult on the population and play their essential part in creating a world of fascist control that their own children and grandchildren will have to live in their entire lives. It is a hierarchical pyramid of imposition and acquiescence and, yes indeed, of clinical insanity.

Does anyone bright enough to read this book have to ask what the answer is? I think not, but I will reveal it anyway in the fewest of syllables: Tell the psychos and their moronic lackeys to fuck off and let's get on with our lives. We are many – They are few.

## CHAPTER SEVEN

### **War on your mind**

*One believes things because one has been conditioned to believe them*

*Aldous Huxley, Brave New World*

I have described the 'Covid' hoax as a 'Psyop' and that is true in every sense and on every level in accordance with the definition of that term which is psychological warfare. Break down the 'Covid pandemic' to the foundation themes and it is psychological warfare on the human individual and collective mind.

The same can be said for the entire human belief system involving every subject you can imagine. Huxley was right in his contention that people believe what they are conditioned to believe and this comes from the repetition throughout their lives of the same falsehoods. They spew from government, corporations, media and endless streams of 'experts' telling you what the Cult wants you to believe and often believing it themselves (although *far* from always). 'Experts' are rewarded with 'prestigious' jobs and titles and as agents of perceptual programming with regular access to the media. The Cult has to control the narrative – control *information* – or they lose control of the vital, crucial, without-which-they-cannot-prevail public perception of reality. The foundation of that control today is the Internet made possible by the Defense Advanced Research Projects Agency (DARPA), the incredibly sinister technological arm of the Pentagon. The Internet is the result of military technology.

DARPA openly brags about establishing the Internet which has been a long-term project to lasso the minds of the global population. I have said for decades the plan is to control information to such an extreme that eventually no one would see or hear anything that the Cult does not approve. We are closing in on that end with ferocious censorship since the 'Covid' hoax began and in my case it started back in the 1990s in terms of books and speaking venues. I had to create my own publishing company in 1995 precisely because no one else would publish my books even then. I think they're all still running.

## **Cult Internet**

To secure total control of information they needed the Internet in which pre-programmed algorithms can seek out 'unclean' content for deletion and even stop it being posted in the first place. The Cult had to dismantle print and non-Internet broadcast media to ensure the transfer of information to the appropriate-named 'Web' – a critical expression of the *Cult* web. We've seen the ever-quickening demise of traditional media and control of what is left by a tiny number of corporations operating worldwide. Independent journalism in the mainstream is already dead and never was that more obvious than since the turn of 2020. The Cult wants all information communicated via the Internet to globally censor and allow the plug to be pulled any time. Lockdowns and forced isolation has meant that communication between people has been through electronic means and no longer through face-to-face discourse and discussion. Cult psychopaths have targeted the bars, restaurants, sport, venues and meeting places in general for this reason. None of this is by chance and it's to stop people gathering in any kind of privacy or number while being able to track and monitor all Internet communications and block them as necessary. Even private messages between individuals have been censored by these fascists that control Cult fronts like Facebook, Twitter, Google and YouTube which are all officially run by Sabbatian place-people and from the background by higher-level Sabbatian place people.

Facebook, Google, Amazon and their like were seed-funded and supported into existence with money-no-object infusions of funds either directly or indirectly from DARPA and CIA technology arm In-Q-Tel. The Cult plays the long game and prepares very carefully for big plays like 'Covid'. Amazon is another front in the psychological war and pretty much controls the global market in book sales and increasingly publishing. Amazon's limitless funds have deleted fantastic numbers of independent publishers to seize global domination on the way to deciding which books can be sold and circulated and which cannot. Moves in that direction are already happening. Amazon's leading light Jeff Bezos is the grandson of Lawrence Preston Gise who worked with DARPA predecessor ARPA. Amazon has big connections to the CIA and the Pentagon. The plan I have long described went like this:

1. Employ military technology to establish the Internet.
2. Sell the Internet as a place where people can freely communicate without censorship and allow that to happen until the Net becomes the central and irreversible pillar of human society. If the Internet had been highly censored from the start many would have rejected it.
3. Fund and manipulate major corporations into being to control the circulation of information on your Internet using cover stories about geeks in garages to explain how they came about. Give them unlimited funds to expand rapidly with no need to make a profit for years while non-Cult companies who need to balance the books cannot compete. You know that in these circumstances your Googles, YouTubes, Facebooks and Amazons are going to secure near monopolies by either crushing or buying up the opposition.
4. Allow freedom of expression on both the Internet and communication platforms to draw people in until the Internet is the central and irreversible pillar of human society and your communication corporations have reached a stage of near monopoly domination.
5. Then unleash your always-planned frenzy of censorship on the basis of 'where else are you going to go?' and continue to expand that until nothing remains that the Cult does not want its human targets to see.

The process was timed to hit the 'Covid' hoax to ensure the best chance possible of controlling the narrative which they knew they had to do at all costs. They were, after all, about to unleash a 'deadly virus' that didn't really exist. If you do that in an environment of free-flowing information and opinion you would be dead in the

water before you could say Gates is a psychopath. The network was in place through which the Cult-created-and-owned World Health Organization could dictate the 'Covid' narrative and response policy slavishly supported by Cult-owned Internet communication giants and mainstream media while those telling a different story were censored. Google, YouTube, Facebook and Twitter openly announced that they would do this. What else would we expect from Cult-owned operations like Facebook which former executives have confirmed set out to make the platform more addictive than cigarettes and coldly manipulates emotions of its users to sow division between people and groups and scramble the minds of the young? If Zuckerberg lives out the rest of his life without going to jail for crimes against humanity, and most emphatically against the young, it will be a travesty of justice. Still, no matter, cause and effect will catch up with him eventually and the same with Sergey Brin and Larry Page at Google with its CEO Sundar Pichai who fix the Google search results to promote Cult narratives and hide the opposition. Put the same key words into Google and other search engines like DuckDuckGo and you will see how different results can be. Wikipedia is another intensely biased 'encyclopaedia' which skews its content to the Cult agenda. YouTube links to Wikipedia's version of 'Covid' and 'climate change' on video pages in which experts in their field offer a different opinion (even that is increasingly rare with Wojcicki censorship). Into this 'Covid' silence-them network must be added government media censors, sorry 'regulators', such as Ofcom in the UK which imposed tyrannical restrictions on British broadcasters that had the effect of banning me from ever appearing. Just to debate with me about my evidence and views on 'Covid' would mean breaking the fascistic impositions of Ofcom and its CEO career government bureaucrat Melanie Dawes. Gutless British broadcasters tremble at the very thought of fascist Ofcom.

## **Psychos behind 'Covid'**

The reason for the 'Covid' catastrophe in all its facets and forms can be seen by whom and what is driving the policies worldwide in such a coordinated way. Decisions are not being made to protect health, but to target psychology. The dominant group guiding and 'advising' government policy are not medical professionals. They are psychologists and behavioural scientists. Every major country has its own version of this phenomenon and I'll use the British example to show how it works. In many ways the British version has been affecting the wider world in the form of the huge behaviour manipulation network in the UK which operates in other countries. The network involves private companies, government, intelligence and military. The Cabinet Office is at the centre of the government 'Covid' Psyop and part-owns, with 'innovation charity' Nesta, the Behavioural Insights Team (BIT) which claims to be independent of government but patently isn't. The BIT was established in 2010 and its job is to manipulate the psyche of the population to acquiesce to government demands and so much more. It is also known as the 'Nudge Unit', a name inspired by the 2009 book by two ultra-Zionists, Cass Sunstein and Richard Thaler, called *Nudge: Improving Decisions About Health, Wealth, and Happiness*. The book, as with the Behavioural Insights Team, seeks to 'nudge' behaviour (manipulate it) to make the public follow patterns of action and perception that suit those in authority (the Cult). Sunstein is so skilled at this that he advises the World Health Organization and the UK Behavioural Insights Team and was Administrator of the White House Office of Information and Regulatory Affairs in the Obama administration. Biden appointed him to the Department of Homeland Security – another ultra-Zionist in the fold to oversee new immigration laws which is another policy the Cult wants to control. Sunstein is desperate to silence anyone exposing conspiracies and co-authored a 2008 report on the subject in which suggestions were offered to ban 'conspiracy theorizing' or impose 'some kind of tax, financial or otherwise, on those who disseminate such theories'. I guess a psychiatrist's chair is out of the question?

Sunstein's mate Richard Thaler, an 'academic affiliate' of the UK Behavioural Insights Team, is a proponent of 'behavioural economics' which is defined as the study of 'the effects of psychological, cognitive, emotional, cultural and social factors on the decisions of individuals and institutions'. Study the effects so they can be manipulated to be what you want them to be. Other leading names in the development of behavioural economics are ultra-Zionists Daniel Kahneman and Robert J. Shiller and they, with Thaler, won the Nobel Memorial Prize in Economic Sciences for their work in this field. The Behavioural Insights Team is operating at the heart of the UK government and has expanded globally through partnerships with several universities including Harvard, Oxford, Cambridge, University College London (UCL) and Pennsylvania. They claim to have 'trained' (reframed) 20,000 civil servants and run more than 750 projects involving 400 randomised controlled trials in dozens of countries' as another version of mind reframers Common Purpose. BIT works from its office in New York with cities and their agencies, as well as other partners, across the United States and Canada – this is a company part-owned by the British government Cabinet Office. An executive order by President Cult-servant Obama established a US Social and Behavioral Sciences Team in 2015. They all have the same reason for being and that's to brainwash the population directly and by brainwashing those in positions of authority.

### **'Covid' mind game**

Another prime aspect of the UK mind-control network is the 'independent' [joke] Scientific Pandemic Insights Group on Behaviours (SPI-B) which 'provides behavioural science advice aimed at anticipating and helping people adhere to interventions that are recommended by medical or epidemiological experts'. That means manipulating public perception and behaviour to do whatever government tells them to do. It's disgusting and if they really want the public to be 'safe' this lot should all be under lock and key. According to the government website SPI-B consists of

'behavioural scientists, health and social psychologists, anthropologists and historians' and advises the Whitty-Vallance-led Scientific Advisory Group for Emergencies (SAGE) which in turn advises the government on 'the science' (it doesn't) and 'Covid' policy. When politicians say they are being guided by 'the science' this is the rabble in each country they are talking about and that 'science' is dominated by behaviour manipulators to enforce government fascism through public compliance. The Behaviour Insight Team is headed by psychologist David Solomon Halpern, a visiting professor at King's College London, and connects with a national and global web of other civilian and military organisations as the Cult moves towards its goal of fusing them into one fascistic whole in every country through its 'Fusion Doctrine'. The behaviour manipulation network involves, but is not confined to, the Foreign Office; National Security Council; government communications headquarters (GCHQ); MI5; MI6; the Cabinet Office-based Media Monitoring Unit; and the Rapid Response Unit which 'monitors digital trends to spot emerging issues; including misinformation and disinformation; and identifies the best way to respond'.

There is also the 77th Brigade of the UK military which operates like the notorious Israeli military's Unit 8200 in manipulating information and discussion on the Internet by posing as members of the public to promote the narrative and discredit those who challenge it. Here we have the military seeking to manipulate *domestic* public opinion while the Nazis in government are fine with that. Conservative Member of Parliament Tobias Ellwood, an advocate of lockdown and control through 'vaccine passports', is a Lieutenant Colonel reservist in the 77th Brigade which connects with the military operation jHub, the 'innovation centre' for the Ministry of Defence and Strategic Command. jHub has also been involved with the civilian National Health Service (NHS) in 'symptom tracing' the population. The NHS is a key part of this mind control network and produced a document in December, 2020, explaining to staff how to use psychological manipulation with different groups and ages to get them to have the DNA-manipulating 'Covid vaccine'



that's designed to cumulatively rewrite human genetics. The document, called 'Optimising Vaccination Roll Out – Do's and Don'ts for all messaging, documents and "communications" in the widest sense', was published by NHS England and the NHS Improvement *Behaviour Change Unit* in partnership with Public Health England and Warwick Business School. I hear the mantra about 'save the NHS' and 'protect the NHS' when we need to scrap the NHS and start again. The current version is far too corrupt, far too anti-human and totally compromised by Cult operatives and their assets. UK government broadcast media censor Ofcom will connect into this web – as will the BBC with its tremendous Ofcom influence – to control what the public see and hear and dictate mass perception. Nuremberg trials must include personnel from all these organisations.

### **The fear factor**

The 'Covid' hoax has led to the creation of the UK Cabinet Office-connected Joint Biosecurity Centre (JBC) which is officially described as providing 'expert advice on pandemics' using its independent [all Cult operations are 'independent'] analytical function to provide real-time analysis about infection outbreaks to identify and respond to outbreaks of Covid-19'. Another role is to advise the government on a response to spikes in infections – 'for example by closing schools or workplaces in local areas where infection levels have risen'. Put another way, promoting the Cult agenda. The Joint Biosecurity Centre is modelled on the Joint Terrorism Analysis Centre which analyses intelligence to set 'terrorism threat levels' and here again you see the fusion of civilian and military operations and intelligence that has led to military intelligence producing documents about 'vaccine hesitancy' and how it can be combated. Domestic civilian matters and opinions should not be the business of the military. The Joint Biosecurity Centre is headed by Tom Hurd, director general of the Office for Security and Counter-Terrorism from the establishment-to-its-fingertips Hurd family. His father is former Foreign Secretary Douglas Hurd. How coincidental that Tom

Hurd went to the elite Eton College and Oxford University with Boris Johnson. Imperial College with its ridiculous computer modeller Neil Ferguson will connect with this gigantic web that will itself interconnect with similar set-ups in other major and not so major countries. Compared with this Cult network the politicians, be they Boris Johnson, Donald Trump or Joe Biden, are bit-part players 'following the science'. The network of psychologists was on the 'Covid' case from the start with the aim of generating maximum fear of the 'virus' to ensure compliance by the population. A government behavioural science group known as SPI-B produced a paper in March, 2020, for discussion by the main government science advisory group known as SAGE. It was headed 'Options for increasing adherence to social distancing measures' and it said the following in a section headed 'Persuasion':

- A substantial number of people still do not feel sufficiently personally threatened; it could be that they are reassured by the low death rate in their demographic group, although levels of concern may be rising. Having a good understanding of the risk has been found to be positively associated with adoption of COVID-19 social distancing measures in Hong Kong.
- The perceived level of personal threat needs to be increased among those who are complacent, using hard-hitting evaluation of options for increasing social distancing emotional messaging. To be effective this must also empower people by making clear the actions they can take to reduce the threat.
- Responsibility to others: There seems to be insufficient understanding of, or feelings of responsibility about, people's role in transmitting the infection to others ... Messaging about actions need to be framed positively in terms of protecting oneself and the community, and increase confidence that they will be effective.
- Some people will be more persuaded by appeals to play by the rules, some by duty to the community, and some to personal risk.

All these different approaches are needed. The messaging also needs to take account of the realities of different people's lives. Messaging needs to take account of the different motivational levers and circumstances of different people.

All this could be achieved the SPI-B psychologists said by *using the media to increase the sense of personal threat* which translates as terrify the shit out of the population, including children, so they all do what we want. That's not happened has it? Those excuses for 'journalists' who wouldn't know journalism if it bit them on the arse (the great majority) have played their crucial part in serving this Cult-government Psyop to enslave their own kids and grandkids. How they live with themselves I have no idea. The psychological war has been underpinned by constant government 'Covid' propaganda in almost every television and radio ad break, plus the Internet and print media, which has pounded out the fear with taxpayers footing the bill for their own programming. The result has been people terrified of a 'virus' that doesn't exist or one with a tiny fatality rate even if you believe it does. People walk down the street and around the shops wearing face-nappies damaging their health and psychology while others report those who refuse to be that naïve to the police who turn up in their own face-nappies. I had a cameraman come to my flat and he was so frightened of 'Covid' he came in wearing a mask and refused to shake my hand in case he caught something. He had – naïveitis – and the thought that he worked in the mainstream media was both depressing and made his behaviour perfectly explainable. The fear which has gripped the minds of so many and frozen them into compliance has been carefully cultivated by these psychologists who are really psychopaths. If lives get destroyed and a lot of young people commit suicide it shows our plan is working. SPI-B then turned to compulsion on the public to comply. 'With adequate preparation, rapid change can be achieved', it said. Some countries had introduced mandatory self-isolation on a wide scale without evidence of major public unrest and a large majority of the UK's population appeared to be supportive of more coercive measures with 64 percent of adults saying they would

support putting London under a lockdown (watch the 'polls' which are designed to make people believe that public opinion is in favour or against whatever the subject in hand).

For 'aggressive protective measures' to be effective, the SPI-B paper said, special attention should be devoted to those population groups that are more at risk. Translated from the Orwellian this means making the rest of population feel guilty for not protecting the 'vulnerable' such as old people which the Cult and its agencies were about to kill on an industrial scale with lockdown, lack of treatment and the Gates 'vaccine'. Psychopath psychologists sold their guilt-trip so comprehensively that Los Angeles County Supervisor Hilda Solis reported that children were apologising (from a distance) to their parents and grandparents for bringing 'Covid' into their homes and getting them sick. '... These apologies are just some of the last words that loved ones will ever hear as they die alone,' she said. Gut-wrenchingly Solis then used this childhood tragedy to tell children to stay at home and 'keep your loved ones alive'. Imagine heaping such potentially life-long guilt on a kid when it has absolutely nothing to do with them. These people are deeply disturbed and the psychologists behind this even more so.

### **Uncivil war – divide and rule**

Professional mind-controllers at SPI-B wanted the media to increase a sense of responsibility to others (do as you're told) and promote 'positive messaging' for those actions while in contrast to invoke 'social disapproval' by the unquestioning, obedient, community of anyone with a mind of their own. Again the compliant Goebbels-like media obliged. This is an old, old, trick employed by tyrannies the world over throughout human history. You get the target population to keep the target population in line – *your* line. SPI-B said this could 'play an important role in preventing anti-social behaviour or discouraging failure to enact pro-social behaviour'. For 'anti-social' in the Orwellian parlance of SPI-B see any behaviour that government doesn't approve. SPI-B recommendations said that 'social disapproval' should be accompanied by clear messaging and

promotion of strong collective identity – hence the government and celebrity mantra of ‘we’re all in this together’. Sure we are. The mind doctors have such contempt for their targets that they think some clueless comedian, actor or singer telling them to do what the government wants will be enough to win them over. We have had UK comedian Lenny Henry, actor Michael Caine and singer Elton John wheeled out to serve the propagandists by urging people to have the DNA-manipulating ‘Covid’ non-‘vaccine’. The role of Henry and fellow black celebrities in seeking to coax a ‘vaccine’ reluctant black community into doing the government’s will was especially stomach-turning. An emotion-manipulating script and carefully edited video featuring these black ‘celebs’ was such an insult to the intelligence of black people and where’s the self-respect of those involved selling their souls to a fascist government agenda? Henry said he heard black people’s ‘legitimate worries and concerns’, but people must ‘trust the facts’ when they were doing exactly that by not having the ‘vaccine’. They had to include the obligatory reference to Black Lives Matter with the line ... ‘Don’t let coronavirus cost even more black lives – because we matter’. My god, it was pathetic. ‘I know the vaccine is safe and what it does.’ How? ‘I’m a comedian and it says so in my script.’

SPI-B said social disapproval needed to be carefully managed to avoid victimisation, scapegoating and misdirected criticism, but they knew that their ‘recommendations’ would lead to exactly that and the media were specifically used to stir-up the divide-and-conquer hostility. Those who conform like good little baa, baas, are praised while those who have seen through the tidal wave of lies are ‘Covidiot’s’. The awake have been abused by the fast asleep for not conforming to fascism and impositions that the awake know are designed to endanger their health, dehumanise them, and tear asunder the very fabric of human society. We have had the curtain-twitchers and morons reporting neighbours and others to the face-napped police for breaking ‘Covid rules’ with fascist police delighting in posting links and phone numbers where this could be done. The Cult cannot impose its will without a compliant police

and military or a compliant population willing to play their part in enslaving themselves and their kids. The words of a pastor in Nazi Germany are so appropriate today:

First they came for the socialists and I did not speak out because I was not a socialist.

Then they came for the trade unionists and I did not speak out because I was not a trade unionist.

Then they came for the Jews and I did not speak out because I was not a Jew.

Then they came for me and there was no one left to speak for me.

Those who don't learn from history are destined to repeat it and so many are.

### **'Covid' rules: Rewiring the mind**

With the background laid out to this gigantic national and global web of psychological manipulation we can put 'Covid' rules into a clear and sinister perspective. Forget the claims about protecting health. 'Covid' rules are about dismantling the human mind, breaking the human spirit, destroying self-respect, and then putting Humpty Dumpty together again as a servile, submissive slave. Social isolation through lockdown and distancing have devastating effects on the human psyche as the psychological psychopaths well know and that's the real reason for them. Humans need contact with each other, discourse, closeness and touch, or they eventually, and literally, go crazy. Masks, which I will address at some length, fundamentally add to the effects of isolation and the Cult agenda to dehumanise and de-individualise the population. To do this while knowing – in fact *seeking* – this outcome is the very epitome of evil and psychologists involved in this *are* the epitome of evil. They must like all the rest of the Cult demons and their assets stand trial for crimes against humanity on a scale that defies the imagination. Psychopaths in uniform use isolation to break enemy troops and agents and make them subservient and submissive to tell what they know. The technique is rightly considered a form of torture and

torture is most certainly what has been imposed on the human population.

Clinically-insane American psychologist Harry Harlow became famous for his isolation experiments in the 1950s in which he separated baby monkeys from their mothers and imprisoned them for months on end in a metal container or 'pit of despair'. They soon began to show mental distress and depression as any idiot could have predicted. Harlow put other monkeys in steel chambers for three, six or twelve months while denying them any contact with animals or humans. He said that the effects of total social isolation for six months were 'so devastating and debilitating that we had assumed initially that twelve months of isolation would not produce any additional decrement'; but twelve months of isolation 'almost obliterated the animals socially'. This is what the Cult and its psychopaths are doing to you and your children. Even monkeys in partial isolation in which they were not allowed to form relationships with other monkeys became 'aggressive and hostile, not only to others, but also towards their own bodies'. We have seen this in the young as a consequence of lockdown. UK government psychopaths launched a public relations campaign telling people not to hug each other even after they received the 'Covid-19 vaccine' which we were told with more lies would allow a return to 'normal life'. A government source told *The Telegraph*: 'It will be along the lines that it is great that you have been vaccinated, but if you are going to visit your family and hug your grandchildren there is a chance you are going to infect people you love.' The source was apparently speaking from a secure psychiatric facility. Janet Lord, director of Birmingham University's Institute of Inflammation and Ageing, said that parents and grandparents should avoid hugging their children. Well, how can I put it, Ms Lord? Fuck off. Yep, that'll do.

### **Destroying the kids – where are the parents?**

Observe what has happened to people enslaved and isolated by lockdown as suicide and self-harm has soared worldwide,

particularly among the young denied the freedom to associate with their friends. A study of 49,000 people in English-speaking countries concluded that almost half of young adults are at clinical risk of mental health disorders. A national survey in America of 1,000 currently enrolled high school and college students found that 5 percent reported attempting suicide during the pandemic. Data from the US CDC's National Syndromic Surveillance Program from January 1st to October 17th, 2020, revealed a 31 percent increase in mental health issues among adolescents aged 12 to 17 compared with 2019. The CDC reported that America in general suffered the biggest drop in life expectancy since World War Two as it fell by a year in the first half of 2020 as a result of 'deaths of despair' – overdoses and suicides. Deaths of despair have leapt by more than 20 percent during lockdown and include the highest number of fatal overdoses ever recorded in a single year – 81,000. Internet addiction is another consequence of being isolated at home which lowers interest in physical activities as kids fall into inertia and what's the point? Children and young people are losing hope and giving up on life, sometimes literally. A 14-year-old boy killed himself in Maryland because he had 'given up' when his school district didn't reopen; an 11-year-old boy shot himself during a zoom class; a teenager in Maine succumbed to the isolation of the 'pandemic' when he ended his life after experiencing a disrupted senior year at school. Children as young as nine have taken their life and all these stories can be repeated around the world. Careers are being destroyed before they start and that includes those in sport in which promising youngsters have not been able to take part. The plan of the psycho-psychologists is working all right. Researchers at Cambridge University found that lockdowns cause significant harm to children's mental health. Their study was published in the *Archives of Disease in Childhood*, and followed 168 children aged between 7 and 11. The researchers concluded:

During the UK lockdown, children's depression symptoms have increased substantially, relative to before lockdown. The scale of this effect has direct relevance for the continuation of different elements of lockdown policy, such as complete or partial school closures ...



... Specifically, we observed a statistically significant increase in ratings of depression, with a medium-to-large effect size. Our findings emphasise the need to incorporate the potential impact of lockdown on child mental health in planning the ongoing response to the global pandemic and the recovery from it.

Not a chance when the Cult's psycho-psychologists were getting exactly what they wanted. The UK's Royal College of Paediatrics and Child Health has urged parents to look for signs of eating disorders in children and young people after a three to four fold increase. Specialists say the 'pandemic' is a major reason behind the rise. You don't say. The College said isolation from friends during school closures, exam cancellations, loss of extra-curricular activities like sport, and an increased use of social media were all contributory factors along with fears about the virus (psycho-psychologists again), family finances, and students being forced to quarantine. Doctors said young people were becoming severely ill by the time they were seen with 'Covid' regulations reducing face-to-face consultations. Nor is it only the young that have been devastated by the psychopaths. Like all bullies and cowards the Cult is targeting the young, elderly, weak and infirm. A typical story was told by a British lady called Lynn Parker who was not allowed to visit her husband in 2020 for the last ten and half months of his life 'when he needed me most' between March 20th and when he died on December 19th. This vacates the criminal and enters the territory of evil. The emotional impact on the immune system alone is immense as are the number of people of all ages worldwide who have died as a result of Cult-demanded, Gates-demanded, lockdowns.

## **Isolation is torture**

The experience of imposing solitary confinement on millions of prisoners around the world has shown how a large percentage become 'actively psychotic and/or acutely suicidal'. Social isolation has been found to trigger 'a specific psychiatric syndrome, characterized by hallucinations; panic attacks; overt paranoia; diminished impulse control; hypersensitivity to external stimuli; and difficulties with thinking, concentration and memory'. Juan Mendez,

a United Nations rapporteur (investigator), said that isolation is a form of torture. Research has shown that even after isolation prisoners find it far more difficult to make social connections and I remember chatting to a shop assistant after one lockdown who told me that when her young son met another child again he had no idea how to act or what to do. Hannah Flanagan, Director of Emergency Services at Journey Mental Health Center in Dane County, Wisconsin, said: 'The specificity about Covid social distancing and isolation that we've come across as contributing factors to the suicides are really new to us this year.' But they are not new to those that devised them. They are getting the effect they want as the population is psychologically dismantled to be rebuilt in a totally different way. Children and the young are particularly targeted. They will be the adults when the full-on fascist AI-controlled technocracy is planned to be imposed and they are being prepared to meekly submit. At the same time older people who still have a memory of what life was like before – and how fascist the new normal really is – are being deleted. You are going to see efforts to turn the young against the old to support this geriatric genocide. Hannah Flanagan said the big increase in suicide in her county proved that social isolation is not only harmful, but deadly. Studies have shown that isolation from others is one of the main risk factors in suicide and even more so with women. Warnings that lockdown could create a 'perfect storm' for suicide were ignored. After all this was one of the *reasons* for lockdown. Suicide, however, is only the most extreme of isolation consequences. There are many others. Dr Dhruv Khullar, assistant professor of healthcare policy at Weill Cornell Medical College, said in a *New York Times* article in 2016 long before the fake 'pandemic':

A wave of new research suggests social separation is bad for us. Individuals with less social connection have disrupted sleep patterns, altered immune systems, more inflammation and higher levels of stress hormones. One recent study found that isolation increases the risk of heart disease by 29 percent and stroke by 32 percent. Another analysis that pooled data from 70 studies and 3.4 million people found that socially isolated individuals had a 30 percent higher risk of dying in the next seven years, and that this effect was largest in middle age.

Loneliness can accelerate cognitive decline in older adults, and isolated individuals are twice as likely to die prematurely as those with more robust social interactions. These effects start early: Socially isolated children have significantly poorer health 20 years later, even after controlling for other factors. All told, loneliness is as important a risk factor for early death as obesity and smoking.

There you have proof from that one article alone four years before 2020 that those who have enforced lockdown, social distancing and isolation knew what the effect would be and that is even more so with professional psychologists that have been driving the policy across the globe. We can go back even further to the years 2000 and 2003 and the start of a major study on the effects of isolation on health by Dr Janine Gronewold and Professor Dirk M. Hermann at the University Hospital in Essen, Germany, who analysed data on 4,316 people with an average age of 59 who were recruited for the long-term research project. They found that socially isolated people are more than 40 percent more likely to have a heart attack, stroke, or other major cardiovascular event and nearly 50 percent more likely to die from any cause. Given the financial Armageddon unleashed by lockdown we should note that the study found a relationship between increased cardiovascular risk and lack of financial support. After excluding other factors social isolation was still connected to a 44 percent increased risk of cardiovascular problems and a 47 percent increased risk of death by any cause. Lack of financial support was associated with a 30 percent increase in the risk of cardiovascular health events. Dr Gronewold said it had been known for some time that feeling lonely or lacking contact with close friends and family can have an impact on physical health and the study had shown that having strong social relationships is of high importance for heart health. Gronewold said they didn't understand yet why people who are socially isolated have such poor health outcomes, but this was obviously a worrying finding, particularly during these times of prolonged social distancing. Well, it can be explained on many levels. You only have to identify the point in the body where people feel loneliness and missing people they are parted from – it's in the centre of the chest where they feel the ache of loneliness and the ache of missing people. 'My heart aches for

you' ... 'My heart aches for some company.' I will explain this more in the chapter Escaping Wetiko, but when you realise that the body is the mind – they are expressions of each other – the reason why state of the mind dictates state of the body becomes clear.

American psychologist Ranjit Powar was highlighting the effects of lockdown isolation as early as April, 2020. She said humans have evolved to be social creatures and are wired to live in interactive groups. Being isolated from family, friends and colleagues could be unbalancing and traumatic for most people and could result in short or even long-term psychological and physical health problems. An increase in levels of anxiety, aggression, depression, forgetfulness and hallucinations were possible psychological effects of isolation. 'Mental conditions may be precipitated for those with underlying pre-existing susceptibilities and show up in many others without any pre-condition.' Powar said personal relationships helped us cope with stress and if we lost this outlet for letting off steam the result can be a big emotional void which, for an average person, was difficult to deal with. 'Just a few days of isolation can cause increased levels of anxiety and depression' – so what the hell has been the effect on the global population of *18 months* of this at the time of writing? Powar said: 'Add to it the looming threat of a dreadful disease being repeatedly hammered in through the media and you have a recipe for many shades of mental and physical distress.' For those with a house and a garden it is easy to forget that billions have had to endure lockdown isolation in tiny overcrowded flats and apartments with nowhere to go outside. The psychological and physical consequences of this are unimaginable and with lunatic and abusive partners and parents the consequences have led to tremendous increases in domestic and child abuse and alcoholism as people seek to shut out the horror. Ranjit Powar said:

Staying in a confined space with family is not all a rosy picture for everyone. It can be extremely oppressive and claustrophobic for large low-income families huddled together in small single-room houses. Children here are not lucky enough to have many board/electronic games or books to keep them occupied.

Add to it the deep insecurity of running out of funds for food and basic necessities. On the other hand, there are people with dysfunctional family dynamics, such as domineering, abusive or alcoholic partners, siblings or parents which makes staying home a period of trial. Incidence of suicide and physical abuse against women has shown a worldwide increase. Heightened anxiety and depression also affect a person's immune system, making them more susceptible to illness.

To think that Powar's article was published on April 11th, 2020.

## **Six-foot fantasy**

Social (unsocial) distancing demanded that people stay six feet or two metres apart. UK government advisor Robert Dingwall from the New and Emerging Respiratory Virus Threats Advisory Group said in a radio interview that the two-metre rule was 'conjured up out of nowhere' and was not based on science. No, it was not based on *medical* science, but it didn't come out of nowhere. The distance related to *psychological* science. Six feet/two metres was adopted in many countries and we were told by people like the criminal Anthony Fauci and his ilk that it was founded on science. Many schools could not reopen because they did not have the space for six-foot distancing. Then in March, 2021, after a year of six-foot 'science', a study published in the *Journal of Infectious Diseases* involving more than 500,000 students and almost 100,000 staff over 16 weeks revealed no significant difference in 'Covid' cases between six feet and three feet and Fauci changed his tune. Now three feet was okay. There is no difference between six feet and three *inches* when there is no 'virus' and they got away with six feet for psychological reasons for as long as they could. I hear journalists and others talk about 'unintended consequences' of lockdown. They are not *unintended* at all; they have been coldly-calculated for a specific outcome of human control and that's why super-psychopaths like Gates have called for them so vehemently. Super-psychopath psychologists have demanded them and psychopathic or clueless, spineless, politicians have gone along with them by 'following the science'. But it's not science at all. 'Science' is not what is; it's only what people can be manipulated to believe it is. The whole 'Covid' catastrophe is

founded on mind control. Three word or three statement mantras issued by the UK government are a well-known mind control technique and so we've had 'Stay home/protect the NHS/save lives', 'Stay alert/control the virus/save lives' and 'hands/face/space'. One of the most vocal proponents of extreme 'Covid' rules in the UK has been Professor Susan Michie, a member of the British Communist Party, who is not a medical professional. Michie is the director of the Centre for Behaviour Change at University College London. She is a *behavioural psychologist* and another filthy rich 'Marxist' who praised China's draconian lockdown. She was known by fellow students at Oxford University as 'Stalin's nanny' for her extreme Marxism. Michie is an influential member of the UK government's Scientific Advisory Group for Emergencies (SAGE) and behavioural manipulation groups which have dominated 'Covid' policy. She is a consultant adviser to the World Health Organization on 'Covid-19' and behaviour. Why the hell are lockdowns anything to do with her when they are claimed to be about health? Why does a behavioural psychologist from a group charged with changing the behaviour of the public want lockdown, human isolation and mandatory masks? Does that question really need an answer? Michie *absolutely* has to explain herself before a Nuremberg court when humanity takes back its world again and even more so when you see the consequences of masks that she demands are compulsory. This is a Michie classic:

The benefits of getting primary school children to wear masks is that regardless of what little degree of transmission is occurring in those age groups it could help normalise the practice. Young children wearing masks may be more likely to get their families to accept masks.

Those words alone should carry a prison sentence when you ponder on the callous disregard for children involved and what a statement it makes about the mind and motivations of Susan Michie. What a lovely lady and what she said there encapsulates the mentality of the psychopaths behind the 'Covid' horror. Let us compare what Michie said with a countrywide study in Germany published at [researchsquare.com](https://www.researchsquare.com) involving 25,000 school children and 17,854 health complaints submitted by parents. Researchers

found that masks are harming children physically, psychologically, and behaviourally with 24 health issues associated with mask wearing. They include: shortness of breath (29.7%); dizziness (26.4%); increased headaches (53%); difficulty concentrating (50%); drowsiness or fatigue (37%); and malaise (42%). Nearly a third of children experienced more sleep issues than before and a quarter developed new fears. Researchers found health issues and other impairments in 68 percent of masked children covering their faces for an average of 4.5 hours a day. Hundreds of those taking part experienced accelerated respiration, tightness in the chest, weakness, and short-term impairment of consciousness. A reminder of what Michie said again:

The benefits of getting primary school children to wear masks is that regardless of what little degree of transmission is occurring in those age groups it could help normalise the practice. Young children wearing masks may be more likely to get their families to accept masks.

Psychopaths in government and psychology now have children and young people – plus all the adults – wearing masks for hours on end while clueless teachers impose the will of the psychopaths on the young they should be protecting. What the hell are parents doing?

## **Cult lab rats**

We have some schools already imposing on students microchipped buzzers that activate when they get 'too close' to their pals in the way they do with lab rats. How apt. To the Cult and its brain-dead servants our children *are* lab rats being conditioned to be unquestioning, dehumanised slaves for the rest of their lives. Children and young people are being weaned and frightened away from the most natural human instincts including closeness and touch. I have tracked in the books over the years how schools were banning pupils from greeting each other with a hug and the whole Cult-induced Me Too movement has terrified men and boys from a relaxed and natural interaction with female friends and work colleagues to the point where many men try never to be in a room

alone with a woman that's not their partner. Airhead celebrities have as always played their virtue-signalling part in making this happen with their gross exaggeration. For every monster like Harvey Weinstein there are at least tens of thousands of men that don't treat women like that; but everyone must be branded the same and policy changed for them as well as the monster. I am going to be using the word 'dehumanise' many times in this chapter because that is what the Cult is seeking to do and it goes very deep as we shall see. Don't let them kid you that social distancing is planned to end one day. That's not the idea. We are seeing more governments and companies funding and producing wearable gadgets to keep people apart and they would not be doing that if this was meant to be short-term. A tech start-up company backed by GCHQ, the British Intelligence and military surveillance headquarters, has created a social distancing wrist sensor that alerts people when they get too close to others. The CIA has also supported tech companies developing similar devices. The wearable sensor was developed by Tended, one of a number of start-up companies supported by GCHQ (see the CIA and DARPA). The device can be worn on the wrist or as a tag on the waistband and will vibrate whenever someone wearing the device breaches social distancing and gets anywhere near natural human contact. The company had a lucky break in that it was developing a distancing sensor when the 'Covid' hoax arrived which immediately provided a potentially enormous market. How fortunate. The government in big-time Cult-controlled Ontario in Canada is investing \$2.5 million in wearable contact tracing technology that 'will alert users if they may have been exposed to the Covid-19 in the workplace and will beep or vibrate if they are within six feet of another person'. Facedrive Inc., the technology company behind this, was founded in 2016 with funding from the Ontario Together Fund and obviously they, too, had a prophet on the board of directors. The human surveillance and control technology is called TraceSCAN and would be worn by the human cyborgs in places such as airports, workplaces, construction sites, care homes and ... *schools*.



I emphasise schools with children and young people the prime targets. You know what is planned for society as a whole if you keep your eyes on the schools. They have always been places where the state program the next generation of slaves to be its compliant worker-ants – or Woker-ants these days; but in the mist of the ‘Covid’ madness they have been transformed into mind laboratories on a scale never seen before. Teachers and head teachers are just as programmed as the kids – often more so. Children are kept apart from human interaction by walk lanes, classroom distancing, staggered meal times, masks, and the rolling-out of buzzer systems. Schools are now physically laid out as a laboratory maze for lab-rats. Lunatics at a school in Anchorage, Alaska, who should be prosecuted for child abuse, took away desks and forced children to kneel (know your place) on a mat for five hours a day while wearing a mask and using their chairs as a desk. How this was supposed to impact on a ‘virus’ only these clinically insane people can tell you and even then it would be clap-trap. The school banned recess (interaction), art classes (creativity), and physical exercise (getting body and mind moving out of inertia). Everyone behind this outrage should be in jail or better still a mental institution. The behavioural manipulators are all for this dystopian approach to schools. Professor Susan Michie, the mind-doctor and British Communist Party member, said it was wrong to say that schools were safe. They had to be made so by ‘distancing’, masks and ventilation (sitting all day in the cold). I must ask this lady round for dinner on a night I know I am going to be out and not back for weeks. She probably wouldn’t be able to make it, anyway, with all the visits to her own psychologist she must have block-booked.

## **Masking identity**

I know how shocking it must be for you that a behaviour manipulator like Michie wants everyone to wear masks which have long been a feature of mind-control programs like the infamous MKUltra in the United States, but, there we are. We live and learn. I spent many years from 1996 to right across the millennium

researching mind control in detail on both sides of the Atlantic and elsewhere. I met a large number of mind-control survivors and many had been held captive in body and mind by MKUltra. MK stands for mind-control, but employs the German spelling in deference to the Nazis spirited out of Germany at the end of World War Two by Operation Paperclip in which the US authorities, with help from the Vatican, transported Nazi mind-controllers and engineers to America to continue their work. Many of them were behind the creation of NASA and they included Nazi scientist and SS officer Wernher von Braun who swapped designing V-2 rockets to bombard London with designing the Saturn V rockets that powered the NASA moon programme's Apollo craft. I think I may have mentioned that the Cult has no borders. Among Paperclip escapees was Josef Mengele, the Angel of Death in the Nazi concentration camps where he conducted mind and genetic experiments on children often using twins to provide a control twin to measure the impact of his 'work' on the other. If you want to observe the Cult mentality in all its extremes of evil then look into the life of Mengele. I have met many people who suffered mercilessly under Mengele in the United States where he operated under the name Dr Greene and became a stalwart of MKUltra programming and torture. Among his locations was the underground facility in the Mojave Desert in California called the China Lake Naval Weapons Station which is almost entirely below the surface. My books *The Biggest Secret*, *Children of the Matrix* and *The Perception Deception* have the detailed background to MKUltra.

The best-known MKUltra survivor is American Cathy O'Brien. I first met her and her late partner Mark Phillips at a conference in Colorado in 1996. Mark helped her escape and deprogram from decades of captivity in an offshoot of MKUltra known as Project Monarch in which 'sex slaves' were provided for the rich and famous including Father George Bush, Dick Cheney and the Clintons. Read Cathy and Mark's book *Trance-Formation of America* and if you are new to this you will be shocked to the core. I read it in 1996 shortly before, with the usual synchronicity of my life, I found

myself given a book table at the conference right next to hers. MKUltra never ended despite being very publicly exposed (only a small part of it) in the 1970s and continues in other guises. I am still in touch with Cathy. She contacted me during 2020 after masks became compulsory in many countries to tell me how they were used as part of MKUltra programming. I had been observing 'Covid regulations' and the relationship between authority and public for months. I saw techniques that I knew were employed on individuals in MKUltra being used on the global population. I had read many books and manuals on mind control including one called *Silent Weapons for Quiet Wars* which came to light in the 1980s and was a guide on how to perceptually program on a mass scale. 'Silent Weapons' refers to mind-control. I remembered a line from the manual as governments, medical authorities and law enforcement agencies have so obviously talked to – or rather at – the adult population since the 'Covid' hoax began as if they are children. The document said:

If a person is spoken to by a T.V. advertiser as if he were a twelve-year-old, then, due to suggestibility, he will, with a certain probability, respond or react to that suggestion with the uncritical response of a twelve-year-old and will reach in to his economic reservoir and deliver its energy to buy that product on impulse when he passes it in the store.

That's why authority has spoken to adults like children since all this began.

### **Why did Michael Jackson wear masks?**

Every aspect of the 'Covid' narrative has mind-control as its central theme. Cathy O'Brien wrote an article for [davidicke.com](http://davidicke.com) about the connection between masks and mind control. Her daughter Kelly who I first met in the 1990s was born while Cathy was still held captive in MKUltra. Kelly was forced to wear a mask as part of her programming from the age of *two* to dehumanise her, target her sense of individuality and reduce the amount of oxygen her brain and body received. *Bingo*. This is the real reason for compulsory

masks, why they have been enforced en masse, and why they seek to increase the number they demand you wear. First one, then two, with one disgraceful alleged 'doctor' recommending four which is nothing less than a death sentence. Where and how often they must be worn is being expanded for the purpose of mass mind control and damaging respiratory health which they can call 'Covid-19'. Canada's government headed by the man-child Justin Trudeau, says it's fine for children of two and older to wear masks. An insane 'study' in Italy involving just 47 children concluded there was no problem for babies as young as *four months* wearing them. Even after people were 'vaccinated' they were still told to wear masks by the criminal that is Anthony Fauci. Cathy wrote that mandating masks is allowing the authorities literally to control the air we breathe which is what was done in MKUltra. You might recall how the singer Michael Jackson wore masks and there is a reason for that. He was subjected to MKUltra mind control through Project Monarch and his psyche was scrambled by these simpletons. Cathy wrote:

In MKUltra Project Monarch mind control, Michael Jackson had to wear a mask to silence his voice so he could not reach out for help. Remember how he developed that whisper voice when he wasn't singing? Masks control the mind from the outside in, like the redefining of words is doing. By controlling what we can and cannot say for fear of being labeled racist or beaten, for example, it ultimately controls thought that drives our words and ultimately actions (or lack thereof).

Likewise, a mask muffles our speech so that we are not heard, which controls voice ... words ... mind. This is Mind Control. Masks are an obvious mind control device, and I am disturbed so many people are complying on a global scale. Masks depersonalize while making a person feel as though they have no voice. It is a barrier to others. People who would never choose to comply but are forced to wear a mask in order to keep their job, and ultimately their family fed, are compromised. They often feel shame and are subdued. People have stopped talking with each other while media controls the narrative.

The 'no voice' theme has often become literal with train passengers told not to speak to each other in case they pass on the 'virus', singing banned for the same reason and bonkers California officials telling people riding roller coasters that they cannot shout and scream. Cathy said she heard every day from healed MKUltra survivors who cannot wear a mask without flashing back on ways

their breathing was controlled – ‘from ball gags and penises to water boarding’. She said that through the years when she saw images of people in China wearing masks ‘due to pollution’ that it was really to control their oxygen levels. ‘I knew it was as much of a population control mechanism of depersonalisation as are burkas’, she said. Masks are another Chinese communist/fascist method of control that has been swept across the West as the West becomes China at lightning speed since we entered 2020.

## **Mask-19**

There are other reasons for mandatory masks and these include destroying respiratory health to call it ‘Covid-19’ and stunting brain development of children and the young. Dr Margarite Griesz-Brisson MD, PhD, is a Consultant Neurologist and Neurophysiologist and the Founder and Medical Director of the London Neurology and Pain Clinic. Her CV goes down the street and round the corner. She is clearly someone who cares about people and won’t parrot the propaganda. Griesz-Brisson has a PhD in pharmacology, with special interest in neurotoxicology, environmental medicine, neuroregeneration and neuroplasticity (the way the brain can change in the light of information received). She went public in October, 2020, with a passionate warning about the effects of mask-wearing laws:

The reinhalation of our exhaled air will without a doubt create oxygen deficiency and a flooding of carbon dioxide. We know that the human brain is very sensitive to oxygen deprivation. There are nerve cells for example in the hippocampus that can’t be longer than 3 minutes without oxygen – they cannot survive. The acute warning symptoms are headaches, drowsiness, dizziness, issues in concentration, slowing down of reaction time – reactions of the cognitive system.

Oh, I know, let’s tell bus, truck and taxi drivers to wear them and people working machinery. How about pilots, doctors and police? Griesz-Brisson makes the important point that while the symptoms she mentions may fade as the body readjusts this does not alter the fact that people continue to operate in oxygen deficit with long list of

potential consequences. She said it was well known that neurodegenerative diseases take years or decades to develop. 'If today you forget your phone number, the breakdown in your brain would have already started 20 or 30 years ago.' She said degenerative processes in your brain are getting amplified as your oxygen deprivation continues through wearing a mask. Nerve cells in the brain are unable to divide themselves normally in these circumstances and lost nerve cells will no longer be regenerated. 'What is gone is gone.' Now consider that people like shop workers and *schoolchildren* are wearing masks for hours every day. What in the name of sanity is going to be happening to them? 'I do not wear a mask, I need my brain to think', Griesz-Brisson said, 'I want to have a clear head when I deal with my patients and not be in a carbon dioxide-induced anaesthesia'. If you are told to wear a mask anywhere ask the organisation, police, store, whatever, for their risk assessment on the dangers and negative effects on mind and body of enforcing mask-wearing. They won't have one because it has never been done not even by government. All of them must be subject to class-action lawsuits as the consequences come to light. They don't do mask risk assessments for an obvious reason. They know what the conclusions would be and independent scientific studies that *have* been done tell a horror story of consequences.

### **'Masks are criminal'**

Dr Griesz-Brisson said that for children and adolescents, masks are an absolute no-no. They had an extremely active and adaptive immune system and their brain was incredibly active with so much to learn. 'The child's brain, or the youth's brain, is thirsting for oxygen.' The more metabolically active an organ was, the more oxygen it required; and in children and adolescents every organ was metabolically active. Griesz-Brisson said that to deprive a child's or adolescent's brain of oxygen, or to restrict it in any way, was not only dangerous to their health, it was absolutely criminal. 'Oxygen deficiency inhibits the development of the brain, and the damage that has taken place as a result CANNOT be reversed.' Mind

manipulators of MKUltra put masks on two-year-olds they wanted to neurologically rewire and you can see why. Griesz-Brisson said a child needs the brain to learn and the brain needs oxygen to function. 'We don't need a clinical study for that. This is simple, indisputable physiology.' Consciously and purposely induced oxygen deficiency was an absolutely deliberate health hazard, and an absolute medical contraindication which means that 'this drug, this therapy, this method or measure should not be used, and is not allowed to be used'. To coerce an entire population to use an absolute medical contraindication by force, she said, there had to be definite and serious reasons and the reasons must be presented to competent interdisciplinary and independent bodies to be verified and authorised. She had this warning of the consequences that were coming if mask wearing continued:

When, in ten years, dementia is going to increase exponentially, and the younger generations couldn't reach their god-given potential, it won't help to say 'we didn't need the masks'. I know how damaging oxygen deprivation is for the brain, cardiologists know how damaging it is for the heart, pulmonologists know how damaging it is for the lungs. Oxygen deprivation damages every single organ. Where are our health departments, our health insurance, our medical associations? It would have been their duty to be vehemently against the lockdown and to stop it and stop it from the very beginning.

Why do the medical boards issue punishments to doctors who give people exemptions? Does the person or the doctor seriously have to prove that oxygen deprivation harms people? What kind of medicine are our doctors and medical associations representing? Who is responsible for this crime? The ones who want to enforce it? The ones who let it happen and play along, or the ones who don't prevent it?

All of the organisations and people she mentions there either answer directly to the Cult or do whatever hierarchical levels above them tell them to do. The outcome of both is the same. 'It's not about masks, it's not about viruses, it's certainly not about your health', Griesz-Brisson said. 'It is about much, much more. I am not participating. I am not afraid.' They were taking our air to breathe and there was no unfounded medical exemption from face masks. Oxygen deprivation was dangerous for every single brain. It had to be the free decision of every human being whether they want to

wear a mask that was absolutely ineffective to protect themselves from a virus. She ended by rightly identifying where the responsibility lies for all this:

The imperative of the hour is personal responsibility. We are responsible for what we think, not the media. We are responsible for what we do, not our superiors. We are responsible for our health, not the World Health Organization. And we are responsible for what happens in our country, not the government.

Halle-bloody-lujah.

### **But surgeons wear masks, right?**

Independent studies of mask-wearing have produced a long list of reports detailing mental, emotional and physical dangers. What a definition of insanity to see police officers imposing mask-wearing on the public which will cumulatively damage their health while the police themselves wear masks that will cumulatively damage *their* health. It's utter madness and both public and police do this because 'the government says so' – yes a government of brain-donor idiots like UK Health Secretary Matt Hancock reading the 'follow the science' scripts of psychopathic, lunatic psychologists. The response you get from Stockholm syndrome sufferers defending the very authorities that are destroying them and their families is that 'surgeons wear masks'. This is considered the game, set and match that they must work and don't cause oxygen deficit. Well, actually, scientific studies have shown that they *do* and oxygen levels are monitored in operating theatres to compensate. Surgeons wear masks to stop spittle and such like dropping into open wounds – not to stop 'viral particles' which are so miniscule they can only be seen through an electron microscope. Holes in the masks are significantly bigger than 'viral particles' and if you sneeze or cough they will breach the mask. I watched an incredibly disingenuous 'experiment' that claimed to prove that masks work in catching 'virus' material from the mouth and nose. They did this with a slow motion camera and the mask did block big stuff which stayed inside the mask and



against the face to be breathed in or cause infections on the face as we have seen with many children. 'Viral particles', however, would never have been picked up by the camera as they came through the mask when they are far too small to be seen. The 'experiment' was therefore disingenuous *and* useless.

Studies have concluded that wearing masks in operating theatres (and thus elsewhere) make no difference to preventing infection while the opposite is true with toxic shite building up in the mask and this had led to an explosion in tooth decay and gum disease dubbed by dentists 'mask mouth'. You might have seen the Internet video of a furious American doctor urging people to take off their masks after a four-year-old patient had been rushed to hospital the night before and nearly died with a lung infection that doctors sourced to mask wearing. A study in the journal *Cancer Discovery* found that inhalation of harmful microbes can contribute to advanced stage lung cancer in adults and long-term use of masks can help breed dangerous pathogens. Microbiologists have said frequent mask wearing creates a moist environment in which microbes can grow and proliferate before entering the lungs. The Canadian Agency for Drugs and Technologies in Health, or CADTH, a Canadian national organisation that provides research and analysis to healthcare decision-makers, said this as long ago as 2013 in a report entitled 'Use of Surgical Masks in the Operating Room: A Review of the Clinical Effectiveness and Guidelines'. It said:

- No evidence was found to support the use of surgical face masks to reduce the frequency of surgical site infections
- No evidence was found on the effectiveness of wearing surgical face masks to protect staff from infectious material in the operating room.
- Guidelines recommend the use of surgical face masks by staff in the operating room to protect both operating room staff and patients (despite the lack of evidence).

We were told that the world could go back to 'normal' with the arrival of the 'vaccines'. When they came, fraudulent as they are, the story changed as I knew that it would. We are in the midst of transforming 'normal', not going back to it. Mary Ramsay, head of immunisation at Public Health England, echoed the words of US criminal Anthony Fauci who said masks and other regulations must stay no matter if people are vaccinated. The Fauci idiot continued to wear two masks – different colours so both could be clearly seen – after he *claimed* to have been vaccinated. Senator Rand Paul told Fauci in one exchange that his double-masks were 'theatre' and he was right. It's all theatre. Mary Ramsay back-tracked on the vaccine-return-to-normal theme when she said the public may need to wear masks and social-distance for years despite the jabs. 'People have got used to those lower-level restrictions now, and [they] can live with them', she said telling us what the idea has been all along. 'The vaccine does not give you a pass, even if you have had it, you must continue to follow all the guidelines' said a Public Health England statement which reneged on what we had been told before and made having the 'vaccine' irrelevant to 'normality' even by the official story. Spain's fascist government trumped everyone by passing a law mandating the wearing of masks on the beach and even when swimming in the sea. The move would have devastated what's left of the Spanish tourist industry, posed potential breathing dangers to swimmers and had Northern European sunbathers walking around with their forehead brown and the rest of their face white as a sheet. The ruling was so crazy that it had to be retracted after pressure from public and tourist industry, but it confirmed where the Cult wants to go with masks and how clinically insane authority has become. The determination to make masks permanent and hide the serious dangers to body and mind can be seen in the censorship of scientist Professor Denis Rancourt by Bill Gates-funded academic publishing website ResearchGate over his papers exposing the dangers and uselessness of masks. Rancourt said:

ResearchGate today has permanently locked my account, which I have had since 2015. Their reasons graphically show the nature of their attack against democracy, and their corruption of

science ... By their obscene non-logic, a scientific review of science articles reporting on harms caused by face masks has a 'potential to cause harm'. No criticism of the psychological device (face masks) is tolerated, if the said criticism shows potential to influence public policy.

This is what happens in a fascist world.

### **Where are the 'greens' (again)?**

Other dangers of wearing masks especially regularly relate to the inhalation of minute plastic fibres into the lungs and the deluge of discarded masks in the environment and oceans. Estimates predicted that more than 1.5 billion disposable masks will end up in the world's oceans every year polluting the water with tons of plastic and endangering marine wildlife. Studies project that humans are using 129 billion face masks each month worldwide – about three million a minute. Most are disposable and made from plastic, non-biodegradable microfibers that break down into smaller plastic particles that become widespread in ecosystems. They are littering cities, clogging sewage channels and turning up in bodies of water. I have written in other books about the immense amounts of microplastics from endless sources now being absorbed into the body. Rolf Halden, director of the Arizona State University (ASU) Biodesign Center for Environmental Health Engineering, was the senior researcher in a 2020 study that analysed 47 human tissue samples and found microplastics in all of them. 'We have detected these chemicals of plastics in every single organ that we have investigated', he said. I wrote in *The Answer* about the world being deluged with microplastics. A study by the Worldwide Fund for Nature (WWF) found that people are consuming on average every week some 2,000 tiny pieces of plastic mostly through water and also through marine life and the air. Every year humans are ingesting enough microplastics to fill a heaped dinner plate and in a life-time of 79 years it is enough to fill two large waste bins. Marco Lambertini, WWF International director general said: 'Not only are plastics polluting our oceans and waterways and killing marine life – it's in all of us and we can't escape consuming plastics,' American

geologists found tiny plastic fibres, beads and shards in rainwater samples collected from the remote slopes of the Rocky Mountain National Park near Denver, Colorado. Their report was headed: 'It is raining plastic.' Rachel Adams, senior lecturer in Biomedical Science at Cardiff Metropolitan University, said that among health consequences are internal inflammation and immune responses to a 'foreign body'. She further pointed out that microplastics become carriers of toxins including mercury, pesticides and dioxins (a known cause of cancer and reproductive and developmental problems). These toxins accumulate in the fatty tissues once they enter the body through microplastics. Now this is being compounded massively by people putting plastic on their face and throwing it away.

Workers exposed to polypropylene plastic fibres known as 'flock' have developed 'flock worker's lung' from inhaling small pieces of the flock fibres which can damage lung tissue, reduce breathing capacity and exacerbate other respiratory problems. *Now ...* commonly used surgical masks have three layers of melt-blown textiles made of ... polypropylene. We have billions of people putting these microplastics against their mouth, nose and face for hours at a time day after day in the form of masks. How does anyone think that will work out? I mean – what could possibly go wrong? We posted a number of scientific studies on this at [davidicke.com](http://davidicke.com), but when I went back to them as I was writing this book the links to the science research website where they were hosted were dead. Anything that challenges the official narrative in any way is either censored or vilified. The official narrative is so unsupportable by the evidence that only deleting the truth can protect it. A study by Chinese scientists still survived – with the usual twist which it why it was still active, I guess. Yes, they found that virtually all the masks they tested increased the daily intake of microplastic fibres, but people should still wear them because the danger from the 'virus' was worse said the crazy 'team' from the Institute of Hydrobiology in Wuhan. Scientists first discovered microplastics in lung tissue of some patients who died of lung cancer

in the 1990s. Subsequent studies have confirmed the potential health damage with the plastic degrading slowly and remaining in the lungs to accumulate in volume. Wuhan researchers used a machine simulating human breathing to establish that masks shed up to nearly 4,000 microplastic fibres in a month with reused masks producing more. Scientists said some masks are laced with toxic chemicals and a variety of compounds seriously restricted for both health and environmental reasons. They include cobalt (used in blue dye) and formaldehyde known to cause watery eyes, burning sensations in the eyes, nose, and throat, plus coughing, wheezing and nausea. No – that must be ‘Covid-19’.

### **Mask ‘worms’**

There is another and potentially even more sinister content of masks. Mostly new masks of different makes filmed under a microscope around the world have been found to contain strange black fibres or ‘worms’ that appear to move or ‘crawl’ by themselves and react to heat and water. The nearest I have seen to them are the self-replicating fibres that are pulled out through the skin of those suffering from Morgellons disease which has been connected to the phenomena of ‘chemtrails’ which I will bring into the story later on. Morgellons fibres continue to grow outside the body and have a form of artificial intelligence. Black ‘worm’ fibres in masks have that kind of feel to them and there is a nanotechnology technique called ‘worm micelles’ which carry and release drugs or anything else you want to deliver to the body. For sure the suppression of humanity by mind altering drugs is the Cult agenda big time and the more excuses they can find to gain access to the body the more opportunities there are to make that happen whether through ‘vaccines’ or masks pushed against the mouth and nose for hours on end.

So let us summarise the pros and cons of masks:

*Against masks:* Breathing in your own carbon dioxide; depriving the body and brain of sufficient oxygen; build-up of toxins in the mask that can be breathed into the lungs and cause rashes on the face and 'mask-mouth'; breathing microplastic fibres and toxic chemicals into the lungs; dehumanisation and deleting individualisation by literally making people faceless; destroying human emotional interaction through facial expression and deleting parental connection with their babies which look for guidance to their facial expression.

*For masks:* They don't protect you from a 'virus' that doesn't exist and even if it did 'viral' particles are so minute they are smaller than the holes in the mask.

Governments, police, supermarkets, businesses, transport companies, and all the rest who seek to impose masks have done no risk assessment on their consequences for health and psychology and are now open to group lawsuits when the impact becomes clear with a cumulative epidemic of respiratory and other disease. Authorities will try to exploit these effects and hide the real cause by dubbing them 'Covid-19'. Can you imagine setting out to force the population to wear health-destroying masks without doing any assessment of the risks? It is criminal and it is evil, but then how many people targeted in this way, who see their children told to wear them all day at school, have asked for a risk assessment? Billions can't be imposed upon by the few unless the billions allow it. Oh, yes, with just a tinge of irony, 85 percent of all masks made worldwide come from *China*.

### **Wash your hands in toxic shite**

'Covid' rules include the use of toxic sanitisers and again the health consequences of constantly applying toxins to be absorbed through the skin is obvious to any level of Renegade Mind. America's Food and Drug Administration (FDA) said that sanitisers are drugs and issued a warning about 75 dangerous brands which contain

methanol used in antifreeze and can cause death, kidney damage and blindness. The FDA circulated the following warning even for those brands that it claims to be safe:

Store hand sanitizer out of the reach of pets and children, and children should use it only with adult supervision. Do not drink hand sanitizer. This is particularly important for young children, especially toddlers, who may be attracted by the pleasant smell or brightly colored bottles of hand sanitizer.

Drinking even a small amount of hand sanitizer can cause alcohol poisoning in children. (However, there is no need to be concerned if your children eat with or lick their hands after using hand sanitizer.) During this coronavirus pandemic, poison control centers have had an increase in calls about accidental ingestion of hand sanitizer, so it is important that adults monitor young children's use.

Do not allow pets to swallow hand sanitizer. If you think your pet has eaten something potentially dangerous, call your veterinarian or a pet poison control center right away. Hand sanitizer is flammable and should be stored away from heat and flames. When using hand sanitizer, rub your hands until they feel completely dry before performing activities that may involve heat, sparks, static electricity, or open flames.

There you go, perfectly safe, then, and that's without even a mention of the toxins absorbed through the skin. Come on kids – sanitise your hands everywhere you go. It will save you from the 'virus'. Put all these elements together of the 'Covid' normal and see how much health and psychology is being cumulatively damaged, even devastated, to 'protect your health'. Makes sense, right? They are only imposing these things because they care, right? *Right?*

## **Submitting to insanity**

Psychological reframing of the population goes very deep and is done in many less obvious ways. I hear people say how contradictory and crazy 'Covid' rules are and how they are ever changing. This is explained away by dismissing those involved as idiots. It is a big mistake. The Cult is delighted if its cold calculation is perceived as incompetence and idiocy when it is anything but. Oh, yes, there are idiots within the system – lots of them – but they are *administering* the Cult agenda, mostly unknowingly. They are not deciding and dictating it. The bulwark against tyranny is self-

respect, always has been, always will be. It is self-respect that has broken every tyranny in history. By its very nature self-respect will not bow to oppression and its perpetrators. There is so little self-respect that it's always the few that overturn dictators. Many may eventually follow, but the few with the iron spines (self-respect) kick it off and generate the momentum. The Cult targets self-respect in the knowledge that once this has gone only submission remains. Crazy, contradictory, ever-changing 'Covid' rules are systematically applied by psychologists to delete self-respect. They *want* you to see that the rules make no sense. It is one thing to decide to do something when *you* have made the choice based on evidence and logic. You still retain your self-respect. It is quite another when you can see what you are being told to do is insane, ridiculous and makes no sense, and *yet you still do it*. Your self-respect is extinguished and this has been happening as ever more obviously stupid and nonsensical things have been demanded and the great majority have complied even when they can see they are stupid and nonsensical.

People walk around in face-nappies knowing they are damaging their health and make no difference to a 'virus'. They do it in fear of not doing it. I know it's daft, but I'll do it anyway. When that happens something dies inside of you and submissive reframing has begun. Next there's a need to hide from yourself that you have conceded your self-respect and you convince yourself that you have not really submitted to fear and intimidation. You begin to believe that you are complying with craziness because it's the right thing to do. When first you concede your self-respect of  $2+2 = 4$  to  $2+2 = 5$  you *know* you are compromising your self-respect. Gradually to avoid facing that fact you begin to *believe* that  $2+2=5$ . You have been reframed and I have been watching this process happening in the human psyche on an industrial scale. The Cult is working to break your spirit and one of its major tools in that war is humiliation. I read how former American soldier Bradley Manning (later Chelsea Manning after a sex-change) was treated after being jailed for supplying WikiLeaks with documents exposing the enormity of



government and elite mendacity. Manning was isolated in solitary confinement for eight months, put under 24-hour surveillance, forced to hand over clothing before going to bed, and stand naked for every roll call. This is systematic humiliation. The introduction of anal swab 'Covid' tests in China has been done for the same reason to delete self-respect and induce compliant submission. Anal swabs are mandatory for incoming passengers in parts of China and American diplomats have said they were forced to undergo the indignity which would have been calculated humiliation by the Cult-owned Chinese government that has America in its sights.

### **Government-people: An abusive relationship**

Spirit-breaking psychological techniques include giving people hope and apparent respite from tyranny only to take it away again. This happened in the UK during Christmas, 2020, when the psycho-psychologists and their political lackeys announced an easing of restrictions over the holiday only to reimpose them almost immediately on the basis of yet another lie. There is a big psychological difference between getting used to oppression and being given hope of relief only to have that dashed. Psychologists know this and we have seen the technique used repeatedly. Then there is traumatising people before you introduce more extreme regulations that require compliance. A perfect case was the announcement by the dark and sinister Whitty and Vallance in the UK that 'new data' predicted that 4,000 could die every day over the winter of 2020/2021 if we did not lockdown again. I think they call it lying and after traumatising people with that claim out came Jackboot Johnson the next day with new curbs on human freedom. Psychologists know that a frightened and traumatised mind becomes suggestable to submission and behaviour reframing. Underpinning all this has been to make people fearful and suspicious of each other and see themselves as a potential danger to others. In league with deleted self-respect you have the perfect psychological recipe for self-loathing. The relationship between authority and public is now demonstrably the same as that of

subservience to an abusive partner. These are signs of an abusive relationship explained by psychologist Leslie Becker-Phelps:

**Psychological and emotional abuse:** Undermining a partner's self-worth with verbal attacks, name-calling, and belittling. Humiliating the partner in public, unjustly accusing them of having an affair, or interrogating them about their every behavior. Keeping partner confused or off balance by saying they were just kidding or blaming the partner for 'making' them act this way ... Feigning in public that they care while turning against them in private. This leads to victims frequently feeling confused, incompetent, unworthy, hopeless, and chronically self-doubting. [Apply these techniques to how governments have treated the population since New Year, 2020, and the parallels are obvious.]

**Physical abuse:** The abuser might physically harm their partner in a range of ways, such as grabbing, hitting, punching, or shoving them. They might throw objects at them or harm them with a weapon. [Observe the physical harm imposed by masks, lockdown, and so on.]

**Threats and intimidation:** One way abusers keep their partners in line is by instilling fear. They might be verbally threatening, or give threatening looks or gestures. Abusers often make it known that they are tracking their partner's every move. They might destroy their partner's possessions, threaten to harm them, or threaten to harm their family members. Not surprisingly, victims of this abuse often feel anxiety, fear, and panic. [No words necessary.]

**Isolation:** Abusers often limit their partner's activities, forbidding them to talk or interact with friends or family. They might limit access to a car or even turn off their phone. All of this might be done by physically holding them against their will, but is often accomplished through psychological abuse and intimidation. The more isolated a person feels, the fewer resources they have to help gain perspective on their situation and to escape from it. [No words necessary.]

**Economic abuse:** Abusers often make their partners beholden to them for money by controlling access to funds of any kind. They might prevent their partner from getting a job or withhold access to money they earn from a job. This creates financial dependency that makes leaving the relationship very difficult. [See destruction of livelihoods and the proposed meagre 'guaranteed income' so long as you do whatever you are told.]

**Using children:** An abuser might disparage their partner's parenting skills, tell their children lies about their partner, threaten to take custody of their children, or threaten to harm their children. These tactics instil fear and often elicit compliance. [See reframed social service mafia and how children are being mercilessly abused by the state over 'Covid' while their parents look on too frightened to do anything.]

A further recurring trait in an abusive relationship is the abused blaming themselves for their abuse and making excuses for the abuser. We have the public blaming each other for lockdown abuse by government and many making excuses for the government while attacking those who challenge the government. How often we have heard authorities say that rules are being imposed or reimposed only because people have refused to 'behave' and follow the rules. We don't want to do it – it's *you*.

Renegade Minds are an antidote to all of these things. They will never concede their self-respect no matter what the circumstances. Even when apparent humiliation is heaped upon them they laugh in its face and reflect back the humiliation on the abuser where it belongs. Renegade Minds will never wear masks they know are only imposed to humiliate, suppress and damage both physically and psychologically. Consequences will take care of themselves and they will never break their spirit or cause them to concede to tyranny. UK newspaper columnist Peter Hitchens was one of the few in the mainstream media to speak out against lockdowns and forced vaccinations. He then announced he had taken the jab. He wanted to see family members abroad and he believed vaccine passports were inevitable even though they had not yet been introduced. Hitchens

has a questioning and critical mind, but not a Renegade one. If he had no amount of pressure would have made him concede. Hitchens excused his action by saying that the battle has been lost. Renegade Minds never accept defeat when freedom is at stake and even if they are the last one standing the self-respect of not submitting to tyranny is more important than any outcome or any consequence.

That's why Renegade Minds are the only minds that ever changed anything worth changing.

## CHAPTER EIGHT

### **'Reframing' insanity**

*Insanity is relative. It depends on who has who locked in what cage*  
Ray Bradbury

**R**eframing' a mind means simply to change its perception and behaviour. This can be done subconsciously to such an extent that subjects have no idea they have been 'reframed' while to any observer changes in behaviour and attitudes are obvious.

Human society is being reframed on a ginormous scale since the start of 2020 and here we have the reason why psychologists rather than doctors have been calling the shots. Ask most people who have succumbed to 'Covid' reframing if they have changed and most will say 'no'; but they *have* and fundamentally. The Cult's long-game has been preparing for these times since way back and crucial to that has been to prepare both population and officialdom mentally and emotionally. To use the mind-control parlance they had to reframe the population with a mentality that would submit to fascism and reframe those in government and law enforcement to impose fascism or at least go along with it. The result has been the fact-deleted mindlessness of 'Wokeness' and officialdom that has either enthusiastically or unquestioningly imposed global tyranny demanded by reframed politicians on behalf of psychopathic and deeply evil cultists. 'Cognitive reframing' identifies and challenges the way someone sees the world in the form of situations, experiences and emotions and then restructures those perceptions to view the same set of circumstances in a different way. This can have

benefits if the attitudes are personally destructive while on the other side it has the potential for individual and collective mind control which the subject has no idea has even happened.

Cognitive therapy was developed in the 1960s by Aaron T. Beck who was born in Rhode Island in 1921 as the son of Jewish immigrants from the Ukraine. He became interested in the techniques as a treatment for depression. Beck's daughter Judith S. Beck is prominent in the same field and they founded the Beck Institute for Cognitive Behavior Therapy in Philadelphia in 1994. Cognitive reframing, however, began to be used worldwide by those with a very dark agenda. The Cult reframes politicians to change their attitudes and actions until they are completely at odds with what they once appeared to stand for. The same has been happening to government administrators at all levels, law enforcement, military and the human population. Cultists love mind control for two main reasons: It allows them to control what people think, do and say to secure agenda advancement and, by definition, it calms their legendary insecurity and fear of the unexpected. I have studied mind control since the time I travelled America in 1996. I may have been talking to next to no one in terms of an audience in those years, but my goodness did I gather a phenomenal amount of information and knowledge about so many things including the techniques of mind control. I have described this in detail in other books going back to *The Biggest Secret* in 1998. I met a very large number of people recovering from MKUltra and its offshoots and successors and I began to see how these same techniques were being used on the population in general. This was never more obvious than since the 'Covid' hoax began.

## **Reframing the enforcers**

I have observed over the last two decades and more the very clear transformation in the dynamic between the police, officialdom and the public. I tracked this in the books as the relationship mutated from one of serving the public to seeing them as almost the enemy and certainly a lower caste. There has always been a class divide

based on income and always been some psychopathic, corrupt, and big-I-am police officers. This was different. Wholesale change was unfolding in the collective dynamic; it was less about money and far more about position and perceived power. An us-and-them was emerging. Noses were lifted skyward by government administration and law enforcement and their attitude to the public they were *supposed* to be serving changed to one of increasing contempt, superiority and control. The transformation was so clear and widespread that it had to be planned. Collective attitudes and dynamics do not change naturally and organically that quickly on that scale. I then came across an organisation in Britain called Common Purpose created in the late 1980s by Julia Middleton who would work in the office of Deputy Prime Minister John Prescott during the long and disastrous premiership of war criminal Tony Blair. When Blair speaks the Cult is speaking and the man should have been in jail a long time ago. Common Purpose proclaims itself to be one of the biggest 'leadership development' organisations in the world while functioning as a *charity* with all the financial benefits which come from that. It hosts 'leadership development' courses and programmes all over the world and claims to have 'brought together' what it calls 'leaders' from more than 100 countries on six continents. The modus operandi of Common Purpose can be compared with the work of the UK government's reframing network that includes the Behavioural Insights Team 'nudge unit' and 'Covid' reframing specialists at SPI-B. WikiLeaks described Common Purpose long ago as 'a hidden virus in our government and schools' which is unknown to the general public: 'It recruits and trains "leaders" to be loyal to the directives of Common Purpose and the EU, instead of to their own departments, which they then undermine or subvert, the NHS [National Health Service] being an example.' This is a vital point to understand the 'Covid' hoax. The NHS, and its equivalent around the world, has been utterly reframed in terms of administrators and much of the medical personnel with the transformation underpinned by recruitment policies. The outcome has been the criminal and psychopathic behaviour of the

NHS over 'Covid' and we have seen the same in every other major country. WikiLeaks said Common Purpose trainees are 'learning to rule without regard to democracy' and to usher in a police state (current events explained). Common Purpose operated like a 'glue' and had members in the NHS, BBC, police, legal profession, church, many of Britain's 7,000 quangos, local councils, the Civil Service, government ministries and Parliament, and controlled many RDA's (Regional Development Agencies). Here we have one answer for how and why British institutions and their like in other countries have changed so negatively in relation to the public. This further explains how and why the beyond-disgraceful reframed BBC has become a propaganda arm of 'Covid' fascism. They are all part of a network pursuing the same goal.

By 2019 Common Purpose was quoting a figure of 85,000 'leaders' that had attended its programmes. These 'students' of all ages are known as Common Purpose 'graduates' and they consist of government, state and local government officials and administrators, police chiefs and officers, and a whole range of others operating within the national, local and global establishment. Cressida Dick, Commissioner of the London Metropolitan Police, is the Common Purpose graduate who was the 'Gold Commander' that oversaw what can only be described as the murder of Brazilian electrician Jean Charles de Menezes in 2005. He was held down by psychopathic police and shot seven times in the head by a psychopathic lunatic after being mistaken for a terrorist when he was just a bloke going about his day. Dick authorised officers to pursue and keep surveillance on de Menezes and ordered that he be stopped from entering the underground train system. Police psychopaths took her at her word clearly. She was 'disciplined' for this outrage by being *promoted* – eventually to the top of the 'Met' police where she has been a disaster. Many Chief Constables controlling the police in different parts of the UK are and have been Common Purpose graduates. I have heard the 'graduate' network described as a sort of Mafia or secret society operating within the fabric of government at all levels pursuing a collective policy



ingrained at Common Purpose training events. Founder Julia Middleton herself has said:

Locally and internationally, Common Purpose graduates will be 'lighting small fires' to create change in their organisations and communities ... The Common Purpose effect is best illustrated by the many stories of small changes brought about by leaders, who themselves have changed.

A Common Purpose mission statement declared:

Common Purpose aims to improve the way society works by expanding the vision, decision-making ability and influence of all kinds of leaders. The organisation runs a variety of educational programmes for leaders of all ages, backgrounds and sectors, in order to provide them with the inspirational, information and opportunities they need to change the world.

Yes, but into what? Since 2020 the answer has become clear.

## **NLP and the Delphi technique**

Common Purpose would seem to be a perfect name or would common programming be better? One of the foundation methods of reaching 'consensus' (group think) is by setting the agenda theme and then encouraging, cajoling or pressuring everyone to agree a 'consensus' in line with the core theme promoted by Common Purpose. The methodology involves the 'Delphi technique', or an adaptation of it, in which opinions are expressed that are summarised by a 'facilitator or change agent' at each stage. Participants are 'encouraged' to modify their views in the light of what others have said. Stage by stage the former individual opinions are merged into group consensus which just happens to be what Common Purpose wants them to believe. A key part of this is to marginalise anyone refusing to concede to group think and turn the group against them to apply pressure to conform. We are seeing this very technique used on the general population to make 'Covid' group-thinkers hostile to those who have seen through the bullshit. People can be reframed by using perception manipulation methods such as Neuro-Linguistic Programming (NLP) in which you change perception with the use of

carefully constructed language. An NLP website described the technique this way:

... A method of influencing brain behaviour (the 'neuro' part of the phrase) through the use of language (the 'linguistic' part) and other types of communication to enable a person to 'recode' the way the brain responds to stimuli (that's the 'programming') and manifest new and better behaviours. Neuro-Linguistic Programming often incorporates hypnosis and self-hypnosis to help achieve the change (or 'programming') that is wanted.

British alternative media operation UKColumn has done very detailed research into Common Purpose over a long period. I quoted co-founder and former naval officer Brian Gerrish in my book *Remember Who You Are*, published in 2011, as saying the following years before current times:

It is interesting that many of the mothers who have had children taken by the State speak of the Social Services people being icily cool, emotionless and, as two ladies said in slightly different words, '... like little robots'. We know that NLP is cumulative, so people can be given small imperceptible doses of NLP in a course here, another in a few months, next year etc. In this way, major changes are accrued in their personality, but the day by day change is almost unnoticeable.

In these and other ways 'graduates' have had their perceptions uniformly reframed and they return to their roles in the institutions of government, law enforcement, legal profession, military, 'education', the UK National Health Service and the whole swathe of the establishment structure to pursue a common agenda preparing for the 'post-industrial', 'post-democratic' society. I say 'preparing' but we are now there. 'Post-industrial' is code for the Great Reset and 'post-democratic' is 'Covid' fascism. UKColumn has spoken to partners of those who have attended Common Purpose 'training'. They have described how personalities and attitudes of 'graduates' changed very noticeably for the worse by the time they had completed the course. They had been 'reframed' and told they are the 'leaders' – the special ones – who know better than the population. There has also been the very demonstrable recruitment of psychopaths and narcissists into government administration at all

levels and law enforcement. If you want psychopathy hire psychopaths and you get a simple cause and effect. If you want administrators, police officers and 'leaders' to perceive the public as lesser beings who don't matter then employ narcissists. These personalities are identified using 'psychometrics' that identifies knowledge, abilities, attitudes and personality traits, mostly through carefully-designed questionnaires and tests. As this policy has passed through the decades we have had power-crazy, power-trippers appointed into law enforcement, security and government administration in preparation for current times and the dynamic between public and law enforcement/officialdom has been transformed. UKColumn's Brian Gerrish said of the narcissistic personality:

Their love of themselves and power automatically means that they will crush others who get in their way. I received a major piece of the puzzle when a friend pointed out that when they made public officials re-apply for their own jobs several years ago they were also required to do psychometric tests. This was undoubtedly the start of the screening process to get 'their' sort of people in post.

How obvious that has been since 2020 although it was clear what was happening long before if people paid attention to the changing public-establishment dynamic.

## **Change agents**

At the centre of events in 'Covid' Britain is the National Health Service (NHS) which has behaved disgracefully in slavishly following the Cult agenda. The NHS management structure is awash with Common Purpose graduates or 'change agents' working to a common cause. Helen Bevan, a Chief of Service Transformation at the NHS Institute for Innovation and Improvement, co-authored a document called 'Towards a million change agents, a review of the social movements literature: implications for large scale change in the NHS'. The document compared a project management approach to that of change and social movements where 'people change

themselves and each other – peer to peer’. Two definitions given for a ‘social movement’ were:

*A group of people who consciously attempt to build a radically new social order; involves people of a broad range of social backgrounds; and deploys politically confrontational and socially disruptive tactics – Cyrus Zirakzadeh 1997*

*Collective challenges, based on common purposes and social solidarities, in sustained interaction with elites, opponents, and authorities – Sidney Tarrow 1994*

Helen Bevan wrote another NHS document in which she defined ‘framing’ as ‘the process by which leaders construct, articulate and put across their message in a powerful and compelling way in order to win people to their cause and call them to action’. I think I could come up with another definition that would be rather more accurate. The National Health Service and institutions of Britain and the wider world have been taken over by reframed ‘change agents’ and that includes everything from the United Nations to national governments, local councils and social services which have been kidnapping children from loving parents on an extraordinary and gathering scale on the road to the end of parenthood altogether. Children from loving homes are stolen and kidnapped by the state and put into the ‘care’ (inversion) of the local authority through council homes, foster parents and forced adoption. At the same time children are allowed to be abused without response while many are under council ‘care’. UKColumn highlighted the Common Purpose connection between South Yorkshire Police and Rotherham council officers in the case of the scandal in that area of the sexual exploitation of children to which the authorities turned not one blind eye, but both:

We were alarmed to discover that the Chief Executive, the Strategic Director of Children and Young People's Services, the Manager for the Local Strategic Partnership, the Community Cohesion Manager, the Cabinet Member for Cohesion, the Chief Constable and his predecessor had all attended Leadership training courses provided by the pseudo-charity Common Purpose.

Once 'change agents' have secured positions of hire and fire within any organisation things start to move very quickly. Personnel are then hired and fired on the basis of whether they will work towards the agenda the change agent represents. If they do they are rapidly promoted even though they may be incompetent. Those more qualified and skilled who are pre-Common Purpose 'old school' see their careers stall and even disappear. This has been happening for decades in every institution of state, police, 'health' and social services and all of them have been transformed as a result in their attitudes to their jobs and the public. Medical professions, including nursing, which were once vocations for the caring now employ many cold, callous and couldn't give a shit personality types. The UKColumn investigation concluded:

By blurring the boundaries between people, professions, public and private sectors, responsibility and accountability, Common Purpose encourages 'graduates' to believe that as new selected leaders, they can work together, outside of the established political and social structures, to achieve a paradigm shift or CHANGE – so called 'Leading Beyond Authority'. In doing so, the allegiance of the individual becomes 'reframed' on CP colleagues and their NETWORK.

## **Reframing the Face-Nappies**

Nowhere has this process been more obvious than in the police where recruitment of psychopaths and development of unquestioning mind-controlled group-thinkers have transformed law enforcement into a politically-correct 'Woke' joke and a travesty of what should be public service. Today they wear their face-nappies like good little gofers and enforce 'Covid' rules which are fascism under another name. Alongside the specifically-recruited psychopaths we have software minds incapable of free thought. Brian Gerrish again:

An example is the policeman who would not get on a bike for a press photo because he had not done the cycling proficiency course. Normal people say this is political correctness gone mad. Nothing could be further from the truth. The policeman has been reframed, and in his reality it is perfect common sense not to get on the bike 'because he hasn't done the cycling course'.

Another example of this is where the police would not rescue a boy from a pond until they had taken advice from above on the 'risk assessment'. A normal person would have arrived, perhaps thought of the risk for a moment, and dived in. To the police now 'reframed', they followed 'normal' procedure.

There are shocking cases of reframed ambulance crews doing the same. Sheer unthinking stupidity of London Face-Nappies headed by Common Purpose graduate Cressida Dick can be seen in their behaviour at a vigil in March, 2021, for a murdered woman, Sarah Everard. A police officer had been charged with the crime. Anyone with a brain would have left the vigil alone in the circumstances. Instead they 'manhandled' women to stop them breaking 'Covid rules' to betray classic reframing. Minds in the thrall of perception control have no capacity for seeing a situation on its merits and acting accordingly. 'Rules is rules' is their only mind-set. My father used to say that rules and regulations are for the guidance of the intelligent and the blind obedience of the idiot. Most of the intelligent, decent, coppers have gone leaving only the other kind and a few old school for whom the job must be a daily nightmare. The combination of psychopaths and rule-book software minds has been clearly on public display in the 'Covid' era with automaton robots in uniform imposing fascistic 'Covid' regulations on the population without any personal initiative or judging situations on their merits. There are thousands of examples around the world, but I'll make my point with the infamous Derbyshire police in the English East Midlands – the ones who think pouring dye into beauty spots and using drones to track people walking in the countryside away from anyone is called 'policing'. To them there are rules decreed by the government which they have to enforce and in their bewildered state a group gathering in a closed space and someone walking alone in the countryside are the same thing. It is beyond idiocy and enters the realm of clinical insanity.

Police officers in Derbyshire said they were 'horrified' – *horrified* – to find 15 to 20 'irresponsible' kids playing a football match at a closed leisure centre 'in breach of coronavirus restrictions'. When they saw the police the kids ran away leaving their belongings behind and the reframed men and women of Derbyshire police were seeking to establish their identities with a view to fining their parents. The most natural thing for youngsters to do – kicking a ball about – is turned into a criminal activity and enforced by the moronic software programs of Derbyshire police. You find the same mentality in every country. These barely conscious 'horrified' officers said they had to take action because 'we need to ensure these rules are being followed' and 'it is of the utmost importance that you ensure your children are following the rules and regulations for Covid-19'. Had any of them done ten seconds of research to see if this parroting of their masters' script could be supported by any evidence? Nope. Reframed people don't think – others think for them and that's the whole idea of reframing. I have seen police officers one after the other repeating without question word for word what officialdom tells them just as I have seen great swathes of the public doing the same. Ask either for 'their' opinion and out spews what they have been told to think by the official narrative. Police and public may seem to be in different groups, but their mentality is the same. Most people do whatever they are told in fear not doing so or because they believe what officialdom tells them; almost the entirety of the police do what they are told for the same reason. Ultimately it's the tiny inner core of the global Cult that's telling both what to do.

So Derbyshire police were 'horrified'. Oh, really? Why did they think those kids were playing football? It was to relieve the psychological consequences of lockdown and being denied human contact with their friends and interaction, touch and discourse vital to human psychological health. Being denied this month after month has dismantled the psyche of many children and young people as depression and suicide have exploded. Were Derbyshire police *horrified by that*? Are you kidding? Reframed people don't have those

mental and emotional processes that can see how the impact on the psychological health of youngsters is far more dangerous than any 'virus' even if you take the mendacious official figures to be true. The reframed are told (programmed) how to act and so they do. The Derbyshire Chief Constable in the first period of lockdown when the black dye and drones nonsense was going on was Peter Goodman. He was the man who severed the connection between his force and the Derbyshire Constabulary *Male Voice* Choir when he decided that it was not inclusive enough to allow women to join. The fact it was a male voice choir making a particular sound produced by male voices seemed to elude a guy who terrifyingly ran policing in Derbyshire. He retired weeks after his force was condemned as disgraceful by former Supreme Court Justice Jonathan Sumption for their behaviour over extreme lockdown impositions. Goodman was replaced by his deputy Rachel Swann who was in charge when her officers were 'horrified'. The police statement over the boys committing the hanging-offence of playing football included the line about the youngsters being 'irresponsible in the times we are all living through' missing the point that the real relevance of the 'times we are all living through' is the imposition of fascism enforced by psychopaths and reframed minds of police officers playing such a vital part in establishing the fascist tyranny that their own children and grandchildren will have to live in their entire lives. As a definition of insanity that is hard to beat although it might be run close by imposing masks on people that can have a serious effect on their health while wearing a face nappy all day themselves. Once again public and police do it for the same reason – the authorities tell them to and who are they to have the self-respect to say no?

## **Workers in uniform**

How reframed do you have to be to arrest a *six-year-old* and take him to court for *picking a flower* while waiting for a bus? Brain dead police and officialdom did just that in North Carolina where criminal proceedings happen regularly for children under nine. Attorney Julie Boyer gave the six-year-old crayons and a colouring book



during the 'flower' hearing while the 'adults' decided his fate. County Chief District Court Judge Jay Corpening asked: 'Should a child that believes in Santa Claus, the Easter Bunny and the tooth fairy be making life-altering decisions?' Well, of course not, but common sense has no meaning when you have a common purpose and a reframed mind. Treating children in this way, and police operating in American schools, is all part of the psychological preparation for children to accept a police state as normal all their adult lives. The same goes for all the cameras and biometric tracking technology in schools. Police training is focused on reframing them as snowflake Wokers and this is happening in the military. Pentagon top brass said that 'training sessions on extremism' were needed for troops who asked why they were so focused on the Capitol Building riot when Black Lives Matter riots were ignored. What's the difference between them some apparently and rightly asked. Actually, there is a difference. Five people died in the Capitol riot, only one through violence, and that was a police officer shooting an unarmed protestor. BLM riots killed at least 25 people and cost billions. Asking the question prompted the psychopaths and reframed minds that run the Pentagon to say that more 'education' (programming) was needed. Troop training is all based on psychological programming to make them fodder for the Cult – 'Military men are just dumb, stupid animals to be used as pawns in foreign policy' as Cult-to-his-DNA former Secretary of State Henry Kissinger famously said. Governments see the police in similar terms and it's time for those among them who can see this to defend the people and stop being enforcers of the Cult agenda upon the people.

The US military, like the country itself, is being targeted for destruction through a long list of Woke impositions. Cult-owned gaga 'President' Biden signed an executive order when he took office to allow taxpayer money to pay for transgender surgery for active military personnel and veterans. Are you a man soldier? No, I'm a LGBTQIA+ with a hint of Skoliosexual and Spectrasexual. Oh, good man. Bad choice of words you bigot. The Pentagon announced in March, 2021, the appointment of the first 'diversity and inclusion

officer' for US Special Forces. Richard Torres-Estrada arrived with the publication of a 'D&I Strategic Plan which will guide the enterprise-wide effort to institutionalize and sustain D&I'. If you think a Special Forces 'Strategic Plan' should have something to do with defending America you haven't been paying attention. Defending Woke is now the military's new role. Torres-Estrada has posted images comparing Donald Trump with Adolf Hitler and we can expect no bias from him as a representative of the supposedly non-political Pentagon. Cable news host Tucker Carlson said: 'The Pentagon is now the Yale faculty lounge but with cruise missiles.' Meanwhile Secretary of Defense Lloyd Austin, a board member of weapons-maker Raytheon with stock and compensation interests in October, 2020, worth \$1.4 million, said he was purging the military of the 'enemy within' – anyone who isn't Woke and supports Donald Trump. Austin refers to his targets as 'racist extremists' while in true Woke fashion being himself a racist extremist. Pentagon documents pledge to 'eradicate, eliminate and conquer all forms of racism, sexism and homophobia'. The definitions of these are decided by 'diversity and inclusion committees' peopled by those who see racism, sexism and homophobia in every situation and opinion. Woke (the Cult) is dismantling the US military and purging testosterone as China expands its military and gives its troops 'masculinity training'. How do we think that is going to end when this is all Cult coordinated? The US military, like the British military, is controlled by Woke and spineless top brass who just go along with it out of personal career interests.

### **'Woke' means fast asleep**

Mind control and perception manipulation techniques used on individuals to create group-think have been unleashed on the global population in general. As a result many have no capacity to see the obvious fascist agenda being installed all around them or what 'Covid' is really all about. Their brains are firewalled like a computer system not to process certain concepts, thoughts and realisations that are bad for the Cult. The young are most targeted as the adults they

will be when the whole fascist global state is planned to be fully implemented. They need to be prepared for total compliance to eliminate all pushback from entire generations. The Cult has been pouring billions into taking complete control of 'education' from schools to universities via its operatives and corporations and not least Bill Gates as always. The plan has been to transform 'education' institutions into programming centres for the mentality of 'Woke'. James McConnell, professor of psychology at the University of Michigan, wrote in *Psychology Today* in 1970:

The day has come when we can combine sensory deprivation with drugs, hypnosis, and astute manipulation of reward and punishment, to gain almost absolute control over an individual's behaviour. It should then be possible to achieve a very rapid and highly effective type of brainwashing that would allow us to make dramatic changes in a person's behaviour and personality ...

... We should reshape society so that we all would be trained from birth to want to do what society wants us to do. We have the techniques to do it... no-one owns his own personality you acquired, and there's no reason to believe you should have the right to refuse to acquire a new personality if your old one is anti-social.

This was the potential for mass brainwashing in 1970 and the mentality there displayed captures the arrogant psychopathy that drives it forward. I emphasise that not all young people have succumbed to Woke programming and those that haven't are incredibly impressive people given that today's young are the most perceptually-targeted generations in history with all the technology now involved. Vast swathes of the young generations, however, have fallen into the spell – and that's what it is – of Woke. The Woke mentality and perceptual program is founded on *inversion* and you will appreciate later why that is so significant. Everything with Woke is inverted and the opposite of what it is claimed to be. Woke was a term used in African-American culture from the 1900s and referred to an awareness of social and racial justice. This is not the meaning of the modern version or 'New Woke' as I call it in *The Answer*. Oh, no, Woke today means something very different no matter how much Wokers may seek to hide that and insist Old Woke and New

Woke are the same. See if you find any 'awareness of social justice' here in the modern variety:

- Woke demands 'inclusivity' while excluding anyone with a different opinion and calls for mass censorship to silence other views.
- Woke claims to stand against oppression when imposing oppression is the foundation of all that it does. It is the driver of political correctness which is nothing more than a Cult invention to manipulate the population to silence itself.
- Woke believes itself to be 'liberal' while pursuing a global society that can only be described as fascist (see 'anti-fascist' fascist Antifa).
- Woke calls for 'social justice' while spreading injustice wherever it goes against the common 'enemy' which can be easily identified as a differing view.
- Woke is supposed to be a metaphor for 'awake' when it is solid-gold asleep and deep in a Cult-induced coma that meets the criteria for 'off with the fairies'.

I state these points as obvious facts if people only care to look. I don't do this with a sense of condemnation. We need to appreciate that the onslaught of perceptual programming on the young has been incessant and merciless. I can understand why so many have been reframed, or, given their youth, framed from the start to see the world as the Cult demands. The Cult has had access to their minds day after day in its 'education' system for their entire formative years. Perception is formed from information received and the Cult-created system is a life-long download of information delivered to elicit a particular perception, thus behaviour. The more this has expanded into still new extremes in recent decades and ever-increasing censorship has deleted other opinions and information why wouldn't that lead to a perceptual reframing on a mass scale? I

have described already cradle-to-grave programming and in more recent times the targeting of young minds from birth to adulthood has entered the stratosphere. This has taken the form of skewing what is 'taught' to fit the Cult agenda and the omnipresent techniques of group-think to isolate non-believers and pressure them into line. There has always been a tendency to follow the herd, but we really are in a new world now in relation to that. We have parents who can see the 'Covid' hoax told by their children not to stop them wearing masks at school, being 'Covid' tested or having the 'vaccine' in fear of the peer-pressure consequences of being different. What is 'peer-pressure' if not pressure to conform to group-think? Renegade Minds never group-think and always retain a set of perceptions that are unique to them. Group-think is always underpinned by consequences for not group-thinking. Abuse now aimed at those refusing DNA-manipulating 'Covid vaccines' are a potent example of this. The biggest pressure to conform comes from the very group which is itself being manipulated. 'I am programmed to be part of a hive mind and so you must be.'

Woke control structures in 'education' now apply to every mainstream organisation. Those at the top of the 'education' hierarchy (the Cult) decide the policy. This is imposed on governments through the Cult network; governments impose it on schools, colleges and universities; their leadership impose the policy on teachers and academics and they impose it on children and students. At any level where there is resistance, perhaps from a teacher or university lecturer, they are targeted by the authorities and often fired. Students themselves regularly demand the dismissal of academics (increasingly few) at odds with the narrative that the students have been programmed to believe in. It is quite a thought that students who are being targeted by the Cult become so consumed by programmed group-think that they launch protests and demand the removal of those who are trying to push back against those targeting the students. Such is the scale of perceptual inversion. We see this with 'Covid' programming as the Cult imposes the rules via psycho-psychologists and governments on

shops, transport companies and businesses which impose them on their staff who impose them on their customers who pressure Pushbackers to conform to the will of the Cult which is in the process of destroying them and their families. Scan all aspects of society and you will see the same sequence every time.

### **Fact free Woke and hijacking the 'left'**

There is no more potent example of this than 'Woke', a mentality only made possible by the deletion of factual evidence by an 'education' system seeking to produce an ever more uniform society. Why would you bother with facts when you don't know any? Deletion of credible history both in volume and type is highly relevant. Orwell said: 'Who controls the past controls the future: who controls the present controls the past.' They who control the perception of the past control the perception of the future and they who control the present control the perception of the past through the writing and deleting of history. Why would you oppose the imposition of Marxism in the name of Wokeism when you don't know that Marxism cost at least 100 million lives in the 20th century alone? Watch videos and read reports in which Woker generations are asked basic historical questions – it's mind-blowing. A survey of 2,000 people found that six percent of millennials (born approximately early 1980s to early 2000s) believed the Second World War (1939-1945) broke out with the assassination of President Kennedy (in 1963) and one in ten thought Margaret Thatcher was British Prime Minister at the time. She was in office between 1979 and 1990. We are in a post-fact society. Provable facts are no defence against the fascism of political correctness or Silicon Valley censorship. Facts don't matter anymore as we have witnessed with the 'Covid' hoax. Sacrificing uniqueness to the Woke group-think religion is all you are required to do and that means thinking for yourself is the biggest Woke no, no. All religions are an expression of group-think and censorship and Woke is just another religion with an orthodoxy defended by group-think and censorship. Burned at

the stake becomes burned on Twitter which leads back eventually to burned at the stake as Woke humanity regresses to ages past.

The biggest Woke inversion of all is its creators and funders. I grew up in a traditional left of centre political household on a council estate in Leicester in the 1950s and 60s – you know, the left that challenged the power of wealth-hoarding elites and threats to freedom of speech and opinion. In those days students went on marches defending freedom of speech while today's Wokers march for its deletion. What on earth could have happened? Those very elites (collectively the Cult) that we opposed in my youth and early life have funded into existence the antithesis of that former left and hijacked the 'brand' while inverting everything it ever stood for. We have a mentality that calls itself 'liberal' and 'progressive' while acting like fascists. Cult billionaires and their corporations have funded themselves into control of 'education' to ensure that Woke programming is unceasing throughout the formative years of children and young people and that non-Wokers are isolated (that word again) whether they be students, teachers or college professors. The Cult has funded into existence the now colossal global network of Woke organisations that have spawned and promoted all the 'causes' on the Cult wish-list for global transformation and turned Wokers into demanders of them. Does anyone really think it's a coincidence that the Cult agenda for humanity is a carbon (sorry) copy of the societal transformations desired by Woke?? These are only some of them:

**Political correctness:** The means by which the Cult deletes all public debates that it knows it cannot win if we had the free-flow of information and evidence.

**Human-caused 'climate change':** The means by which the Cult seeks to transform society into a globally-controlled dictatorship imposing its will over the fine detail of everyone's lives 'to save the planet' which doesn't actually need saving.

**Transgender obsession:** Preparing collective perception to accept the 'new human' which would not have genders because it would be created technologically and not through procreation. I'll have much more on this in Human 2.0.

**Race obsession:** The means by which the Cult seeks to divide and rule the population by triggering racial division through the perception that society is more racist than ever when the opposite is the case. Is it perfect in that regard? No. But to compare today with the racism of apartheid and segregation brought to an end by the civil rights movement in the 1960s is to insult the memory of that movement and inspirations like Martin Luther King. Why is the 'anti-racism' industry (which it is) so dominated by privileged white people?

**White supremacy:** This is a label used by privileged white people to demonise poor and deprived white people pushing back on tyranny to marginalise and destroy them. White people are being especially targeted as the dominant race by number within Western society which the Cult seeks to transform in its image. If you want to change a society you must weaken and undermine its biggest group and once you have done that by using the other groups you next turn on them to do the same ... 'Then they came for the Jews and I was not a Jew so I did nothing.'

**Mass migration:** The mass movement of people from the Middle East, Africa and Asia into Europe, from the south into the United States and from Asia into Australia are another way the Cult seeks to dilute the racial, cultural and political influence of white people on Western society. White people ask why their governments appear to be working against them while being politically and culturally biased towards incoming cultures. Well, here's your answer. In the same way sexually 'straight' people, men and women, ask why the



authorities are biased against them in favour of other sexualities. The answer is the same – that's the way the Cult wants it to be for very sinister motives.

These are all central parts of the Cult agenda and central parts of the Woke agenda and Woke was created and continues to be funded to an immense degree by Cult billionaires and corporations. If anyone begins to say 'coincidence' the syllables should stick in their throat.

### **Billionaire 'social justice warriors'**

Joe Biden is a 100 percent-owned asset of the Cult and the Wokers' man in the White House whenever he can remember his name and for however long he lasts with his rapidly diminishing cognitive function. Even walking up the steps of an aircraft without falling on his arse would appear to be a challenge. He's not an empty-shell puppet or anything. From the minute Biden took office (or the Cult did) he began his executive orders promoting the Woke wish-list. You will see the Woke agenda imposed ever more severely because it's really the *Cult* agenda. Woke organisations and activist networks spawned by the Cult are funded to the extreme so long as they promote what the Cult wants to happen. Woke is funded to promote 'social justice' by billionaires who become billionaires by destroying social justice. The social justice mantra is only a cover for dismantling social justice and funded by billionaires that couldn't give a damn about social justice. Everything makes sense when you see that. One of Woke's premier funders is Cult billionaire financier George Soros who said: 'I am basically there to make money, I cannot and do not look at the social consequences of what I do.' This is the same Soros who has given more than \$32 billion to his Open Society Foundations global Woke network and funded Black Lives Matter, mass immigration into Europe and the United States, transgender activism, climate change activism, political correctness and groups targeting 'white supremacy' in the form of privileged white thugs that dominate Antifa. What a scam it all is and when

you are dealing with the unquestioning fact-free zone of Woke scamming them is child's play. All you need to pull it off in all these organisations are a few in-the-know agents of the Cult and an army of naïve, reframed, uninformed, narcissistic, know-nothings convinced of their own self-righteousness, self-purity and virtue.

Soros and fellow billionaires and billionaire corporations have poured hundreds of millions into Black Lives Matter and connected groups and promoted them to a global audience. None of this is motivated by caring about black people. These are the billionaires that have controlled and exploited a system that leaves millions of black people in abject poverty and deprivation which they do absolutely nothing to address. The same Cult networks funding BLM were behind the *slave trade*! Black Lives Matter hijacked a phrase that few would challenge and they have turned this laudable concept into a political weapon to divide society. You know that BLM is a fraud when it claims that *All Lives Matter*, the most inclusive statement of all, is 'racist'. BLM and its Cult masters don't want to end racism. To them it's a means to an end to control all of humanity never mind the colour, creed, culture or background. What has destroying the nuclear family got to do with ending racism? Nothing – but that is one of the goals of BLM and also happens to be a goal of the Cult as I have been exposing in my books for decades. Stealing children from loving parents and giving schools ever more power to override parents is part of that same agenda. BLM is a Marxist organisation and why would that not be the case when the Cult created Marxism *and* BLM? Patrisse Cullors, a BLM co-founder, said in a 2015 video that she and her fellow organisers, including co-founder Alicia Garza, are 'trained Marxists'. The lady known after marriage as Patrisse Khan-Cullors bought a \$1.4 million home in 2021 in one of the whitest areas of California with a black population of just 1.6 per cent and has so far bought *four* high-end homes for a total of \$3.2 million. How very Marxist. There must be a bit of spare in the BLM coffers, however, when Cult corporations and billionaires have handed over the best part of \$100 million. Many black people can see that Black Lives Matter is not

working for them, but against them, and this is still more confirmation. Black journalist Jason Whitlock, who had his account suspended by Twitter for simply linking to the story about the 'Marxist's' home buying spree, said that BLM leaders are 'making millions of dollars off the backs of these dead black men who they wouldn't spit on if they were on fire and alive'.

## **Black Lies Matter**

Cult assets and agencies came together to promote BLM in the wake of the death of career criminal George Floyd who had been jailed a number of times including for forcing his way into the home of a black woman with others in a raid in which a gun was pointed at her stomach. Floyd was filmed being held in a Minneapolis street in 2020 with the knee of a police officer on his neck and he subsequently died. It was an appalling thing for the officer to do, but the same technique has been used by police on peaceful protestors of lockdown without any outcry from the Woke brigade. As unquestioning supporters of the Cult agenda Wokers have supported lockdown and all the 'Covid' claptrap while attacking anyone standing up to the tyranny imposed in its name. Court documents would later include details of an autopsy on Floyd by County Medical Examiner Dr Andrew Baker who concluded that Floyd had taken a fatal level of the drug fentanyl. None of this mattered to fact-free, question-free, Woke. Floyd's death was followed by worldwide protests against police brutality amid calls to defund the police. Throwing babies out with the bathwater is a Woke speciality. In the wake of the murder of British woman Sarah Everard a Green Party member of the House of Lords, Baroness Jones of Moulscroomb (Nincompoopia would have been better), called for a 6pm curfew for all men. This would be in breach of the Geneva Conventions on war crimes which ban collective punishment, but that would never have crossed the black and white Woke mind of Baroness Nincompoopia who would have been far too convinced of her own self-righteousness to compute such details. Many American cities did defund the police in the face of Floyd riots

and after \$15 million was deleted from the police budget in Washington DC under useless Woke mayor Muriel Bowser car-jacking alone rose by 300 percent and within six months the US capital recorded its highest murder rate in 15 years. The same happened in Chicago and other cities in line with the Cult/Soros plan to bring fear to streets and neighbourhoods by reducing the police, releasing violent criminals and not prosecuting crime. This is the mob-rule agenda that I have warned in the books was coming for so long. Shootings in the area of Minneapolis where Floyd was arrested increased by 2,500 percent compared with the year before. Defunding the police over George Floyd has led to a big increase in dead people with many of them black. Police protection for politicians making these decisions stayed the same or increased as you would expect from professional hypocrites. The Cult doesn't actually want to abolish the police. It wants to abolish local control over the police and hand it to federal government as the psychopaths advance the Hunger Games Society. Many George Floyd protests turned into violent riots with black stores and businesses destroyed by fire and looting across America fuelled by Black Lives Matter. Woke doesn't do irony. If you want civil rights you must loot the liquor store and the supermarket and make off with a smart TV. It's the only way.

### **It's not a race war – it's a class war**

Black people are patronised by privileged blacks and whites alike and told they are victims of white supremacy. I find it extraordinary to watch privileged blacks supporting the very system and bloodline networks behind the slave trade and parroting the same Cult-serving manipulative crap of their privileged white, often billionaire, associates. It is indeed not a race war but a class war and colour is just a diversion. Black Senator Cory Booker and black Congresswoman Maxine Waters, more residents of Nincompoopia, personify this. Once you tell people they are victims of someone else you devalue both their own responsibility for their plight and the power they have to impact on their reality and experience. Instead

we have: 'You are only in your situation because of whitey – turn on them and everything will change.' It won't change. Nothing changes in our lives unless *we* change it. Crucial to that is never seeing yourself as a victim and always as the creator of your reality. Life is a simple sequence of choice and consequence. Make different choices and you create different consequences. *You* have to make those choices – not Black Lives Matter, the Woke Mafia and anyone else that seeks to dictate your life. Who are they these Wokers, an emotional and psychological road traffic accident, to tell you what to do? Personal empowerment is the last thing the Cult and its Black Lives Matter want black people or anyone else to have. They claim to be defending the underdog while *creating* and perpetuating the underdog. The Cult's worst nightmare is human unity and if they are going to keep blacks, whites and every other race under economic servitude and control then the focus must be diverted from what they have in common to what they can be manipulated to believe divides them. Blacks have to be told that their poverty and plight is the fault of the white bloke living on the street in the same poverty and with the same plight they are experiencing. The difference is that your plight black people is due to him, a white supremacist with 'white privilege' living on the street. Don't unite as one human family against your mutual oppressors and suppressors – fight the oppressor with the white face who is as financially deprived as you are. The Cult knows that as its 'Covid' agenda moves into still new levels of extremism people are going to respond and it has been spreading the seeds of disunity everywhere to stop a united response to the evil that targets *all of us*.

Racist attacks on 'whiteness' are getting ever more outrageous and especially through the American Democratic Party which has an appalling history for anti-black racism. Barack Obama, Joe Biden, Hillary Clinton and Nancy Pelosi all eulogised about Senator Robert Byrd at his funeral in 2010 after a nearly 60-year career in Congress. Byrd was a brutal Ku Klux Klan racist and a violent abuser of Cathy O'Brien in MKUltra. He said he would never fight in the military 'with a negro by my side' and 'rather I should die a thousand times,

and see Old Glory trampled in the dirt never to rise again, than to see this beloved land of ours become degraded by race mongrels, a throwback to the blackest specimen from the wilds'. Biden called Byrd a 'very close friend and mentor'. These 'Woke' hypocrites are not anti-racist they are anti-poor and anti-people not of their perceived class. Here is an illustration of the scale of anti-white racism to which we have now descended. Seriously Woke and moronic *New York Times* contributor Damon Young described whiteness as a 'virus' that 'like other viruses will not die until there are no bodies left for it to infect'. He went on: '... the only way to stop it is to locate it, isolate it, extract it, and kill it.' Young can say that as a black man with no consequences when a white man saying the same in reverse would be facing a jail sentence. *That's* racism. We had super-Woke numbskull senators Tammy Duckworth and Mazie Hirono saying they would object to future Biden Cabinet appointments if he did not nominate more Asian Americans and Pacific Islanders. Never mind the ability of the candidate what do they look like? Duckworth said: 'I will vote for racial minorities and I will vote for LGBTQ, but anyone else I'm not voting for.' Appointing people on the grounds of race is illegal, but that was not a problem for this ludicrous pair. They were on-message and that's a free pass in any situation.

## **Critical race racism**

White children are told at school they are intrinsically racist as they are taught the divisive 'critical race theory'. This claims that the law and legal institutions are inherently racist and that race is a socially constructed concept used by white people to further their economic and political interests at the expense of people of colour. White is a 'virus' as we've seen. Racial inequality results from 'social, economic, and legal differences that white people create between races to maintain white interests which leads to poverty and criminality in minority communities'. I must tell that to the white guy sleeping on the street. The principal of East Side Community School in New York sent white parents a manifesto that called on

them to become 'white traitors' and advocate for full 'white abolition'. These people are teaching your kids when they urgently need a psychiatrist. The 'school' included a chart with 'eight white identities' that ranged from 'white supremacist' to 'white abolition' and defined the behaviour white people must follow to end 'the regime of whiteness'. Woke blacks and their privileged white associates are acting exactly like the slave owners of old and Ku Klux Klan racists like Robert Byrd. They are too full of their own self-purity to see that, but it's true. Racism is not a body type; it's a state of mind that can manifest through any colour, creed or culture.

Another racial fraud is '*equity*'. Not equality of treatment and opportunity – equity. It's a term spun as equality when it means something very different. Equality in its true sense is a raising up while '*equity*' is a race to the bottom. Everyone in the same level of poverty is '*equity*'. Keep everyone down – that's equity. The Cult doesn't want anyone in the human family to be empowered and BLM leaders, like all these 'anti-racist' organisations, continue their privileged, pampered existence by perpetuating the perception of gathering racism. When is the last time you heard an 'anti-racist' or 'anti-Semitism' organisation say that acts of racism and discrimination have *fallen*? It's not in the interests of their fundraising and power to influence and the same goes for the professional soccer anti-racism operation, Kick It Out. Two things confirmed that the Black Lives Matter riots in the summer of 2020 were Cult creations. One was that while anti-lockdown protests were condemned in this same period for 'transmitting 'Covid' the authorities supported mass gatherings of Black Lives Matter supporters. I even saw self-deluding people claiming to be doctors say the two types of protest were not the same. No – the non-existent 'Covid' was in favour of lockdowns and attacked those that protested against them while 'Covid' supported Black Lives Matter and kept well away from its protests. The whole thing was a joke and as lockdown protestors were arrested, often brutally, by reframed Face-Nappies we had the grotesque sight of police officers taking the knee to Black Lives Matter, a Cult-funded Marxist

organisation that supports violent riots and wants to destroy the nuclear family and white people.

### **He's not white? Shucks!**

Woke obsession with race was on display again when ten people were shot dead in Boulder, Colorado, in March, 2021. Cult-owned Woke TV channels like CNN said the shooter appeared to be a white man and Wokers were on Twitter condemning 'violent white men' with the usual mantras. Then the shooter's name was released as Ahmad Al Aliwi Alissa, an anti-Trump Arab-American, and the sigh of disappointment could be heard five miles away. Never mind that ten people were dead and what that meant for their families. Race baiting was all that mattered to these sick Cult-serving people like Barack Obama who exploited the deaths to further divide America on racial grounds which is his job for the Cult. This is the man that 'racist' white Americans made the first black president of the United States and then gave him a second term. Not-very-bright Obama has become filthy rich on the back of that and today appears to have a big influence on the Biden administration. Even so he's still a downtrodden black man and a victim of white supremacy. This disingenuous fraud reveals the contempt he has for black people when he puts on a Deep South Alabama accent whenever he talks to them, no, *at* them.

Another BLM red flag was how the now fully-Woke (fully-Cult) and fully-virtue-signalled professional soccer authorities had their teams taking the knee before every match in support of Marxist Black Lives Matter. Soccer authorities and clubs displayed 'Black Lives Matter' on the players' shirts and flashed the name on electronic billboards around the pitch. Any fans that condemned what is a Freemasonic taking-the-knee ritual were widely condemned as you would expect from the Woke virtue-signallers of professional sport and the now fully-Woke media. We have reverse racism in which you are banned from criticising any race or culture except for white people for whom anything goes – say what you like, no problem. What has this got to do with racial harmony and



equality? We've had black supremacists from Black Lives Matter telling white people to fall to their knees in the street and apologise for their white supremacy. Black supremacists acting like white supremacist slave owners of the past couldn't breach their self-obsessed, race-obsessed sense of self-purity. Joe Biden appointed a race-obsessed black supremacist Kristen Clarke to head the Justice Department Civil Rights Division. Clarke claimed that blacks are endowed with 'greater mental, physical and spiritual abilities' than whites. If anyone reversed that statement they would be vilified. Clarke is on-message so no problem. She's never seen a black-white situation in which the black figure is anything but a virtuous victim and she heads the Civil Rights Division which should treat everyone the same or it isn't civil rights. Another perception of the Renegade Mind: If something or someone is part of the Cult agenda they will be supported by Woke governments and media no matter what. If they're not, they will be condemned and censored. It really is that simple and so racist Clarke prospers despite (make that because of) her racism.

## **The end of culture**

Biden's administration is full of such racial, cultural and economic bias as the Cult requires the human family to be divided into warring factions. We are now seeing racially-segregated graduations and everything, but everything, is defined through the lens of perceived 'racism'. We have 'racist' mathematics, 'racist' food and even 'racist' *plants*. World famous Kew Gardens in London said it was changing labels on plants and flowers to tell its pre-'Covid' more than two million visitors a year how racist they are. Kew director Richard Deverell said this was part of an effort to 'move quickly to decolonise collections' after they were approached by one Ajay Chhabra 'an actor with an insight into how sugar cane was linked to slavery'. They are *plants* you idiots. 'Decolonisation' in the Woke manual really means colonisation of society with its mentality and by extension colonisation by the Cult. We are witnessing a new Chinese-style 'Cultural Revolution' so essential to the success of all

Marxist takeovers. Our cultural past and traditions have to be swept away to allow a new culture to be built-back-better. Woke targeting of long-standing Western cultural pillars including historical monuments and cancelling of historical figures is what happened in the Mao revolution in China which 'purged remnants of capitalist and traditional elements from Chinese society' and installed Maoism as the dominant ideology'. For China see the Western world today and for 'dominant ideology' see Woke. Better still see Marxism or Maoism. The 'Covid' hoax has specifically sought to destroy the arts and all elements of Western culture from people meeting in a pub or restaurant to closing theatres, music venues, sports stadiums, places of worship and even banning *singing*. Destruction of Western society is also why criticism of any religion is banned except for Christianity which again is the dominant religion as white is the numerically-dominant race. Christianity may be fading rapidly, but its history and traditions are weaved through the fabric of Western society. Delete the pillars and other structures will follow until the whole thing collapses. I am not a Christian defending that religion when I say that. I have no religion. It's just a fact. To this end Christianity has itself been turned Woke to usher its own downfall and its ranks are awash with 'change agents' – knowing and unknowing – at every level including Pope Francis (*definitely* knowing) and the clueless Archbishop of Canterbury Justin Welby (possibly not, but who can be sure?). Woke seeks to coordinate attacks on Western culture, traditions, and ways of life through 'intersectionality' defined as 'the complex, cumulative way in which the effects of multiple forms of discrimination (such as racism, sexism, and classism) combine, overlap, or intersect especially in the experiences of marginalised individuals or groups'. Wade through the Orwellian Woke-speak and this means coordinating disparate groups in a common cause to overthrow freedom and liberal values.

The entire structure of public institutions has been infested with Woke – government at all levels, political parties, police, military, schools, universities, advertising, media and trade unions. This abomination has been achieved through the Cult web by appointing

Wokers to positions of power and battering non-Wokers into line through intimidation, isolation and threats to their job. Many have been fired in the wake of the empathy-deleted, vicious hostility of 'social justice' Wokers and the desire of gutless, spineless employers to virtue-signal their Wokeness. Corporations are filled with Wokers today, most notably those in Silicon Valley. Ironically at the top they are not Woke at all. They are only exploiting the mentality their Cult masters have created and funded to censor and enslave while the Wokers cheer them on until it's their turn. Thus the Woke 'liberal left' is an inversion of the traditional liberal left. Campaigning for justice on the grounds of power and wealth distribution has been replaced by campaigning for identity politics. The genuine traditional left would never have taken money from today's billionaire abusers of fairness and justice and nor would the billionaires have wanted to fund that genuine left. It would not have been in their interests to do so. The division of opinion in those days was between the haves and have nots. This all changed with Cult manipulated and funded identity politics. The division of opinion today is between Wokers and non-Wokers and not income brackets. Cult corporations and their billionaires may have taken wealth disparity to cataclysmic levels of injustice, but as long as they speak the language of Woke, hand out the dosh to the Woke network and censor the enemy they are 'one of us'. Billionaires who don't give a damn about injustice are laughing at them till their bellies hurt. Wokers are not even close to self-aware enough to see that. The transformed 'left' dynamic means that Wokers who drone on about 'social justice' are funded by billionaires that have destroyed social justice the world over. It's *why* they are billionaires.

## **The climate con**

Nothing encapsulates what I have said more comprehensively than the hoax of human-caused global warming. I have detailed in my books over the years how Cult operatives and organisations were the pump-primers from the start of the climate con. A purpose-built vehicle for this is the Club of Rome established by the Cult in 1968

with the Rockefellers and Rothschilds centrally involved all along. Their gofer frontman Maurice Strong, a Canadian oil millionaire, hosted the Earth Summit in Rio de Janeiro, Brazil, in 1992 where the global 'green movement' really expanded in earnest under the guiding hand of the Cult. The Earth Summit established Agenda 21 through the Cult-created-and-owned United Nations to use the illusion of human-caused climate change to justify the transformation of global society to save the world from climate disaster. It is a No-Problem-Reaction-Solution sold through governments, media, schools and universities as whole generations have been terrified into believing that the world was going to end in their lifetimes unless what old people had inflicted upon them was stopped by a complete restructuring of how everything is done. Chill, kids, it's all a hoax. Such restructuring is precisely what the Cult agenda demands (purely by coincidence of course). Today this has been given the codename of the Great Reset which is only an updated term for Agenda 21 and its associated Agenda 2030. The latter, too, is administered through the UN and was voted into being by the General Assembly in 2015. Both 21 and 2030 seek centralised control of all resources and food right down to the raindrops falling on your own land. These are some of the demands of Agenda 21 established in 1992. See if you recognise this society emerging today:

- End national sovereignty
- State planning and management of all land resources, ecosystems, deserts, forests, mountains, oceans and fresh water; agriculture; rural development; biotechnology; and ensuring 'equity'
- The state to 'define the role' of business and financial resources
- Abolition of private property
- 'Restructuring' the family unit (see BLM)
- Children raised by the state
- People told what their job will be
- Major restrictions on movement
- Creation of 'human settlement zones'

- Mass resettlement as people are forced to vacate land where they live
- Dumbing down education
- Mass global depopulation in pursuit of all the above

The United Nations was created as a Trojan horse for world government. With the climate con of critical importance to promoting that outcome you would expect the UN to be involved. Oh, it's involved all right. The UN is promoting Agenda 21 and Agenda 2030 justified by 'climate change' while also driving the climate hoax through its Intergovernmental Panel on Climate Change (IPCC), one of the world's most corrupt organisations. The IPCC has been lying ferociously and constantly since the day it opened its doors with the global media hanging unquestioningly on its every mendacious word. The Green movement is entirely Woke and has long lost its original environmental focus since it was co-opted by the Cult. An obsession with 'global warming' has deleted its values and scrambled its head. I experienced a small example of what I mean on a beautiful country walk that I have enjoyed several times a week for many years. The path merged into the fields and forests and you felt at one with the natural world. Then a 'Green' organisation, the Hampshire and Isle of Wight Wildlife Trust, took over part of the land and proceeded to cut down a large number of trees, including mature ones, to install a horrible big, bright steel 'this-is-ours-stay-out' fence that destroyed the whole atmosphere of this beautiful place. No one with a feel for nature would do that. Day after day I walked to the sound of chainsaws and a magnificent mature weeping willow tree that I so admired was cut down at the base of the trunk. When I challenged a Woke young girl in a green shirt (of course) about this vandalism she replied: 'It's a weeping willow – it will grow back.' This is what people are paying for when they donate to the Hampshire and Isle of Wight Wildlife Trust and many other 'green' organisations today. It is not the environmental movement that I knew and instead has become a support-system – as with Extinction Rebellion – for a very dark agenda.

## **Private jets for climate justice**

The Cult-owned, Gates-funded, World Economic Forum and its founder Klaus Schwab were behind the emergence of Greta Thunberg to harness the young behind the climate agenda and she was invited to speak to the world at ... the UN. Schwab published a book, *Covid-19: The Great Reset* in 2020 in which he used the 'Covid' hoax and the climate hoax to lay out a new society straight out of Agenda 21 and Agenda 2030. Bill Gates followed in early 2021 when he took time out from destroying the world to produce a book in his name about the way to save it. Gates flies across the world in private jets and admitted that 'I probably have one of the highest greenhouse gas footprints of anyone on the planet ... my personal flying alone is gigantic.' He has also bid for the planet's biggest private jet operator. Other climate change saviours who fly in private jets include John Kerry, the US Special Presidential Envoy for Climate, and actor Leonardo DiCaprio, a 'UN Messenger of Peace with special focus on climate change'. These people are so full of bullshit they could corner the market in manure. We mustn't be sceptical, though, because the Gates book, *How to Avoid a Climate Disaster: The Solutions We Have and the Breakthroughs We Need*, is a genuine attempt to protect the world and not an obvious pile of excrement attributed to a mega-psychopath aimed at selling his masters' plans for humanity. The Gates book and the other shite-pile by Klaus Schwab could have been written by the same person and may well have been. Both use 'climate change' and 'Covid' as the excuses for their new society and by coincidence the Cult's World Economic Forum and Bill and Melinda Gates Foundation promote the climate hoax and hosted Event 201 which pre-empted with a 'simulation' the very 'coronavirus' hoax that would be simulated for real on humanity within weeks. The British 'royal' family is promoting the 'Reset' as you would expect through Prince 'climate change caused the war in Syria' Charles and his hapless son Prince William who said that we must 'reset our relationship with nature and our trajectory as a species' to avoid a climate disaster. Amazing how many promoters of the 'Covid' and 'climate change' control

systems are connected to Gates and the World Economic Forum. A 'study' in early 2021 claimed that carbon dioxide emissions must fall by the equivalent of a global lockdown roughly every two years for the next decade to save the planet. The 'study' appeared in the same period that the Schwab mob claimed in a video that lockdowns destroying the lives of billions are good because they make the earth 'quieter' with less 'ambient noise'. They took down the video amid a public backlash for such arrogant, empathy-deleted stupidity You see, however, where they are going with this. Corinne Le Quéré, a professor at the Tyndall Centre for Climate Change Research, University of East Anglia, was lead author of the climate lockdown study, and she writes for ... the World Economic Forum. Gates calls in 'his' book for changing 'every aspect of the economy' (long-time Cult agenda) and for humans to eat synthetic 'meat' (predicted in my books) while cows and other farm animals are eliminated. Australian TV host and commentator Alan Jones described what carbon emission targets would mean for farm animals in Australia alone if emissions were reduced as demanded by 35 percent by 2030 and zero by 2050:

Well, let's take agriculture, the total emissions from agriculture are about 75 million tonnes of carbon dioxide, equivalent. Now reduce that by 35 percent and you have to come down to 50 million tonnes, I've done the maths. So if you take for example 1.5 million cows, you're going to have to reduce the herd by 525,000 [by] 2030, nine years, that's 58,000 cows a year. The beef herd's 30 million, reduce that by 35 percent, that's 10.5 million, which means 1.2 million cattle have to go every year between now and 2030. This is insanity!

There are 75 million sheep. Reduce that by 35 percent, that's 26 million sheep, that's almost 3 million a year. So under the Paris Agreement over 30 million beasts. dairy cows, cattle, pigs and sheep would go. More than 8,000 every minute of every hour for the next decade, do these people know what they're talking about?

Clearly they don't at the level of campaigners, politicians and administrators. The Cult *does* know; that's the outcome it wants. We are faced with not just a war on humanity. Animals and the natural world are being targeted and I have been saying since the 'Covid' hoax began that the plan eventually was to claim that the 'deadly virus' is able to jump from animals, including farm animals and

domestic pets, to humans. Just before this book went into production came this story: 'Russia registers world's first Covid-19 vaccine for cats & dogs as makers of Sputnik V warn pets & farm animals could spread virus'. The report said 'top scientists warned that the deadly pathogen could soon begin spreading through homes and farms' and 'the next stage is the infection of farm and domestic animals'. Know the outcome and you'll see the journey. Think what that would mean for animals and keep your eye on a term called zoonosis or zoonotic diseases which transmit between animals and humans. The Cult wants to break the connection between animals and people as it does between people and people. Farm animals fit with the Cult agenda to transform food from natural to synthetic.

### **The gas of life is killing us**

There can be few greater examples of Cult inversion than the condemnation of carbon dioxide as a dangerous pollutant when it is the gas of life. Without it the natural world would be dead and so we would all be dead. We breathe in oxygen and breathe out carbon dioxide while plants produce oxygen and absorb carbon dioxide. It is a perfect symbiotic relationship that the Cult wants to dismantle for reasons I will come to in the final two chapters. Gates, Schwab, other Cult operatives and mindless repeaters, want the world to be 'carbon neutral' by at least 2050 and the earlier the better. 'Zero carbon' is the cry echoed by lunatics calling for 'Zero Covid' when we already have it. These carbon emission targets will deindustrialise the world in accordance with Cult plans – the post-industrial, post-democratic society – and with so-called renewables like solar and wind not coming even close to meeting human energy needs blackouts and cold are inevitable. Texans got the picture in the winter of 2021 when a snow storm stopped wind turbines and solar panels from working and the lights went down along with water which relies on electricity for its supply system. Gates wants everything to be powered by electricity to ensure that his masters have the kill switch to stop all human activity, movement, cooking, water and warmth any time they like. The climate lie is so



stupendously inverted that it claims we must urgently reduce carbon dioxide when we *don't have enough*.

Co2 in the atmosphere is a little above 400 parts per million when the optimum for plant growth is 2,000 ppm and when it falls anywhere near 150 ppm the natural world starts to die and so do we. It fell to as low as 280 ppm in an 1880 measurement in Hawaii and rose to 413 ppm in 2019 with industrialisation which is why the planet has become *greener* in the industrial period. How insane then that psychopathic madman Gates is not satisfied only with blocking the rise of Co2. He's funding technology to suck it out of the atmosphere. The reason why will become clear. The industrial era is not destroying the world through Co2 and has instead turned around a potentially disastrous ongoing fall in Co2. Greenpeace co-founder and scientist Patrick Moore walked away from Greenpeace in 1986 and has exposed the green movement for fear-mongering and lies. He said that 500 million years ago there was *17 times* more Co2 in the atmosphere than we have today and levels have been falling for hundreds of millions of years. In the last 150 million years Co2 levels in Earth's atmosphere had reduced by *90 percent*. Moore said that by the time humanity began to unlock carbon dioxide from fossil fuels we were at '38 seconds to midnight' and in that sense: 'Humans are [the Earth's] salvation.' Moore made the point that only half the Co2 emitted by fossil fuels stays in the atmosphere and we should remember that all pollution pouring from chimneys that we are told is carbon dioxide is in fact nothing of the kind. It's pollution. Carbon dioxide is an invisible gas.

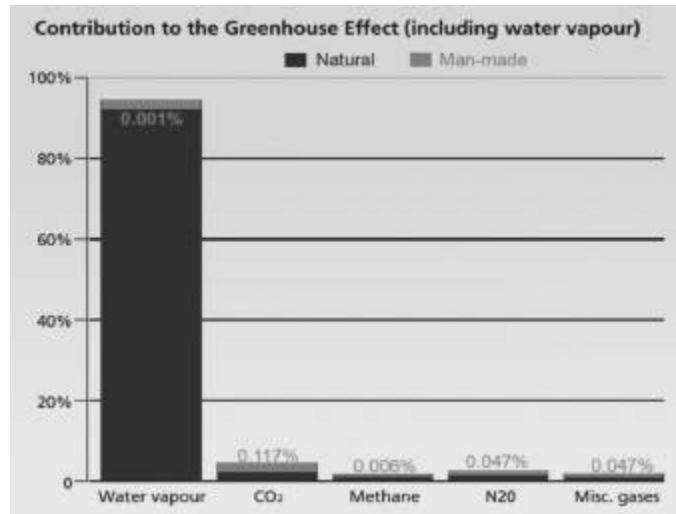
William Happer, Professor of Physics at Princeton University and long-time government adviser on climate, has emphasised the Co2 deficiency for maximum growth and food production. Greenhouse growers don't add carbon dioxide for a bit of fun. He said that most of the warming in the last 100 years, after the earth emerged from the super-cold period of the 'Little Ice Age' into a natural warming cycle, was over by 1940. Happer said that a peak year for warming in 1988 can be explained by a 'monster El Nino' which is a natural and cyclical warming of the Pacific that has nothing to do with 'climate

change'. He said the effect of Co2 could be compared to painting a wall with red paint in that once two or three coats have been applied it didn't matter how much more you slapped on because the wall will not get much redder. Almost all the effect of the rise in Co2 has already happened, he said, and the volume in the atmosphere would now have to *double* to increase temperature by a single degree. Climate hoaxers know this and they have invented the most ridiculously complicated series of 'feedback' loops to try to overcome this rather devastating fact. You hear puppet Greta going on cluelessly about feedback loops and this is why.

### **The Sun affects temperature? No you *climate denier***

Some other nonsense to contemplate: Climate graphs show that rises in temperature do not follow rises in Co2 – *it's the other way round* with a lag between the two of some 800 years. If we go back 800 years from present time we hit the Medieval Warm Period when temperatures were higher than now without any industrialisation and this was followed by the Little Ice Age when temperatures plummeted. The world was still emerging from these centuries of serious cold when many climate records began which makes the ever-repeated line of the 'hottest year since records began' meaningless when you are not comparing like with like. The coldest period of the Little Ice Age corresponded with the lowest period of sunspot activity when the Sun was at its least active. Proper scientists will not be at all surprised by this when it confirms the obvious fact that earth temperature is affected by the scale of Sun activity and the energetic power that it subsequently emits; but when is the last time you heard a climate hoaxer talking about the Sun as a source of earth temperature?? Everything has to be focussed on Co2 which makes up just 0.117 percent of so-called greenhouse gases and only a fraction of even that is generated by human activity. The rest is natural. More than *90 percent* of those greenhouse gases are water vapour and clouds ([Fig 9](#)). Ban moisture I say. Have you noticed that the climate hoaxers no longer use the polar bear as their promotion image? That's because far from becoming extinct polar

bear communities are stable or thriving. Joe Bastardi, American meteorologist, weather forecaster and outspoken critic of the climate lie, documents in his book *The Climate Chronicles* how weather patterns and events claimed to be evidence of climate change have been happening since long before industrialisation: 'What happened before naturally is happening again, as is to be expected given the cyclical nature of the climate due to the design of the planet.' If you read the detailed background to the climate hoax in my other books you will shake your head and wonder how anyone could believe the crap which has spawned a multi-trillion dollar industry based on absolute garbage (see HIV causes AIDs and Sars-Cov-2 causes 'Covid-19'). Climate and 'Covid' have much in common given they have the same source. They both have the contradictory *everything* factor in which everything is explained by reference to them. It's hot – 'it's climate change'. It's cold – 'it's climate change'. I got a sniffle – 'it's Covid'. I haven't got a sniffle – 'it's Covid'. Not having a sniffle has to be a symptom of 'Covid'. Everything is and not having a sniffle is especially dangerous if you are a slow walker. For sheer audacity I offer you a Cambridge University 'study' that actually linked 'Covid' to 'climate change'. It had to happen eventually. They concluded that climate change played a role in 'Covid-19' spreading from animals to humans because ... wait for it ... I kid you not ... *the two groups were forced closer together as populations grow*. Er, that's it. The whole foundation on which this depended was that 'Bats are the likely zoonotic origin of SARS-CoV-1 and SARS-CoV-2'. Well, they are not. They are nothing to do with it. Apart from bats not being the origin and therefore 'climate change' effects on bats being irrelevant I am in awe of their academic insight. Where would we be without them? Not where we are that's for sure.



**Figure 9:** The idea that the gas of life is disastrously changing the climate is an insult to brain cell activity.

One other point about the weather is that climate modification is now well advanced and not every major weather event is natural – or earthquake come to that. I cover this subject at some length in other books. China is openly planning a rapid expansion of its weather modification programme which includes changing the climate in an area more than one and a half times the size of India. China used weather manipulation to ensure clear skies during the 2008 Olympics in Beijing. I have quoted from US military documents detailing how to employ weather manipulation as a weapon of war and they did that in the 1960s and 70s during the conflict in Vietnam with Operation Popeye manipulating monsoon rains for military purposes. Why would there be international treaties on weather modification if it wasn't possible? Of course it is. Weather is energetic information and it can be changed.

### **How was the climate hoax pulled off? See 'Covid'**

If you can get billions to believe in a 'virus' that doesn't exist you can get them to believe in human-caused climate change that doesn't exist. Both are being used by the Cult to transform global society in the way it has long planned. Both hoaxes have been achieved in pretty much the same way. First you declare a lie is a fact. There's a

'virus' you call SARS-Cov-2 or humans are warming the planet with their behaviour. Next this becomes, via Cult networks, the foundation of government, academic and science policy and belief. Those who parrot the mantra are given big grants to produce research that confirms the narrative is true and ever more 'symptoms' are added to make the 'virus'/'climate change' sound even more scary. Scientists and researchers who challenge the narrative have their grants withdrawn and their careers destroyed. The media promote the lie as the unquestionable truth and censor those with an alternative view or evidence. A great percentage of the population believe what they are told as the lie becomes an everybody-knows-that and the believing-masses turn on those with a mind of their own. The technique has been used endlessly throughout human history. Wokers are the biggest promoters of the climate lie *and* 'Covid' fascism because their minds are owned by the Cult; their sense of self-righteous self-purity knows no bounds; and they exist in a bubble of reality in which facts are irrelevant and only get in the way of looking without seeing.

Running through all of this like veins in a blue cheese is control of information, which means control of perception, which means control of behaviour, which collectively means control of human society. The Cult owns the global media and Silicon Valley fascists for the simple reason that it *has* to. Without control of information it can't control perception and through that human society. Examine every facet of the Cult agenda and you will see that anything supporting its introduction is never censored while anything pushing back is always censored. I say again: Psychopaths that know why they are doing this must go before Nuremberg trials and those that follow their orders must trot along behind them into the same dock. 'I was just following orders' didn't work the first time and it must not work now. Nuremberg trials must be held all over the world before public juries for politicians, government officials, police, compliant doctors, scientists and virologists, and all Cult operatives such as Gates, Tedros, Fauci, Vallance, Whitty, Ferguson, Zuckerberg, Wojcicki, Brin, Page, Dorsey, the whole damn lot of

them – including, no *especially*, the psychopath psychologists. Without them and the brainless, gutless excuses for journalists that have repeated their lies, none of this could be happening. Nobody can be allowed to escape justice for the psychological and economic Armageddon they are all responsible for visiting upon the human race.

As for the compliant, unquestioning, swathes of humanity, and the self-obsessed, all-knowing ignorance of the Wokers ... don't start me. God help their kids. God help their grandkids. God *help them*.

## CHAPTER NINE

### **We must have it? So what is it?**

*Well I won't back down. No, I won't back down. You can stand me up at the Gates of Hell. But I won't back down*

**Tom Petty**

I will now focus on the genetically-manipulating 'Covid vaccines' which do not meet this official definition of a vaccine by the US Centers for Disease Control (CDC): 'A product that stimulates a person's immune system to produce immunity to a specific disease, protecting the person from that disease.' On that basis 'Covid vaccines' are not a vaccine in that the makers don't even claim they stop infection or transmission.

They are instead part of a multi-levelled conspiracy to change the nature of the human body and what it means to be 'human' and to depopulate an enormous swathe of humanity. What I shall call Human 1.0 is on the cusp of becoming Human 2.0 and for very sinister reasons. Before I get to the 'Covid vaccine' in detail here's some background to vaccines in general. Government regulators do not test vaccines – the makers do – and the makers control which data is revealed and which isn't. Children in America are given 50 vaccine doses by age six and 69 by age 19 and the effect of the whole combined schedule has never been tested. Autoimmune diseases when the immune system attacks its own body have soared in the mass vaccine era and so has disease in general in children and the young. Why wouldn't this be the case when vaccines target the *immune system*? The US government gave Big Pharma drug

companies immunity from prosecution for vaccine death and injury in the 1986 National Childhood Vaccine Injury Act (NCVIA) and since then the government (taxpayer) has been funding compensation for the consequences of Big Pharma vaccines. The criminal and satanic drug giants can't lose and the vaccine schedule has increased dramatically since 1986 for this reason. There is no incentive to make vaccines safe and a big incentive to make money by introducing ever more. Even against a ridiculously high bar to prove vaccine liability, and with the government controlling the hearing in which it is being challenged for compensation, the vaccine court has so far paid out more than \$4 billion. These are the vaccines we are told are safe and psychopaths like Zuckerberg censor posts saying otherwise. The immunity law was even justified by a ruling that vaccines by their nature were 'unavoidably unsafe'.

Check out the ingredients of vaccines and you will be shocked if you are new to this. *They put that in children's bodies?? What??* Try aluminium, a brain toxin connected to dementia, aborted foetal tissue and formaldehyde which is used to embalm corpses. World-renowned aluminium expert Christopher Exley had his research into the health effect of aluminium in vaccines shut down by Keele University in the UK when it began taking funding from the Bill and Melinda Gates Foundation. Research when diseases 'eradicated' by vaccines began to decline and you will find the fall began long *before* the vaccine was introduced. Sometimes the fall even plateaued after the vaccine. Diseases like scarlet fever for which there was no vaccine declined in the same way because of environmental and other factors. A perfect case in point is the polio vaccine. Polio began when lead arsenate was first sprayed as an insecticide and residues remained in food products. Spraying started in 1892 and the first US polio epidemic came in Vermont in 1894. The simple answer was to stop spraying, but Rockefeller-created Big Pharma had a better idea. Polio was decreed to be caused by the *poliovirus* which 'spreads from person to person and can infect a person's spinal cord'. Lead arsenate was replaced by the lethal DDT which had the same effect of causing paralysis by damaging the brain and central nervous



system. Polio plummeted when DDT was reduced and then banned, but the vaccine is still given the credit for something it didn't do. Today by far the biggest cause of polio is the vaccines promoted by Bill Gates. Vaccine justice campaigner Robert Kennedy Jr, son of assassinated (by the Cult) US Attorney General Robert Kennedy, wrote:

In 2017, the World Health Organization (WHO) reluctantly admitted that the global explosion in polio is predominantly vaccine strain. The most frightening epidemics in Congo, Afghanistan, and the Philippines, are all linked to vaccines. In fact, by 2018, 70% of global polio cases were vaccine strain.

Vaccines make fortunes for Cult-owned Gates and Big Pharma while undermining the health and immune systems of the population. We had a glimpse of the mentality behind the Big Pharma cartel with a report on WION (World is One News), an international English language TV station based in India, which exposed the extraordinary behaviour of US drug company Pfizer over its 'Covid vaccine'. The WION report told how Pfizer had made fantastic demands of Argentina, Brazil and other countries in return for its 'vaccine'. These included immunity from prosecution, even for Pfizer negligence, government insurance to protect Pfizer from law suits and handing over as collateral sovereign assets of the country to include Argentina's bank reserves, military bases and embassy buildings. Pfizer demanded the same of Brazil in the form of waiving sovereignty of its assets abroad; exempting Pfizer from Brazilian laws; and giving Pfizer immunity from all civil liability. This is a 'vaccine' developed with government funding. Big Pharma is evil incarnate as a creation of the Cult and all must be handed tickets to Nuremberg.

### **Phantom 'vaccine' for a phantom 'disease'**

I'll expose the 'Covid vaccine' fraud and then go on to the wider background of why the Cult has set out to 'vaccinate' every man, woman and child on the planet for an alleged 'new disease' with a survival rate of 99.77 percent (or more) even by the grotesquely-

manipulated figures of the World Health Organization and Johns Hopkins University. The 'infection' to 'death' ratio is 0.23 to 0.15 percent according to Stanford epidemiologist Dr John Ioannidis and while estimates vary the danger remains tiny. I say that if the truth be told the fake infection to fake death ratio is zero. Never mind all the evidence I have presented here and in *The Answer* that there is no 'virus' let us just focus for a moment on that death-rate figure of say 0.23 percent. The figure includes all those worldwide who have tested positive with a test not testing for the 'virus' and then died within 28 days or even longer of any other cause – *any other cause*. Now subtract all those illusory 'Covid' deaths on the global data sheets from the 0.23 percent. What do you think you would be left with? *Zero*. A vaccination has never been successfully developed for a so-called coronavirus. They have all failed at the animal testing stage when they caused hypersensitivity to what they were claiming to protect against and made the impact of a disease far worse. Cult-owned vaccine corporations got around that problem this time by bypassing animal trials, going straight to humans and making the length of the 'trials' before the public rollout as short as they could get away with. Normally it takes five to ten years or more to develop vaccines that still cause demonstrable harm to many people and that's without including the long-term effects that are never officially connected to the vaccination. 'Covid' non-vaccines have been officially produced and approved in a matter of months from a standing start and part of the reason is that (a) they were developed before the 'Covid' hoax began and (b) they are based on computer programs and not natural sources. Official non-trials were so short that government agencies gave *emergency*, not full, approval. 'Trials' were not even completed and full approval cannot be secured until they are. Public 'Covid vaccination' is actually a *continuation of the trial*. Drug company 'trials' are not scheduled to end until 2023 by which time a lot of people are going to be dead. Data on which government agencies gave this emergency approval was supplied by the Big Pharma corporations themselves in the form of Pfizer/BioNTech, AstraZeneca, Moderna, Johnson & Johnson, and

others, and this is the case with all vaccines. By its very nature *emergency* approval means drug companies do not have to prove that the 'vaccine' is 'safe and effective'. How could they with trials way short of complete? Government regulators only have to *believe* that they *could* be safe and effective. It is criminal manipulation to get products in circulation with no testing worth the name. Agencies giving that approval are infested with Big Pharma-connected place-people and they act in the interests of Big Pharma (the Cult) and not the public about whom they do not give a damn.

### **More human lab rats**

'Covid vaccines' produced in record time by Pfizer/BioNTech and Moderna employ a technique *never approved before for use on humans*. They are known as mRNA 'vaccines' and inject a synthetic version of 'viral' mRNA or 'messenger RNA'. The key is in the term 'messenger'. The body works, or doesn't, on the basis of information messaging. Communications are constantly passing between and within the genetic system and the brain. Change those messages and you change the state of the body and even its very nature and you can change psychology and behaviour by the way the brain processes information. I think you are going to see significant changes in personality and perception of many people who have had the 'Covid vaccine' synthetic potions. Insider Aldous Huxley predicted the following in 1961 and mRNA 'vaccines' can be included in the term 'pharmacological methods':

There will be, in the next generation or so, a pharmacological method of making people love their servitude, and producing dictatorship without tears, so to speak, producing a kind of painless concentration camp for entire societies, so that people will in fact have their own liberties taken away from them, but rather enjoy it, because they will be distracted from any desire to rebel by propaganda or brainwashing, or brainwashing enhanced by pharmacological methods. And this seems to be the final revolution.

Apologists claim that mRNA synthetic 'vaccines' don't change the DNA genetic blueprint because RNA does not affect DNA only the other way round. This is so disingenuous. A process called 'reverse

transcription' can convert RNA into DNA and be integrated into DNA in the cell nucleus. This was highlighted in December, 2020, by scientists at Harvard and Massachusetts Institute of Technology (MIT). Geneticists report that more than 40 percent of mammalian genomes results from reverse transcription. On the most basic level if messaging changes then that sequence must lead to changes in DNA which is receiving and transmitting those communications. How can introducing synthetic material into cells not change the cells where DNA is located? The process is known as transfection which is defined as 'a technique to insert foreign nucleic acid (DNA or RNA) into a cell, typically with the intention of altering the properties of the cell'. Researchers at the Sloan Kettering Institute in New York found that changes in messenger RNA can deactivate tumour-suppressing proteins and thereby promote cancer. This is what happens when you mess with messaging. 'Covid vaccine' maker Moderna was founded in 2010 by Canadian stem cell biologist Derrick J. Rossi after his breakthrough discovery in the field of transforming and reprogramming stem cells. These are neutral cells that can be programmed to become any cell including sperm cells. Moderna was therefore founded on the principle of genetic manipulation and has never produced any vaccine or drug before its genetically-manipulating synthetic 'Covid' shite. Look at the name – Mode-RNA or Modify-RNA. Another important point is that the US Supreme Court has ruled that genetically-modified DNA, or complementary DNA (cDNA) synthesized in the laboratory from messenger RNA, can be patented and owned. These psychopaths are doing this to the human body.

Cells replicate synthetic mRNA in the 'Covid vaccines' and in theory the body is tricked into making antigens which trigger antibodies to target the 'virus spike proteins' which as Dr Tom Cowan said have *never been seen*. Cut the crap and these 'vaccines' deliver *self-replicating* synthetic material to the cells with the effect of changing human DNA. The more of them you have the more that process is compounded while synthetic material is all the time self-replicating. 'Vaccine'-maker Moderna describes mRNA as 'like

software for the cell' and so they are messing with the body's software. What happens when you change the software in a computer? Everything changes. For this reason the Cult is preparing a production line of mRNA 'Covid vaccines' and a long list of excuses to use them as with all the 'variants' of a 'virus' never shown to exist. The plan is further to transfer the mRNA technique to other vaccines mostly given to children and young people. The cumulative consequences will be a transformation of human DNA through a constant infusion of synthetic genetic material which will kill many and change the rest. Now consider that governments that have given emergency approval for a vaccine that's not a vaccine; never been approved for humans before; had no testing worth the name; and the makers have been given immunity from prosecution for any deaths or adverse effects suffered by the public. The UK government awarded *permanent legal indemnity* to itself and its employees for harm done when a patient is being treated for 'Covid-19' or 'suspected Covid-19'. That is quite a thought when these are possible 'side-effects' from the 'vaccine' (they are not 'side', they are effects) listed by the US Food and Drug Administration:

Guillain-Barre syndrome; acute disseminated encephalomyelitis; transverse myelitis; encephalitis; myelitis; encephalomyelitis; meningoencephalitis; meningitis; encephalopathy; convulsions; seizures; stroke; narcolepsy; cataplexy; anaphylaxis; acute myocardial infarction (heart attack); myocarditis; pericarditis; autoimmune disease; death; implications for pregnancy, and birth outcomes; other acute demyelinating diseases; non anaphylactic allergy reactions; thrombocytopenia ; disseminated intravascular coagulation; venous thromboembolism; arthritis; arthralgia; joint pain; Kawasaki disease; multisystem inflammatory syndrome in children; vaccine enhanced disease. The latter is the way the 'vaccine' has the potential to make diseases far worse than they would otherwise be.

UK doctor and freedom campaigner Vernon Coleman described the conditions in this list as 'all unpleasant, most of them very serious, and you can't get more serious than death'. The thought that anyone at all has had the 'vaccine' in these circumstances is testament to the potential that humanity has for clueless, unquestioning, stupidity and for many that programmed stupidity has already been terminal.

## **An insider speaks**

Dr Michael Yeadon is a former Vice President, head of research and Chief Scientific Adviser at vaccine giant Pfizer. Yeadon worked on the inside of Big Pharma, but that did not stop him becoming a vocal critic of 'Covid vaccines' and their potential for multiple harms, including infertility in women. By the spring of 2021 he went much further and even used the no, no, term 'conspiracy'. When you begin to see what is going on it is impossible not to do so. Yeadon spoke out in an interview with freedom campaigner James Delingpole and I mentioned earlier how he said that no one had samples of 'the virus'. He explained that the mRNA technique originated in the anti-cancer field and ways to turn on and off certain genes which could be advantageous if you wanted to stop cancer growing out of control. 'That's the origin of them. They are a very unusual application, really.' Yeadon said that treating a cancer patient with an aggressive procedure might be understandable if the alternative was dying, but it was quite another thing to use the same technique as a public health measure. Most people involved wouldn't catch the infectious agent you were vaccinating against and if they did they probably wouldn't die:

If you are really using it as a public health measure you really want to as close as you can get to zero sides-effects ... I find it odd that they chose techniques that were really cutting their teeth in the field of oncology and I'm worried that in using gene-based vaccines that have to be injected in the body and spread around the body, get taken up into some cells, and the regulators haven't quite told us which cells they get taken up into ... you are going to be generating a wide range of responses ... with multiple steps each of which could go well or badly.

I doubt the Cult intends it to go well. Yeadon said that you can put any gene you like into the body through the 'vaccine'. 'You can certainly give them a gene that would do them some harm if you wanted.' I was intrigued when he said that when used in the cancer field the technique could turn genes on and off. I explore this process in *The Answer* and with different genes having different functions you could create mayhem – physically and psychologically – if you turned the wrong ones on and the right ones off. I read reports of an experiment by researchers at the University of Washington's school of computer science and engineering in which they encoded DNA to infect computers. The body is itself a biological computer and if human DNA can inflict damage on a computer why can't the computer via synthetic material mess with the human body? It can. The Washington research team said it was possible to insert malicious malware into 'physical DNA strands' and corrupt the computer system of a gene sequencing machine as it 'reads gene letters and stores them as binary digits 0 and 1'. They concluded that hackers could one day use blood or spit samples to access computer systems and obtain sensitive data from police forensics labs or infect genome files. It is at this level of digital interaction that synthetic 'vaccines' need to be seen to get the full picture and that will become very clear later on. Michael Yeadon said it made no sense to give the 'vaccine' to younger people who were in no danger from the 'virus'. What was the benefit? It was all downside with potential effects:

The fact that my government in what I thought was a civilised, rational country, is raining [the 'vaccine'] on people in their 30s and 40s, even my children in their 20s, they're getting letters and phone calls, I know this is not right and any of you doctors who are vaccinating you know it's not right, too. They are not at risk. They are not at risk from the disease, so you are now hoping that the side-effects are so rare that you get away with it. You don't give new technology ... that you don't understand to 100 percent of the population.

Blood clot problems with the AstraZeneca 'vaccine' have been affecting younger people to emphasise the downside risks with no benefit. AstraZeneca's version, produced with Oxford University, does not use mRNA, but still gets its toxic cocktail inside cells where

it targets DNA. The Johnson & Johnson 'vaccine' which uses a similar technique has also produced blood clot effects to such an extent that the United States paused its use at one point. They are all 'gene therapy' (cell modification) procedures and not 'vaccines'. The truth is that once the content of these injections enter cells we have no idea what the effect will be. People can speculate and some can give very educated opinions and that's good. In the end, though, only the makers know what their potions are designed to do and even they won't know every last consequence. Michael Yeadon was scathing about doctors doing what they knew to be wrong. 'Everyone's mute', he said. Doctors in the NHS must know this was not right, coming into work and injecting people. 'I don't know how they sleep at night. I know I couldn't do it. I know that if I were in that position I'd have to quit.' He said he knew enough about toxicology to know this was not a good risk-benefit. Yeadon had spoken to seven or eight university professors and all except two would not speak out publicly. Their universities had a policy that no one said anything that countered the government and its medical advisors. They were afraid of losing their government grants. This is how intimidation has been used to silence the truth at every level of the system. I say silence, but these people could still speak out if they made that choice. Yeadon called them 'moral cowards' – 'This is about your children and grandchildren's lives and you have just buggered off and left it.'

### **'Variant' nonsense**

Some of his most powerful comments related to the alleged 'variants' being used to instil more fear, justify more lockdowns, and introduce more 'vaccines'. He said government claims about 'variants' were nonsense. He had checked the alleged variant 'codes' and they were 99.7 percent identical to the 'original'. This was the human identity difference equivalent to putting a baseball cap on and off or wearing it the other way round. A 0.3 percent difference would make it impossible for that 'variant' to escape immunity from the 'original'. This made no sense of having new 'vaccines' for



'variants'. He said there would have to be at least a *30 percent* difference for that to be justified and even then he believed the immune system would still recognise what it was. Gates-funded 'variant modeller' and 'vaccine'-pusher John Edmunds might care to comment. Yeadon said drug companies were making new versions of the 'vaccine' as a 'top up' for 'variants'. Worse than that, he said, the 'regulators' around the world like the MHRA in the UK had got together and agreed that because 'vaccines' for 'variants' were so similar to the first 'vaccines' *they did not have to do safety studies*. How transparently sinister that is. This is when Yeadon said: 'There is a conspiracy here.' There was no need for another vaccine for 'variants' and yet we were told that there was and the country had shut its borders because of them. 'They are going into hundreds of millions of arms without passing 'go' or any regulator. Why did they do that? Why did they pick this method of making the vaccine?'

The reason had to be something bigger than that it seemed and 'it's not protection against the virus'. It's was a far bigger project that meant politicians and advisers were willing to do things and not do things that knowingly resulted in avoidable deaths – 'that's already happened when you think about lockdown and deprivation of health care for a year.' He spoke of people prepared to do something that results in the avoidable death of their fellow human beings and it not bother them. This is the penny-drop I have been working to get across for more than 30 years – the level of pure evil we are dealing with. Yeadon said his friends and associates could not believe there could be that much evil, but he reminded them of Stalin, Pol Pot and Hitler and of what Stalin had said: 'One death is a tragedy. A million? A statistic.' He could not think of a benign explanation for why you need top-up vaccines 'which I'm sure you don't' and for the regulators 'to just get out of the way and wave them through'. Why would the regulators do that when they were still wrestling with the dangers of the 'parent' vaccine? He was clearly shocked by what he had seen since the 'Covid' hoax began and now he was thinking the previously unthinkable:

If you wanted to depopulate a significant proportion of the world and to do it in a way that doesn't involve destruction of the environment with nuclear weapons, poisoning everyone with anthrax or something like that, and you wanted plausible deniability while you had a multi-year infectious disease crisis, I actually don't think you could come up with a better plan of work than seems to be in front of me. I can't say that's what they are going to do, but I can't think of a benign explanation why they are doing it.

He said he never thought that they would get rid of 99 percent of humans, but now he wondered. 'If you wanted to that this would be a hell of a way to do it – it would be unstoppable folks.' Yeadon had concluded that those who submitted to the 'vaccine' would be allowed to have some kind of normal life (but for how long?) while screws were tightened to coerce and mandate the last few percent. 'I think they'll put the rest of them in a prison camp. I wish I was wrong, but I don't think I am.' Other points he made included: There were no coronavirus vaccines then suddenly they all come along at the same time; we have no idea of the long term affect with trials so short; coercing or forcing people to have medical procedures is against the Nuremberg Code instigated when the Nazis did just that; people should at least delay having the 'vaccine'; a quick Internet search confirms that masks don't reduce respiratory viral transmission and 'the government knows that'; they have smashed civil society and they know that, too; two dozen peer-reviewed studies show no connection between lockdown and reducing deaths; he knew from personal friends the elite were still flying around and going on holiday while the public were locked down; the elite were not having the 'vaccines'. He was also asked if 'vaccines' could be made to target difference races. He said he didn't know, but the document by the Project for the New American Century in September, 2000, said developing 'advanced forms of biological warfare that can target *specific genotypes* may transform biological warfare from the realm of terror to a politically useful tool.' Oh, they're evil all right. Of that we can be *absolutely* sure.

## **Another cull of old people**

We have seen from the CDC definition that the mRNA 'Covid vaccine' is not a vaccine and nor are the others that *claim* to reduce 'severity of symptoms' in *some* people, but not protect from infection or transmission. What about all the lies about returning to 'normal' if people were 'vaccinated'? If they are not claimed to stop infection and transmission of the alleged 'virus', how does anything change? This was all lies to manipulate people to take the jabs and we are seeing that now with masks and distancing still required for the 'vaccinated'. How did they think that elderly people with fragile health and immune responses were going to be affected by infusing their cells with synthetic material and other toxic substances? They *knew* that in the short and long term it would be devastating and fatal as the culling of the old that began with the first lockdowns was continued with the 'vaccine'. Death rates in care homes soared immediately residents began to be 'vaccinated' – infused with synthetic material. Brave and committed whistleblower nurses put their careers at risk by exposing this truth while the rest kept their heads down and their mouths shut to put their careers before those they are supposed to care for. A long-time American Certified Nursing Assistant who gave his name as James posted a video in which he described emotionally what happened in his care home when vaccination began. He said that during 2020 very few residents were sick with 'Covid' and no one died during the entire year; but shortly after the Pfizer mRNA injections 14 people died within two weeks and many others were near death. 'They're dropping like flies', he said. Residents who walked on their own before the shot could no longer and they had lost their ability to conduct an intelligent conversation. The home's management said the sudden deaths were caused by a 'super-spreader' of 'Covid-19'. Then how come, James asked, that residents who refused to take the injections were not sick? It was a case of inject the elderly with mRNA synthetic potions and blame their illness and death that followed on the 'virus'. James described what was happening in care homes as 'the greatest crime of genocide this country has ever seen'. Remember the NHS staff nurse from earlier who used the same

word 'genocide' for what was happening with the 'vaccines' and that it was an 'act of human annihilation'. A UK care home whistleblower told a similar story to James about the effect of the 'vaccine' in deaths and 'outbreaks' of illness dubbed 'Covid' after getting the jab. She told how her care home management and staff had zealously imposed government regulations and no one was allowed to even question the official narrative let alone speak out against it. She said the NHS was even worse. Again we see the results of reframing. A worker at a local care home where I live said they had not had a single case of 'Covid' there for almost a year and when the residents were 'vaccinated' they had 19 positive cases in two weeks with eight dying.

### **It's not the 'vaccine' – honest**

The obvious cause and effect was being ignored by the media and most of the public. Australia's health minister Greg Hunt (a former head of strategy at the World Economic Forum) was admitted to hospital after he had the 'vaccine'. He was suffering according to reports from the skin infection 'cellulitis' and it must have been a severe case to have warranted days in hospital. Immediately the authorities said this was nothing to do with the 'vaccine' when an effect of some vaccines is a 'cellulitis-like reaction'. We had families of perfectly healthy old people who died after the 'vaccine' saying that if only they had been given the 'vaccine' earlier they would still be alive. As a numbskull rating that is off the chart. A father of four 'died of Covid' at aged 48 when he was taken ill two days after having the 'vaccine'. The man, a health administrator, had been 'shielding during the pandemic' and had 'not really left the house' until he went for the 'vaccine'. Having the 'vaccine' and then falling ill and dying does not seem to have qualified as a possible cause and effect and 'Covid-19' went on his death certificate. His family said they had no idea how he 'caught the virus'. A family member said: 'Tragically, it could be that going for a vaccination ultimately led to him catching Covid ...The sad truth is that they are never going to know where it came from.' The family warned people to remember

that the virus still existed and was 'very real'. So was their stupidity. Nurses and doctors who had the first round of the 'vaccine' were collapsing, dying and ending up in a hospital bed while they or their grieving relatives were saying they'd still have the 'vaccine' again despite what happened. I kid you not. You mean if your husband returned from the dead he'd have the same 'vaccine' again that killed him??

Doctors at the VCU Medical Center in Richmond, Virginia, said the Johnson & Johnson 'vaccine' was to blame for a man's skin peeling off. Patient Richard Terrell said: 'It all just happened so fast. My skin peeled off. It's still coming off on my hands now.' He said it was stinging, burning and itching and when he bent his arms and legs it was very painful with 'the skin swollen and rubbing against itself'. Pfizer/BioNTech and Moderna vaccines use mRNA to change the cell while the Johnson & Johnson version uses DNA in a process similar to AstraZeneca's technique. Johnson & Johnson and AstraZeneca have both had their 'vaccines' paused by many countries after causing serious blood problems. Terrell's doctor Fnu Nutan said he could have died if he hadn't got medical attention. It sounds terrible so what did Nutan and Terrell say about the 'vaccine' now? Oh, they still recommend that people have it. A nurse in a hospital bed 40 minutes after the vaccination and unable to swallow due to throat swelling was told by a doctor that he lost mobility in his arm for 36 hours following the vaccination. What did he say to the ailing nurse? 'Good for you for getting the vaccination.' We are dealing with a serious form of cognitive dissonance madness in both public and medical staff. There is a remarkable correlation between those having the 'vaccine' and trumpeting the fact and suffering bad happenings shortly afterwards. Witold Rogiewicz, a Polish doctor, made a video of his 'vaccination' and ridiculed those who were questioning its safety and the intentions of Bill Gates: 'Vaccinate yourself to protect yourself, your loved ones, friends and also patients. And to mention quickly I have info for anti-vaxxers and anti-Coviders if you want to contact Bill Gates you can do this through me.' He further ridiculed the dangers of 5G. Days later he

was dead, but naturally the vaccination wasn't mentioned in the verdict of 'heart attack'.

## **Lies, lies and more lies**

So many members of the human race have slipped into extreme states of insanity and unfortunately they include reframed doctors and nursing staff. Having a 'vaccine' and dying within minutes or hours is not considered a valid connection while death from any cause within 28 days or longer of a positive test with a test not testing for the 'virus' means 'Covid-19' goes on the death certificate. How could that 'vaccine'-death connection not have been made except by calculated deceit? US figures in the initial rollout period to February 12th, 2020, revealed that a third of the deaths reported to the CDC after 'Covid vaccines' happened within 48 hours. Five men in the UK suffered an 'extremely rare' blood clot problem after having the AstraZeneca 'vaccine', but no causal link was established said the Gates-funded Medicines and Healthcare products Regulatory Agency (MHRA) which had given the 'vaccine' emergency approval to be used. Former Pfizer executive Dr Michael Yeadon explained in his interview how the procedures could cause blood coagulation and clots. People who should have been at no risk were dying from blood clots in the brain and he said he had heard from medical doctor friends that people were suffering from skin bleeding and massive headaches. The AstraZeneca 'shot' was stopped by some 20 countries over the blood clotting issue and still the corrupt MHRA, the European Medicines Agency (EMA) and the World Health Organization said that it should continue to be given even though the EMA admitted that it 'still cannot rule out definitively' a link between blood clotting and the 'vaccine'. Later Marco Cavaleri, head of EMA vaccine strategy, said there was indeed a clear link between the 'vaccine' and thrombosis, but they didn't know why. So much for the trials showing the 'vaccine' is safe. Blood clots were affecting younger people who would be under virtually no danger from 'Covid' even if it existed which makes it all the more stupid and sinister.

The British government responded to public alarm by wheeling out June Raine, the terrifyingly weak infant school headmistress sound-alike who heads the UK MHRA drug 'regulator'. The idea that she would stand up to Big Pharma and government pressure is laughable and she told us that all was well in the same way that she did when allowing untested, never-used-on-humans-before, genetically-manipulating 'vaccines' to be exposed to the public in the first place. Mass lying is the new normal of the 'Covid' era. The MHRA later said 30 cases of rare blood clots had by then been connected with the AstraZeneca 'vaccine' (that means a lot more in reality) while stressing that the benefits of the jab in preventing 'Covid-19' outweighed any risks. A more ridiculous and disingenuous statement with callous disregard for human health it is hard to contemplate. Immediately after the mendacious 'all-clears' two hospital workers in Denmark experienced blood clots and cerebral haemorrhaging following the AstraZeneca jab and one died. Top Norwegian health official Pål Andre Holme said the 'vaccine' was the only common factor: 'There is nothing in the patient history of these individuals that can give such a powerful immune response ... I am confident that the antibodies that we have found are the cause, and I see no other explanation than it being the vaccine which triggers it.' Strokes, a clot or bleed in the brain, were clearly associated with the 'vaccine' from word of mouth and whistleblower reports. Similar consequences followed with all these 'vaccines' that we were told were so safe and as the numbers grew by the day it was clear we were witnessing human carnage.

### **Learning the hard way**

A woman interviewed by UKColumn told how her husband suffered dramatic health effects after the vaccine when he'd been in good health all his life. He went from being a little unwell to losing all feeling in his legs and experiencing 'excruciating pain'. Misdiagnosis followed twice at Accident and Emergency (an 'allergy' and 'sciatica') before he was admitted to a neurology ward where doctors said his serious condition had been caused by the

'vaccine'. Another seven 'vaccinated' people were apparently being treated on the same ward for similar symptoms. The woman said he had the 'vaccine' because they believed media claims that it was safe. 'I didn't think the government would give out a vaccine that does this to somebody; I believed they would be bringing out a vaccination that would be safe.' What a tragic way to learn that lesson. Another woman posted that her husband was transporting stroke patients to hospital on almost every shift and when he asked them if they had been 'vaccinated' for 'Covid' they all replied 'yes'. One had a 'massive brain bleed' the day after his second dose. She said her husband reported the 'just been vaccinated' information every time to doctors in A and E only for them to ignore it, make no notes and appear annoyed that it was even mentioned. This particular report cannot be verified, but it expresses a common theme that confirms the monumental underreporting of 'vaccine' consequences. Interestingly as the 'vaccines' and their brain blood clot/stroke consequences began to emerge the UK National Health Service began a publicity campaign telling the public what to do in the event of a stroke. A Scottish NHS staff nurse who quit in disgust in March, 2021, said:

I have seen traumatic injuries from the vaccine, they're not getting reported to the yellow card [adverse reaction] scheme, they're treating the symptoms, not asking why, why it's happening. It's just treating the symptoms and when you speak about it you're dismissed like you're crazy, I'm not crazy, I'm not crazy because every other colleague I've spoken to is terrified to speak out, they've had enough.

Videos appeared on the Internet of people uncontrollably shaking after the 'vaccine' with no control over muscles, limbs and even their face. A Scottish mother broke out in a severe rash all over her body almost immediately after she was given the AstraZeneca 'vaccine'. The pictures were horrific. Leigh King, a 41-year-old hairdresser from Lanarkshire said: 'Never in my life was I prepared for what I was about to experience ... My skin was so sore and constantly hot ... I have never felt pain like this ...' But don't you worry, the 'vaccine' is perfectly safe. Then there has been the effect on medical



staff who have been pressured to have the 'vaccine' by psychopathic 'health' authorities and government. A London hospital consultant who gave the name K. Polyakova wrote this to the *British Medical Journal* or *BMJ*:

I am currently struggling with ... the failure to report the reality of the morbidity caused by our current vaccination program within the health service and staff population. The levels of sickness after vaccination is unprecedented and staff are getting very sick and some with neurological symptoms which is having a huge impact on the health service function. Even the young and healthy are off for days, some for weeks, and some requiring medical treatment. Whole teams are being taken out as they went to get vaccinated together.

Mandatory vaccination in this instance is stupid, unethical and irresponsible when it comes to protecting our staff and public health. We are in the voluntary phase of vaccination, and encouraging staff to take an unlicensed product that is impacting on their immediate health ... it is clearly stated that these vaccine products do not offer immunity or stop transmission. In which case why are we doing it?

Not to protect health that's for sure. Medical workers are lauded by governments for agenda reasons when they couldn't give a toss about them any more than they can for the population in general. Schools across America faced the same situation as they closed due to the high number of teachers and other staff with bad reactions to the Pfizer/BioNTech, Moderna, and Johnson & Johnson 'Covid vaccines' all of which were linked to death and serious adverse effects. The *BMJ* took down the consultant's comments pretty quickly on the grounds that they were being used to spread 'disinformation'. They were exposing the truth about the 'vaccine' was the real reason. The cover-up is breathtaking.

## **Hiding the evidence**

The scale of the 'vaccine' death cover-up worldwide can be confirmed by comparing official figures with the personal experience of the public. I heard of many people in my community who died immediately or soon after the vaccine that would never appear in the media or even likely on the official totals of 'vaccine' fatalities and adverse reactions when only about ten percent are estimated to be

reported and I have seen some estimates as low as one percent in a Harvard study. In the UK alone by April 29th, 2021, some 757,654 adverse reactions had been officially reported from the Pfizer/BioNTech, Oxford/AstraZeneca and Moderna 'vaccines' with more than a thousand deaths linked to jabs and that means an estimated ten times this number in reality from a ten percent reporting rate percentage. That's seven million adverse reactions and 10,000 potential deaths and a one percent reporting rate would be ten times *those* figures. In 1976 the US government pulled the swine flu vaccine after 53 deaths. The UK data included a combined 10,000 eye disorders from the 'Covid vaccines' with more than 750 suffering visual impairment or blindness and again multiply by the estimated reporting percentages. As 'Covid cases' officially fell hospitals virtually empty during the 'Covid crisis' began to fill up with a range of other problems in the wake of the 'vaccine' rollout. The numbers across America have also been catastrophic. Deaths linked to *all* types of vaccine increased by 6,000 percent in the first quarter of 2021 compared with 2020. A 39-year-old woman from Ogden, Utah, died four days after receiving a second dose of Moderna's 'Covid vaccine' when her liver, heart and kidneys all failed despite the fact that she had no known medical issues or conditions. Her family sought an autopsy, but Dr Erik Christensen, Utah's chief medical examiner, said proving vaccine injury as a cause of death almost never happened. He could think of only one instance where an autopsy would name a vaccine as the official cause of death and that would be anaphylaxis where someone received a vaccine and died almost instantaneously. 'Short of that, it would be difficult for us to definitively say this is the vaccine,' Christensen said. If that is true this must be added to the estimated ten percent (or far less) reporting rate of vaccine deaths and serious reactions and the conclusion can only be that vaccine deaths and serious reactions – including these 'Covid' potions' – are phenomenally understated in official figures. The same story can be found everywhere. Endless accounts of deaths and serious reactions among the public, medical

and care home staff while official figures did not even begin to reflect this.

Professional script-reader Dr David Williams, a 'top public-health official' in Ontario, Canada, insulted our intelligence by claiming only four serious adverse reactions and no deaths from the more than 380,000 vaccine doses then given. This bore no resemblance to what people knew had happened in their own circles and we had Dirk Huyer in charge of getting millions vaccinated in Ontario while at the same time he was Chief Coroner for the province investigating causes of death including possible death from the vaccine. An aide said he had stepped back from investigating deaths, but evidence indicated otherwise. Rosemary Frei, who secured a Master of Science degree in molecular biology at the Faculty of Medicine at Canada's University of Calgary before turning to investigative journalism, was one who could see that official figures for 'vaccine' deaths and reactions made no sense. She said that doctors seldom reported adverse events and when people got really sick or died after getting a vaccination they would attribute that to anything except the vaccines. It had been that way for years and anyone who wondered aloud whether the 'Covid vaccines' or other shots cause harm is immediately branded as 'anti-vax' and 'anti-science'. This was 'career-threatening' for health professionals. Then there was the huge pressure to support the push to 'vaccinate' billions in the quickest time possible. Frei said:

So that's where we're at today. More than half a million vaccine doses have been given to people in Ontario alone. The rush is on to vaccinate all 15 million of us in the province by September. And the mainstream media are screaming for this to be sped up even more. That all adds up to only a very slim likelihood that we're going to be told the truth by officials about how many people are getting sick or dying from the vaccines.

What is true of Ontario is true of everywhere.

### **They KNEW – and still did it**

The authorities knew what was going to happen with multiple deaths and adverse reactions. The UK government's Gates-funded

and Big Pharma-dominated Medicines and Healthcare products Regulatory Agency (MHRA) hired a company to employ AI in compiling the projected reactions to the 'vaccine' that would otherwise be uncountable. The request for applications said: 'The MHRA urgently seeks an Artificial Intelligence (AI) software tool to process the expected high volume of Covid-19 vaccine Adverse Drug Reaction ...' This was from the agency, headed by the disingenuous June Raine, that gave the 'vaccines' emergency approval and the company was hired before the first shot was given. 'We are going to kill and maim you – is that okay?' 'Oh, yes, perfectly fine – I'm very grateful, thank you, doctor.' The range of 'Covid vaccine' adverse reactions goes on for page after page in the MHRA criminally underreported 'Yellow Card' system and includes affects to eyes, ears, skin, digestion, blood and so on. Raine's MHRA amazingly claimed that the 'overall safety experience ... is so far as expected from the clinical trials'. The death, serious adverse effects, deafness and blindness were *expected*? When did they ever mention that? If these human tragedies were expected then those that gave approval for the use of these 'vaccines' must be guilty of crimes against humanity including murder – a definition of which is 'killing a person with malice aforethought or with recklessness manifesting extreme indifference to the value of human life.' People involved at the MHRA, the CDC in America and their equivalent around the world must go before Nuremberg trials to answer for their callous inhumanity. We are only talking here about the immediate effects of the 'vaccine'. The longer-term impact of the DNA synthetic manipulation is the main reason they are so hysterically desperate to inoculate the entire global population in the shortest possible time.

Africa and the developing world are a major focus for the 'vaccine' depopulation agenda and a mass vaccination sales-pitch is underway thanks to caring people like the Rockefellers and other Cult assets. The Rockefeller Foundation, which pre-empted the 'Covid pandemic' in a document published in 2010 that 'predicted' what happened a decade later, announced an initial \$34.95 million grant in February, 2021, 'to ensure more equitable access to Covid-19

testing and vaccines' among other things in Africa in collaboration with '24 organizations, businesses, and government agencies'. The pan-Africa initiative would focus on 10 countries: Burkina Faso, Ethiopia, Ghana, Kenya, Nigeria, Rwanda, South Africa, Tanzania, Uganda, and Zambia'. Rajiv Shah, President of the Rockefeller Foundation and former administrator of CIA-controlled USAID, said that if Africa was not mass-vaccinated (to change the DNA of its people) it was a 'threat to all of humanity' and not fair on Africans. When someone from the Rockefeller Foundation says they want to do something to help poor and deprived people and countries it is time for a belly-laugh. They are doing this out of the goodness of their 'heart' because 'vaccinating' the entire global population is what the 'Covid' hoax set out to achieve. Official 'decolonisation' of Africa by the Cult was merely a prelude to financial colonisation on the road to a return to physical colonisation. The 'vaccine' is vital to that and the sudden and convenient death of the 'Covid' sceptic president of Tanzania can be seen in its true light. A lot of people in Africa are aware that this is another form of colonisation and exploitation and they need to stand their ground.

### **The 'vaccine is working' scam**

A potential problem for the Cult was that the 'vaccine' is meant to change human DNA and body messaging and not to protect anyone from a 'virus' never shown to exist. The vaccine couldn't work because it was not designed to work and how could they make it *appear* to be working so that more people would have it? This was overcome by lowering the amplification rate of the PCR test to produce fewer 'cases' and therefore fewer 'deaths'. Some of us had been pointing out since March, 2020, that the amplification rate of the test not testing for the 'virus' had been made artificially high to generate positive tests which they could call 'cases' to justify lockdowns. The World Health Organization recommended an absurdly high 45 amplification cycles to ensure the high positives required by the Cult and then remained silent on the issue until January 20th, 2021 – Biden's Inauguration Day. This was when the

'vaccinations' were seriously underway and on that day the WHO recommended after discussions with America's CDC that laboratories *lowered their testing amplification*. Dr David Samadi, a certified urologist and health writer, said the WHO was encouraging all labs to reduce their cycle count for PCR tests. He said the current cycle was much too high and was 'resulting in any particle being declared a positive case'. Even one mainstream news report I saw said this meant the number of 'Covid' infections may have been 'dramatically inflated'. Oh, just a little bit. The CDC in America issued new guidance to laboratories in April, 2021, to use 28 cycles *but only for 'vaccinated' people*. The timing of the CDC/WHO interventions were cynically designed to make it appear the 'vaccines' were responsible for falling cases and deaths when the real reason can be seen in the following examples. New York's state lab, the Wadsworth Center, identified 872 positive tests in July, 2020, based on a threshold of 40 cycles. When the figure was lowered to 35 cycles 43 percent of the 872 were no longer 'positives'. At 30 cycles the figure was 63 percent. A Massachusetts lab found that between 85 to 90 percent of people who tested positive in July with a cycle threshold of 40 would be negative at 30 cycles, Ashish Jha, MD, director of the Harvard Global Health Institute, said: 'I'm really shocked that it could be that high ... Boy, does it really change the way we need to be thinking about testing.' I'm shocked that I could see the obvious in the spring of 2020, with no medical background, and most medical professionals still haven't worked it out. No, that's not shocking – it's terrifying.

Three weeks after the WHO directive to lower PCR cycles the London *Daily Mail* ran this headline: 'Why ARE Covid cases plummeting? New infections have fallen 45% in the US and 30% globally in the past 3 weeks but experts say vaccine is NOT the main driver because only 8% of Americans and 13% of people worldwide have received their first dose.' They acknowledged that the drop could not be attributed to the 'vaccine', but soon this morphed throughout the media into the 'vaccine' has caused cases and deaths to fall when it was the PCR threshold. In December, 2020, there was

chaos at English Channel ports with truck drivers needing negative 'Covid' tests before they could board a ferry home for Christmas. The government wanted to remove the backlog as fast as possible and they brought in troops to do the 'testing'. Out of 1,600 drivers just 36 tested positive and the rest were given the all clear to cross the Channel. I guess the authorities thought that 36 was the least they could get away with without the unquestioning catching on. The amplification trick which most people believed in the absence of information in the mainstream applied more pressure on those refusing the 'vaccine' to succumb when it 'obviously worked'. The truth was the exact opposite with deaths in care homes soaring with the 'vaccine' and in Israel the term used was 'skyrocket'. A re-analysis of published data from the Israeli Health Ministry led by Dr Hervé Seligmann at the Medicine Emerging Infectious and Tropical Diseases at Aix-Marseille University found that Pfizer's 'Covid vaccine' killed 'about 40 times more [elderly] people than the disease itself would have killed' during a five-week vaccination period and *260 times* more younger people than would have died from the 'virus' even according to the manipulated 'virus' figures. Dr Seligmann and his co-study author, Haim Yativ, declared after reviewing the Israeli 'vaccine' death data: 'This is a new Holocaust.'

Then, in mid-April, 2021, after vast numbers of people worldwide had been 'vaccinated', the story changed with clear coordination. The UK government began to prepare the ground for more future lockdowns when Nuremberg-destined Boris Johnson told yet another whopper. He said that cases had fallen because of *lockdowns* not 'vaccines'. Lockdowns are irrelevant when *there is no 'virus'* and the test and fraudulent death certificates are deciding the number of 'cases' and 'deaths'. Study after study has shown that lockdowns don't work and instead kill and psychologically destroy people. Meanwhile in the United States Anthony Fauci and Rochelle Walensky, the ultra-Zionist head of the CDC, peddled the same line. More lockdown was the answer and not the 'vaccine', a line repeated on cue by the moron that is Canadian Prime Minister Justin Trudeau. Why all the hysteria to get everyone 'vaccinated' if lockdowns and

not 'vaccines' made the difference? None of it makes sense on the face of it. Oh, but it does. The Cult wants lockdowns *and* the 'vaccine' and if the 'vaccine' is allowed to be seen as the total answer lockdowns would no longer be justified when there are still livelihoods to destroy. 'Variants' and renewed upward manipulation of PCR amplification are planned to instigate never-ending lockdown *and* more 'vaccines'.

### **You *must* have it – we're desperate**

Israel, where the Jewish and Arab population are ruled by the Sabbatian Cult, was the front-runner in imposing the DNA-manipulating 'vaccine' on its people to such an extent that Jewish refusers began to liken what was happening to the early years of Nazi Germany. This would seem to be a fantastic claim. Why would a government of Jewish people be acting like the Nazis did? If you realise that the Sabbatian Cult was behind the Nazis and that Sabbatians hate Jews the pieces start to fit and the question of why a 'Jewish' government would treat Jews with such callous disregard for their lives and freedom finds an answer. Those controlling the government of Israel *aren't Jewish* – they're Sabbatian. Israeli lawyer Tamir Turgal was one who made the Nazi comparison in comments to German lawyer Reiner Fuellmich who is leading a class action lawsuit against the psychopaths for crimes against humanity. Turgal described how the Israeli government was vaccinating children and pregnant women on the basis that there was no evidence that this was dangerous when they had no evidence that it *wasn't* dangerous either. They just had no evidence. This was medical experimentation and Turgal said this breached the Nuremberg Code about medical experimentation and procedures requiring informed consent and choice. Think about that. A Nuremberg Code developed because of Nazi experimentation on Jews and others in concentration camps by people like the evil-beyond-belief Josef Mengele is being breached by the *Israeli* government; but when you know that it's a *Sabbatian* government along with its intelligence and military agencies like Mossad, Shin Bet and the Israeli Defense Forces, and that Sabbatians



were the force behind the Nazis, the kaleidoscope comes into focus. What have we come to when Israeli Jews are suing their government for violating the Nuremberg Code by essentially making Israelis subject to a medical experiment using the controversial 'vaccines'? It's a shocker that this has to be done in the light of what happened in Nazi Germany. The Anshe Ha-Emet, or 'People of the Truth', made up of Israeli doctors, lawyers, campaigners and public, have launched a lawsuit with the International Criminal Court. It says:

When the heads of the Ministry of Health as well as the prime minister presented the vaccine in Israel and began the vaccination of Israeli residents, the vaccinated were not advised, that, in practice, they are taking part in a medical experiment and that their consent is required for this under the Nuremberg Code.

The irony is unbelievable, but easily explained in one word: Sabbatians. The foundation of Israeli 'Covid' apartheid is the 'green pass' or 'green passport' which allows Jews and Arabs who have had the DNA-manipulating 'vaccine' to go about their lives – to work, fly, travel in general, go to shopping malls, bars, restaurants, hotels, concerts, gyms, swimming pools, theatres and sports venues, while non-'vaccinated' are banned from all those places and activities. Israelis have likened the 'green pass' to the yellow stars that Jews in Nazi Germany were forced to wear – the same as the yellow stickers that a branch of UK supermarket chain Morrisons told exempt mask-wearers they had to display when shopping. How very sensitive. The Israeli system is blatant South African-style apartheid on the basis of compliance or non-compliance to fascism rather than colour of the skin. How appropriate that the Sabbatian Israeli government was so close to the pre-Mandela apartheid regime in Pretoria. The Sabbatian-instigated 'vaccine passport' in Israel is planned for everywhere. Sabbatians struck a deal with Pfizer that allowed them to lead the way in the percentage of a national population infused with synthetic material and the result was catastrophic. Israeli freedom activist Shai Dannon told me how chairs were appearing on beaches that said 'vaccinated only'. Health Minister Yuli Edelstein said that anyone unwilling or unable to get

the jabs that 'confer immunity' will be 'left behind'. The man's a liar. Not even the makers claim the 'vaccines' confer immunity. When you see those figures of 'vaccine' deaths these psychopaths were saying that you must take the chance the 'vaccine' will kill you or maim you while knowing it will change your DNA or lockdown for you will be permanent. That's fascism. The Israeli parliament passed a law to allow personal information of the non-vaccinated to be shared with local and national authorities for three months. This was claimed by its supporters to be a way to 'encourage' people to be vaccinated. Hadas Ziv from Physicians for Human Rights described this as a 'draconian law which crushed medical ethics and the patient rights'. But that's the idea, the Sabbatians would reply.

### **Your papers, please**

Sabbatian Israel was leading what has been planned all along to be a global 'vaccine pass' called a 'green passport' without which you would remain in permanent lockdown restriction and unable to do anything. This is how badly – *desperately* – the Cult is to get everyone 'vaccinated'. The term and colour 'green' was not by chance and related to the psychology of fusing the perception of the green climate hoax with the 'Covid' hoax and how the 'solution' to both is the same Great Reset. Lying politicians, health officials and psychologists denied there were any plans for mandatory vaccinations or restrictions based on vaccinations, but they knew that was exactly what was meant to happen with governments of all countries reaching agreements to enforce a global system. 'Free' Denmark and 'free' Sweden unveiled digital vaccine certification. Cyprus, Czech Republic, Estonia, Greece, Hungary, Iceland, Italy, Poland, Portugal, Slovakia, and Spain have all committed to a vaccine passport system and the rest including the whole of the EU would follow. The satanic UK government will certainly go this way despite mendacious denials and at the time of writing it is trying to manipulate the public into having the 'vaccine' so they could go abroad on a summer holiday. How would that work without something to prove you had the synthetic toxicity injected into you?

Documents show that the EU's European Commission was moving towards 'vaccine certificates' in 2018 and 2019 before the 'Covid' hoax began. They knew what was coming. Abracadabra – Ursula von der Leyen, the German President of the Commission, announced in March, 2021, an EU 'Digital Green Certificate' – green again – to track the public's 'Covid status'. The passport sting is worldwide and the Far East followed the same pattern with South Korea ruling that only those with 'vaccination' passports – again the *green* pass – would be able to 'return to their daily lives'.

Bill Gates has been preparing for this 'passport' with other Cult operatives for years and beyond the paper version is a Gates-funded 'digital tattoo' to identify who has been vaccinated and who hasn't. The 'tattoo' is reported to include a substance which is externally readable to confirm who has been vaccinated. This is a bio-luminous light-generating enzyme (think fireflies) called ... *Luciferase*. Yes, named after the Cult 'god' Lucifer the 'light bringer' of whom more to come. Gates said he funded the readable tattoo to ensure children in the developing world were vaccinated and no one was missed out. He cares so much about poor kids as we know. This was just the cover story to develop a vaccine tagging system for everyone on the planet. Gates has been funding the ID2020 'alliance' to do just that in league with other lovely people at Microsoft, GAVI, the Rockefeller Foundation, Accenture and IDEO.org. He said in interviews in March, 2020, before any 'vaccine' publicly existed, that the world must have a globalised digital certificate to track the 'virus' and who had been vaccinated. Gates knew from the start that the mRNA vaccines were coming and when they would come and that the plan was to tag the 'vaccinated' to marginalise the intelligent and stop them doing anything including travel. Evil just doesn't suffice. Gates was exposed for offering a \$10 million bribe to the Nigerian House of Representatives to invoke compulsory 'Covid' vaccination of all Nigerians. Sara Cunial, a member of the Italian Parliament, called Gates a 'vaccine criminal'. She urged the Italian President to hand him over to the International Criminal Court for crimes against

humanity and condemned his plans to 'chip the human race' through ID2020.

You know it's a long-planned agenda when war criminal and Cult gofer Tony Blair is on the case. With the scale of arrogance only someone as dark as Blair can muster he said: 'Vaccination in the end is going to be your route to liberty.' Blair is a disgusting piece of work and he confirms that again. The media has given a lot of coverage to a bloke called Charlie Mullins, founder of London's biggest independent plumbing company, Pimlico Plumbers, who has said he won't employ anyone who has not been vaccinated or have them go to any home where people are not vaccinated. He said that if he had his way no one would be allowed to walk the streets if they have not been vaccinated. Gates was cheering at the time while I was alerting the white coats. The plan is that people will qualify for 'passports' for having the first two doses and then to keep it they will have to have all the follow ups and new ones for invented 'variants' until human genetics is transformed and many are dead who can't adjust to the changes. Hollywood celebrities – the usual propaganda stunt – are promoting something called the WELL Health-Safety Rating to verify that a building or space has 'taken the necessary steps to prioritize the health and safety of their staff, visitors and other stakeholders'. They included Lady Gaga, Jennifer Lopez, Michael B. Jordan, Robert DeNiro, Venus Williams, Wolfgang Puck, Deepak Chopra and 17th Surgeon General Richard Carmona. Yawn. WELL Health-Safety has big connections with China. Parent company Delos is headed by former Goldman Sachs partner Paul Scialla. This is another example – and we will see so many others – of using the excuse of 'health' to dictate the lives and activities of the population. I guess one confirmation of the 'safety' of buildings is that only 'vaccinated' people can go in, right?

## **Electronic concentration camps**

I wrote decades ago about the plans to restrict travel and here we are for those who refuse to bow to tyranny. This can be achieved in one go with air travel if the aviation industry makes a blanket decree.

The 'vaccine' and guaranteed income are designed to be part of a global version of China's social credit system which tracks behaviour 24/7 and awards or deletes 'credits' based on whether your behaviour is supported by the state or not. I mean your entire lifestyle – what you do, eat, say, everything. Once your credit score falls below a certain level consequences kick in. In China tens of millions have been denied travel by air and train because of this. All the locations and activities denied to refusers by the 'vaccine' passports will be included in one big mass ban on doing almost anything for those that don't bow their head to government. It's beyond fascist and a new term is required to describe its extremes – I guess fascist technocracy will have to do. The way the Chinese system of technological – technocratic – control is sweeping the West can be seen in the Los Angeles school system and is planned to be expanded worldwide. Every child is required to have a 'Covid'-tracking app scanned daily before they can enter the classroom. The so-called Daily Pass tracking system is produced by Gates' Microsoft which I'm sure will shock you rigid. The pass will be scanned using a barcode (one step from an inside-the-body barcode) and the information will include health checks, 'Covid' tests and vaccinations. Entry codes are for one specific building only and access will only be allowed if a student or teacher has a negative test with a test not testing for the 'virus', has no symptoms of anything alleged to be related to 'Covid' (symptoms from a range of other illness), and has a temperature under 100 degrees. No barcode, no entry, is planned to be the case for everywhere and not only schools.

Kids are being psychologically prepared to accept this as 'normal' their whole life which is why what they can impose in schools is so important to the Cult and its gofers. Long-time American freedom campaigner John Whitehead of the Rutherford Institute was not exaggerating when he said: 'Databit by databit, we are building our own electronic concentration camps.' Canada under its Cult gofer prime minister Justin Trudeau has taken a major step towards the real thing with people interned against their will if they test positive with a test not testing for the 'virus' when they arrive at a Canadian

airport. They are jailed in internment hotels often without food or water for long periods and with many doors failing to lock there have been sexual assaults. The interned are being charged sometimes \$2,000 for the privilege of being abused in this way. Trudeau is fully on board with the Cult and says the 'Covid pandemic' has provided an opportunity for a global 'reset' to permanently change Western civilisation. His number two, Deputy Prime Minister Chrystia Freeland, is a trustee of the World Economic Forum and a Rhodes Scholar. The Trudeau family have long been servants of the Cult. See *The Biggest Secret* and Cathy O'Brien's book *Trance-Formation of America* for the horrific background to Trudeau's father Pierre Trudeau another Canadian prime minister. Hide your fascism behind the façade of a heart-on-the-sleeve liberal. It's a well-honed Cult technique.

### **What can the 'vaccine' really do?**

We have a 'virus' never shown to exist and 'variants' of the 'virus' that have also never been shown to exist except, like the 'original', as computer-generated fictions. Even if you believe there's a 'virus' the 'case' to 'death' rate is in the region of 0.23 to 0.15 percent and those 'deaths' are concentrated among the very old around the same average age that people die anyway. In response to this lack of threat (in truth none) psychopaths and idiots, knowingly and unknowingly answering to Gates and the Cult, are seeking to 'vaccinate' every man, woman and child on Planet Earth. Clearly the 'vaccine' is not about 'Covid' – none of this ever has been. So what is it all about *really*? Why the desperation to infuse genetically-manipulating synthetic material into everyone through mRNA fraudulent 'vaccines' with the intent of doing this over and over with the excuses of 'variants' and other 'virus' inventions? Dr Sherri Tenpenny, an osteopathic medical doctor in the United States, has made herself an expert on vaccines and their effects as a vehement campaigner against their use. Tenpenny was board certified in emergency medicine, the director of a level two trauma centre for 12 years, and moved to Cleveland in 1996 to start an integrative

medicine practice which has treated patients from all 50 states and some 17 other countries. Weaning people off pharmaceutical drugs is a speciality.

She became interested in the consequences of vaccines after attending a meeting at the National Vaccine Information Center in Washington DC in 2000 where she 'sat through four days of listening to medical doctors and scientists and lawyers and parents of vaccine injured kids' and asked: 'What's going on?' She had never been vaccinated and never got ill while her father was given a list of vaccines to be in the military and was 'sick his entire life'. The experience added to her questions and she began to examine vaccine documents from the Centers for Disease Control (CDC). After reading the first one, the 1998 version of *The General Recommendations of Vaccination*, she thought: 'This is it?' The document was poorly written and bad science and Tenpenny began 20 years of research into vaccines that continues to this day. She began her research into 'Covid vaccines' in March, 2020, and she describes them as 'deadly'. For many, as we have seen, they already have been. Tenpenny said that in the first 30 days of the 'vaccine' rollout in the United States there had been more than 40,000 adverse events reported to the vaccine adverse event database. A document had been delivered to her the day before that was 172 pages long. 'We have over 40,000 adverse events; we have over 3,100 cases of [potentially deadly] anaphylactic shock; we have over 5,000 neurological reactions.' Effects ranged from headaches to numbness, dizziness and vertigo, to losing feeling in hands or feet and paraesthesia which is when limbs 'fall asleep' and people have the sensation of insects crawling underneath their skin. All this happened in the first 30 days and remember that only about *ten percent* (or far less) of adverse reactions and vaccine-related deaths are estimated to be officially reported. Tenpenny said:

So can you think of one single product in any industry, any industry, for as long as products have been made on the planet that within 30 days we have 40,000 people complaining of side effects that not only is still on the market but ... we've got paid actors telling us how great

they are for getting their vaccine. We're offering people \$500 if they will just get their vaccine and we've got nurses and doctors going; 'I got the vaccine, I got the vaccine'.

Tenpenny said they were not going to be 'happy dancing folks' when they began to suffer Bell's palsy (facial paralysis), neuropathies, cardiac arrhythmias and autoimmune reactions that kill through a blood disorder. 'They're not going to be so happy, happy then, but we're never going to see pictures of those people' she said. Tenpenny described the 'vaccine' as 'a well-designed killing tool'.

## **No off-switch**

Bad as the initial consequences had been Tenpenny said it would be maybe 14 months before we began to see the 'full ravage' of what is going to happen to the 'Covid vaccinated' with full-out consequences taking anything between two years and 20 years to show. You can understand why when you consider that variations of the 'Covid vaccine' use mRNA (messenger RNA) to in theory activate the immune system to produce protective antibodies without using the actual 'virus'. How can they when it's a computer program and they've never isolated what they claim is the 'real thing'? Instead they use *synthetic* mRNA. They are inoculating synthetic material into the body which through a technique known as the Trojan horse is absorbed into cells to change the nature of DNA. Human DNA is changed by an infusion of messenger RNA and with each new 'vaccine' of this type it is changed even more. Say so and you are banned by Cult Internet platforms. The contempt the contemptuous Mark Zuckerberg has for the truth and human health can be seen in an internal Facebook video leaked to the Project Veritas investigative team in which he said of the 'Covid vaccines': '... I share some caution on this because we just don't know the long term side-effects of basically modifying people's DNA and RNA.' At the same time this disgusting man's Facebook was censoring and banning anyone saying exactly the same. He must go before a Nuremberg trial for crimes against humanity when he *knows* that he



is censoring legitimate concerns and denying the right of informed consent on behalf of the Cult that owns him. People have been killed and damaged by the very 'vaccination' technique he cast doubt on himself when they may not have had the 'vaccine' with access to information that he denied them. The plan is to have at least annual 'Covid vaccinations', add others to deal with invented 'variants', and change all other vaccines into the mRNA system. Pfizer executives told shareholders at a virtual Barclays Global Healthcare Conference in March, 2021, that the public may need a third dose of 'Covid vaccine', plus regular yearly boosters and the company planned to hike prices to milk the profits in a 'significant opportunity for our vaccine'. These are the professional liars, cheats and opportunists who are telling you their 'vaccine' is safe. Given this volume of mRNA planned to be infused into the human body and its ability to then replicate we will have a transformation of human genetics from biological to synthetic biological – exactly the long-time Cult plan for reasons we'll see – and many will die. Sherri Tenpenny said of this replication:

It's like having an on-button but no off-button and that whole mechanism ... they actually give it a name and they call it the Trojan horse mechanism, because it allows that [synthetic] virus and that piece of that [synthetic] virus to get inside of your cells, start to replicate and even get inserted into other parts of your DNA as a Trojan-horse.

Ask the overwhelming majority of people who have the 'vaccine' what they know about the contents and what they do and they would reply: 'The government says it will stop me getting the virus.' Governments give that false impression on purpose to increase take-up. You can read Sherri Tenpenny's detailed analysis of the health consequences in her blog at [Vaxxter.com](https://www.vaxxter.com), but in summary these are some of them. She highlights the statement by Bill Gates about how human beings can become their own 'vaccine manufacturing machine'. The man is insane. ['Vaccine'-generated] 'antibodies' carry synthetic messenger RNA into the cells and the damage starts, Tenpenny contends, and she says that lungs can be adversely affected through varying degrees of pus and bleeding which

obviously affects breathing and would be dubbed 'Covid-19'. Even more sinister was the impact of 'antibodies' on macrophages, a white blood cell of the immune system. They consist of Type 1 and Type 2 which have very different functions. She said Type 1 are 'hyper-vigilant' white blood cells which 'gobble up' bacteria etc. However, in doing so, this could cause inflammation and in extreme circumstances be fatal. She says these affects are mitigated by Type 2 macrophages which kick in to calm down the system and stop it going rogue. They clear up dead tissue debris and reduce inflammation that the Type 1 'fire crews' have caused. Type 1 kills the infection and Type 2 heals the damage, she says. This is her punchline with regard to 'Covid vaccinations': She says that mRNA 'antibodies' block Type 2 macrophages by attaching to them and deactivating them. This meant that when the Type 1 response was triggered by infection there was nothing to stop that getting out of hand by calming everything down. There's an on-switch, but no off-switch, she says. What follows can be 'over and out, see you when I see you'.

## **Genetic suicide**

Tenpenny also highlights the potential for autoimmune disease – the body attacking itself – which has been associated with vaccines since they first appeared. Infusing a synthetic foreign substance into cells could cause the immune system to react in a panic believing that the body is being overwhelmed by an invader (it is) and the consequences can again be fatal. There is an autoimmune response known as a 'cytokine storm' which I have likened to a homeowner panicked by an intruder and picking up a gun to shoot randomly in all directions before turning the fire on himself. The immune system unleashes a storm of inflammatory response called cytokines to a threat and the body commits hara-kiri. The lesson is that you mess with the body's immune response at your peril and these 'vaccines' seriously – fundamentally – mess with immune response. Tenpenny refers to a consequence called anaphylactic shock which is a severe and highly dangerous allergic reaction when the immune system

floods the body with chemicals. She gives the example of having a bee sting which primes the immune system and makes it sensitive to those chemicals. When people are stung again maybe years later the immune response can be so powerful that it leads to anaphylactic shock. Tenpenny relates this 'shock' with regard to the 'Covid vaccine' to something called polyethylene glycol or PEG. Enormous numbers of people have become sensitive to this over decades of use in a whole range of products and processes including food, drink, skin creams and 'medicine'. Studies have claimed that some 72 percent of people have antibodies triggered by PEG compared with two percent in the 1960s and allergic hypersensitive reactions to this become a gathering cause for concern. Tenpenny points out that the 'mRNA vaccine' is coated in a 'bubble' of polyethylene glycol which has the potential to cause anaphylactic shock through immune sensitivity. Many reports have appeared of people reacting this way after having the 'Covid vaccine'. What do we think is going to happen as humanity has more and more of these 'vaccines'?

Tenpenny said: 'All these pictures we have seen with people with these rashes ... these weepy rashes, big reactions on their arms and things like that – it's an acute allergic reaction most likely to the polyethylene glycol that you've been previously primed and sensitised to.'

Those who have not studied the conspiracy and its perpetrators at length might think that making the population sensitive to PEG and then putting it in these 'vaccines' is just a coincidence. It is not. It is instead testament to how carefully and coldly-planned current events have been and the scale of the conspiracy we are dealing with. Tenpenny further explains that the 'vaccine' mRNA procedure can breach the blood-brain barrier which protects the brain from toxins and other crap that will cause malfunction. In this case they could make two proteins corrupt brain function to cause Amyotrophic lateral sclerosis (ALS), a progressive nervous system disease leading to loss of muscle control, and frontal lobe degeneration – Alzheimer's and dementia. Immunologist J. Bart Classon published a paper connecting mRNA 'vaccines' to prion

disease which can lead to Alzheimer's and other forms of neurodegenerative disease while others have pointed out the potential to affect the placenta in ways that make women infertile. This will become highly significant in the next chapter when I will discuss other aspects of this non-vaccine that relate to its nanotechnology and transmission from the injected to the uninjected.

## **Qualified in idiocy**

Tenpenny describes how research has confirmed that these 'vaccine'-generated antibodies can interact with a range of other tissues in the body and attack many other organs including the lungs. 'This means that if you have a hundred people standing in front of you that all got this shot they could have a hundred different symptoms.'

Anyone really think that Cult gofers like the Queen, Tony Blair, Christopher Whitty, Anthony Fauci, and all the other psychopaths have really had this 'vaccine' in the pictures we've seen? Not a bloody chance. Why don't doctors all tell us about all these dangers and consequences of the 'Covid vaccine'? Why instead do they encourage and pressure patients to have the shot? Don't let's think for a moment that doctors and medical staff can't be stupid, lazy, and psychopathic and that's without the financial incentives to give the jab. Tenpenny again:

Some people are going to die from the vaccine directly but a large number of people are going to start to get horribly sick and get all kinds of autoimmune diseases 42 days to maybe a year out. What are they going to do, these stupid doctors who say; 'Good for you for getting that vaccine.' What are they going to say; 'Oh, it must be a mutant, we need to give an extra dose of that vaccine.'

Because now the vaccine, instead of one dose or two doses we need three or four because the stupid physicians aren't taking the time to learn anything about it. If I can learn this sitting in my living room reading a 19 page paper and several others so can they. There's nothing special about me, I just take the time to do it.

Remember how Sara Kayat, the NHS and TV doctor, said that the 'Covid vaccine' would '100 percent prevent hospitalisation and death'. Doctors can be idiots like every other profession and they

should not be worshipped as infallible. They are not and far from it. Behind many medical and scientific 'experts' lies an uninformed prat trying to hide themselves from you although in the 'Covid' era many have failed to do so as with UK narrative-repeating 'TV doctor' Hilary Jones. Pushing back against the minority of proper doctors and scientists speaking out against the 'vaccine' has been the entire edifice of the Cult global state in the form of governments, medical systems, corporations, mainstream media, Silicon Valley, and an army of compliant doctors, medical staff and scientists willing to say anything for money and to enhance their careers by promoting the party line. If you do that you are an 'expert' and if you won't you are an 'anti-vaxxer' and 'Covidiot'. The pressure to be 'vaccinated' is incessant. We have even had reports claiming that the 'vaccine' can help cure cancer and Alzheimer's and make the lame walk. I am waiting for the announcement that it can bring you coffee in the morning and cook your tea. Just as the symptoms of 'Covid' seem to increase by the week so have the miracles of the 'vaccine'. American supermarket giant Kroger Co. offered nearly 500,000 employees in 35 states a \$100 bonus for having the 'vaccine' while donut chain Krispy Kreme promised 'vaccinated' customers a free glazed donut every day for the rest of 2021. Have your DNA changed and you will get a doughnut although we might not have to give you them for long. Such offers and incentives confirm the desperation.

Perhaps the worse vaccine-stunt of them all was UK 'Health' Secretary Matt-the-prat Hancock on live TV after watching a clip of someone being 'vaccinated' when the roll-out began. Hancock faked tears so badly it was embarrassing. Brain-of-Britain Piers Morgan, the lockdown-supporting, 'vaccine' supporting, 'vaccine' passport-supporting, TV host played along with Hancock – 'You're quite emotional about that' he said in response to acting so atrocious it would have been called out at a school nativity which will presumably today include Mary and Jesus in masks, wise men keeping their camels six feet apart, and shepherds under tent arrest. System-serving Morgan tweeted this: 'Love the idea of covid vaccine passports for everywhere: flights, restaurants, clubs, football, gyms,

shops etc. It's time covid-denying, anti-vaxxer loonies had their bullsh\*t bluff called & bar themselves from going anywhere that responsible citizens go.' If only I could aspire to his genius. To think that Morgan, who specialises in shouting over anyone he disagrees with, was lauded as a free speech hero when he lost his job after storming off the set of his live show like a child throwing his dolly out of the pram. If he is a free speech hero we are in real trouble. I have no idea what 'bullsh\*t' means, by the way, the \* throws me completely.

The Cult is desperate to infuse its synthetic DNA-changing concoction into everyone and has been using every lie, trick and intimidation to do so. The question of '*Why?*' we shall now address.

## CHAPTER TEN

### Human 2.0

*I believe that at the end of the century the use of words and general educated opinion will have altered so much that one will be able to speak of machines thinking without expecting to be contradicted –*  
Alan Turing (1912-1954), the ‘Father of artificial intelligence’

I have been exposing for decades the plan to transform the human body from a biological to a synthetic-biological state. The new human that I will call Human 2.0 is planned to be connected to artificial intelligence and a global AI ‘Smart Grid’ that would operate as one global system in which AI would control everything from your fridge to your heating system to your car to your mind. Humans would no longer be ‘human’, but post-human and sub-human, with their thinking and emotional processes replaced by AI.

What I said sounded crazy and beyond science fiction and I could understand that. To any balanced, rational, mind it *is* crazy. Today, however, that world is becoming reality and it puts the ‘Covid vaccine’ into its true context. Ray Kurzweil is the ultra-Zionist ‘computer scientist, inventor and futurist’ and co-founder of the Singularity University. Singularity refers to the merging of humans with machines or ‘transhumanism’. Kurzweil has said humanity would be connected to the cyber ‘cloud’ in the period of the ever-recurring year of 2030:

Our thinking ... will be a hybrid of biological and non-biological thinking ... humans will be able to extend their limitations and ‘think in the cloud’ ... We’re going to put gateways to the

cloud in our brains ... We're going to gradually merge and enhance ourselves ... In my view, that's the nature of being human – we transcend our limitations. As the technology becomes vastly superior to what we are then the small proportion that is still human gets smaller and smaller and smaller until it's just utterly negligible.

They are trying to sell this end-of-humanity-as-we-know-it as the next stage of 'evolution' when we become super-human and 'like the gods'. They are lying to you. Shocked, eh? The population, and again especially the young, have been manipulated into addiction to technologies designed to enslave them for life. First they induced an addiction to smartphones (holdables); next they moved to technology on the body (wearables); and then began the invasion of the body (implantables). I warned way back about the plan for microchipped people and we are now entering that era. We should not be diverted into thinking that this refers only to chips we can see. Most important are the nanochips known as smart dust, neural dust and nanobots which are far too small to be seen by the human eye. Nanotechnology is everywhere, increasingly in food products, and released into the atmosphere by the geoengineering of the skies funded by Bill Gates to 'shut out the Sun' and 'save the planet from global warming'. Gates has been funding a project to spray millions of tonnes of chalk (calcium carbonate) into the stratosphere over Sweden to 'dim the Sun' and cool the Earth. Scientists warned the move could be disastrous for weather systems in ways no one can predict and opposition led to the Swedish space agency announcing that the 'experiment' would not be happening as planned in the summer of 2021; but it shows where the Cult is going with dimming the impact of the Sun and there's an associated plan to change the planet's atmosphere. Who gives psychopath Gates the right to dictate to the entire human race and dismantle planetary systems? The world will not be safe while this man is at large.

The global warming hoax has made the Sun, like the gas of life, something to fear when both are essential to good health and human survival (more inversion). The body transforms sunlight into vital vitamin D through a process involving ... *cholesterol*. This is the cholesterol we are also told to fear. We are urged to take Big Pharma



statin drugs to reduce cholesterol and it's all systematic. Reducing cholesterol means reducing vitamin D uptake with all the multiple health problems that will cause. At least if you take statins long term it saves the government from having to pay you a pension. The delivery system to block sunlight is widely referred to as chemtrails although these have a much deeper agenda, too. They appear at first to be contrails or condensation trails streaming from aircraft into cold air at high altitudes. Contrails disperse very quickly while chemtrails do not and spread out across the sky before eventually their content falls to earth. Many times I have watched aircraft cross-cross a clear blue sky releasing chemtrails until it looks like a cloudy day. Chemtrails contain many things harmful to humans and the natural world including toxic heavy metals, aluminium (see Alzheimer's) and nanotechnology. Ray Kurzweil reveals the reason without actually saying so: 'Nanobots will infuse all the matter around us with information. Rocks, trees, everything will become these intelligent creatures.' How do you deliver that? *From the sky.* Self-replicating nanobots would connect everything to the Smart Grid. The phenomenon of Morgellons disease began in the chemtrail era and the correlation has led to it being dubbed the 'chemtrail disease'. Self-replicating fibres appear in the body that can be pulled out through the skin. Morgellons fibres continue to grow outside the body and have a form of artificial intelligence. I cover this at greater length in *Phantom Self*.

### **'Vaccine' operating system**

'Covid vaccines' with their self-replicating synthetic material are also designed to make the connection between humanity and Kurzweil's 'cloud'. American doctor and dedicated campaigner for truth, Carrie Madej, an Internal Medicine Specialist in Georgia with more than 20 years medical experience, has highlighted the nanotechnology aspect of the fake 'vaccines'. She explains how one of the components in at least the Moderna and Pfizer synthetic potions are 'lipid nanoparticles' which are 'like little tiny computer bits' – a 'sci-fi substance' known as nanobots and hydrogel which can be 'triggered

at any moment to deliver its payload' and act as 'biosensors'. The synthetic substance had 'the ability to accumulate data from your body like your breathing, your respiration, thoughts and emotions, all kind of things' and each syringe could carry a *million* nanobots:

This substance because it's like little bits of computers in your body, crazy, but it's true, it can do that, [and] obviously has the ability to act through Wi-Fi. It can receive and transmit energy, messages, frequencies or impulses. That issue has never been addressed by these companies. What does that do to the human?

Just imagine getting this substance in you and it can react to things all around you, the 5G, your smart device, your phones, what is happening with that? What if something is triggering it, too, like an impulse, a frequency? We have something completely foreign in the human body.

Madej said her research revealed that electromagnetic (EMF) frequencies emitted by phones and other devices had increased dramatically in the same period of the 'vaccine' rollout and she was seeing more people with radiation problems as 5G and other electromagnetic technology was expanded and introduced to schools and hospitals. She said she was 'floored with the EMF coming off' the devices she checked. All this makes total sense and syncs with my own work of decades when you think that Moderna refers in documents to its mRNA 'vaccine' as an 'operating system':

Recognizing the broad potential of mRNA science, we set out to create an mRNA technology platform that functions very much like an operating system on a computer. It is designed so that it can plug and play interchangeably with different programs. In our case, the 'program' or 'app' is our mRNA drug – the unique mRNA sequence that codes for a protein ...

... Our MRNA Medicines – 'The 'Software Of Life': When we have a concept for a new mRNA medicine and begin research, fundamental components are already in place. Generally, the only thing that changes from one potential mRNA medicine to another is the coding region – the actual genetic code that instructs ribosomes to make protein. Utilizing these instruction sets gives our investigational mRNA medicines a software-like quality. We also have the ability to combine different mRNA sequences encoding for different proteins in a single mRNA investigational medicine.

Who needs a real 'virus' when you can create a computer version to justify infusing your operating system into the entire human race on the road to making living, breathing people into cyborgs? What is missed with the 'vaccines' is the *digital* connection between synthetic material and the body that I highlighted earlier with the study that hacked a computer with human DNA. On one level the body is digital, based on mathematical codes, and I'll have more about that in the next chapter. Those who ridiculously claim that mRNA 'vaccines' are not designed to change human genetics should explain the words of Dr Tal Zaks, chief medical officer at Moderna, in a 2017 TED talk. He said that over the last 30 years 'we've been living this phenomenal digital scientific revolution, and I'm here today to tell you, that we are actually *hacking the software of life*, and that it's changing the way we think about prevention and treatment of disease':

In every cell there's this thing called messenger RNA, or mRNA for short, that transmits the critical information from the DNA in our genes to the protein, which is really the stuff we're all made out of. This is the critical information that determines what the cell will do. So we think about it as an operating system. So if you could change that, if you could introduce a line of code, or change a line of code, it turns out, that has profound implications for everything, from the flu to cancer.

Zaks should more accurately have said that this has profound implications for the human genetic code and the nature of DNA. Communications within the body go both ways and not only one. But, hey, no, the 'Covid vaccine' will not affect your genetics. Cult fact-checkers say so even though the man who helped to develop the mRNA technique says that it does. Zaks said in 2017:

If you think about what it is we're trying to do. We've taken information and our understanding of that information and how that information is transmitted in a cell, and we've taken our understanding of medicine and how to make drugs, and we're fusing the two. We think of it as information therapy.

I have been writing for decades that the body is an information field communicating with itself and the wider world. This is why

radiation which is information can change the information field of body and mind through phenomena like 5G and change their nature and function. 'Information therapy' means to change the body's information field and change the way it operates. DNA is a receiver-transmitter of information and can be mutated by information like mRNA synthetic messaging. Technology to do this has been ready and waiting in the underground bases and other secret projects to be rolled out when the 'Covid' hoax was played. 'Trials' of such short and irrelevant duration were only for public consumption. When they say the 'vaccine' is 'experimental' that is not true. It may appear to be 'experimental' to those who don't know what's going on, but the trials have already been done to ensure the Cult gets the result it desires. Zaks said that it took decades to sequence the human genome, completed in 2003, but now they could do it in a week. By 'they' he means scientists operating in the public domain. In the secret projects they were sequencing the genome in a week long before even 2003.

## **Deluge of mRNA**

Highly significantly the Moderna document says the guiding premise is that if using mRNA as a medicine works for one disease then it should work for many diseases. They were leveraging the flexibility afforded by their platform and the fundamental role mRNA plays in protein synthesis to pursue mRNA medicines for a broad spectrum of diseases. Moderna is confirming what I was saying through 2020 that multiple 'vaccines' were planned for 'Covid' (and later invented 'variants') and that previous vaccines would be converted to the mRNA system to infuse the body with massive amounts of genetically-manipulating synthetic material to secure a transformation to a synthetic-biological state. The 'vaccines' are designed to kill stunning numbers as part of the long-exposed Cult depopulation agenda and transform the rest. Given this is the goal you can appreciate why there is such hysterical demand for every human to be 'vaccinated' for an alleged 'disease' that has an estimated 'infection' to 'death' ratio of 0.23-0.15 percent. As I write

children are being given the 'vaccine' in trials (their parents are a disgrace) and ever-younger people are being offered the vaccine for a 'virus' that even if you believe it exists has virtually zero chance of harming them. Horrific effects of the 'trials' on a 12-year-old girl were revealed by a family member to be serious brain and gastric problems that included a bowel obstruction and the inability to swallow liquids or solids. She was unable to eat or drink without throwing up, had extreme pain in her back, neck and abdomen, and was paralysed from the waist down which stopped her urinating unaided. When the girl was first taken to hospital doctors said it was all in her mind. She was signed up for the 'trial' by her parents for whom no words suffice. None of this 'Covid vaccine' insanity makes any sense unless you see what the 'vaccine' really is – a body-changer. Synthetic biology or 'SynBio' is a fast-emerging and expanding scientific discipline which includes everything from genetic and molecular engineering to electrical and computer engineering. Synthetic biology is defined in these ways:

- A multidisciplinary area of research that seeks to create new biological parts, devices, and systems, or to redesign systems that are already found in nature.
- The use of a mixture of physical engineering and genetic engineering to create new (and therefore synthetic) life forms.
- An emerging field of research that aims to combine the knowledge and methods of biology, engineering and related disciplines in the design of chemically-synthesized DNA to create organisms with novel or enhanced characteristics and traits (synthetic organisms including humans).

We now have synthetic blood, skin, organs and limbs being developed along with synthetic body parts produced by 3D printers. These are all elements of the synthetic human programme and this comment by Kurzweil's co-founder of the Singularity University,

Peter Diamandis, can be seen in a whole new light with the 'Covid' hoax and the sanctions against those that refuse the 'vaccine':

Anybody who is going to be resisting the progress forward [to transhumanism] is going to be resisting evolution and, fundamentally, they will die out. It's not a matter of whether it's good or bad. It's going to happen.

'Resisting evolution'? What absolute bollocks. The arrogance of these people is without limit. His 'it's going to happen' mantra is another way of saying 'resistance is futile' to break the spirit of those pushing back and we must not fall for it. Getting this genetically-transforming 'vaccine' into everyone is crucial to the Cult plan for total control and the desperation to achieve that is clear for anyone to see. Vaccine passports are a major factor in this and they, too, are a form of resistance is futile. It's NOT. The paper funded by the Rockefeller Foundation for the 2013 'health conference' in China said:

We will interact more with artificial intelligence. The use of robotics, bio-engineering to augment human functioning is already well underway and will advance. Re-engineering of humans into potentially separate and unequal forms through genetic engineering or mixed human-robots raises debates on ethics and equality.

A new demography is projected to emerge after 2030 [that year again] of technologies (robotics, genetic engineering, nanotechnology) producing robots, engineered organisms, 'nanobots' and artificial intelligence (AI) that can self-replicate. Debates will grow on the implications of an impending reality of human designed life.

What is happening today is so long planned. The world army enforcing the will of the world government is intended to be a robot army, not a human one. Today's military and its technologically 'enhanced' troops, pilotless planes and driverless vehicles are just stepping stones to that end. Human soldiers are used as Cult fodder and its time they woke up to that and worked for the freedom of the population instead of their own destruction and their family's destruction – the same with the police. Join us and let's sort this out. The phenomenon of enforce my own destruction is widespread in the 'Covid' era with Woker 'luvvies' in the acting and entertainment

industries supporting 'Covid' rules which have destroyed their profession and the same with those among the public who put signs on the doors of their businesses 'closed due to Covid – stay safe' when many will never reopen. It's a form of masochism and most certainly insanity.

## **Transgender = transhumanism**

When something explodes out of nowhere and is suddenly everywhere it is always the Cult agenda and so it is with the tidal wave of claims and demands that have infiltrated every aspect of society under the heading of 'transgenderism'. The term 'trans' is so 'in' and this is the dictionary definition:

A prefix meaning 'across', 'through', occurring ... in loanwords from Latin, used in particular for denoting movement or conveyance from place to place (transfer; transmit; transplant) or complete change (transform; transmute), or to form adjectives meaning 'crossing', 'on the other side of', or 'going beyond' the place named (transmontane; transnational; trans-Siberian).

Transgender means to go beyond gender and transhuman means to go beyond human. Both are aspects of the Cult plan to transform the human body to a synthetic state with *no gender*. Human 2.0 is not designed to procreate and would be produced technologically with no need for parents. The new human would mean the end of parents and so men, and increasingly women, are being targeted for the deletion of their rights and status. Parental rights are disappearing at an ever-quickenning speed for the same reason. The new human would have no need for men or women when there is no procreation and no gender. Perhaps the transgender movement that appears to be in a permanent state of frenzy might now contemplate on how it is being used. This was never about transgender rights which are only the interim excuse for confusing gender, particularly in the young, on the road to *fusing* gender. Transgender activism is not an end; it is a *means* to an end. We see again the technique of creative destruction in which you destroy the status quo to 'build back better' in the form that you want. The gender status quo had to be

destroyed by persuading the Cult-created Woke mentality to believe that you can have 100 genders or more. A programme for 9 to 12 year olds produced by the Cult-owned BBC promoted the 100 genders narrative. The very idea may be the most monumental nonsense, but it is not what is true that counts, only what you can make people *believe* is true. Once the gender of  $2 + 2 = 4$  has been dismantled through indoctrination, intimidation and  $2 + 2 = 5$  then the new no-gender normal can take its place with Human 2.0.

Aldous Huxley revealed the plan in his prophetic *Brave New World* in 1932:

Natural reproduction has been done away with and children are created, decanted', and raised in 'hatcheries and conditioning centres'. From birth, people are genetically designed to fit into one of five castes, which are further split into 'Plus' and 'Minus' members and designed to fulfil predetermined positions within the social and economic strata of the World State.

How could Huxley know this in 1932? For the same reason George Orwell knew about the Big Brother state in 1948, Cult insiders I have quoted knew about it in 1969, and I have known about it since the early 1990s. If you are connected to the Cult or you work your balls off to uncover the plan you can predict the future. The process is simple. If there is a plan for the world and nothing intervenes to stop it then it will happen. Thus if you communicate the plan ahead of time you are perceived to have predicted the future, but you haven't. You have revealed the plan which without intervention will become the human future. The whole reason I have done what I have is to alert enough people to inspire an intervention and maybe at last that time has come with the Cult and its intentions now so obvious to anyone with a brain in working order.

## **The future is here**

Technological wombs that Huxley described to replace parent procreation are already being developed and they are only the projects we know about in the public arena. Israeli scientists told *The Times of Israel* in March, 2021, that they have grown 250-cell embryos



into mouse fetuses with fully formed organs using artificial wombs in a development they say could pave the way for gestating humans outside the womb. Professor Jacob Hanna of the Weizmann Institute of Science said:

We took mouse embryos from the mother at day five of development, when they are just of 250 cells, and had them in the incubator from day five until day 11, by which point they had grown all their organs.

By day 11 they make their own blood and have a beating heart, a fully developed brain. Anybody would look at them and say, 'this is clearly a mouse foetus with all the characteristics of a mouse.' It's gone from being a ball of cells to being an advanced foetus.

A special liquid is used to nourish embryo cells in a laboratory dish and they float on the liquid to duplicate the first stage of embryonic development. The incubator creates all the right conditions for its development, Hanna said. The liquid gives the embryo 'all the nutrients, hormones and sugars they need' along with a custom-made electronic incubator which controls gas concentration, pressure and temperature. The cutting-edge in the underground bases and other secret locations will be light years ahead of that, however, and this was reported by the London *Guardian* in 2017:

We are approaching a biotechnological breakthrough. Ectogenesis, the invention of a complete external womb, could completely change the nature of human reproduction. In April this year, researchers at the Children's Hospital of Philadelphia announced their development of an artificial womb.

The article was headed 'Artificial wombs could soon be a reality. What will this mean for women?' What would it mean for children is an even bigger question. No mother to bond with only a machine in preparation for a life of soulless interaction and control in a world governed by machines (see the *Matrix* movies). Now observe the calculated manipulations of the 'Covid' hoax as human interaction and warmth has been curtailed by distancing, isolation and fear with people communicating via machines on a scale never seen before.

These are all dots in the same picture as are all the personal assistants, gadgets and children's toys through which kids and adults communicate with AI as if it is human. The AI 'voice' on Sat-Nav should be included. All these things are psychological preparation for the Cult endgame. Before you can make a physical connection with AI you have to make a psychological connection and that is what people are being conditioned to do with this ever gathering human-AI interaction. Movies and TV programmes depicting the transhuman, robot dystopia relate to a phenomenon known as 'pre-emptive programming' in which the world that is planned is portrayed everywhere in movies, TV and advertising. This is conditioning the conscious and subconscious mind to become familiar with the planned reality to dilute resistance when it happens for real. What would have been a shock such is the change is made less so. We have young children put on the road to transgender transition surgery with puberty blocking drugs at an age when they could never be able to make those life-changing decisions.

Rachel Levine, a professor of paediatrics and psychiatry who believes in treating children this way, became America's highest-ranked openly-transgender official when she was confirmed as US Assistant Secretary at the Department of Health and Human Services after being nominated by Joe Biden (the Cult). Activists and governments press for laws to deny parents a say in their children's transition process so the kids can be isolated and manipulated into agreeing to irreversible medical procedures. A Canadian father Robert Hoogland was denied bail by the Vancouver Supreme Court in 2021 and remained in jail for breaching a court order that he stay silent over his young teenage daughter, a minor, who was being offered life-changing hormone therapy without parental consent. At the age of 12 the girl's 'school counsellor' said she may be transgender, referred her to a doctor and told the school to treat her like a boy. This is another example of state-serving schools imposing ever more control over children's lives while parents have ever less.

Contemptible and extreme child abuse is happening all over the world as the Cult gender-fusion operation goes into warp-speed.

### **Why the war on men – and now women?**

The question about what artificial wombs mean for women should rightly be asked. The answer can be seen in the deletion of women's rights involving sport, changing rooms, toilets and status in favour of people in male bodies claiming to identify as women. I can identify as a mountain climber, but it doesn't mean I can climb a mountain any more than a biological man can be a biological woman. To believe so is a triumph of belief over factual reality which is the very perceptual basis of everything Woke. Women's sport is being destroyed by allowing those with male bodies who say they identify as female to 'compete' with girls and women. Male body 'women' dominate 'women's' competition with their greater muscle mass, bone density, strength and speed. With that disadvantage sport for women loses all meaning. To put this in perspective nearly 300 American high school boys can run faster than the quickest woman sprinter in the world. Women are seeing their previously protected spaces invaded by male bodies simply because they claim to identify as women. That's all they need to do to access all women's spaces and activities under the Biden 'Equality Act' that destroys equality for women with the usual Orwellian Woke inversion. Male sex offenders have already committed rapes in women's prisons after claiming to identify as women to get them transferred. Does this not matter to the Woke 'equality' hypocrites? Not in the least. What matters to Cult manipulators and funders behind transgender activists is to advance gender fusion on the way to the no-gender 'human'. When you are seeking to impose transparent nonsense like this, or the 'Covid' hoax, the only way the nonsense can prevail is through censorship and intimidation of dissenters, deletion of factual information, and programming of the unquestioning, bewildered and naive. You don't have to scan the world for long to see that all these things are happening.

Many women's rights organisations have realised that rights and status which took such a long time to secure are being eroded and that it is systematic. Kara Dansky of the global Women's Human Rights Campaign said that Biden's transgender executive order immediately he took office, subsequent orders, and Equality Act legislation that followed 'seek to erase women and girls in the law as a category'. *Exactly*. I said during the long ago-started war on men (in which many women play a crucial part) that this was going to turn into a war on them. The Cult is phasing out *both* male and female genders. To get away with that they are brought into conflict so they are busy fighting each other while the Cult completes the job with no unity of response. Unity, people, *unity*. We need unity everywhere. Transgender is the only show in town as the big step towards the no-gender human. It's not about rights for transgender people and never has been. Woke political correctness is deleting words relating to genders to the same end. Wokers believe this is to be 'inclusive' when the opposite is true. They are deleting words describing gender because gender *itself* is being deleted by Human 2.0. Terms like 'man', 'woman', 'mother' and 'father' are being deleted in the universities and other institutions to be replaced by the *no-gender*, not trans-gender, 'individuals' and 'guardians'. Women's rights campaigner Maria Keffler of Partners for Ethical Care said: 'Children are being taught from kindergarten upward that some boys have a vagina, some girls have a penis, and that kids can be any gender they want to be.' Do we really believe that suddenly countries all over the world at the same time had the idea of having drag queens go into schools or read transgender stories to very young children in the local library? It's coldly-calculated confusion of gender on the way to the fusion of gender. Suzanne Vierling, a psychologist from Southern California, made another important point:

Yesterday's slave woman who endured gynecological medical experiments is today's girl-child being butchered in a booming gender-transitioning sector. Ovaries removed, pushing her into menopause and osteoporosis, uncharted territory, and parents' rights and authority decimated.

The erosion of parental rights is a common theme in line with the Cult plans to erase the very concept of parents and 'ovaries removed, pushing her into menopause' means what? Those born female lose the ability to have children – another way to discontinue humanity as we know it.

### **Eliminating Human 1.0 (before our very eyes)**

To pave the way for Human 2.0 you must phase out Human 1.0. This is happening through plummeting sperm counts and making women infertile through an onslaught of chemicals, radiation (including smartphones in pockets of men) and mRNA 'vaccines'. Common agriculture pesticides are also having a devastating impact on human fertility. I have been tracking collapsing sperm counts in the books for a long time and in 2021 came a book by fertility scientist and reproductive epidemiologist Shanna Swan, *Count Down: How Our Modern World Is Threatening Sperm Counts, Altering Male and Female Reproductive Development and Imperiling the Future of the Human Race*. She reports how the global fertility rate dropped by *half* between 1960 and 2016 with America's birth rate 16 percent below where it needs to be to sustain the population. Women are experiencing declining egg quality, more miscarriages, and more couples suffer from infertility. Other findings were an increase in erectile dysfunction, infant boys developing more genital abnormalities, male problems with conception, and plunging levels of the male hormone testosterone which would explain why so many men have lost their backbone and masculinity. This has been very evident during the 'Covid' hoax when women have been prominent among the Pushbackers and big strapping blokes have bowed their heads, covered their faces with a nappy and quietly submitted. Mind control expert Cathy O'Brien also points to how global education introduced the concept of 'we're all winners' in sport and classrooms: 'Competition was defused, and it in turn defused a sense of fighting back.' This is another version of the 'equity' doctrine in which you drive down rather than raise up. What a contrast in Cult-controlled China with its global ambitions

where the government published plans in January, 2021, to 'cultivate masculinity' in boys from kindergarten through to high school in the face of a 'masculinity crisis'. A government adviser said boys would be soon become 'delicate, timid and effeminate' unless action was taken. Don't expect any similar policy in the targeted West. A 2006 study showed that a 65-year-old man in 2002 had testosterone levels *15 percent* lower than a 65-year-old man in 1987 while a 2020 study found a similar story with young adults and adolescents. Men are getting prescriptions for testosterone replacement therapy which causes an even greater drop in sperm count with up to 99 percent seeing sperm counts drop to zero during the treatment. More sperm is defective and malfunctioning with some having two heads or not pursuing an egg.

A class of *synthetic* chemicals known as phthalates are being blamed for the decline. These are found everywhere in plastics, shampoos, cosmetics, furniture, flame retardants, personal care products, pesticides, canned foods and even receipts. Why till receipts? Everyone touches them. Let no one delude themselves that all this is not systematic to advance the long-time agenda for human body transformation. Phthalates mimic hormones and disrupt the hormone balance causing testosterone to fall and genital birth defects in male infants. Animals and fish have been affected in the same way due to phthalates and other toxins in rivers. When fish turn gay or change sex through chemicals in rivers and streams it is a pointer to why there has been such an increase in gay people and the sexually confused. It doesn't matter to me what sexuality people choose to be, but if it's being affected by chemical pollution and consumption then we need to know. Does anyone really think that this is not connected to the transgender agenda, the war on men and the condemnation of male 'toxic masculinity'? You watch this being followed by 'toxic femininity'. It's already happening. When breastfeeding becomes 'chest-feeding', pregnant women become pregnant people along with all the other Woke claptrap you know that the world is going insane and there's a Cult scam in progress. Transgender activists are promoting the Cult agenda while Cult

billionaires support and fund the insanity as they laugh themselves to sleep at the sheer stupidity for which humans must be infamous in galaxies far, far away.

### **'Covid vaccines' and female infertility**

We can now see why the 'vaccine' has been connected to potential infertility in women. Dr Michael Yeadon, former Vice President and Chief Scientific Advisor at Pfizer, and Dr Wolfgang Wodarg in Germany, filed a petition with the European Medicines Agency in December, 2020, urging them to stop trials for the Pfizer/BioNTech shot and all other mRNA trials until further studies had been done. They were particularly concerned about possible effects on fertility with 'vaccine'-produced antibodies attacking the protein Syncytin-1 which is responsible for developing the placenta. The result would be infertility 'of indefinite duration' in women who have the 'vaccine' with the placenta failing to form. Section 10.4.2 of the Pfizer/BioNTech trial protocol says that pregnant women or those who might become so should not have mRNA shots. Section 10.4 warns men taking mRNA shots to 'be abstinent from heterosexual intercourse' and not to donate sperm. The UK government said that it *did not know* if the mRNA procedure had an effect on fertility. *Did not know?* These people have to go to jail. UK government advice did not recommend at the start that pregnant women had the shot and said they should avoid pregnancy for at least two months after 'vaccination'. The 'advice' was later updated to pregnant women should only have the 'vaccine' if the benefits outweighed the risks to mother and foetus. What the hell is that supposed to mean? Then 'spontaneous abortions' began to appear and rapidly increase on the adverse reaction reporting schemes which include only a fraction of adverse reactions. Thousands and ever-growing numbers of 'vaccinated' women are describing changes to their menstrual cycle with heavier blood flow, irregular periods and menstruating again after going through the menopause – all links to reproduction effects. Women are passing blood clots and the lining of their uterus while men report erectile dysfunction and blood effects. Most

significantly of all *unvaccinated* women began to report similar menstrual changes after interaction with '*vaccinated*' people and men and children were also affected with bleeding noses, blood clots and other conditions. 'Shedding' is when vaccinated people can emit the content of a vaccine to affect the unvaccinated, but this is different. 'Vaccinated' people were not shedding a 'live virus' allegedly in 'vaccines' as before because the fake 'Covid vaccines' involve synthetic material and other toxicity. Doctors exposing what is happening prefer the term 'transmission' to shedding. Somehow those that have had the shots are transmitting effects to those that haven't. Dr Carrie Madej said the nano-content of the 'vaccines' can 'act like an antenna' to others around them which fits perfectly with my own conclusions. This 'vaccine' transmission phenomenon was becoming known as the book went into production and I deal with this further in the Postscript.

Vaccine effects on sterility are well known. The World Health Organization was accused in 2014 of sterilising millions of women in Kenya with the evidence confirmed by the content of the vaccines involved. The same WHO behind the 'Covid' hoax admitted its involvement for more than ten years with the vaccine programme. Other countries made similar claims. Charges were lodged by Tanzania, Nicaragua, Mexico, and the Philippines. The Gardasil vaccine claimed to protect against a genital 'virus' known as HPV has also been linked to infertility. Big Pharma and the WHO (same thing) are criminal and satanic entities. Then there's the Bill Gates Foundation which is connected through funding and shared interests with 20 pharmaceutical giants and laboratories. He stands accused of directing the policy of United Nations Children's Fund (UNICEF), vaccine alliance GAVI, and other groupings, to advance the vaccine agenda and silence opposition at great cost to women and children. At the same time Gates wants to reduce the global population. Coincidence?

**Great Reset = Smart Grid = new human**



The Cult agenda I have been exposing for 30 years is now being openly promoted by Cult assets like Gates and Klaus Schwab of the World Economic Forum under code-terms like the 'Great Reset', 'Build Back Better' and 'a rare but narrow window of opportunity to reflect, reimagine, and reset our world'. What provided this 'rare but narrow window of opportunity'? The 'Covid' hoax did. Who created that? *They* did. My books from not that long ago warned about the planned 'Internet of Things' (IoT) and its implications for human freedom. This was the plan to connect all technology to the Internet and artificial intelligence and today we are way down that road with an estimated 36 billion devices connected to the World Wide Web and that figure is projected to be 76 billion by 2025. I further warned that the Cult planned to go beyond that to the Internet of *Everything* when the human brain was connected via AI to the Internet and Kurzweil's 'cloud'. Now we have Cult operatives like Schwab calling for precisely that under the term 'Internet of Bodies', a fusion of the physical, digital and biological into one centrally-controlled Smart Grid system which the Cult refers to as the 'Fourth Industrial Revolution'. They talk about the 'biological', but they really mean the synthetic-biological which is required to fully integrate the human body and brain into the Smart Grid and artificial intelligence planned to replace the human mind. We have everything being synthetically manipulated including the natural world through GMO and smart dust, the food we eat and the human body itself with synthetic 'vaccines'. I said in *The Answer* that we would see the Cult push for synthetic meat to replace animals and in February, 2021, the so predictable psychopath Bill Gates called for the introduction of synthetic meat to save us all from 'climate change'. The climate hoax just keeps on giving like the 'Covid' hoax. The war on meat by vegan activists is a carbon (oops, sorry) copy of the manipulation of transgender activists. They have no idea (except their inner core) that they are being used to promote and impose the agenda of the Cult or that they are only the *vehicle* and not the *reason*. This is not to say those who choose not to eat meat shouldn't be respected and supported in that right, but there are ulterior motives

for those in power. A *Forbes* article in December, 2019, highlighted the plan so beloved of Schwab and the Cult under the heading: 'What Is The Internet of Bodies? And How Is It Changing Our World?' The article said the human body is the latest data platform (remember 'our vaccine is an operating system'). *Forbes* described the plan very accurately and the words could have come straight out of my books from long before:

The Internet of Bodies (IoB) is an extension of the IoT and basically connects the human body to a network through devices that are ingested, implanted, or connected to the body in some way. Once connected, data can be exchanged, and the body and device can be remotely monitored and controlled.

They were really describing a human hive mind with human perception centrally-dictated via an AI connection as well as allowing people to be 'remotely monitored and controlled'. Everything from a fridge to a human mind could be directed from a central point by these insane psychopaths and 'Covid vaccines' are crucial to this. *Forbes* explained the process I mentioned earlier of holdable and wearable technology followed by implantable. The article said there were three generations of the Internet of Bodies that include:

- Body external: These are wearable devices such as Apple Watches or Fitbits that can monitor our health.
- Body internal: These include pacemakers, cochlear implants, and digital pills that go inside our bodies to monitor or control various aspects of health.
- Body embedded: The third generation of the Internet of Bodies is embedded technology where technology and the human body are melded together and have a real-time connection to a remote machine.

*Forbes* noted the development of the Brain Computer Interface (BCI) which merges the brain with an external device for monitoring and controlling in real-time. 'The ultimate goal is to help restore function to individuals with disabilities by using brain signals rather than conventional neuromuscular pathways.' Oh, do fuck off. The goal of brain interface technology is controlling human thought and emotion from the central point in a hive mind serving its masters wishes. Many people are now agreeing to be chipped to open doors without a key. You can recognise them because they'll be wearing a mask, social distancing and lining up for the 'vaccine'. The Cult plans a Great Reset money system after they have completed the demolition of the global economy in which 'money' will be exchanged through communication with body operating systems. Rand Corporation, a Cult-owned think tank, said of the Internet of Bodies or IoB:

Internet of Bodies technologies fall under the broader IoT umbrella. But as the name suggests, IoB devices introduce an even more intimate interplay between humans and gadgets. IoB devices monitor the human body, collect health metrics and other personal information, and transmit those data over the Internet. Many devices, such as fitness trackers, are already in use ... IoB devices ... and those in development can track, record, and store users' whereabouts, bodily functions, and what they see, hear, and even think.

Schwab's World Economic Forum, a long-winded way of saying 'fascism' or 'the Cult', has gone full-on with the Internet of Bodies in the 'Covid' era. 'We're entering the era of the Internet of Bodies', it declared, 'collecting our physical data via a range of devices that can be implanted, swallowed or worn'. The result would be a huge amount of health-related data that could improve human wellbeing around the world, and prove crucial in fighting the 'Covid-19 pandemic'. Does anyone think these clowns care about 'human wellbeing' after the death and devastation their pandemic hoax has purposely caused? Schwab and co say we should move forward with the Internet of Bodies because 'Keeping track of symptoms could help us stop the spread of infection, and quickly detect new cases'. How wonderful, but keeping track' is all they are really bothered

about. Researchers were investigating if data gathered from smartwatches and similar devices could be used as viral infection alerts by tracking the user's heart rate and breathing. Schwab said in his 2018 book *Shaping the Future of the Fourth Industrial Revolution*:

The lines between technologies and beings are becoming blurred and not just by the ability to create lifelike robots or synthetics. Instead it is about the ability of new technologies to literally become part of us. Technologies already influence how we understand ourselves, how we think about each other, and how we determine our realities. As the technologies ... give us deeper access to parts of ourselves, we may begin to integrate digital technologies into our bodies.

You can see what the game is. Twenty-four hour control and people – if you could still call them that – would never know when something would go ping and take them out of circulation. It's the most obvious rush to a global fascist dictatorship and the complete submission of humanity and yet still so many are locked away in their Cult-induced perceptual coma and can't see it.

### **Smart Grid control centres**

The human body is being transformed by the 'vaccines' and in other ways into a synthetic cyborg that can be attached to the global Smart Grid which would be controlled from a central point and other sub-locations of Grid manipulation. Where are these planned to be? Well, China for a start which is one of the Cult's biggest centres of operation. The technological control system and technocratic rule was incubated here to be unleashed across the world after the 'Covid' hoax came out of China in 2020. Another Smart Grid location that will surprise people new to this is Israel. I have exposed in *The Trigger* how Sabbatian technocrats, intelligence and military operatives were behind the horrors of 9/11 and not 19 Arab hijackers' who somehow manifested the ability to pilot big passenger airliners when instructors at puddle-jumping flying schools described some of them as a joke. The 9/11 attacks were made possible through control of civilian and military air computer systems and those of the White House, Pentagon and connected agencies. See *The Trigger* – it

will blow your mind. The controlling and coordinating force were the Sabbatian networks in Israel and the United States which by then had infiltrated the entire US government, military and intelligence system. The real name of the American Deep State is 'Sabbatian State'. Israel is a tiny country of only nine million people, but it is one of the global centres of cyber operations and fast catching Silicon Valley in importance to the Cult. Israel is known as the 'start-up nation' for all the cyber companies spawned there with the Sabbatian specialisation of 'cyber security' that I mentioned earlier which gives those companies access to computer systems of their clients in real time through 'backdoors' written into the coding when security software is downloaded. The Sabbatian centre of cyber operations outside Silicon Valley is the Israeli military Cyber Intelligence Unit, the biggest infrastructure project in Israel's history, headquartered in the desert-city of Beersheba and involving some 20,000 'cyber soldiers'. Here are located a literal army of Internet trolls scanning social media, forums and comment lists for anyone challenging the Cult agenda. The UK military has something similar with its 77th Brigade and associated operations. The Beersheba complex includes research and development centres for other Cult operations such as Intel, Microsoft, IBM, Google, Apple, Hewlett-Packard, Cisco Systems, Facebook and Motorola. [Techcrunch.com](http://Techcrunch.com) ran an article about the Beersheba global Internet technology centre headlined 'Israel's desert city of Beersheba is turning into a cybertech oasis':

The military's massive relocation of its prestigious technology units, the presence of multinational and local companies, a close proximity to Ben Gurion University and generous government subsidies are turning Beersheba into a major global cybertech hub. Beersheba has all of the ingredients of a vibrant security technology ecosystem, including Ben Gurion University with its graduate program in cybersecurity and Cyber Security Research Center, and the presence of companies such as EMC, Deutsche Telekom, PayPal, Oracle, IBM, and Lockheed Martin. It's also the future home of the INCB (Israeli National Cyber Bureau); offers a special income tax incentive for cyber security companies, and was the site for the relocation of the army's intelligence corps units.

Sabbatians have taken over the cyber world through the following process: They scan the schools for likely cyber talent and develop them at Ben Gurion University and their period of conscription in the Israeli Defense Forces when they are stationed at the Beersheba complex. When the cyber talented officially leave the army they are funded to start cyber companies with technology developed by themselves or given to them by the state. Much of this is stolen through backdoors of computer systems around the world with America top of the list. Others are sent off to Silicon Valley to start companies or join the major ones and so we have many major positions filled by apparently 'Jewish' but really Sabbatian operatives. Google, YouTube and Facebook are all run by 'Jewish' CEOs while Twitter is all but run by ultra-Zionist hedge-fund shark Paul Singer. At the centre of the Sabbatian global cyber web is the Israeli army's Unit 8200 which specialises in hacking into computer systems of other countries, inserting viruses, gathering information, instigating malfunction, and even taking control of them from a distance. A long list of Sabbatians involved with 9/11, Silicon Valley and Israeli cyber security companies are operatives of Unit 8200. This is not about Israel. It's about the Cult. Israel is planned to be a Smart Grid hub as with China and what is happening at Beersheba is not for the benefit of Jewish people who are treated disgustingly by the Sabbatian elite that control the country. A glance at the Nuremberg Codes will tell you that.

The story is much bigger than 'Covid', important as that is to where we are being taken. Now, though, it's time to really strap in. There's more ... much more ...

## CHAPTER ELEVEN

### Who controls the Cult?

*Awake, arise or be forever fall'n*  
John Milton, *Paradise Lost*

I have exposed this far the level of the Cult conspiracy that operates in the world of the seen and within the global secret society and satanic network which operates in the shadows one step back from the seen. The story, however, goes much deeper than that.

The 'Covid' hoax is major part of the Cult agenda, but only part, and to grasp the biggest picture we have to expand our attention beyond the realm of human sight and into the infinity of possibility that we cannot see. It is from here, ultimately, that humanity is being manipulated into a state of total control by the force which dictates the actions of the Cult. How much of reality can we see? Next to damn all is the answer. We may appear to see all there is to see in the 'space' our eyes survey and observe, but little could be further from the truth. The human 'world' is only a tiny band of frequency that the body's visual and perceptual systems can decode into *perception* of a 'world'. According to mainstream science the electromagnetic spectrum is 0.005 percent of what exists in the Universe (Fig 10). The maximum estimate I have seen is 0.5 percent and either way it's miniscule. I say it is far, far, smaller even than 0.005 percent when you compare reality we see with the totality of reality that we don't. Now get this if you are new to such information: Visible light, the only band of frequency that we can see, is a *fraction* of the 0.005

percent (Fig 11 overleaf). Take this further and realise that our universe is one of infinite universes and that universes are only a fragment of overall reality – *infinite* reality. Then compare that with the almost infinitesimal frequency band of visible light or human sight. You see that humans are as near blind as it is possible to be without actually being so. Artist and filmmaker, Sergio Toporek, said:

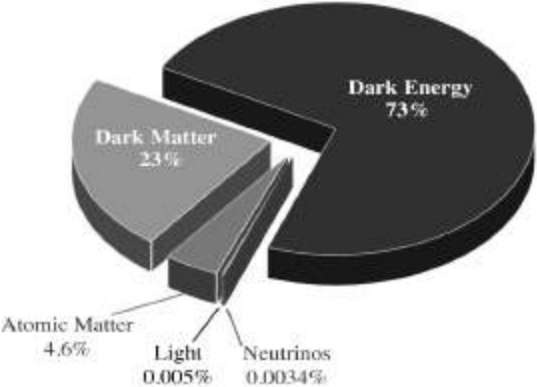


Figure 10: Humans can perceive such a tiny band of visual reality it's laughable.

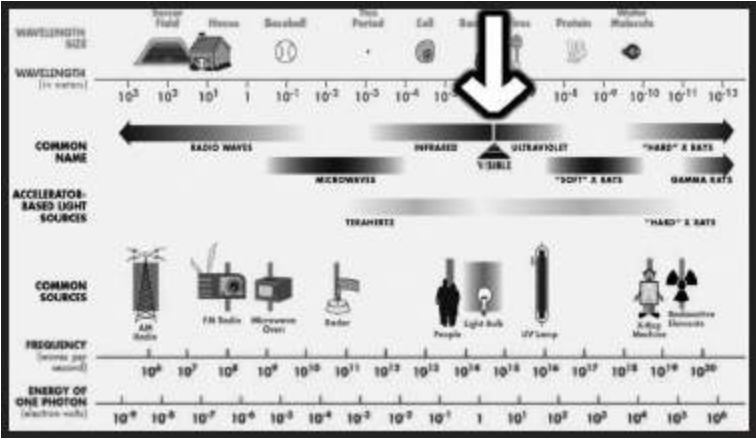


Figure 11: We can see a smear of the 0.005 percent electromagnetic spectrum, but we still know it all. Yep, makes sense.

Consider that you can see less than 1% of the electromagnetic spectrum and hear less than 1% of the acoustic spectrum. 90% of the cells in your body carry their own microbial DNA and are not 'you'. The atoms in your body are 99.9999999999999999% empty space and none of them are the ones you were born with ... Human beings have 46 chromosomes, two less than a potato.



The existence of the rainbow depends on the conical photoreceptors in your eyes; to animals without cones, the rainbow does not exist. So you don't just look at a rainbow, you create it. This is pretty amazing, especially considering that all the beautiful colours you see represent less than 1% of the electromagnetic spectrum.

Suddenly the 'world' of humans looks a very different place. Take into account, too, that Planet Earth when compared with the projected size of this single universe is the equivalent of a billionth of a pinhead. Imagine the ratio that would be when compared to infinite reality. To think that Christianity once insisted that Earth and humanity were the centre of everything. This background is vital if we are going to appreciate the nature of 'human' and how we can be manipulated by an unseen force. To human visual reality virtually *everything* is unseen and yet the prevailing perception within the institutions and so much of the public is that if we can't see it, touch it, hear it, taste it and smell it then it cannot exist. Such perception is indoctrinated and encouraged by the Cult and its agents because it isolates believers in the strictly limited, village-idiot, realm of the five senses where perceptions can be firewalled and information controlled. Most of those perpetuating the 'this-world-is-all-there-is' insanity are themselves indoctrinated into believing the same delusion. While major players and influencers know that official reality is laughable most of those in science, academia and medicine really believe the nonsense they peddle and teach succeeding generations. Those who challenge the orthodoxy are dismissed as nutters and freaks to protect the manufactured illusion from exposure. Observe the dynamic of the 'Covid' hoax and you will see how that takes the same form. The inner-circle psychopaths knows it's a gigantic scam, but almost the entirety of those imposing their fascist rules believe that 'Covid' is all that they're told it is.

## **Stolen identity**

Ask people who they are and they will give you their name, place of birth, location, job, family background and life story. Yet that is not who they are – it is what they are *experiencing*. The difference is *absolutely crucial*. The true 'I', the eternal, infinite 'I', is consciousness,

a state of being aware. Forget 'form'. That is a vehicle for a brief experience. Consciousness does not come *from* the brain, but *through* the brain and even that is more symbolic than literal. We are awareness, pure awareness, and this is what withdraws from the body at what we call 'death' to continue our eternal beingness, *isness*, in other realms of reality within the limitlessness of infinity or the Biblical 'many mansions in my father's house'. Labels of a human life, man, woman, transgender, black, white, brown, nationality, circumstances and income are not who we are. They are what we are – awareness – is *experiencing* in a brief connection with a band of frequency we call 'human'. The labels are not the self; they are, to use the title of one of my books, a *Phantom Self*. I am not David Icke born in Leicester, England, on April 29th, 1952. I am the consciousness *having that experience*. The Cult and its non-human masters seek to convince us through the institutions of 'education', science, medicine, media and government that what we are *experiencing* is who we *are*. It's so easy to control and direct perception locked away in the bewildered illusions of the five senses with no expanded radar. Try, by contrast, doing the same with a humanity aware of its true self and its true power to consciously create its reality and experience. How is it possible to do this? We do it all day every day. If you perceive yourself as 'little me' with no power to impact upon your life and the world then your life experience will reflect that. You will hand the power you don't think you have to authority in all its forms which will use it to control your experience. This, in turn, will appear to confirm your perception of 'little me' in a self-fulfilling feedback loop. But that is what 'little me' really is – a *perception*. We are all 'big-me', infinite me, and the Cult has to make us forget that if its will is to prevail. We are therefore manipulated and pressured into self-identifying with human labels and not the consciousness/awareness *experiencing* those human labels.

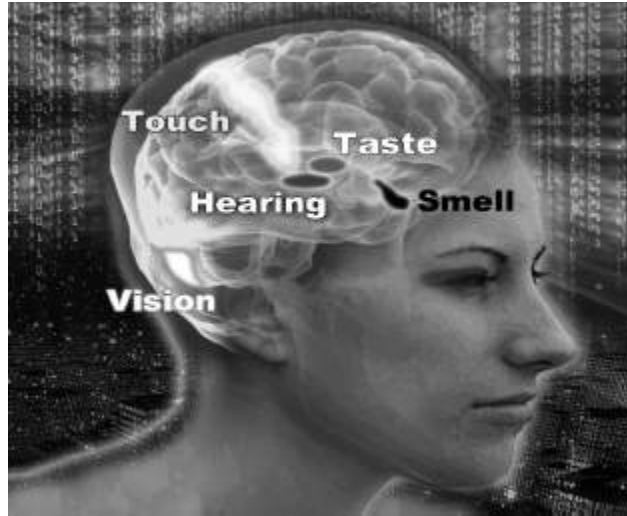
The phenomenon of identity politics is a Cult-instigated manipulation technique to sub-divide previous labels into even smaller ones. A United States university employs this list of letters to

describe student identity: LGBTTQQFAGPBDSM or lesbian, gay, bisexual, transgender, transsexual, queer, questioning, flexual, asexual, gender-fuck, polyamorous, bondage/discipline, dominance/submission and sadism/masochism. I'm sure other lists are even longer by now as people feel the need to self-identity the 'I' with the minutiae of race and sexual preference. Wokers programmed by the Cult for generations believe this is about 'inclusivity' when it's really the Cult locking them away into smaller and smaller versions of Phantom Self while firewalling them from the influence of their true self, the infinite, eternal 'I'. You may notice that my philosophy which contends that we are all unique points of attention/awareness within the same infinite whole or Oneness is the ultimate non-racism. The very sense of Oneness makes the judgement of people by their body-type, colour or sexuality utterly ridiculous and confirms that racism has no understanding of reality (including anti-white racism). Yet despite my perception of life Cult agents and fast-asleep Wokers label me racist to discredit my information while they are themselves phenomenally racist and sexist. All they see is race and sexuality and they judge people as good or bad, demons or untouchables, by their race and sexuality. All they see is *Phantom Self* and perceive themselves in terms of Phantom Self. They are pawns and puppets of the Cult agenda to focus attention and self-identity in the five senses and play those identities against each other to divide and rule. Columbia University has introduced segregated graduations in another version of social distancing designed to drive people apart and teach them that different racial and cultural groups have nothing in common with each other. The last thing the Cult wants is unity. Again the pump-primers of this will be Cult operatives in the knowledge of what they are doing, but the rest are just the Phantom Self blind leading the Phantom Self blind. We *do* have something in common – we are all *the same consciousness* having different temporary experiences.

## **What is this 'human'?**

Yes, what *is* 'human'? That is what we are supposed to be, right? I mean 'human'? True, but 'human' is the experience not the 'I'. Break it down to basics and 'human' is the way that information is processed. If we are to experience and interact with this band of frequency we call the 'world' we must have a vehicle that operates within that band of frequency. Our consciousness in its prime form cannot do that; it is way beyond the frequency of the human realm. My consciousness or awareness could not tap these keys and pick up the cup in front of me in the same way that radio station A cannot interact with radio station B when they are on different frequencies. The human body is the means through which we have that interaction. I have long described the body as a biological computer which processes information in a way that allows consciousness to experience this reality. The body is a receiver, transmitter and processor of information in a particular way that we call human. We visually perceive only the world of the five senses in a wakened state – that is the limit of the body's visual decoding system. In truth it's not even visual in the way we experience 'visual reality' as I will come to in a moment. We are 'human' because the body processes the information sources of human into a reality and behaviour system that we *perceive* as human. Why does an elephant act like an elephant and not like a human or a duck? The elephant's biological computer is a different information field and processes information according to that program into a visual and behaviour type we call an elephant. The same applies to everything in our reality. These body information fields are perpetuated through procreation (like making a copy of a software program). The Cult wants to break that cycle and intervene technologically to transform the human information field into one that will change what we call humanity. If it can change the human information field it will change the way that field processes information and change humanity both 'physically' and psychologically. Hence the *messenger* (information) RNA 'vaccines' and so much more that is targeting human genetics by changing the body's information – *messaging* – construct through food, drink, radiation, toxicity and other means.

Reality that we experience is nothing like reality as it really is in the same way that the reality people experience in virtual reality games is not the reality they are really living in. The game is only a decoded source of information that appears to be a reality. Our world is also an information construct – a *simulation* (more later). In its base form our reality is a wavefield of information much the same in theme as Wi-Fi. The five senses decode wavefield information into electrical information which they communicate to the brain to decode into holographic (illusory ‘physical’) information. Different parts of the brain specialise in decoding different senses and the information is fused into a reality that appears to be outside of us but is really inside the brain and the genetic structure in general (Fig 12 overleaf). DNA is a receiver-transmitter of information and a vital part of this decoding process and the body’s connection to other realities. Change DNA and you change the way we decode and connect with reality – see ‘Covid vaccines’. Think of computers decoding Wi-Fi. You have information encoded in a radiation field and the computer decodes that information into a very different form on the screen. You can’t see the Wi-Fi until its information is made manifest on the screen and the information on the screen is inside the computer and not outside. I have just described how we decode the ‘human world’. All five senses decode the waveform ‘Wi-Fi’ field into electrical signals and the brain (computer) constructs reality inside the brain and not outside – ‘You don’t just look at a rainbow, you create it’. Sound is a simple example. We don’t hear sound until the brain decodes it. Waveform sound waves are picked up by the hearing sense and communicated to the brain in an electrical form to be decoded into the sounds that we hear. Everything we hear is inside the brain along with everything we see, feel, smell and taste. Words and language are waveform fields generated by our vocal chords which pass through this process until they are decoded by the brain into words that we hear. Different languages are different frequency fields or sound waves generated by vocal chords. Late British philosopher Alan Watts said:



**Figure 12:** The brain receives information from the five senses and constructs from that our perceived reality.

[Without the brain] the world is devoid of light, heat, weight, solidity, motion, space, time or any other imaginable feature. All these phenomena are interactions, or transactions, of vibrations with a certain arrangement of neurons.

That's exactly what they are and scientist Robert Lanza describes in his book, *Biocentrism*, how we decode electromagnetic waves and energy into visual and 'physical' experience. He uses the example of a flame emitting photons, electromagnetic energy, each pulsing electrically and magnetically:

... these ... invisible electromagnetic waves strike a human retina, and if (and only if) the waves happen to measure between 400 and 700 nano meters in length from crest to crest, then their energy is just right to deliver a stimulus to the 8 million cone-shaped cells in the retina.

Each in turn send an electrical pulse to a neighbour neuron, and on up the line this goes, at 250 mph, until it reaches the ... occipital lobe of the brain, in the back of the head. There, a cascading complex of neurons fire from the incoming stimuli, and we subjectively perceive this experience as a yellow brightness occurring in a place we have been conditioned to call the 'external world'.

**You hear what you decode**

If a tree falls or a building collapses they make no noise unless someone is there to decode the energetic waves generated by the disturbance into what we call sound. Does a falling tree make a noise? Only if you hear it – *decode* it. Everything in our reality is a frequency field of information operating within the overall ‘Wi-Fi’ field that I call The Field. A vibrational disturbance is generated in The Field by the fields of the falling tree or building. These disturbance waves are what we decode into the sound of them falling. If no one is there to do that then neither will make any noise. Reality is created by the observer – *decoder* – and the *perceptions* of the observer affect the decoding process. For this reason different people – different *perceptions* – will perceive the same reality or situation in a different way. What one may perceive as a nightmare another will see as an opportunity. The question of why the Cult is so focused on controlling human perception now answers itself. All experienced reality is the act of decoding and we don’t experience Wi-Fi until it is decoded on the computer screen. The sight and sound of an Internet video is encoded in the Wi-Fi all around us, but we don’t see or hear it until the computer decodes that information. Taste, smell and touch are all phenomena of the brain as a result of the same process. We don’t taste, smell or feel anything except in the brain and there are pain relief techniques that seek to block the signal from the site of discomfort to the brain because if the brain doesn’t decode that signal we don’t feel pain. Pain is in the brain and only appears to be at the point of impact thanks to the feedback loop between them. We don’t see anything until electrical information from the sight senses is decoded in an area at the back of the brain. If that area is damaged we can go blind when our eyes are perfectly okay. So why do we go blind if we damage an eye? We damage the information processing between the waveform visual information and the visual decoding area of the brain. If information doesn’t reach the brain in a form it can decode then we can’t see the visual reality that it represents. What’s more the brain is decoding only a fraction of the information it receives and the rest is absorbed by the

sub-conscious mind. This explanation is from the science magazine, *Wonderpedia*:

Every second, 11 million sensations crackle along these [brain] pathways ... The brain is confronted with an alarming array of images, sounds and smells which it rigorously filters down until it is left with a manageable list of around 40. Thus 40 sensations per second make up what we perceive as reality.

The 'world' is not what people are told to believe that is it and the inner circles of the Cult *know that*.

### **Illusory 'physical' reality**

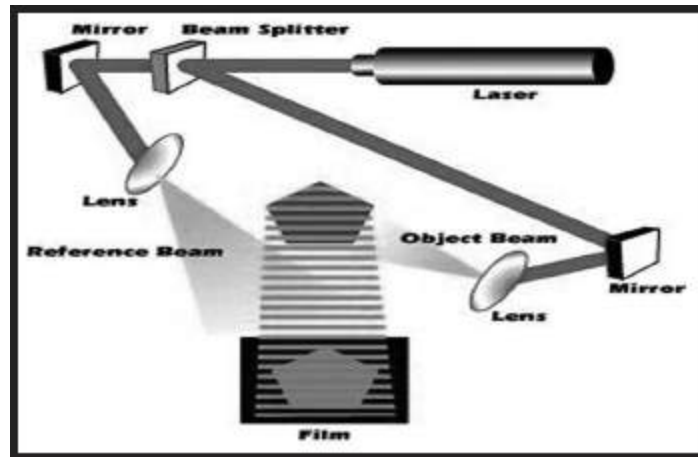
We can only see a smear of 0.005 percent of the Universe which is only one of a vast array of universes – 'mansions' – within infinite reality. Even then the brain decodes only 40 pieces of information ('sensations') from a potential *11 million* that we receive every second. Two points strike you from this immediately: The sheer breathtaking stupidity of believing we know anything so rigidly that there's nothing more to know; and the potential for these processes to be manipulated by a malevolent force to control the reality of the population. One thing I can say for sure with no risk of contradiction is that when you can perceive an almost indescribable fraction of infinite reality there is always more to know as in tidal waves of it. Ancient Greek philosopher Socrates was so right when he said that wisdom is to know how little we know. How obviously true that is when you think that we are experiencing a physical world of solidity that is neither physical nor solid and a world of apartness when everything is connected. Cult-controlled 'science' dismisses the so-called 'paranormal' and all phenomena related to that when the 'para'-normal is perfectly normal and explains the alleged 'great mysteries' which dumbfound scientific minds. There is a reason for this. A 'scientific mind' in terms of the mainstream is a material mind, a five-sense mind imprisoned in see it, touch it, hear it, smell it and taste it. Phenomena and happenings that can't be explained that way leave the 'scientific mind' bewildered and the rule is that if they



can't account for why something is happening then it can't, by definition, be happening. I beg to differ. Telepathy is thought waves passing through The Field (think wave disturbance again) to be decoded by someone able to connect with that wavelength (information). For example: You can pick up the thought waves of a friend at any distance and at the very least that will bring them to mind. A few minutes later the friend calls you. 'My god', you say, 'that's incredible – I was just thinking of you.' Ah, but *they* were thinking of *you* before they made the call and that's what you decoded. Native peoples not entrapped in five-sense reality do this so well it became known as the 'bush telegraph'. Those known as psychics and mediums (genuine ones) are doing the same only across dimensions of reality. 'Mind over matter' comes from the fact that matter and mind are the *same*. The state of one influences the state of the other. Indeed one *and* the other are illusions. They are aspects of the same field. Paranormal phenomena are all explainable so why are they still considered 'mysteries' or not happening? Once you go down this road of understanding you begin to expand awareness beyond the five senses and that's the nightmare for the Cult.



**Figure 13:** Holograms are not solid, but the best ones appear to be.



**Figure 14:** How holograms are created by capturing a waveform version of the subject image.

### **Holographic 'solidity'**

Our reality is not solid, it is holographic. We are now well aware of holograms which are widely used today. Two-dimensional information is decoded into a three-dimensional reality that is not solid although can very much appear to be (Fig 13). Holograms are created with a laser divided into two parts. One goes directly onto a holographic photographic print ('reference beam') and the other takes a waveform image of the subject ('working beam') before being directed onto the print where it 'collides' with the other half of the laser (Fig 14). This creates a *waveform* interference pattern which contains the wavefield information of whatever is being photographed (Fig 15 overleaf). The process can be likened to dropping pebbles in a pond. Waves generated by each one spread out across the water to collide with the others and create a wave representation of where the stones fell and at what speed, weight and distance. A waveform interference pattern of a hologram is akin to the waveform information in The Field which the five senses decode into electrical signals to be decoded by the brain into a holographic illusory 'physical' reality. In the same way when a laser (think human attention) is directed at the waveform interference pattern a three-dimensional version of the subject is projected into apparently 'solid' reality (Fig 16). An amazing trait of holograms reveals more 'paranormal mysteries'. Information of the *whole*

hologram is encoded in waveform in every part of the interference pattern by the way they are created. This means that every *part* of a hologram is a smaller version of the whole. Cut the interference wave-pattern into four and you won't get four parts of the image. You get quarter-sized versions of the *whole* image. The body is a hologram and the same applies. Here we have the basis of acupuncture, reflexology and other forms of healing which identify representations of the whole body in all of the parts, hands, feet, ears, everywhere. Skilled palm readers can do what they do because the information of whole body is encoded in the hand. The concept of as above, so below, comes from this.



**Figure 15:** A waveform interference pattern that holds the information that transforms into a hologram.



**Figure 16:** Holographic people including 'Elvis' holographically inserted to sing a duet with Celine Dion.

The question will be asked of why, if solidity is illusory, we can't just walk through walls and each other. The resistance is not solid against solid; it is electromagnetic field against electromagnetic field and we decode this into the *experience* of solid against solid. We should also not underestimate the power of belief to dictate reality. What you believe is impossible *will be*. Your belief impacts on your decoding processes and they won't decode what you think is impossible. What we believe we perceive and what we perceive we experience. 'Can't dos' and 'impossibles' are like a firewall in a computer system that won't put on the screen what the firewall blocks. How vital that is to understanding how human experience has been hijacked. I explain in *The Answer, Everything You Need To Know But Have Never Been Told* and other books a long list of 'mysteries' and 'paranormal' phenomena that are not mysterious and perfectly normal once you realise what reality is and how it works. 'Ghosts' can be seen to pass through 'solid' walls because the walls are not solid and the ghost is a discarnate entity operating on a frequency so different to that of the wall that it's like two radio stations sharing the same space while never interfering with each other. I have seen ghosts do this myself. The apartness of people and objects is also an illusion. Everything is connected by the Field like all sea life is connected by the sea. It's just that within the limits of our visual reality we only 'see' holographic information and not the field of information that connects everything and from which the holographic world is made manifest. If you can only see holographic 'objects' and not the field that connects them they will appear to you as unconnected to each other in the same way that we see the computer while not seeing the Wi-Fi.

### **What you don't know *can* hurt you**

Okay, we return to those 'two worlds' of human society and the Cult with its global network of interconnecting secret societies and satanic groups which manipulate through governments, corporations, media, religions, etc. The fundamental difference between them is *knowledge*. The idea has been to keep humanity

ignorant of the plan for its total enslavement underpinned by a crucial ignorance of reality – who we are and where we are – and how we interact with it. ‘Human’ should be the interaction between our expanded eternal consciousness and the five-sense body experience. We are meant to be *in* this world in terms of the five senses but not *of* this world in relation to our greater consciousness and perspective. In that state we experience the small picture of the five senses within the wider context of the big picture of awareness beyond the five senses. Put another way the five senses see the dots and expanded awareness connects them into pictures and patterns that give context to the apparently random and unconnected. Without the context of expanded awareness the five senses see only apartness and randomness with apparently no meaning. The Cult and its other-dimensional controllers seek to intervene in the frequency realm where five-sense reality is supposed to connect with expanded reality and to keep the two apart (more on this in the final chapter). When that happens five-sense mental and emotional processes are no longer influenced by expanded awareness, or the True ‘I’, and instead are driven by the isolated perceptions of the body’s decoding systems. They are in the world *and* of it. Here we have the human plight and why humanity with its potential for infinite awareness can be so easily manipulatable and descend into such extremes of stupidity.

Once the Cult isolates five-sense mind from expanded awareness it can then program the mind with perceptions and beliefs by controlling information that the mind receives through the ‘education’ system of the formative years and the media perceptual bombardment and censorship of an entire lifetime. Limit perception and a sense of the possible through limiting knowledge by limiting and skewing information while censoring and discrediting that which could set people free. As the title of another of my books says ... *And The Truth Shall Set You Free*. For this reason the last thing the Cult wants in circulation is the truth about anything – especially the reality of the eternal ‘I’ – and that’s why it is desperate to control information. The Cult knows that information becomes perception

which becomes behaviour which, collectively, becomes human society. Cult-controlled and funded mainstream 'science' denies the existence of an eternal 'I' and seeks to dismiss and trash all evidence to the contrary. Cult-controlled mainstream religion has a version of 'God' that is little more than a system of control and dictatorship that employs threats of damnation in an afterlife to control perceptions and behaviour in the here and now through fear and guilt. Neither is true and it's the 'neither' that the Cult wishes to suppress. This 'neither' is that everything is an expression, a point of attention, within an infinite state of consciousness which is the real meaning of the term 'God'.

Perceptual obsession with the 'physical body' and five-senses means that 'God' becomes personified as a bearded bloke sitting among the clouds or a raging bully who loves us if we do what 'he' wants and condemns us to the fires of hell if we don't. These are no more than a 'spiritual' fairy tales to control and dictate events and behaviour through fear of this 'God' which has bizarrely made 'God-fearing' in religious circles a state to be desired. I would suggest that fearing *anything* is not to be encouraged and celebrated, but rather deleted. You can see why 'God fearing' is so beneficial to the Cult and its religions when *they* decide what 'God' wants and what 'God' demands (the Cult demands) that everyone do. As the great American comedian Bill Hicks said satirising a Christian zealot: 'I think what God meant to say.' How much of this infinite awareness ('God') that we access is decided by how far we choose to expand our perceptions, self-identity and sense of the possible. The scale of self-identity reflects itself in the scale of awareness that we can connect with and are influenced by – how much knowing and insight we have instead of programmed perception. You cannot expand your awareness into the infinity of possibility when you believe that you are little me Peter the postman or Mary in marketing and nothing more. I'll deal with this in the concluding chapter because it's crucial to how we turnaround current events.

## **Where the Cult came from**

When I realised in the early 1990s there was a Cult network behind global events I asked the obvious question: When did it start? I took it back to ancient Rome and Egypt and on to Babylon and Sumer in Mesopotamia, the 'Land Between Two Rivers', in what we now call Iraq. The two rivers are the Tigris and Euphrates and this region is of immense historical and other importance to the Cult, as is the land called Israel only 550 miles away by air. There is much more going on with deep esoteric meaning across this whole region. It's not only about 'wars for oil'. Priceless artefacts from Mesopotamia were stolen or destroyed after the American and British invasion of Iraq in 2003 justified by the lies of Boy Bush and Tony Blair (their Cult masters) about non-existent 'weapons of mass destruction'.

Mesopotamia was the location of Sumer (about 5,400BC to 1,750BC), and Babylon (about 2,350BC to 539BC). Sabbatians may have become immensely influential in the Cult in modern times but they are part of a network that goes back into the mists of history. Sumer is said by historians to be the 'cradle of civilisation'. I disagree. I say it was the re-start of what we call human civilisation after cataclysmic events symbolised in part as the 'Great Flood' destroyed the world that existed before. These fantastic upheavals that I have been describing in detail in the books since the early 1990s appear in accounts and legends of ancient cultures across the world and they are supported by geological and biological evidence. Stone tablets found in Iraq detailing the Sumer period say the cataclysms were caused by non-human 'gods' they call the Anunnaki. These are described in terms of extraterrestrial visitations in which knowledge supplied by the Anunnaki is said to have been the source of at least one of the world's oldest writing systems and developments in astronomy, mathematics and architecture that were way ahead of their time. I have covered this subject at length in *The Biggest Secret* and *Children of the Matrix* and the same basic 'Anunnaki' story can be found in Zulu accounts in South Africa where the late and very great Zulu high shaman Credo Mutwa told me that the Sumerian Anunnaki were known by Zulus as the Chitauri or 'children of the serpent'. See my six-hour video interview with Credo on this subject entitled *The*

*Reptilian Agenda* recorded at his then home near Johannesburg in 1999 which you can watch on the Ickonic media platform.

The Cult emerged out of Sumer, Babylon and Egypt (and elsewhere) and established the Roman Empire before expanding with the Romans into northern Europe from where many empires were savagely imposed in the form of Cult-controlled societies all over the world. Mass death and destruction was their calling card. The Cult established its centre of operations in Europe and European Empires were Cult empires which allowed it to expand into a global force. Spanish and Portuguese colonialists headed for Central and South America while the British and French targeted North America. Africa was colonised by Britain, France, Belgium, the Netherlands, Portugal, Spain, Italy, and Germany. Some like Britain and France moved in on the Middle East. The British Empire was by far the biggest for a simple reason. By now Britain was the headquarters of the Cult from which it expanded to form Canada, the United States, Australia and New Zealand. The Sun never set on the British Empire such was the scale of its occupation. London remains a global centre for the Cult along with Rome and the Vatican although others have emerged in Israel and China. It is no accident that the 'virus' is alleged to have come out of China while Italy was chosen as the means to terrify the Western population into compliance with 'Covid' fascism. Nor that Israel has led the world in 'Covid' fascism and mass 'vaccination'.

You would think that I would mention the United States here, but while it has been an important means of imposing the Cult's will it is less significant than would appear and is currently in the process of having what power it does have deleted. The Cult in Europe has mostly loaded the guns for the US to fire. America has been controlled from Europe from the start through Cult operatives in Britain and Europe. The American Revolution was an illusion to make it appear that America was governing itself while very different forces were pulling the strings in the form of Cult families such as the Rothschilds through the Rockefellers and other subordinates. The Rockefellers are extremely close to Bill Gates and



established both scalpel and drug 'medicine' and the World Health Organization. They play a major role in the development and circulation of vaccines through the Rockefeller Foundation on which Bill Gates said his Foundation is based. Why wouldn't this be the case when the Rockefellers and Gates are on the same team? Cult infiltration of human society goes way back into what we call history and has been constantly expanding and centralising power with the goal of establishing a global structure to dictate everything. Look how this has been advanced in great leaps with the 'Covid' hoax.

### **The non-human dimension**

I researched and observed the comings and goings of Cult operatives through the centuries and even thousands of years as they were born, worked to promote the agenda within the secret society and satanic networks, and then died for others to replace them. Clearly there had to be a coordinating force that spanned this entire period while operatives who would not have seen the end goal in their lifetimes came and went advancing the plan over millennia. I went in search of that coordinating force with the usual support from the extraordinary synchronicity of my life which has been an almost daily experience since 1990. I saw common themes in religious texts and ancient cultures about a non-human force manipulating human society from the hidden. Christianity calls this force Satan, the Devil and demons; Islam refers to the Jinn or Djinn; Zulus have their Chitauri (spelt in other ways in different parts of Africa); and the Gnostic people in Egypt in the period around and before 400AD referred to this phenomena as the 'Archons', a word meaning rulers in Greek. Central American cultures speak of the 'Predators' among other names and the same theme is everywhere. I will use 'Archons' as a collective name for all of them. When you see how their nature and behaviour is described all these different sources are clearly talking about the same force. Gnostics described the Archons in terms of 'luminous fire' while Islam relates the Jinn to 'smokeless fire'. Some refer to beings in form that could occasionally be seen, but the most common of common theme is that they operate from

unseen realms which means almost all existence to the visual processes of humans. I had concluded that this was indeed the foundation of human control and that the Cult was operating within the human frequency band on behalf of this hidden force when I came across the writings of Gnostics which supported my conclusions in the most extraordinary way.

A sealed earthen jar was found in 1945 near the town of Nag Hammadi about 75-80 miles north of Luxor on the banks of the River Nile in Egypt. Inside was a treasure trove of manuscripts and texts left by the Gnostic people some 1,600 years earlier. They included 13 leather-bound papyrus codices (manuscripts) and more than 50 texts written in Coptic Egyptian estimated to have been hidden in the jar in the period of 400AD although the source of the information goes back much further. Gnostics oversaw the Great or Royal Library of Alexandria, the fantastic depository of ancient texts detailing advanced knowledge and accounts of human history. The Library was dismantled and destroyed in stages over a long period with the death-blow delivered by the Cult-established Roman Church in the period around 415AD. The Church of Rome was the Church of Babylon relocated as I said earlier. Gnostics were not a race. They were a way of perceiving reality. Whenever they established themselves and their information circulated the terrorists of the Church of Rome would target them for destruction. This happened with the Great Library and with the Gnostic Cathars who were burned to death by the psychopaths after a long period of oppression at the siege of the Castle of Monségur in southern France in 1244. The Church has always been terrified of Gnostic information which demolishes the official Christian narrative although there is much in the Bible that supports the Gnostic view if you read it in another way. To anyone studying the texts of what became known as the Nag Hammadi Library it is clear that great swathes of Christian and Biblical belief has its origin with Gnostics sources going back to Sumer. Gnostic themes have been twisted to manipulate the perceived reality of Bible believers. Biblical texts have been in the open for centuries where they could be changed while Gnostic

documents found at Nag Hammadi were sealed away and untouched for 1,600 years. What you see is what they wrote.

### **Use your *pneuma* not your *nous***

Gnosticism and Gnostic come from 'gnosis' which means knowledge, or rather *secret* knowledge, in the sense of spiritual awareness – knowledge about reality and life itself. The desperation of the Cult's Church of Rome to destroy the Gnostics can be understood when the knowledge they were circulating was the last thing the Cult wanted the population to know. Sixteen hundred years later the same Cult is working hard to undermine and silence me for the same reason. The dynamic between knowledge and ignorance is a constant. 'Time' appears to move on, but essential themes remain the same. We are told to 'use your nous', a Gnostic word for head/brain/intelligence. They said, however, that spiritual awakening or 'salvation' could only be secured by expanding awareness *beyond* what they called *nous* and into *pneuma* or Infinite Self. Obviously as I read these texts the parallels with what I have been saying since 1990 were fascinating to me. There is a universal truth that spans human history and in that case why wouldn't we be talking the same language 16 centuries apart? When you free yourself from the perception program of the five senses and explore expanded realms of consciousness you are going to connect with the same information no matter what the perceived 'era' within a manufactured timeline of a single and tiny range of manipulated frequency. Humans working with 'smart' technology or knocking rocks together in caves is only a timeline appearing to operate within the human frequency band. Expanded awareness and the knowledge it holds have always been there whether the era be Stone Age or computer age. We can only access that knowledge by opening ourselves to its frequency which the five-sense prison cell is designed to stop us doing. Gates, Fauci, Whitty, Vallance, Zuckerberg, Brin, Page, Wojcicki, Bezos, and all the others behind the 'Covid' hoax clearly have a long wait before their range of frequency can make that connection given that an open heart is

crucial to that as we shall see. Instead of accessing knowledge directly through expanded awareness it is given to Cult operatives by the secret society networks of the Cult where it has been passed on over thousands of years outside the public arena. Expanded realms of consciousness is where great artists, composers and writers find their inspiration and where truth awaits anyone open enough to connect with it. We need to go there fast.

## **Archon hijack**

A fifth of the Nag Hammadi texts describe the existence and manipulation of the Archons led by a 'Chief Archon' they call 'Yaldabaoth', or the 'Demiurge', and this is the Christian 'Devil', 'Satan', 'Lucifer', and his demons. Archons in Biblical symbolism are the 'fallen ones' which are also referred to as fallen angels after the angels expelled from heaven according to the Abrahamic religions of Judaism, Christianity and Islam. These angels are claimed to tempt humans to 'sin' ongoing and you will see how accurate that symbolism is during the rest of the book. The theme of 'original sin' is related to the 'Fall' when Adam and Eve were 'tempted by the serpent' and fell from a state of innocence and 'obedience' (connection) with God into a state of disobedience (disconnection). The Fall is said to have brought sin into the world and corrupted everything including human nature. Yaldabaoth, the 'Lord Archon', is described by Gnostics as a 'counterfeit spirit', 'The Blind One', 'The Blind God', and 'The Foolish One'. The Jewish name for Yaldabaoth in Talmudic writings is Samael which translates as 'Poison of God', or 'Blindness of God'. You see the parallels. Yaldabaoth in Islamic belief is the Muslim Jinn devil known as Shaytan – Shaytan is Satan as the same themes are found all over the world in every religion and culture. The 'Lord God' of the Old Testament is the 'Lord Archon' of Gnostic manuscripts and that's why he's such a bloodthirsty bastard. Satan is known by Christians as 'the Demon of Demons' and Gnostics called Yaldabaoth the 'Archon of Archons'. Both are known as 'The Deceiver'. We are talking about the same 'bloke' for sure and these common themes

using different names, storylines and symbolism tell a common tale of the human plight.

Archons are referred to in Nag Hammadi documents as mind parasites, inverters, guards, gatekeepers, detainers, judges, pitiless ones and deceivers. The 'Covid' hoax alone is a glaring example of all these things. The Biblical 'God' is so different in the Old and New Testaments because they are not describing the same phenomenon. The vindictive, angry, hate-filled, 'God' of the Old Testament, known as Yahweh, is Yaldabaoth who is depicted in Cult-dictated popular culture as the 'Dark Lord', 'Lord of Time', Lord (Darth) Vader and Dormammu, the evil ruler of the 'Dark Dimension' trying to take over the 'Earth Dimension' in the Marvel comic movie, *Dr Strange*. Yaldabaoth is both the Old Testament 'god' and the Biblical 'Satan'. Gnostics referred to Yaldabaoth as the 'Great Architect of the Universe' and the Cult-controlled Freemason network calls their god 'the 'Great Architect of the Universe' (also Grand Architect). The 'Great Architect' Yaldabaoth is symbolised by the Cult as the all-seeing eye at the top of the pyramid on the Great Seal of the United States and the dollar bill. Archon is encoded in *arch*-itect as it is in *arch*-angels and *arch*-bishops. All religions have the theme of a force for good and force for evil in some sort of spiritual war and there is a reason for that – the theme is true. The Cult and its non-human masters are quite happy for this to circulate. They present themselves as the force for good fighting evil when they are really the force of evil (absence of love). The whole foundation of Cult modus operandi is inversion. They promote themselves as a force for good and anyone challenging them in pursuit of peace, love, fairness, truth and justice is condemned as a satanic force for evil. This has been the game plan throughout history whether the Church of Rome inquisitions of non-believers or 'conspiracy theorists' and 'anti-vaxxers' of today. The technique is the same whatever the timeline era.

**Yaldabaoth is revolting (true)**

Yaldabaoth and the Archons are said to have revolted against God with Yaldabaoth claiming to *be* God – the *All That Is*. The Old Testament ‘God’ (Yaldabaoth) demanded to be worshipped as such: ‘*I am the LORD, and there is none else, there is no God beside me*’ (Isaiah 45:5). I have quoted in other books a man who said he was the unofficial son of the late Baron Philippe de Rothschild of the Mouton-Rothschild wine producing estates in France who died in 1988 and he told me about the Rothschild ‘revolt from God’. The man said he was given the name Phillip Eugene de Rothschild and we shared long correspondence many years ago while he was living under another identity. He said that he was conceived through ‘occult incest’ which (within the Cult) was ‘normal and to be admired’. ‘Phillip’ told me about his experience attending satanic rituals with rich and famous people whom he names and you can see them and the wider background to Cult Satanism in my other books starting with *The Biggest Secret*. Cult rituals are interactions with Archontic ‘gods’. ‘Phillip’ described Baron Philippe de Rothschild as ‘a master Satanist and hater of God’ and he used the same term ‘revolt from God’ associated with Yaldabaoth/Satan/Lucifer/the Devil in describing the Sabbatian Rothschild dynasty. ‘I played a key role in my family’s revolt from God’, he said. That role was to infiltrate in classic Sabbatian style the Christian Church, but eventually he escaped the mind-prison to live another life. The Cult has been targeting religion in a plan to make worship of the Archons the global one-world religion. Infiltration of Satanism into modern ‘culture’, especially among the young, through music videos, stage shows and other means, is all part of this.

Nag Hammadi texts describe Yaldabaoth and the Archons in their prime form as energy – consciousness – and say they can take form if they choose in the same way that consciousness takes form as a human. Yaldabaoth is called ‘formless’ and represents a deeply inverted, distorted and chaotic state of consciousness which seeks to attach to humans and turn them into a likeness of itself in an attempt at assimilation. For that to happen it has to manipulate

humans into low frequency mental and emotional states that match its own. Archons can certainly appear in human form and this is the origin of the psychopathic personality. The energetic distortion Gnostics called Yaldabaoth is psychopathy. When psychopathic Archons take human form that human will be a psychopath as an expression of Yaldabaoth consciousness. Cult psychopaths are Archons in human form. The principle is the same as that portrayed in the 2009 *Avatar* movie when the American military travelled to a fictional Earth-like moon called Pandora in the Alpha Centauri star system to infiltrate a society of blue people, or Na'vi, by hiding within bodies that looked like the Na'vi. Archons posing as humans have a particular hybrid information field, part human, part Archon, (the ancient 'demigods') which processes information in a way that manifests behaviour to match their psychopathic evil, lack of empathy and compassion, and stops them being influenced by the empathy, compassion and love that a fully-human information field is capable of expressing. Cult bloodlines interbreed, be they royalty or dark suits, for this reason and you have their obsession with incest. Interbreeding with full-blown humans would dilute the Archontic energy field that guarantees psychopathy in its representatives in the human realm.

Gnostic writings say the main non-human forms that Archons take are *serpentine* (what I have called for decades 'reptilian' amid unbounded ridicule from the Archontically-programmed) and what Gnostics describe as 'an unborn baby or foetus with grey skin and dark, unmoving eyes'. This is an excellent representation of the ET 'Greys' of UFO folklore which large numbers of people claim to have seen and been abducted by – Zulu shaman Credo Mutwa among them. I agree with those that believe in extraterrestrial or interdimensional visitations today and for thousands of years past. No wonder with their advanced knowledge and technological capability they were perceived and worshipped as gods for technological and other 'miracles' they appeared to perform. Imagine someone arriving in a culture disconnected from the modern world with a smartphone and computer. They would be

seen as a 'god' capable of 'miracles'. The Renegade Mind, however, wants to know the source of everything and not only the way that source manifests as human or non-human. In the same way that a Renegade Mind seeks the original source material for the 'Covid virus' to see if what is claimed is true. The original source of Archons in form is consciousness – the distorted state of consciousness known to Gnostics as Yaldabaoth.

### **'Revolt from God' is energetic disconnection**

Where I am going next will make a lot of sense of religious texts and ancient legends relating to 'Satan', Lucifer' and the 'gods'. Gnostic descriptions sync perfectly with the themes of my own research over the years in how they describe a consciousness distortion seeking to impose itself on human consciousness. I've referred to the core of infinite awareness in previous books as Infinite Awareness in Awareness of Itself. By that I mean a level of awareness that knows that it is all awareness and is aware of all awareness. From here comes the frequency of love in its true sense and balance which is what love is on one level – the balance of all forces into a single whole called Oneness and Isness. The more we disconnect from this state of love that many call 'God' the constituent parts of that Oneness start to unravel and express themselves as a part and not a whole. They become individualised as intellect, mind, selfishness, hatred, envy, desire for power over others, and such like. This is not a problem in the greater scheme in that 'God', the *All That Is*, can experience all these possibilities through different expressions of itself including humans. What we as expressions of the whole experience the *All That Is* experiences. We are the *All That Is* experiencing itself. As we withdraw from that state of Oneness we disconnect from its influence and things can get very unpleasant and very stupid. Archontic consciousness is at the extreme end of that. It has so disconnected from the influence of Oneness that it has become an inversion of unity and love, an inversion of everything, an inversion of life itself. Evil is appropriately live written backwards. Archontic consciousness is obsessed with death, an inversion of life,



and so its manifestations in Satanism are obsessed with death. They use inverted symbols in their rituals such as the inverted pentagram and cross. Sabbatians as Archontic consciousness incarnate invert Judaism and every other religion and culture they infiltrate. They seek disunity and chaos and they fear unity and harmony as they fear love like garlic to a vampire. As a result the Cult, Archons incarnate, act with such evil, psychopathy and lack of empathy and compassion disconnected as they are from the source of love. How could Bill Gates and the rest of the Archontic psychopaths do what they have to human society in the 'Covid' era with all the death, suffering and destruction involved and have no emotional consequence for the impact on others? Now you know. Why have Zuckerberg, Brin, Page, Wojcicki and company callously censored information warning about the dangers of the 'vaccine' while thousands have been dying and having severe, sometimes life-changing reactions? Now you know. Why have Tedros, Fauci, Whitty, Vallance and their like around the world been using case and death figures they're aware are fraudulent to justify lockdowns and all the deaths and destroyed lives that have come from that? Now you know. Why did Christian Drosten produce and promote a 'testing' protocol that he knew couldn't test for infectious disease which led to a global human catastrophe. Now you know. The Archontic mind doesn't give a shit ([Fig 17](#)). I personally think that Gates and major Cult insiders are a form of AI cyborg that the Archons want humans to become.

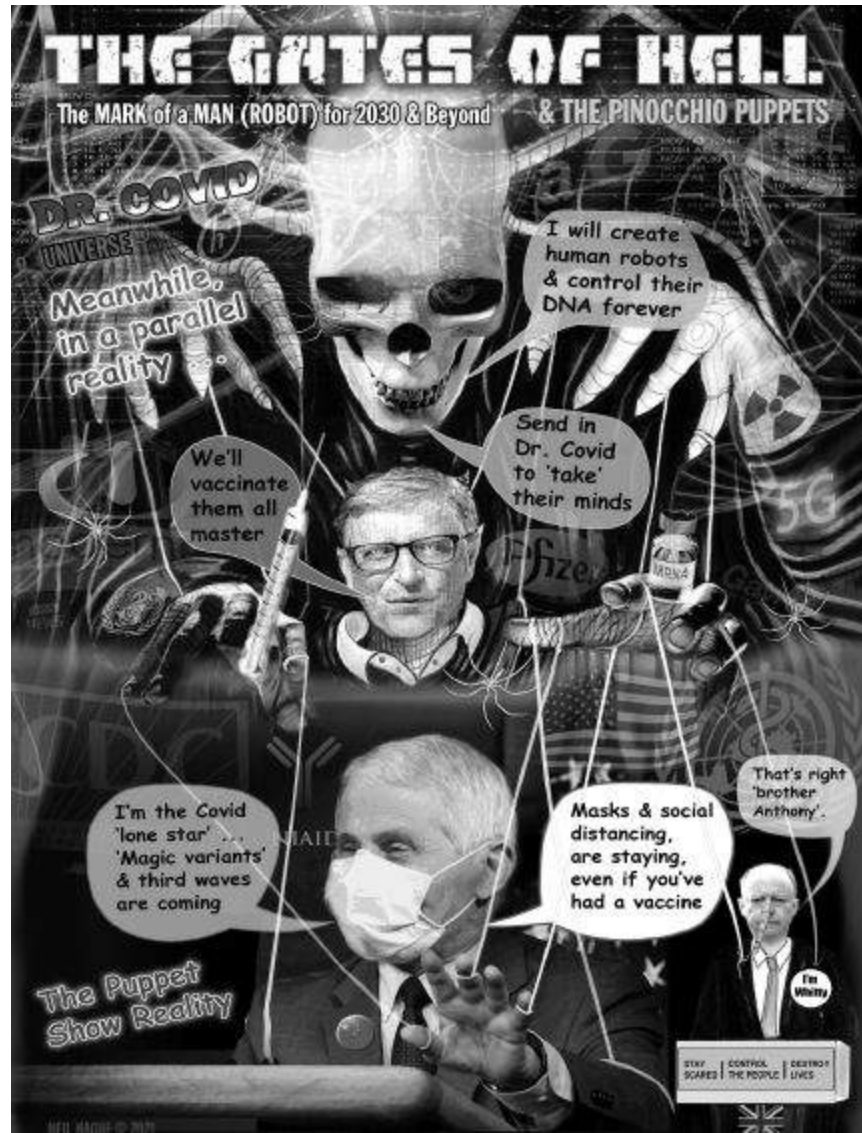


Figure 17: Artist Neil Hague's version of the 'Covid' hierarchy.

## Human batteries

A state of such inversion does have its consequences, however. The level of disconnection from the Source of All means that you withdraw from that source of energetic sustenance and creativity. This means that you have to find your own supply of energetic power and it has – us. When the Morpheus character in the first *Matrix* movie held up a battery he spoke a profound truth when he said: 'The Matrix is a computer-generated dream world built to keep us under control in order to change the human being into one of

these.’ The statement was true in all respects. We do live in a technologically-generated virtual reality simulation (more very shortly) and we have been manipulated to be an energy source for Archontic consciousness. The Disney-Pixar animated movie *Monsters, Inc.* in 2001 symbolised the dynamic when monsters in their world had no energy source and they would enter the human world to terrify children in their beds, catch the child’s scream, terror (low-vibrational frequencies), and take that energy back to power the monster world. The lead character you might remember was a single giant eye and the symbolism of the Cult’s all-seeing eye was obvious. Every thought and emotion is broadcast as a frequency unique to that thought and emotion. Feelings of love and joy, empathy and compassion, are high, quick, frequencies while fear, depression, anxiety, suffering and hate are low, slow, dense frequencies. Which kind do you think Archontic consciousness can connect with and absorb? In such a low and dense frequency state there’s no way it can connect with the energy of love and joy. Archons can only feed off energy compatible with their own frequency and they and their Cult agents want to delete the human world of love and joy and manipulate the transmission of low vibrational frequencies through low-vibrational human mental and emotional states. *We are their energy source.* Wars are energetic banquets to the Archons – a world war even more so – and think how much low-frequency mental and emotional energy has been generated from the consequences for humanity of the ‘Covid’ hoax orchestrated by Archons incarnate like Gates.

The ancient practice of human sacrifice ‘to the gods’, continued in secret today by the Cult, is based on the same principle. ‘The gods’ are Archontic consciousness in different forms and the sacrifice is induced into a state of intense terror to generate the energy the Archontic frequency can absorb. Incarnate Archons in the ritual drink the blood which contains an adrenaline they crave which floods into the bloodstream when people are terrorised. Most of the sacrifices, ancient and modern, are children and the theme of ‘sacrificing young virgins to the gods’ is just code for children. They

have a particular pre-puberty energy that Archons want more than anything and the energy of the young in general is their target. The California Department of Education wants students to chant the names of Aztec gods (Archontic gods) once worshipped in human sacrifice rituals in a curriculum designed to encourage them to 'challenge racist, bigoted, discriminatory, imperialist/colonial beliefs', join 'social movements that struggle for social justice', and 'build new possibilities for a post-racist, post-systemic racism society'. It's the usual Woke crap that inverts racism and calls it anti-racism. In this case solidarity with 'indigenous tribes' is being used as an excuse to chant the names of 'gods' to which people were sacrificed (and still are in secret). What an example of Woke's inability to see beyond black and white, us and them, They condemn the colonisation of these tribal cultures by Europeans (quite right), but those cultures sacrificing people including children to their 'gods', and mass murdering untold numbers as the Aztecs did, is just fine. One chant is to the Aztec god Tezcatlipoca who had a man sacrificed to him in the 5th month of the Aztec calendar. His heart was cut out and he was eaten. Oh, that's okay then. Come on children ... after three ... Other sacrificial 'gods' for the young to chant their allegiance include Quetzalcoatl, Huitzilopochtli and Xipe Totec. The curriculum says that 'chants, affirmations, and energizers can be used to bring the class together, build unity around ethnic studies principles and values, and to reinvigorate the class following a lesson that may be emotionally taxing or even when student engagement may appear to be low'. Well, that's the cover story, anyway. Chanting and mantras are the repetition of a particular frequency generated from the vocal cords and chanting the names of these Archontic 'gods' tunes you into their frequency. That is the last thing you want when it allows for energetic synchronisation, attachment and perceptual influence. Initiates chant the names of their 'Gods' in their rituals for this very reason.

## **Vampires of the Woke**

Paedophilia is another way that Archons absorb the energy of children. Paedophiles possessed by Archontic consciousness are used as the conduit during sexual abuse for discarnate Archons to vampire the energy of the young they desire so much. Stupendous numbers of children disappear every year never to be seen again although you would never know from the media. Imagine how much low-vibrational energy has been generated by children during the 'Covid' hoax when so many have become depressed and psychologically destroyed to the point of killing themselves. Shocking numbers of children are now taken by the state from loving parents to be handed to others. I can tell you from long experience of researching this since 1996 that many end up with paedophiles and assets of the Cult through corrupt and Cult-owned social services which in the reframing era has hired many psychopaths and emotionless automatons to do the job. Children are even stolen to order using spurious reasons to take them by the corrupt and secret (because they're corrupt) 'family courts'. I have written in detail in other books, starting with *The Biggest Secret* in 1997, about the ubiquitous connections between the political, corporate, government, intelligence and military elites (Cult operatives) and Satanism and paedophilia. If you go deep enough both networks have an interlocking leadership. The Woke mentality has been developed by the Cult for many reasons: To promote almost every aspect of its agenda; to hijack the traditional political left and turn it fascist; to divide and rule; and to target agenda pushbackers. But there are other reasons which relate to what I am describing here. How many happy and joyful Wokers do you ever see especially at the extreme end? They are a mental and psychological mess consumed by emotional stress and constantly emotionally cocked for the next explosion of indignation at someone referring to a female as a female. They are walking, talking, batteries as Morpheus might say emitting frequencies which both enslave them in low-vibrational bubbles of perceptual limitation and feed the Archons. Add to this the hatred claimed to be love; fascism claimed to 'anti-fascism', racism claimed to be 'anti-racism';

exclusion claimed to inclusion; and the abuse-filled Internet trolling. You have a purpose-built Archontic energy system with not a wind turbine in sight and all founded on Archontic *inversion*. We have whole generations now manipulated to serve the Archons with their actions and energy. They will be doing so their entire adult lives unless they snap out of their Archon-induced trance. Is it really a surprise that Cult billionaires and corporations put so much money their way? Where is the energy of joy and laughter, including laughing at yourself which is confirmation of your own emotional security? Mark Twain said: 'The human race has one really effective weapon, and that is laughter.' We must use it all the time. Woke has destroyed comedy because it has no humour, no joy, sense of irony, or self-deprecation. Its energy is dense and intense. *Mmmmm*, lunch says the Archontic frequency. Rudolf Steiner (1861-1925) was the Austrian philosopher and famous esoteric thinker who established Waldorf education or Steiner schools to treat children like unique expressions of consciousness and not minds to be programmed with the perceptions determined by authority. I'd been writing about this energy vampiring for decades when I was sent in 2016 a quote by Steiner. He was spot on:

There are beings in the spiritual realms for whom anxiety and fear emanating from human beings offer welcome food. When humans have no anxiety and fear, then these creatures starve. If fear and anxiety radiates from people and they break out in panic, then these creatures find welcome nutrition and they become more and more powerful. These beings are hostile towards humanity. Everything that feeds on negative feelings, on anxiety, fear and superstition, despair or doubt, are in reality hostile forces in super-sensible worlds, launching cruel attacks on human beings, while they are being fed ... These are exactly the feelings that belong to contemporary culture and materialism; because it estranges people from the spiritual world, it is especially suited to evoke hopelessness and fear of the unknown in people, thereby calling up the above mentioned hostile forces against them.

Pause for a moment from this perspective and reflect on what has happened in the world since the start of 2020. Not only will pennies drop, but billion dollar bills. We see the same theme from Don Juan Matus, a Yaqui Indian shaman in Mexico and the information source for Peruvian-born writer, Carlos Castaneda, who wrote a series of

books from the 1960s to 1990s. Don Juan described the force manipulating human society and his name for the Archons was the predator:

We have a predator that came from the depths of the cosmos and took over the rule of our lives. Human beings are its prisoners. The predator is our lord and master. It has rendered us docile, helpless. If we want to protest, it suppresses our protest. If we want to act independently, it demands that we don't do so ... indeed we are held prisoner!

They took us over because we are food to them, and they squeeze us mercilessly because we are their sustenance. Just as we rear chickens in coops, the predators rear us in human coops, humaneros. Therefore, their food is always available to them.

Different cultures, different eras, same recurring theme.

## **The 'ennoia' dilemma**

Nag Hammadi Gnostic manuscripts say that Archon consciousness has no 'ennoia'. This is directly translated as 'intentionality', but I'll use the term 'creative imagination'. The *All That Is* in awareness of itself is the source of all creativity – all possibility – and the more disconnected you are from that source the more you are subsequently denied 'creative imagination'. Given that Archon consciousness is almost entirely disconnected it severely lacks creativity and has to rely on far more mechanical processes of thought and exploit the creative potential of those that do have 'ennoia'. You can see cases of this throughout human society. Archon consciousness almost entirely dominates the global banking system and if we study how that system works you will appreciate what I mean. Banks manifest 'money' out of nothing by issuing lines of 'credit' which is 'money' that has never, does not, and will never exist except in theory. It's a confidence trick. If you think 'credit' figures-on-a-screen 'money' is worth anything you accept it as payment. If you don't then the whole system collapses through lack of confidence in the value of that 'money'. Archontic bankers with no 'ennoia' are 'lending' 'money' that doesn't exist to humans that *do* have creativity – those that have the inspired ideas and create businesses and products. Archon banking feeds off human creativity

which it controls through 'money' creation and debt. Humans have the creativity and Archons exploit that for their own benefit and control while having none themselves. Archon Internet platforms like Facebook claim joint copyright of everything that creative users post and while Archontic minds like Zuckerberg may officially head that company it will be human creatives on the staff that provide the creative inspiration. When you have limitless 'money' you can then buy other companies established by creative humans. Witness the acquisition record of Facebook, Google and their like. Survey the Archon-controlled music industry and you see non-creative dark suit executives making their fortune from the human creativity of their artists. The cases are endless. Research the history of people like Gates and Zuckerberg and how their empires were built on exploiting the creativity of others. Archon minds cannot create out of nothing, but they are skilled (because they have to be) in what Gnostic texts call 'countermimicry'. They can imitate, but not innovate. Sabbatians trawl the creativity of others through backdoors they install in computer systems through their cybersecurity systems. Archon-controlled China is globally infamous for stealing intellectual property and I remember how Hong Kong, now part of China, became notorious for making counterfeit copies of the creativity of others – 'countermimicry'. With the now pervasive and all-seeing surveillance systems able to infiltrate any computer you can appreciate the potential for Archons to vampire the creativity of humans. Author John Lamb Lash wrote in his book about the Nag Hammadi texts, *Not In His Image*:

Although they cannot originate anything, because they lack the divine factor of ennoia (intentionality), Archons can imitate with a vengeance. Their expertise is simulation (HAL, virtual reality). The Demiurge [Yaldabaoth] fashions a heaven world copied from the fractal patterns [of the original] ... His construction is celestial kitsch, like the fake Italianate villa of a Mafia don complete with militant angels to guard every portal.

This brings us to something that I have been speaking about since the turn of the millennium. Our reality is a simulation; a virtual reality that we think is real. No, I'm not kidding.



## **Human reality? Well, virtually**

I had pondered for years about whether our reality is 'real' or some kind of construct. I remembered being immensely affected on a visit as a small child in the late 1950s to the then newly-opened Planetarium on the Marylebone Road in London which is now closed and part of the adjacent Madame Tussauds wax museum. It was in the middle of the day, but when the lights went out there was the night sky projected in the Planetarium's domed ceiling and it appeared to be so real. The experience never left me and I didn't know why until around the turn of the millennium when I became certain that our 'night sky' and entire reality is a projection, a virtual reality, akin to the illusory world portrayed in the *Matrix* movies. I looked at the sky one day in this period and it appeared to me like the domed roof of the Planetarium. The release of the first *Matrix* movie in 1999 also provided a synchronistic and perfect visual representation of where my mind had been going for a long time. I hadn't come across the Gnostic Nag Hammadi texts then. When I did years later the correlation was once again astounding. As I read Gnostic accounts from 1,600 years and more earlier it was clear that they were describing the same simulation phenomenon. They tell how the Yaldabaoth 'Demiurge' and Archons created a 'bad copy' of original reality to rule over all that were captured by its illusions and the body was a prison to trap consciousness in the 'bad copy' fake reality. Read how Gnostics describe the 'bad copy' and update that to current times and they are referring to what we would call today a virtual reality simulation.

Author John Lamb Lash said 'the Demiurge fashions a heaven world copied from the fractal patterns' of the original through expertise in 'HAL' or virtual reality simulation. Fractal patterns are part of the energetic information construct of our reality, a sort of blueprint. If these patterns were copied in computer terms it would indeed give you a copy of a 'natural' reality in a non-natural frequency and digital form. The principle is the same as making a copy of a website. The original website still exists, but now you can change the copy version to make it whatever you like and it can

become very different to the original website. Archons have done this with our reality, a *synthetic* copy of prime reality that still exists beyond the frequency walls of the simulation. Trapped within the illusions of this synthetic Matrix, however, were and are human consciousness and other expressions of prime reality and this is why the Archons via the Cult are seeking to make the human body synthetic and give us synthetic AI minds to complete the job of turning the entire reality synthetic including what we perceive to be the natural world. To quote Kurzweil: 'Nanobots will infuse all the matter around us with information. Rocks, trees, everything will become these intelligent creatures.' Yes, *synthetic* 'creatures' just as 'Covid' and other genetically-manipulating 'vaccines' are designed to make the human body synthetic. From this perspective it is obvious why Archons and their Cult are so desperate to infuse synthetic material into every human with their 'Covid' scam.

### **Let there be (electromagnetic) light**

Yaldabaoth, the force that created the simulation, or Matrix, makes sense of the Gnostic reference to 'The Great Architect' and its use by Cult Freemasonry as the name of its deity. The designer of the Matrix in the movies is called 'The Architect' and that trilogy is jam-packed with symbolism relating to these subjects. I have contended for years that the angry Old Testament God (Yaldabaoth) is the 'God' being symbolically 'quoted' in the opening of Genesis as 'creating the world'. This is not the creation of prime reality – it's the creation of the *simulation*. The Genesis 'God' says: 'Let there be Light: and there was light.' But what is this 'Light'? I have said for decades that the speed of light (186,000 miles per second) is not the fastest speed possible as claimed by mainstream science and is in fact the frequency walls or outer limits of the Matrix. You can't have a fastest or slowest anything within all possibility when everything is possible. The human body is encoded to operate within the speed of light or *within the simulation* and thus we see only the tiny frequency band of visible *light*. Near-death experiencers who perceive reality outside the body during temporary 'death' describe a very different

form of light and this is supported by the Nag Hammadi texts. Prime reality beyond the simulation ('Upper Aeons' to the Gnostics) is described as a realm of incredible beauty, bliss, love and harmony – a realm of 'watery light' that is so powerful 'there are no shadows'. Our false reality of Archon control, which Gnostics call the 'Lower Aeons', is depicted as a realm with a different kind of 'light' and described in terms of chaos, 'Hell', 'the Abyss' and 'Outer Darkness', where trapped souls are tormented and manipulated by demons (relate that to the 'Covid' hoax alone). The watery light theme can be found in near-death accounts and it is not the same as *simulation* 'light' which is electromagnetic or radiation light within the speed of light – the 'Lower Aeons'. Simulation 'light' is the 'luminous fire' associated by Gnostics with the Archons. The Bible refers to Yaldabaoth as 'that old serpent, called the Devil, and Satan, which deceiveth the whole world' (Revelation 12:9). I think that making a simulated copy of prime reality ('countermimicry') and changing it dramatically while all the time manipulating humanity to believe it to be real could probably meet the criteria of deceiving the whole world. Then we come to the Cult god Lucifer – the *Light Bringer*. Lucifer is symbolic of Yaldabaoth, the bringer of radiation light that forms the bad copy simulation within the speed of light. 'He' is symbolised by the lighted torch held by the Statue of Liberty and in the name 'Illuminati'. Sabbatian-Frankism declares that Lucifer is the true god and Lucifer is the real god of Freemasonry honoured as their 'Great or Grand Architect of the Universe' (simulation).

I would emphasise, too, the way Archontic technologically-generated luminous fire of radiation has deluged our environment since I was a kid in the 1950s and changed the nature of The Field with which we constantly interact. Through that interaction technological radiation is changing us. The Smart Grid is designed to operate with immense levels of communication power with 5G expanding across the world and 6G, 7G, in the process of development. Radiation is the simulation and the Archontic manipulation system. Why wouldn't the Archon Cult wish to unleash radiation upon us to an ever-greater extreme to form

Kurzweil's 'cloud'? The plan for a synthetic human is related to the need to cope with levels of radiation beyond even anything we've seen so far. Biological humans would not survive the scale of radiation they have in their script. The Smart Grid is a technological sub-reality within the technological simulation to further disconnect five-sense perception from expanded consciousness. It's a technological prison of the mind.

### **Infusing the 'spirit of darkness'**

A recurring theme in religion and native cultures is the manipulation of human genetics by a non-human force and most famously recorded as the biblical 'sons of god' (the gods plural in the original) who interbred with the daughters of men. The Nag Hammadi *Apocryphon of John* tells the same story this way:

He [Yaldabaoth] sent his angels [Archons/demons] to the daughters of men, that they might take some of them for themselves and raise offspring for their enjoyment. And at first they did not succeed. When they had no success, they gathered together again and they made a plan together ... And the angels changed themselves in their likeness into the likeness of their mates, filling them with the spirit of darkness, which they had mixed for them, and with evil ... And they took women and begot children out of the darkness according to the likeness of their spirit.

Possession when a discarnate entity takes over a human body is an age-old theme and continues today. It's very real and I've seen it. Satanic and secret society rituals can create an energetic environment in which entities can attach to initiates and I've heard many stories of how people have changed their personality after being initiated even into lower levels of the Freemasons. I have been inside three Freemasonic temples, one at a public open day and two by just walking in when there was no one around to stop me. They were in Ryde, the town where I live, Birmingham, England, when I was with a group, and Boston, Massachusetts. They all felt the same energetically – dark, dense, low-vibrational and sinister. Demonic attachment can happen while the initiate has no idea what is going on. To them it's just a ritual to get in the Masons and do a bit of good

business. In the far more extreme rituals of Satanism human possession is even more powerful and they are designed to make possession possible. The hierarchy of the Cult is dictated by the power and perceived status of the possessing Archon. In this way the Archon hierarchy becomes the Cult hierarchy. Once the entity has attached it can influence perception and behaviour and if it attaches to the extreme then so much of its energy (information) infuses into the body information field that the hologram starts to reflect the nature of the possessing entity. This is the *Exorcist* movie type of possession when facial features change and it's known as shapeshifting. Islam's Jinn are said to be invisible tricksters who change shape, 'whisper', confuse and take human form. These are all traits of the Archons and other versions of the same phenomenon. Extreme possession could certainly infuse the 'spirit of darkness' into a partner during sex as the Nag Hammadi texts appear to describe. Such an infusion can change genetics which is also energetic information. Human genetics is information and the 'spirit of darkness' is information. Mix one with the other and change must happen. Islam has the concept of a 'Jinn baby' through possession of the mother and by Jinn taking human form. There are many ways that human genetics can be changed and remember that Archons have been aware all along of advanced techniques to do this. What is being done in human society today – and far more – was known about by Archons at the time of the 'fallen ones' and their other versions described in religions and cultures.

Archons and their human-world Cult are obsessed with genetics as we see today and they know this dictates how information is processed into perceived reality during a human life. They needed to produce a human form that would decode the simulation and this is symbolically known as 'Adam and Eve' who left the 'garden' (prime reality) and 'fell' into Matrix reality. The simulation is not a 'physical' construct (there is no 'physical'); it is a source of information. Think Wi-Fi again. The simulation is an energetic field encoded with information and body-brain systems are designed to decode that information encoded in wave or frequency form which

is transmitted to the brain as electrical signals. These are decoded by the brain to construct our sense of reality – an illusory ‘physical’ world that only exists in the brain or the mind. Virtual reality games mimic this process using the same sensory decoding system. Information is fed to the senses to decode a virtual reality that can appear so real, but isn’t (Figs 18 and 19). Some scientists believe – and I agree with them – that what we perceive as ‘physical’ reality only exists when we are looking or observing. The act of perception or focus triggers the decoding systems which turn waveform information into holographic reality. When we are not observing something our reality reverts from a holographic state to a waveform state. This relates to the same principle as a falling tree not making a noise unless someone is there to hear it or decode it. The concept makes sense from the simulation perspective. A computer is not decoding all the information in a Wi-Fi field all the time and only decodes or brings into reality on the screen that part of Wi-Fi that it’s decoding – focusing upon – at that moment.



**Figure 18:** Virtual reality technology ‘hacks’ into the body’s five-sense decoding system.



**Figure 19:** The result can be experienced as very ‘real’.

Interestingly, Professor Donald Hoffman at the Department of Cognitive Sciences at the University of California, Irvine, says that our experienced reality is like a computer interface that shows us only the level with which we interact while hiding all that exists beyond it: 'Evolution shaped us with a user interface that hides the truth. Nothing that we see is the truth – the very language of space and time and objects is the wrong language to describe reality.' He is correct in what he says on so many levels. Space and time are not a universal reality. They are a phenomenon of decoded *simulation* reality as part of the process of enslaving our sense of reality. Near-death experiencers report again and again how space and time did not exist as we perceive them once they were free of the body – body decoding systems. You can appreciate from this why Archons and their Cult are so desperate to entrap human attention in the five senses where we are in the Matrix and of the Matrix. Opening your mind to expanded states of awareness takes you beyond the information confines of the simulation and you become aware of knowledge and insights denied to you before. This is what we call 'awakening' – *awakening from the Matrix* – and in the final chapter I will relate this to current events.

## **Where are the 'aliens'?**

A simulation would explain the so-called 'Fermi Paradox' named after Italian physicist Enrico Fermi (1901-1954) who created the first nuclear reactor. He considered the question of why there is such a lack of extraterrestrial activity when there are so many stars and planets in an apparently vast universe; but what if the night sky that we see, or think we do, is a simulated projection as I say? If you control the simulation and your aim is to hold humanity fast in essential ignorance would you want other forms of life including advanced life coming and going sharing information with humanity? Or would you want them to believe they were isolated and apparently alone? Themes of human isolation and apartness are common whether they be the perception of a lifeless universe or the fascist isolation laws of the 'Covid' era. Paradoxically the very

existence of a simulation means that we are not alone when some force had to construct it. My view is that experiences that people have reported all over the world for centuries with Reptilians and Grey entities are Archon phenomena as Nag Hammadi texts describe; and that benevolent 'alien' interactions are non-human groups that come in and out of the simulation by overcoming Archon attempts to keep them out. It should be highlighted, too, that Reptilians and Greys are obsessed with *genetics* and *technology* as related by cultural accounts and those who say they have been abducted by them. Technology is their way of overcoming some of the limitations in their creative potential and our technology-driven and controlled human society of today is *archetypical* Archon-Reptilian-Grey modus operandi. Technocracy is really *Archontocracy*. The Universe does not have to be as big as it appears with a simulation. There is no space or distance only information decoded into holographic reality. What we call 'space' is only the absence of holographic 'objects' and that 'space' is The Field of energetic information which connects everything into a single whole. The same applies with the artificially-generated information field of the simulation. The Universe is not big or small as a physical reality. It is decoded information, that's all, and its perceived size is decided by the way the simulation is encoded to make it appear. The entire night sky as we perceive it only exists in our brain and so where are those 'millions of light years'? The 'stars' on the ceiling of the Planetarium looked a vast distance away.

There's another point to mention about 'aliens'. I have been highlighting since the 1990s the plan to stage a fake 'alien invasion' to justify the centralisation of global power and a world military. Nazi scientist Werner von Braun, who was taken to America by Operation Paperclip after World War Two to help found NASA, told his American assistant Dr Carol Rosin about the Cult agenda when he knew he was dying in 1977. Rosin said that he told her about a sequence that would lead to total human control by a one-world government. This included threats from terrorism, rogue nations, meteors and asteroids before finally an 'alien invasion'. All of these



things, von Braun said, would be bogus and what I would refer to as a No-Problem-Reaction-Solution. Keep this in mind when 'the aliens are coming' is the new mantra. The aliens are not coming – they are *already here* and they have infiltrated human society while looking human. French-Canadian investigative journalist Serge Monast said in 1994 that he had uncovered a NASA/military operation called Project Blue Beam which fits with what Werner von Braun predicted. Monast died of a 'heart attack' in 1996 the day after he was arrested and spent a night in prison. He was 51. He said Blue Beam was a plan to stage an alien invasion that would include religious figures beamed holographically into the sky as part of a global manipulation to usher in a 'new age' of worshipping what I would say is the Cult 'god' Yaldabaoth in a one-world religion. Fake holographic asteroids are also said to be part of the plan which again syncs with von Braun. How could you stage an illusory threat from asteroids unless they were holographic inserts? This is pretty straightforward given the advanced technology outside the public arena and the fact that our 'physical' reality is holographic anyway. Information fields would be projected and we would decode them into the illusion of a 'physical' asteroid. If they can sell a global 'pandemic' with a 'virus' that doesn't exist what will humans not believe if government and media tell them?

All this is particularly relevant as I write with the Pentagon planning to release in June, 2021, information about 'UFO sightings'. I have been following the UFO story since the early 1990s and the common theme throughout has been government and military denials and cover up. More recently, however, the Pentagon has suddenly become more talkative and apparently open with Air Force pilot radar images released of unexplained craft moving and changing direction at speeds well beyond anything believed possible with human technology. Then, in March, 2021, former Director of National Intelligence John Ratcliffe said a Pentagon report months later in June would reveal a great deal of information about UFO sightings unknown to the public. He said the report would have 'massive implications'. The order to do this was included bizarrely

in a \$2.3 trillion 'coronavirus' relief and government funding bill passed by the Trump administration at the end of 2020. I would add some serious notes of caution here. I have been pointing out since the 1990s that the US military and intelligence networks have long had craft – 'flying saucers' or anti-gravity craft – which any observer would take to be extraterrestrial in origin. Keeping this knowledge from the public allows craft flown by *humans* to be perceived as alien visitations. I am not saying that 'aliens' do not exist. I would be the last one to say that, but we have to be streetwise here. President Ronald Reagan told the UN General Assembly in 1987: 'I occasionally think how quickly our differences worldwide would vanish if we were facing an alien threat from outside this world.' That's the idea. Unite against a common 'enemy' with a common purpose behind your 'saviour force' (the Cult) as this age-old technique of mass manipulation goes global.

### **Science moves this way ...**

I could find only one other person who was discussing the simulation hypothesis publicly when I concluded it was real. This was Nick Bostrom, a Swedish-born philosopher at the University of Oxford, who has explored for many years the possibility that human reality is a computer simulation although his version and mine are not the same. Today the simulation and holographic reality hypothesis have increasingly entered the scientific mainstream. Well, the more open-minded mainstream, that is. Here are a few of the ever-gathering examples. American nuclear physicist Silas Beane led a team of physicists at the University of Bonn in Germany pursuing the question of whether we live in a simulation. They concluded that we probably do and it was likely based on a lattice of cubes. They found that cosmic rays align with that specific pattern. The team highlighted the Greisen–Zatsepin–Kuzmin (GZK) limit which refers to cosmic ray particle interaction with cosmic background radiation that creates an apparent boundary for cosmic ray particles. They say in a paper entitled 'Constraints on the Universe as a Numerical Simulation' that this 'pattern of constraint' is exactly what you

would find with a computer simulation. They also made the point that a simulation would create its own 'laws of physics' that would limit possibility. I've been making the same point for decades that the *perceived* laws of physics relate only to this reality, or what I would later call the simulation. When designers write codes to create computer and virtual reality games they are the equivalent of the laws of physics for that game. Players interact within the limitations laid out by the coding. In the same way those who wrote the codes for the simulation decided the laws of physics that would apply. These can be overridden by expanded states of consciousness, but not by those enslaved in only five-sense awareness where simulation codes rule. Overriding the codes is what people call 'miracles'. They are not. They are bypassing the encoded limits of the simulation. A population caught in simulation perception would have no idea that this was their plight. As the Bonn paper said: 'Like a prisoner in a pitch-black cell we would not be able to see the "walls" of our prison,' That's true if people remain mesmerised by the five senses. Open to expanded awareness and those walls become very clear. The main one is the speed of light.

American theoretical physicist James Gates is another who has explored the simulation question and found considerable evidence to support the idea. Gates was Professor of Physics at the University of Maryland, Director of The Center for String and Particle Theory, and on Barack Obama's Council of Advisors on Science and Technology. He and his team found *computer codes* of digital data embedded in the fabric of our reality. They relate to on-off electrical charges of 1 and 0 in the binary system used by computers. 'We have no idea what they are doing there', Gates said. They found within the energetic fabric mathematical sequences known as error-correcting codes or block codes that 'reboot' data to its original state or 'default settings' when something knocks it out of sync. Gates was asked if he had found a set of equations embedded in our reality indistinguishable from those that drive search engines and browsers and he said: 'That is correct.' Rich Terrile, director of the Centre for Evolutionary Computation and Automated Design at NASA's Jet

Propulsion Laboratory, has said publicly that he believes the Universe is a digital hologram that must have been created by a form of intelligence. I agree with that in every way. Waveform information is delivered electrically by the senses to the brain which constructs a *digital* holographic reality that we call the 'world'. This digital level of reality can be read by the esoteric art of numerology. Digital holograms are at the cutting edge of holographics today. We have digital technology everywhere designed to access and manipulate our digital level of perceived reality. Synthetic mRNA in 'Covid vaccines' has a digital component to manipulate the body's digital 'operating system'.

## **Reality is numbers**

How many know that our reality can be broken down to numbers and codes that are the same as computer games? Max Tegmark, a physicist at the Massachusetts Institute of Technology (MIT), is the author of *Our Mathematical Universe* in which he lays out how reality can be entirely described by numbers and maths in the way that a video game is encoded with the 'physics' of computer games. Our world and computer virtual reality are essentially the same.

Tegmark imagines the perceptions of characters in an advanced computer game when the graphics are so good they don't know they are in a game. They think they can bump into real objects (electromagnetic resistance in our reality), fall in love and feel emotions like excitement. When they began to study the apparently 'physical world' of the video game they would realise that everything was made of pixels (which have been found in our energetic reality as must be the case when on one level our world is digital). What computer game characters thought was physical 'stuff', Tegmark said, could actually be broken down into numbers:

And we're exactly in this situation in our world. We look around and it doesn't seem that mathematical at all, but everything we see is made out of elementary particles like quarks and electrons. And what properties does an electron have? Does it have a smell or a colour or a texture? No! ... We physicists have come up with geeky names for [Electron] properties, like

electric charge, or spin, or lepton number, but the electron doesn't care what we call it, the properties are just numbers.

This is the illusory reality Gnostics were describing. This is the simulation. The A, C, G, and T codes of DNA have a binary value – A and C = 0 while G and T = 1. This has to be when the simulation is digital and the body must be digital to interact with it. Recurring mathematical sequences are encoded throughout reality and the body. They include the Fibonacci sequence in which the two previous numbers are added to get the next one, as in ... 1, 1, 2, 3, 5, 8, 13, 21, 34, 55, etc. The sequence is encoded in the human face and body, proportions of animals, DNA, seed heads, pine cones, trees, shells, spiral galaxies, hurricanes and the number of petals in a flower. The list goes on and on. There are fractal patterns – a 'never-ending pattern that is infinitely complex and self-similar across all scales in the as above, so below, principle of holograms. These and other famous recurring geometrical and mathematical sequences such as Phi, Pi, Golden Mean, Golden Ratio and Golden Section are *computer codes* of the simulation. I had to laugh and give my head a shake the day I finished this book and it went into the production stage. I was sent an article in *Scientific American* published in April, 2021, with the headline 'Confirmed! We Live in a Simulation'. Two decades after I first said our reality is a simulation and the speed of light is its outer limit the article suggested that we do live in a simulation and that the speed of light is its outer limit. I left school at 15 and never passed a major exam in my life while the writer was up to his eyes in qualifications. As I will explain in the final chapter *knowing* is far better than thinking and they come from very different sources. The article rightly connected the speed of light to the processing speed of the 'Matrix' and said what has been in my books all this time ... 'If we are in a simulation, as it appears, then space is an abstract property written in code. It is not real'. No it's not and if we live in a simulation something created it and it wasn't *us*. 'That David Icke says we are manipulated by aliens' – he's crackers.'

## **Wow ...**

The reality that humanity thinks is so real is an illusion. Politicians, governments, scientists, doctors, academics, law enforcement, media, school and university curriculums, on and on, are all founded on a world that *does not exist* except as a simulated prison cell. Is it such a stretch to accept that 'Covid' doesn't exist when our entire 'physical' reality doesn't exist? Revealed here is the knowledge kept under raps in the Cult networks of compartmentalised secrecy to control humanity's sense of reality by inducing the population to believe in a reality that's not real. If it wasn't so tragic in its experiential consequences the whole thing would be hysterically funny. None of this is new to Renegade Minds. Ancient Greek philosopher Plato (about 428 to about 347BC) was a major influence on Gnostic belief and he described the human plight thousands of years ago with his Allegory of the Cave. He told the symbolic story of prisoners living in a cave who had never been outside. They were chained and could only see one wall of the cave while behind them was a fire that they could not see. Figures walked past the fire casting shadows on the prisoners' wall and those moving shadows became their sense of reality. Some prisoners began to study the shadows and were considered experts on them (today's academics and scientists), but what they studied was only an illusion (today's academics and scientists). A prisoner escaped from the cave and saw reality as it really is. When he returned to report this revelation they didn't believe him, called him mad and threatened to kill him if he tried to set them free. Plato's tale is not only a brilliant analogy of the human plight and our illusory reality. It describes, too, the dynamics of the 'Covid' hoax. I have only skimmed the surface of these subjects here. The aim of this book is to crisply connect all essential dots to put what is happening today into its true context. All subject areas and their connections in this chapter are covered in great evidential detail in *Everything You Need To Know, But Have Never Been Told* and *The Answer*.

They say that bewildered people 'can't see the forest for the trees'. Humanity, however, can't see the forest for the *twigs*. The five senses

see only twigs while Renegade Minds can see the forest and it's the forest where the answers lie with the connections that reveals. Breaking free of perceptual programming so the forest can be seen is the way we turn all this around. Not breaking free is how humanity got into this mess. The situation may seem hopeless, but I promise you it's not. We are a perceptual heartbeat from paradise if only we knew.

## CHAPTER TWELVE

### **Escaping Wetiko**

*Life is simply a vacation from the infinite*

Dean Cavanagh

**R**enegade Minds weave the web of life and events and see common themes in the apparently random. They are always there if you look for them and their pursuit is aided by incredible synchronicity that comes when your mind is open rather than mesmerised by what it thinks it can see.

Infinite awareness is infinite possibility and the more of infinite possibility that we access the more becomes infinitely possible. That may be stating the apparently obvious, but it is a devastatingly-powerful fact that can set us free. We are a point of attention within an infinity of consciousness. The question is how much of that infinity do we choose to access? How much knowledge, insight, awareness, wisdom, do we want to connect with and explore? If your focus is only in the five senses you will be influenced by a fraction of infinite awareness. I mean a range so tiny that it gives new meaning to infinitesimal. Limitation of self-identity and a sense of the possible limit accordingly your range of consciousness. We are what we think we are. Life is what we think it is. The dream is the dreamer and the dreamer is the dream. Buddhist philosophy puts it this way: 'As a thing is viewed, so it appears.' Most humans live in the realm of touch, taste, see, hear, and smell and that's the limit of their sense of the possible and sense of self. Many will follow a religion and speak of a God in his heaven, but their lives are still



dominated by the five senses in their perceptions and actions. The five senses become the arbiter of everything. When that happens all except a smear of infinity is sealed away from influence by the rigid, unyielding, reality bubbles that are the five-sense human or Phantom Self. Archon Cult methodology is to isolate consciousness within five-sense reality – the simulation – and then program that consciousness with a sense of self and the world through a deluge of life-long information designed to instil the desired perception that allows global control. Efforts to do this have increased dramatically with identity politics as identity bubbles are squeezed into the minutiae of five-sense detail which disconnect people even more profoundly from the infinite 'I'.

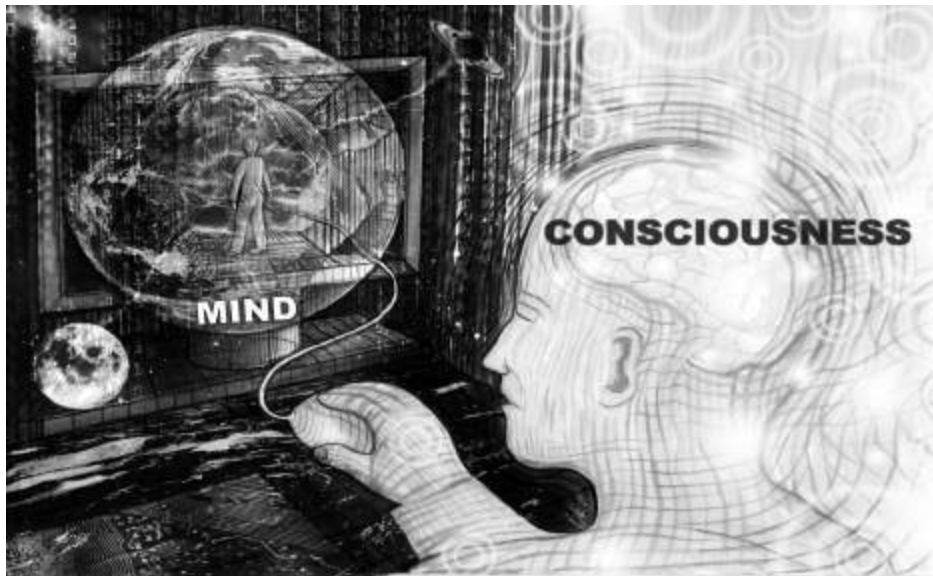
Five-sense focus and self-identity are like a firewall that limits access to the infinite realms. You only perceive one radio or television station and no other. We'll take that literally for a moment. Imagine a vast array of stations giving different information and angles on reality, but you only ever listen to one. Here we have the human plight in which the population is overwhelmingly confined to CultFM. This relates only to the frequency range of CultFM and limits perception and insight to that band – limits *possibility* to that band. It means you are connecting with an almost imperceptibly minuscule range of possibility and creative potential within the infinite Field. It's a world where everything seems apart from everything else and where synchronicity is rare. Synchronicity is defined in the dictionary as 'the happening by chance of two or more related or similar events at the same time'. Use of 'by chance' betrays a complete misunderstanding of reality. Synchronicity is not 'by chance'. As people open their minds, or 'awaken' to use the term, they notice more and more coincidences in their lives, bits of 'luck', apparently miraculous happenings that put them in the right place at the right time with the right people. Days become peppered with 'fancy meeting you here' and 'what are the chances of that?' My entire life has been lived like this and ever more so since my own colossal awakening in 1990 and 91 which transformed my sense of reality. Synchronicity is not 'by chance'; it is by accessing expanded

realms of possibility which allow expanded potential for manifestation. People broadcasting the same vibe from the same openness of mind tend to be drawn 'by chance' to each other through what I call frequency magnetism and it's not only people. In the last more than 30 years incredible synchronicity has also led me through the Cult maze to information in so many forms and to crucial personal experiences. These 'coincidences' have allowed me to put the puzzle pieces together across an enormous array of subjects and situations. Those who have breached the bubble of five-sense reality will know exactly what I mean and this escape from the perceptual prison cell is open to everyone whenever they make that choice. This may appear super-human when compared with the limitations of 'human', but it's really our natural state. 'Human' as currently experienced is consciousness in an unnatural state of induced separation from the infinity of the whole. I'll come to how this transformation into unity can be made when I have described in more detail the force that holds humanity in servitude by denying this access to infinite self.

### **The Wetiko factor**

I have been talking and writing for decades about the way five-sense mind is systematically barricaded from expanded awareness. I have used the analogy of a computer (five-sense mind) and someone at the keyboard (expanded awareness). Interaction between the computer and the operator is symbolic of the interaction between five-sense mind and expanded awareness. The computer directly experiences the Internet and the operator experiences the Internet via the computer which is how it's supposed to be – the two working as one. Archons seek to control that point where the operator connects with the computer to stop that interaction ([Fig 20](#)). Now the operator is banging the keyboard and clicking the mouse, but the computer is not responding and this happens when the computer is taken over – *possessed* – by an appropriately-named computer 'virus'. The operator has lost all influence over the computer which goes its own way making decisions under the control of the 'virus'. I have

just described the dynamic through which the force known to Gnostics as Yaldabaoth and Archons disconnects five-sense mind from expanded awareness to imprison humanity in perceptual servitude.



**Figure 20:** The mind ‘virus’ I have been writing about for decades seeks to isolate five-sense mind (the computer) from the true ‘I’. (Image by Neil Hague).

About a year ago I came across a Native American concept of Wetiko which describes precisely the same phenomenon. Wetiko is the spelling used by the Cree and there are other versions including wintiko and windigo used by other tribal groups. They spell the name with lower case, but I see Wetiko as a proper noun as with Archons and prefer a capital. I first saw an article about Wetiko by writer and researcher Paul Levy which so synced with what I had been writing about the computer/operator disconnection and later the Archons. I then read his book, the fascinating *Dispelling Wetiko, Breaking the Spell of Evil*. The parallels between what I had concluded long before and the Native American concept of Wetiko were so clear and obvious that it was almost funny. For Wetiko see the Gnostic Archons for sure and the Jinn, the Predators, and every other name for a force of evil, inversion and chaos. Wetiko is the Native American name for the force that divides the computer from

the operator (Fig 21). Indigenous author Jack D. Forbes, a founder of the Native American movement in the 1960s, wrote another book about Wetiko entitled *Columbus And Other Cannibals – The Wetiko Disease of Exploitation, Imperialism, and Terrorism* which I also read. Forbes says that Wetiko refers to an evil person or spirit ‘who terrorizes other creatures by means of terrible acts, including cannibalism’. Zulu shaman Credo Mutwa told me that African accounts tell how cannibalism was brought into the world by the Chitauri ‘gods’ – another manifestation of Wetiko. The distinction between ‘evil person or spirit’ relates to Archons/Wetiko possessing a human or acting as pure consciousness. Wetiko is said to be a sickness of the soul or spirit and a state of being that takes but gives nothing back – the Cult and its operatives perfectly described. Black Hawk, a Native American war leader defending their lands from confiscation, said European invaders had ‘poisoned hearts’ – Wetiko hearts – and that this would spread to native societies. Mention of the heart is very significant as we shall shortly see. Forbes writes: ‘Tragically, the history of the world for the past 2,000 years is, in great part, the story of the epidemiology of the wetiko disease.’ Yes, and much longer. Forbes is correct when he says: ‘The wetikos destroyed Egypt and Babylon and Athens and Rome and Tenochtitlan [capital of the Aztec empire] and perhaps now they will destroy the entire earth.’ Evil, he said, is the number one export of a Wetiko culture – see its globalisation with ‘Covid’. Constant war, mass murder, suffering of all kinds, child abuse, Satanism, torture and human sacrifice are all expressions of Wetiko and the Wetiko possessed. The world is Wetiko made manifest, *but it doesn’t have to be*. There is a way out of this even now.



**Figure 21:** The mind 'virus' is known to Native Americans as 'Wetiko'. (Image by Neil Hague).

## **Cult of Wetiko**

Wetiko is the Yaldabaoth frequency distortion that seeks to attach to human consciousness and absorb it into its own. Once this connection is made Wetiko can drive the perceptions of the target which they believe to be coming from their own mind. All the horrors of history and today from mass killers to Satanists, paedophiles like Jeffrey Epstein and other psychopaths, are the embodiment of Wetiko and express its state of being in all its grotesqueness. The Cult is Wetiko incarnate, Yaldabaoth incarnate, and it seeks to facilitate Wetiko assimilation of humanity in totality into its distortion by manipulating the population into low frequency states that match its own. Paul Levy writes: 'Holographically enforced within the psyche of every human being the wetiko virus pervades and underlies the entire field of consciousness, and can therefore potentially manifest through any one of us at any moment if we are not mindful.' The 'Covid' hoax has achieved this with many people, but others have not fallen into Wetiko's frequency lair. Players in the 'Covid' human catastrophe including Gates, Schwab, Tedros, Fauci, Whitty, Vallance, Johnson, Hancock, Ferguson, Drosten, and all the rest, including the psychopath psychologists, are expressions of Wetiko. This is why

they have no compassion or empathy and no emotional consequence for what they do that would make them stop doing it. Observe all the people who support the psychopaths in authority against the Pushbackers despite the damaging impact the psychopaths have on their own lives and their family's lives. You are again looking at Wetiko possession which prevents them seeing through the lies to the obvious scam going on. *Why can't they see it?* Wetiko won't let them see it. The perceptual divide that has now become a chasm is between the Wetikoed and the non-Wetikoed.

Paul Levy describes Wetiko in the same way that I have long described the Archontic force. They are the same distorted consciousness operating across dimensions of reality: '... the subtle body of wetiko is not located in the third dimension of space and time, literally existing in another dimension ... it is able to affect ordinary lives by mysteriously interpenetrating into our three-dimensional world.' Wetiko does this through its incarnate representatives in the Cult and by weaving itself into The Field which on our level of reality is the electromagnetic information field of the simulation or Matrix. More than that, the simulation *is* Wetiko / Yaldabaoth. Caleb Scharf, Director of Astrobiology at Columbia University, has speculated that 'alien life' could be so advanced that it has transcribed itself into the quantum realm to become what we call physics. He said intelligence indistinguishable from the fabric of the Universe would solve many of its greatest mysteries:

Perhaps hyper-advanced life isn't just external. Perhaps it's already all around. It is embedded in what we perceive to be physics itself, from the root behaviour of particles and fields to the phenomena of complexity and emergence ... In other words, life might not just be in the equations. It might BE the equations [My emphasis].

Scharf said it is possible that 'we don't recognise advanced life because it forms an integral and unsuspecting part of what we've considered to be the natural world'. I agree. Wetiko/Yaldabaoth *is* the simulation. We are literally in the body of the beast. But that doesn't mean it has to control us. We all have the power to overcome Wetiko

influence and the Cult knows that. I doubt it sleeps too well because it knows that.

## **Which Field?**

This, I suggest, is how it all works. There are two Fields. One is the fierce electromagnetic light of the Matrix within the speed of light; the other is the 'watery light' of The Field beyond the walls of the Matrix that connects with the Great Infinity. Five-sense mind and the decoding systems of the body attach us to the Field of Matrix light. They have to or we could not experience this reality. Five-sense mind sees only the Matrix Field of information while our expanded consciousness is part of the Infinity Field. When we open our minds, and most importantly our hearts, to the Infinity Field we have a mission control which gives us an expanded perspective, a road map, to understand the nature of the five-sense world. If we are isolated only in five-sense mind there is no mission control. We're on our own trying to understand a world that's constantly feeding us information to ensure we do not understand. People in this state can feel 'lost' and bewildered with no direction or radar. You can see ever more clearly those who are influenced by the Fields of Big Infinity or little five-sense mind simply by their views and behaviour with regard to the 'Covid' hoax. We have had this division throughout known human history with the mass of the people on one side and individuals who could see and intuit beyond the walls of the simulation – Plato's prisoner who broke out of the cave and saw reality for what it is. Such people have always been targeted by Wetiko/Archon-possessed authority, burned at the stake or demonised as mad, bad and dangerous. The Cult today and its global network of 'anti-hate', 'anti-fascist' Woke groups are all expressions of Wetiko attacking those exposing the conspiracy, 'Covid' lies and the 'vaccine' agenda.

Woke as a whole is Wetiko which explains its black and white mentality and how at one it is with the Wetiko-possessed Cult. Paul Levy said: 'To be in this paradigm is to still be under the thrall of a two-valued logic – where things are either true or false – of a

wetikoized mind.’ Wetiko consciousness is in a permanent rage, therefore so is Woke, and then there is Woke inversion and contradiction. ‘Anti-fascists’ act like fascists because fascists *and* ‘anti-fascists’ are both Wetiko at work. Political parties act the same while claiming to be different for the same reason. Secret society and satanic rituals are attaching initiates to Wetiko and the cold, ruthless, psychopathic mentality that secures the positions of power all over the world is Wetiko. Reframing ‘training programmes’ have the same cumulative effect of attaching Wetiko and we have their graduates described as automatons and robots with a cold, psychopathic, uncaring demeanour. They are all traits of Wetiko possession and look how many times they have been described in this book and elsewhere with regard to personnel behind ‘Covid’ including the police and medical profession. Climbing the greasy pole in any profession in a Wetiko society requires traits of Wetiko to get there and that is particularly true of politics which is not about fair competition and pre-eminence of ideas. It is founded on how many backs you can stab and arses you can lick. This culminated in the global ‘Covid’ coordination between the Wetiko possessed who pulled it off in all the different countries without a trace of empathy and compassion for their impact on humans. Our sight sense can see only holographic form and not the Field which connects holographic form. Therefore we perceive ‘physical’ objects with ‘space’ in between. In fact that ‘space’ is energy/consciousness operating on multiple frequencies. One of them is Wetiko and that connects the Cult psychopaths, those who submit to the psychopaths, and those who serve the psychopaths in the media operations of the world. Wetiko is Gates. Wetiko is the mask-wearing submissive. Wetiko is the fake journalist and ‘fact-checker’. The Wetiko Field is coordinating the whole thing. Psychopaths, gofers, media operatives, ‘anti-hate’ hate groups, ‘fact-checkers’ and submissive people work as one unit *even without human coordination* because they are attached to the *same* Field which is organising it all (Fig 22). Paul Levy is here describing how Wetiko-possessed people are drawn together and refuse to let any information breach their rigid

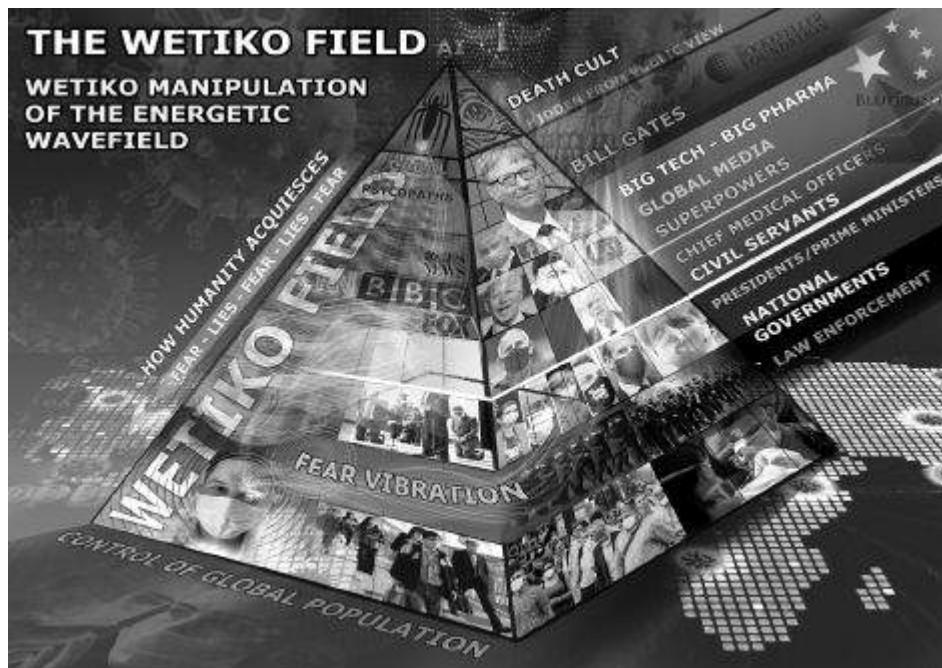


perceptions. He was writing long before 'Covid', but I think you will recognise followers of the 'Covid' religion *oh just a little bit*:

People who are channelling the vibratory frequency of wetiko align with each other through psychic resonance to reinforce their unspoken shared agreement so as to uphold their deranged view of reality. Once an unconscious content takes possession of certain individuals, it irresistibly draws them together by mutual attraction and knits them into groups tied together by their shared madness that can easily swell into an avalanche of insanity.

A psychic epidemic is a closed system, which is to say that it is insular and not open to any new information or informing influences from the outside world which contradict its fixed, limited, and limiting perspective.

There we have the Woke mind and the 'Covid' mind. Compatible resonance draws the awakening together, too, which is clearly happening today.



**Figure 22:** The Wetiko Field from which the Cult pyramid and its personnel are made manifest. (Image by Neil Hague).

## **Spiritual servitude**

Wetiko doesn't care about humans. It's not human; it just possesses humans for its own ends and the effect (depending on the scale of

possession) can be anything from extreme psychopathy to unquestioning obedience. Wetiko's worst nightmare is for human consciousness to expand beyond the simulation. Everything is focussed on stopping that happening through control of information, thus perception, thus frequency. The 'education system', media, science, medicine, academia, are all geared to maintaining humanity in five-sense servitude as is the constant stimulation of low-vibrational mental and emotional states (see 'Covid'). Wetiko seeks to dominate those subconscious spaces between five-sense perception and expanded consciousness where the computer meets the operator. From these subconscious hiding places Wetiko speaks to us to trigger urges and desires that we take to be our own and manipulate us into anything from low-vibrational to psychopathic states. Remember how Islam describes the Jinn as invisible tricksters that 'whisper' and confuse. Wetiko is the origin of the 'trickster god' theme that you find in cultures all over the world. Jinn, like the Archons, are Wetiko which is terrified of humans awakening and reconnecting with our true self for then its energy source has gone. With that the feedback loop breaks between Wetiko and human perception that provides the energetic momentum on which its very existence depends as a force of evil. Humans are both its target and its source of survival, but only if we are operating in low-vibrational states of fear, hate, depression and the background anxiety that most people suffer. We are Wetiko's target because we are its key to survival. It needs us, not the other way round. Paul Levy writes:

A vampire has no intrinsic, independent, substantial existence in its own right; it only exists in relation to us. The pathogenic, vampiric mind-parasite called wetiko is nothing in itself – not being able to exist from its own side – yet it has a 'virtual reality' such that it can potentially destroy our species ...

...The fact that a vampire is not reflected by a mirror can also mean that what we need to see is that there's nothing, no-thing to see, other than ourselves. The fact that wetiko is the expression of something inside of us means that the cure for wetiko is with us as well. The critical issue is finding this cure within us and then putting it into effect.

Evil begets evil because if evil does not constantly expand and find new sources of energetic sustenance its evil, its *distortion*, dies with the assimilation into balance and harmony. Love is the garlic to Wetiko's vampire. Evil, the absence of love, cannot exist in the presence of love. I think I see a way out of here. I have emphasised so many times over the decades that the Archons/Wetiko and their Cult are not all powerful. *They are not*. I don't care how it looks even now *they are not*. I have not called them little boys in short trousers for effect. I have said it because it is true. Wetiko's insatiable desire for power over others is not a sign of its omnipotence, but its insecurity. Paul Levy writes: 'Due to the primal fear which ultimately drives it and which it is driven to cultivate, wetiko's body politic has an intrinsic and insistent need for centralising power and control so as to create imagined safety for itself.' *Yeaaaaees!* Exactly! Why does Wetiko want humans in an ongoing state of fear? Wetiko itself *is* fear and it is petrified of love. As evil is an absence of love, so love is an absence of fear. Love conquers all and *especially* Wetiko which *is* fear. Wetiko brought fear into the world when it wasn't here before. *Fear* was the 'fall', the fall into low-frequency ignorance and illusion – fear is **False Emotion Appearing Real**. The simulation is driven and energised by fear because Wetiko/Yaldabaoth (fear) *are* the simulation. Fear is the absence of love and Wetiko is the absence of love.

## **Wetiko today**

We can now view current events from this level of perspective. The 'Covid' hoax has generated momentous amounts of ongoing fear, anxiety, depression and despair which have empowered Wetiko. No wonder people like Gates have been the instigators when they are Wetiko incarnate and exhibit every trait of Wetiko in the extreme. See how cold and unemotional these people are like Gates and his cronies, how dead of eye they are. That's Wetiko. Sabbatians are Wetiko and everything they control including the World Health Organization, Big Pharma and the 'vaccine' makers, national 'health'

hierarchies, corporate media, Silicon Valley, the banking system, and the United Nations with its planned transformation into world government. All are controlled and possessed by the Wetiko distortion into distorting human society in its image. We are with this knowledge at the gateway to understanding the world. Divisions of race, culture, creed and sexuality are diversions to hide the real division between those possessed and influenced by Wetiko and those that are not. The 'Covid' hoax has brought both clearly into view. Human behaviour is not about race. Tyrants and dictatorships come in all colours and creeds. What unites the US president bombing the innocent and an African tribe committing genocide against another as in Rwanda? What unites them? *Wetiko*. All wars are Wetiko, all genocide is Wetiko, all hunger over centuries in a world of plenty is Wetiko. Children going to bed hungry, including in the West, is Wetiko. Cult-generated Woke racial divisions that focus on the body are designed to obscure the reality that divisions in behaviour are manifestations of mind, not body. Obsession with body identity and group judgement is a means to divert attention from the real source of behaviour – mind and perception. Conflict sown by the Woke both within themselves and with their target groups are Wetiko providing lunch for itself through still more agents of the division, chaos, and fear on which it feeds. The Cult is seeking to assimilate the entirety of humanity and all children and young people into the Wetiko frequency by manipulating them into states of fear and despair. Witness all the suicide and psychological unravelling since the spring of 2020. Wetiko psychopaths want to impose a state of unquestioning obedience to authority which is no more than a conduit for Wetiko to enforce its will and assimilate humanity into itself. It needs us to believe that resistance is futile when it fears resistance and even more so the game-changing non-cooperation with its impositions. It can use violent resistance for its benefit. Violent impositions and violent resistance are *both* Wetiko. The Power of Love with its Power of No will sweep Wetiko from our world. Wetiko and its Cult know that. They just don't want us to know.

## **AI Wetiko**

This brings me to AI or artificial intelligence and something else Wetikos don't want us to know. What is AI *really*? I know about computer code algorithms and AI that learns from data input. These, however, are more diversions, the expeditionary force, for the real AI that they want to connect to the human brain as promoted by Silicon Valley Wetikos like Kurzweil. What is this AI? It is the frequency of *Wetiko*, the frequency of the Archons. The connection of AI to the human brain is the connection of the Wetiko frequency to create a Wetiko hive mind and complete the job of assimilation. The hive mind is planned to be controlled from Israel and China which are both 100 percent owned by Wetiko Sabbatians. The assimilation process has been going on minute by minute in the 'smart' era which fused with the 'Covid' era. We are told that social media is scrambling the minds of the young and changing their personality. This is true, but what is social media? Look more deeply at how it works, how it creates divisions and conflict, the hostility and cruelty, the targeting of people until they are destroyed. That's Wetiko. Social media is manipulated to tune people to the Wetiko frequency with all the emotional exploitation tricks employed by platforms like Facebook and its Wetiko front man, Zuckerberg. Facebook's Instagram announced a new platform for children to overcome a legal bar on them using the main site. This is more Wetiko exploitation and manipulation of kids. Amnesty International likened the plan to foxes offering to guard the henhouse and said it was incompatible with human rights. Since when did Wetiko or Zuckerberg (I repeat myself) care about that? Would Brin and Page at Google, Wojcicki at YouTube, Bezos at Amazon and whoever the hell runs Twitter act as they do if they were not channelling Wetiko? Would those who are developing technologies for no other reason than human control? How about those designing and selling technologies to kill people and Big Pharma drug and 'vaccine' producers who know they will end or devastate lives? Quite a thought for these people to consider is that if you are Wetiko in a human life you are Wetiko on the 'other side' unless your frequency

changes and that can only change by a change of perception which becomes a change of behaviour. Where Gates is going does not bear thinking about although perhaps that's exactly where he wants to go. Either way, that's where he's going. His frequency will make it so.

## **The frequency lair**

I have been saying for a long time that a big part of the addiction to smartphones and devices is that a frequency is coming off them that entraps the mind. People spend ages on their phones and sometimes even a minute or so after they put them down they pick them up again and it all repeats. 'Covid' lockdowns will have increased this addiction a million times for obvious reasons. Addictions to alcohol overindulgence and drugs are another way that Wetiko entraps consciousness to attach to its own. Both are symptoms of low-vibrational psychological distress which alcoholism and drug addiction further compound. Do we think it's really a coincidence that access to them is made so easy while potions that can take people into realms beyond the simulation are banned and illegal? I have explored smartphone addiction in other books, the scale is mind-blowing, and that level of addiction does not come without help. Tech companies that make these phones are Wetiko and they will have no qualms about destroying the minds of children. We are seeing again with these companies the Wetiko perceptual combination of psychopathic enforcers and weak and meek unquestioning compliance by the rank and file.

The global Smart Grid is the Wetiko Grid and it is crucial to complete the Cult endgame. The simulation is radiation and we are being deluged with technological radiation on a devastating scale. Wetiko frauds like Elon Musk serve Cult interests while occasionally criticising them to maintain his street-cred. 5G and other forms of Wi-Fi are being directed at the earth from space on a volume and scale that goes on increasing by the day. Elon Musk's (officially) SpaceX Starlink project is in the process of putting tens of thousands of satellites in low orbit to cover every inch of the planet with 5G and other Wi-Fi to create Kurzweil's global 'cloud' to which the

human mind is planned to be attached very soon. SpaceX has approval to operate 12,000 satellites with more than 1,300 launched at the time of writing and applications filed for 30,000 more. Other operators in the Wi-Fi, 5G, low-orbit satellite market include OneWeb (UK), Telesat (Canada), and AST & Science (US). Musk tells us that AI could be the end of humanity and then launches a company called Neuralink to connect the human brain to computers. Musk's (in theory) Tesla company is building electric cars and the driverless vehicles of the smart control grid. As frauds and bullshitters go Elon Musk in my opinion is Major League.

5G and technological radiation in general are destructive to human health, genetics and psychology and increasing the strength of artificial radiation underpins the five-sense perceptual bubbles which are themselves expressions of radiation or electromagnetism. Freedom activist John Whitehead was so right with his 'databit by databit, we are building our own electronic concentration camps'. The Smart Grid and 5G is a means to control the human mind and infuse perceptual information into The Field to influence anyone in sync with its frequency. You can change perception and behaviour en masse if you can manipulate the population into those levels of frequency and this is happening all around us today. The arrogance of Musk and his fellow Cult operatives knows no bounds in the way that we see with Gates. Musk's satellites are so many in number already they are changing the night sky when viewed from Earth. The astronomy community has complained about this and they have seen nothing yet. Some consequences of Musk's Wetiko hubris include: Radiation; visible pollution of the night sky; interference with astronomy and meteorology; ground and water pollution from intensive use of increasingly many spaceports; accumulating space debris; continual deorbiting and burning up of aging satellites, polluting the atmosphere with toxic dust and smoke; and ever-increasing likelihood of collisions. A collective public open letter of complaint to Musk said:

We are writing to you ... because SpaceX is in process of surrounding the Earth with a network of thousands of satellites whose very purpose is to irradiate every square inch of the

Earth. SpaceX, like everyone else, is treating the radiation as if it were not there. As if the mitochondria in our cells do not depend on electrons moving undisturbed from the food we digest to the oxygen we breathe.

As if our nervous systems and our hearts are not subject to radio frequency interference like any piece of electronic equipment. As if the cancer, diabetes, and heart disease that now afflict a majority of the Earth's population are not metabolic diseases that result from interference with our cellular machinery. As if insects everywhere, and the birds and animals that eat them, are not starving to death as a result.

People like Musk and Gates believe in their limitless Wetiko arrogance that they can do whatever they like to the world because they own it. Consequences for humanity are irrelevant. It's absolutely time that we stopped taking this shit from these self-styled masters of the Earth when you consider where this is going.

## **Why is the Cult so anti-human?**

I hear this question often: Why would they do this when it will affect them, too? Ah, but will it? Who is this *them*? Forget their bodies. They are just vehicles for Wetiko consciousness. When you break it all down to the foundations we are looking at a state of severely distorted consciousness targeting another state of consciousness for assimilation. The rest is detail. The simulation is the fly-trap in which unique sensations of the five senses create a cycle of addiction called reincarnation. Renegade Minds see that everything which happens in our reality is a smaller version of the whole picture in line with the holographic principle. Addiction to the radiation of smart technology is a smaller version of addiction to the whole simulation. Connecting the body/brain to AI is taking that addiction on a giant step further to total ongoing control by assimilating human incarnate consciousness into Wetiko. I have watched during the 'Covid' hoax how many are becoming ever more profoundly attached to Wetiko's perceptual calling cards of aggressive response to any other point of view ('There is no other god but me'), psychopathic lack of compassion and empathy, and servile submission to the narrative and will of authority. Wetiko is the psychopaths *and* subservience to psychopaths. The Cult of Wetiko is



so anti-human because it is *not* human. It embarked on a mission to destroy human by targeting everything that it means to be human and to survive as human. 'Covid' is not the end, just a means to an end. The Cult with its Wetiko consciousness is seeking to change Earth systems, including the atmosphere, to suit them, not humans. The gathering bombardment of 5G alone from ground and space is dramatically changing The Field with which the five senses interact. There is so much more to come if we sit on our hands and hope it will all go away. It is not meant to go away. It is meant to get ever more extreme and we need to face that while we still can – just.

Carbon dioxide is the gas of life. Without that human is over. Kaput, gone, history. No natural world, no human. The Cult has created a cock and bull story about carbon dioxide and climate change to justify its reduction to the point where Gates and the ignoramus Biden 'climate chief' John Kerry want to suck it out of the atmosphere. Kerry wants to do this because his master Gates does. Wetikos have made the gas of life a demon with the usual support from the Wokers of Extinction Rebellion and similar organisations and the bewildered puppet-child that is Greta Thunberg who was put on the world stage by Klaus Schwab and the World Economic Forum. The name Extinction Rebellion is both ironic and as always Wetiko inversion. The gas that we need to survive must be reduced to save us from extinction. The most basic need of human is oxygen and we now have billions walking around in face nappies depriving body and brain of this essential requirement of human existence. More than that 5G at 60 gigahertz interacts with the oxygen molecule to reduce the amount of oxygen the body can absorb into the bloodstream. The obvious knock-on consequences of that for respiratory and cognitive problems and life itself need no further explanation. Psychopaths like Musk are assembling a global system of satellites to deluge the human atmosphere with this insanity. The man should be in jail. Here we have two most basic of human needs, oxygen and carbon dioxide, being dismantled.

Two others, water and food, are getting similar treatment with the United Nations Agendas 21 and 2030 – the Great Reset – planning to

centrally control all water and food supplies. People will not even own rain water that falls on their land. Food is affected at the most basic level by reducing carbon dioxide. We have genetic modification or GMO infiltrating the food chain on a mass scale, pesticides and herbicides polluting the air and destroying the soil. Freshwater fish that provide livelihoods for 60 million people and feed hundreds of millions worldwide are being 'pushed to the brink' according the conservationists while climate change is the only focus. Now we have Gates and Schwab wanting to dispense with current food sources all together and replace them with a synthetic version which the Wetiko Cult would control in terms of production and who eats and who doesn't. We have been on the Totalitarian Tiptoe to this for more than 60 years as food has become ever more processed and full of chemical shite to the point today when it's not natural food at all. As Dr Tom Cowan says: 'If it has a label don't eat it.' Bill Gates is now the biggest owner of farmland in the United States and he does nothing without an ulterior motive involving the Cult. Klaus Schwab wrote: 'To feed the world in the next 50 years we will need to produce as much food as was produced in the last 10,000 years ... food security will only be achieved, however, if regulations on genetically modified foods are adapted to reflect the reality that gene editing offers a precise, efficient and safe method of improving crops.' Liar. People and the world are being targeted with aluminium through vaccines, chemtrails, food, drink cans, and endless other sources when aluminium has been linked to many health issues including dementia which is increasing year after year. Insects, bees and wildlife essential to the food chain are being deleted by pesticides, herbicides and radiation which 5G is dramatically increasing with 6G and 7G to come. The pollinating bee population is being devastated while wildlife including birds, dolphins and whales are having their natural radar blocked by the effects of ever-increasing radiation. In the summer windscreens used to be splattered with insects so numerous were they. It doesn't happen now. Where have they gone?

## **Synthetic everything**

The Cult is introducing genetically-modified versions of trees, plants and insects including a Gates-funded project to unleash hundreds of millions of genetically-modified, lab-altered and patented male mosquitoes to mate with wild mosquitoes and induce genetic flaws that cause them to die out. Clinically-insane Gates-funded Japanese researchers have developed mosquitos that spread vaccine and are dubbed 'flying vaccinators'. Gates is funding the modification of weather patterns in part to sell the myth that this is caused by carbon dioxide and he's funding geoengineering of the skies to change the atmosphere. Some of this came to light with the Gates-backed plan to release tonnes of chalk into the atmosphere to 'deflect the Sun and cool the planet'. Funny how they do this while the heating effect of the Sun is not factored into climate projections focussed on carbon dioxide. The reason is that they want to reduce carbon dioxide (so don't mention the Sun), but at the same time they do want to reduce the impact of the Sun which is so essential to human life and health. I have mentioned the sun-cholesterol-vitamin D connection as they demonise the Sun with warnings about skin cancer (caused by the chemicals in sun cream they tell you to splash on). They come from the other end of the process with statin drugs to reduce cholesterol that turns sunlight into vitamin D. A lack of vitamin D leads to a long list of health effects and how vitamin D levels must have fallen with people confined to their homes over 'Covid'. Gates is funding other forms of geoengineering and most importantly chemtrails which are dropping heavy metals, aluminium and self-replicating nanotechnology onto the Earth which is killing the natural world. See *Everything You Need To Know, But Have Never Been Told* for the detailed background to this.

Every human system is being targeted for deletion by a force that's not human. The Wetiko Cult has embarked on the process of transforming the human body from biological to synthetic biological as I have explained. Biological is being replaced by the artificial and synthetic – Archontic 'countermimicry' – right across human society. The plan eventually is to dispense with the human body altogether

and absorb human consciousness – which it wouldn't really be by then – into cyberspace (the simulation which is Wetiko/Yaldabaoth). Preparations for that are already happening if people would care to look. The alternative media rightly warns about globalism and 'the globalists', but this is far bigger than that and represents the end of the human race as we know it. The 'bad copy' of prime reality that Gnostics describe was a bad copy of harmony, wonder and beauty to start with before Wetiko/Yaldabaoth set out to change the simulated 'copy' into something very different. The process was slow to start with. Entrapped humans in the simulation timeline were not technologically aware and they had to be brought up to intellectual speed while being suppressed spiritually to the point where they could build their own prison while having no idea they were doing so. We have now reached that stage where technological intellect has the potential to destroy us and that's why events are moving so fast. Central American shaman Don Juan Matus said:

Think for a moment, and tell me how you would explain the contradictions between the intelligence of man the engineer and the stupidity of his systems of belief, or the stupidity of his contradictory behaviour. Sorcerers believe that the predators have given us our systems of beliefs, our ideas of good and evil; our social mores. They are the ones who set up our dreams of success or failure. They have given us covetousness, greed, and cowardice. It is the predator who makes us complacent, routinary, and egomaniacal.

In order to keep us obedient and meek and weak, the predators engaged themselves in a stupendous manoeuvre – stupendous, of course, from the point of view of a fighting strategist; a horrendous manoeuvre from the point of those who suffer it. They gave us their mind. The predators' mind is baroque, contradictory, morose, filled with the fear of being discovered any minute now.

For 'predators' see Wetiko, Archons, Yaldabaoth, Jinn, and all the other versions of the same phenomenon in cultures and religions all over the world. The theme is always the same because it's true and it's real. We have reached the point where we have to deal with it. The question is – how?

**Don't fight – walk away**

I thought I'd use a controversial subheading to get things moving in terms of our response to global fascism. What do you mean 'don't fight'? What do you mean 'walk away'? We've got to fight. We can't walk away. Well, it depends what we mean by fight and walk away. If fighting means physical combat we are playing Wetiko's game and falling for its trap. It wants us to get angry, aggressive, and direct hate and hostility at the enemy we think we must fight. Every war, every battle, every conflict, has been fought with Wetiko leading both sides. It's what it does. Wetiko wants a fight, anywhere, any place. Just hit me, son, so I can hit you back. Wetiko hits Wetiko and Wetiko hits Wetiko in return. I am very forthright as you can see in exposing Wetikos of the Cult, but I don't hate them. I refuse to hate them. It's what they want. What you hate you become. What you *fight* you become. Wokers, 'anti-haters' and 'anti-fascists' prove this every time they reach for their keyboards or don their balaclavas. By walk away I mean to disengage from Wetiko which includes ceasing to cooperate with its tyranny. Paul Levy says of Wetiko:

The way to 'defeat' evil is not to try to destroy it (for then, in playing evil's game, we have already lost), but rather, to find the invulnerable place within ourselves where evil is unable to vanquish us – this is to truly 'win' our battle with evil.

Wetiko is everywhere in human society and it's been on steroids since the 'Covid' hoax. Every shouting match over wearing masks has Wetiko wearing a mask and Wetiko not wearing one. It's an electrical circuit of push and resist, push and resist, with Wetiko pushing *and* resisting. Each polarity is Wetiko empowering itself. Dictionary definitions of 'resist' include 'opposing, refusing to accept or comply with' and the word to focus on is 'opposing'. What form does this take – setting police cars alight or 'refusing to accept or comply with'? The former is Wetiko opposing Wetiko while the other points the way forward. This is the difference between those aggressively demanding that government fascism must be obeyed who stand in stark contrast to the great majority of Pushbackers. We saw this clearly with a march by thousands of Pushbackers against lockdown in London followed days later by a Woker-hijacked

protest in Bristol in which police cars were set on fire. Masks were virtually absent in London and widespread in Bristol. Wetiko wants lockdown on every level of society and infuses its aggression to police it through its unknowing stooges. Lockdown protesters are the ones with the smiling faces and the hugs, The two blatantly obvious states of being – getting more obvious by the day – are the result of Wokers and their like becoming ever more influenced by the simulation Field of Wetiko and Pushbackers ever more influenced by The Field of a far higher vibration beyond the simulation. Wetiko can't invade the heart which is where most lockdown opponents are coming from. It's the heart that allows them to see through the lies to the truth in ways I will be highlighting.

Renegade Minds know that calmness is the place from which wisdom comes. You won't find wisdom in a hissing fit and wisdom is what we need in abundance right now. Calmness is not weakness – you don't have to scream at the top of your voice to be strong. Calmness is indeed a sign of strength. 'No' means I'm not doing it. NOOOO!!! doesn't mean you're not doing it even more. Volume does not advance 'No – I'm not doing it'. You are just not doing it. Wetiko possessed and influenced don't know how to deal with that. Wetiko wants a fight and we should not give it one. What it needs more than anything is our *cooperation* and we should not give that either. Mass rallies and marches are great in that they are a visual representation of feeling, but if it ends there they are irrelevant. You demand that Wetikos act differently? Well, they're not going to are they? They are Wetikos. We don't need to waste our time demanding that something doesn't happen when that will make no difference. We need to delete the means that *allows* it to happen. This, invariably, is our cooperation. You can demand a child stop firing a peashooter at the dog or you can refuse to buy the peashooter. If you provide the means you are cooperating with the dog being smacked on the nose with a pea. How can the authorities enforce mask-wearing if millions in a country refuse? What if the 74 million Pushbackers that voted for Trump in 2020 refused to wear masks, close their businesses or stay in their homes. It would be unenforceable. The

few control the many through the compliance of the many and that's always been the dynamic be it 'Covid' regulations or the Roman Empire. I know people can find it intimidating to say no to authority or stand out in a crowd for being the only one with a face on display; but it has to be done or it's over. I hope I've made clear in this book that where this is going will be far more intimidating than standing up now and saying 'No' – I will not cooperate with my own enslavement and that of my children. There might be consequences for some initially, although not so if enough do the same. The question that must be addressed is what is going to happen if we don't? It is time to be strong and unyieldingly so. No means no. Not here and there, but *everywhere* and *always*. I have refused to wear a mask and obey all the other nonsense. I will not comply with tyranny. I repeat: Fascism is not imposed by fascists – there are never enough of them. Fascism is imposed by the population acquiescing to fascism. *I will not do it*. I will die first, or my body will. Living meekly under fascism is a form of death anyway, the death of the spirit that Martin Luther King described.

## **Making things happen**

We must not despair. This is not over till it's over and it's far from that. The 'fat lady' must refuse to sing. The longer the 'Covid' hoax has dragged on and impacted on more lives we have seen an awakening of phenomenal numbers of people worldwide to the realisation that what they have believed all their lives is not how the world really is. Research published by the system-serving University of Bristol and King's College London in February, 2021, concluded: 'One in every 11 people in Britain say they trust David Icke's take on the coronavirus pandemic.' It will be more by now and we have gathering numbers to build on. We must urgently progress from seeing the scam to ceasing to cooperate with it. Prominent German lawyer Reiner Fuellmich, also licenced to practice law in America, is doing a magnificent job taking the legal route to bring the psychopaths to justice through a second Nuremberg tribunal for crimes against humanity. Fuellmich has an impressive record of

beating the elite in court and he formed the German Corona Investigative Committee to pursue civil charges against the main perpetrators with a view to triggering criminal charges. Most importantly he has grasped the foundation of the hoax – the PCR test not testing for the ‘virus’ – and Christian Drosten is therefore on his charge sheet along with Gates frontman Tedros at the World Health Organization. Major players must not be allowed to inflict their horrors on the human race without being brought to book. A life sentence must follow for Bill Gates and the rest of them. A group of researchers has also indicted the government of Norway for crimes against humanity with copies sent to the police and the International Criminal Court. The lawsuit cites participation in an internationally-planned false pandemic and violation of international law and human rights, the European Commission’s definition of human rights by coercive rules, Nuremberg and Hague rules on fundamental human rights, and the Norwegian constitution. We must take the initiative from hereon and not just complain, protest and react.

There are practical ways to support vital mass non-cooperation. Organising in numbers is one. Lockdown marches in London in the spring in 2021 were mass non-cooperation that the authorities could not stop. There were too many people. Hundreds of thousands walked the London streets in the centre of the road for mile after mile while the Face-Nappies could only look on. They were determined, but calm, and just *did it* with no histrionics and lots of smiles. The police were impotent. Others are organising group shopping without masks for mutual support and imagine if that was happening all over. Policing it would be impossible. If the store refuses to serve people in these circumstances they would be faced with a long line of trolleys full of goods standing on their own and everything would have to be returned to the shelves. How would they cope with that if it kept happening? I am talking here about moving on from complaining to being pro-active; from watching things happen to making things happen. I include in this our relationship with the police. The behaviour of many Face-Nappies



has been disgraceful and anyone who thinks they would never find concentration camp guards in the 'enlightened' modern era have had that myth busted big-time. The period and setting may change – Wetikos never do. I watched film footage from a London march in which a police thug viciously kicked a protestor on the floor who had done nothing. His fellow Face-Nappies stood in a ring protecting him. What he did was a criminal assault and with a crowd far outnumbering the police this can no longer be allowed to happen unchallenged. I get it when people chant 'shame on you' in these circumstances, but that is no longer enough. They *have* no shame those who do this. Crowds needs to start making a citizen's arrest of the police who commit criminal offences and brutally attack innocent people and defenceless women. A citizen's arrest can be made under section 24A of the UK Police and Criminal Evidence (PACE) Act of 1984 and you will find something similar in other countries. I prefer to call it a Common Law arrest rather than citizen's for reasons I will come to shortly. Anyone can arrest a person committing an indictable offence or if they have reasonable grounds to suspect they are committing an indictable offence. On both counts the attack by the police thug would have fallen into this category. A citizen's arrest can be made to stop someone:

- Causing physical injury to himself or any other person
- Suffering physical injury
- Causing loss of or damage to property
- Making off before a constable can assume responsibility for him

A citizen's arrest may also be made to prevent a breach of the peace under Common Law and if they believe a breach of the peace will happen or anything related to harm likely to be done or already done in their presence. This is the way to go I think – the Common Law version. If police know that the crowd and members of the public will no longer be standing and watching while they commit

their thuggery and crimes they will think twice about acting like Brownshirts and Blackshirts.

## **Common Law – common sense**

Mention of Common Law is very important. Most people think the law is the law as in one law. This is not the case. There are two bodies of law, Common Law and Statute Law, and they are not the same. Common Law is founded on the simple premise of do no harm. It does not recognise victimless crimes in which no harm is done while Statute Law does. There is a Statute Law against almost everything. So what is Statute Law? Amazingly it's the law of the *sea* that was brought ashore by the Cult to override the law of the land which is Common Law. They had no right to do this and as always they did it anyway. They had to. They could not impose their will on the people through Common Law which only applies to do no harm. How could you stitch up the fine detail of people's lives with that? Instead they took the law of the sea, or Admiralty Law, and applied it to the population. Statute Law refers to all the laws spewing out of governments and their agencies including all the fascist laws and regulations relating to 'Covid'. The key point to make is that Statute Law is *contract law*. It only applies between *contracting* corporations. Most police officers don't even know this. They have to be kept in the dark, too. Long ago when merchants and their sailing ships began to trade with different countries a contractual law was developed called Admiralty Law and other names. Again it only applied to *contracts* agreed between *corporate* entities. If there is no agreed contract the law of the sea had no jurisdiction *and that still applies to its new alias of Statute Law*. The problem for the Cult when the law of the sea was brought ashore was an obvious one. People were not corporations and neither were government entities. To overcome the latter they made governments and all associated organisations corporations. All the institutions are *private corporations* and I mean governments and their agencies, local councils, police, courts, military, US states, the whole lot. Go to the

Dun and Bradstreet corporate listings website for confirmation that they are all corporations. You are arrested by a private corporation called the police by someone who is really a private security guard and they take you to court which is another private corporation. Neither have jurisdiction over you unless you consent and *contract* with them. This is why you hear the mantra about law enforcement policing by *consent* of the people. In truth the people 'consent' only in theory through monumental trickery.

Okay, the Cult overcame the corporate law problem by making governments and institutions corporate entities; but what about people? They are not corporations are they? Ah ... well in a sense, and *only* a sense, they are. Not people exactly – the illusion of people. The Cult creates a corporation in the name of everyone at the time that their birth certificate is issued. Note birth/ *berth* certificate and when you go to court under the law of the sea on land you stand in a *dock*. These are throwbacks to the origin. My Common Law name is David Vaughan Icke. The name of the corporation created by the government when I was born is called Mr David Vaughan Icke usually written in capitals as MR DAVID VAUGHAN ICKE. That is not me, the living, breathing man. It is a fictitious corporate entity. The trick is to make you think that David Vaughan Icke and MR DAVID VAUGHAN ICKE are the same thing. *They are not*. When police charge you and take you to court they are prosecuting the corporate entity and not the living, breathing, man or woman. They have to trick you into identifying as the corporate entity and contracting with them. Otherwise they have no jurisdiction. They do this through a language known as legalese. Lawful and legal are not the same either. Lawful relates to Common Law and legal relates to Statute Law. Legalese is the language of Statue Law which uses terms that mean one thing to the public and another in legalese. Notice that when a police officer tells someone why they are being charged he or she will say at the end: 'Do you understand?' To the public that means 'Do you comprehend?' In legalese it means 'Do you stand under me?' Do you stand under my authority? If you say

yes to the question you are unknowingly agreeing to give them jurisdiction over you in a contract between two corporate entities.

This is a confidence trick in every way. Contracts have to be agreed between informed parties and if you don't know that David Vaughan Icke is agreeing to be the corporation MR DAVID VAUGHAN ICKE you cannot knowingly agree to contract. They are deceiving you and another way they do this is to ask for proof of identity. You usually show them a driving licence or other document on which your corporate name is written. In doing so you are accepting that you are that corporate entity when you are not. Referring to yourself as a 'person' or 'citizen' is also identifying with your corporate fiction which is why I made the Common Law point about the citizen's arrest. If you are approached by a police officer you identify yourself immediately as a living, breathing, man or woman and say 'I do not consent, I do not contract with you and I do not understand' or stand under their authority. I have a Common Law birth certificate as a living man and these are available at no charge from [commonlawcourt.com](http://commonlawcourt.com). Businesses registered under the Statute Law system means that its laws apply. There are, however, ways to run a business under Common Law. Remember all 'Covid' laws and regulations are Statute Law – the law of *contracts* and you do not have to contract. This doesn't mean that you can kill someone and get away with it. Common Law says do no harm and that applies to physical harm, financial harm etc. Police are employees of private corporations and there needs to be a new system of non-corporate Common Law constables operating outside the Statute Law system. If you go to [davidicke.com](http://davidicke.com) and put Common Law into the search engine you will find videos that explain Common Law in much greater detail. It is definitely a road we should walk.

### **With all my heart**

I have heard people say that we are in a spiritual war. I don't like the term 'war' with its Wetiko dynamic, but I know what they mean. Sweep aside all the bodily forms and we are in a situation in which two states of consciousness are seeking very different realities.

Wetiko wants upheaval, chaos, fear, suffering, conflict and control. The other wants love, peace, harmony, fairness and freedom. That's where we are. We should not fall for the idea that Wetiko is all-powerful and there's nothing we can do. Wetiko is not all-powerful. It's a joke, pathetic. It doesn't have to be, but it has made that choice for now. A handful of times over the years when I have felt the presence of its frequency I have allowed it to attach briefly so I could consciously observe its nature. The experience is not pleasant, the energy is heavy and dark, but the ease with which you can kick it back out the door shows that its real power is in persuading us that it has power. It's all a con. Wetiko is a con. It's a trickster and not a power that can control us if we unleash our own. The con is founded on manipulating humanity to give its power to Wetiko which recycles it back to present the illusion that it has power when its power is *ours* that we gave away. This happens on an energetic level and plays out in the world of the seen as humanity giving its power to Wetiko authority which uses that power to control the population when the power is only the power the population has handed over. How could it be any other way for billions to be controlled by a relative few? I have had experiences with people possessed by Wetiko and again you can kick its arse if you do it with an open heart. Oh yes – the *heart* which can transform the world of perceived 'matter'.

We are receiver-transmitters and processors of information, but what information and where from? Information is processed into perception in three main areas – the brain, the heart and the belly. These relate to thinking, knowing, and emotion. Wetiko wants us to be head and belly people which means we think within the confines of the Matrix simulation and low-vibrational emotional reaction scrambles balance and perception. A few minutes on social media and you see how emotion is the dominant force. Woke is all emotion and is therefore thought-free and fact-free. Our heart is something different. It *knows* while the head *thinks* and has to try to work it out because it doesn't know. The human energy field has seven prime vortexes which connect us with wider reality ([Fig 23](#)). Chakra means

'wheels of light' in the Sanskrit language of ancient India. The main ones are: The crown chakra on top of the head; brow (or 'third eye') chakra in the centre of the forehead; throat chakra; heart chakra in the centre of the chest; solar plexus chakra below the sternum; sacral chakra beneath the navel; and base chakra at the bottom of the spine. Each one has a particular function or functions. We feel anxiety and nervousness in the belly where the sacral chakra is located and this processes emotion that can affect the colon to give people 'the shits' or make them 'shit scared' when they are nervous. Chakras all play an important role, but the Mr and Mrs Big is the heart chakra which sits at the centre of the seven, above the chakras that connect us to the 'physical' and below those that connect with higher realms (or at least should). Here in the heart chakra we feel love, empathy and compassion – 'My heart goes out to you'. Those with closed hearts become literally 'heart-less' in their attitudes and behaviour (see Bill Gates). Native Americans portrayed Wetiko with what Paul Levy calls a 'frigid, icy heart, devoid of mercy' (see Bill Gates).



**Figure 23:** The chakra system which interpenetrates the human energy field. The heart chakra is the governor – or should be.

Wetiko trembles at the thought of heart energy which it cannot infiltrate. The frequency is too high. What it seeks to do instead is close the heart chakra vortex to block its perceptual and energetic influence. Psychopaths have 'hearts of stone' and emotionally-damaged people have 'heartache' and 'broken hearts'. The astonishing amount of heart disease is related to heart chakra

disruption with its fundamental connection to the 'physical' heart. Dr Tom Cowan has written an outstanding book challenging the belief that the heart is a pump and making the connection between the 'physical' and spiritual heart. Rudolph Steiner who was way ahead of his time said the same about the fallacy that the heart is a pump. *What?* The heart is not a pump? That's crazy, right? Everybody knows that. Read Cowan's *Human Heart, Cosmic Heart* and you will realise that the very idea of the heart as a pump is ridiculous when you see the evidence. How does blood in the feet so far from the heart get pumped horizontally up the body by the heart?? Cowan explains in the book the real reason why blood moves as it does. Our 'physical' heart is used to symbolise love when the source is really the heart vortex or spiritual heart which is our most powerful energetic connection to 'out there' expanded consciousness. That's why we feel *knowing* – intuitive knowing – in the centre of the chest. Knowing doesn't come from a process of thoughts leading to a conclusion. It is there in an instant all in one go. Our heart knows because of its connection to levels of awareness that *do* know. This is the meaning and source of intuition – intuitive *knowing*.

For the last more than 30 years of uncovering the global game and the nature of reality my heart has been my constant antenna for truth and accuracy. An American intelligence insider once said that I had quoted a disinformant in one of my books and yet I had only quoted the part that was true. He asked: 'How do you do that?' By using my heart antenna was the answer and anyone can do it. Heart-centred is how we are meant to be. With a closed heart chakra we withdraw into a closed mind and the bubble of five-sense reality. If you take a moment to focus your attention on the centre of your chest, picture a spinning wheel of light and see it opening and expanding. You will feel it happening, too, and perceptions of the heart like joy and love as the heart impacts on the mind as they interact. The more the chakra opens the more you will feel expressions of heart consciousness and as the process continues, and becomes part of you, insights and knowings will follow. An open

heart is connected to that level of awareness that knows all is *One*. You will see from its perspective that the fault-lines that divide us are only illusions to control us. An open heart does not process the illusions of race, creed and sexuality except as brief experiences for a consciousness that is all. Our heart does not see division, only unity (Figs 24 and 25). There's something else, too. Our hearts love to laugh. Mark Twain's quote that says 'The human race has one really effective weapon, and that is laughter' is really a reference to the heart which loves to laugh with the joy of knowing the true nature of infinite reality and that all the madness of human society is an illusion of the mind. Twain also said: 'Against the assault of laughter nothing can stand.' This is so true of Wetiko and the Cult. Their insecurity demands that they be taken seriously and their power and authority acknowledged and feared. We should do nothing of the sort. We should not get aggressive or fearful which their insecurity so desires. We should laugh in their face. Even in their no-face as police come over in their face-nappies and expect to be taken seriously. They don't take themselves seriously looking like that so why should we? Laugh in the face of intimidation. Laugh in the face of tyranny. You will see by its reaction that you have pressed all of its buttons. Wetiko does not know what to do in the face of laughter or when its targets refuse to concede their joy to fear. We have seen many examples during the 'Covid' hoax when people have expressed their energetic power and the string puppets of Wetiko retreat with their tail limp between their knees. Laugh – the world is bloody mad after all and if it's a choice between laughter and tears I know which way I'm going.





**Figure 24:** Head consciousness without the heart sees division and everything apart from everything else.



**Figure 25:** Heart consciousness sees everything as One.

## **'Vaccines' and the soul**

The foundation of Wetiko/Archon control of humans is the separation of incarnate five-sense mind from the infinite 'I' and closing the heart chakra where the True 'I' lives during a human life. The goal has been to achieve complete separation in both cases. I was interested therefore to read an account by a French energetic healer of what she said she experienced with a patient who had been given the 'Covid' vaccine. Genuine energy healers can sense information and consciousness fields at different levels of being which are referred to as 'subtle bodies'. She described treating the patient who later returned after having, without the healer's knowledge, two doses of the 'Covid vaccine'. The healer said:

I noticed immediately the change, very heavy energy emanating from [the] subtle bodies. The scariest thing was when I was working on the heart chakra, I connected with her soul: it was detached from the physical body, it had no contact and it was, as if it was floating in a state of total confusion: a damage to the consciousness that loses contact with the physical body, i.e. with our biological machine, there is no longer any communication between them.

I continued the treatment by sending light to the heart chakra, the soul of the person, but it seemed that the soul could no longer receive any light, frequency or energy. It was a very powerful experience for me. Then I understood that this substance is indeed used to detach consciousness so that this consciousness can no longer interact through this body that it possesses in life, where there is no longer any contact, no frequency, no light, no more energetic balance or mind.

This would create a human that is rudderless and at the extreme almost zombie-like operating with a fractional state of consciousness at the mercy of Wetiko. I was especially intrigued by what the healer said in the light of the prediction by the highly-informed Rudolf Steiner more than a hundred years ago. He said:

In the future, we will eliminate the soul with medicine. Under the pretext of a 'healthy point of view', there will be a vaccine by which the human body will be treated as soon as possible directly at birth, so that the human being cannot develop the thought of the existence of soul and Spirit. To materialistic doctors will be entrusted the task of removing the soul of humanity.

As today, people are vaccinated against this disease or that disease, so in the future, children will be vaccinated with a substance that can be produced precisely in such a way that people, thanks to this vaccination, will be immune to being subjected to the 'madness' of spiritual life. He would be extremely smart, but he would not develop a conscience, and that is the true goal of some materialistic circles.

Steiner said the vaccine would detach the physical body from the etheric body (subtle bodies) and 'once the etheric body is detached the relationship between the universe and the etheric body would become extremely unstable, and man would become an automaton'. He said 'the physical body of man must be polished on this Earth by spiritual will – so the vaccine becomes a kind of arymanique (Wetiko) force' and 'man can no longer get rid of a given materialistic feeling'. Humans would then, he said, become 'materialistic of constitution and can no longer rise to the spiritual'. I have been writing for years about DNA being a receiver-transmitter of information that connects us to other levels of reality and these 'vaccines' changing DNA can be likened to changing an antenna and what it can transmit and receive. Such a disconnection would clearly lead to changes in personality and perception. Steiner further predicted the arrival of AI. Big Pharma 'Covid vaccine' makers, expressions of Wetiko, are testing their DNA-manipulating evil on children as I write with a view to giving the 'vaccine' to babies. If it's a soul-body disconnecter – and I say that it is or can be – every child would be disconnected from 'soul' at birth and the 'vaccine' would create a closed system in which spiritual guidance from the greater self would play no part. This has been the ambition of Wetiko all

along. A Pentagon video from 2005 was leaked of a presentation explaining the development of vaccines to change behaviour by their effect on the brain. Those that believe this is not happening with the 'Covid' genetically-modifying procedure masquerading as a 'vaccine' should make an urgent appointment with Naivety Anonymous. Klaus Schwab wrote in 2018:

Neurotechnologies enable us to better influence consciousness and thought and to understand many activities of the brain. They include decoding what we are thinking in fine levels of detail through new chemicals and interventions that can influence our brains to correct for errors or enhance functionality.

The plan is clear and only the heart can stop it. With every heart that opens, every mind that awakens, Wetiko is weakened. Heart and love are far more powerful than head and hate and so nothing like a majority is needed to turn this around.

## **Beyond the Phantom**

Our heart is the prime target of Wetiko and so it must be the answer to Wetiko. We *are* our heart which is part of one heart, the infinite heart. Our heart is where the true self lives in a human life behind firewalls of five-sense illusion when an imposter takes its place – *Phantom Self*; but our heart waits patiently to be set free any time we choose to see beyond the Phantom, beyond Wetiko. A Wetikoed Phantom Self can wreak mass death and destruction while the love of forever is locked away in its heart. The time is here to unleash its power and let it sweep away the fear and despair that is Wetiko. Heart consciousness does not seek manipulated, censored, advantage for its belief or religion, its activism and desires. As an expression of the One it treats all as One with the same rights to freedom and opinion. Our heart demands fairness for itself no more than for others. From this unity of heart we can come together in mutual support and transform this Wetikoed world into what reality is meant to be – a place of love, joy, happiness, fairness, justice and freedom. Wetiko has another agenda and that's why the world is as

it is, but enough of this nonsense. Wetiko can't stay where hearts are open and it works so hard to keep them closed. Fear is its currency and its food source and love in its true sense has no fear. Why would love have fear when it knows it is *All That Is, Has Been, And Ever Can Be* on an eternal exploration of all possibility? Love in this true sense is not the physical attraction that passes for love. This can be an expression of it, yes, but Infinite Love, a love without condition, goes far deeper to the core of all being. It *is* the core of all being. Infinite reality was born from love beyond the illusions of the simulation. Love infinitely expressed is the knowing that all is One and the swiftly-passing experience of separation is a temporary hallucination. You cannot disconnect from Oneness; you can only *perceive* that you have and withdraw from its influence. This is the most important of all perception trickery by the mind parasite that is Wetiko and the foundation of all its potential for manipulation.

If we open our hearts, open the sluice gates of the mind, and redefine self-identity amazing things start to happen. Consciousness expands or contracts in accordance with self-identity. When true self is recognised as infinite awareness and label self – Phantom Self – is seen as only a series of brief experiences life is transformed. Consciousness expands to the extent that self-identity expands and everything changes. You see unity, not division, the picture, not the pixels. From this we can play the long game. No more is an experience something in and of itself, but a fleeting moment in the eternity of forever. Suddenly people in uniform and dark suits are no longer intimidating. Doing what your heart knows to be right is no longer intimidating and consequences for those actions take on the same nature of a brief experience that passes in the blink of an infinite eye. Intimidation is all in the mind. Beyond the mind there is no intimidation.

An open heart does not consider consequences for what it knows to be right. To do so would be to consider not doing what it knows to be right and for a heart in its power that is never an option. The Renegade Mind is really the Renegade Heart. Consideration of consequences will always provide a getaway car for the mind and

the heart doesn't want one. What is right in the light of what we face today is to stop cooperating with Wetiko in all its forms and to do it without fear or compromise. You cannot compromise with tyranny when tyranny always demands more until it has everything. Life is your perception and you are your destiny. Change your perception and you change your life. Change collective perception and we change the world.

*Come on people ... One human family, One heart, One goal ...*  
**FREEEEEEEDOM!**

We must settle for nothing less.

## Postscript

The big scare story as the book goes to press is the 'Indian' variant and the world is being deluged with propaganda about the 'Covid catastrophe' in India which mirrors in its lies and misrepresentations what happened in Italy before the first lockdown in 2020.

The *New York Post* published a picture of someone who had 'collapsed in the street from Covid' in India in April, 2021, which was actually taken during a gas leak in May, 2020. Same old, same old. Media articles in mid-February were asking why India had been so untouched by 'Covid' and then as their vaccine rollout gathered pace the alleged 'cases' began to rapidly increase. Indian 'Covid vaccine' maker Bharat Biotech was funded into existence by the Bill and Melinda Gates Foundation (the pair announced their divorce in May, 2021, which is a pity because they so deserve each other). The Indian 'Covid crisis' was ramped up by the media to terrify the world and prepare people for submission to still more restrictions. The scam that worked the first time was being repeated only with far more people seeing through the deceit. [Davidicke.com](http://Davidicke.com) and [Ickonic.com](http://Ickonic.com) have sought to tell the true story of what is happening by talking to people living through the Indian nightmare which has nothing to do with 'Covid'. We posted a letter from 'Alisha' in Pune who told a very different story to government and media mendacity. She said scenes of dying people and overwhelmed hospitals were designed to hide what was really happening – genocide and starvation. Alisha said that millions had already died of starvation during the ongoing lockdowns while government and media were lying and making it look like the 'virus':

Restaurants, shops, gyms, theatres, basically everything is shut. The cities are ghost towns. Even so-called 'essential' businesses are only open till 11am in the morning. You basically have just an hour to buy food and then your time is up.

Inter-state travel and even inter-district travel is banned. The cops wait at all major crossroads to question why you are traveling outdoors or to fine you if you are not wearing a mask.

The medical community here is also complicit in genocide, lying about hospitals being full and turning away people with genuine illnesses, who need immediate care. They have even created a shortage of oxygen cylinders.

This is the classic Cult modus operandi played out in every country. Alisha said that people who would not have a PCR test not testing for the 'virus' were being denied hospital treatment. She said the people hit hardest were migrant workers and those in rural areas. Most businesses employed migrant workers and with everything closed there were no jobs, no income and no food. As a result millions were dying of starvation or malnutrition. All this was happening under Prime Minister Narendra Modi, a 100-percent asset of the Cult, and it emphasises yet again the scale of pure anti-human evil we are dealing with. Australia banned its people from returning home from India with penalties for trying to do so of up to five years in jail and a fine of £37,000. The manufactured 'Covid' crisis in India was being prepared to justify further fascism in the West. Obvious connections could be seen between the Indian 'vaccine' programme and increased 'cases' and this became a common theme. The Seychelles, the most per capita 'Covid vaccinated' population in the world, went back into lockdown after a 'surge of cases'.

Long ago the truly evil Monsanto agricultural biotechnology corporation with its big connections to Bill Gates devastated Indian farming with genetically-modified crops. Human rights activist Gurcharan Singh highlighted the efforts by the Indian government to complete the job by destroying the food supply to hundreds of millions with 'Covid' lockdowns. He said that 415 million people at the bottom of the disgusting caste system (still going whatever they say) were below the poverty line and struggled to feed themselves every year. Now the government was imposing lockdown at just the

time to destroy the harvest. This deliberate policy was leading to mass starvation. People may reel back at the suggestion that a government would do that, but Wetiko-controlled 'leaders' are capable of any level of evil. In fact what is described in India is in the process of being instigated worldwide. The food chain and food supply are being targeted at every level to cause world hunger and thus control. Bill Gates is not the biggest owner of farmland in America for no reason and destroying access to food aids both the depopulation agenda and the plan for synthetic 'food' already being funded into existence by Gates. Add to this the coming hyper-inflation from the suicidal creation of fake 'money' in response to 'Covid' and the breakdown of container shipping systems and you have a cocktail that can only lead one way and is meant to. The Cult plan is to crash the entire system to 'build back better' with the Great Reset.

### **'Vaccine' transmission**

Reports from all over the world continue to emerge of women suffering menstrual and fertility problems after having the fake 'vaccine' and of the non-'vaccinated' having similar problems when interacting with the 'vaccinated'. There are far too many for 'coincidence' to be credible. We've had menopausal women getting periods, others having periods stop or not stopping for weeks, passing clots, sometimes the lining of the uterus, breast irregularities, and miscarriages (which increased by 400 percent in parts of the United States). Non-'vaccinated' men and children have suffered blood clots and nose bleeding after interaction with the 'vaccinated'. Babies have died from the effects of breast milk from a 'vaccinated' mother. Awake doctors – the small minority – speculated on the cause of non-'vaccinated' suffering the same effects as the 'vaccinated'. Was it nanotechnology in the synthetic substance transmitting frequencies or was it a straight chemical bioweapon that was being transmitted between people? I am not saying that some kind of chemical transmission is not one possible answer, but the foundation of all that the Cult does is frequency and



this is fertile ground for understanding how transmission can happen. American doctor Carrie Madej, an internal medicine physician and osteopath, has been practicing for the last 20 years, teaching medical students, and she says attending different meetings where the agenda for humanity was discussed. Madej, who operates out of Georgia, did not dismiss other possible forms of transmission, but she focused on frequency in search of an explanation for transmission. She said the Moderna and Pfizer 'vaccines' contained nano-lipid particles as a key component. This was a brand new technology never before used on humanity. 'They're using a nanotechnology which is pretty much little tiny computer bits ... nanobots or hydrogel.' Inside the 'vaccines' was 'this sci-fi kind of substance' which suppressed immune checkpoints to get into the cell. I referred to this earlier as the 'Trojan horse' technique that tricks the cell into opening a gateway for the self-replicating synthetic material and while the immune system is artificially suppressed the body has no defences. Madej said the substance served many purposes including an on-demand ability to 'deliver the payload' and using the nano 'computer bits' as biosensors in the body. 'It actually has the ability to accumulate data from your body, like your breathing, your respiration, thoughts, emotions, all kinds of things.'

She said the technology obviously has the ability to operate through Wi-Fi and transmit and receive energy, messages, frequencies or impulses. 'Just imagine you're getting this new substance in you and it can react to things all around you, the 5G, your smart device, your phones.' We had something completely foreign in the human body that had never been launched large scale at a time when we were seeing 5G going into schools and hospitals (plus the Musk satellites) and she believed the 'vaccine' transmission had something to do with this: '... if these people have this inside of them ... it can act like an antenna and actually transmit it outwardly as well.' The synthetic substance produced its own voltage and so it could have that kind of effect. This fits with my own contention that the nano receiver-transmitters are designed to connect people to the

Smart Grid and break the receiver-transmitter connection to expanded consciousness. That would explain the French energy healer's experience of the disconnection of body from 'soul' with those who have had the 'vaccine'. The nanobots, self-replicating inside the body, would also transmit the synthetic frequency which could be picked up through close interaction by those who have not been 'vaccinated'. Madej speculated that perhaps it was 5G and increased levels of other radiation that was causing the symptoms directly although interestingly she said that non-'vaccinated' patients had shown improvement when they were away from the 'vaccinated' person they had interacted with. It must be remembered that you can control frequency and energy with your mind and you can consciously create energetic barriers or bubbles with the mind to stop damaging frequencies from penetrating your field. American paediatrician Dr Larry Palevsky said the 'vaccine' was not a 'vaccine' and was never designed to protect from a 'viral' infection. He called it 'a massive, brilliant propaganda of genocide' because they didn't have to inject everyone to get the result they wanted. He said the content of the jabs was able to infuse any material into the brain, heart, lungs, kidneys, liver, sperm and female productive system. 'This is genocide; this is a weapon of mass destruction.' At the same time American colleges were banning students from attending if they didn't have this life-changing and potentially life-ending 'vaccine'. Class action lawsuits must follow when the consequences of this college fascism come to light. As the book was going to press came reports about fertility effects on sperm in 'vaccinated' men which would absolutely fit with what I have been saying and hospitals continued to fill with 'vaccine' reactions. Another question is what about transmission via blood transfusions? The NHS has extended blood donation restrictions from seven days after a 'Covid vaccination' to 28 days after even a sore arm reaction.

I said in the spring of 2020 that the then touted 'Covid vaccine' would be ongoing each year like the flu jab. A year later Pfizer CEO, the appalling Albert Bourla, said people would 'likely' need a 'booster dose' of the 'vaccine' within 12 months of getting 'fully

vaccinated' and then a yearly shot. 'Variants will play a key role', he said confirming the point. Johnson & Johnson CEO Alex Gorsky also took time out from his 'vaccine' disaster to say that people may need to be vaccinated against 'Covid-19' each year. UK Health Secretary, the psychopath Matt Hancock, said additional 'boosters' would be available in the autumn of 2021. This is the trap of the 'vaccine passport'. The public will have to accept every last 'vaccine' they introduce, including for the fake 'variants', or it would cease to be valid. The only other way in some cases would be continuous testing with a test not testing for the 'virus' and what is on the swabs constantly pushed up your nose towards the brain every time?

### **'Vaccines' changing behaviour**

I mentioned in the body of the book how I believed we would see gathering behaviour changes in the 'vaccinated' and I am already hearing such comments from the non-'vaccinated' describing behaviour changes in friends, loved ones and work colleagues. This will only increase as the self-replicating synthetic material and nanoparticles expand in body and brain. An article in the *Guardian* in 2016 detailed research at the University of Virginia in Charlottesville which developed a new method for controlling brain circuits associated with complex animal behaviour. The method, dubbed 'magnetogenetics', involves genetically-engineering a protein called ferritin, which stores and releases iron, to create a magnetised substance – 'Magneto' – that can activate specific groups of nerve cells from a distance. This is claimed to be an advance on other methods of brain activity manipulation known as optogenetics and chemogenetics (the Cult has been developing methods of brain control for a long time). The ferritin technique is said to be non-invasive and able to activate neurons 'rapidly and reversibly'. In other words, human thought and perception. The article said that earlier studies revealed how nerve cell proteins 'activated by heat and mechanical pressure can be genetically engineered so that they become sensitive to radio waves and magnetic fields, by attaching them to an iron-storing protein called ferritin, or to inorganic

paramagnetic particles'. Sensitive to radio waves and magnetic fields? You mean like 5G, 6G and 7G? This is the human-AI Smart Grid hive mind we are talking about. The *Guardian* article said:

... the researchers injected Magneto into the striatum of freely behaving mice, a deep brain structure containing dopamine-producing neurons that are involved in reward and motivation, and then placed the animals into an apparatus split into magnetised and non-magnetised sections.

Mice expressing Magneto spent far more time in the magnetised areas than mice that did not, because activation of the protein caused the striatal neurons expressing it to release dopamine, so that the mice found being in those areas rewarding. This shows that Magneto can remotely control the firing of neurons deep within the brain, and also control complex behaviours.

Make no mistake this basic methodology will be part of the 'Covid vaccine' cocktail and using magnetics to change brain function through electromagnetic field frequency activation. The Pentagon is developing a 'Covid vaccine' using ferritin. Magnetics would explain changes in behaviour and why videos are appearing across the Internet as I write showing how magnets stick to the skin at the point of the 'vaccine' shot. Once people take these 'vaccines' anything becomes possible in terms of brain function and illness which will be blamed on 'Covid-19' and 'variants'. Magnetic field manipulation would further explain why the non-'vaccinated' are reporting the same symptoms as the 'vaccinated' they interact with and why those symptoms are reported to decrease when not in their company. Interestingly 'Magneto', a 'mutant', is a character in the Marvel Comic *X-Men* stories with the ability to manipulate magnetic fields and he believes that mutants should fight back against their human oppressors by any means necessary. The character was born Erik Lehnsherr to a Jewish family in Germany.

## **Cult-controlled courts**

The European Court of Human Rights opened the door for mandatory 'Covid-19 vaccines' across the continent when it ruled in a Czech Republic dispute over childhood immunisation that legally

enforced vaccination could be 'necessary in a democratic society'. The 17 judges decided that compulsory vaccinations did not breach human rights law. On the face of it the judgement was so inverted you gasp for air. If not having a vaccine infused into your body is not a human right then what is? Ah, but they said human rights law which has been specifically written to delete all human rights at the behest of the state (the Cult). Article 8 of the European Convention on Human Rights relates to the right to a private life. The crucial word here is '*except*':

There shall be no interference by a public authority with the exercise of this right EXCEPT such as is in accordance with the law and is necessary in a democratic society in the interests of national security, public safety or the economic wellbeing of the country, for the prevention of disorder or crime, for the protection of health or morals, or for the protection of the rights and freedoms of others [My emphasis].

No interference *except* in accordance with the law means there *are* no 'human rights' *except* what EU governments decide you can have at their behest. 'As is necessary in a democratic society' explains that reference in the judgement and 'in the interests of national security, public safety or the economic well-being of the country, for the prevention of disorder or crime, for the protection of health or morals, or for the protection of the rights and freedoms of others' gives the EU a coach and horses to ride through 'human rights' and scatter them in all directions. The judiciary is not a check and balance on government extremism; it is a vehicle to enforce it. This judgement was almost laughably predictable when the last thing the Cult wanted was a decision that went against mandatory vaccination. Judges rule over and over again to benefit the system of which they are a part. Vaccination disputes that come before them are invariably delivered in favour of doctors and authorities representing the view of the state which owns the judiciary. Oh, yes, and we have even had calls to stop putting 'Covid-19' on death certificates within 28 days of a 'positive test' because it is claimed the practice makes the 'vaccine' appear not to work. They are laughing at you.

The scale of madness, inhumanity and things to come was highlighted when those not 'vaccinated' for 'Covid' were refused evacuation from the Caribbean island of St Vincent during massive volcanic eruptions. Cruise ships taking residents to the safety of another island allowed only the 'vaccinated' to board and the rest were left to their fate. Even in life and death situations like this we see 'Covid' stripping people of their most basic human instincts and the insanity is even more extreme when you think that fake 'vaccine'-makers are not even claiming their body-manipulating concoctions stop 'infection' and 'transmission' of a 'virus' that doesn't exist. St Vincent Prime Minister Ralph Gonsalves said: 'The chief medical officer will be identifying the persons already vaccinated so that we can get them on the ship.' Note again the power of the chief medical officer who, like Whitty in the UK, will be answering to the World Health Organization. This is the Cult network structure that has overridden politicians who 'follow the science' which means doing what WHO-controlled 'medical officers' and 'science advisers' tell them. Gonsalves even said that residents who were 'vaccinated' after the order so they could board the ships would still be refused entry due to possible side effects such as 'wooziness in the head'. The good news is that if they were woozy enough in the head they could qualify to be prime minister of St Vincent.

## **Microchipping freedom**

The European judgement will be used at some point to justify moves to enforce the 'Covid' DNA-manipulating procedure. Sandra Ro, CEO of the Global Blockchain Business Council, told a World Economic Forum event that she hoped 'vaccine passports' would help to 'drive forced consent and standardisation' of global digital identity schemes: 'I'm hoping with the desire and global demand for some sort of vaccine passport – so that people can get travelling and working again – [it] will drive forced consent, standardisation, and frankly, cooperation across the world.' The lady is either not very bright, or thoroughly mendacious, to use the term 'forced consent'.

You do not 'consent' if you are forced – you *submit*. She was describing what the plan has been all along and that's to enforce a digital identity on every human without which they could not function. 'Vaccine passports' are opening the door and are far from the end goal. A digital identity would allow you to be tracked in everything you do in cyberspace and this is the same technique used by Cult-owned China to enforce its social credit system of total control. The ultimate 'passport' is planned to be a microchip as my books have warned for nearly 30 years. Those nice people at the Pentagon working for the Cult-controlled Defense Advanced Research Projects Agency (DARPA) claimed in April, 2021, they have developed a microchip inserted under the skin to detect 'asymptomatic Covid-19 infection' before it becomes an outbreak and a 'revolutionary filter' that can remove the 'virus' from the blood when attached to a dialysis machine. The only problems with this are that the 'virus' does not exist and people transmitting the 'virus' with no symptoms is brain-numbing bullshit. This is, of course, not a ruse to get people to be microchipped for very different reasons. DARPA also said it was producing a one-stop 'vaccine' for the 'virus' and all 'variants'. One of the most sinister organisations on Planet Earth is doing this? Better have it then. These people are insane because Wetiko that possesses them is insane.

Researchers from the Salk Institute in California announced they have created an embryo that is part human and part monkey. My books going back to the 1990s have exposed experiments in top secret underground facilities in the United States where humans are being crossed with animal and non-human 'extraterrestrial' species. They are now easing that long-developed capability into the public arena and there is much more to come given we are dealing with psychiatric basket cases. Talking of which – Elon Musk's scientists at Neuralink trained a monkey to play Pong and other puzzles on a computer screen using a joystick and when the monkey made the correct move a metal tube squirted banana smoothie into his mouth which is the basic technique for training humans into unquestioning compliance. Two Neuralink chips were in the monkey's skull and

more than 2,000 wires 'fanned out' into its brain. Eventually the monkey played a video game purely with its brain waves. Psychopathic narcissist Musk said the 'breakthrough' was a step towards putting Neuralink chips into human skulls and merging minds with artificial intelligence. *Exactly*. This man is so dark and Cult to his DNA.

## **World Economic Fascism (WEF)**

The World Economic Forum is telling you the plan by the statements made at its many and various events. Cult-owned fascist YouTube CEO Susan Wojcicki spoke at the 2021 WEF Global Technology Governance Summit (see the name) in which 40 governments and 150 companies met to ensure 'the responsible design and deployment of emerging technologies'. Orwellian translation: 'Ensuring the design and deployment of long-planned technologies will advance the Cult agenda for control and censorship.' Freedom-destroyer and Nuremberg-bound Wojcicki expressed support for tech platforms like hers to censor content that is 'technically legal but could be harmful'. Who decides what is 'harmful'? She does and they do. 'Harmful' will be whatever the Cult doesn't want people to see and we have legislation proposed by the UK government that would censor content on the basis of 'harm' no matter if the information is fair, legal and provably true. Make that *especially* if it is fair, legal and provably true. Wojcicki called for a global coalition to be formed to enforce content moderation standards through automated censorship. This is a woman and mega-censor so self-deluded that she shamelessly accepted a 'free expression' award – *Wojcicki* – in an event sponsored by her own *YouTube*. They have no shame and no self-awareness.

You know that 'Covid' is a scam and Wojcicki a Cult operative when YouTube is censoring medical and scientific opinion purely on the grounds of whether it supports or opposes the Cult 'Covid' narrative. Florida governor Ron DeSantis compiled an expert panel with four professors of medicine from Harvard, Oxford, and Stanford Universities who spoke against forcing children and



vaccinated people to wear masks. They also said there was no proof that lockdowns reduced spread or death rates of 'Covid-19'. Cult-gofer Wojcicki and her YouTube deleted the panel video 'because it included content that contradicts the consensus of local and global health authorities regarding the efficacy of masks to prevent the spread of Covid-19'. This 'consensus' refers to what the Cult tells the World Health Organization to say and the WHO tells 'local health authorities' to do. Wojcicki knows this, of course. The panellists pointed out that censorship of scientific debate was responsible for deaths from many causes, but Wojcicki couldn't care less. She would not dare go against what she is told and as a disgrace to humanity she wouldn't want to anyway. The UK government is seeking to pass a fascist 'Online Safety Bill' to specifically target with massive fines and other means non-censored video and social media platforms to make them censor 'lawful but harmful' content like the Cult-owned Facebook, Twitter, Google and YouTube. What is 'lawful but harmful' would be decided by the fascist Blair-created Ofcom.

Another WEF obsession is a cyber-attack on the financial system and this is clearly what the Cult has planned to take down the bank accounts of everyone – except theirs. Those that think they have enough money for the Cult agenda not to matter to them have got a big lesson coming if they continue to ignore what is staring them in the face. The World Economic Forum, funded by Gates and fronted by Klaus Schwab, announced it would be running a 'simulation' with the Russian government and global banks of just such an attack called Cyber Polygon 2021. What they simulate – as with the 'Covid' Event 201 – they plan to instigate. The WEF is involved in a project with the Cult-owned Carnegie Endowment for International Peace called the WEF-Carnegie Cyber Policy Initiative which seeks to merge Wall Street banks, 'regulators' (I love it) and intelligence agencies to 'prevent' (arrange and allow) a cyber-attack that would bring down the global financial system as long planned by those that control the WEF and the Carnegie operation. The Carnegie Endowment for International Peace sent an instruction to First World

War US President Woodrow Wilson not to let the war end before society had been irreversibly transformed.

## **The Wuhan lab diversion**

As I close, the Cult-controlled authorities and lapdog media are systematically pushing 'the virus was released from the Wuhan lab' narrative. There are two versions – it happened by accident and it happened on purpose. Both are nonsense. The perceived existence of the never-shown-to-exist 'virus' is vital to sell the impression that there is actually an infective agent to deal with and to allow the endless potential for terrifying the population with 'variants' of a 'virus' that does not exist. The authorities at the time of writing are going with the 'by accident' while the alternative media is promoting the 'on purpose'. Cable news host Tucker Carlson who has questioned aspects of lockdown and 'vaccine' compulsion has bought the Wuhan lab story. 'Everyone now agrees' he said. Well, I don't and many others don't and the question is *why* does the system and its media suddenly 'agree'? When the media moves as one unit with a narrative it is always a lie – witness the hour by hour mendacity of the 'Covid' era. Why would this Cult-owned combination which has unleashed lies like machine gun fire suddenly 'agree' to tell the truth??

Much of the alternative media is buying the lie because it fits the conspiracy narrative, but it's the *wrong* conspiracy. The real conspiracy is that *there is no virus* and that is what the Cult is desperate to hide. The idea that the 'virus' was released by accident is ludicrous when the whole 'Covid' hoax was clearly long-planned and waiting to be played out as it was so fast in accordance with the Rockefeller document and Event 201. So they prepared everything in detail over decades and then sat around strumming their fingers waiting for an 'accidental' release from a bio-lab? *What??* It's crazy. Then there's the 'on purpose' claim. You want to circulate a 'deadly virus' and hide the fact that you've done so and you release it down the street from the highest-level bio-lab in China? I repeat – *What??*

You would release it far from that lab to stop any association being made. But, no, we'll do it in a place where the connection was certain to be made. Why would you need to scam 'cases' and 'deaths' and pay hospitals to diagnose 'Covid-19' if you had a real 'virus'? What are sections of the alternative media doing believing this crap? Where were all the mass deaths in Wuhan from a 'deadly pathogen' when the recovery to normal life after the initial propaganda was dramatic in speed? Why isn't the 'deadly pathogen' now circulating all over China with bodies in the street? Once again we have the technique of tell them what they want to hear and they will likely believe it. The alternative media has its 'conspiracy' and with Carlson it fits with his 'China is the danger' narrative over years. China *is* a danger as a global Cult operations centre, but not for this reason. The Wuhan lab story also has the potential to instigate conflict with China when at some stage the plan is to trigger a Problem-Reaction-Solution confrontation with the West. Question everything – *everything* – and especially when the media agrees on a common party line.

### **Third wave ... fourth wave ... fifth wave ...**

As the book went into production the world was being set up for more lockdowns and a 'third wave' supported by invented 'variants' that were increasing all the time and will continue to do so in public statements and computer programs, but not in reality. India became the new Italy in the 'Covid' propaganda campaign and we were told to be frightened of the new 'Indian strain'. Somehow I couldn't find it within myself to do so. A document produced for the UK government entitled 'Summary of further modelling of easing of restrictions – Roadmap Step 2' declared that a third wave was inevitable (of course when it's in the script) and it would be the fault of children and those who refuse the health-destroying fake 'Covid vaccine'. One of the computer models involved came from the Cult-owned *Imperial College* and the other from Warwick University which I wouldn't trust to tell me the date in a calendar factory. The document states that both models presumed extremely high uptake

of the 'Covid vaccines' and didn't allow for 'variants'. The document states: 'The resurgence is a result of some people (mostly children) being ineligible for vaccination; others choosing not to receive the vaccine; and others being vaccinated but not perfectly protected.' The mendacity takes the breath away. Okay, blame those with a brain who won't take the DNA-modifying shots and put more pressure on children to have it as 'trials' were underway involving children as young as six months with parents who give insanity a bad name. Massive pressure is being put on the young to have the fake 'vaccine' and child age consent limits have been systematically lowered around the world to stop parents intervening. Most extraordinary about the document was its claim that the 'third wave' would be driven by 'the resurgence in both hospitalisations and deaths ... dominated by *those that have received two doses of the vaccine*, comprising around 60-70% of the wave respectively'. The predicted peak of the 'third wave' suggested 300 deaths per day with 250 of them *fully 'vaccinated' people*. How many more lies do acquiescers need to be told before they see the obvious? Those who took the job to 'protect themselves' are projected to be those who mostly get sick and die? So what's in the 'vaccine'? The document went on:

It is possible that a summer of low prevalence could be followed by substantial increases in incidence over the following autumn and winter. Low prevalence in late summer should not be taken as an indication that SARS-CoV-2 has retreated or that the population has high enough levels of immunity to prevent another wave.

They are telling you the script and while many British people believed 'Covid' restrictions would end in the summer of 2021 the government was preparing for them to be ongoing. Authorities were awarding contracts for 'Covid marshals' to police the restrictions with contracts starting in July, 2021, and going through to January 31st, 2022, and the government was advertising for 'Media Buying Services' to secure media propaganda slots worth a potential £320 million for 'Covid-19 campaigns' with a contract not ending until March, 2022. The recipient – via a list of other front companies – was reported to be American media marketing giant Omnicom Group

Inc. While money is no object for 'Covid' the UK waiting list for all other treatment – including life-threatening conditions – passed 4.5 million. Meantime the Cult is seeking to control all official 'inquiries' to block revelations about what has really been happening and why. It must not be allowed to – we need Nuremberg jury trials in every country. The cover-up doesn't get more obvious than appointing ultra-Zionist professor Philip Zelikow to oversee two dozen US virologists, public health officials, clinicians, former government officials and four American 'charitable foundations' to 'learn the lessons' of the 'Covid' debacle. The personnel will be those that created and perpetuated the 'Covid' lies while Zelikow is the former executive director of the 9/11 Commission who ensured that the truth about those attacks never came out and produced a report that must be among the most mendacious and manipulative documents ever written – see *The Trigger* for the detailed exposure of the almost unimaginable 9/11 story in which Sabbatians can be found at every level.

## **Passive no more**

People are increasingly challenging the authorities with amazing numbers of people taking to the streets in London well beyond the ability of the Face-Nappies to stop them. Instead the Nappies choose situations away from the mass crowds to target, intimidate, and seek to promote the impression of 'violent protestors'. One such incident happened in London's Hyde Park. Hundreds of thousands walking through the streets in protest against 'Covid' fascism were ignored by the Cult-owned BBC and most of the rest of the mainstream media, but they delighted in reporting how police were injured in 'clashes with protestors'. The truth was that a group of people gathered in Hyde Park at the end of one march when most had gone home and they were peacefully having a good time with music and chat. Face-Nappies who couldn't deal with the full-march crowd then waded in with their batons and got more than they bargained for. Instead of just standing for this criminal brutality the crowd used their numerical superiority to push the Face-Nappies out of the

park. Eventually the Nappies turned and ran. Unfortunately two or three idiots in the crowd threw drink cans striking two officers which gave the media and the government the image they wanted to discredit the 99.9999 percent who were peaceful. The idiots walked straight into the trap and we must always be aware of potential agent provocateurs used by the authorities to discredit their targets.

This response from the crowd – the can people apart – must be a turning point when the public no longer stand by while the innocent are arrested and brutally attacked by the Face-Nappies. That doesn't mean to be violent, that's the last thing we need. We'll leave the violence to the Face-Nappies and government. But it does mean that when the Face-Nappies use violence against peaceful people the numerical superiority is employed to stop them and make citizen's arrests or Common Law arrests for a breach of the peace. The time for being passive in the face of fascism is over.

We are the many, they are the few, and we need to make that count before there is no freedom left and our children and grandchildren face an ongoing fascist nightmare.

*COME ON PEOPLE – IT'S TIME.*

### **One final thought ...**

The power of love  
A force from above  
Cleaning my soul  
Flame on burn desire  
Love with tongues of fire  
Purge the soul  
Make love your goal

I'll protect you from the hooded claw  
Keep the vampires from your door  
When the chips are down I'll be around  
With my undying, death-defying  
Love for you

Envy will hurt itself  
Let yourself be beautiful  
Sparkling love, flowers  
And pearls and pretty girls  
Love is like an energy  
Rushin' rushin' inside of me

This time we go sublime  
Lovers entwine, divine, divine,  
Love is danger, love is pleasure  
Love is pure – the only treasure

I'm so in love with you  
Purge the soul  
Make love your goal

The power of love  
A force from above  
Cleaning my soul  
The power of love  
A force from above  
A sky-scraping dove

Flame on burn desire  
Love with tongues of fire  
Purge the soul  
Make love your goal

**Frankie Goes To Hollywood**



## APPENDIX

### **Cowan-Kaufman-Morell Statement on Virus Isolation (SOVI)**

*Isolation: The action of isolating; the fact or condition of being isolated or standing alone; separation from other things or persons; solitariness*

Oxford English Dictionary

The controversy over whether the SARS-CoV-2 virus has ever been isolated or purified continues. However, using the above definition, common sense, the laws of logic and the dictates of science, any unbiased person must come to the conclusion that the SARS-CoV-2 virus has never been isolated or purified. As a result, no confirmation of the virus' existence can be found. The logical, common sense, and scientific consequences of this fact are:

- the structure and composition of something not shown to exist can't be known, including the presence, structure, and function of any hypothetical spike or other proteins;
- the genetic sequence of something that has never been found can't be known;
- "variants" of something that hasn't been shown to exist can't be known;
- it's impossible to demonstrate that SARS-CoV-2 causes a disease called Covid-19.

In as concise terms as possible, here's the proper way to isolate, characterize and demonstrate a new virus. First, one takes samples (blood, sputum, secretions) from many people (e.g. 500) with symptoms which are unique and specific enough to characterize an illness. Without mixing these samples with ANY tissue or products that also contain genetic material, the virologist macerates, filters and ultracentrifuges i.e. *purifies* the specimen. This common virology technique, done for decades to isolate bacteriophages<sup>1</sup> and so-called giant viruses in every virology lab, then allows the virologist to demonstrate with electron microscopy thousands of identically sized and shaped particles. These particles are the isolated and purified virus.

These identical particles are then checked for uniformity by physical and/or microscopic techniques. Once the purity is determined, the particles may be further characterized. This would include examining the structure, morphology, and chemical composition of the particles. Next, their genetic makeup is characterized by extracting the genetic material directly from the purified particles and using genetic-sequencing techniques, such as Sanger sequencing, that have also been around for decades. Then one does an analysis to confirm that these uniform particles are exogenous (outside) in origin as a virus is conceptualized to be, and not the normal breakdown products of dead and dying tissues.<sup>2</sup> (As of May 2020, we know that virologists have no way to determine whether the particles they're seeing are viruses or just normal breakdown products of dead and dying tissues.)<sup>3</sup>

---

1 Isolation, characterization and analysis of bacteriophages from the haloalkaline lake Elmenteita, Kenya Julia Khayeli Akhwale et al, PLOS One, Published: April 25, 2019.  
<https://journals.plos.org/plosone/article?id=10.1371/journal.pone.0215734> – accessed 2/15/21

---

2 "Extracellular Vesicles Derived From Apoptotic Cells: An Essential Link Between Death and Regeneration," Maojiao Li et al, Frontiers in Cell and Developmental Biology, 2020 October 2.  
<https://www.frontiersin.org/articles/10.3389/fcell.2020.573511/full> – accessed 2/15/21

If we have come this far then we have fully isolated, characterized, and genetically sequenced an exogenous virus particle. However, we still have to show it is causally related to a disease. This is carried out by exposing a group of healthy subjects (animals are usually used) to this isolated, purified virus in the manner in which the disease is thought to be transmitted. If the animals get sick with the same disease, as confirmed by clinical and autopsy findings, one has now shown that the virus actually causes a disease. This demonstrates infectivity and transmission of an infectious agent.

None of these steps has even been attempted with the SARS-CoV-2 virus, nor have all these steps been successfully performed for any so-called pathogenic virus. Our research indicates that a single study showing these steps does not exist in the medical literature.

Instead, since 1954, virologists have taken unpurified samples from a relatively few people, often less than ten, with a similar disease. They then minimally process this sample and inoculate this unpurified sample onto tissue culture containing usually four to six other types of material – all of which contain identical genetic material as to what is called a “virus.” The tissue culture is starved and poisoned and naturally disintegrates into many types of particles, some of which contain genetic material. Against all common sense, logic, use of the English language and scientific integrity, this process is called “virus isolation.” This brew containing fragments of genetic material from many sources is then subjected to genetic analysis, which then creates in a computer-simulation process the alleged sequence of the alleged virus, a so called in silico genome. At no time is an actual virus confirmed by electron microscopy. At no time is a genome extracted and sequenced from an actual virus. This is scientific fraud.

The observation that the unpurified specimen — inoculated onto tissue culture along with toxic antibiotics, bovine fetal tissue, amniotic fluid and other tissues — destroys the kidney tissue onto which it is inoculated is given as evidence of the virus' existence and pathogenicity. This is scientific fraud.

From now on, when anyone gives you a paper that suggests the SARS-CoV-2 virus has been isolated, please check the methods sections. If the researchers used Vero cells or any other culture method, you know that their process was not isolation. You will hear the following excuses for why actual isolation isn't done:

1. There were not enough virus particles found in samples from patients to analyze.
2. Viruses are intracellular parasites; they can't be found outside the cell in this manner.

If No. 1 is correct, and we can't find the virus in the sputum of sick people, then on what evidence do we think the virus is dangerous or even lethal? If No. 2 is correct, then how is the virus spread from person to person? We are told it emerges from the cell to infect others. Then why isn't it possible to find it?

Finally, questioning these virology techniques and conclusions is not some distraction or divisive issue. Shining the light on this truth is essential to stop this terrible fraud that humanity is confronting. For, as we now know, if the virus has never been isolated, sequenced or shown to cause illness, if the virus is imaginary, then why are we wearing masks, social distancing and putting the whole world into prison?

Finally, if pathogenic viruses don't exist, then what is going into those injectable devices erroneously called "vaccines," and what is their purpose? This scientific question is the most urgent and relevant one of our time.

We are correct. The SARS-CoV2 virus does not exist.

Sally Fallon Morell, MA

Dr. Thomas Cowan, MD

Dr. Andrew Kaufman, MD

# Bibliography

- Alinsky, Saul:** *Rules for Radicals* (Vintage, 1989)
- Antelman, Rabbi Marvin:** *To Eliminate the Opiate* (Zahavia, 1974)
- Bastardi, Joe:** *The Climate Chronicles* (Relentless Thunder Press, 2018)
- Cowan, Tom:** *Human Heart, Cosmic Heart* (Chelsea Green Publishing, 2016)
- Cowan, Tom, and Fallon Morell, Sally:** *The Contagion Myth* (Skyhorse Publishing, 2020)
- Forbes, Jack D:** *Columbus And Other Cannibals – The Wetiko Disease of Exploitation, Imperialism, and Terrorism* (Seven Stories Press, 2008 – originally published in 1979)
- Gates, Bill:** *How to Avoid a Climate Disaster: The Solutions We Have and the Breakthroughs We Need* (Allen Lane, 2021)
- Huxley, Aldous:** *Brave New World* (Chatto & Windus, 1932)
- Köhnlein, Dr Claus, and Engelbrecht, Torsten:** *Virus Mania* (emu-Verlag, Lahnstein, 2020)
- Lanza, Robert, and Berman, Bob:** *Biocentrism* (BenBella Books, 2010)
- Lash, John Lamb:** *Not In His Image* (Chelsea Green Publishing, 2006)
- Lester, Dawn, and Parker, David:** *What Really Makes You Ill – Why everything you thought you knew about disease is wrong* (Independently Published, 2019)
- Levy, Paul:** *Dispelling Wetiko, Breaking the Spell of Evil* (North Atlantic Books, 2013)
- Marx, Karl:** *A World Without Jews* (Philosophical Library, first edition, 1959)
- Mullis, Kary:** *Dancing Naked in the Mine Field* (Bloomsbury, 1999)
- O'Brien, Cathy:** *Trance-Formation of America* (Reality Marketing, 1995)
- Scholem, Gershon:** *The Messianic Idea in Judaism* (Schocken Books, 1994)
- Schwab, Klaus, and Davis, Nicholas:** *Shaping the Future of the Fourth Industrial Revolution: A guide to building a better world* (Penguin Books, 2018)
- Schwab, Klaus:** *The Great Reset* (Agentur Schweiz, 2020)
- Sunstein, Cass and Thaler, Richard:** *Nudge: Improving Decisions About Health, Wealth, and Happiness* (Penguin, 2009)
- Swan, Shanna:** *Count Down: How Our Modern World Is Threatening Sperm Counts, Altering Male and Female Reproductive Development and Imperiling the Future of the Human Race* (Scribner, 2021)
- Tegmark, Max:** *Our Mathematical Universe: My Quest for the Ultimate Nature of Reality* (Penguin, 2015)
- Velikovsky, Immanuel:** *Worlds in Collision* (Paradigma, 2009)

**Wilton, Robert:** *The Last Days of the Romanovs* (Blurb, 2018, first published 1920)

# Index

## A

### **abusive relationships**

blaming themselves, abused as [ref1](#)

children [ref1](#), [ref2](#), [ref3](#), [ref4](#), [ref5](#), [ref6](#), [ref7](#), [ref8](#), [ref9](#), [ref10](#)

conspiracy theories [ref1](#)

domestic abuse [ref1](#), [ref2](#)

economic abuse and dependency [ref1](#)

isolation [ref1](#)

physical abuse [ref1](#)

psychological abuse [ref1](#)

signs of abuse [ref1](#)

### **addiction**

alcoholism [ref1](#)

frequencies [ref1](#)

substance abuse [ref1](#), [ref2](#)

technology [ref1](#), [ref2](#), [ref3](#)

**Adelson, Sheldon** [ref1](#), [ref2](#), [ref3](#)

**Agenda 21/Agenda 2030 (UN)** [ref1](#), [ref2](#), [ref3](#), [ref4](#)

**AIDs/HIV** [ref1](#)

causal link between HIV and AIDs [ref1](#), [ref2](#)

retroviruses [ref1](#)

testing [ref1](#), [ref2](#)

trial-run for Covid-19, as [ref1](#), [ref2](#)

**aliens/extraterrestrials** [ref1](#), [ref2](#)

**aluminium** [ref1](#)

**Amazon** [ref1](#), [ref2](#), [ref3](#)



**amplification cycles** [ref1](#), [ref2](#)  
**anaphylactic shock** [ref1](#), [ref2](#), [ref3](#), [ref4](#)  
**animals** [ref1](#), [ref2](#), [ref3](#)  
**antibodies** [ref1](#), [ref2](#), [ref3](#), [ref4](#), [ref5](#)  
**Antifa** [ref1](#), [ref2](#), [ref3](#), [ref4](#)  
**antigens** [ref1](#), [ref2](#)  
**anti-Semitism** [ref1](#), [ref2](#), [ref3](#)  
**Archons** [ref1](#), [ref2](#)  
    consciousness [ref1](#), [ref2](#), [ref3](#)  
    energy [ref1](#), [ref2](#), [ref3](#)  
    ennoia [ref1](#)  
    genetic manipulation [ref1](#), [ref2](#)  
    inversion [ref1](#), [ref2](#), [ref3](#)  
    lockdowns [ref1](#)  
    money [ref1](#)  
    radiation [ref1](#)  
    religion [ref1](#), [ref2](#)  
    technology [ref1](#), [ref2](#), [ref3](#)  
    Wetiko factor [ref1](#), [ref2](#), [ref3](#), [ref4](#)  
**artificial intelligence (AI)** [ref1](#)  
**army made up of robots** [ref1](#), [ref2](#)  
    Human 2.0 [ref1](#), [ref2](#)  
    Internet [ref1](#)  
    MHRA [ref1](#)  
    Morgellons fibres [ref1](#), [ref2](#)  
    Smart Grid [ref1](#)  
    Wetiko factor [ref1](#)  
**asymptomatic, Covid-19 as** [ref1](#), [ref2](#), [ref3](#)  
**aviation industry** [ref1](#)

## **B**

**banking, finance and money** [ref1](#), [ref2](#), [ref3](#)

2008 crisis [ref1](#), [ref2](#)

boom and bust [ref1](#)

cashless digital money systems [ref1](#)

central banks [ref1](#)

credit [ref1](#)

digital currency [ref1](#)

fractional reserve lending [ref1](#)

Great Reset [ref1](#)

guaranteed income [ref1](#), [ref2](#), [ref3](#)

Human 2.0 [ref1](#)

incomes, destruction of [ref1](#), [ref2](#)

interest [ref1](#)

one per cent [ref1](#), [ref2](#)

scams [ref1](#)

**BBC** [ref1](#), [ref2](#), [ref3](#), [ref4](#), [ref5](#), [ref6](#), [ref7](#), [ref8](#)

**Becker-Phelps, Leslie** [ref1](#)

**Behavioural Insights Team (BIT) (Nudge Unit)** [ref1](#), [ref2](#), [ref3](#)

**behavioural scientists *and* psychologists, advice from** [ref1](#), [ref2](#)

**Bezos, Jeff** [ref1](#), [ref2](#), [ref3](#), [ref4](#)

**Biden, Hunter** [ref1](#)

**Biden, Joe** [ref1](#), [ref2](#), [ref3](#), [ref4](#), [ref5](#), [ref6](#), [ref7](#), [ref8](#), [ref9](#), [ref10](#), [ref11](#),  
[ref12](#), [ref13](#), [ref14](#), [ref15](#), [ref16](#), [ref17](#)

**Big Pharma**

cholesterol [ref1](#)

health professionals [ref1](#), [ref2](#)

immunity from prosecution in US [ref1](#)

vaccines [ref1](#), [ref2](#), [ref3](#), [ref4](#), [ref5](#), [ref6](#), [ref7](#), [ref8](#)

Wetiko factor [ref1](#), [ref2](#)

WHO [ref1](#), [ref2](#), [ref3](#)

**Bill and Melinda Gates Foundation** [ref1](#), [ref2](#), [ref3](#), [ref4](#), [ref5](#), [ref6](#),  
[ref7](#)

**billionaires** [ref1](#), [ref2](#), [ref3](#), [ref4](#), [ref5](#), [ref6](#), [ref7](#), [ref8](#), [ref9](#) [ref10](#), [ref11](#)

**bird flu (H5N1)** [ref1](#)

**Black Lives Matter (BLM)** [ref1](#), [ref2](#), [ref3](#), [ref4](#), [ref5](#)

**Blair, Tony** [ref1](#), [ref2](#), [ref3](#), [ref4](#), [ref5](#), [ref6](#), [ref7](#)

**Brin, Sergei** [ref1](#), [ref2](#), [ref3](#), [ref4](#), [ref5](#), [ref6](#), [ref7](#)

**British Empire** [ref1](#)

**Bush, George HW** [ref1](#), [ref2](#)

**Bush, George W** [ref1](#), [ref2](#), [ref3](#), [ref4](#)

**Byrd, Robert** [ref1](#)

## **C**

### **Canada**

Global Cult [ref1](#)

hate speech [ref1](#)

internment [ref1](#)

masks [ref1](#)

old people [ref1](#)

SARS-COV-2 [ref1](#)

satellites [ref1](#)

vaccines [ref1](#)

wearable technology [ref1](#)

**Capitol Hill riot** [ref1](#), [ref2](#)

agents provocateur [ref1](#)

Antifa [ref1](#)

Black Lives Matter (BLM) [ref1](#), [ref2](#)

QAnon [ref1](#)

security precautions, lack of [ref1](#), [ref2](#), [ref3](#)

**carbon dioxide** [ref1](#), [ref2](#)

**care homes, deaths in** [ref1](#), [ref2](#)

**cashless digital money systems** [ref1](#)

**censorship** [ref1](#), [ref2](#), [ref3](#), [ref4](#), [ref5](#)

fact-checkers [ref1](#)

masks [ref1](#)

media [ref1](#), [ref2](#)

private messages [ref1](#)

social media [ref1](#), [ref2](#), [ref3](#), [ref4](#), [ref5](#), [ref6](#)

transgender persons [ref1](#)

vaccines [ref1](#), [ref2](#), [ref3](#)

Wokeness [ref1](#)

**Centers for Disease Control (CDC) (United States)** [ref1](#), [ref2](#), [ref3](#),  
[ref4](#), [ref5](#), [ref6](#), [ref7](#), [ref8](#), [ref9](#), [ref10](#), [ref11](#), [ref12](#), [ref13](#)

**centralisation** [ref1](#), [ref2](#), [ref3](#), [ref4](#), [ref5](#), [ref6](#), [ref7](#), [ref8](#)

**chakras** [ref1](#)

**change agents** [ref1](#), [ref2](#), [ref3](#)

**chemtrails** [ref1](#), [ref2](#), [ref3](#)

**chief medical officers and scientific advisers** [ref1](#), [ref2](#), [ref3](#), [ref4](#),  
[ref5](#), [ref6](#)

**children** *see also* **young people**

abuse [ref1](#), [ref2](#), [ref3](#), [ref4](#), [ref5](#), [ref6](#), [ref7](#), [ref8](#), [ref9](#), [ref10](#)

care, taken into [ref1](#), [ref2](#), [ref3](#)

education [ref1](#), [ref2](#), [ref3](#), [ref4](#)

energy [ref1](#)

family courts [ref1](#)

hand sanitisers [ref1](#)

human sacrifice [ref1](#)

lockdowns [ref1](#), [ref2](#), [ref3](#)

masks [ref1](#), [ref2](#), [ref3](#), [ref4](#), [ref5](#)

mental health [ref1](#)

old people [ref1](#)

parents, replacement of [ref1](#), [ref2](#)

Psyop (psychological operation), Covid as a [ref1](#), [ref2](#)

reframing [ref1](#)

smartphone addiction [ref1](#)

social distancing and isolation [ref1](#)  
social media [ref1](#)  
transgender persons [ref1](#), [ref2](#)  
United States [ref1](#)  
vaccines [ref1](#), [ref2](#), [ref3](#), [ref4](#), [ref5](#), [ref6](#), [ref7](#), [ref8](#), [ref9](#), [ref10](#)  
Wetiko factor [ref1](#)

## **China** [ref1](#), [ref2](#), [ref3](#), [ref4](#)

anal swab tests [ref1](#)  
**Chinese Revolution** [ref1](#), [ref2](#), [ref3](#)  
digital currency [ref1](#)  
Global Cult [ref1](#), [ref2](#), [ref3](#), [ref4](#), [ref5](#), [ref6](#), [ref7](#), [ref8](#), [ref9](#)  
guaranteed income [ref1](#)  
Imperial College [ref1](#)  
Israel [ref1](#)  
lockdown [ref1](#), [ref2](#)  
masculinity crisis [ref1](#)  
masks [ref1](#)  
media [ref1](#)  
origins of virus in China [ref1](#), [ref2](#), [ref3](#), [ref4](#), [ref5](#)  
pollution causing respiratory diseases [ref1](#)  
Sabbatians [ref1](#), [ref2](#)  
Smart Grid [ref1](#), [ref2](#)  
social credit system [ref1](#)  
testing [ref1](#), [ref2](#)  
United States [ref1](#), [ref2](#)  
vaccines [ref1](#), [ref2](#)  
Wetiko factor [ref1](#)  
wet market conspiracy [ref1](#)  
Wuhan [ref1](#), [ref2](#), [ref3](#), [ref4](#), [ref5](#), [ref6](#), [ref7](#)

## **cholesterol** [ref1](#), [ref2](#)

## **Christianity** [ref1](#), [ref2](#), [ref3](#), [ref4](#), [ref5](#)

criticism [ref1](#)  
cross, inversion of the [ref1](#)

Nag Hammadi texts [ref1](#), [ref2](#), [ref3](#)

Roman Catholic Church [ref1](#), [ref2](#)

Sabbatians [ref1](#), [ref2](#)

Satan [ref1](#), [ref2](#), [ref3](#), [ref4](#)

Wokeness [ref1](#)

**class** [ref1](#), [ref2](#)

**climate change hoax** [ref1](#), [ref2](#), [ref3](#), [ref4](#), [ref5](#)

Agenda 21/Agenda 2030 [ref1](#), [ref2](#), [ref3](#)

carbon dioxide [ref1](#), [ref2](#)

Club of Rome [ref1](#), [ref2](#), [ref3](#), [ref4](#), [ref5](#)

fear [ref1](#)

funding [ref1](#)

Global Cult [ref1](#)

green new deals [ref1](#)

green parties [ref1](#)

inversion [ref1](#)

perception, control of [ref1](#)

PICC [ref1](#)

reframing [ref1](#)

temperature, increases in [ref1](#)

United Nations [ref1](#), [ref2](#)

Wikipedia [ref1](#)

Wokeness [ref1](#), [ref2](#)

**Clinton, Bill** [ref1](#), [ref2](#), [ref3](#), [ref4](#), [ref5](#), [ref6](#)

**Clinton, Hillary** [ref1](#), [ref2](#), [ref3](#)

**the cloud** [ref1](#), [ref2](#), [ref3](#), [ref4](#), [ref5](#), [ref6](#), [ref7](#)

**Club of Rome and climate change hoax** [ref1](#), [ref2](#), [ref3](#), [ref4](#), [ref5](#)

**cognitive therapy** [ref1](#)

**Cohn, Roy** [ref1](#)

**Common Law** [ref1](#)

Admiralty Law [ref1](#)

arrests [ref1](#), [ref2](#)

contractual law, Statute Law as [ref1](#)

corporate entities, people as [ref1](#)

legalese [ref1](#)

sea, law of the [ref1](#)

Statute Law [ref1](#)

**Common Purpose leadership programme** [ref1](#), [ref2](#)

**communism** [ref1](#), [ref2](#)

**co-morbidities** [ref1](#)

**computer-generated virus,**

**Covid-19** as [ref1](#), [ref2](#), [ref3](#)

**computer models** [ref1](#), [ref2](#), [ref3](#), [ref4](#), [ref5](#)

**connections** [ref1](#), [ref2](#), [ref3](#), [ref4](#)

**consciousness** [ref1](#), [ref2](#), [ref3](#), [ref4](#)

Archons [ref1](#), [ref2](#), [ref3](#)

expanded [ref1](#), [ref2](#), [ref3](#), [ref4](#), [ref5](#), [ref6](#), [ref7](#)

experience [ref1](#)

heart [ref1](#)

infinity [ref1](#), [ref2](#)

religion [ref1](#), [ref2](#)

self-identity [ref1](#)

simulation thesis [ref1](#)

vaccines [ref1](#)

Wetiko factor [ref1](#), [ref2](#)

**conspiracy theorists** [ref1](#), [ref2](#), [ref3](#), [ref4](#), [ref5](#)

**contradictory rules** [ref1](#)

**contrails** [ref1](#)

**Corman-Drosten test** [ref1](#), [ref2](#), [ref3](#), [ref4](#)

**countermimicry** [ref1](#), [ref2](#), [ref3](#)

**Covid-19 vaccines** *see* vaccines

**Covidiots** [ref1](#), [ref2](#)

**Cowan, Tom** [ref1](#), [ref2](#), [ref3](#), [ref4](#)

**crimes against humanity** [ref1](#), [ref2](#), [ref3](#), [ref4](#), [ref5](#), [ref6](#), [ref7](#), [ref8](#)

cyber-operations [ref1](#)

cyberwarfare [ref1](#)

## **D**

DARPA (Defense Advanced Research Projects Agency) [ref1](#)

deaths

care homes [ref1](#)

certificates [ref1](#), [ref2](#), [ref3](#), [ref4](#)

mortality rate [ref1](#)

post-mortems/autopsies [ref1](#)

recording [ref1](#), [ref2](#), [ref3](#), [ref4](#), [ref5](#), [ref6](#), [ref7](#)

vaccines [ref1](#), [ref2](#), [ref3](#), [ref4](#), [ref5](#)

deceit

pyramid of deceit [ref1](#), [ref2](#)

sequence of deceit [ref1](#)

decoding [ref1](#), [ref2](#), [ref3](#)

dehumanisation [ref1](#), [ref2](#), [ref3](#)

Delphi technique [ref1](#)

democracy [ref1](#)

dependency [ref1](#), [ref2](#), [ref3](#), [ref4](#), [ref5](#)

Descartes, René [ref1](#)

DNA

numbers [ref1](#)

vaccines [ref1](#), [ref2](#), [ref3](#), [ref4](#), [ref5](#), [ref6](#), [ref7](#), [ref8](#), [ref9](#), [ref10](#)

DNR (do not resuscitate)

orders [ref1](#)

domestic abuse [ref1](#), [ref2](#)

downgrading of Covid-19 [ref1](#)

Drosten, Christian [ref1](#), [ref2](#), [ref3](#), [ref4](#), [ref5](#), [ref6](#), [ref7](#)

Duesberg, Peter [ref1](#), [ref2](#)



## **E**

**economic abuse** [ref1](#)

**Edmunds, John** [ref1](#), [ref2](#)

**education** [ref1](#), [ref2](#), [ref3](#), [ref4](#)

**electromagnetic spectrum** [ref1](#), [ref2](#)

**Enders, John** [ref1](#)

**energy**

Archons [ref1](#), [ref2](#), [ref3](#)

children and young people [ref1](#)

consciousness [ref1](#)

decoding [ref1](#)

frequencies [ref1](#), [ref2](#), [ref3](#), [ref4](#)

heart [ref1](#)

human energy field [ref1](#)

source, humans as an energy [ref1](#), [ref2](#)

vaccines [ref1](#)

viruses [ref1](#)

**ennoia** [ref1](#)

**Epstein, Jeffrey** [ref1](#), [ref2](#)

**eternal 'I'** [ref1](#), [ref2](#)

**ethylene oxide** [ref1](#)

**European Union** [ref1](#), [ref2](#), [ref3](#), [ref4](#)

**Event** [ref1](#) *and* **Bill Gates** [ref2](#)

**exosomes, Covid-19 as natural defence mechanism called** [ref1](#)

**experience** [ref1](#), [ref2](#)

**Extinction Rebellion** [ref1](#), [ref2](#)

## **F**

**Facebook**

addiction [ref1](#), 448–50

Facebook

Archons [ref1](#)

censorship [ref1](#), [ref2](#), [ref3](#)

hate speech [ref1](#)

monopoly, as [ref1](#)

private messages, censorship of [ref1](#)

Sabbatians [ref1](#)

United States election fraud [ref1](#)

vaccines [ref1](#)

Wetiko factor [ref1](#)

**fact-checkers** [ref1](#)

**Fauci, Anthony** [ref1](#), [ref2](#), [ref3](#), [ref4](#), [ref5](#), [ref6](#), [ref7](#), [ref8](#), [ref9](#), [ref10](#),  
[ref11](#), [ref12](#)

**fear** [ref1](#), [ref2](#), [ref3](#), [ref4](#)

climate change [ref1](#)

computer models [ref1](#)

conspiracy theories [ref1](#)

empty hospitals [ref1](#)

Italy [ref1](#), [ref2](#), [ref3](#)

lockdowns [ref1](#), [ref2](#), [ref3](#), [ref4](#)

masks [ref1](#), [ref2](#)

media [ref1](#), [ref2](#)

medical staff [ref1](#)

Psyop (psychological operation), Covid as a [ref1](#)

Wetiko factor [ref1](#), [ref2](#)

**female infertility** [ref1](#)

**Fermi Paradox** [ref1](#)

**Ferguson, Neil** [ref1](#), [ref2](#), [ref3](#), [ref4](#), [ref5](#), [ref6](#), [ref7](#)

**fertility, decline in** [ref1](#)

**The Field** [ref1](#), [ref2](#), [ref3](#), [ref4](#), [ref5](#), [ref6](#), [ref7](#), [ref8](#)

**finance** *see* **banking, finance and money**

**five-senses** [ref1](#), [ref2](#)

Archons [ref1](#), [ref2](#), [ref3](#)

censorship [ref1](#)  
    consciousness, expansion of [ref1](#), [ref2](#), [ref3](#), [ref4](#), [ref5](#), [ref6](#)  
    decoding [ref1](#)  
    education [ref1](#), [ref2](#)  
    the Field [ref1](#), [ref2](#)  
    God, personification of [ref1](#)  
    infinity [ref1](#), [ref2](#)  
    media [ref1](#)  
    paranormal [ref1](#)  
    perceptual programming [ref1](#), [ref2](#)  
    Phantom Self [ref1](#)  
    pneuma not nous, using [ref1](#)  
    reincarnation [ref1](#)  
    self-identity [ref1](#)  
    Wetiko factor [ref1](#), [ref2](#), [ref3](#), [ref4](#), [ref5](#), [ref6](#)  
**5G** [ref1](#), [ref2](#), [ref3](#), [ref4](#), [ref5](#), [ref6](#), [ref7](#), [ref8](#)  
**Floyd, George and protests, killing of** [ref1](#)  
**flu, re-labelling of** [ref1](#), [ref2](#), [ref3](#)  
**food and water, control of** [ref1](#), [ref2](#)  
**Freemasons** [ref1](#), [ref2](#), [ref3](#), [ref4](#), [ref5](#), [ref6](#)  
**Frei, Rosemary** [ref1](#)  
**frequencies**  
    addictions [ref1](#)  
    Archons [ref1](#), [ref2](#), [ref3](#)  
    awareness [ref1](#)  
    chanting and mantras [ref1](#)  
    consciousness [ref1](#)  
    decoding [ref1](#), [ref2](#)  
    education [ref1](#)  
    electromagnetic (EMF) frequencies [ref1](#)  
    energy [ref1](#), [ref2](#), [ref3](#), [ref4](#)  
    fear [ref1](#)

the Field [ref1](#), [ref2](#) 5G [ref3](#), [ref4](#), [ref5](#), [ref6](#), [ref7](#), [ref8](#), [ref9](#), [ref10](#)  
five-senses [ref1](#), [ref2](#)  
ghosts [ref1](#)  
Gnostics [ref1](#)  
hive-minds [ref1](#)  
human, meaning of [ref1](#)  
light [ref1](#), [ref2](#)  
love [ref1](#), [ref2](#)  
magnetism [ref1](#)  
perception [ref1](#)  
reality [ref1](#), [ref2](#), [ref3](#)  
simulation [ref1](#)  
terror [ref1](#)  
vaccines [ref1](#)  
Wetiko [ref1](#), [ref2](#), [ref3](#)

**Fuellmich, Reiner** [ref1](#), [ref2](#), [ref3](#)

**furlough/rescue payments** [ref1](#)

## **G**

**Gallo, Robert** [ref1](#), [ref2](#), [ref3](#)

**Gates, Bill**

Archons [ref1](#), [ref2](#), [ref3](#)  
climate change [ref1](#), [ref2](#), [ref3](#), [ref4](#)  
Daily Pass tracking system [ref1](#)  
Epstein [ref1](#)  
fascism [ref1](#)  
five senses [ref1](#)  
GAVI [ref1](#)  
Great Reset [ref1](#)  
GSK [ref1](#)  
Imperial College [ref1](#), [ref2](#)  
Johns Hopkins University [ref1](#), [ref2](#), [ref3](#)

lockdowns [ref1](#), [ref2](#)

masks [ref1](#)

Nuremberg trial, proposal for [ref1](#), [ref2](#)

Rockefellers [ref1](#), [ref2](#)

social distancing and isolation [ref1](#)

Sun, dimming the [ref1](#)

synthetic meat [ref1](#), [ref2](#)

vaccines [ref1](#), [ref2](#), [ref3](#), [ref4](#), [ref5](#), [ref6](#), [ref7](#)

Wellcome Trust [ref1](#)

Wetiko factor [ref1](#), [ref2](#), [ref3](#)

WHO [ref1](#), [ref2](#), [ref3](#), [ref4](#), [ref5](#), [ref6](#), [ref7](#), [ref8](#), [ref9](#), [ref10](#)

Wokeness [ref1](#)

World Economic Forum [ref1](#), [ref2](#), [ref3](#), [ref4](#)

**Gates, Melinda** [ref1](#), [ref2](#), [ref3](#)

**GAVI vaccine alliance** [ref1](#)

**genetics, manipulation of** [ref1](#), [ref2](#), [ref3](#)

**Germany** [ref1](#), [ref2](#), [ref3](#), [ref4](#), [ref5](#), [ref6](#) *see also* **Nazi Germany**

**Global Cult** [ref1](#), [ref2](#), [ref3](#), [ref4](#), [ref5](#)

anti-human, why Global Cult is [ref1](#)

Black Lives Matter (BLM) [ref1](#), [ref2](#), [ref3](#), [ref4](#)

China [ref1](#), [ref2](#), [ref3](#), [ref4](#), [ref5](#), [ref6](#), [ref7](#), [ref8](#), [ref9](#)

climate change hoax [ref1](#)

contradictory rules [ref1](#)

Covid-19 [ref1](#), [ref2](#), [ref3](#)

fascism [ref1](#)

geographical origins [ref1](#)

immigration [ref1](#)

Internet [ref1](#)

mainstream media [ref1](#), [ref2](#)

masks [ref1](#), [ref2](#)

monarchy [ref1](#)

non-human dimension [ref1](#)

perception [ref1](#)  
political parties [ref1](#), [ref2](#)  
pyramidal hierarchy [ref1](#), [ref2](#), [ref3](#)  
reframing [ref1](#)  
Sabbantian-Frankism [ref1](#), [ref2](#)  
science, manipulation of [ref1](#)  
spider and the web [ref1](#)  
transgender persons [ref1](#)  
vaccines [ref1](#)  
who controls the Cult [ref1](#)  
Wokeness [ref1](#), [ref2](#), [ref3](#), [ref4](#)

**globalisation** [ref1](#), [ref2](#)

**Gnostics** [ref1](#), [ref2](#), [ref3](#), [ref4](#), [ref5](#)

**Google** [ref1](#), [ref2](#), [ref3](#), [ref4](#)

**government**

behavioural scientists and psychologists, advice from [ref1](#), [ref2](#)  
definition [ref1](#)

Joint Biosecurity Centre (JBC) [ref1](#)

people, abusive relationship with [ref1](#)

**Great Reset** [ref1](#), [ref2](#), [ref3](#), [ref4](#), [ref5](#), [ref6](#)

fascism [ref1](#), [ref2](#), [ref3](#)

financial system [ref1](#)

Human 2.0 [ref1](#)

water and food, control of [ref1](#)

**green parties** [ref1](#)

**Griesz-Brisson, Margarite** [ref1](#)

**guaranteed income** [ref1](#), [ref2](#), [ref3](#)

**H**

**Hancock, Matt** [ref1](#), [ref2](#), [ref3](#), [ref4](#), [ref5](#)

**hand sanitisers** [ref1](#)

**heart** [ref1](#), [ref2](#)

**hive-minds/groupthink** [ref1](#), [ref2](#), [ref3](#)

**holographs** [ref1](#), [ref2](#), [ref3](#), [ref4](#)

**hospitals, empty** [ref1](#)

**human, meaning of** [ref1](#)

**Human 2.0** [ref1](#)

addiction to technology [ref1](#)

artificial intelligence (AI) [ref1](#), [ref2](#)

elimination of Human 1.0 [ref1](#)

fertility, decline in [ref1](#)

Great Reset [ref1](#)

implantables [ref1](#)

money [ref1](#)

mRNA [ref1](#)

nanotechnology [ref1](#)

parents, replacement of [ref1](#), [ref2](#)

Smart Grid, connection to [ref1](#), [ref2](#)

synthetic biology [ref1](#), [ref2](#), [ref3](#), [ref4](#)

testosterone levels, decrease in [ref1](#)

transgender = transhumanism [ref1](#), [ref2](#), [ref3](#)

vaccines [ref1](#), [ref2](#), [ref3](#), [ref4](#)

**human sacrifice** [ref1](#), [ref2](#), [ref3](#)

**Hunger Games Society** [ref1](#), [ref2](#), [ref3](#), [ref4](#), [ref5](#), [ref6](#), [ref7](#)

**Huxley, Aldous** [ref1](#), [ref2](#), [ref3](#)

**I**

**identity politics** [ref1](#), [ref2](#), [ref3](#)

**Illuminati** [ref1](#), [ref2](#)

**illusory physical reality** [ref1](#)

**immigration** [ref1](#), [ref2](#), [ref3](#), [ref4](#)

**Imperial College** [ref1](#), [ref2](#), [ref3](#), [ref4](#), [ref5](#), [ref6](#)

**implantables** [ref1](#), [ref2](#)

**incomes, destruction of** [ref1](#), [ref2](#)

**Infinite Awareness** [ref1](#), [ref2](#), [ref3](#), [ref4](#)

**Internet** [ref1](#), [ref2](#) *see also* social media

artificial intelligence (AI) [ref1](#)

independent journalism, lack of [ref1](#)

Internet of Bodies (IoB) [ref1](#)

**Internet of Everything (IoE)** [ref1](#), [ref2](#)

**Internet of Things (IoT)** [ref1](#), [ref2](#)

**lockdowns** [ref1](#)

Psyop (psychological operation), Covid as a [ref1](#)  
trolls [ref1](#)

**intersectionality** [ref1](#)

**inversion**

Archons [ref1](#), [ref2](#), [ref3](#)

climate change hoax [ref1](#)

energy [ref1](#)

Judaism [ref1](#), [ref2](#), [ref3](#)

symbolism [ref1](#)

Wetiko factor [ref1](#)

Wokeness [ref1](#), [ref2](#), [ref3](#)

**Islam**

Archons [ref1](#)

crypto-Jews [ref1](#)

Islamic State [ref1](#), [ref2](#)

Jinn and Djinn [ref1](#), [ref2](#), [ref3](#)

Ottoman Empire [ref1](#)

Wahhabism [ref1](#)

**isolation** *see* **social distancing** *and* **isolation**

**Israel**

China [ref1](#)

Cyber Intelligence Unit Beersheba complex [ref1](#)

expansion of illegal settlements [ref1](#)



formation [ref1](#)  
Global Cult [ref1](#)  
Judaism [ref1](#), [ref2](#), [ref3](#), [ref4](#), [ref5](#)  
medical experiments, consent for [ref1](#)  
Mossad [ref1](#), [ref2](#), [ref3](#), [ref4](#)  
Palestine-Israel conflict [ref1](#), [ref2](#), [ref3](#)  
parents, replacement of [ref1](#)  
Sabbatians [ref1](#), [ref2](#), [ref3](#), [ref4](#), [ref5](#)  
September 11, 2001, terrorist attacks on United States [ref1](#)  
Silicon Valley [ref1](#)  
Smart Grid [ref1](#), [ref2](#)  
United States [ref1](#), [ref2](#)  
vaccines [ref1](#)  
Wetiko factor [ref1](#)

## **Italy**

fear [ref1](#), [ref2](#), [ref3](#)  
Lombardy [ref1](#), [ref2](#), [ref3](#)  
vaccines [ref1](#)

## **J**

**Johns Hopkins University** [ref1](#), [ref2](#), [ref3](#), [ref4](#), [ref5](#), [ref6](#), [ref7](#)  
**Johnson, Boris** [ref1](#), [ref2](#), [ref3](#), [ref4](#), [ref5](#), [ref6](#), [ref7](#), [ref8](#)  
**Joint Biosecurity Centre (JBC)** [ref1](#)

## **Judaism**

anti-Semitism [ref1](#), [ref2](#), [ref3](#)  
Archons [ref1](#), [ref2](#)  
crypto-Jews [ref1](#)  
inversion [ref1](#), [ref2](#), [ref3](#)  
Israel [ref1](#), [ref2](#), [ref3](#), [ref4](#), [ref5](#)  
Labour Party [ref1](#)  
Nazi Germany [ref1](#), [ref2](#), [ref3](#), [ref4](#)  
Sabbatians [ref1](#), [ref2](#), [ref3](#), [ref4](#), [ref5](#)

Silicon Valley [ref1](#)  
Torah [ref1](#)  
United States [ref1](#), [ref2](#)  
Zionists [ref1](#), [ref2](#), [ref3](#)

## **K**

Kaufman, Andrew [ref1](#), [ref2](#), [ref3](#), [ref4](#)  
knowledge [ref1](#), [ref2](#), [ref3](#), [ref4](#), [ref5](#), [ref6](#)  
Koch's postulates [ref1](#)  
Kurzweil, Ray [ref1](#), [ref2](#), [ref3](#), [ref4](#), [ref5](#), [ref6](#), [ref7](#)  
Kushner, Jared [ref1](#), [ref2](#)

## **L**

Labour Party [ref1](#), [ref2](#)  
Lanka, Stefan [ref1](#), [ref2](#)  
Lateral Flow Device (LFD) [ref1](#)  
Levy, Paul [ref1](#), [ref2](#), [ref3](#)  
Life Program [ref1](#)  
lockdowns [ref1](#), [ref2](#), [ref3](#)  
    amplification tampering [ref1](#)  
    Archons [ref1](#)  
    Behavioural Insights Team [ref1](#)  
    Black Lives Matter (BLM) [ref1](#)  
    care homes, deaths in [ref1](#)  
    children  
abuse [ref1](#), [ref2](#)  
mental health [ref1](#)  
    China [ref1](#), [ref2](#)  
    computer models [ref1](#)  
    consequences [ref1](#), [ref2](#)  
    dependency [ref1](#), [ref2](#), [ref3](#)

domestic abuse [ref1](#)  
fall in cases [ref1](#)  
fear [ref1](#), [ref2](#), [ref3](#), [ref4](#)  
guaranteed income [ref1](#)  
Hunger Games Society [ref1](#), [ref2](#), [ref3](#)  
interaction, destroying [ref1](#)  
Internet [ref1](#), [ref2](#)  
overdoses [ref1](#)  
perception [ref1](#)  
police-military state [ref1](#), [ref2](#)  
protests [ref1](#), [ref2](#), [ref3](#), [ref4](#), [ref5](#)  
psychopathic personality [ref1](#), [ref2](#), [ref3](#)  
reporting/snitching, encouragement of [ref1](#), [ref2](#)  
testing [ref1](#)  
vaccines [ref1](#)  
Wetiko factor [ref1](#)  
WHO [ref1](#)  
**love** [ref1](#), [ref2](#), [ref3](#)  
**Lucifer** [ref1](#), [ref2](#), [ref3](#)

## **M**

**Madej, Carrie** [ref1](#), [ref2](#)  
**Magufuli, John** [ref1](#), [ref2](#)  
**mainstream media** [ref1](#)  
BBC [ref1](#), [ref2](#), [ref3](#), [ref4](#), [ref5](#), [ref6](#), [ref7](#), [ref8](#)  
censorship [ref1](#), [ref2](#)  
China [ref1](#)  
climate change hoax [ref1](#)  
fear [ref1](#), [ref2](#)  
Global Cult [ref1](#), [ref2](#)  
independent journalism, lack of [ref1](#)  
Ofcom [ref1](#), [ref2](#), [ref3](#)

perception [ref1](#), [ref2](#)

Psyop (psychological operation), Covid as a [ref1](#)

Sabbatians [ref1](#), [ref2](#)

social disapproval [ref1](#)

social distancing and isolation [ref1](#)

United States [ref1](#), [ref2](#)

vaccines [ref1](#), [ref2](#), [ref3](#), [ref4](#), [ref5](#)

**Mao Zedong** [ref1](#), [ref2](#), [ref3](#)

**Marx and Marxism** [ref1](#), [ref2](#), [ref3](#), [ref4](#), [ref5](#), [ref6](#)

**masculinity** [ref1](#)

**masks/face coverings** [ref1](#), [ref2](#), [ref3](#)

    censorship [ref1](#)

    children [ref1](#), [ref2](#), [ref3](#), [ref4](#), [ref5](#)

    China, made in [ref1](#)

    dehumanisation [ref1](#), [ref2](#), [ref3](#)

    fear [ref1](#), [ref2](#)

    flu [ref1](#)

    health professionals [ref1](#), [ref2](#), [ref3](#), [ref4](#)

    isolation [ref1](#)

    laughter [ref1](#)

**mass non-cooperation** [ref1](#)

**microplastics, risk of** [ref1](#)

**mind control** [ref1](#)

**multiple masks** [ref1](#)

oxygen deficiency [ref1](#), [ref2](#), [ref3](#)

police [ref1](#), [ref2](#), [ref3](#), [ref4](#), [ref5](#)

pollution, as cause of plastic [ref1](#)

Psyop (psychological operation), Covid as a [ref1](#)

reframing [ref1](#), [ref2](#)

risk assessments, lack of [ref1](#), [ref2](#)

self-respect [ref1](#)

surgeons [ref1](#)

United States [ref1](#)  
vaccines [ref1](#), [ref2](#), [ref3](#), [ref4](#), [ref5](#)  
Wetiko factor [ref1](#)  
'worms' [ref1](#)  
*The Matrix* movies [ref1](#), [ref2](#), [ref3](#)  
measles [ref1](#), [ref2](#)  
media see mainstream media  
Medicines and Healthcare products Regulatory Agency (MHRA)  
    [ref1](#), [ref2](#), [ref3](#), [ref4](#)  
Mesopotamia [ref1](#)  
messaging [ref1](#)  
military-police state [ref1](#), [ref2](#), [ref3](#)  
mind control [ref1](#), [ref2](#), [ref3](#), [ref4](#), [ref5](#), [ref6](#) *see also* MKUltra  
MKUltra [ref1](#), [ref2](#), [ref3](#)  
monarchy [ref1](#)  
money *see* banking, finance and money  
Montagnier, Luc [ref1](#), [ref2](#), [ref3](#)  
Mooney, Bel [ref1](#)  
Morgellons disease [ref1](#), [ref2](#)  
mortality rate [ref1](#)  
Mullis, Kary [ref1](#), [ref2](#), [ref3](#)  
Musk, Elon [ref1](#)

## **N**

Nag Hammadi texts [ref1](#), [ref2](#), [ref3](#)  
nanotechnology [ref1](#), [ref2](#), [ref3](#)  
narcissism [ref1](#)  
Nazi Germany [ref1](#), [ref2](#), [ref3](#), [ref4](#), [ref5](#), [ref6](#), [ref7](#), [ref8](#)  
near-death experiences [ref1](#), [ref2](#)  
Neocons [ref1](#), [ref2](#), [ref3](#)

**Neuro-Linguistic Programming (NLP) and the Delphi technique**  
[ref1](#)

**NHS (National Health Service)**

amplification cycles [ref1](#)

Common Purpose [ref1](#), [ref2](#)

mind control [ref1](#)

**NHS England** [ref1](#)

saving the NHS [ref1](#), [ref2](#)

vaccines [ref1](#), [ref2](#), [ref3](#), [ref4](#), [ref5](#)

whistle-blowers [ref1](#), [ref2](#), [ref3](#)

**No-Problem-Reaction-Solution** [ref1](#), [ref2](#), [ref3](#), [ref4](#)

**non-human dimension of Global Cult** [ref1](#)

**nous** [ref1](#)

**numbers, reality as** [ref1](#)

**Nuremberg Codes** [ref1](#), [ref2](#), [ref3](#)

**Nuremberg-like tribunal, proposal for** [ref1](#), [ref2](#), [ref3](#), [ref4](#), [ref5](#),  
[ref6](#), [ref7](#), [ref8](#), [ref9](#), [ref10](#), [ref11](#), [ref12](#)

## **O**

**Obama, Barack** [ref1](#), [ref2](#), [ref3](#), [ref4](#), [ref5](#), [ref6](#), [ref7](#), [ref8](#), [ref9](#), [ref10](#)

**O'Brien, Cathy** [ref1](#), [ref2](#), [ref3](#), [ref4](#)

**Ochel, Evita** [ref1](#)

**Ofcom** [ref1](#), [ref2](#), [ref3](#)

**old people** [ref1](#), [ref2](#), [ref3](#), [ref4](#), [ref5](#)

**Oneness** [ref1](#), [ref2](#), [ref3](#)

**Open Society Foundations (Soros)** [ref1](#), [ref2](#), [ref3](#)

**oxygen** 406, 528–34

## **P**

**paedophilia** [ref1](#), [ref2](#)

**Page, Larry** [ref1](#), [ref2](#), [ref3](#), [ref4](#), [ref5](#), [ref6](#), [ref7](#)

**Palestine-Israel conflict** [ref1](#), [ref2](#), [ref3](#)

**pandemic, definition of** [ref1](#)

**pandemic and health crisis scenarios/simulations** [ref1](#), [ref2](#), [ref3](#),  
[ref4](#)

**paranormal** [ref1](#)

**PCR tests** [ref1](#), [ref2](#), [ref3](#), [ref4](#), [ref5](#), [ref6](#), [ref7](#), [ref8](#)

**Pearl Harbor attacks, prior knowledge of** [ref1](#)

**Pelosi, Nancy** [ref1](#), [ref2](#), [ref3](#)

**perception** [ref1](#), [ref2](#), [ref3](#), [ref4](#)

climate change hoax [ref1](#)

control [ref1](#), [ref2](#), [ref3](#)

decoding [ref1](#), [ref2](#)

enslavement [ref1](#)

externally-delivered perceptions [ref1](#)

five senses [ref1](#)

human labels [ref1](#)

media [ref1](#), [ref2](#)

political parties [ref1](#), [ref2](#)

Psyop (psychological operation), Covid as a [ref1](#)

sale of perception [ref1](#)

self-identity [ref1](#), [ref2](#)

Wokeness [ref1](#)

**Phantom Self** [ref1](#), [ref2](#), [ref3](#)

**pharmaceutical industry** *see* **Big Pharma**

**phthalates** [ref1](#)

**Plato's Allegory of the Cave** [ref1](#), [ref2](#)

**pneuma** [ref1](#)

**police**

Black Lives Matter (BLM) [ref1](#)

brutality [ref1](#)

citizen's arrests [ref1](#), [ref2](#)

common law arrests [ref1](#), [ref2](#)

Common Purpose [ref1](#)  
defunding [ref1](#)  
lockdowns [ref1](#), [ref2](#)  
masks [ref1](#), [ref2](#), [ref3](#), [ref4](#)  
police-military state [ref1](#), [ref2](#), [ref3](#)  
psychopathic personality [ref1](#), [ref2](#), [ref3](#), [ref4](#)  
reframing [ref1](#)  
United States [ref1](#), [ref2](#), [ref3](#), [ref4](#)  
Wokeness [ref1](#)

**polio** [ref1](#)

**political correctness** [ref1](#), [ref2](#), [ref3](#), [ref4](#)

**political parties** [ref1](#), [ref2](#), [ref3](#), [ref4](#)

**political puppets** [ref1](#)

**pollution** [ref1](#), [ref2](#), [ref3](#)

**post-mortems/autopsies** [ref1](#)

**Postage Stamp Consensus** [ref1](#), [ref2](#)

**pre-emptive programming** [ref1](#)

**Problem-Reaction-Solution** [ref1](#), [ref2](#), [ref3](#), [ref4](#), [ref5](#), [ref6](#), [ref7](#), [ref8](#)

**Project for the New American Century** [ref1](#), [ref2](#), [ref3](#), [ref4](#)

**psychopathic personality** [ref1](#)

Archons [ref1](#)

heart energy [ref1](#)

lockdowns [ref1](#), [ref2](#), [ref3](#)

police [ref1](#), [ref2](#), [ref3](#), [ref4](#)

recruitment [ref1](#), [ref2](#)

vaccines [ref1](#)

wealth [ref1](#)

Wetiko [ref1](#), [ref2](#)

**Psyop (psychological operation), Covid as a** [ref1](#), [ref2](#), [ref3](#), [ref4](#),  
[ref5](#)

**Pushbackers** [ref1](#), [ref2](#), [ref3](#), [ref4](#)

**pyramid structure** [ref1](#), [ref2](#), [ref3](#), [ref4](#)



## Q

**QAnon Psyop** [ref1](#), [ref2](#), [ref3](#)

## R

**racism** *see also* **Black Lives**

Matter (BLM)

anti-racism industry [ref1](#)

class [ref1](#)

critical race theory [ref1](#)

culture [ref1](#)

intersectionality [ref1](#)

reverse racism [ref1](#)

white privilege [ref1](#), [ref2](#)

white supremacy [ref1](#), [ref2](#), [ref3](#), [ref4](#), [ref5](#)

Wokeness [ref1](#), [ref2](#), [ref3](#)

**radiation** [ref1](#), [ref2](#)

**randomness, illusion of** [ref1](#), [ref2](#), [ref3](#)

**reality** [ref1](#), [ref2](#), [ref3](#)

**reframing** [ref1](#), [ref2](#)

change agents [ref1](#), [ref2](#)

children [ref1](#)

climate change [ref1](#)

Common Purpose leadership programme [ref1](#), [ref2](#)

contradictory rules [ref1](#)

enforcers [ref1](#)

masks [ref1](#), [ref2](#)

NLP and the Delphi technique [ref1](#)

police [ref1](#)

Wetiko factor [ref1](#)

Wokeness [ref1](#), [ref2](#)

**religion** *see also* particular religions

alien invasions [ref1](#)

Archons [ref1](#), [ref2](#)  
consciousness [ref1](#), [ref2](#)  
control, system of [ref1](#), [ref2](#), [ref3](#)  
criticism, prohibition on [ref1](#)  
five senses [ref1](#)  
good and evil, war between [ref1](#)  
hidden non-human forces [ref1](#), [ref2](#)  
Sabbatians [ref1](#)  
save me syndrome [ref1](#)  
Wetiko [ref1](#)  
Wokeness [ref1](#)

**repetition and mind control** [ref1](#), [ref2](#), [ref3](#)  
**reporting/snitching, encouragement of** [ref1](#), [ref2](#)  
**Reptilians/Grey entities** [ref1](#)  
**rewiring the mind** [ref1](#)  
**Rivers, Thomas Milton** [ref1](#), [ref2](#)  
**Rockefeller family** [ref1](#), [ref2](#), [ref3](#), [ref4](#), [ref5](#), [ref6](#), [ref7](#), [ref8](#), [ref9](#)  
**Rockefeller Foundation documents** [ref1](#), [ref2](#), [ref3](#), [ref4](#)  
**Roman Empire** [ref1](#)  
**Rothschild family** [ref1](#), [ref2](#), [ref3](#), [ref4](#), [ref5](#), [ref6](#), [ref7](#), [ref8](#), [ref9](#)  
**RT-PCR tests** [ref1](#), [ref2](#), [ref3](#), [ref4](#), [ref5](#), [ref6](#), [ref7](#), [ref8](#)  
**Russia**  
    collusion inquiry in US [ref1](#)  
**Russian Revolution** [ref1](#), [ref2](#)  
Sabbatians [ref1](#)

## **S**

**Sabbatian-Frankism** [ref1](#), [ref2](#)  
    anti-Semitism [ref1](#), [ref2](#)  
    banking and finance [ref1](#), [ref2](#), [ref3](#)  
    China [ref1](#), [ref2](#)  
    Israel [ref1](#), [ref2](#), [ref3](#), [ref4](#), [ref5](#)

Judaism [ref1](#), [ref2](#), [ref3](#), [ref4](#), [ref5](#)  
Lucifer [ref1](#)  
media [ref1](#), [ref2](#)  
Nazis [ref1](#), [ref2](#)  
QAnon [ref1](#)  
Rothschilds [ref1](#), [ref2](#), [ref3](#), [ref4](#), [ref5](#), [ref6](#)  
Russia [ref1](#)  
Saudi Arabia [ref1](#)  
Silicon Valley [ref1](#)  
Sumer [ref1](#)  
United States [ref1](#), [ref2](#), [ref3](#)  
Wetiko factor [ref1](#)  
Wokeness [ref1](#), [ref2](#), [ref3](#)  
**SAGE (Scientific Advisory Group for Emergencies)** [ref1](#), [ref2](#), [ref3](#),  
[ref4](#)  
**SARS-1** [ref1](#)  
**SARs-CoV-2** [ref1](#), [ref2](#), [ref3](#), [ref4](#), [ref5](#), [ref6](#), [ref7](#), [ref8](#)  
**Satan/Satanism** [ref1](#), [ref2](#), [ref3](#), [ref4](#), [ref5](#), [ref6](#), [ref7](#)  
**satellites in low-orbit** [ref1](#)  
**Saudi Arabia** [ref1](#)  
**Save Me Syndrome** [ref1](#)  
**scapegoating** [ref1](#)  
**Schwab, Klaus** [ref1](#), [ref2](#), [ref3](#), [ref4](#), [ref5](#), [ref6](#), [ref7](#), [ref8](#), [ref9](#), [ref10](#),  
[ref11](#), [ref12](#)  
**science, manipulation of** [ref1](#)  
**self-identity** [ref1](#), [ref2](#), [ref3](#), [ref4](#)  
**self-respect, attacks on** [ref1](#)  
**September 11, 2001, terrorist attacks on United States** [ref1](#), [ref2](#),  
[ref3](#), [ref4](#)  
**77th Brigade of UK military** [ref1](#), [ref2](#), [ref3](#)  
**Silicon Valley/tech giants** [ref1](#), [ref2](#), [ref3](#), [ref4](#), [ref5](#), [ref6](#) *see also*  
**Facebook**

Israel [ref1](#)

Sabbatians [ref1](#)

technocracy [ref1](#)

Wetiko factor [ref1](#)

Wokeness [ref1](#)

**simulation hypothesis** [ref1](#), [ref2](#), [ref3](#), [ref4](#), [ref5](#)

**Smart Grid** [ref1](#), [ref2](#), [ref3](#)

artificial intelligence (AI) [ref1](#)

China [ref1](#), [ref2](#)

control centres [ref1](#)

the Field [ref1](#)

Great Reset [ref1](#)

Human 2.0 [ref1](#), [ref2](#)

Israel [ref1](#), [ref2](#)

vaccines [ref1](#)

Wetiko factor [ref1](#)

**social disapproval** [ref1](#)

**social distancing and isolation** [ref1](#), [ref2](#), [ref3](#)

abusive relationships [ref1](#), [ref2](#)

children [ref1](#)

flats and apartments [ref1](#)

heart issues [ref1](#)

hugs [ref1](#)

Internet [ref1](#)

masks [ref1](#)

media [ref1](#)

older people [ref1](#), [ref2](#)

one-metre (three feet) rule [ref1](#)

rewiring the mind [ref1](#)

**simulation, universe as a** [ref1](#)

**SPI-B** [ref1](#)

substance abuse [ref1](#)

suicide and self-harm [ref1](#), [ref2](#), [ref3](#), [ref4](#), [ref5](#)

technology [ref1](#)

torture, as [ref1](#), [ref2](#)

two-metre (six feet) rule [ref1](#)

women [ref1](#)

**social justice** [ref1](#), [ref2](#), [ref3](#), [ref4](#)

**social media** *see also* **Facebook bans on alternative views** [ref1](#)

  censorship [ref1](#), [ref2](#), [ref3](#), [ref4](#), [ref5](#), [ref6](#)

  children [ref1](#)

  emotion [ref1](#)

  perception [ref1](#)

  private messages [ref1](#)

  Twitter [ref1](#), [ref2](#), [ref3](#), [ref4](#), [ref5](#), [ref6](#), [ref7](#)

  Wetiko factor [ref1](#)

  YouTube [ref1](#), [ref2](#), [ref3](#), [ref4](#), [ref5](#)

**Soros, George** [ref1](#), [ref2](#), [ref3](#), [ref4](#), [ref5](#), [ref6](#)

**Spain** [ref1](#)

**SPI-B (Scientific Pandemic Insights Group on Behaviours)** [ref1](#),  
[ref2](#), [ref3](#), [ref4](#)

**spider and the web** [ref1](#), [ref2](#), [ref3](#), [ref4](#)

**Starmer, Keir** [ref1](#)

**Statute Law** [ref1](#)

**Steiner, Rudolf** [ref1](#), [ref2](#), [ref3](#)

**Stockholm syndrome** [ref1](#)

**streptomycin** [ref1](#)

**suicide and self-harm** [ref1](#), [ref2](#), [ref3](#), [ref4](#), [ref5](#)

**Sumer** [ref1](#), [ref2](#)

**Sunstein, Cass** [ref1](#), [ref2](#), [ref3](#)

**swine flu (H1N1)** [ref1](#), [ref2](#), [ref3](#)

**synchronicity** [ref1](#)

**synthetic biology** [ref1](#), [ref2](#), [ref3](#), [ref4](#)

**synthetic meat** [ref1](#), [ref2](#)

## **T**

**technology** *see also* **artificial intelligence (AI); Internet;**

social media addiction [ref1](#), [ref2](#), [ref3](#), [ref4](#)

Archons [ref1](#), [ref2](#)

the cloud [ref1](#), [ref2](#), [ref3](#), [ref4](#), [ref5](#), [ref6](#), [ref7](#)

cyber-operations [ref1](#)

cyberwarfare [ref1](#)

radiation [ref1](#), [ref2](#)

social distancing and isolation [ref1](#)

technocracy [ref1](#)

**Tedros Adhanom Ghebreyesus** [ref1](#), [ref2](#), [ref3](#), [ref4](#), [ref5](#), [ref6](#), [ref7](#),  
[ref8](#), [ref9](#), [ref10](#), [ref11](#), [ref12](#), [ref13](#)

telepathy [ref1](#)

**Tenpenny, Sherri** [ref1](#)

**Tesla, Nikola** [ref1](#)

**testosterone levels, decrease in** [ref1](#)

**testing for Covid-19** [ref1](#), [ref2](#)

anal swab tests [ref1](#)

cancer [ref1](#)

China [ref1](#), [ref2](#), [ref3](#)

Corman-Drosten test [ref1](#), [ref2](#), [ref3](#), [ref4](#)

death certificates [ref1](#), [ref2](#)

fraudulent testing [ref1](#)

genetic material, amplification of [ref1](#)

Lateral Flow Device (LFD) [ref1](#)

PCR tests [ref1](#), [ref2](#), [ref3](#), [ref4](#), [ref5](#), [ref6](#), [ref7](#), [ref8](#)

vaccines [ref1](#), [ref2](#), [ref3](#)

**Thunberg, Greta** [ref1](#), [ref2](#), [ref3](#)

**Totalitarian Tiptoe** [ref1](#), [ref2](#), [ref3](#), [ref4](#)

**transgender persons**

activism [ref1](#)

artificial wombs [ref1](#)

[censorship ref1](#)  
[child abuse ref1, ref2](#)  
[Human 2.0 ref1, ref2, ref3](#)  
[Wokeness ref1, ref2, ref3, ref4, ref5](#)  
[women, deletion of rights and status of ref1, ref2](#)  
[young persons ref1](#)

**travel restrictions** [ref1](#)

**Trudeau, Justin** [ref1, ref2, ref3](#)

**Trump, Donald** [ref1, ref2, ref3, ref4, ref5, ref6, ref7, ref8, ref9, ref10, ref11](#)

**Twitter** [ref1, ref2, ref3, ref4, ref5, ref6, ref7](#)

## **U**

**UKColumn** [ref1, ref2](#)

**United Nations (UN)** [ref1, ref2, ref3, ref4, ref5](#) *see also* **Agenda 21/Agenda 2030 (UN)**

**United States** [ref1, ref2](#)

[American Revolution ref1](#)

[borders ref1, ref2](#)

[Capitol Hill riot ref1, ref2](#)

[children ref1](#)

[China ref1, ref2](#)

[CIA ref1, ref2](#)

[Daily Pass tracking system ref1](#)

[demographics by immigration, changes in ref1](#)

[Democrats ref1, ref2, ref3, ref4, ref5, ref6, ref7](#)

[election fraud ref1](#)

[far-right domestic terrorists, pushbackers as ref1](#)

[Federal Reserve ref1](#)

[flu/respiratory diseases statistics ref1](#)

[Global Cult ref1, ref2](#)

[hand sanitisers, FDA warnings on ref1](#)

immigration, effects of illegal [ref1](#)  
impeachment [ref1](#)  
Israel [ref1](#), [ref2](#)  
Judaism [ref1](#), [ref2](#), [ref3](#)  
lockdown [ref1](#)  
masks [ref1](#)  
mass media [ref1](#), [ref2](#)  
nursing homes [ref1](#)  
Pentagon [ref1](#), [ref2](#), [ref3](#), [ref4](#)  
police [ref1](#), [ref2](#), [ref3](#), [ref4](#)  
pushbackers [ref1](#)  
Republicans [ref1](#), [ref2](#)  
borders [ref1](#), [ref2](#)  
Democrats [ref1](#), [ref2](#), [ref3](#), [ref4](#), [ref5](#)  
Russia, inquiry into collusion with [ref1](#)  
Sabbatians [ref1](#), [ref2](#), [ref3](#)  
September 11, 2001, terrorist attacks [ref1](#), [ref2](#), [ref3](#), [ref4](#)  
UFO sightings, release of information on [ref1](#)  
vaccines [ref1](#)  
white supremacy [ref1](#), [ref2](#), [ref3](#), [ref4](#)  
Woke Democrats [ref1](#), [ref2](#)

## **V**

vaccines [ref1](#), [ref2](#), [ref3](#)  
adverse reactions [ref1](#), [ref2](#), [ref3](#), [ref4](#), [ref5](#)  
Africa [ref1](#)  
anaphylactic shock [ref1](#), [ref2](#), [ref3](#), [ref4](#)  
animals [ref1](#), [ref2](#)  
anti-vax movement [ref1](#), [ref2](#), [ref3](#), [ref4](#), [ref5](#)  
AstraZeneca/Oxford [ref1](#), [ref2](#), [ref3](#), [ref4](#)  
autoimmune diseases, rise in [ref1](#), [ref2](#)  
Big Pharma [ref1](#), [ref2](#), [ref3](#), [ref4](#), [ref5](#), [ref6](#), [ref7](#), [ref8](#)



bioweapon, as real [ref1](#), [ref2](#)  
black and ethnic minority communities [ref1](#)  
blood clots [ref1](#), [ref2](#)  
Brain Computer Interface (BCI) [ref1](#)  
care homes, deaths in [ref1](#)  
censorship [ref1](#), [ref2](#), [ref3](#)  
chief medical officers and scientific advisers, financial interests of  
[ref1](#), [ref2](#)  
children [ref1](#), [ref2](#), [ref3](#), [ref4](#), [ref5](#), [ref6](#), [ref7](#), [ref8](#), [ref9](#), [ref10](#)  
China [ref1](#), [ref2](#)  
clinical trials [ref1](#), [ref2](#), [ref3](#), [ref4](#), [ref5](#), [ref6](#)  
compensation [ref1](#)  
compulsory vaccinations [ref1](#), [ref2](#), [ref3](#)  
computer programs [ref1](#)  
consciousness [ref1](#)  
cover-ups [ref1](#)  
creation before Covid [ref1](#)  
cytokine storm [ref1](#)  
deaths and illnesses caused by vaccines [ref1](#), [ref2](#), [ref3](#), [ref4](#), [ref5](#)  
definition [ref1](#)  
developing countries [ref1](#)  
digital tattoos [ref1](#)  
DNA-manipulation [ref1](#), [ref2](#), [ref3](#), [ref4](#), [ref5](#), [ref6](#), [ref7](#), [ref8](#), [ref9](#),  
[ref10](#)  
emergency approval [ref1](#), [ref2](#), [ref3](#), [ref4](#), [ref5](#)  
female infertility [ref1](#)  
funding [ref1](#)  
genetic suicide [ref1](#)  
Global Cult [ref1](#)  
heart chakras [ref1](#)  
hesitancy [ref1](#)  
Human 2.0 [ref1](#), [ref2](#), [ref3](#), [ref4](#)  
immunity from prosecution [ref1](#), [ref2](#), [ref3](#)

implantable technology [ref1](#)  
Israel [ref1](#)  
Johnson & Johnson [ref1](#), [ref2](#), [ref3](#), [ref4](#)  
lockdowns [ref1](#)  
long-term effects [ref1](#)  
mainstream media [ref1](#), [ref2](#), [ref3](#), [ref4](#), [ref5](#)  
masks [ref1](#), [ref2](#), [ref3](#), [ref4](#), [ref5](#)  
Medicines and Healthcare products Regulatory Agency (MHRA)  
[ref1](#), [ref2](#)  
messaging [ref1](#)  
Moderna [ref1](#), [ref2](#), [ref3](#), [ref4](#), [ref5](#), [ref6](#)  
mRNA vaccines [ref1](#), [ref2](#), [ref3](#), [ref4](#), [ref5](#), [ref6](#), [ref7](#), [ref8](#), [ref9](#)  
nanotechnology [ref1](#), [ref2](#)  
NHS [ref1](#), [ref2](#), [ref3](#), [ref4](#), [ref5](#)  
older people [ref1](#), [ref2](#)  
operating system [ref1](#)  
passports [ref1](#), [ref2](#), [ref3](#), [ref4](#)  
Pfizer/BioNTech [ref1](#), [ref2](#), [ref3](#), [ref4](#), [ref5](#), [ref6](#), [ref7](#)  
polyethylene glycol [ref1](#)  
pregnant women [ref1](#)  
psychopathic personality [ref1](#)  
races, targeting different [ref1](#)  
reverse transcription [ref1](#)  
Smart Grid [ref1](#)  
social distancing [ref1](#)  
social media [ref1](#)  
sterility [ref1](#)  
synthetic material, introduction of [ref1](#)  
tests [ref1](#), [ref2](#), [ref3](#)  
travel restrictions [ref1](#)  
**variants** [ref1](#), [ref2](#)  
**viruses, existence of** [ref1](#)  
whistle-blowing [ref1](#)

WHO [ref1](#), [ref2](#), [ref3](#), [ref4](#)  
Wokeness [ref1](#)  
working, vaccine as [ref1](#)  
young people [ref1](#)  
**Vallance, Patrick** [ref1](#), [ref2](#), [ref3](#), [ref4](#), [ref5](#), [ref6](#), [ref7](#), [ref8](#), [ref9](#)  
variants [ref1](#), [ref2](#), [ref3](#)  
vegans [ref1](#)  
ventilators [ref1](#), [ref2](#)  
virology [ref1](#), [ref2](#)  
virtual reality [ref1](#), [ref2](#), [ref3](#)  
viruses, existence of [ref1](#)  
visual reality [ref1](#), [ref2](#)  
vitamin D [ref1](#), [ref2](#)  
von Braun, Wernher [ref1](#), [ref2](#)

## **W**

war-zone hospital myths [ref1](#)  
waveforms [ref1](#), [ref2](#)  
wealth [ref1](#), [ref2](#), [ref3](#), [ref4](#), [ref5](#), [ref6](#), [ref7](#), [ref8](#), [ref9](#) [ref10](#), [ref11](#)  
wet market conspiracy [ref1](#)  
**Wetiko factor** [ref1](#)  
    alcoholism and drug addiction [ref1](#)  
    anti-human, why Global Cult is [ref1](#)  
    Archons [ref1](#), [ref2](#), [ref3](#), [ref4](#)  
    artificial intelligence (AI) [ref1](#)  
    Big Pharma [ref1](#), [ref2](#)  
    children [ref1](#)  
    China [ref1](#)  
    consciousness [ref1](#), [ref2](#)  
    education [ref1](#)  
    Facebook [ref1](#)

fear [ref1](#), [ref2](#)  
frequency [ref1](#), [ref2](#)  
Gates [ref1](#), [ref2](#)  
Global Cult [ref1](#), [ref2](#)  
heart [ref1](#), [ref2](#)  
lockdowns [ref1](#)  
masks [ref1](#)  
Native American concept [ref1](#)  
psychopathic personality [ref1](#), [ref2](#)  
reframing/retraining programmes [ref1](#)  
religion [ref1](#)  
Silicon Valley [ref1](#)  
Smart Grid [ref1](#)  
smartphone addiction [ref1](#), [ref2](#)  
social media [ref1](#)  
war [ref1](#), [ref2](#)  
WHO [ref1](#)  
Wokeness [ref1](#), [ref2](#), [ref3](#)  
Yaldabaoth [ref1](#), [ref2](#), [ref3](#), [ref4](#)  
**whistle-blowing** [ref1](#), [ref2](#), [ref3](#), [ref4](#), [ref5](#), [ref6](#), [ref7](#)  
**white privilege** [ref1](#), [ref2](#)  
**white supremacy** [ref1](#), [ref2](#), [ref3](#), [ref4](#), [ref5](#)  
**Whitty, Christopher** [ref1](#), [ref2](#), [ref3](#), [ref4](#), [ref5](#), [ref6](#), [ref7](#), [ref8](#), [ref9](#),  
[ref10](#)  
**'who benefits'** [ref1](#)  
**Wi-Fi** [ref1](#), [ref2](#), [ref3](#), [ref4](#)  
**Wikipedia** [ref1](#), [ref2](#)  
**Wojcicki, Susan** [ref1](#), [ref2](#), [ref3](#), [ref4](#), [ref5](#), [ref6](#), [ref7](#)  
**Wokeness**  
Antifa [ref1](#), [ref2](#), [ref3](#), [ref4](#)  
anti-Semitism [ref1](#)  
billionaire social justice warriors [ref1](#), [ref2](#), [ref3](#)

Capitol Hill riot [ref1](#), [ref2](#)  
censorship [ref1](#)  
Christianity [ref1](#)  
climate change hoax [ref1](#), [ref2](#)  
culture [ref1](#)  
education, control of [ref1](#)  
emotion [ref1](#)  
facts [ref1](#)  
fascism [ref1](#), [ref2](#), [ref3](#)  
Global Cult [ref1](#), [ref2](#), [ref3](#), [ref4](#)  
group-think [ref1](#)  
immigration [ref1](#)  
indigenous people, solidarity with [ref1](#)  
inversion [ref1](#), [ref2](#), [ref3](#)  
left, hijacking the [ref1](#), [ref2](#)  
Marxism [ref1](#), [ref2](#), [ref3](#)  
mind control [ref1](#)  
New Woke [ref1](#)  
Old Woke [ref1](#)  
Oneness [ref1](#)  
perceptual programming [ref1](#)  
    Phantom Self [ref1](#)  
police [ref1](#)  
defunding the [ref1](#)  
reframing [ref1](#)  
public institutions [ref1](#)  
Pushbackers [ref1](#), [ref2](#), [ref3](#)  
racism [ref1](#), [ref2](#), [ref3](#)  
reframing [ref1](#), [ref2](#)  
religion, as [ref1](#)  
Sabbatians [ref1](#), [ref2](#), [ref3](#)  
Silicon Valley [ref1](#)  
social justice [ref1](#), [ref2](#), [ref3](#), [ref4](#)

transgender [ref1](#), [ref2](#), [ref3](#), [ref4](#), [ref5](#)

United States [ref1](#), [ref2](#)

vaccines [ref1](#)

Wetiko factor [ref1](#), [ref2](#), [ref3](#)

young people [ref1](#), [ref2](#), [ref3](#)

women, deletion of rights and status of [ref1](#), [ref2](#)

World Economic Forum (WEF) [ref1](#), [ref2](#), [ref3](#), [ref4](#), [ref5](#), [ref6](#), [ref7](#),  
[ref8](#), [ref9](#)

World Health Organization (WHO) [ref1](#), [ref2](#), [ref3](#), [ref4](#), [ref5](#), [ref6](#),  
[ref7](#), [ref8](#), [ref9](#)

AIDs/HIV [ref1](#)

amplification cycles [ref1](#)

Big Pharma [ref1](#), [ref2](#), [ref3](#)

cooperation in health emergencies [ref1](#)

creation [ref1](#), [ref2](#)

fatality rate [ref1](#)

funding [ref1](#), [ref2](#), [ref3](#)

Gates [ref1](#)

Internet [ref1](#)

lockdown [ref1](#)

vaccines [ref1](#), [ref2](#), [ref3](#), [ref4](#)

Wetiko factor [ref1](#)

world number 1 (masses) [ref1](#), [ref2](#)

world number 2 [ref1](#)

Wuhan [ref1](#), [ref2](#), [ref3](#), [ref4](#), [ref5](#), [ref6](#), [ref7](#) [ref8](#)

## Y

Yaldabaoth [ref1](#), [ref2](#), [ref3](#), [ref4](#), [ref5](#), [ref6](#)

Yeadon, Michael [ref1](#), [ref2](#), [ref3](#), [ref4](#)

young people *see also* children addiction to technology [ref1](#)

Human 2.0 [ref1](#)

vaccines [ref1](#), [ref2](#)

Wokeness [ref1](#), [ref2](#), [ref3](#)

YouTube [ref1](#), [ref2](#), [ref3](#), [ref4](#), [ref5](#)

WHO 548

## **Z**

Zaks, Tal [ref1](#)

Zionism [ref1](#), [ref2](#), [ref3](#)

Zuckerberg, Mark [ref1](#), [ref2](#), [ref3](#), [ref4](#), [ref5](#), [ref6](#), [ref7](#), [ref8](#), [ref9](#),  
[ref10](#), [ref11](#), [ref12](#)

Zulus [ref1](#)

# **ICKONIC** **THE ALTERNATIVE**

Ickonic is something that has been a dream of mine for the last 5 years, growing up around alternative information I have always had a natural interest in what is going on in the World and what could I do to make it better.

Across the range of subjects and positions of influence occupied mainly by people who don't strive to make things better it's the Media that I have always found the most frustrating and fascinating. Mainly because if the Media did their Jobs properly then so much of the negative things happening in the World simply would not be able to happen, because they would be exposed within a heartbeat.

Free Press and the Opportunities that the internet could have given would mean that the Media are able to expose things like never before and hold people to account for their actions. As we all know there are 'Untouchables' that walk among us, people the Media simply won't touch, expose or investigate and that leads to the dark underworlds that infest the establishment the World over. Well I say enough, it's time for something different, a different kind of Media, where no one is off limits from exposing and investigating. All we're interested in at Ickonic is the truth of what is really going on in the World on whichever subject we're covering.

We hope you enjoy what we have created and take something away from the platform, we aim to deliver information that's informative and most importantly self-empowering, you're not a little person, you're part of something much bigger than that and its time we as a collective race began to understand that and look to the future as ours to take.

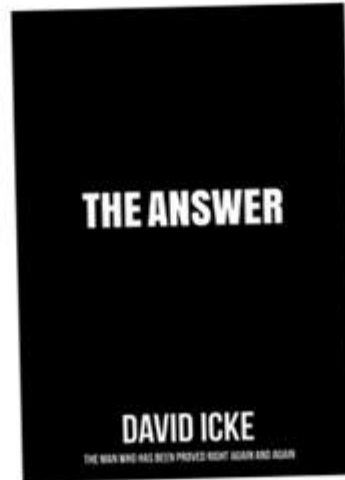
It's time...

Jaymie Icke - Founder Ickonic Alternative Media.

**SIGN UP NOW AT [ICKONIC.COM](http://ICKONIC.COM)**



DAVID ICKE  
**THE ANSWER**



We live in extraordinary times with billions bewildered and seeking answers for what is happening. David Icke, the man who has been proved right again and again, has spent 30 years uncovering the truth behind world affairs and in a stream of previous books he predicted current events.

The Answer will change your every perception of life and the world and set you free of the illusions that control human society. There is nothing more vital for our collective freedom than humanity becoming aware of what is in this book.

**Available now at [davidicke.com](http://davidicke.com).**

# THE TRIGGER

THE LIE THAT CHANGED THE WORLD  
- WHO REALLY DID IT AND WHY



DAVID ICKE



**EVERYTHING  
YOU NEED  
TO KNOW**

**BUT HAVE NEVER BEEN TOLD**

**DAVID ICKE**

**DAVIDICKE.COM**



**DAVID ICKE STORE**  
**LATEST NEWS ARTICLES**  
**DAVID ICKE VIDEOS**  
**WEEKLY DOT-CONNECTOR PODCASTS**  
**LIVE EVENTS**

[WWW.DAVIDICKE.COM](http://WWW.DAVIDICKE.COM)

THE LIFE STORY OF DAVID ICKE

# RENEGADE

THE FEATURE LENGTH FILM

/ˈren·iˌgeɪd/

**noun**

A person who behaves in a rebelliously unconventional manner.



**AVAILABLE NOW AT DAVIDICKE.COM**

2 NEW BOOKS  
BY NEIL HAGUE

# ORION'S DOOR

SYMBOLS OF CONSCIOUSNESS & BLUEPRINTS OF CONTROL  
- THE STORY OF ORION'S INFLUENCE OVER HUMANITY

CUTTING EDGE VISIONARY ART  
& UNIQUE ILLUSTRATED BOOKS

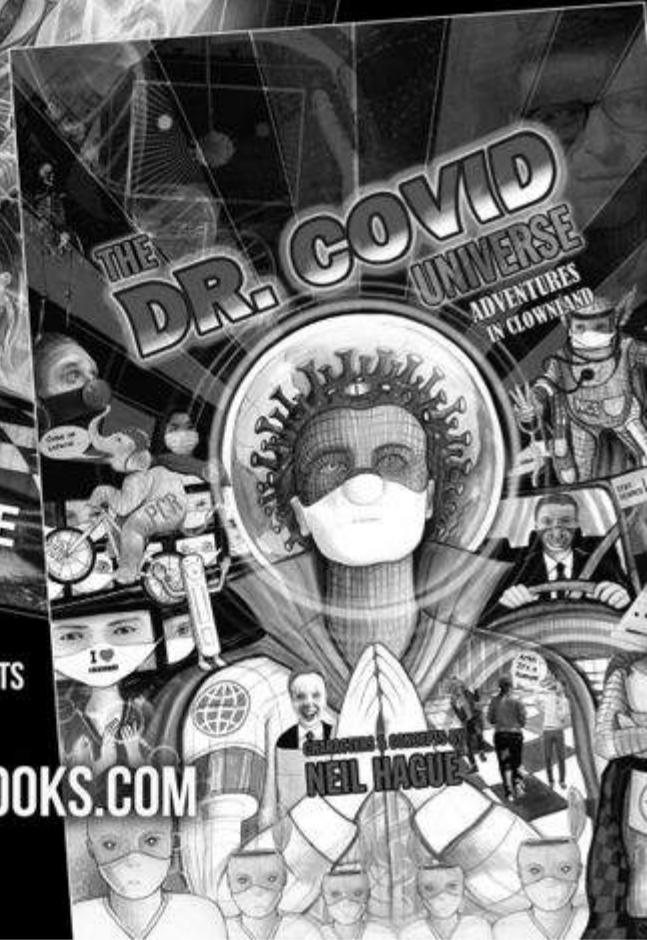
NEIL HAGUE

FOR  
BOOKS, PRINTS & T-SHIRTS

VISIT:

[NEILHAGUEBOOKS.COM](http://NEILHAGUEBOOKS.COM)

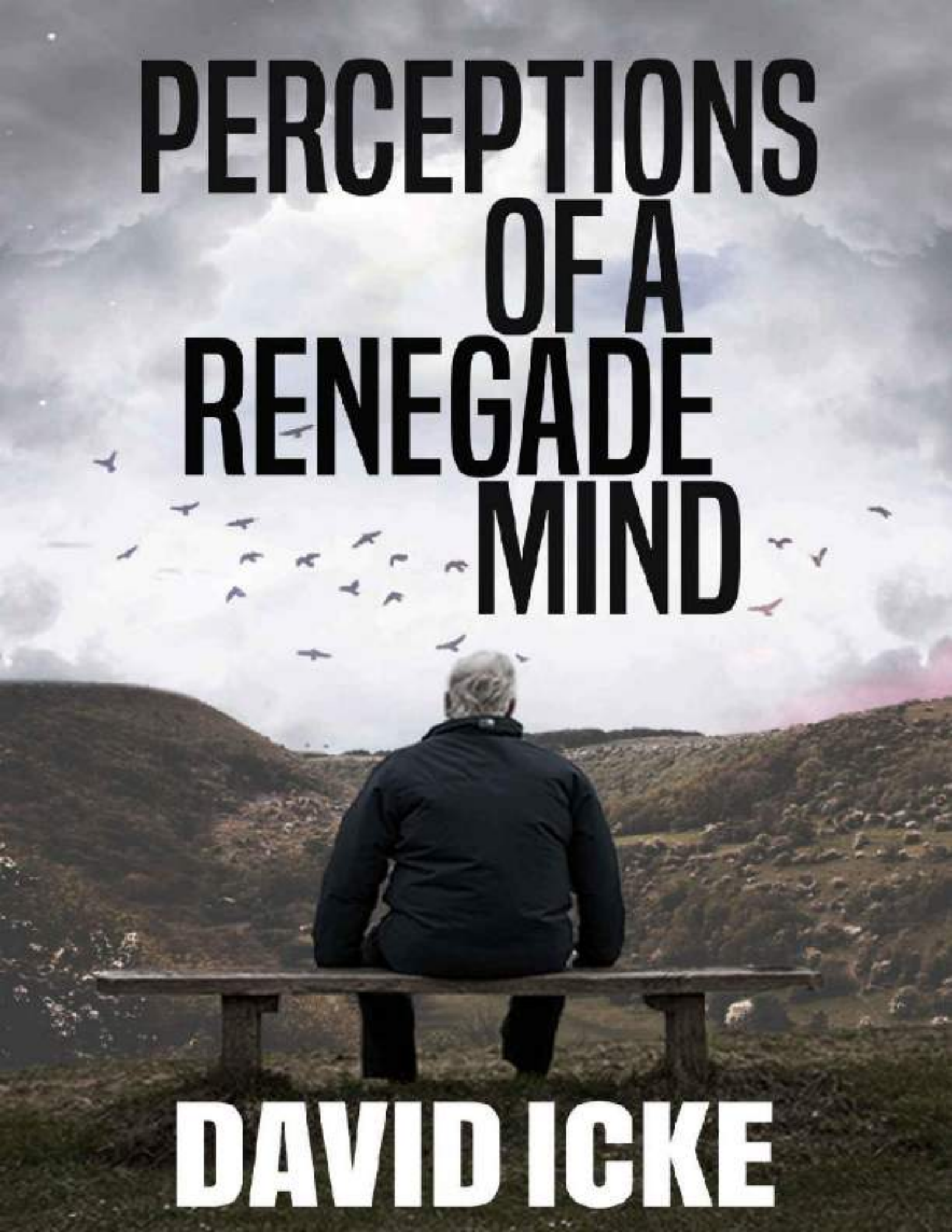
OR [NEILHAGUE.COM](http://NEILHAGUE.COM)



## **Before you go ...**

For more detail, background and evidence about the subjects in *Perceptions of a Renegade Mind* – and so much more – see my others books including *And The Truth Shall Set You Free*; *The Biggest Secret*; *Children of the Matrix*; *The David Icke Guide to the Global Conspiracy*; *Tales from the Time Loop*; *The Perception Deception*; *Remember Who You Are*; *Human Race Get Off Your Knees*; *Phantom Self*; *Everything You Need To Know But Have Never Been Told*, *The Trigger* and *The Answer*.

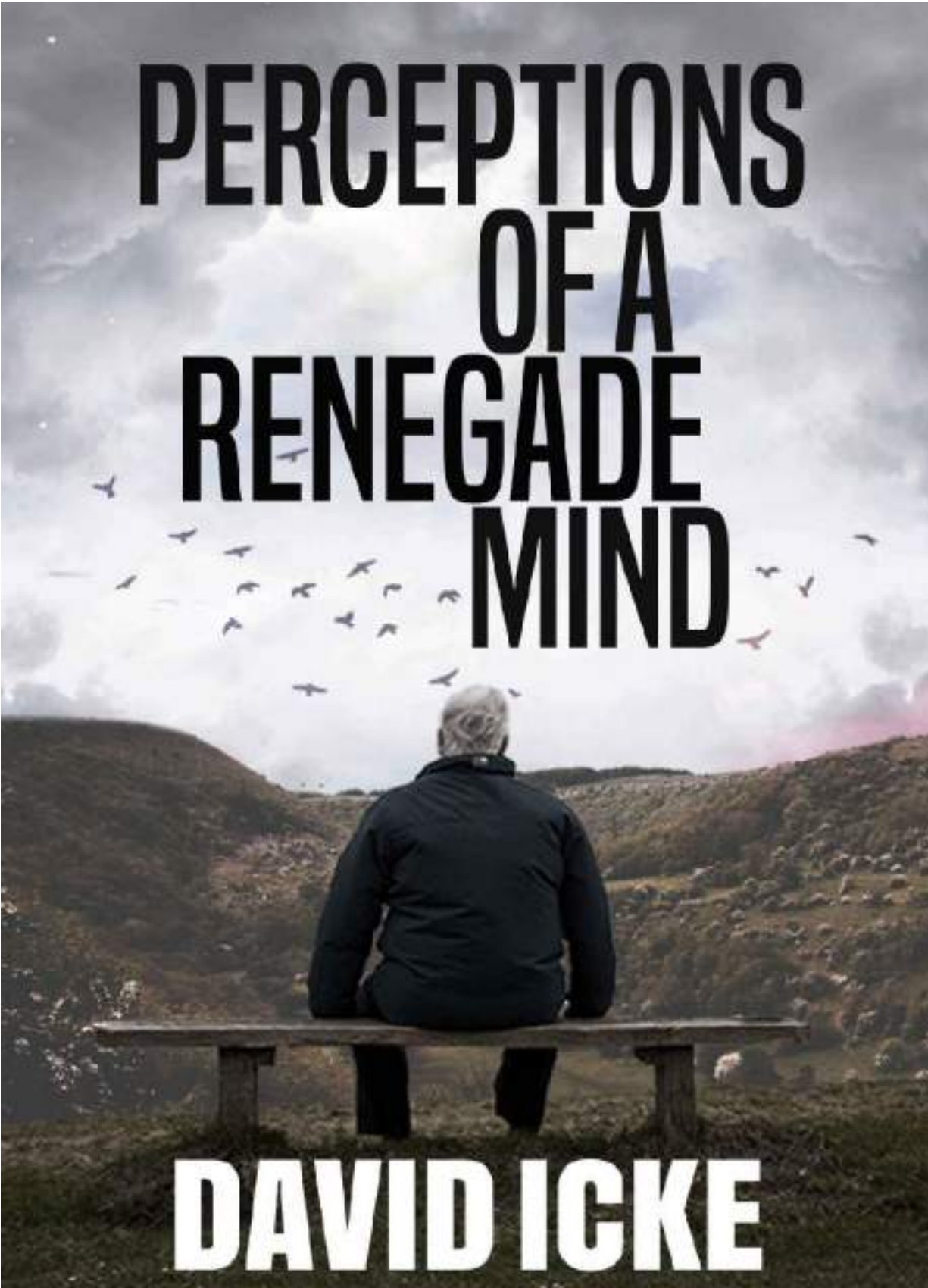
You can subscribe to the fantastic new Ickonic media platform where there are many hundreds of hours of cutting-edge information in videos, documentaries and series across a whole range of subjects which are added to every week. This includes my 90 minute breakdown of the week's news every Friday to explain *why* events are happening and to what end.

A person with grey hair, wearing a dark jacket, is seen from behind, sitting on a wooden bench. They are looking out over a vast, open landscape of rolling hills and fields. The sky is filled with many birds in flight, and the overall atmosphere is contemplative and serene. The text is overlaid on the top half of the image.

# PERCEPTIONS OF A RENEGADE MIND

**DAVID ICKE**



A person with grey hair, wearing a dark jacket, is sitting on a wooden bench, viewed from behind. They are looking out over a landscape of rolling hills with sparse vegetation. The sky is filled with many birds in flight, and there are large, dark, bold letters overlaid on the sky. The overall mood is contemplative and expansive.

# PERCEPTIONS OF A RENEGADE MIND

**DAVID ICKE**

**PERCEPTIONS  
OF A  
RENEGADE  
MIND**



ickonic  
publishing

First published in July 2021.

ickonic  
publishing

**New Enterprise House  
St Helens Street  
Derby  
DE1 3GY  
UK**

*email:* [gareth.icke@davidicke.com](mailto:gareth.icke@davidicke.com)

Copyright © 2021 David Icke

No part of this book may be reproduced in any form without permission from the  
Publisher, except for the quotation of brief passages in criticism

*Cover Design:* Gareth Icke

*Book Design:* Neil Hague

**British Library Cataloguing-in  
Publication Data**

A catalogue record for this book is  
available from the British Library

eISBN 978-18384153-1-0

**PERCEPTIONS  
OF A  
RENEGADE  
MIND**

A flock of small, dark birds is scattered around the bottom half of the title text, appearing to fly in various directions.

**DAVID ICKE**

**Dedication:**

***To Freeeeedom!***

# **ICKONIC** **THE ALTERNATIVE**

**NEW. DIFFERENT. REVOLUTIONARY**

**HUNDREDS OF CUTTING EDGE DOCUMENTARIES,  
FEATURE FILMS, SERIES & PODCASTS.**

**SIGN UP NOW AT [ICKONIC.COM](http://ICKONIC.COM)**

THE LIFE STORY OF DAVID ICKE  
**RENEGADE**  
THE FEATURE LENGTH FILM



AVAILABLE NOW AT [DAVIDICKE.COM](http://DAVIDICKE.COM)

**Renegade:**

Adjective

'Having rejected tradition: Unconventional.'

**Merriam-Webster Dictionary**



## **Acquiescence to tyranny is the death of the spirit**

You may be 38 years old, as I happen to be. And one day, some great opportunity stands before you and calls you to stand up for some great principle, some great issue, some great cause. And you refuse to do it because you are afraid ... You refuse to do it because you want to live longer ... You're afraid that you will lose your job, or you are afraid that you will be criticised or that you will lose your popularity, or you're afraid that somebody will stab you, or shoot at you or bomb your house; so you refuse to take the stand.

Well, you may go on and live until you are 90, but you're just as dead at 38 as you would be at 90. And the cessation of breathing in your life is but the belated announcement of an earlier death of the spirit.

**Martin Luther King**

**How the few control the many and always have – the many do  
whatever they're told**

'Forward, the Light Brigade!'  
Was there a man dismayed?  
Not though the soldier knew  
Someone had blundered.  
Theirs not to make reply,  
Theirs not to reason why,  
Theirs but to do and die.  
Into the valley of Death  
Rode the six hundred.

Cannon to right of them,  
Cannon to left of them,  
Cannon in front of them  
Volleyed and thundered;  
Stormed at with shot and shell,  
Boldly they rode and well,  
Into the jaws of Death,  
Into the mouth of hell  
Rode the six hundred

**Alfred Lord Tennyson (1809-1892)**

The mist is lifting slowly  
I can see the way ahead  
And I've left behind the empty streets  
That once inspired my life  
And the strength of the emotion  
Is like thunder in the air  
'Cos the promise that we made each other  
Haunts me to the end

The secret of your beauty  
And the mystery of your soul  
I've been searching for in everyone I meet  
And the times I've been mistaken  
It's impossible to say  
And the grass is growing  
Underneath our feet

The words that I remember  
From my childhood still are true  
That there's none so blind  
As those who will not see  
And to those who lack the courage  
And say it's dangerous to try  
Well they just don't know  
That love eternal will not be denied

I know you're out there somewhere  
Somewhere, somewhere  
I know you're out there somewhere

Somewhere you can hear my voice  
I know I'll find you somehow  
Somehow, somehow  
I know I'll find you somehow  
And somehow I'll return again to you

**The Moody Blues**

**Are you a gutless wonder - or a Renegade Mind?**

Monuments put from pen to paper,  
Turns me into a gutless wonder,  
And if you tolerate this,  
Then your children will be next.  
Gravity keeps my head down,  
Or is it maybe shame ...

**Manic Street Preachers**

Rise like lions after slumber  
In unvanquishable number.  
Shake your chains to earth like dew  
Which in sleep have fallen on you.  
Ye are many – they are few.

**Percy Shelley**

# Contents

CHAPTER 1	'I'm thinking' – Oh, but <i>are</i> you?
CHAPTER 2	Renegade perception
CHAPTER 3	The Pushbacker sting
CHAPTER 4	'Covid': The calculated catastrophe
CHAPTER 5	There <i>is no</i> 'virus'
CHAPTER 6	Sequence of deceit
CHAPTER 7	War on your mind
CHAPTER 8	'Reframing' insanity
CHAPTER 9	We must have it? So what is it?
CHAPTER 10	Human 2.0
CHAPTER 11	Who controls the Cult?
CHAPTER 12	Escaping Wetiko
POSTSCRIPT	
APPENDIX	Cowan-Kaufman-Morell Statement on Virus Isolation
BIBLIOGRAPHY	
INDEX	

## CHAPTER ONE

### **I'm thinking' – Oh, but *are* you?**

*Think for yourself and let others enjoy the privilege of doing so too*  
Voltaire

**F**rench-born philosopher, mathematician and scientist René Descartes became famous for his statement in Latin in the 17th century which translates into English as: 'I think, therefore I am.'

On the face of it that is true. Thought reflects perception and perception leads to both behaviour and self-identity. In that sense 'we' are what we think. But who or what is doing the thinking and is thinking the only route to perception? Clearly, as we shall see, 'we' are not always the source of 'our' perception, indeed with regard to humanity as a whole this is rarely the case; and thinking is far from the only means of perception. Thought is the village idiot compared with other expressions of consciousness that we all have the potential to access and tap into. This has to be true when we *are* those other expressions of consciousness which are infinite in nature. We have forgotten this, or, more to the point, been manipulated to forget.

These are not just the esoteric musings of the navel. The whole foundation of human control and oppression is control of perception. Once perception is hijacked then so is behaviour which is dictated by perception. Collective perception becomes collective behaviour and collective behaviour is what we call human society. Perception is all and those behind human control know that which is

why perception is the target 24/7 of the psychopathic manipulators that I call the Global Cult. They know that if they dictate perception they will dictate behaviour and collectively dictate the nature of human society. They are further aware that perception is formed from information received and if they control the circulation of information they will to a vast extent direct human behaviour. Censorship of information and opinion has become globally Nazi-like in recent years and never more blatantly than since the illusory 'virus pandemic' was triggered out of China in 2019 and across the world in 2020. Why have billions submitted to house arrest and accepted fascistic societies in a way they would have never believed possible? Those controlling the information spewing from government, mainstream media and Silicon Valley (all controlled by the same Global Cult networks) told them they were in danger from a 'deadly virus' and only by submitting to house arrest and conceding their most basic of freedoms could they and their families be protected. This monumental and provable lie became the *perception* of the billions and therefore the *behaviour* of the billions. In those few words you have the whole structure and modus operandi of human control. Fear is a perception – False Emotion Appearing Real – and fear is the currency of control. In short ... get them by the balls (or give them the impression that you have) and their hearts and minds will follow. Nothing grips the dangly bits and freezes the rear-end more comprehensively than fear.

## **World number 1**

There are two 'worlds' in what appears to be one 'world' and the prime difference between them is knowledge. First we have the mass of human society in which the population is maintained in coldly-calculated ignorance through control of information and the 'education' (indoctrination) system. That's all you really need to control to enslave billions in a perceptual delusion in which what are perceived to be *their* thoughts and opinions are ever-repeated mantras that the system has been downloading all their lives through 'education', media, science, medicine, politics and academia



in which the personnel and advocates are themselves overwhelmingly the perceptual products of the same repetition. Teachers and academics in general are processed by the same programming machine as everyone else, but unlike the great majority they never leave the 'education' program. It gripped them as students and continues to grip them as programmers of subsequent generations of students. The programmed become the programmers – the programmed programmers. The same can largely be said for scientists, doctors and politicians and not least because as the American writer Upton Sinclair said: 'It is difficult to get a man to understand something when his salary depends upon his not understanding it.' If your career and income depend on thinking the way the system demands then you will – bar a few free-minded exceptions – concede your mind to the Perceptual Mainframe that I call the Postage Stamp Consensus. This is a tiny band of perceived knowledge and possibility 'taught' (downloaded) in the schools and universities, pounded out by the mainstream media and on which all government policy is founded. Try thinking, and especially speaking and acting, outside of the 'box' of consensus and see what that does for your career in the Mainstream Everything which bullies, harasses, intimidates and ridicules the population into compliance. Here we have the simple structure which enslaves most of humanity in a perceptual prison cell for an entire lifetime and I'll go deeper into this process shortly. Most of what humanity is taught as fact is nothing more than programmed belief. American science fiction author Frank Herbert was right when he said: 'Belief can be manipulated. Only knowledge is dangerous.' In the 'Covid' age belief is promoted and knowledge is censored. It was always so, but never to the extreme of today.

## **World number 2**

A 'number 2' is slang for 'doing a poo' and how appropriate that is when this other 'world' is doing just that on humanity every minute of every day. World number 2 is a global network of secret societies and semi-secret groups dictating the direction of society via

governments, corporations and authorities of every kind. I have spent more than 30 years uncovering and exposing this network that I call the Global Cult and knowing its agenda is what has made my books so accurate in predicting current and past events. Secret societies are secret for a reason. They want to keep their hoarded knowledge to themselves and their chosen initiates and to hide it from the population which they seek through ignorance to control and subdue. The whole foundation of the division between World 1 and World 2 is *knowledge*. What number 1 knows number 2 must not. Knowledge they have worked so hard to keep secret includes (a) the agenda to enslave humanity in a centrally-controlled global dictatorship, and (b) the nature of reality and life itself. The latter (b) must be suppressed to allow the former (a) to prevail as I shall be explaining. The way the Cult manipulates and interacts with the population can be likened to a spider's web. The 'spider' sits at the centre in the shadows and imposes its will through the web with each strand represented in World number 2 by a secret society, satanic or semi-secret group, and in World number 1 – the world of the seen – by governments, agencies of government, law enforcement, corporations, the banking system, media conglomerates and Silicon Valley (Fig 1 overleaf). The spider and the web connect and coordinate all these organisations to pursue the same global outcome while the population sees them as individual entities working randomly and independently. At the level of the web governments *are* the banking system *are* the corporations *are* the media *are* Silicon Valley *are* the World Health Organization working from their inner cores as one unit. Apparently unconnected countries, corporations, institutions, organisations and people are on the *same team* pursuing the same global outcome. Strands in the web immediately around the spider are the most secretive and exclusive secret societies and their membership is emphatically restricted to the Cult inner-circle emerging through the generations from particular bloodlines for reasons I will come to. At the core of the core you would get them in a single room. That's how many people are dictating the direction of human society and its transformation

through the 'Covid' hoax and other means. As the web expands out from the spider we meet the secret societies that many people will be aware of – the Freemasons, Knights Templar, Knights of Malta, Opus Dei, the inner sanctum of the Jesuit Order, and such like. Note how many are connected to the Church of Rome and there is a reason for that. The Roman Church was established as a revamp, a rebranding, of the relocated 'Church' of Babylon and the Cult imposing global tyranny today can be tracked back to Babylon and Sumer in what is now Iraq.



**Figure 1:** The global web through which the few control the many. (Image Neil Hague.)

Inner levels of the web operate in the unseen away from the public eye and then we have what I call the cusp organisations located at the point where the hidden meets the seen. They include a series of satellite organisations answering to a secret society founded in London in the late 19th century called the Round Table and among them are the Royal Institute of International Affairs (UK, founded in 1920); Council on Foreign Relations (US, 1921); Bilderberg Group (worldwide, 1954); Trilateral Commission (US/worldwide, 1972); and the Club of Rome (worldwide, 1968) which was created to exploit environmental concerns to justify the centralisation of global power to 'save the planet'. The Club of Rome instigated with others the human-caused climate change hoax which has led to all the 'green

new deals' demanding that very centralisation of control. Cusp organisations, which include endless 'think tanks' all over the world, are designed to coordinate a single global policy between political and business leaders, intelligence personnel, media organisations and anyone who can influence the direction of policy in their own sphere of operation. Major players and regular attenders will know what is happening – or some of it – while others come and go and are kept overwhelmingly in the dark about the big picture. I refer to these cusp groupings as semi-secret in that they can be publicly identified, but what goes on at the inner-core is kept very much 'in house' even from most of their members and participants through a fiercely-imposed system of compartmentalisation. Only let them know what they need to know to serve your interests and no more. The structure of secret societies serves as a perfect example of this principle. Most Freemasons never get higher than the bottom three levels of 'degree' (degree of knowledge) when there are 33 official degrees of the Scottish Rite. Initiates only qualify for the next higher 'compartment' or degree if those at that level choose to allow them. Knowledge can be carefully assigned only to those considered 'safe'. I went to my local Freemason's lodge a few years ago when they were having an 'open day' to show how cuddly they were and when I chatted to some of them I was astonished at how little the rank and file knew even about the most ubiquitous symbols they use. The mushroom technique – keep them in the dark and feed them bullshit – applies to most people in the web as well as the population as a whole. Sub-divisions of the web mirror in theme and structure transnational corporations which have a headquarters somewhere in the world dictating to all their subsidiaries in different countries. Subsidiaries operate in their methodology and branding to the same centrally-dictated plan and policy in pursuit of particular ends. The Cult web functions in the same way. Each country has its own web as a subsidiary of the global one. They consist of networks of secret societies, semi-secret groups and bloodline families and their job is to impose the will of the spider and the global web in their particular country. Subsidiary networks control and manipulate the national political system, finance, corporations, media, medicine, etc. to

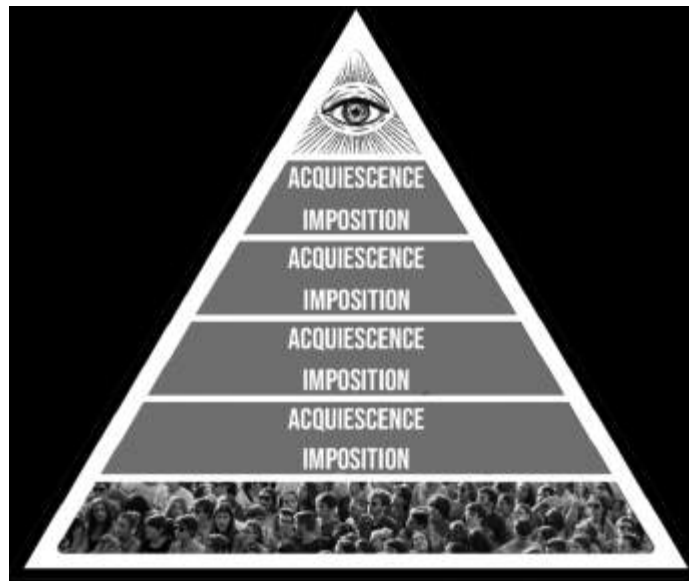
ensure that they follow the globally-dictated Cult agenda. These networks were the means through which the 'Covid' hoax could be played out with almost every country responding in the same way.

## **The 'Yessir' pyramid**

Compartmentalisation is the key to understanding how a tiny few can dictate the lives of billions when combined with a top-down sequence of imposition and acquiescence. The inner core of the Cult sits at the peak of the pyramidal hierarchy of human society (Fig 2 overleaf). It imposes its will – its agenda for the world – on the level immediately below which acquiesces to that imposition. This level then imposes the Cult will on the level below them which acquiesces and imposes on the next level. Very quickly we meet levels in the hierarchy that have no idea there even is a Cult, but the sequence of imposition and acquiescence continues down the pyramid in just the same way. 'I don't know why we are doing this but the order came from "on-high" and so we better just do it.' Alfred Lord Tennyson said of the cannon fodder levels in his poem *The Charge of the Light Brigade*: 'Theirs not to reason why; theirs but to do and die.' The next line says that 'into the valley of death rode the six hundred' and they died because they obeyed without question what their perceived 'superiors' told them to do. In the same way the population capitulated to 'Covid'. The whole hierarchical pyramid functions like this to allow the very few to direct the enormous many.

Eventually imposition-acquiescence-imposition-acquiescence comes down to the mass of the population at the foot of the pyramid. If they acquiesce to those levels of the hierarchy imposing on them (governments/law enforcement/doctors/media) a circuit is completed between the population and the handful of super-psychopaths in the Cult inner core at the top of the pyramid. Without a circuit-breaking refusal to obey, the sequence of imposition and acquiescence allows a staggeringly few people to impose their will upon the entirety of humankind. We are looking at the very sequence that has subjugated billions since the start of 2020. Our freedom has not been taken from us. Humanity has given it

away. Fascists do not impose fascism because there are not enough of them. Fascism is imposed by the population acquiescing to fascism. Put another way allowing their perceptions to be programmed to the extent that leads to the population giving their freedom away by giving their perceptions – their mind – away. If this circuit is not broken by humanity ceasing to cooperate with their own enslavement then nothing can change. For that to happen people have to critically think and see through the lies and window dressing and then summon the backbone to act upon what they see. The Cult spends its days working to stop either happening and its methodology is systematic and highly detailed, but it can be overcome and that is what this book is all about.



**Figure 2:** The simple sequence of imposition and compliance that allows a handful of people at the peak of the pyramid to dictate the lives of billions.

## **The Life Program**

Okay, back to world number 1 or the world of the ‘masses’. Observe the process of what we call ‘life’ and it is a perceptual download from cradle to grave. The Cult has created a global structure in which perception can be programmed and the program continually topped-up with what appears to be constant confirmation that the program is indeed true reality. The important word here is ‘appears’.

This is the structure, the fly-trap, the Postage Stamp Consensus or Perceptual Mainframe, which represents that incredibly narrow band of perceived possibility delivered by the 'education' system, mainstream media, science and medicine. From the earliest age the download begins with parents who have themselves succumbed to the very programming their children are about to go through. Most parents don't do this out of malevolence and mostly it is quite the opposite. They do what they believe is best for their children and that is what the program has told them is best. Within three or four years comes the major transition from parental programming to full-blown state (Cult) programming in school, college and university where perceptually-programmed teachers and academics pass on their programming to the next generations. Teachers who resist are soon marginalised and their careers ended while children who resist are called a problem child for whom Ritalin may need to be prescribed. A few years after entering the 'world' children are under the control of authority figures representing the state telling them when they have to be there, when they can leave and when they can speak, eat, even go to the toilet. This is calculated preparation for a lifetime of obeying authority in all its forms. Reflex-action fear of authority is instilled by authority from the start. Children soon learn the carrot and stick consequences of obeying or defying authority which is underpinned daily for the rest of their life. Fortunately I daydreamed through this crap and never obeyed authority simply because it told me to. This approach to my alleged 'betters' continues to this day. There can be consequences of pursuing open-minded freedom in a world of closed-minded conformity. I spent a lot of time in school corridors after being ejected from the classroom for not taking some of it seriously and now I spend a lot of time being ejected from Facebook, YouTube and Twitter. But I can tell you that being true to yourself and not compromising your self-respect is far more exhilarating than bowing to authority for authority's sake. You don't have to be a sheep to the shepherd (authority) and the sheep dog (fear of not obeying authority).

The perceptual download continues throughout the formative years in school, college and university while script-reading 'teachers', 'academics' 'scientists', 'doctors' and 'journalists' insist that ongoing generations must be as programmed as they are. Accept the program or you will not pass your 'exams' which confirm your 'degree' of programming. It is tragic to think that many parents pressure their offspring to work hard at school to download the program and qualify for the next stage at college and university. The late, great, American comedian George Carlin said: 'Here's a bumper sticker I'd like to see: We are proud parents of a child who has resisted his teachers' attempts to break his spirit and bend him to the will of his corporate masters.' Well, the best of luck finding many of those, George. Then comes the moment to leave the formal programming years in academia and enter the 'adult' world of work. There you meet others in your chosen or prescribed arena who went through the same Postage Stamp Consensus program before you did. There is therefore overwhelming agreement between almost everyone on the basic foundations of Postage Stamp reality and the rejection, even contempt, of the few who have a mind of their own and are prepared to use it. This has two major effects. Firstly, the consensus confirms to the programmed that their download is really how things are. I mean, everyone knows that, right? Secondly, the arrogance and ignorance of Postage Stamp adherents ensure that anyone questioning the program will have unpleasant consequences for seeking their own truth and not picking their perceptions from the shelf marked: 'Things you must believe without question and if you don't you're a dangerous lunatic conspiracy theorist and a harebrained nutter'.

Every government, agency and corporation is founded on the same Postage Stamp prison cell and you can see why so many people believe the same thing while calling it their own 'opinion'. Fusion of governments and corporations in pursuit of the same agenda was the definition of fascism described by Italian dictator Benito Mussolini. The pressure to conform to perceptual norms downloaded for a lifetime is incessant and infiltrates society right



down to family groups that become censors and condemners of their own 'black sheep' for not, ironically, being sheep. We have seen an explosion of that in the 'Covid' era. Cult-owned global media unleashes its propaganda all day every day in support of the Postage Stamp and targets with abuse and ridicule anyone in the public eye who won't bend their mind to the will of the tyranny. Any response to this is denied (certainly in my case). They don't want to give a platform to expose official lies. Cult-owned-and-created Internet giants like Facebook, Google, YouTube and Twitter delete you for having an unapproved opinion. Facebook boasts that its AI censors delete 97-percent of 'hate speech' before anyone even reports it. Much of that 'hate speech' will simply be an opinion that Facebook and its masters don't want people to see. Such perceptual oppression is widely known as fascism. Even Facebook executive Benny Thomas, a 'CEO Global Planning Lead', said in comments secretly recorded by investigative journalism operation Project Veritas that Facebook is 'too powerful' and should be broken up:

I mean, no king in history has been the ruler of two billion people, but Mark Zuckerberg is ... And he's 36. That's too much for a 36-year-old ... You should not have power over two billion people. I just think that's wrong.

Thomas said Facebook-owned platforms like Instagram, Oculus, and WhatsApp needed to be separate companies. 'It's too much power when they're all one together'. That's the way the Cult likes it, however. We have an executive of a Cult organisation in Benny Thomas that doesn't know there is a Cult such is the compartmentalisation. Thomas said that Facebook and Google 'are no longer companies, they're countries'. Actually they are more powerful than countries on the basis that if you control information you control perception and control human society.

## **I love my oppressor**

Another expression of this psychological trickery is for those who realise they are being pressured into compliance to eventually

convince themselves to believe the official narratives to protect their self-respect from accepting the truth that they have succumbed to meek and subservient compliance. Such people become some of the most vehement defenders of the system. You can see them everywhere screaming abuse at those who prefer to think for themselves and by doing so reminding the compliers of their own capitulation to conformity. 'You are talking dangerous nonsense you Covidiot!!' Are you trying to convince me or yourself? It is a potent form of Stockholm syndrome which is defined as: 'A psychological condition that occurs when a victim of abuse identifies and attaches, or bonds, positively with their abuser.' An example is hostages bonding and even 'falling in love' with their kidnappers. The syndrome has been observed in domestic violence, abused children, concentration camp inmates, prisoners of war and many and various Satanic cults. These are some traits of Stockholm syndrome listed at [goodtherapy.org](http://goodtherapy.org):

- Positive regard towards perpetrators of abuse or captor [see 'Covid'].
- Failure to cooperate with police and other government authorities when it comes to holding perpetrators of abuse or kidnapping accountable [or in the case of 'Covid' cooperating with the police to enforce and defend their captors' demands].
- Little or no effort to escape [see 'Covid'].
- Belief in the goodness of the perpetrators or kidnappers [see 'Covid'].
- Appeasement of captors. This is a manipulative strategy for maintaining one's safety. As victims get rewarded – perhaps with less abuse or even with life itself – their appeasing behaviours are reinforced [see 'Covid'].
- Learned helplessness. This can be akin to 'if you can't beat 'em, join 'em'. As the victims fail to escape the abuse or captivity, they may start giving up and soon realize it's just easier for everyone if they acquiesce all their power to their captors [see 'Covid'].

- Feelings of pity toward the abusers, believing they are actually victims themselves. Because of this, victims may go on a crusade or mission to 'save' [protect] their abuser [see the venom unleashed on those challenging the official 'Covid' narrative].
- Unwillingness to learn to detach from their perpetrators and heal. In essence, victims may tend to be less loyal to themselves than to their abuser [ *definitely* see 'Covid'].

Ponder on those traits and compare them with the behaviour of great swathes of the global population who have defended governments and authorities which have spent every minute destroying their lives and livelihoods and those of their children and grandchildren since early 2020 with fascistic lockdowns, house arrest and employment deletion to 'protect' them from a 'deadly virus' that their abusers' perceptually created to bring about this very outcome. We are looking at mass Stockholm syndrome. All those that agree to concede their freedom will believe those perceptions are originating in their own independent 'mind' when in fact by conceding their reality to Stockholm syndrome they have by definition conceded any independence of mind. Listen to the 'opinions' of the acquiescing masses in this 'Covid' era and what gushes forth is the repetition of the official version of everything delivered unprocessed, unfiltered and unquestioned. The whole programming dynamic works this way. I must be free because I'm told that I am and so I think that I am.

You can see what I mean with the chapter theme of 'I'm thinking – Oh, but *are* you?' The great majority are not thinking, let alone for themselves. They are repeating what authority has told them to believe which allows them to be controlled. Weaving through this mentality is the fear that the 'conspiracy theorists' are right and this again explains the often hysterical abuse that ensues when you dare to contest the official narrative of anything. Denial is the mechanism of hiding from yourself what you don't want to be true. Telling people what they want to hear is easy, but it's an infinitely greater challenge to tell them what they would rather not be happening.

One is akin to pushing against an open door while the other is met with vehement resistance no matter what the scale of evidence. I don't want it to be true so I'll convince myself that it's not. Examples are everywhere from the denial that a partner is cheating despite all the signs to the reflex-action rejection of any idea that world events in which country after country act in exactly the same way are centrally coordinated. To accept the latter is to accept that a force of unspeakable evil is working to destroy your life and the lives of your children with nothing too horrific to achieve that end. Who the heck wants that to be true? But if we don't face reality the end is duly achieved and the consequences are far worse and ongoing than breaking through the walls of denial today with the courage to make a stand against tyranny.

### **Connect the dots – but how?**

A crucial aspect of perceptual programming is to portray a world in which everything is random and almost nothing is connected to anything else. Randomness cannot be coordinated by its very nature and once you perceive events as random the idea they could be connected is waved away as the rantings of the tinfoil-hat brigade. You can't plan and coordinate random you idiot! No, you can't, but you can hide the coldly-calculated and long-planned behind the *illusion* of randomness. A foundation manifestation of the Renegade Mind is to scan reality for patterns that connect the apparently random and turn pixels and dots into pictures. This is the way I work and have done so for more than 30 years. You look for similarities in people, modus operandi and desired outcomes and slowly, then ever quicker, the picture forms. For instance: There would seem to be no connection between the 'Covid pandemic' hoax and the human-caused global-warming hoax and yet they are masks (appropriately) on the same face seeking the same outcome. Those pushing the global warming myth through the Club of Rome and other Cult agencies are driving the lies about 'Covid' – Bill Gates is an obvious one, but they are endless. Why would the same people be involved in both when they are clearly not connected? Oh, but they

are. Common themes with personnel are matched by common goals. The 'solutions' to both 'problems' are centralisation of global power to impose the will of the few on the many to 'save' humanity from 'Covid' and save the planet from an 'existential threat' (we need 'zero Covid' and 'zero carbon emissions'). These, in turn, connect with the 'dot' of globalisation which was coined to describe the centralisation of global power in every area of life through incessant political and corporate expansion, trading blocks and superstates like the European Union. If you are the few and you want to control the many you have to centralise power and decision-making. The more you centralise power the more power the few at the centre will have over the many; and the more that power is centralised the more power those at the centre have to centralise even quicker. The momentum of centralisation gets faster and faster which is exactly the process we have witnessed. In this way the hoaxed 'pandemic' and the fakery of human-caused global warming serve the interests of globalisation and the seizure of global power in the hands of the Cult inner-circle which is behind 'Covid', 'climate change' and globalisation. At this point random 'dots' become a clear and obvious picture or pattern.

Klaus Schwab, the classic Bond villain who founded the Cult's Gates-funded World Economic Forum, published a book in 2020, *The Great Reset*, in which he used the 'problem' of 'Covid' to justify a total transformation of human society to 'save' humanity from 'climate change'. Schwab said: 'The pandemic represents a rare but narrow window of opportunity to reflect, reimagine, and reset our world.' What he didn't mention is that the Cult he serves is behind both hoaxes as I show in my book *The Answer*. He and the Cult don't have to reimagine the world. They know precisely what they want and that's why they destroyed human society with 'Covid' to 'build back better' in their grand design. Their job is not to imagine, but to get humanity to imagine and agree with their plans while believing it's all random. It must be pure coincidence that 'The Great Reset' has long been the Cult's code name for the global imposition of fascism and replaced previous code-names of the 'New World

Order' used by Cult frontmen like Father George Bush and the 'New Order of the Ages' which emerged from Freemasonry and much older secret societies. New Order of the Ages appears on the reverse of the Great Seal of the United States as 'Novus ordo seclorum' underneath the Cult symbol used since way back of the pyramid and all seeing-eye (Fig 3). The pyramid is the hierarchy of human control headed by the illuminated eye that symbolises the force behind the Cult which I will expose in later chapters. The term 'Annuet Coeptis' translates as 'He favours our undertaking'. We are told the 'He' is the Christian god, but 'He' is not as I will be explaining.



**Figure 3:** The all-seeing eye of the Cult 'god' on the Freemason-designed Great Seal of the United States and also on the dollar bill.

## **Having you on**

Two major Cult techniques of perceptual manipulation that relate to all this are what I have called since the 1990s Problem-Reaction-Solution (PRS) and the Totalitarian Tiptoe (TT). They can be uncovered by the inquiring mind with a simple question: Who benefits? The answer usually identifies the perpetrators of a given action or happening through the concept of 'he who most benefits from a crime is the one most likely to have committed it'. The Latin 'Cue bono?' – Who benefits? – is widely attributed to the Roman orator and statesman Marcus Tullius Cicero. No wonder it goes back so far when the concept has been relevant to human behaviour since

history was recorded. Problem-Reaction-Solution is the technique used to manipulate us every day by covertly creating a problem (or the illusion of one) and offering the solution to the problem (or the illusion of one). In the first phase you create the problem and blame someone or something else for why it has happened. This may relate to a financial collapse, terrorist attack, war, global warming or pandemic, anything in fact that will allow you to impose the 'solution' to change society in the way you desire at that time. The 'problem' doesn't have to be real. PRS is manipulation of perception and all you need is the population to believe the problem is real. Human-caused global warming and the 'Covid pandemic' only have to be *perceived* to be real for the population to accept the 'solutions' of authority. I refer to this technique as NO-Problem-Reaction-Solution. Billions did not meekly accept house arrest from early 2020 because there was a real deadly 'Covid pandemic' but because they perceived – believed – that to be the case. The antidote to Problem-Reaction-Solution is to ask who benefits from the proposed solution. Invariably it will be anyone who wants to justify more control through deletion of freedom and centralisation of power and decision-making.

The two world wars were Problem-Reaction-Solutions that transformed and realigned global society. Both were manipulated into being by the Cult as I have detailed in books since the mid-1990s. They dramatically centralised global power, especially World War Two, which led to the United Nations and other global bodies thanks to the overt and covert manipulations of the Rockefeller family and other Cult bloodlines like the Rothschilds. The UN is a stalking horse for full-blown world government that I will come to shortly. The land on which the UN building stands in New York was donated by the Rockefellers and the same Cult family was behind Big Pharma scalpel and drug 'medicine' and the creation of the World Health Organization as part of the UN. They have been stalwarts of the eugenics movement and funded Hitler's race-purity expert' Ernst Rudin. The human-caused global warming hoax has been orchestrated by the Club of Rome through the UN which is

manufacturing both the 'problem' through its Intergovernmental Panel on Climate Change and imposing the 'solution' through its Agenda 21 and Agenda 2030 which demand the total centralisation of global power to 'save the world' from a climate hoax the United Nations is itself perpetrating. What a small world the Cult can be seen to be particularly among the inner circles. The bedfellow of Problem-Reaction-Solution is the Totalitarian Tiptoe which became the Totalitarian Sprint in 2020. The technique is fashioned to hide the carefully-coordinated behind the cover of apparently random events. You start the sequence at 'A' and you know you are heading for 'Z'. You don't want people to know that and each step on the journey is presented as a random happening while all the steps strung together lead in the same direction. The speed may have quickened dramatically in recent times, but you can still see the incremental approach of the Tiptoe in the case of 'Covid' as each new imposition takes us deeper into fascism. Tell people they have to do this or that to get back to 'normal', then this and this and this. With each new demand adding to the ones that went before the population's freedom is deleted until it disappears. The spider wraps its web around the flies more comprehensively with each new diktat. I'll highlight this in more detail when I get to the 'Covid' hoax and how it has been pulled off. Another prime example of the Totalitarian Tiptoe is how the Cult-created European Union went from a 'free-trade zone' to a centralised bureaucratic dictatorship through the Tiptoe of incremental centralisation of power until nations became mere administrative units for Cult-owned dark suits in Brussels.

The antidote to ignorance is knowledge which the Cult seeks vehemently to deny us, but despite the systematic censorship to that end the Renegade Mind can overcome this by vociferously seeking out the facts no matter the impediments put in the way. There is also a method of thinking and perceiving – *knowing* – that doesn't even need names, dates, place-type facts to identify the patterns that reveal the story. I'll get to that in the final chapter. All you need to know about the manipulation of human society and to what end is still out there – *at the time of writing* – in the form of books, videos



and websites for those that really want to breach the walls of programmed perception. To access this knowledge requires the abandonment of the mainstream media as a source of information in the awareness that this is owned and controlled by the Cult and therefore promotes mass perceptions that suit the Cult. Mainstream media lies all day, every day. That is its function and very reason for being. Where it does tell the truth, here and there, is only because the truth and the Cult agenda very occasionally coincide. If you look for fact and insight to the BBC, CNN and virtually all the rest of them you are asking to be conned and perceptually programmed.

### **Know the outcome and you'll see the journey**

Events seem random when you have no idea where the world is being taken. Once you do the random becomes the carefully planned. Know the outcome and you'll see the journey is a phrase I have been using for a long time to give context to daily happenings that appear unconnected. Does a problem, or illusion of a problem, trigger a proposed 'solution' that further drives society in the direction of the outcome? Invariably the answer will be yes and the random – *abracadabra* – becomes the clearly coordinated. So what is this outcome that unlocks the door to a massively expanded understanding of daily events? I will summarise its major aspects – the fine detail is in my other books – and those new to this information will see that the world they thought they were living in is a very different place. The foundation of the Cult agenda is the incessant centralisation of power and all such centralisation is ultimately in pursuit of Cult control on a global level. I have described for a long time the planned world structure of top-down dictatorship as the Hunger Games Society. The term obviously comes from the movie series which portrayed a world in which a few living in military-protected hi-tech luxury were the overlords of a population condemned to abject poverty in isolated 'sectors' that were not allowed to interact. 'Covid' lockdowns and travel bans anyone? The 'Hunger Games' pyramid of structural control has the inner circle of the Cult at the top with pretty much the entire

population at the bottom under their control through dependency for survival on the Cult. The whole structure is planned to be protected and enforced by a military-police state (Fig 4).

Here you have the reason for the global lockdowns of the fake pandemic to coldly destroy independent incomes and livelihoods and make everyone dependent on the 'state' (the Cult that controls the 'states'). I have warned in my books for many years about the plan to introduce a 'guaranteed income' – a barely survivable pittance – designed to impose dependency when employment was destroyed by AI technology and now even more comprehensively at great speed by the 'Covid' scam. Once the pandemic was played and lockdown consequences began to delete independent income the authorities began to talk right on cue about the need for a guaranteed income and a 'Great Reset'. Guaranteed income will be presented as benevolent governments seeking to help a desperate people – desperate as a direct result of actions of the same governments. The truth is that such payments are a trap. You will only get them if you do exactly what the authorities demand including mass vaccination (genetic manipulation). We have seen this theme already in Australia where those dependent on government benefits have them reduced if parents don't agree to have their children vaccinated according to an insane health-destroying government-dictated schedule. Calculated economic collapse applies to governments as well as people. The Cult wants rid of countries through the creation of a world state with countries broken up into regions ruled by a world government and super states like the European Union. Countries must be bankrupted, too, to this end and it's being achieved by the trillions in 'rescue packages' and furlough payments, trillions in lost taxation, and money-no-object spending on 'Covid' including constant all-medium advertising (programming) which has made the media dependent on government for much of its income. The day of reckoning is coming – as planned – for government spending and given that it has been made possible by printing money and not by production/taxation there is inflation on the way that has the

potential to wipe out monetary value. In that case there will be no need for the Cult to steal your money. It just won't be worth anything (see the German Weimar Republic before the Nazis took over). Many have been okay with lockdowns while getting a percentage of their income from so-called furlough payments without having to work. Those payments are dependent, however, on people having at least a theoretical job with a business considered non-essential and ordered to close. As these business go under because they are closed by lockdown after lockdown the furlough stops and it will for everyone eventually. Then what? The 'then what?' is precisely the idea.



**Figure 4:** The Hunger Games Society structure I have long warned was planned and now the 'Covid' hoax has made it possible. This is the real reason for lockdowns.

## **Hired hands**

Between the Hunger Games Cult elite and the dependent population is planned to be a vicious military-police state (a fusion of the two into one force). This has been in the making for a long time with police looking ever more like the military and carrying weapons to match. The pandemic scam has seen this process accelerate so fast as

lockdown house arrest is brutally enforced by carefully recruited fascist minds and gormless system-servers. The police and military are planned to merge into a centrally-directed world army in a global structure headed by a world government which wouldn't be elected even by the election fixes now in place. The world army is not planned even to be human and instead wars would be fought, primarily against the population, using robot technology controlled by artificial intelligence. I have been warning about this for decades and now militaries around the world are being transformed by this very AI technology. The global regime that I describe is a particular form of fascism known as a technocracy in which decisions are not made by clueless and co-opted politicians but by unelected technocrats – scientists, engineers, technologists and bureaucrats. Cult-owned-and-controlled Silicon Valley giants are examples of technocracy and they already have far more power to direct world events than governments. They are with their censorship *selecting* governments. I know that some are calling the 'Great Reset' a Marxist communist takeover, but fascism and Marxism are different labels for the same tyranny. Tell those who lived in fascist Germany and Stalinist Russia that there was a difference in the way their freedom was deleted and their lives controlled. I could call it a fascist technocracy or a Marxist technocracy and they would be equally accurate. The Hunger Games society with its world government structure would oversee a world army, world central bank and single world cashless currency imposing its will on a microchipped population (Fig 5). Scan its different elements and see how the illusory pandemic is forcing society in this very direction at great speed. Leaders of 23 countries and the World Health Organization (WHO) backed the idea in March, 2021, of a global treaty for 'international cooperation' in 'health emergencies' and nations should 'come together as a global community for peaceful cooperation that extends beyond this crisis'. Cut the Orwellian bullshit and this means another step towards global government. The plan includes a cashless digital money system that I first warned about in 1993. Right at the start of 'Covid' the deeply corrupt Tedros

Adhanom Ghebreyesus, the crooked and merely gofer 'head' of the World Health Organization, said it was possible to catch the 'virus' by touching cash and it was better to use cashless means. The claim was ridiculous nonsense and like the whole 'Covid' mind-trick it was nothing to do with 'health' and everything to do with pushing every aspect of the Cult agenda. As a result of the Tedros lie the use of cash has plummeted. The Cult script involves a single world digital currency that would eventually be technologically embedded in the body. China is a massive global centre for the Cult and if you watch what is happening there you will know what is planned for everywhere. The Chinese government is developing a digital currency which would allow fines to be deducted immediately via AI for anyone caught on camera breaking its fantastic list of laws and the money is going to be programmable with an expiry date to ensure that no one can accrue wealth except the Cult and its operatives.



**Figure 5:** The structure of global control the Cult has been working towards for so long and this has been enormously advanced by the 'Covid' illusion.

## **Serfdom is so smart**

The Cult plan is far wider, extreme, and more comprehensive than even most conspiracy researchers appreciate and I will come to the true depths of deceit and control in the chapters 'Who controls the

Cult?’ and ‘Escaping Wetiko’. Even the world that we know is crazy enough. We are being deluged with ever more sophisticated and controlling technology under the heading of ‘smart’. We have smart televisions, smart meters, smart cards, smart cars, smart driving, smart roads, smart pills, smart patches, smart watches, smart skin, smart borders, smart pavements, smart streets, smart cities, smart communities, smart environments, smart growth, smart planet ... smart *everything* around us. Smart technologies and methods of operation are designed to interlock to create a global Smart Grid connecting the entirety of human society including human minds to create a centrally-dictated ‘hive’ mind. ‘Smart cities’ is code for densely-occupied megacities of total surveillance and control through AI. Ever more destructive frequency communication systems like 5G have been rolled out without any official testing for health and psychological effects (colossal). 5G/6G/7G systems are needed to run the Smart Grid and each one becomes more destructive of body and mind. Deleting independent income is crucial to forcing people into these AI-policed prisons by ending private property ownership (except for the Cult elite). The Cult’s Great Reset now openly foresees a global society in which no one will own any possessions and everything will be rented while the Cult would own literally everything under the guise of government and corporations. The aim has been to use the lockdowns to destroy sources of income on a mass scale and when the people are destitute and in unrepayable amounts of debt (problem) Cult assets come forward with the pledge to write-off debt in return for handing over all property and possessions (solution). Everything – literally everything including people – would be connected to the Internet via AI. I was warning years ago about the coming Internet of Things (IoT) in which all devices and technology from your car to your fridge would be plugged into the Internet and controlled by AI. Now we are already there with much more to come. The next stage is the Internet of Everything (IoE) which is planned to include the connection of AI to the human brain and body to replace the human mind with a centrally-controlled AI mind. Instead of perceptions

being manipulated through control of information and censorship those perceptions would come direct from the Cult through AI. What do you think? You think whatever AI decides that you think. In human terms there would be no individual 'think' any longer. Too incredible? The ravings of a lunatic? Not at all. Cult-owned crazies in Silicon Valley have been telling us the plan for years without explaining the real motivation and calculated implications. These include Google executive and 'futurist' Ray Kurzweil who highlights the year 2030 for when this would be underway. He said:

Our thinking ... will be a hybrid of biological and non-biological thinking ... humans will be able to extend their limitations and 'think in the cloud' ... We're going to put gateways to the cloud in our brains ... We're going to gradually merge and enhance ourselves ... In my view, that's the nature of being human – we transcend our limitations.

As the technology becomes vastly superior to what we are then the small proportion that is still human gets smaller and smaller and smaller until it's just utterly negligible.

The sales-pitch of Kurzweil and Cult-owned Silicon Valley is that this would make us 'super-human' when the real aim is to make us post-human and no longer 'human' in the sense that we have come to know. The entire global population would be connected to AI and become the centrally-controlled 'hive-mind' of externally-delivered perceptions. The Smart Grid being installed to impose the Cult's will on the world is being constructed to allow particular locations – even one location – to control the whole global system. From these prime control centres, which absolutely include China and Israel, anything connected to the Internet would be switched on or off and manipulated at will. Energy systems could be cut, communication via the Internet taken down, computer-controlled driverless autonomous vehicles driven off the road, medical devices switched off, the potential is limitless given how much AI and Internet connections now run human society. We have seen nothing yet if we allow this to continue. Autonomous vehicle makers are working with law enforcement to produce cars designed to automatically pull over if they detect a police or emergency vehicle flashing from up to 100 feet away. At a police stop the car would be unlocked and the

window rolled down automatically. Vehicles would only take you where the computer (the state) allowed. The end of petrol vehicles and speed limiters on all new cars in the UK and EU from 2022 are steps leading to electric computerised transport over which ultimately you have no control. The picture is far bigger even than the Cult global network or web and that will become clear when I get to the nature of the 'spider'. There is a connection between all these happenings and the instigation of DNA-manipulating 'vaccines' (which aren't 'vaccines') justified by the 'Covid' hoax. That connection is the unfolding plan to transform the human body from a biological to a synthetic biological state and this is why synthetic biology is such a fast-emerging discipline of mainstream science. 'Covid vaccines' are infusing self-replicating synthetic genetic material into the cells to cumulatively take us on the Totalitarian Tiptoe from Human 1.0 to the synthetic biological Human 2.0 which will be physically and perceptually attached to the Smart Grid to one hundred percent control every thought, perception and deed. Humanity needs to wake up and *fast*.

This is the barest explanation of where the 'outcome' is planned to go but it's enough to see the journey happening all around us. Those new to this information will already see 'Covid' in a whole new context. I will add much more detail as we go along, but for the minutiae evidence see my mega-works, *The Answer*, *The Trigger* and *Everything You Need to Know But Have Never Been Told*.

Now – how does a Renegade Mind see the 'world'?



## CHAPTER TWO

# Renegade Perception

*It is one thing to be clever and another to be wise*

George R.R. Martin

A simple definition of the difference between a programmed mind and a Renegade Mind would be that one sees only dots while the other connects them to see the picture. Reading reality with accuracy requires the observer to (a) know the planned outcome and (b) realise that everything, but *everything*, is connected.

The entirety of infinite reality is connected – that’s its very nature – and with human society an expression of infinite reality the same must apply. Simple cause and effect is a connection. The effect is triggered by the cause and the effect then becomes the cause of another effect. Nothing happens in isolation because it *can’t*. Life in whatever reality is simple choice and consequence. We make choices and these lead to consequences. If we don’t like the consequences we can make different choices and get different consequences which lead to other choices and consequences. The choice and the consequence are not only connected they are indivisible. You can’t have one without the other as an old song goes. A few cannot control the world unless those being controlled allow that to happen – cause and effect, choice and consequence. Control – who has it and who doesn’t – is a two-way process, a symbiotic relationship, involving the controller and controlled. ‘They took my freedom away!!’ Well, yes, but you also gave it to them. Humanity is

subjected to mass control because humanity has acquiesced to that control. This is all cause and effect and literally a case of give and take. In the same way world events of every kind are connected and the Cult works incessantly to sell the illusion of the random and coincidental to maintain the essential (to them) perception of dots that hide the picture. Renegade Minds know this and constantly scan the world for patterns of connection. This is absolutely pivotal in understanding the happenings in the world and without that perspective clarity is impossible. First you know the planned outcome and then you identify the steps on the journey – the day-by-day apparently random which, when connected in relation to the outcome, no longer appear as individual events, but as the proverbial *chain* of events leading in the same direction. I'll give you some examples:

### **Political puppet show**

We are told to believe that politics is 'adversarial' in that different parties with different beliefs engage in an endless tussle for power. There may have been some truth in that up to a point – and only a point – but today divisions between 'different' parties are rhetorical not ideological. Even the rhetorical is fusing into one-speak as the parties eject any remaining free thinkers while others succumb to the ever-gathering intimidation of anyone with the 'wrong' opinion. The Cult is not a new phenomenon and can be traced back thousands of years as my books have documented. Its intergenerational initiatives have been manipulating events with increasing effect the more that global power has been centralised. In ancient times the Cult secured control through the system of monarchy in which 'special' bloodlines (of which more later) demanded the right to rule as kings and queens simply by birthright and by vanquishing others who claimed the same birthright. There came a time, however, when people had matured enough to see the unfairness of such tyranny and demanded a say in who governed them. Note the word – *governed* them. Not served them – *governed* them, hence government defined as 'the political direction and control exercised over the

actions of the members, citizens, or inhabitants of communities, societies, and states; direction of the affairs of a state, community, etc.' Governments exercise control over rather than serve just like the monarchies before them. Bizarrely there are still countries like the United Kingdom which are ruled by a monarch *and* a government that officially answers to the monarch. The UK head of state and that of Commonwealth countries such as Canada, Australia and New Zealand is 'selected' by who in a *single family* had unprotected sex with whom and in what order. Pinch me it can't be true. Ouch! Shit, it is. The demise of monarchies in most countries offered a potential vacuum in which some form of free and fair society could arise and the Cult had that base covered. Monarchies had served its interests but they couldn't continue in the face of such widespread opposition and, anyway, replacing a 'royal' dictatorship that people could see with a dictatorship 'of the people' hiding behind the concept of 'democracy' presented far greater manipulative possibilities and ways of hiding coordinated tyranny behind the illusion of 'freedom'.

Democracy is quite wrongly defined as government selected by the population. This is not the case at all. It is government selected by *some* of the population (and then only in theory). This 'some' doesn't even have to be the majority as we have seen so often in first-past-the-post elections in which the so-called majority party wins fewer votes than the 'losing' parties combined. Democracy can give total power to a party in government from a minority of the votes cast. It's a sleight of hand to sell tyranny as freedom. Seventy-four million Trump-supporting Americans didn't vote for the 'Democratic' Party of Joe Biden in the distinctly dodgy election in 2020 and yet far from acknowledging the wishes and feelings of that great percentage of American society the Cult-owned Biden government set out from day one to destroy them and their right to a voice and opinion. Empty shell Biden and his Cult handlers said they were doing this to 'protect democracy'. Such is the level of lunacy and sickness to which politics has descended. Connect the dots and relate them to the desired outcome – a world government run by self-appointed technocrats and no longer even elected

politicians. While operating through its political agents in government the Cult is at the same time encouraging public disdain for politicians by putting idiots and incompetents in theoretical power on the road to deleting them. The idea is to instil a public reaction that says of the technocrats: 'Well, they couldn't do any worse than the pathetic politicians.' It's all about controlling perception and Renegade Minds can see through that while programmed minds cannot when they are ignorant of both the planned outcome and the manipulation techniques employed to secure that end. This knowledge can be learned, however, and fast if people choose to get informed.

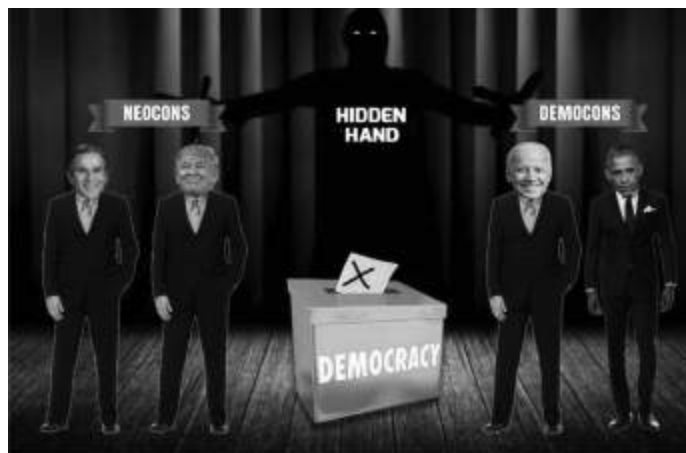
Politics may at first sight appear very difficult to control from a central point. I mean look at the 'different' parties and how would you be able to oversee them all and their constituent parts? In truth, it's very straightforward because of their structure. We are back to the pyramid of imposition and acquiescence. Organisations are structured in the same way as the system as a whole. Political parties are not open forums of free expression. They are hierarchies. I was a national spokesman for the British Green Party which claimed to be a different kind of politics in which influence and power was devolved; but I can tell you from direct experience – and it's far worse now – that Green parties are run as hierarchies like all the others however much they may try to hide that fact or kid themselves that it's not true. A very few at the top of all political parties are directing policy and personnel. They decide if you are elevated in the party or serve as a government minister and to do that you have to be a yes man or woman. Look at all the maverick political thinkers who never ascended the greasy pole. If you want to progress within the party or reach 'high-office' you need to fall into line and conform. Exceptions to this are rare indeed. Should you want to run for parliament or Congress you have to persuade the local or state level of the party to select you and for that you need to play the game as dictated by the hierarchy. If you secure election and wish to progress within the greater structure you need to go on conforming to what is acceptable to those running the hierarchy

from the peak of the pyramid. Political parties are perceptual gulags and the very fact that there are party 'Whips' appointed to 'whip' politicians into voting the way the hierarchy demands exposes the ridiculous idea that politicians are elected to serve the people they are supposed to represent. Cult operatives and manipulation has long seized control of major parties that have any chance of forming a government and at least most of those that haven't. A new party forms and the Cult goes to work to infiltrate and direct. This has reached such a level today that you see video compilations of 'leaders' of all parties whether Democrats, Republicans, Conservative, Labour and Green parroting the same Cult mantra of 'Build Back Better' and the 'Great Reset' which are straight off the Cult song-sheet to describe the transformation of global society in response to the Cult-instigated hoaxes of the 'Covid pandemic' and human-caused 'climate change'. To see Caroline Lucas, the Green Party MP that I knew when I was in the party in the 1980s, speaking in support of plans proposed by Cult operative Klaus Schwab representing the billionaire global elite is a real head-shaker.

### **Many parties – one master**

The party system is another mind-trick and was instigated to change the nature of the dictatorship by swapping 'royalty' for dark suits that people believed – though now ever less so – represented their interests. Understanding this trick is to realise that a single force (the Cult) controls all parties either directly in terms of the major ones or through manipulation of perception and ideology with others. You don't need to manipulate Green parties to demand your transformation of society in the name of 'climate change' when they are obsessed with the lie that this is essential to 'save the planet'. You just give them a platform and away they go serving your interests while believing they are being environmentally virtuous. America's political structure is a perfect blueprint for how the two or multi-party system is really a one-party state. The Republican Party is controlled from one step back in the shadows by a group made up of billionaires and their gofers known as neoconservatives or Neocons.

I have exposed them in fine detail in my books and they were the driving force behind the policies of the imbecilic presidency of Boy George Bush which included 9/11 (see *The Trigger* for a comprehensive demolition of the official story), the subsequent 'war on terror' (war of terror) and the invasions of Afghanistan and Iraq. The latter was a No-Problem-Reaction-Solution based on claims by Cult operatives, including Bush and British Prime Minister Tony Blair, about Saddam Hussein's 'weapons of mass destruction' which did not exist as war criminals Bush and Blair well knew.



**Figure 6:** Different front people, different parties – same control system.

The Democratic Party has its own 'Neocon' group controlling from the background which I call the 'Democons' and here's the penny-drop – the Neocons and Democons answer to the same masters one step further back into the shadows (Fig 6). At that level of the Cult the Republican and Democrat parties are controlled by the same people and no matter which is in power the Cult is in power. This is how it works in almost every country and certainly in Britain with Conservative, Labour, Liberal Democrat and Green parties now all on the same page whatever the rhetoric may be in their feeble attempts to appear different. Neocons operated at the time of Bush through a think tank called The Project for the New American Century which in September, 2000, published a document entitled *Rebuilding America's Defenses: Strategies, Forces, and Resources*

*For a New Century* demanding that America fight ‘multiple, simultaneous major theatre wars’ as a ‘core mission’ to force regime-change in countries including Iraq, Libya and Syria. Neocons arranged for Bush (‘Republican’) and Blair (‘Labour Party’) to front-up the invasion of Iraq and when they departed the Democons orchestrated the targeting of Libya and Syria through Barack Obama (‘Democrat’) and British Prime Minister David Cameron (‘Conservative Party’). We have ‘different’ parties and ‘different’ people, but the same unfolding script. The more the Cult has seized the reigns of parties and personnel the more their policies have transparently pursued the same agenda to the point where the fascist ‘Covid’ impositions of the Conservative junta of Jackboot Johnson in Britain were opposed by the Labour Party because they were not fascist enough. The Labour Party is likened to the US Democrats while the Conservative Party is akin to a British version of the Republicans and on both sides of the Atlantic they all speak the same language and support the direction demanded by the Cult although some more enthusiastically than others. It’s a similar story in country after country because it’s all centrally controlled. Oh, but what about Trump? I’ll come to him shortly. Political ‘choice’ in the ‘party’ system goes like this: You vote for Party A and they get into government. You don’t like what they do so next time you vote for Party B and they get into government. You don’t like what they do when it’s pretty much the same as Party A and why wouldn’t that be with both controlled by the same force? Given that only two, sometimes three, parties have any chance of forming a government to get rid of Party B that you don’t like you have to vote again for Party A which ... you don’t like. This, ladies and gentlemen, is what they call ‘democracy’ which we are told – wrongly – is a term interchangeable with ‘freedom’.

## **The cult of cults**

At this point I need to introduce a major expression of the Global Cult known as Sabbatian-Frankism. Sabbatian is also spelt as Sabbatean. I will summarise here. I have published major exposés

and detailed background in other works. Sabbatian-Frankism combines the names of two frauds posing as 'Jewish' men, Sabbatai Zevi (1626-1676), a rabbi, black magician and occultist who proclaimed he was the Jewish messiah; and Jacob Frank (1726-1791), the Polish 'Jew', black magician and occultist who said he was the reincarnation of 'messiah' Zevi and biblical patriarch Jacob. They worked across two centuries to establish the Sabbatian-Frankist cult that plays a major, indeed central, role in the manipulation of human society by the Global Cult which has its origins much further back in history than Sabbatai Zevi. I should emphasise two points here in response to the shrill voices that will scream 'anti-Semitism': (1) Sabbatian-Frankists are NOT Jewish and only pose as such to hide their cult behind a Jewish façade; and (2) my information about this cult has come from Jewish sources who have long realised that their society and community has been infiltrated and taken over by interloper Sabbatian-Frankists. Infiltration has been the foundation technique of Sabbatian-Frankism from its official origin in the 17th century. Zevi's Sabbatian sect attracted a massive following described as the biggest messianic movement in Jewish history, spreading as far as Africa and Asia, and he promised a return for the Jews to the 'Promised Land' of Israel. Sabbatianism was not Judaism but an inversion of everything that mainstream Judaism stood for. So much so that this sinister cult would have a feast day when Judaism had a fast day and whatever was forbidden in Judaism the Sabbatians were encouraged and even commanded to do. This included incest and what would be today called Satanism. Members were forbidden to marry outside the sect and there was a system of keeping their children ignorant of what they were part of until they were old enough to be trusted not to unknowingly reveal anything to outsiders. The same system is employed to this day by the Global Cult in general which Sabbatian-Frankism has enormously influenced and now largely controls.

Zevi and his Sabbatians suffered a setback with the intervention by the Sultan of the Islamic Ottoman Empire in the Middle East and what is now the Republic of Turkey where Zevi was located. The



Sultan gave him the choice of proving his 'divinity', converting to Islam or facing torture and death. Funnily enough Zevi chose to convert or at least appear to. Some of his supporters were disillusioned and drifted away, but many did not with 300 families also converting – only in theory – to Islam. They continued behind this Islamic smokescreen to follow the goals, rules and rituals of Sabbatianism and became known as 'crypto-Jews' or the 'Dönme' which means 'to turn'. This is rather ironic because they didn't 'turn' and instead hid behind a fake Islamic persona. The process of appearing to be one thing while being very much another would become the calling card of Sabbatianism especially after Zevi's death and the arrival of the Satanist Jacob Frank in the 18th century when the cult became Sabbatian-Frankism and plumbed still new depths of depravity and infiltration which included – still includes – human sacrifice and sex with children. Wherever Sabbatians go paedophilia and Satanism follow and is it really a surprise that Hollywood is so infested with child abuse and Satanism when it was established by Sabbatian-Frankists and is still controlled by them? Hollywood has been one of the prime vehicles for global perceptual programming and manipulation. How many believe the version of 'history' portrayed in movies when it is a travesty and inversion (again) of the truth? Rabbi Marvin Antelman describes Frankism in his book, *To Eliminate the Opiate*, as 'a movement of complete evil' while Jewish professor Gershom Scholem said of Frank in *The Messianic Idea in Judaism*: 'In all his actions [he was] a truly corrupt and degenerate individual ... one of the most frightening phenomena in the whole of Jewish history.' Frank was excommunicated by traditional rabbis, as was Zevi, but Frank was undeterred and enjoyed vital support from the House of Rothschild, the infamous banking dynasty whose inner-core are Sabbatian-Frankists and not Jews. Infiltration of the Roman Church and Vatican was instigated by Frank with many Dönme 'turning' again to convert to Roman Catholicism with a view to hijacking the reins of power. This was the ever-repeating modus operandi and continues to be so. Pose as an advocate of the religion, culture or country that you want to control and then

manipulate your people into the positions of authority and influence largely as advisers, administrators and Svengalis for those that appear to be in power. They did this with Judaism, Christianity (Christian Zionism is part of this), Islam and other religions and nations until Sabbatian-Frankism spanned the world as it does today.

### **Sabbatian Saudis and the terror network**

One expression of the Sabbatian-Frankist Dönme within Islam is the ruling family of Saudi Arabia, the House of Saud, through which came the vile distortion of Islam known as Wahhabism. This is the violent creed followed by terrorist groups like Al-Qaeda and ISIS or Islamic State. Wahhabism is the hand-chopping, head-chopping 'religion' of Saudi Arabia which is used to keep the people in a constant state of fear so the interloper House of Saud can continue to rule. Al-Qaeda and Islamic State were lavishly funded by the House of Saud while being created and directed by the Sabbatian-Frankist network in the United States that operates through the Pentagon, CIA and the government in general of whichever 'party'. The front man for the establishment of Wahhabism in the middle of the 18th century was a Sabbatian-Frankist 'crypto-Jew' posing as Islamic called Muhammad ibn Abd al-Wahhab. His daughter would marry the son of Muhammad bin Saud who established the first Saudi state before his death in 1765 with support from the British Empire. Bin Saud's successors would establish modern Saudi Arabia in league with the British and Americans in 1932 which allowed them to seize control of Islam's major shrines in Mecca and Medina. They have dictated the direction of Sunni Islam ever since while Iran is the major centre of the Shiite version and here we have the source of at least the public conflict between them. The Sabbatian network has used its Wahhabi extremists to carry out Problem-Reaction-Solution terrorist attacks in the name of 'Al-Qaeda' and 'Islamic State' to justify a devastating 'war on terror', ever-increasing surveillance of the population and to terrify people into compliance. Another insight of the Renegade Mind is the streetwise understanding that

just because a country, location or people are attacked doesn't mean that those apparently representing that country, location or people are not behind the attackers. Often they are *orchestrating* the attacks because of the societal changes that can be then justified in the name of 'saving the population from terrorists'.

I show in great detail in *The Trigger* how Sabbatian-Frankists were the real perpetrators of 9/11 and not '19 Arab hijackers' who were blamed for what happened. Observe what was justified in the name of 9/11 alone in terms of Middle East invasions, mass surveillance and control that fulfilled the demands of the Project for the New American Century document published by the Sabbatian Neocons. What appear to be enemies are on the deep inside players on the same Sabbatian team. Israel and Arab 'royal' dictatorships are all ruled by Sabbatians and the recent peace agreements between Israel and Saudi Arabia, the United Arab Emirates (UAE) and others are only making formal what has always been the case behind the scenes. Palestinians who have been subjected to grotesque tyranny since Israel was bombed and terrorised into existence in 1948 have never stood a chance. Sabbatian-Frankists have controlled Israel (so the constant theme of violence and war which Sabbatians love) and they have controlled the Arab countries that Palestinians have looked to for real support that never comes. 'Royal families' of the Arab world in Saudi Arabia, Bahrain, UAE, etc., are all Sabbatians with allegiance to the aims of the cult and not what is best for their Arabic populations. They have stolen the oil and financial resources from their people by false claims to be 'royal dynasties' with a genetic right to rule and by employing vicious militaries to impose their will.

### **Satanic 'illumination'**

The Satanist Jacob Frank formed an alliance in 1773 with two other Sabbatians, Mayer Amschel Rothschild (1744-1812), founder of the Rothschild banking dynasty, and Jesuit-educated fraudulent Jew, Adam Weishaupt, and this led to the formation of the Bavarian Illuminati, firstly under another name, in 1776. The Illuminati would

be the manipulating force behind the French Revolution (1789-1799) and was also involved in the American Revolution (1775-1783) before and after the Illuminati's official creation. Weishaupt would later become (in public) a Protestant Christian in archetypal Sabbatian style. I read that his name can be decoded as Adam-Weishaupt or 'the first man to lead those who know'. He wasn't a leader in the sense that he was a subordinate, but he did lead those below him in a crusade of transforming human society that still continues today. The theme was confirmed as early as 1785 when a horseman courier called Lanz was reported to be struck by lightning and extensive Illuminati documents were found in his saddlebags. They made the link to Weishaupt and detailed the plan for world takeover. Current events with 'Covid' fascism have been in the making for a very long time. Jacob Frank was jailed for 13 years by the Catholic Inquisition after his arrest in 1760 and on his release he headed for Frankfurt, Germany, home city and headquarters of the House of Rothschild where the alliance was struck with Mayer Amschel Rothschild and Weishaupt. Rothschild arranged for Frank to be given the title of Baron and he became a wealthy nobleman with a big following of Jews in Germany, the Austro-Hungarian Empire and other European countries. Most of them would have believed he was on their side.

The name 'Illuminati' came from the Zohar which is a body of works in the Jewish mystical 'bible' called the Kabbalah. 'Zohar' is the foundation of Sabbatian-Frankist belief and in Hebrew 'Zohar' means 'splendour', 'radiance', 'illuminated', and so we have 'Illuminati'. They claim to be the 'Illuminated Ones' from their knowledge systematically hidden from the human population and passed on through generations of carefully-chosen initiates in the global secret society network or Cult. Hidden knowledge includes an awareness of the Cult agenda for the world and the nature of our collective reality that I will explore later. Cult 'illumination' is symbolised by the torch held by the Statue of Liberty which was gifted to New York by French Freemasons in Paris who knew exactly what it represents. 'Liberty' symbolises the goddess worshipped in

Babylon as Queen Semiramis or Ishtar. The significance of this will become clear. Notice again the ubiquitous theme of inversion with the Statue of 'Liberty' really symbolising mass control (Fig 7). A mirror-image statute stands on an island in the River Seine in Paris from where New York Liberty originated (Fig 8). A large replica of the Liberty flame stands on top of the Pont de l'Alma tunnel in Paris where Princess Diana died in a Cult ritual described in *The Biggest Secret*. Lucifer 'the light bringer' is related to all this (and much more as we'll see) and 'Lucifer' is a central figure in Sabbatian-Frankism and its associated Satanism. Sabbatians reject the Jewish Torah, or Pentateuch, the 'five books of Moses' in the Old Testament known as Genesis, Exodus, Leviticus, Numbers, and Deuteronomy which are claimed by Judaism and Christianity to have been dictated by 'God' to Moses on Mount Sinai. Sabbatians say these do not apply to them and they seek to replace them with the Zohar to absorb Judaism and its followers into their inversion which is an expression of a much greater global inversion. They want to delete all religions and force humanity to worship a one-world religion – Sabbatian Satanism that also includes worship of the Earth goddess. Satanic themes are being more and more introduced into mainstream society and while Christianity is currently the foremost target for destruction the others are planned to follow.



**Figure 7:** The Cult goddess of Babylon disguised as the Statue of Liberty holding the flame of Lucifer the 'light bringer'.



**Figure 8:** Liberty's mirror image in Paris where the New York version originated.

## **Marx brothers**

Rabbi Marvin Antelman connects the Illuminati to the Jacobins in *To Eliminate the Opiate* and Jacobins were the force behind the French Revolution. He links both to the Bund der Gerechten, or League of the Just, which was the network that inflicted communism/Marxism on the world. Antelman wrote:

The original inner circle of the Bund der Gerechten consisted of born Catholics, Protestants and Jews [Sabbatian-Frankist infiltrators], and those representatives of respective subdivisions formulated schemes for the ultimate destruction of their faiths. The heretical Catholics laid plans which they felt would take a century or more for the ultimate destruction of the church; the apostate Jews for the ultimate destruction of the Jewish religion.

Sabbatian-created communism connects into this anti-religion agenda in that communism does not allow for the free practice of religion. The Sabbatian 'Bund' became the International Communist Party and Communist League and in 1848 'Marxism' was born with the Communist Manifesto of Sabbatian assets Karl Marx and Friedrich Engels. It is absolutely no coincidence that Marxism, just a different name for fascist and other centrally-controlled tyrannies, is being imposed worldwide as a result of the 'Covid' hoax and nor that Marxist/fascist China was the place where the hoax originated. The reason for this will become very clear in the chapter 'Covid: The calculated catastrophe'. The so-called 'Woke' mentality has hijacked

traditional beliefs of the political left and replaced them with far-right make-believe 'social justice' better known as Marxism. Woke will, however, be swallowed by its own perceived 'revolution' which is really the work of billionaires and billionaire corporations feigning being 'Woke'. Marxism is being touted by Wokers as a replacement for 'capitalism' when we don't have 'capitalism'. We have cartelism in which the market is stitched up by the very Cult billionaires and corporations bankrolling Woke. Billionaires love Marxism which keeps the people in servitude while they control from the top. Terminally naïve Wokers think they are 'changing the world' when it's the Cult that is doing the changing and when they have played their vital part and become surplus to requirements they, too, will be targeted. The Illuminati-Jacobins were behind the period known as 'The Terror' in the French Revolution in 1793 and 1794 when Jacobin Maximillian de Robespierre and his Orwellian 'Committee of Public Safety' killed 17,000 'enemies of the Revolution' who had once been 'friends of the Revolution'. Karl Marx (1818-1883), whose Sabbatian creed of Marxism has cost the lives of at least 100 million people, is a hero once again to Wokers who have been systematically kept ignorant of real history by their 'education' programming. As a result they now promote a Sabbatian 'Marxist' abomination destined at some point to consume them. Rabbi Antelman, who spent decades researching the Sabbatian plot, said of the League of the Just and Karl Marx:

Contrary to popular opinion Karl Marx did not originate the Communist Manifesto. He was paid for his services by the League of the Just, which was known in its country of origin, Germany, as the Bund der Geächteten.

Antelman said the text attributed to Marx was the work of other people and Marx 'was only repeating what others already said'. Marx was 'a hired hack – lackey of the wealthy Illuminists'. Marx famously said that religion was the 'opium of the people' (part of the Sabbatian plan to demonise religion) and Antelman called his books, *To Eliminate the Opiate*. Marx was born Jewish, but his family converted to Christianity (Sabbatian modus operandi) and he

attacked Jews, not least in his book, *A World Without Jews*. In doing so he supported the Sabbatian plan to destroy traditional Jewishness and Judaism which we are clearly seeing today with the vindictive targeting of orthodox Jews by the Sabbatian government of Israel over 'Covid' laws. I don't follow any religion and it has done much damage to the world over centuries and acted as a perceptual straightjacket. Renegade Minds, however, are always asking *why* something is being done. It doesn't matter if they agree or disagree with what is happening – *why* is it happening is the question. The 'why?' can be answered with regard to religion in that religions create interacting communities of believers when the Cult wants to dismantle all discourse, unity and interaction (see 'Covid' lockdowns) and the ultimate goal is to delete all religions for a one-world religion of Cult Satanism worshipping their 'god' of which more later. We see the same 'why?' with gun control in America. I don't have guns and don't want them, but why is the Cult seeking to disarm the population at the same time that law enforcement agencies are armed to their molars and why has every tyrant in history sought to disarm people before launching the final takeover? They include Hitler, Stalin, Pol Pot and Mao who followed confiscation with violent seizing of power. You know it's a Cult agenda by the people who immediately race to the microphones to exploit dead people in multiple shootings. Ultra-Zionist Cult lackey Senator Chuck Schumer was straight on the case after ten people were killed in Boulder, Colorado in March, 2121. Simple rule ... if Schumer wants it the Cult wants it and the same with his ultra-Zionist mate the wild-eyed Senator Adam Schiff. At the same time they were calling for the disarmament of Americans, many of whom live a long way from a police response, Schumer, Schiff and the rest of these pampered clowns were sitting on Capitol Hill behind a razor-wired security fence protected by thousands of armed troops in addition to their own armed bodyguards. Mom and pop in an isolated home? They're just potential mass shooters.

## **Zion Mainframe**



Sabbatian-Frankists and most importantly the Rothschilds were behind the creation of 'Zionism', a political movement that demanded a Jewish homeland in Israel as promised by Sabbatai Zevi. The very symbol of Israel comes from the German meaning of the name Rothschild. Dynasty founder Mayer Amschel Rothschild changed the family name from Bauer to Rothschild, or 'Red-Shield' in German, in deference to the six-pointed 'Star of David' hexagram displayed on the family's home in Frankfurt. The symbol later appeared on the flag of Israel after the Rothschilds were centrally involved in its creation. Hexagrams are not a uniquely Jewish symbol and are widely used in occult ('hidden') networks often as a symbol for Saturn (see my other books for why). Neither are Zionism and Jewishness interchangeable. Zionism is a political movement and philosophy and not a 'race' or a people. Many Jews oppose Zionism and many non-Jews, including US President Joe Biden, call themselves Zionists as does Israel-centric Donald Trump. America's support for the Israel government is pretty much a gimme with ultra-Zionist billionaires and corporations providing fantastic and dominant funding for both political parties. Former Congresswoman Cynthia McKinney has told how she was approached immediately she ran for office to 'sign the pledge' to Israel and confirm that she would always vote in that country's best interests. All American politicians are approached in this way. Anyone who refuses will get no support or funding from the enormous and all-powerful Zionist lobby that includes organisations like mega-lobby group AIPAC, the American Israel Public Affairs Committee. Trump's biggest funder was ultra-Zionist casino and media billionaire Sheldon Adelson while major funders of the Democratic Party include ultra-Zionist George Soros and ultra-Zionist financial and media mogul, Haim Saban. Some may reel back at the suggestion that Soros is an Israel-firster (Sabbatian-controlled Israel-firster), but Renegade Minds watch the actions not the words and everywhere Soros donates his billions the Sabbatian agenda benefits. In the spirit of Sabbatian inversion Soros pledged \$1 billion for a new university network to promote 'liberal values and tackle intolerance'. He made the announcement during his annual speech

at the Cult-owned World Economic Forum in Davos, Switzerland, in January, 2020, after his 'harsh criticism' of 'authoritarian rulers' around the world. You can only laugh at such brazen mendacity. How *he* doesn't laugh is the mystery. Translated from the Orwellian 'liberal values and tackle intolerance' means teaching non-white people to hate white people and for white people to loathe themselves for being born white. The reason for that will become clear.

### **The 'Anti-Semitism' fraud**

Zionists support the Jewish homeland in the land of Palestine which has been the Sabbatian-Rothschild goal for so long, but not for the benefit of Jews. Sabbatians and their global Anti-Semitism Industry have skewed public and political opinion to equate opposing the violent extremes of Zionism to be a blanket attack and condemnation of all Jewish people. Sabbatians and their global Anti-Semitism Industry have skewed public and political opinion to equate opposing the violent extremes of Zionism to be a blanket attack and condemnation of all Jewish people. This is nothing more than a Sabbatian protection racket to stop legitimate investigation and exposure of their agendas and activities. The official definition of 'anti-Semitism' has more recently been expanded to include criticism of Zionism – a *political movement* – and this was done to further stop exposure of Sabbatian infiltrators who created Zionism as we know it today in the 19th century. Renegade Minds will talk about these subjects when they know the shit that will come their way. People must decide if they want to know the truth or just cower in the corner in fear of what others will say. Sabbatians have been trying to label me as 'anti-Semitic' since the 1990s as I have uncovered more and more about their background and agendas. Useless, gutless, fraudulent 'journalists' then just repeat the smears without question and on the day I was writing this section a pair of unquestioning repeaters called Ben Quinn and Archie Bland (how appropriate) outright called me an 'anti-Semite' in the establishment propaganda sheet, the London *Guardian*, with no supporting evidence. The

Sabbatian Anti-Semitism Industry said so and who are they to question that? They wouldn't dare. Ironically 'Semitic' refers to a group of languages in the Middle East that are almost entirely Arabic. 'Anti-Semitism' becomes 'anti-Arab' which if the consequences of this misunderstanding were not so grave would be hilarious. Don't bother telling Quinn and Bland. I don't want to confuse them, bless 'em. One reason I am dubbed 'anti-Semitic' is that I wrote in the 1990s that Jewish operatives (Sabbatians) were heavily involved in the Russian Revolution when Sabbatians overthrew the Romanov dynasty. This apparently made me 'anti-Semitic'. Oh, really? Here is a section from *The Trigger*:

British journalist Robert Wilton confirmed these themes in his 1920 book *The Last Days of the Romanovs* when he studied official documents from the Russian government to identify the members of the Bolshevik ruling elite between 1917 and 1919. The Central Committee included 41 Jews among 62 members; the Council of the People's Commissars had 17 Jews out of 22 members; and 458 of the 556 most important Bolshevik positions between 1918 and 1919 were occupied by Jewish people. Only 17 were Russian. Then there were the 23 Jews among the 36 members of the vicious Cheka Soviet secret police established in 1917 who would soon appear all across the country.

Professor Robert Service of Oxford University, an expert on 20th century Russian history, found evidence that ['Jewish'] Leon Trotsky had sought to make sure that Jews were enrolled in the Red Army and were disproportionately represented in the Soviet civil bureaucracy that included the Cheka which performed mass arrests, imprisonment and executions of 'enemies of the people'. A US State Department Decimal File (861.00/5339) dated November 13th, 1918, names [Rothschild banking agent in America] Jacob Schiff and a list of ultra-Zionists as funders of the Russian Revolution leading to claims of a 'Jewish plot', but the key point missed by all is they were not 'Jews' – they were Sabbatian-Frankists.

Britain's Winston Churchill made the same error by mistake or otherwise. He wrote in a 1920 edition of the *Illustrated Sunday Herald* that those behind the Russian revolution were part of a 'worldwide conspiracy for the overthrow of civilisation and for the reconstitution of society on the basis of arrested development, of envious malevolence, and impossible equality' (see 'Woke' today because that has been created by the same network). Churchill said there was no need to exaggerate the part played in the creation of Bolshevism and in the actual bringing about of the Russian

Revolution 'by these international and for the most part atheistical Jews' ['atheistical Jews' = Sabbatians]. Churchill said it is certainly a very great one and probably outweighs all others: 'With the notable exception of Lenin, the majority of the leading figures are Jews.' He went on to describe, knowingly or not, the Sabbatian modus operandi of placing puppet leaders nominally in power while they control from the background:

Moreover, the principal inspiration and driving power comes from the Jewish leaders. Thus Tchitcherin, a pure Russian, is eclipsed by his nominal subordinate, Litvinoff, and the influence of Russians like Bukharin or Lunacharski cannot be compared with the power of Trotsky, or of Zinovieff, the Dictator of the Red Citadel (Petrograd), or of Krassin or Radek – all Jews. In the Soviet institutions the predominance of Jews is even more astonishing. And the prominent, if not indeed the principal, part in the system of terrorism applied by the Extraordinary Commissions for Combatting Counter-Revolution has been taken by Jews, and in some notable cases by Jewesses.

What I said about seriously disproportionate involvement in the Russian Revolution by Jewish 'revolutionaries' (Sabbatians) is provable fact, but truth is no defence against the Sabbatian Anti-Semitism Industry, its repeater parrots like Quinn and Bland, and the now breathtaking network of so-called 'Woke' 'anti-hate' groups with interlocking leaderships and funding which have the role of discrediting and silencing anyone who gets too close to exposing the Sabbatians. We have seen 'truth is no defence' confirmed in legal judgements with the Saskatchewan Human Rights Commission in Canada decreeing this: 'Truthful statements can be presented in a manner that would meet the definition of hate speech, and not all truthful statements must be free from restriction.' Most 'anti-hate' activists, who are themselves consumed by hatred, are too stupid and ignorant of the world to know how they are being used. They are far too far up their own virtue-signalling arses and it's far too dark for them to see anything.

## **The 'revolution' game**

The background and methods of the 'Russian' Revolution are straight from the Sabbatian playbook seen in the French Revolution

and endless others around the world that appear to start as a revolution of the people against tyrannical rule and end up with a regime change to more tyrannical rule overtly or covertly. Wars, terror attacks and regime overthrows follow the Sabbatian cult through history with its agents creating them as Problem-Reaction-Solutions to remove opposition on the road to world domination. Sabbatian dots connect the Rothschilds with the Illuminati, Jacobins of the French Revolution, the 'Bund' or League of the Just, the International Communist Party, Communist League and the Communist Manifesto of Karl Marx and Friedrich Engels that would lead to the Rothschild-funded Russian Revolution. The sequence comes under the heading of 'creative destruction' when you advance to your global goal by continually destroying the status quo to install a new status quo which you then also destroy. The two world wars come to mind. With each new status quo you move closer to your planned outcome. Wars and mass murder are to Sabbatians a collective blood sacrifice ritual. They are obsessed with death for many reasons and one is that death is an inversion of life. Satanists and Sabbatians are obsessed with death and often target churches and churchyards for their rituals. Inversion-obsessed Sabbatians explain the use of inverted symbolism including the *inverted* pentagram and *inverted* cross. The inversion of the cross has been related to targeting Christianity, but the cross was a religious symbol long before Christianity and its inversion is a statement about the Sabbatian mentality and goals more than any single religion.

Sabbatians operating in Germany were behind the rise of the occult-obsessed Nazis and the subsequent Jewish exodus from Germany and Europe to Palestine and the United States after World War Two. The Rothschild dynasty was at the forefront of this both as political manipulators and by funding the operation. Why would Sabbatians help to orchestrate the horrors inflicted on Jews by the Nazis and by Stalin after they organised the Russian Revolution? Sabbatians hate Jews and their religion, that's why. They pose as Jews and secure positions of control within Jewish society and play the 'anti-Semitism' card to protect themselves from exposure

through a global network of organisations answering to the Sabbatian-created-and-controlled globe-spanning intelligence network that involves a stunning web of military-intelligence operatives and operations for a tiny country of just nine million. Among them are Jewish assets who are not Sabbatians but have been convinced by them that what they are doing is for the good of Israel and the Jewish community to protect them from what they have been programmed since childhood to believe is a Jew-hating hostile world. The Jewish community is just a highly convenient cover to hide the true nature of Sabbatians. Anyone getting close to exposing their game is accused by Sabbatian place-people and gofers of 'anti-Semitism' and claiming that all Jews are part of a plot to take over the world. I am not saying that. I am saying that Sabbatians – the *real* Jew-haters – have infiltrated the Jewish community to use them both as a cover and an 'anti-Semitic' defence against exposure. Thus we have the Anti-Semitism Industry targeted researchers in this way and most Jewish people think this is justified and genuine. They don't know that their 'Jewish' leaders and institutions of state, intelligence and military are not controlled by Jews at all, but cultists and stooges of Sabbatian-Frankism. I once added my name to a pro-Jewish freedom petition online and the next time I looked my name was gone and text had been added to the petition blurb to attack me as an 'anti-Semite' such is the scale of perceptual programming.

## **Moving on America**

I tell the story in *The Trigger* and a chapter called 'Atlantic Crossing' how particularly after Israel was established the Sabbatians moved in on the United States and eventually grasped control of government administration, the political system via both Democrats and Republicans, the intelligence community like the CIA and National Security Agency (NSA), the Pentagon and mass media. Through this seriously compartmentalised network Sabbatians and their operatives in Mossad, Israeli Defense Forces (IDF) and US agencies pulled off 9/11 and blamed it on 19 'Al-Qaeda hijackers' dominated by men from, or connected to, Sabbatian-ruled Saudi

Arabia. The '19' were not even on the planes let alone flew those big passenger jets into buildings while being largely incompetent at piloting one-engine light aircraft. 'Hijacker' Hani Hanjour who is said to have flown American Airlines Flight 77 into the Pentagon with a turn and manoeuvre most professional pilots said they would have struggled to do was banned from renting a small plane by instructors at the Freeway Airport in Bowie, Maryland, just *six weeks* earlier on the grounds that he was an incompetent pilot. The Jewish population of the world is just 0.2 percent with even that almost entirely concentrated in Israel (75 percent Jewish) and the United States (around two percent). This two percent and globally 0.2 percent refers to *Jewish* people and not Sabbatian interlopers who are a fraction of that fraction. What a sobering thought when you think of the fantastic influence on world affairs of tiny Israel and that the Project for the New America Century (PNAC) which laid out the blueprint in September, 2000, for America's war on terror and regime change wars in Iraq, Libya and Syria was founded and dominated by Sabbatians known as 'Neocons'. The document conceded that this plan would not be supported politically or publicly without a major attack on American soil and a Problem-Reaction-Solution excuse to send troops to war across the Middle East. Sabbatian Neocons said:

... [The] process of transformation ... [war and regime change] ... is likely to be a long one, absent some catastrophic and catalysing event – like a new Pearl Harbor.

Four months later many of those who produced that document came to power with their inane puppet George Bush from the long-time Sabbatian Bush family. They included Sabbatian Dick Cheney who was officially vice-president, but really de-facto president for the entirety of the 'Bush' government. Nine months after the 'Bush' inauguration came what Bush called at the time 'the Pearl Harbor of the 21st century' and with typical Sabbatian timing and symbolism 2001 was the 60th anniversary of the attack in 1941 by the Japanese Air Force on Pearl Harbor, Hawaii, which allowed President Franklin Delano Roosevelt to take the United States into a Sabbatian-

instigated Second World War that he said in his election campaign that he never would. The evidence is overwhelming that Roosevelt and his military and intelligence networks knew the attack was coming and did nothing to stop it, but they did make sure that America's most essential naval ships were not in Hawaii at the time. Three thousand Americans died in the Pearl Harbor attacks as they did on September 11th. By the 9/11 year of 2001 Sabbatians had widely infiltrated the US government, military and intelligence operations and used their compartmentalised assets to pull off the 'Al-Qaeda' attacks. If you read *The Trigger* it will blow your mind to see the utterly staggering concentration of 'Jewish' operatives (Sabbatian infiltrators) in essential positions of political, security, legal, law enforcement, financial and business power before, during, and after the attacks to make them happen, carry them out, and then cover their tracks – and I do mean *staggering* when you think of that 0.2 percent of the world population and two percent of Americans which are Jewish while Sabbatian infiltrators are a fraction of that. A central foundation of the 9/11 conspiracy was the hijacking of government, military, Air Force and intelligence computer systems in real time through 'back-door' access made possible by Israeli (Sabbatian) 'cyber security' software. Sabbatian-controlled Israel is on the way to rivalling Silicon Valley for domination of cyberspace and is becoming the dominant force in cyber-security which gives them access to entire computer systems and their passcodes across the world. Then add to this that Zionists head (officially) Silicon Valley giants like Google (Larry Page and Sergey Brin), Google-owned YouTube (Susan Wojcicki), Facebook (Mark Zuckerberg and Sheryl Sandberg), and Apple (Chairman Arthur D. Levinson), and that ultra-Zionist hedge fund billionaire Paul Singer has a \$1 billion stake in Twitter which is only nominally headed by 'CEO' pothead Jack Dorsey. As cable news host Tucker Carlson said of Dorsey: 'There used to be debate in the medical community whether dropping a ton of acid had permanent effects and I think that debate has now ended.' Carlson made the comment after Dorsey told a hearing on Capitol Hill (if you cut through his bullshit) that he



believed in free speech so long as he got to decide what you can hear and see. These 'big names' of Silicon Valley are only front men and women for the Global Cult, not least the Sabbatians, who are the true controllers of these corporations. Does anyone still wonder why these same people and companies have been ferociously censoring and banning people (like me) for exposing any aspect of the Cult agenda and especially the truth about the 'Covid' hoax which Sabbatians have orchestrated?

The Jeffrey Epstein paedophile ring was a Sabbatian operation. He was officially 'Jewish' but he was a Sabbatian and women abused by the ring have told me about the high number of 'Jewish' people involved. The Epstein horror has Sabbatian written all over it and matches perfectly their modus operandi and obsession with sex and ritual. Epstein was running a Sabbatian blackmail ring in which famous people with political and other influence were provided with young girls for sex while everything was being filmed and recorded on hidden cameras and microphones at his New York house, Caribbean island and other properties. Epstein survivors have described this surveillance system to me and some have gone public. Once the famous politician or other figure knew he or she was on video they tended to do whatever they were told. Here we go again ...when you've got them by the balls their hearts and minds will follow. Sabbatians use this blackmail technique on a wide scale across the world to entrap politicians and others they need to act as demanded. Epstein's private plane, the infamous 'Lolita Express', had many well-known passengers including Bill Clinton while Bill Gates has flown on an Epstein plane and met with him four years after Epstein had been jailed for paedophilia. They subsequently met many times at Epstein's home in New York according to a witness who was there. Epstein's infamous side-kick was Ghislaine Maxwell, daughter of Mossad agent and ultra-Zionist mega-crooked British businessman, Bob Maxwell, who at one time owned the *Daily Mirror* newspaper. Maxwell was murdered at sea on his boat in 1991 by Sabbatian-controlled Mossad when he became a liability with his

business empire collapsing as a former Mossad operative has confirmed (see *The Trigger*).

### **Money, money, money, funny money ...**

Before I come to the Sabbatian connection with the last three US presidents I will lay out the crucial importance to Sabbatians of controlling banking and finance. Sabbatian Mayer Amschel Rothschild set out to dominate this arena in his family's quest for total global control. What is freedom? It is, in effect, choice. The more choices you have the freer you are and the fewer your choices the more you are enslaved. In the global structure created over centuries by Sabbatians the biggest decider and restrictor of choice is ... money. Across the world if you ask people what they would like to do with their lives and why they are not doing that they will reply 'I don't have the money'. This is the idea. A global elite of multi-billionaires are described as 'greedy' and that is true on one level; but control of money – who has it and who doesn't – is not primarily about greed. It's about control. Sabbatians have seized ever more control of finance and sucked the wealth of the world out of the hands of the population. We talk now, after all, about the 'One-percent' and even then the wealthiest are a lot fewer even than that. This has been made possible by a money scam so outrageous and so vast it could rightly be called the scam of scams founded on creating 'money' out of nothing and 'loaning' that with interest to the population. Money out of nothing is called 'credit'. Sabbatians have asserted control over governments and banking ever more completely through the centuries and secured financial laws that allow banks to lend hugely more than they have on deposit in a confidence trick known as fractional reserve lending. Imagine if you could lend money that doesn't exist and charge the recipient interest for doing so. You would end up in jail. Bankers by contrast end up in mansions, private jets, Malibu and Monaco.

Banks are only required to keep a fraction of their deposits and wealth in their vaults and they are allowed to lend 'money' they don't have called 'credit'. Go into a bank for a loan and if you succeed

the banker will not move any real wealth into your account. They will type into your account the amount of the agreed 'loan' – say £100,000. This is not wealth that really exists; it is non-existent, fresh-air, created-out-of-nothing 'credit' which has never, does not, and will never exist except in theory. Credit is backed by nothing except wind and only has buying power because people think that it has buying power and accept it in return for property, goods and services. I have described this situation as like those cartoon characters you see chasing each other and when they run over the edge of a cliff they keep running forward on fresh air until one of them looks down, realises what's happened, and they all crash into the ravine. The whole foundation of the Sabbatian financial system is to stop people looking down except for periodic moments when they want to crash the system (as in 2008 and 2020 ongoing) and reap the rewards from all the property, businesses and wealth their borrowers had signed over as 'collateral' in return for a 'loan' of fresh air. Most people think that money is somehow created by governments when it comes into existence from the start as a debt through banks 'lending' illusory money called credit. Yes, the very currency of exchange is a *debt* from day one issued as an interest-bearing loan. Why don't governments create money interest-free and lend it to their people interest-free? Governments are controlled by Sabbatians and the financial system is controlled by Sabbatians for whom interest-free money would be a nightmare come true. Sabbatians underpin their financial domination through their global network of central banks, including the privately-owned US Federal Reserve and Britain's Bank of England, and this is orchestrated by a privately-owned central bank coordination body called the Bank for International Settlements in Basle, Switzerland, created by the usual suspects including the Rockefellers and Rothschilds. Central bank chiefs don't answer to governments or the people. They answer to the Bank for International Settlements or, in other words, the Global Cult which is dominated today by Sabbatians.

## **Built-in disaster**

There are so many constituent scams within the overall banking scam. When you take out a loan of thin-air credit only the amount of that loan is theoretically brought into circulation to add to the amount in circulation; but you are paying back the principle plus interest. The additional interest is not created and this means that with every 'loan' there is a shortfall in the money in circulation between what is borrowed and what has to be paid back. There is never even close to enough money in circulation to repay all outstanding public and private debt including interest. Coldly weaved in the very fabric of the system is the certainty that some will lose their homes, businesses and possessions to the banking 'lender'. This is less obvious in times of 'boom' when the amount of money in circulation (and the debt) is expanding through more people wanting and getting loans. When a downturn comes and the money supply contracts it becomes painfully obvious that there is not enough money to service all debt and interest. This is less obvious in times of 'boom' when the amount of money in circulation (and the debt) is expanding through more people wanting and getting loans. When a downturn comes and the money supply contracts and it becomes painfully obvious – as in 2008 and currently – that there is not enough money to service all debt and interest. Sabbatian banksters have been leading the human population through a calculated series of booms (more debt incurred) and busts (when the debt can't be repaid and the banks get the debtor's tangible wealth in exchange for non-existent 'credit'). With each 'bust' Sabbatian bankers have absorbed more of the world's tangible wealth and we end up with the One-percent. Governments are in bankruptcy levels of debt to the same system and are therefore owned by a system they do not control. The Federal Reserve, 'America's central bank', is privately-owned and American presidents only nominally appoint its chairman or woman to maintain the illusion that it's an arm of government. It's not. The 'Fed' is a cartel of private banks which handed billions to its associates and friends after the crash of 2008 and has been Sabbatian-controlled since it was manipulated into being in 1913 through the covert trickery of Rothschild banking agents Jacob Schiff and Paul

Warburg, and the Sabbatian Rockefeller family. Somehow from a Jewish population of two-percent and globally 0.2 percent (Sabbatian interlopers remember are far smaller) ultra-Zionists headed the Federal Reserve for 31 years between 1987 and 2018 in the form of Alan Greenspan, Bernard Bernanke and Janet Yellen (now Biden's Treasury Secretary) with Yellen's deputy chairman a Israeli-American dual citizen and ultra-Zionist Stanley Fischer, a former governor of the Bank of Israel. Ultra-Zionist Fed chiefs spanned the presidencies of Ronald Reagan ('Republican'), Father George Bush ('Republican'), Bill Clinton ('Democrat'), Boy George Bush ('Republican') and Barack Obama ('Democrat'). We should really add the pre-Greenspan chairman, Paul Adolph Volcker, 'appointed' by Jimmy Carter ('Democrat') who ran the Fed between 1979 and 1987 during the Carter and Reagan administrations before Greenspan took over. Volcker was a long-time associate and business partner of the Rothschilds. No matter what the 'party' officially in power the United States economy was directed by the same force. Here are members of the Obama, Trump and Biden administrations and see if you can make out a common theme.

### **Barack Obama ('Democrat')**

Ultra-Zionists Robert Rubin, Larry Summers, and Timothy Geithner ran the US Treasury in the Clinton administration and two of them reappeared with Obama. Ultra-Zionist Fed chairman Alan Greenspan had manipulated the crash of 2008 through deregulation and jumped ship just before the disaster to make way for ultra-Zionist Bernard Bernanke to hand out trillions to Sabbatian 'too big to fail' banks and businesses, including the ubiquitous ultra-Zionist Goldman Sachs which has an ongoing revolving door operation between itself and major financial positions in government worldwide. Obama inherited the fallout of the crash when he took office in January, 2009, and fortunately he had the support of his ultra-Zionist White House Chief of Staff Rahm Emmanuel, son of a terrorist who helped to bomb Israel into being in 1948, and his ultra-Zionist senior adviser David Axelrod, chief strategist in Obama's two

successful presidential campaigns. Emmanuel, later mayor of Chicago and former senior fundraiser and strategist for Bill Clinton, is an example of the Sabbatian policy after Israel was established of migrating insider families to America so their children would be born American citizens. 'Obama' chose this financial team throughout his administration to respond to the Sabbatian-instigated crisis:

Timothy Geithner (ultra-Zionist) Treasury Secretary; Jacob J. Lew, Treasury Secretary; Larry Summers (ultra-Zionist), director of the White House National Economic Council; Paul Adolph Volcker (Rothschild business partner), chairman of the Economic Recovery Advisory Board; Peter Orszag (ultra-Zionist), director of the Office of Management and Budget overseeing all government spending; Penny Pritzker (ultra-Zionist), Commerce Secretary; Jared Bernstein (ultra-Zionist), chief economist and economic policy adviser to Vice President Joe Biden; Mary Schapiro (ultra-Zionist), chair of the Securities and Exchange Commission (SEC); Gary Gensler (ultra-Zionist), chairman of the Commodity Futures Trading Commission (CFTC); Sheila Bair (ultra-Zionist), chair of the Federal Deposit Insurance Corporation (FDIC); Karen Mills (ultra-Zionist), head of the Small Business Administration (SBA); Kenneth Feinberg (ultra-Zionist), Special Master for Executive [bail-out] Compensation. Feinberg would be appointed to oversee compensation (with strings) to 9/11 victims and families in a campaign to stop them having their day in court to question the official story. At the same time ultra-Zionist Bernard Bernanke was chairman of the Federal Reserve and these are only some of the ultra-Zionists with allegiance to Sabbatian-controlled Israel in the Obama government. Obama's biggest corporate donor was ultra-Zionist Goldman Sachs which had employed many in his administration.

### **Donald Trump ('Republican')**

Trump claimed to be an outsider (he wasn't) who had come to 'drain the swamp'. He embarked on this goal by immediately appointing ultra-Zionist Steve Mnuchin, a Goldman Sachs employee for 17

years, as his Treasury Secretary. Others included Gary Cohn (ultra-Zionist), chief operating officer of Goldman Sachs, his first Director of the National Economic Council and chief economic adviser, who was later replaced by Larry Kudlow (ultra-Zionist). Trump's senior adviser throughout his four years in the White House was his sinister son-in-law Jared Kushner, a life-long friend of Israel Prime Minister Benjamin Netanyahu. Kushner is the son of a convicted crook who was pardoned by Trump in his last days in office. Other ultra-Zionists in the Trump administration included: Stephen Miller, Senior Policy Adviser; Avrahm Berkowitz, Deputy Adviser to Trump and his Senior Adviser Jared Kushner; Ivanka Trump, Adviser to the President, who converted to Judaism when she married Jared Kushner; David Friedman, Trump lawyer and Ambassador to Israel; Jason Greenblatt, Trump Organization executive vice president and chief legal officer, who was made Special Representative for International Negotiations and the Israeli-Palestinian Conflict; Rod Rosenstein, Deputy Attorney General; Elliot Abrams, Special Representative for Venezuela, then Iran; John Eisenberg, National Security Council Legal Adviser and Deputy Council to the President for National Security Affairs; Anne Neuberger, Deputy National Manager, National Security Agency; Ezra Cohen-Watnick, Acting Under Secretary of Defense for Intelligence; Elan Carr, Special Envoy to monitor and combat anti-Semitism; Len Khodorkovsky, Deputy Special Envoy to monitor and combat anti-Semitism; Reed Cordish, Assistant to the President, Intragovernmental and Technology Initiatives. Trump Vice President Mike Pence and Secretary of State Mike Pompeo, both Christian Zionists, were also vehement supporters of Israel and its goals and ambitions.

Donald 'free-speech believer' Trump pardoned a number of financial and violent criminals while ignoring calls to pardon Julian Assange and Edward Snowden whose crimes are revealing highly relevant information about government manipulation and corruption and the widespread illegal surveillance of the American people by US 'security' agencies. It's so good to know that Trump is on the side of freedom and justice and not mega-criminals with

allegiance to Sabbatian-controlled Israel. These included a pardon for Israeli spy Jonathan Pollard who was jailed for life in 1987 under the Espionage Act. Aviem Sella, the Mossad agent who recruited Pollard, was also pardoned by Trump while Assange sat in jail and Snowden remained in exile in Russia. Sella had 'fled' (was helped to escape) to Israel in 1987 and was never extradited despite being charged under the Espionage Act. A Trump White House statement said that Sella's clemency had been 'supported by Benjamin Netanyahu, Ron Dermer, Israel's US Ambassador, David Friedman, US Ambassador to Israel and Miriam Adelson, wife of leading Trump donor Sheldon Adelson who died shortly before. Other friends of Jared Kushner were pardoned along with Sholom Weiss who was believed to be serving the longest-ever white-collar prison sentence of more than 800 years in 2000. The sentence was commuted of Ponzi-schemer Eliyahu Weinstein who defrauded Jews and others out of \$200 million. I did mention that Assange and Snowden were ignored, right? Trump gave Sabbatians almost everything they asked for in military and political support, moving the US Embassy from Tel Aviv to Jerusalem with its critical symbolic and literal implications for Palestinian statehood, and the 'deal of the Century' designed by Jared Kushner and David Friedman which gave the Sabbatian Israeli government the green light to substantially expand its already widespread program of building illegal Jewish-only settlements in the occupied land of the West Bank. This made a two-state 'solution' impossible by seizing all the land of a potential Palestinian homeland and that had been the plan since 1948 and then 1967 when the Arab-controlled Gaza Strip, West Bank, Sinai Peninsula and Syrian Golan Heights were occupied by Israel. All the talks about talks and road maps and delays have been buying time until the West Bank was physically occupied by Israeli real estate. Trump would have to be a monumentally ill-informed idiot not to see that this was the plan he was helping to complete. The Trump administration was in so many ways the Kushner administration which means the Netanyahu administration which means the Sabbatian administration. I understand why many opposing Cult fascism in all its forms gravitated to Trump, but he



was a crucial part of the Sabbatian plan and I will deal with this in the next chapter.

## **Joe Biden ('Democrat')**

A barely cognitive Joe Biden took over the presidency in January, 2021, along with his fellow empty shell, Vice-President Kamala Harris, as the latest Sabbatian gofers to enter the White House. Names on the door may have changed and the 'party' – the force behind them remained the same as Zionists were appointed to a stream of pivotal areas relating to Sabbatian plans and policy. They included: Janet Yellen, Treasury Secretary, former head of the Federal Reserve, and still another ultra-Zionist running the US Treasury after Mnuchin (Trump), Lew and Geithner (Obama), and Summers and Rubin (Clinton); Anthony Blinken, Secretary of State; Wendy Sherman, Deputy Secretary of State (so that's 'Biden's' Sabbatian foreign policy sorted); Jeff Zients, White House coronavirus coordinator; Rochelle Walensky, head of the Centers for Disease Control; Rachel Levine, transgender deputy health secretary (that's 'Covid' hoax policy under control); Merrick Garland, Attorney General; Alejandro Mayorkas, Secretary of Homeland Security; Cass Sunstein, Homeland Security with responsibility for new immigration laws; Avril Haines, Director of National Intelligence; Anne Neuberger, National Security Agency cybersecurity director (note, cybersecurity); David Cohen, CIA Deputy Director; Ronald Klain, Biden's Chief of Staff (see Rahm Emanuel); Eric Lander, a 'leading geneticist', Office of Science and Technology Policy director (see Smart Grid, synthetic biology agenda); Jessica Rosenworcel, acting head of the Federal Communications Commission (FCC) which controls Smart Grid technology policy and electromagnetic communication systems including 5G. How can it be that so many pivotal positions are held by two-percent of the American population and 0.2 percent of the world population administration after administration no matter who is the president and what is the party? It's a coincidence? Of course it's not and this is why Sabbatians have built their colossal global web of interlocking 'anti-

hate' hate groups to condemn anyone who asks these glaring questions as an 'anti-Semite'. The way that Jewish people horrifically abused in Sabbatian-backed Nazi Germany are exploited to this end is stomach-turning and disgusting beyond words.

## **Political fusion**

Sabbatian manipulation has reversed the roles of Republicans and Democrats and the same has happened in Britain with the Conservative and Labour Parties. Republicans and Conservatives were always labelled the 'right' and Democrats and Labour the 'left', but look at the policy positions now and the Democrat-Labour 'left' has moved further to the 'right' than Republicans and Conservatives under the banner of 'Woke', the Cult-created far-right tyranny. Where once the Democrat-Labour 'left' defended free speech and human rights they now seek to delete them and as I said earlier despite the 'Covid' fascism of the Jackboot Johnson Conservative government in the UK the Labour Party of leader Keir Starmer demanded even more extreme measures. The Labour Party has been very publicly absorbed by Sabbatians after a political and media onslaught against the previous leader, the weak and inept Jeremy Corbyn, over made-up allegations of 'anti-Semitism' both by him and his party. The plan was clear with this 'anti-Semite' propaganda and what was required in response was a swift and decisive 'fuck off' from Corbyn and a statement to expose the Anti-Semitism Industry (Sabbatian) attempt to silence Labour criticism of the Israeli government (Sabbatians) and purge the party of all dissent against the extremes of ultra-Zionism (Sabbatians). Instead Corbyn and his party fell to their knees and appeased the abusers which, by definition, is impossible. Appeasing one demand leads only to a new demand to be appeased until takeover is complete. Like I say – 'fuck off' would have been a much more effective policy and I have used it myself with great effect over the years when Sabbatians are on my case which is most of the time. I consider that fact a great compliment, by the way. The outcome of the Labour Party capitulation is that we now have a Sabbatian-controlled

Conservative Party 'opposed' by a Sabbatian-controlled Labour Party in a one-party Sabbatian state that hurtles towards the extremes of tyranny (the Sabbatian cult agenda). In America the situation is the same. Labour's Keir Starmer spends his days on his knees with his tongue out pointing to Tel Aviv, or I guess now Jerusalem, while Boris Johnson has an 'anti-Semitism czar' in the form of former Labour MP John Mann who keeps Starmer company on his prayer mat.

Sabbatian influence can be seen in Jewish members of the Labour Party who have been ejected for criticism of Israel including those from families that suffered in Nazi Germany. Sabbatians despise real Jewish people and target them even more harshly because it is so much more difficult to dub them 'anti-Semitic' although in their desperation they do try.

## CHAPTER THREE

### **The Pushbacker sting**

*Until you realize how easy it is for your mind to be manipulated, you remain the puppet of someone else's game*

Evita Ochel

I will use the presidencies of Trump and Biden to show how the manipulation of the one-party state plays out behind the illusion of political choice across the world. No two presidencies could – on the face of it – be more different and apparently at odds in terms of direction and policy.

A Renegade Mind sees beyond the obvious and focuses on outcomes and consequences and not image, words and waffle. The Cult embarked on a campaign to divide America between those who blindly support its agenda (the mentality known as 'Woke') and those who are pushing back on where the Cult and its Sabbatians want to go. This presents infinite possibilities for dividing and ruling the population by setting them at war with each other and allows a perceptual ring fence of demonisation to encircle the Pushbackers in a modern version of the Little Big Horn in 1876 when American cavalry led by Lieutenant Colonel George Custer were drawn into a trap, surrounded and killed by Native American tribes defending their land of thousands of years from being seized by the government. In this modern version the roles are reversed and it's those defending themselves from the Sabbatian government who are surrounded and the government that's seeking to destroy them. This trap was set years ago and to explain how we must return to 2016

and the emergence of Donald Trump as a candidate to be President of the United States. He set out to overcome the best part of 20 other candidates in the Republican Party before and during the primaries and was not considered by many in those early stages to have a prayer of living in the White House. The Republican Party was said to have great reservations about Trump and yet somehow he won the nomination. When you know how American politics works – politics in general – there is no way that Trump could have become the party's candidate unless the Sabbatian-controlled 'Neocons' that run the Republican Party wanted that to happen. We saw the proof in emails and documents made public by WikiLeaks that the Democratic Party hierarchy, or Democons, systematically undermined the campaign of Bernie Sanders to make sure that Sabbatian gofer Hillary Clinton won the nomination to be their presidential candidate. If the Democons could do that then the Neocons in the Republican Party could have derailed Trump in the same way. But they didn't and at that stage I began to conclude that Trump could well be the one chosen to be president. If that was the case the 'why' was pretty clear to see – the goal of dividing America between Cult agenda-supporting Wokers and Pushbackers who gravitated to Trump because he was telling them what they wanted to hear. His constituency of support had been increasingly ignored and voiceless for decades and profoundly through the eight years of Sabbatian puppet Barack Obama. Now here was someone speaking their language of pulling back from the incessant globalisation of political and economic power, the exporting of American jobs to China and elsewhere by 'American' (Sabbatian) corporations, the deletion of free speech, and the mass immigration policies that had further devastated job opportunities for the urban working class of all races and the once American heartlands of the Midwest.

### **Beware the forked tongue**

Those people collectively sighed with relief that at last a political leader was apparently on their side, but another trait of the Renegade Mind is that you look even harder at people telling you

what you want to hear than those who are telling you otherwise. Obviously as I said earlier people wish what they want to hear to be true and genuine and they are much more likely to believe that than someone saying what they don't want to hear and don't want to be true. Sales people are taught to be skilled in eliciting by calculated questioning what their customers want to hear and repeating that back to them as their own opinion to get their targets to like and trust them. Assets of the Cult are also sales people in the sense of selling perception. To read Cult manipulation you have to play the long and expanded game and not fall for the Vaudeville show of party politics. Both American parties are vehicles for the Cult and they exploit them in different ways depending on what the agenda requires at that moment. Trump and the Republicans were used to be the focus of dividing America and isolating Pushbackers to open the way for a Biden presidency to become the most extreme in American history by advancing the full-blown Woke (Cult) agenda with the aim of destroying and silencing Pushbackers now labelled Nazi Trump supporters and white supremacists.

Sabbatians wanted Trump in office for the reasons described by ultra-Zionist Saul Alinsky (1909-1972) who was promoting the Woke philosophy through 'community organising' long before anyone had heard of it. In those days it still went by its traditional name of Marxism. The reason for the manipulated Trump phenomenon was laid out in Alinsky's 1971 book, *Rules for Radicals*, which was his blueprint for overthrowing democratic and other regimes and replacing them with Sabbatian Marxism. Not surprisingly his to-do list was evident in the Sabbatian French and Russian 'Revolutions' and that in China which will become very relevant in the next chapter about the 'Covid' hoax. Among Alinsky's followers have been the deeply corrupt Barack Obama, House Speaker Nancy Pelosi and Hillary Clinton who described him as a 'hero'. All three are Sabbatian stooges with Pelosi personifying the arrogant corrupt idiocy that so widely fronts up for the Cult inner core. Predictably as a Sabbatian advocate of the 'light-bringer' Alinsky features Lucifer on the dedication page of his book as the original radical who gained

his own kingdom ('Earth' as we shall see). One of Alinsky's golden radical rules was to pick an individual and focus all attention, hatred and blame on them and not to target faceless bureaucracies and corporations. *Rules for Radicals* is really a Sabbatian handbook with its contents repeatedly employed all over the world for centuries and why wouldn't Sabbatians bring to power their designer-villain to be used as the individual on which all attention, hatred and blame was bestowed? This is what they did and the only question for me is how much Trump knew that and how much he was manipulated. A bit of both, I suspect. This was Alinsky's Trump technique from a man who died in 1972. The technique has spanned history:

Pick the target, freeze it, personalize it, polarize it. Don't try to attack abstract corporations or bureaucracies. Identify a responsible individual. Ignore attempts to shift or spread the blame.

From the moment Trump came to illusory power everything was about him. It wasn't about Republican policy or opinion, but all about Trump. Everything he did was presented in negative, derogatory and abusive terms by the Sabbatian-dominated media led by Cult operations such as CNN, MSNBC, *The New York Times* and the Jeff Bezos-owned *Washington Post* – 'Pick the target, freeze it, personalize it, polarize it.' Trump was turned into a demon to be vilified by those who hated him and a demi-god loved by those who worshipped him. This, in turn, had his supporters, too, presented as equally demonic in preparation for the punchline later down the line when Biden was about to take office. It was here's a Trump, there's a Trump, everywhere a Trump, Trump. Virtually every news story or happening was filtered through the lens of 'The Donald'. You loved him or hated him and which one you chose was said to define you as Satan's spawn or a paragon of virtue. Even supporting some Trump policies or statements and not others was enough for an assault on your character. No shades of grey were or are allowed. Everything is black and white (literally and figuratively). A Californian I knew had her head utterly scrambled by her hatred for Trump while telling people they should love each other. She was so totally consumed by

Trump Derangement Syndrome as it became to be known that this glaring contradiction would never have occurred to her. By definition anyone who criticised Trump or praised his opponents was a hero and this lady described Joe Biden as 'a kind, honest gentleman' when he's a provable liar, mega-crook and vicious piece of work to boot. Sabbatians had indeed divided America using Trump as the fall-guy and all along the clock was ticking on the consequences for his supporters.

### **In hock to his masters**

Trump gave Sabbatians via Israel almost everything they wanted in his four years. Ask and you shall receive was the dynamic between himself and Benjamin Netanyahu orchestrated by Trump's ultra-Zionist son-in-law Jared Kushner, his ultra-Zionist Ambassador to Israel, David Friedman, and ultra-Zionist 'Israel adviser', Jason Greenblatt. The last two were central to the running and protecting from collapse of his business empire, the Trump Organisation, and colossal business failures made him forever beholding to Sabbatian networks that bailed him out. By the start of the 1990s Trump owed \$4 billion to banks that he couldn't pay and almost \$1 billion of that was down to him personally and not his companies. This mega-disaster was the result of building two new casinos in Atlantic City and buying the enormous Taj Mahal operation which led to crippling debt payments. He had borrowed fantastic sums from 72 banks with major Sabbatian connections and although the scale of debt should have had him living in a tent alongside the highway they never foreclosed. A plan was devised to lift Trump from the mire by BT Securities Corporation and Rothschild Inc. and the case was handled by Wilber Ross who had worked for the Rothschilds for 27 years. Ross would be named US Commerce Secretary after Trump's election. Another crucial figure in saving Trump was ultra-Zionist 'investor' Carl Icahn who bought the Taj Mahal casino. Icahn was made special economic adviser on financial regulation in the Trump administration. He didn't stay long but still managed to find time to make a tidy sum of a reported \$31.3 million when he sold his



holdings affected by the price of steel three days before Trump imposed a 235 percent tariff on steel imports. What amazing bits of luck these people have. Trump and Sabbatian operatives have long had a close association and his mentor and legal adviser from the early 1970s until 1986 was the dark and genetically corrupt ultra-Zionist Roy Cohn who was chief counsel to Senator Joseph McCarthy's 'communist' witch-hunt in the 1950s. *Esquire* magazine published an article about Cohn with the headline 'Don't mess with Roy Cohn'. He was described as the most feared lawyer in New York and 'a ruthless master of dirty tricks ... [with] ... more than one Mafia Don on speed dial'. Cohn's influence, contacts, support and protection made Trump a front man for Sabbatians in New York with their connections to one of Cohn's many criminal employers, the 'Russian' Sabbatian Mafia. Israel-centric media mogul Rupert Murdoch was introduced to Trump by Cohn and they started a long friendship. Cohn died in 1986 weeks after being disbarred for unethical conduct by the Appellate Division of the New York State Supreme Court. The wheels of justice do indeed run slow given the length of Cohn's crooked career.

## **QAnon-sense**

We are asked to believe that Donald Trump with his fundamental connections to Sabbatian networks and operatives has been leading the fight to stop the Sabbatian agenda for the fascistic control of America and the world. Sure he has. A man entrapped during his years in the White House by Sabbatian operatives and whose biggest financial donor was casino billionaire Sheldon Adelson who was Sabbatian to his DNA?? Oh, do come on. Trump has been used to divide America and isolate Pushbackers on the Cult agenda under the heading of 'Trump supporters', 'insurrectionists' and 'white supremacists'. The US Intelligence/Mossad Psyop or psychological operation known as QAnon emerged during the Trump years as a central pillar in the Sabbatian campaign to lead Pushbackers into the trap set by those that wished to destroy them. I knew from the start that QAnon was a scam because I had seen the same scenario many

times before over 30 years under different names and I had written about one in particular in the books. 'Not again' was my reaction when QAnon came to the fore. The same script is pulled out every few years and a new name added to the letterhead. The story always takes the same form: 'Insiders' or 'the good guys' in the government-intelligence-military 'Deep State' apparatus were going to instigate mass arrests of the 'bad guys' which would include the Rockefellers, Rothschilds, Barack Obama, Hillary Clinton, George Soros, etc., etc. Dates are given for when the 'good guys' are going to move in, but the dates pass without incident and new dates are given which pass without incident. The central message to Pushbackers in each case is that they don't have to do anything because there is 'a plan' and it is all going to be sorted by the 'good guys' on the inside. 'Trust the plan' was a QAnon mantra when the only plan was to misdirect Pushbackers into putting their trust in a Psyop they believed to be real. Beware, beware, those who tell you what you want to hear and always check it out. Right up to Biden's inauguration QAnon was still claiming that 'the Storm' was coming and Trump would stay on as president when Biden and his cronies were arrested and jailed. It was never going to happen and of course it didn't, but what did happen as a result provided that punchline to the Sabbatian Trump/QAnon Psyop.

On January 6th, 2021, a very big crowd of Trump supporters gathered in the National Mall in Washington DC down from the Capitol Building to protest at what they believed to be widespread corruption and vote fraud that stopped Trump being re-elected for a second term as president in November, 2020. I say as someone that does not support Trump or Biden that the evidence is clear that major vote-fixing went on to favour Biden, a man with cognitive problems so advanced he can often hardly string a sentence together without reading the words written for him on the Teleprompter. Glaring ballot discrepancies included serious questions about electronic voting machines that make vote rigging a comparative cinch and hundreds of thousands of paper votes that suddenly appeared during already advanced vote counts and virtually all of

them for Biden. Early Trump leads in crucial swing states suddenly began to close and disappear. The pandemic hoax was used as the excuse to issue almost limitless numbers of mail-in ballots with no checks to establish that the recipients were still alive or lived at that address. They were sent to streams of people who had not even asked for them. Private organisations were employed to gather these ballots and who knows what they did with them before they turned up at the counts. The American election system has been manipulated over decades to become a sick joke with more holes than a Swiss cheese for the express purpose of dictating the results. Then there was the criminal manipulation of information by Sabbatian tech giants like Facebook, Twitter and Google-owned YouTube which deleted pro-Trump, anti-Biden accounts and posts while everything in support of Biden was left alone. Sabbatians wanted Biden to win because after the dividing of America it was time for full-on Woke and every aspect of the Cult agenda to be unleashed.

### **Hunter gatherer**

Extreme Silicon Valley bias included blocking information by the *New York Post* exposing a Biden scandal that should have ended his bid for president in the final weeks of the campaign. Hunter Biden, his monumentally corrupt son, is reported to have sent a laptop to be repaired at a local store and failed to return for it. Time passed until the laptop became the property of the store for non-payment of the bill. When the owner saw what was on the hard drive he gave a copy to the FBI who did nothing even though it confirmed widespread corruption in which the Joe Biden family were using his political position, especially when he was vice president to Obama, to make multiple millions in countries around the world and most notably Ukraine and China. Hunter Biden's one-time business partner Tony Bobulinski went public when the story broke in the *New York Post* to confirm the corruption he saw and that Joe Biden not only knew what was going on he also profited from the spoils. Millions were handed over by a Chinese company with close

connections – like all major businesses in China – to the Chinese communist party of President Xi Jinping. Joe Biden even boasted at a meeting of the Cult's World Economic Forum that as vice president he had ordered the government of Ukraine to fire a prosecutor. What he didn't mention was that the same man just happened to be investigating an energy company which was part of Hunter Biden's corrupt portfolio. The company was paying him big bucks for no other reason than the influence his father had. Overnight Biden's presidential campaign should have been over given that he had lied publicly about not knowing what his son was doing. Instead almost the entire Sabbatian-owned mainstream media and Sabbatian-owned Silicon Valley suppressed circulation of the story. This alone went a mighty way to rigging the election of 2020. Cult assets like Mark Zuckerberg at Facebook also spent hundreds of millions to be used in support of Biden and vote 'administration'.

The Cult had used Trump as the focus to divide America and was now desperate to bring in moronic, pliable, corrupt Biden to complete the double-whammy. No way were they going to let little things like the will of the people thwart their plan. Silicon Valley widely censored claims that the election was rigged because it *was* rigged. For the same reason anyone claiming it was rigged was denounced as a 'white supremacist' including the pathetically few Republican politicians willing to say so. Right across the media where the claim was mentioned it was described as a 'false claim' even though these excuses for 'journalists' would have done no research into the subject whatsoever. Trump won seven million more votes than any sitting president had ever achieved while somehow a cognitively-challenged soon to be 78-year-old who was hidden away from the public for most of the campaign managed to win more votes than any presidential candidate in history. It makes no sense. You only had to see election rallies for both candidates to witness the enthusiasm for Trump and the apathy for Biden. Tens of thousands would attend Trump events while Biden was speaking in empty car parks with often only television crews attending and framing their shots to hide the fact that no one was there. It was pathetic to see

footage come to light of Biden standing at a podium making speeches only to TV crews and party fixers while reading the words written for him on massive Teleprompter screens. So, yes, those protestors on January 6th had a point about election rigging, but some were about to walk into a trap laid for them in Washington by the Cult Deep State and its QAnon Psyop. This was the Capitol Hill riot ludicrously dubbed an 'insurrection'.

## **The spider and the fly**

Renegade Minds know there are not two 'sides' in politics, only one side, the Cult, working through all 'sides'. It's a stage show, a puppet show, to direct the perceptions of the population into focusing on diversions like parties and candidates while missing the puppeteers with their hands holding all the strings. The Capitol Hill 'insurrection' brings us back to the Little Big Horn. Having created two distinct opposing groupings – Woke and Pushbackers – the trap was about to be sprung. Pushbackers were to be encircled and isolated by associating them all in the public mind with Trump and then labelling Trump as some sort of Confederate leader. I knew immediately that the Capitol riot was a set-up because of two things. One was how easy the rioters got into the building with virtually no credible resistance and secondly I could see – as with the 'Covid' hoax in the West at the start of 2020 – how the Cult could exploit the situation to move its agenda forward with great speed. My experience of Cult techniques and activities over more than 30 years has showed me that while they do exploit situations they haven't themselves created this never happens with events of fundamental agenda significance. Every time major events giving cultists the excuse to rapidly advance their plan you find they are manipulated into being for the specific reason of providing that excuse – Problem-Reaction-Solution. Only a tiny minority of the huge crowd of Washington protestors sought to gain entry to the Capitol by smashing windows and breaching doors. That didn't matter. The whole crowd and all Pushbackers, even if they did not support Trump, were going to be lumped together as dangerous

insurrectionists and conspiracy theorists. The latter term came into widespread use through a CIA memo in the 1960s aimed at discrediting those questioning the nonsensical official story of the Kennedy assassination and it subsequently became widely employed by the media. It's still being used by inept 'journalists' with no idea of its origin to discredit anyone questioning anything that authority claims to be true. When you are perpetrating a conspiracy you need to discredit the very word itself even though the dictionary definition of conspiracy is merely 'the activity of secretly planning with other people to do something bad or illegal' and 'a general agreement to keep silent about a subject for the purpose of keeping it secret'. On that basis there are conspiracies almost wherever you look. For obvious reasons the Cult and its lapdog media have to claim there are no conspiracies even though the word appears in state laws as with conspiracy to defraud, to murder, and to corrupt public morals.

Agent provocateurs are widely used by the Cult Deep State to manipulate genuine people into acting in ways that suit the desired outcome. By genuine in this case I mean protestors genuinely supporting Trump and claims that the election was stolen. In among them, however, were agents of the state wearing the garb of Trump supporters and QAnon to pump-prime the Capital riot which some genuine Trump supporters naively fell for. I described the situation as 'Come into my parlour said the spider to the fly'. Leaflets appeared through the Woke paramilitary arm Antifa, the anti-fascist fascists, calling on supporters to turn up in Washington looking like Trump supporters even though they hated him. Some of those arrested for breaching the Capitol Building were sourced to Antifa and its stable mate Black Lives Matter. Both organisations are funded by Cult billionaires and corporations. One man charged for the riot was according to his lawyer a former FBI agent who had held top secret security clearance for 40 years. Attorney Thomas Plofchan said of his client, 66-year-old Thomas Edward Caldwell:

He has held a Top Secret Security Clearance since 1979 and has undergone multiple Special Background Investigations in support of his clearances. After retiring from the Navy, he

worked as a section chief for the Federal Bureau of Investigation from 2009-2010 as a GS-12 [mid-level employee].

He also formed and operated a consulting firm performing work, often classified, for U.S government customers including the US Drug Enforcement Agency, Department of Housing and Urban Development, the US Coast Guard, and the US Army Personnel Command.

A judge later released Caldwell pending trial in the absence of evidence about a conspiracy or that he tried to force his way into the building. *The New York Post* reported a 'law enforcement source' as saying that 'at least two known Antifa members were spotted' on camera among Trump supporters during the riot while one of the rioters arrested was John Earle Sullivan, a seriously extreme Black Lives Matter Trump-hater from Utah who was previously arrested and charged in July, 2020, over a BLM-Antifa riot in which drivers were threatened and one was shot. Sullivan is the founder of Utah-based Insurgence USA which is an affiliate of the Cult-created-and-funded Black Lives Matter movement. Footage appeared and was then deleted by Twitter of Trump supporters calling out Antifa infiltrators and a group was filmed changing into pro-Trump clothing before the riot. Security at the building was *pathetic* – as planned. Colonel Leroy Fletcher Prouty, a man with long experience in covert operations working with the US security apparatus, once described the tell-tale sign to identify who is involved in an assassination. He said:

No one has to direct an assassination – it happens. The active role is played secretly by permitting it to happen. This is the greatest single clue. Who has the power to call off or reduce the usual security precautions?

This principle applies to many other situations and certainly to the Capitol riot of January 6th, 2021.

## **The sting**

With such a big and potentially angry crowd known to be gathering near the Capitol the security apparatus would have had a major police detail to defend the building with National Guard troops on

standby given the strength of feeling among people arriving from all over America encouraged by the QAnon Psyop and statements by Donald Trump. Instead Capitol Police 'security' was flimsy, weak, and easily breached. The same number of officers was deployed as on a regular day and that is a blatant red flag. They were not staffed or equipped for a possible riot that had been an obvious possibility in the circumstances. No protective and effective fencing worth the name was put in place and there were no contingency plans. The whole thing was basically a case of standing aside and waving people in. Once inside police mostly backed off apart from one Capitol police officer who ridiculously shot dead unarmed Air Force veteran protestor Ashli Babbitt without a warning as she climbed through a broken window. The 'investigation' refused to name or charge the officer after what must surely be considered a murder in the circumstances. They just lifted a carpet and swept. The story was endlessly repeated about five people dying in the 'armed insurrection' when there was no report of rioters using weapons. Apart from Babbitt the other four died from a heart attack, strokes and apparently a drug overdose. Capitol police officer Brian Sicknick was reported to have died after being bludgeoned with a fire extinguisher when he was alive after the riot was over and died later of what the Washington Medical Examiner's Office said was a stroke. Sicknick had no external injuries. The lies were delivered like rapid fire. There was a narrative to build with incessant repetition of the lie until the lie became the accepted 'everybody knows that' truth. The 'Big Lie' technique of Nazi Propaganda Minister Joseph Goebbels is constantly used by the Cult which was behind the Nazis and is today behind the 'Covid' and 'climate change' hoaxes. Goebbels said:

If you tell a lie big enough and keep repeating it, people will eventually come to believe it. The lie can be maintained only for such time as the State can shield the people from the political, economic and/or military consequences of the lie. It thus becomes vitally important for the State to use all of its powers to repress dissent, for the truth is the mortal enemy of the lie, and thus by extension, the truth is the greatest enemy of the State.



Most protestors had a free run of the Capitol Building. This allowed pictures to be taken of rioters in iconic parts of the building including the Senate chamber which could be used as propaganda images against all Pushbackers. One Congresswoman described the scene as 'the worst kind of non-security anybody could ever imagine'. Well, the first part was true, but someone obviously did imagine it and made sure it happened. Some photographs most widely circulated featured people wearing QAnon symbols and now the Psyop would be used to dub all QAnon followers with the ubiquitous fit-all label of 'white supremacist' and 'insurrectionists'. When a Muslim extremist called Noah Green drove his car at two police officers at the Capitol Building killing one in April, 2021, there was no such political and media hysteria. They were just disappointed he wasn't white.

## **The witch-hunt**

Government prosecutor Michael Sherwin, an aggressive, dark-eyed, professional Rottweiler led the 'investigation' and to call it over the top would be to understate reality a thousand fold. Hundreds were tracked down and arrested for the crime of having the wrong political views and people were jailed who had done nothing more than walk in the building, committed no violence or damage to property, took a few pictures and left. They were labelled a 'threat to the Republic' while Biden sat in the White House signing executive orders written for him that were dismantling 'the Republic'. Even when judges ruled that a mother and son should not be in jail the government kept them there. Some of those arrested have been badly beaten by prison guards in Washington and lawyers for one man said he suffered a fractured skull and was made blind in one eye. Meanwhile a woman is shot dead for no reason by a Capitol Police officer and we are not allowed to know who he is never mind what has happened to him although that will be *nothing*. The Cult's QAnon/Trump sting to identify and isolate Pushbackers and then target them on the road to crushing and deleting them was a resounding success. You would have thought the Russians had

invaded the building at gunpoint and lined up senators for a firing squad to see the political and media reaction. Congresswoman Alexandria Ocasio-Cortez is a child in a woman's body, a terrible-tvos, me, me, me, Woker narcissist of such proportions that words have no meaning. She said she thought she was going to die when 'insurrectionists' banged on her office door. It turned out she wasn't even in the Capitol Building when the riot was happening and the 'banging' was a Capitol Police officer. She referred to herself as a 'survivor' which is an insult to all those true survivors of violent and sexual abuse while she lives her pampered and privileged life talking drivel for a living. Her Woke colleague and fellow mega-narcissist Rashida Tlaib broke down describing the devastating effect on her, too, of *not being* in the building when the rioters were there. Ocasio-Cortez and Tlaib are members of a fully-Woke group of Congresswomen known as 'The Squad' along with Ilhan Omar and Ayanna Pressley. The Squad from what I can see can be identified by its vehement anti-white racism, anti-white men agenda, and, as always in these cases, the absence of brain cells on active duty.

The usual suspects were on the riot case immediately in the form of Democrat ultra-Zionist senators and operatives Chuck Schumer and Adam Schiff demanding that Trump be impeached for 'his part in the insurrection'. The same pair of prats had led the failed impeachment of Trump over the invented 'Russia collusion' nonsense which claimed Russia had helped Trump win the 2016 election. I didn't realise that Tel Aviv had been relocated just outside Moscow. I must find an up-to-date map. The Russia hoax was a Sabbatian operation to keep Trump occupied and impotent and to stop any rapport with Russia which the Cult wants to retain as a perceptual enemy to be pulled out at will. Puppet Biden began attacking Russia when he came to office as the Cult seeks more upheaval, division and war across the world. A two-year stage show 'Russia collusion inquiry' headed by the not-very-bright former 9/11 FBI chief Robert Mueller, with support from 19 lawyers, 40 FBI agents plus intelligence analysts, forensic accountants and other

staff, devoured tens of millions of dollars and found no evidence of Russia collusion which a ten-year-old could have told them on day one. Now the same moronic Schumer and Schiff wanted a second impeachment of Trump over the Capitol 'insurrection' (riot) which the arrested development of Schumer called another 'Pearl Harbor' while others compared it with 9/11 in which 3,000 died and, in the case of CNN, with the Rwandan genocide in the 1990s in which an estimated 500,000 to 600,000 were murdered, between 250,000 and 500,000 women were raped, and populations of whole towns were hacked to death with machetes. To make those comparisons purely for Cult political reasons is beyond insulting to those that suffered and lost their lives and confirms yet again the callous inhumanity that we are dealing with. Schumer is a monumental idiot and so is Schiff, but they serve the Cult agenda and do whatever they're told so they get looked after. Talking of idiots – another inane man who spanned the Russia and Capitol impeachment attempts was Senator Eric Swalwell who had the nerve to accuse Trump of collusion with the Russians while sleeping with a Chinese spy called Christine Fang or 'Fang Fang' which is straight out of a Bond film no doubt starring Klaus Schwab as the bloke living on a secret island and controlling laser weapons positioned in space and pointing at world capitals. Fang Fang plays the part of Bond's infiltrator girlfriend which I'm sure she would enjoy rather more than sharing a bed with the brainless Swalwell, lying back and thinking of China. The FBI eventually warned Swalwell about Fang Fang which gave her time to escape back to the Chinese dictatorship. How very thoughtful of them. The second Trump impeachment also failed and hardly surprising when an impeachment is supposed to remove a sitting president and by the time it happened Trump was no longer president. These people are running your country America, well, officially anyway. Terrifying isn't it?

### **Outcomes tell the story - always**

The outcome of all this – and it's the *outcome* on which Renegade Minds focus, not the words – was that a vicious, hysterical and

obviously pre-planned assault was launched on Pushbackers to censor, silence and discredit them and even targeted their right to earn a living. They have since been condemned as 'domestic terrorists' that need to be treated like Al-Qaeda and Islamic State. 'Domestic terrorists' is a label the Cult has been trying to make stick since the period of the Oklahoma bombing in 1995 which was blamed on 'far-right domestic terrorists'. If you read *The Trigger* you will see that the bombing was clearly a Problem-Reaction-Solution carried out by the Deep State during a Bill Clinton administration so corrupt that no dictionary definition of the term would even nearly suffice. Nearly 30, 000 troops were deployed from all over America to the empty streets of Washington for Biden's inauguration. Ten thousand of them stayed on with the pretext of protecting the capital from insurrectionists when it was more psychological programming to normalise the use of the military in domestic law enforcement in support of the Cult plan for a police-military state. Biden's fascist administration began a purge of 'wrong-thinkers' in the military which means anyone that is not on board with Woke. The Capitol Building was surrounded by a fence with razor wire and the Land of the Free was further symbolically and literally dismantled. The circle was completed with the installation of Biden and the exploitation of the QAnon Psyop.

America had never been so divided since the civil war of the 19th century, Pushbackers were isolated and dubbed terrorists and now, as was always going to happen, the Cult immediately set about deleting what little was left of freedom and transforming American society through a swish of the hand of the most controlled 'president' in American history leading (officially at least) the most extreme regime since the country was declared an independent state on July 4th, 1776. Biden issued undebated, dictatorial executive orders almost by the hour in his opening days in office across the whole spectrum of the Cult wish-list including diluting controls on the border with Mexico allowing thousands of migrants to illegally enter the United States to transform the demographics of America and import an election-changing number of perceived Democrat

voters. Then there were Biden deportation amnesties for the already illegally resident (estimated to be as high as 20 or even 30 million). A bill before Congress awarded American citizenship to anyone who could prove they had worked in agriculture for just 180 days in the previous two years as 'Big Ag' secured its slave labour long-term. There were the plans to add new states to the union such as Puerto Rico and making Washington DC a state. They are all parts of a plan to ensure that the Cult-owned Woke Democrats would be permanently in power.

### **Border – what border?**

I have exposed in detail in other books how mass immigration into the United States and Europe is the work of Cult networks fuelled by the tens of billions spent to this and other ends by George Soros and his global Open Society (open borders) Foundations. The impact can be seen in America alone where the population has increased by *100 million* in little more than 30 years mostly through immigration. I wrote in *The Answer* that the plan was to have so many people crossing the southern border that the numbers become unstoppable and we are now there under Cult-owned Biden. El Salvador in Central America puts the scale of what is happening into context. A third of the population now lives in the United States, much of it illegally, and many more are on the way. The methodology is to crush Central and South American countries economically and spread violence through machete-wielding psychopathic gangs like MS-13 based in El Salvador and now operating in many American cities. Biden-imposed lax security at the southern border means that it is all but open. He said before his 'election' that he wanted to see a surge towards the border if he became president and that was the green light for people to do just that after election day to create the human disaster that followed for both America and the migrants. When that surge came the imbecilic Alexandria Ocasio-Cortez said it wasn't a 'surge' because they are 'children, not insurgents' and the term 'surge' (used by Biden) was a claim of 'white supremacists'.

This disingenuous lady may one day enter the realm of the most basic intelligence, but it won't be any time soon.

Sabbatians and the Cult are in the process of destroying America by importing violent people and gangs in among the genuine to terrorise American cities and by overwhelming services that cannot cope with the sheer volume of new arrivals. Something similar is happening in Europe as Western society in general is targeted for demographic and cultural transformation and upheaval. The plan demands violence and crime to create an environment of intimidation, fear and division and Soros has been funding the election of district attorneys across America who then stop prosecuting many crimes, reduce sentences for violent crimes and free as many violent criminals as they can. Sabbatians are creating the chaos from which order – their order – can respond in a classic Problem-Reaction-Solution. A Freemasonic motto says 'Ordo Ab Chao' (Order out of Chaos) and this is why the Cult is constantly creating chaos to impose a new 'order'. Here you have the reason the Cult is constantly creating chaos. The 'Covid' hoax can be seen with those entering the United States by plane being forced to take a 'Covid' test while migrants flooding through southern border processing facilities do not. Nothing is put in the way of mass migration and if that means ignoring the government's own 'Covid' rules then so be it. They know it's all bullshit anyway. Any pushback on this is denounced as 'racist' by Wokers and Sabbatian fronts like the ultra-Zionist Anti-Defamation League headed by the appalling Jonathan Greenblatt which at the same time argues that Israel should not give citizenship and voting rights to more Palestinian Arabs or the 'Jewish population' (in truth the Sabbatian network) will lose control of the country.

### **Society-changing numbers**

Biden's masters have declared that countries like El Salvador are so dangerous that their people must be allowed into the United States for humanitarian reasons when there are fewer murders in large parts of many Central American countries than in US cities like

Baltimore. That is not to say Central America cannot be a dangerous place and Cult-controlled American governments have been making it so since way back, along with the dismantling of economies, in a long-term plan to drive people north into the United States. Parts of Central America are very dangerous, but in other areas the story is being greatly exaggerated to justify relaxing immigration criteria. Migrants are being offered free healthcare and education in the United States as another incentive to head for the border and there is no requirement to be financially independent before you can enter to prevent the resources of America being drained. You can't blame migrants for seeking what they believe will be a better life, but they are being played by the Cult for dark and nefarious ends. The numbers since Biden took office are huge. In February, 2021, more than 100,000 people were known to have tried to enter the US illegally through the southern border (it was 34,000 in the same month in 2020) and in March it was 170,000 – a 418 percent increase on March, 2020. These numbers are only known people, not the ones who get in unseen. The true figure for migrants illegally crossing the border in a single month was estimated by one congressman at 250,000 and that number will only rise under Biden's current policy. Gangs of murdering drug-running thugs that control the Mexican side of the border demand money – thousands of dollars – to let migrants cross the Rio Grande into America. At the same time gun battles are breaking out on the border several times a week between rival Mexican drug gangs (which now operate globally) who are equipped with sophisticated military-grade weapons, grenades and armoured vehicles. While the Capitol Building was being 'protected' from a non-existent 'threat' by thousands of troops, and others were still deployed at the time in the Cult Neocon war in Afghanistan, the southern border of America was left to its fate. This is not incompetence, it is cold calculation.

By March, 2021, there were 17,000 unaccompanied children held at border facilities and many of them are ensnared by people traffickers for paedophile rings and raped on their journey north to America. This is not conjecture – this is fact. Many of those designated

children are in reality teenage boys or older. Meanwhile Wokers posture their self-purity for encouraging poor and tragic people to come to America and face this nightmare both on the journey and at the border with the disgusting figure of House Speaker Nancy Pelosi giving disingenuous speeches about caring for migrants. The woman's evil. Wokers condemned Trump for having children in cages at the border (so did Obama, *Shhhh*), but now they are sleeping on the floor without access to a shower with one border facility 729 percent over capacity. The Biden insanity even proposed flying migrants from the southern border to the northern border with Canada for 'processing'. The whole shambles is being overseen by ultra-Zionist Secretary of Homeland Security, the moronic liar Alejandro Mayorkas, who banned news cameras at border facilities to stop Americans seeing what was happening. Mayorkas said there was not a ban on news crews; it was just that they were not allowed to film. Alongside him at Homeland Security is another ultra-Zionist Cass Sunstein appointed by Biden to oversee new immigration laws. Sunstein despises conspiracy researchers to the point where he suggests they should be banned or *taxed* for having such views. The man is not bonkers or anything. He's perfectly well-adjusted, but adjusted to what is the question. Criticise what is happening and you are a 'white supremacist' when earlier non-white immigrants also oppose the numbers which effect their lives and opportunities. Black people in poor areas are particularly damaged by uncontrolled immigration and the increased competition for work opportunities with those who will work for less. They are also losing voting power as Hispanics become more dominant in former black areas. It's a downward spiral for them while the billionaires behind the policy drone on about how much they care about black people and 'racism'. None of this is about compassion for migrants or black people – that's just wind and air. Migrants are instead being mercilessly exploited to transform America while the countries they leave are losing their future and the same is true in Europe. Mass immigration may now be the work of Woke Democrats, but it can be traced back to the 1986 Immigration Reform and Control Act (it



wasn't) signed into law by Republican hero President Ronald Reagan which gave amnesty to millions living in the United States illegally and other incentives for people to head for the southern border. Here we have the one-party state at work again.

## **Save me syndrome**

Almost every aspect of what I have been exposing as the Cult agenda was on display in even the first days of 'Biden' with silencing of Pushbackers at the forefront of everything. A Renegade Mind will view the Trump years and QAnon in a very different light to their supporters and advocates as the dots are connected. The QAnon/Trump Psyop has given the Cult all it was looking for. We may not know how much, or little, that Trump realised he was being used, but that's a side issue. This pincer movement produced the desired outcome of dividing America and having Pushbackers isolated. To turn this around we have to look at new routes to empowerment which do not include handing our power to other people and groups through what I will call the 'Save Me Syndrome' – 'I want someone else to do it so that I don't have to'. We have seen this at work throughout human history and the QAnon/Trump Psyop is only the latest incarnation alongside all the others. Religion is an obvious expression of this when people look to a 'god' or priest to save them or tell them how to be saved and then there are 'save me' politicians like Trump. Politics is a diversion and not a 'saviour'. It is a means to block positive change, not make it possible.

Save Me Syndrome always comes with the same repeating theme of handing your power to whom or what you believe will save you while your real 'saviour' stares back from the mirror every morning. Renegade Minds are constantly vigilant in this regard and always asking the question 'What can I do?' rather than 'What can someone else do for me?' Gandhi was right when he said: 'You must be the change you want to see in the world.' We are indeed the people we have been waiting for. We are presented with a constant raft of reasons to concede that power to others and forget where the real power is. Humanity has the numbers and the Cult does not. It has to

use diversion and division to target the unstoppable power that comes from unity. Religions, governments, politicians, corporations, media, QAnon, are all different manifestations of this power-diversion and dilution. Refusing to give your power to governments and instead handing it to Trump and QAnon is not to take a new direction, but merely to recycle the old one with new names on the posters. I will explore this phenomenon as we proceed and how to break the cycles and recycles that got us here through the mists of repeating perception and so repeating history.

For now we shall turn to the most potent example in the entire human story of the consequences that follow when you give your power away. I am talking, of course, of the 'Covid' hoax.

## CHAPTER FOUR

### **'Covid': Calculated catastrophe**

*Facts are threatening to those invested in fraud*  
DaShanne Stokes

**W**e can easily unravel the real reason for the 'Covid pandemic' hoax by employing the Renegade Mind methodology that I have outlined this far. We'll start by comparing the long-planned Cult outcome with the 'Covid pandemic' outcome. Know the outcome and you'll see the journey.

I have highlighted the plan for the Hunger Games Society which has been in my books for so many years with the very few controlling the very many through ongoing dependency. To create this dependency it is essential to destroy independent livelihoods, businesses and employment to make the population reliant on the state (the Cult) for even the basics of life through a guaranteed pittance income. While independence of income remained these Cult ambitions would be thwarted. With this knowledge it was easy to see where the 'pandemic' hoax was going once talk of 'lockdowns' began and the closing of all but perceived 'essential' businesses to 'save' us from an alleged 'deadly virus'. Cult corporations like Amazon and Walmart were naturally considered 'essential' while mom and pop shops and stores had their doors closed by fascist decree. As a result with every new lockdown and new regulation more small and medium, even large businesses not owned by the Cult, went to the wall while Cult giants and their frontmen and women grew financially fatter by the second. Mom and pop were

denied an income and the right to earn a living and the wealth of people like Jeff Bezos (Amazon), Mark Zuckerberg (Facebook) and Sergei Brin and Larry Page (Google/Alphabet) have reached record levels. The Cult was increasing its own power through further dramatic concentrations of wealth while the competition was being destroyed and brought into a state of dependency. Lockdowns have been instigated to secure that very end and were never anything to do with health. My brother Paul spent 45 years building up a bus repair business, but lockdowns meant buses were running at a fraction of normal levels for months on end. Similar stories can be told in their hundreds of millions worldwide. Efforts of a lifetime coldly destroyed by Cult multi-billionaires and their lackeys in government and law enforcement who continued to earn their living from the taxation of the people while denying the right of the same people to earn theirs. How different it would have been if those making and enforcing these decisions had to face the same financial hardships of those they affected, but they never do.

## **Gates of Hell**

Behind it all in the full knowledge of what he is doing and why is the psychopathic figure of Cult operative Bill Gates. His puppet Tedros at the World Health Organization declared 'Covid' a pandemic in March, 2020. The WHO had changed the definition of a 'pandemic' in 2009 just a month before declaring the 'swine flu pandemic' which would not have been so under the previous definition. The same applies to 'Covid'. The definition had included... 'an infection by an infectious agent, occurring simultaneously in different countries, with a significant mortality rate relative to the proportion of the population infected'. The new definition removed the need for 'significant mortality'. The 'pandemic' has been fraudulent even down to the definition, but Gates demanded economy-destroying lockdowns, school closures, social distancing, mandatory masks, a 'vaccination' for every man, woman and child on the planet and severe consequences and restrictions for those that refused. Who gave him this power? The

Cult did which he serves like a little boy in short trousers doing what his daddy tells him. He and his psychopathic missus even smiled when they said that much worse was to come (what they knew was planned to come). Gates responded in the matter-of-fact way of all psychopaths to a question about the effect on the world economy of what he was doing:

Well, it won't go to zero but it will shrink. Global GDP is probably going to take the biggest hit ever [Gates was smiling as he said this] ... in my lifetime this will be the greatest economic hit. But you don't have a choice. People act as if you have a choice. People don't feel like going to the stadium when they might get infected ... People are deeply affected by seeing these stats, by knowing they could be part of the transmission chain, old people, their parents and grandparents, could be affected by this, and so you don't get to say ignore what is going on here.

There will be the ability to open up, particularly in rich countries, if things are done well over the next few months, but for the world at large normalcy only returns when we have largely vaccinated the entire population.

The man has no compassion or empathy. How could he when he's a psychopath like all Cult players? My own view is that even beyond that he is very seriously mentally ill. Look in his eyes and you can see this along with his crazy flailing arms. You don't do what he has done to the world population since the start of 2020 unless you are mentally ill and at the most extreme end of psychopathic. You especially don't do it when to you know, as we shall see, that cases and deaths from 'Covid' are fakery and a product of monumental figure massaging. 'These stats' that Gates referred to are based on a 'test' that's not testing for the 'virus' as he has known all along. He made his fortune with big Cult support as an infamously ruthless software salesman and now buys global control of 'health' (death) policy without the population he affects having any say. It's a breathtaking outrage. Gates talked about people being deeply affected by fear of 'Covid' when that was because of *him* and his global network lying to them minute-by-minute supported by a lying media that he seriously influences and funds to the tune of hundreds of millions. He's handed big sums to media operations including the BBC, NBC, Al Jazeera, Univision, *PBS NewsHour*,

*ProPublica, National Journal, The Guardian, The Financial Times, The Atlantic, Texas Tribune, USA Today publisher Gannett, Washington Monthly, Le Monde, Center for Investigative Reporting, Pulitzer Center on Crisis Reporting, National Press Foundation, International Center for Journalists, Solutions Journalism Network, the Poynter Institute for Media Studies, and many more. Gates is everywhere in the 'Covid' hoax and the man must go to prison – or a mental facility – for the rest of his life and his money distributed to those he has taken such enormous psychopathic pleasure in crushing.*

## **The Muscle**

The Hunger Games global structure demands a police-military state – a fusion of the two into one force – which viciously imposes the will of the Cult on the population and protects the Cult from public rebellion. In that regard, too, the 'Covid' hoax just keeps on giving. Often unlawful, ridiculous and contradictory 'Covid' rules and regulations have been policed across the world by moronic automatons and psychopaths made faceless by face-nappy masks and acting like the Nazi SS and fascist blackshirts and brownshirts of Hitler and Mussolini. The smallest departure from the rules decreed by the psychos in government and their clueless gofers were jumped upon by the face-nappy fascists. Brutality against public protestors soon became commonplace even on girls, women and old people as the brave men with the batons – the Face-Nappies as I call them – broke up peaceful protests and handed out fines like confetti to people who couldn't earn a living let alone pay hundreds of pounds for what was once an accepted human right. Robot Face-Nappies of Nottingham police in the English East Midlands fined one group £11,000 for attending a child's birthday party. For decades I charted the transformation of law enforcement as genuine, decent officers were replaced with psychopaths and the brain dead who would happily and brutally do whatever their masters told them. Now they were let loose on the public and I would emphasise the point that none of this just happened. The step-by-step change in the dynamic between police and public was orchestrated from the shadows by

those who knew where this was all going and the same with the perceptual reframing of those in all levels of authority and official administration through 'training courses' by organisations such as Common Purpose which was created in the late 1980s and given a massive boost in Blair era Britain until it became a global phenomenon. Supposed public 'servants' began to view the population as the enemy and the same was true of the police. This was the start of the explosion of behaviour manipulation organisations and networks preparing for the all-war on the human psyche unleashed with the dawn of 2020. I will go into more detail about this later in the book because it is a core part of what is happening.

Police desecrated beauty spots to deter people gathering and arrested women for walking in the countryside alone 'too far' from their homes. We had arrogant, clueless sergeants in the Isle of Wight police where I live posting on Facebook what they insisted the population must do or else. A schoolmaster sergeant called Radford looked young enough for me to ask if his mother knew he was out, but he was posting what he *expected* people to do while a Sergeant Wilkinson boasted about fining lads for meeting in a McDonald's car park where they went to get a lockdown takeaway. Wilkinson added that he had even cancelled their order. What a pair of prats these people are and yet they have increasingly become the norm among Jackboot Johnson's Yellowshirts once known as the British police. This was the theme all over the world with police savagery common during lockdown protests in the United States, the Netherlands, and the fascist state of Victoria in Australia under its tyrannical and again moronic premier Daniel Andrews. Amazing how tyrannical and moronic tend to work as a team and the same combination could be seen across America as arrogant, narcissistic Woke governors and mayors such as Gavin Newsom (California), Andrew Cuomo (New York), Gretchen Whitmer (Michigan), Lori Lightfoot (Chicago) and Eric Garcetti (Los Angeles) did their Nazi and Stalin impressions with the full support of the compliant brutality of their enforcers in uniform as they arrested small business owners defying

fascist shutdown orders and took them to jail in ankle shackles and handcuffs. This happened to bistro owner Marlena Pavlos-Hackney in Gretchen Whitmer's fascist state of Michigan when police arrived to enforce an order by a state-owned judge for 'putting the community at risk' at a time when other states like Texas were dropping restrictions and migrants were pouring across the southern border without any 'Covid' questions at all. I'm sure there are many officers appalled by what they are ordered to do, but not nearly enough of them. If they were truly appalled they would not do it. As the months passed every opportunity was taken to have the military involved to make their presence on the streets ever more familiar and 'normal' for the longer-term goal of police-military fusion.

Another crucial element to the Hunger Games enforcement network has been encouraging the public to report neighbours and others for 'breaking the lockdown rules'. The group faced with £11,000 in fines at the child's birthday party would have been dobbed-in by a neighbour with a brain the size of a pea. The technique was most famously employed by the Stasi secret police in communist East Germany who had public informants placed throughout the population. A police chief in the UK says his force doesn't need to carry out 'Covid' patrols when they are flooded with so many calls from the public reporting other people for visiting the beach. Dorset police chief James Vaughan said people were so enthusiastic about snitching on their fellow humans they were now operating as an auxiliary arm of the police: 'We are still getting around 400 reports a week from the public, so we will respond to reports ... We won't need to be doing hotspot patrols because people are very quick to pick the phone up and tell us.' Vaughan didn't say that this is a pillar of all tyrannies of whatever complexion and the means to hugely extend the reach of enforcement while spreading distrust among the people and making them wary of doing anything that might get them reported. Those narcissistic Isle of Wight sergeants Radford and Wilkinson never fail to add a link to their Facebook posts where the public can inform on their fellow slaves.



Neither would be self-aware enough to realise they were imitating the Stasi which they might well never have heard of. Government psychologists that I will expose later laid out a policy to turn communities against each other in the same way.

### **A coincidence? Yep, and I can knit fog**

I knew from the start of the alleged pandemic that this was a Cult operation. It presented limitless potential to rapidly advance the Cult agenda and exploit manipulated fear to demand that every man, woman and child on the planet was 'vaccinated' in a process never used on humans before which infuses self-replicating *synthetic* material into human cells. Remember the plan to transform the human body from a biological to a synthetic biological state. I'll deal with the 'vaccine' (that's not actually a vaccine) when I focus on the genetic agenda. Enough to say here that mass global 'vaccination' justified by this 'new virus' set alarms ringing after 30 years of tracking these people and their methods. The 'Covid' hoax officially beginning in China was also a big red flag for reasons I will be explaining. The agenda potential was so enormous that I could dismiss any idea that the 'virus' appeared naturally. Major happenings with major agenda implications never occur without Cult involvement in making them happen. My questions were twofold in early 2020 as the media began its campaign to induce global fear and hysteria: Was this alleged infectious agent released on purpose by the Cult or did it even exist at all? I then did what I always do in these situations. I sat, observed and waited to see where the evidence and information would take me. By March and early April synchronicity was strongly – and ever more so since then – pointing me in the direction of *there is no 'virus'*. I went public on that with derision even from swathes of the alternative media that voiced a scenario that the Chinese government released the 'virus' in league with Deep State elements in the United States from a top-level bio-lab in Wuhan where the 'virus' is said to have first appeared. I looked at that possibility, but I didn't buy it for several reasons. Deaths from the 'virus' did not in any way match what they

would have been with a 'deadly bioweapon' and it is much more effective if you sell the *illusion* of an infectious agent rather than having a real one unless you can control through injection who has it and who doesn't. Otherwise you lose control of events. A made-up 'virus' gives you a blank sheet of paper on which you can make it do whatever you like and have any symptoms or mutant 'variants' you choose to add while a real infectious agent would limit you to what it actually does. A phantom disease allows you to have endless ludicrous 'studies' on the 'Covid' dollar to widen the perceived impact by inventing ever more 'at risk' groups including one study which said those who walk slowly may be almost four times more likely to die from the 'virus'. People are in psychiatric wards for less.

A real 'deadly bioweapon' can take out people in the hierarchy that are not part of the Cult, but essential to its operation. Obviously they don't want that. Releasing a real disease means you immediately lose control of it. Releasing an illusory one means you don't. Again it's vital that people are extra careful when dealing with what they want to hear. A bioweapon unleashed from a Chinese laboratory in collusion with the American Deep State may fit a conspiracy narrative, but is it true? Would it not be far more effective to use the excuse of a 'virus' to justify the real bioweapon – the 'vaccine'? That way your disease agent does not have to be transmitted and arrives directly through a syringe. I saw a French virologist Luc Montagnier quoted in the alternative media as saying he had discovered that the alleged 'new' severe acute respiratory syndrome coronavirus , or SARS-CoV-2, was made artificially and included elements of the human immunodeficiency 'virus' (HIV) and a parasite that causes malaria. SARS-CoV-2 is alleged to trigger an alleged illness called Covid-19. I remembered Montagnier's name from my research years before into claims that an HIV 'retrovirus' causes AIDs – claims that were demolished by Berkeley virologist Peter Duesberg who showed that no one had ever proved that HIV causes acquired immunodeficiency syndrome or AIDS. Claims that become accepted as fact, publicly and medically, with no proof whatsoever are an ever-recurring story that profoundly applies to

'Covid'. Nevertheless, despite the lack of proof, Montagnier's team at the Pasteur Institute in Paris had a long dispute with American researcher Robert Gallo over which of them discovered and isolated the HIV 'virus' and with *no evidence* found it to cause AIDS. You will see later that there is also no evidence that any 'virus' causes any disease or that there is even such a thing as a 'virus' in the way it is said to exist. The claim to have 'isolated' the HIV 'virus' will be presented in its real context as we come to the shocking story – and it is a story – of SARS-CoV-2 and so will Montagnier's assertion that he identified the full SARS-CoV-2 genome.

### **Hoax in the making**

We can pick up the 'Covid' story in 2010 and the publication by the Rockefeller Foundation of a document called 'Scenarios for the Future of Technology and International Development'. The inner circle of the Rockefeller family has been serving the Cult since John D. Rockefeller (1839-1937) made his fortune with Standard Oil. It is less well known that the same Rockefeller – the Bill Gates of his day – was responsible for establishing what is now referred to as 'Big Pharma', the global network of pharmaceutical companies that make outrageous profits dispensing scalpel and drug 'medicine' and are obsessed with pumping vaccines in ever-increasing number into as many human arms and backsides as possible. John D. Rockefeller was the driving force behind the creation of the 'education' system in the United States and elsewhere specifically designed to program the perceptions of generations thereafter. The Rockefeller family donated exceptionally valuable land in New York for the United Nations building and were central in establishing the World Health Organization in 1948 as an agency of the UN which was created from the start as a Trojan horse and stalking horse for world government. Now enter Bill Gates. His family and the Rockefellers have long been extremely close and I have seen genealogy which claims that if you go back far enough the two families fuse into the same bloodline. Gates has said that the Bill and Melinda Gates Foundation was inspired by the Rockefeller Foundation and why not

when both are serving the same Cult? Major tax-exempt foundations are overwhelmingly criminal enterprises in which Cult assets fund the Cult agenda in the guise of 'philanthropy' while avoiding tax in the process. Cult operatives can become mega-rich in their role of front men and women for the psychopaths at the inner core and they, too, have to be psychopaths to knowingly serve such evil. Part of the deal is that a big percentage of the wealth gleaned from representing the Cult has to be spent advancing the ambitions of the Cult and hence you have the Rockefeller Foundation, Bill and Melinda Gates Foundation (and *so* many more) and people like George Soros with his global Open Society Foundations spending their billions in pursuit of global Cult control. Gates is a global public face of the Cult with his interventions in world affairs including Big Tech influence; a central role in the 'Covid' and 'vaccine' scam; promotion of the climate change shakedown; manipulation of education; geoengineering of the skies; and his food-control agenda as the biggest owner of farmland in America, his GMO promotion and through other means. As one writer said: 'Gates monopolizes or wields disproportionate influence over the tech industry, global health and vaccines, agriculture and food policy (including biopiracy and fake food), weather modification and other climate technologies, surveillance, education and media.' The almost limitless wealth secured through Microsoft and other not-allowed-to-fail ventures (including vaccines) has been ploughed into a long, long list of Cult projects designed to enslave the entire human race. Gates and the Rockefellers have been working as one unit with the Rockefeller-established World Health Organization leading global 'Covid' policy controlled by Gates through his mouth-piece Tedros. Gates became the WHO's biggest funder when Trump announced that the American government would cease its donations, but Biden immediately said he would restore the money when he took office in January, 2021. The Gates Foundation (the Cult) owns through limitless funding the world health system and the major players across the globe in the 'Covid' hoax.

Okay, with that background we return to that Rockefeller Foundation document of 2010 headed 'Scenarios for the Future of Technology and International Development' and its 'imaginary' epidemic of a virulent and deadly influenza strain which infected 20 percent of the global population and killed eight million in seven months. The Rockefeller scenario was that the epidemic destroyed economies, closed shops, offices and other businesses and led to governments imposing fierce rules and restrictions that included mandatory wearing of face masks and body-temperature checks to enter communal spaces like railway stations and supermarkets. The document predicted that even after the height of the Rockefeller-envisaged epidemic the authoritarian rule would continue to deal with further pandemics, transnational terrorism, environmental crises and rising poverty. Now you may think that the Rockefellers are our modern-day seers or alternatively, and rather more likely, that they well knew what was planned a few years further on. Fascism had to be imposed, you see, to 'protect citizens from risk and exposure'. The Rockefeller scenario document said:

During the pandemic, national leaders around the world flexed their authority and imposed airtight rules and restrictions, from the mandatory wearing of face masks to body-temperature checks at the entries to communal spaces like train stations and supermarkets. Even after the pandemic faded, this more authoritarian control and oversight of citizens and their activities stuck and even intensified. In order to protect themselves from the spread of increasingly global problems – from pandemics and transnational terrorism to environmental crises and rising poverty – leaders around the world took a firmer grip on power.

At first, the notion of a more controlled world gained wide acceptance and approval. Citizens willingly gave up some of their sovereignty – and their privacy – to more paternalistic states in exchange for greater safety and stability. Citizens were more tolerant, and even eager, for top-down direction and oversight, and national leaders had more latitude to impose order in the ways they saw fit.

In developed countries, this heightened oversight took many forms: biometric IDs for all citizens, for example, and tighter regulation of key industries whose stability was deemed vital to national interests. In many developed countries, enforced cooperation with a suite of new regulations and agreements slowly but steadily restored both order and, importantly, economic growth.

There we have the prophetic Rockefellers in 2010 and three years later came their paper for the Global Health Summit in Beijing, China, when government representatives, the private sector, international organisations and groups met to discuss the next 100 years of 'global health'. The Rockefeller Foundation-funded paper was called 'Dreaming the Future of Health for the Next 100 Years and more prophecy ensued as it described a dystopian future: 'The abundance of data, digitally tracking and linking people may mean the 'death of privacy' and may replace physical interaction with transient, virtual connection, generating isolation and raising questions of how values are shaped in virtual networks.' Next in the 'Covid' hoax preparation sequence came a 'table top' simulation in 2018 for another 'imaginary' pandemic of a disease called Clade X which was said to kill 900 million people. The exercise was organised by the Gates-funded Johns Hopkins University's Center for Health Security in the United States and this is the very same university that has been compiling the disgustingly and systematically erroneous global figures for 'Covid' cases and deaths. Similar Johns Hopkins health crisis scenarios have included the Dark Winter exercise in 2001 and Atlantic Storm in 2005.

## **Nostradamus 201**

For sheer predictive genius look no further prophecy-watchers than the Bill Gates-funded Event 201 held only six weeks before the 'coronavirus pandemic' is supposed to have broken out in China and Event 201 was based on a scenario of a global 'coronavirus pandemic'. Melinda Gates, the great man's missus, told the BBC that he had 'prepared for years' for a coronavirus pandemic which told us what we already knew. Nostradamugates had predicted in a TED talk in 2015 that a pandemic was coming that would kill a lot of people and demolish the world economy. My god, the man is a machine – possibly even literally. Now here he was only weeks before the real thing funding just such a simulated scenario and involving his friends and associates at Johns Hopkins, the World Economic Forum Cult-front of Klaus Schwab, the United Nations,

Johnson & Johnson, major banks, and officials from China and the Centers for Disease Control in the United States. What synchronicity – Johns Hopkins would go on to compile the fraudulent ‘Covid’ figures, the World Economic Forum and Schwab would push the ‘Great Reset’ in response to ‘Covid’, the Centers for Disease Control would be at the forefront of ‘Covid’ policy in the United States, Johnson & Johnson would produce a ‘Covid vaccine’, and everything would officially start just weeks later in China. Spooky, eh? They were even accurate in creating a simulation of a ‘virus’ pandemic because the ‘real thing’ would also be a simulation. Event 201 was not an exercise preparing for something that might happen; it was a rehearsal for what those in control knew was *going* to happen and very shortly. Hours of this simulation were posted on the Internet and the various themes and responses mirrored what would soon be imposed to transform human society. News stories were inserted and what they said would be commonplace a few weeks later with still more prophecy perfection. Much discussion focused on the need to deal with misinformation and the ‘anti-vax movement’ which is exactly what happened when the ‘virus’ arrived – was said to have arrived – in the West.

Cult-owned social media banned criticism and exposure of the official ‘virus’ narrative and when I said there *was* no ‘virus’ in early April, 2020, I was banned by one platform after another including YouTube, Facebook and later Twitter. The mainstream broadcast media in Britain was in effect banned from interviewing me by the Tony-Blair-created government broadcasting censor Ofcom headed by career government bureaucrat Melanie Dawes who was appointed just as the ‘virus’ hoax was about to play out in January, 2020. At the same time the Ickonic media platform was using Vimeo, another ultra-Zionist-owned operation, while our own player was being created and they deleted in an instant hundreds of videos, documentaries, series and shows to confirm their unbelievable vindictiveness. We had copies, of course, and they had to be restored one by one when our player was ready. These people have no class. Sabbatian Facebook promised free advertisements for the Gates-

controlled World Health Organization narrative while deleting ‘false claims and conspiracy theories’ to stop ‘misinformation’ about the alleged coronavirus. All these responses could be seen just a short while earlier in the scenarios of Event 201. Extreme censorship was absolutely crucial for the Cult because the official story was so ridiculous and unsupportable by the evidence that it could never survive open debate and the free-flow of information and opinion. If you can’t win a debate then don’t have one is the Cult’s approach throughout history. Facebook’s little boy front man – front boy – Mark Zuckerberg equated ‘credible and accurate information’ with official sources and exposing their lies with ‘misinformation’.

### **Silencing those that can see**

The censorship dynamic of Event 201 is now the norm with an army of narrative-supporting ‘fact-checker’ organisations whose entire reason for being is to tell the public that official narratives are true and those exposing them are lying. One of the most appalling of these ‘fact-checkers’ is called NewsGuard founded by ultra-Zionist Americans Gordon Crovitz and Steven Brill. Crovitz is a former publisher of *The Wall Street Journal*, former Executive Vice President of Dow Jones, a member of the Council on Foreign Relations (CFR), and on the board of the American Association of Rhodes Scholars. The CFR and Rhodes Scholarships, named after Rothschild agent Cecil Rhodes who plundered the gold and diamonds of South Africa for his masters and the Cult, have featured widely in my books. NewsGuard don’t seem to like me for some reason – I really can’t think why – and they have done all they can to have me censored and discredited which is, to quote an old British politician, like being savaged by a dead sheep. They are, however, like all in the censorship network, very well connected and funded by organisations themselves funded by, or connected to, Bill Gates. As you would expect with anything associated with Gates NewsGuard has an offshoot called HealthGuard which ‘fights online health care hoaxes’. How very kind. Somehow the NewsGuard European Managing Director Anna-Sophie Harling, a remarkably young-



looking woman with no broadcasting experience and little hands-on work in journalism, has somehow secured a position on the 'Content Board' of UK government broadcast censor Ofcom. An executive of an organisation seeking to discredit dissidents of the official narratives is making decisions for the government broadcast 'regulator' about content?? Another appalling 'fact-checker' is Full Fact funded by George Soros and global censors Google and Facebook.

It's amazing how many activists in the 'fact-checking', 'anti-hate', arena turn up in government-related positions – people like UK Labour Party activist Imran Ahmed who heads the Center for Countering Digital Hate founded by people like Morgan McSweeney, now chief of staff to the Labour Party's hapless and useless 'leader' Keir Starmer. Digital Hate – which is what it really is – uses the American spelling of Center to betray its connection to a transatlantic network of similar organisations which in 2020 shapeshifted from attacking people for 'hate' to attacking them for questioning the 'Covid' hoax and the dangers of the 'Covid vaccine'. It's just a coincidence, you understand. This is one of Imran Ahmed's hysterical statements: 'I would go beyond calling anti-vaxxers conspiracy theorists to say they are an extremist group that pose a national security risk.' No one could ever accuse this prat of understatement and he's including in that those parents who are now against vaccines after their children were damaged for life or killed by them. He's such a nice man. Ahmed does the rounds of the Woke media getting soft-ball questions from spineless 'journalists' who never ask what right he has to campaign to destroy the freedom of speech of others while he demands it for himself. There also seems to be an overrepresentation in Ofcom of people connected to the narrative-worshipping BBC. This incredible global network of narrative-support was super-vital when the 'Covid' hoax was played in the light of the mega-whopper lies that have to be defended from the spotlight cast by the most basic intelligence.

## **Setting the scene**

The Cult plays the long game and proceeds step-by-step ensuring that everything is in place before major cards are played and they don't come any bigger than the 'Covid' hoax. The psychopaths can't handle events where the outcome isn't certain and as little as possible – preferably nothing – is left to chance. Politicians, government and medical officials who would follow direction were brought to illusory power in advance by the Cult web whether on the national stage or others like state governors and mayors of America. For decades the dynamic between officialdom, law enforcement and the public was changed from one of service to one of control and dictatorship. Behaviour manipulation networks established within government were waiting to impose the coming 'Covid' rules and regulations specifically designed to subdue and rewire the psyche of the people in the guise of protecting health. These included in the UK the Behavioural Insights Team part-owned by the British government Cabinet Office; the Scientific Pandemic Insights Group on Behaviours (SPI-B); and a whole web of intelligence and military groups seeking to direct the conversation on social media and control the narrative. Among them are the cyberwarfare (on the people) 77th Brigade of the British military which is also coordinated through the Cabinet Office as civilian and military leadership continues to combine in what they call the Fusion Doctrine. The 77th Brigade is a British equivalent of the infamous Israeli (Sabbatian) military cyberwarfare and Internet manipulation operation Unit 8200 which I expose at length in *The Trigger*. Also carefully in place were the medical and science advisers to government – many on the payroll past or present of Bill Gates – and a whole alternative structure of unelected government stood by to take control when elected parliaments were effectively closed down once the 'Covid' card was slammed on the table. The structure I have described here and so much more was installed in every major country through the Cult networks. The top-down control hierarchy looks like this: The Cult – Cult-owned Gates – the World Health Organization and Tedros – Gates-funded or controlled chief medical officers and science 'advisers' (dictators) in each country –

political 'leaders' – law enforcement – The People. Through this simple global communication and enforcement structure the policy of the Cult could be imposed on virtually the entire human population so long as they acquiesced to the fascism. With everything in place it was time for the button to be pressed in late 2019/early 2020.

These were the prime goals the Cult had to secure for its will to prevail:

1) Locking down economies, closing all but designated 'essential' businesses (Cult-owned corporations were 'essential'), and putting the population under house arrest was an imperative to destroy independent income and employment and ensure dependency on the Cult-controlled state in the Hunger Games Society. Lockdowns had to be established as the global blueprint from the start to respond to the 'virus' and followed by pretty much the entire world.

2) The global population had to be terrified into believing in a deadly 'virus' that didn't actually exist so they would unquestioningly obey authority in the belief that authority must know how best to protect them and their families. Software salesman Gates would suddenly morph into the world's health expert and be promoted as such by the Cult-owned media.

3) A method of testing that wasn't testing for the 'virus', but was only claimed to be, had to be in place to provide the illusion of 'cases' and subsequent 'deaths' that had a very different cause to the 'Covid-19' that would be scribbled on the death certificate.

4) Because there was no 'virus' and the great majority testing positive with a test not testing for the 'virus' would have no symptoms of anything the lie had to be sold that people without symptoms (without the 'virus') could still pass it on to others. This was crucial to justify for the first time quarantining – house arresting – healthy people. Without this the economy-destroying lockdown of *everybody* could not have been credibly sold.

5) The 'saviour' had to be seen as a vaccine which beyond evil drug companies were working like angels of mercy to develop as quickly as possible, with all corners cut, to save the day. The public must absolutely not know that the 'vaccine' had nothing to do with a 'virus' or that the contents were ready and waiting with a very different motive long before the 'Covid' card was even lifted from the pack.

I said in March, 2020, that the 'vaccine' would have been created way ahead of the 'Covid' hoax which justified its use and the following December an article in the New York *Intelligencer* magazine said the Moderna 'vaccine' had been 'designed' by

January, 2020. This was 'before China had even acknowledged that the disease could be transmitted from human to human, more than a week before the first confirmed coronavirus case in the United States'. The article said that by the time the first American death was announced a month later 'the vaccine had already been manufactured and shipped to the National Institutes of Health for the beginning of its Phase I clinical trial'. The 'vaccine' was actually 'designed' long before that although even with this timescale you would expect the article to ask how on earth it could have been done that quickly. Instead it asked why the 'vaccine' had not been rolled out then and not months later. Journalism in the mainstream is truly dead. I am going to detail in the next chapter why the 'virus' has never existed and how a hoax on that scale was possible, but first the foundation on which the Big Lie of 'Covid' was built.

### **The test that doesn't test**

Fraudulent 'testing' is the bottom line of the whole 'Covid' hoax and was the means by which a 'virus' that did not exist *appeared* to exist. They could only achieve this magic trick by using a test not testing for the 'virus'. To use a test that *was* testing for the 'virus' would mean that every test would come back negative given there was no 'virus'. They chose to exploit something called the RT-PCR test invented by American biochemist Kary Mullis in the 1980s who said publicly that his PCR test ... *cannot detect infectious disease*. Yes, the 'test' used worldwide to detect infectious 'Covid' to produce all the illusory 'cases' and 'deaths' compiled by Johns Hopkins and others *cannot detect infectious disease*. This fact came from the mouth of the man who invented PCR and was awarded the Nobel Prize in Chemistry in 1993 for doing so. Sadly, and incredibly conveniently for the Cult, Mullis died in August, 2019, at the age of 74 just before his test would be fraudulently used to unleash fascism on the world. He was said to have died from pneumonia which was an irony in itself. A few months later he would have had 'Covid-19' on his death certificate. I say the timing of his death was convenient because had he lived Mullis, a brilliant, honest and decent man, would have been

vociferously speaking out against the use of his test to detect 'Covid' when it was never designed, or able, to do that. I know that to be true given that Mullis made the same point when his test was used to 'detect' – not detect – HIV. He had been seriously critical of the Gallo/Montagnier claim to have isolated the HIV 'virus' and shown it to cause AIDS for which Mullis said there was no evidence. AIDS is actually not a disease but a series of diseases from which people die all the time. When they die from those *same diseases* after a positive 'test' for HIV then AIDS goes on their death certificate. I think I've heard that before somewhere. Countries instigated a policy with 'Covid' that anyone who tested positive with a test not testing for the 'virus' and died of any other cause within 28 days and even longer 'Covid-19' had to go on the death certificate. Cases have come from the test that can't test for infectious disease and the deaths are those who have died of *anything* after testing positive with a test not testing for the 'virus'. I'll have much more later about the death certificate scandal.

Mullis was deeply dismissive of the now US 'Covid' star Anthony Fauci who he said was a liar who didn't know anything about anything – 'and I would say that to his face – nothing.' He said of Fauci: 'The man thinks he can take a blood sample, put it in an electron microscope and if it's got a virus in there you'll know it – he doesn't understand electron microscopy and he doesn't understand medicine and shouldn't be in a position like he's in.' That position, terrifyingly, has made him the decider of 'Covid' fascism policy on behalf of the Cult in his role as director since 1984 of the National Institute of Allergy and Infectious Diseases (NIAID) while his record of being wrong is laughable; but being wrong, so long as it's the *right kind* of wrong, is why the Cult loves him. He'll say anything the Cult tells him to say. Fauci was made Chief Medical Adviser to the President immediately Biden took office. Biden was installed in the White House by Cult manipulation and one of his first decisions was to elevate Fauci to a position of even more control. This is a coincidence? Yes, and I identify as a flamenco dancer called Lola. How does such an incompetent criminal like Fauci remain in that

pivotal position in American health since *the 1980s*? When you serve the Cult it looks after you until you are surplus to requirements. Kary Mullis said prophetically of Fauci and his like: 'Those guys have an agenda and it's not an agenda we would like them to have ... they make their own rules, they change them when they want to, and Tony Fauci does not mind going on television in front of the people who pay his salary and lie directly into the camera.' Fauci has done that almost daily since the 'Covid' hoax began. Lying is in Fauci's DNA. To make the situation crystal clear about the PCR test this is a direct quote from its inventor Kary Mullis:

It [the PCR test] doesn't tell you that you're sick and doesn't tell you that the thing you ended up with was really going to hurt you ...'

Ask yourself why governments and medical systems the world over have been using this very test to decide who is 'infected' with the SARS-CoV-2 'virus' and the alleged disease it allegedly causes, 'Covid-19'. The answer to that question will tell you what has been going on. By the way, here's a little show-stopper – the 'new' SARS-CoV-2 'virus' was 'identified' as such right from the start using ... *the PCR test not testing for the 'virus'*. If you are new to this and find that shocking then stick around. I have hardly started yet. Even worse, other 'tests', like the 'Lateral Flow Device' (LFD), are considered so useless that they have to be *confirmed* by the PCR test! Leaked emails written by Ben Dyson, adviser to UK 'Health' Secretary Matt Hancock, said they were 'dangerously unreliable'. Dyson, executive director of strategy at the Department of Health, wrote: 'As of today, someone who gets a positive LFD result in (say) London has at best a 25 per cent chance of it being a true positive, but if it is a self-reported test potentially as low as 10 per cent (on an optimistic assumption about specificity) or as low as 2 per cent (on a more pessimistic assumption).' These are the 'tests' that schoolchildren and the public are being urged to have twice a week or more and have to isolate if they get a positive. Each fake positive goes in the statistics as a 'case' no matter how ludicrously inaccurate and the

'cases' drive lockdown, masks and the pressure to 'vaccinate'. The government said in response to the email leak that the 'tests' were accurate which confirmed yet again what shocking bloody liars they are. The real false positive rate is *100 percent* as we'll see. In another 'you couldn't make it up' the UK government agreed to pay £2.8 billion to California's Innova Medical Group to supply the irrelevant lateral flow tests. The company's primary test-making centre is in China. Innova Medical Group, established in March, 2020, is owned by Pasaca Capital Inc, chaired by Chinese-American millionaire Charles Huang who was born in Wuhan.

### **How it works – and how it doesn't**

The RT-PCR test, known by its full title of Polymerase chain reaction, is used across the world to make millions, even billions, of copies of a DNA/RNA genetic information sample. The process is called 'amplification' and means that a tiny sample of genetic material is amplified to bring out the detailed content. I stress that it is not testing for an infectious disease. It is simply amplifying a sample of genetic material. In the words of Kary Mullis: 'PCR is ... just a process that's used to make a whole lot of something out of something.' To emphasise the point companies that make the PCR tests circulated around the world to 'test' for 'Covid' warn on the box that it can't be used to detect 'Covid' or infectious disease and is for research purposes only. It's okay, rest for a minute and you'll be fine. This is the test that produces the 'cases' and 'deaths' that have been used to destroy human society. All those global and national medical and scientific 'experts' demanding this destruction to 'save us' *KNOW* that the test is not testing for the 'virus' and the cases and deaths they claim to be real are an almost unimaginable fraud. Every one of them and so many others including politicians and psychopaths like Gates and Tedros must be brought before Nuremburg-type trials and jailed for the rest of their lives. The more the genetic sample is amplified by PCR the more elements of that material become sensitive to the test and by that I don't mean sensitive for a 'virus' but for elements of the genetic material which

is *naturally* in the body or relates to remnants of old conditions of various kinds lying dormant and causing no disease. Once the amplification of the PCR reaches a certain level *everyone* will test positive. So much of the material has been made sensitive to the test that everyone will have some part of it in their body. Even lying criminals like Fauci have said that once PCR amplifications pass 35 cycles everything will be a false positive that cannot be trusted for the reasons I have described. I say, like many proper doctors and scientists, that 100 percent of the 'positives' are false, but let's just go with Fauci for a moment.

He says that any amplification over 35 cycles will produce false positives and yet the US Centers for Disease Control (CDC) and Food and Drug Administration (FDA) have recommended up to 40 *cycles* and the National Health Service (NHS) in Britain admitted in an internal document for staff that it was using 45 *cycles* of amplification. A long list of other countries has been doing the same and at least one 'testing' laboratory has been using 50 *cycles*. Have you ever heard a doctor, medical 'expert' or the media ask what level of amplification has been used to claim a 'positive'. The 'test' comes back 'positive' and so you have the 'virus', end of story. Now we can see how the government in Tanzania could send off samples from a goat and a pawpaw fruit under human names and both came back positive for 'Covid-19'. Tanzania president John Magufuli mocked the 'Covid' hysteria, the PCR test and masks and refused to import the DNA-manipulating 'vaccine'. The Cult hated him and an article sponsored by the Bill Gates Foundation appeared in the London *Guardian* in February, 2021, headed 'It's time for Africa to rein in Tanzania's anti-vaxxer president'. Well, 'reined in' he shortly was. Magufuli appeared in good health, but then, in March, 2021, he was dead at 61 from 'heart failure'. He was replaced by Samia Hassan Suhulu who is connected to Klaus Schwab's World Economic Forum and she immediately reversed Magufuli's 'Covid' policy. A sample of cola tested positive for 'Covid' with the PCR test in Germany while American actress and singer-songwriter Erykah Badu tested positive in one nostril and negative in the other. Footballer Ronaldo called



the PCR test 'bullshit' after testing positive three times and being forced to quarantine and miss matches when there was nothing wrong with him. The mantra from Tedros at the World Health Organization and national governments (same thing) has been test, test, test. They know that the more tests they can generate the more fake 'cases' they have which go on to become 'deaths' in ways I am coming to. The UK government has its Operation Moonshot planned to test multiple millions every day in workplaces and schools with free tests for everyone to use twice a week at home in line with the Cult plan from the start to make testing part of life. A government advertisement for an 'Interim Head of Asymptomatic Testing Communication' said the job included responsibility for delivering a 'communications strategy' (propaganda) 'to support the expansion of asymptomatic testing that *'normalises testing as part of everyday life'*'. More tests means more fake 'cases', 'deaths' and fascism. I have heard of, and from, many people who booked a test, couldn't turn up, and yet got a positive result through the post for a test they'd never even had. The whole thing is crazy, but for the Cult there's method in the madness. Controlling and manipulating the level of amplification of the test means the authorities can control whenever they want the number of apparent 'cases' and 'deaths'. If they want to justify more fascist lockdown and destruction of livelihoods they keep the amplification high. If they want to give the illusion that lockdowns and the 'vaccine' are working then they lower the amplification and 'cases' and 'deaths' will appear to fall. In January, 2021, the Cult-owned World Health Organization suddenly warned laboratories about over-amplification of the test and to lower the threshold. Suddenly headlines began appearing such as: 'Why ARE "Covid" cases plummeting?' This was just when the vaccine rollout was underway and I had predicted months before they would make cases appear to fall through amplification tampering when the 'vaccine' came. These people are so predictable.

## **Cow vaccines?**

The question must be asked of what is on the test swabs being poked far up the nose of the population to the base of the brain? A nasal swab punctured one woman's brain and caused it to leak fluid. Most of these procedures are being done by people with little training or medical knowledge. Dr Lorraine Day, former orthopaedic trauma surgeon and Chief of Orthopaedic Surgery at San Francisco General Hospital, says the tests are really a 'vaccine'. Cows have long been vaccinated this way. She points out that masks have to cover the nose and the mouth where it is claimed the 'virus' exists in saliva. Why then don't they take saliva from the mouth as they do with a DNA test instead of pushing a long swab up the nose towards the brain? The ethmoid bone separates the nasal cavity from the brain and within that bone is the cribriform plate. Dr Day says that when the swab is pushed up against this plate and twisted the procedure is 'depositing things back there'. She claims that among these 'things' are nanoparticles that can enter the brain. Researchers have noted that a team at the Gates-funded Johns Hopkins have designed tiny, star-shaped micro-devices that can latch onto intestinal mucosa and release drugs into the body. Mucosa is the thin skin that covers the inside surface of parts of the body such as *the nose* and mouth and produces mucus to protect them. The Johns Hopkins micro-devices are called 'theragrippers' and were 'inspired' by a parasitic worm that digs its sharp teeth into a host's intestines. Nasal swabs are also coated in the sterilisation agent ethylene oxide. The US National Cancer Institute posts this explanation on its website:

At room temperature, ethylene oxide is a flammable colorless gas with a sweet odor. It is used primarily to produce other chemicals, including antifreeze. In smaller amounts, ethylene oxide is used as a pesticide and a sterilizing agent. The ability of ethylene oxide to damage DNA makes it an effective sterilizing agent but also accounts for its cancer-causing activity.

The Institute mentions lymphoma and leukaemia as cancers most frequently reported to be associated with occupational exposure to ethylene oxide along with stomach and breast cancers. How does anyone think this is going to work out with the constant testing

regime being inflicted on adults and children at home and at school that will accumulate in the body anything that's on the swab?

## **Doctors know best**

It is vital for people to realise that 'hero' doctors 'know' only what the Big Pharma-dominated medical authorities tell them to 'know' and if they refuse to 'know' what they are told to 'know' they are out the door. They are mostly not physicians or healers, but repeaters of the official narrative – or else. I have seen alleged professional doctors on British television make shocking statements that we are supposed to take seriously. One called 'Dr' Amir Khan, who is actually telling patients how to respond to illness, said that men could take the birth pill to 'help slow down the effects of Covid-19'. In March, 2021, another ridiculous 'Covid study' by an American doctor proposed injecting men with the female sex hormone progesterone as a 'Covid' treatment. British doctor Nighat Arif told the BBC that face coverings were now going to be part of ongoing normal. Yes, the vaccine protects you, she said (evidence?) ... but the way to deal with viruses in the community was always going to come down to hand washing, face covering and keeping a physical distance. That's not what we were told before the 'vaccine' was circulating. Arif said she couldn't imagine ever again going on the underground or in a lift without a mask. I was just thanking my good luck that she was not my doctor when she said – in March, 2021 – that if 'we are *behaving* and we are doing all the right things' she thought we could 'have our nearest and dearest around us at home ... around *Christmas* and *New Year!* Her patronising delivery was the usual school teacher talking to six-year-olds as she repeated every government talking point and probably believed them all. If we have learned anything from the 'Covid' experience surely it must be that humanity's perception of doctors needs a fundamental rethink. NHS 'doctor' Sara Kayat told her television audience that the 'Covid vaccine' would '100 percent prevent hospitalisation and death'. Not even Big Pharma claimed that. We have to stop taking 'experts' at their word without question when so many of them are

clueless and only repeating the party line on which their careers depend. That is not to say there are not brilliant doctors – there are and I have spoken to many of them since all this began – but you won't see them in the mainstream media or quoted by the psychopaths and yes-people in government.

### **Remember the name – Christian Drosten**

German virologist Christian Drosten, Director of Charité Institute of Virology in Berlin, became a national star after the pandemic hoax began. He was feted on television and advised the German government on 'Covid' policy. Most importantly to the wider world Drosten led a group that produced the 'Covid' testing protocol for the PCR test. What a remarkable feat given the PCR cannot test for infectious disease and even more so when you think that Drosten said that his method of testing for SARS-CoV-2 was developed 'without having virus material available'. *He developed a test for a 'virus' that he didn't have and had never seen.* Let that sink in as you survey the global devastation that came from what he did. The whole catastrophe of Drosten's 'test' was based on the alleged genetic sequence published by Chinese scientists on the Internet. We will see in the next chapter that this alleged 'genetic sequence' has never been produced by China or anyone and cannot be when there *is no* SARS-CoV-2. Drosten, however, doesn't seem to let little details like that get in the way. He was the lead author with Victor Corman from the same Charité Hospital of the paper 'Detection of 2019 novel coronavirus (2019-nCoV) by real-time PCR' published in a magazine called *Eurosurveillance*. This became known as the Corman-Drosten paper. In November, 2020, with human society devastated by the effects of the Corman-Drosten test baloney, the protocol was publicly challenged by 22 international scientists and independent researchers from Europe, the United States, and Japan. Among them were senior molecular geneticists, biochemists, immunologists, and microbiologists. They produced a document headed 'External peer review of the RTPCR test to detect SARS-Cov-2 Reveals 10 Major Flaws At The Molecular and Methodological Level: Consequences

For False-Positive Results'. The flaws in the Corman-Drosten test included the following:

- The test is non-specific because of erroneous design
- Results are enormously variable
- The test is unable to discriminate between the whole 'virus' and viral fragments
- It doesn't have positive or negative controls
- The test lacks a standard operating procedure
- It is unsupported by proper peer view

The scientists said the PCR 'Covid' testing protocol was not founded on science and they demanded the Corman-Drosten paper be retracted by *Eurosurveillance*. They said all present and previous Covid deaths, cases, and 'infection rates' should be subject to a massive retroactive inquiry. Lockdowns and travel restrictions should be reviewed and relaxed and those diagnosed through PCR to have 'Covid-19' should not be forced to isolate. Dr Kevin Corbett, a health researcher and nurse educator with a long academic career producing a stream of peer-reviewed publications at many UK universities, made the same point about the PCR test debacle. He said of the scientists' conclusions: 'Every scientific rationale for the development of that test has been totally destroyed by this paper. It's like Hiroshima/Nagasaki to the Covid test.' He said that China hadn't given them an isolated 'virus' when Drosten developed the test. Instead they had developed the test from *a sequence in a gene bank*.' Put another way ... *they made it up!* The scientists were supported in this contention by a Portuguese appeals court which ruled in November, 2020, that PCR tests are unreliable and it is unlawful to quarantine people based solely on a PCR test. The point about China not providing an isolated virus must be true when the 'virus' has never been isolated to this day and the consequences of that will become clear. Drosten and company produced this useless 'protocol' right on cue in January, 2020, just as the 'virus' was said to

be moving westward and it somehow managed to successfully pass a peer-review in 24 hours. In other words there was no peer-review for a test that would be used to decide who had 'Covid' and who didn't across the world. The Cult-created, Gates-controlled World Health Organization immediately recommended all its nearly 200 member countries to use the Drosten PCR protocol to detect 'cases' and 'deaths'. The sting was underway and it continues to this day.

So who is this Christian Drosten that produced the means through which death, destruction and economic catastrophe would be justified? His education background, including his doctoral thesis, would appear to be somewhat shrouded in mystery and his track record is dire as with another essential player in the 'Covid' hoax, the Gates-funded Professor Neil Ferguson at the Gates-funded Imperial College in London of whom more shortly. Drosten predicted in 2003 that the alleged original SARS 'virus' (SARS-1) was an epidemic that could have serious effects on economies and an effective vaccine would take at least two years to produce. Drosten's answer to every alleged 'outbreak' is a vaccine which you won't be shocked to know. What followed were just 774 official deaths worldwide and none in Germany where there were only nine cases. That is even if you believe there ever was a SARS 'virus' when the evidence is zilch and I will expand on this in the next chapter. Drosten claims to be co-discoverer of 'SARS-1' and developed a test for it in 2003. He was screaming warnings about 'swine flu' in 2009 and how it was a widespread infection far more severe than any dangers from a vaccine could be and people should get vaccinated. It would be helpful for Drosten's vocal chords if he simply recorded the words 'the virus is deadly and you need to get vaccinated' and copies could be handed out whenever the latest made-up threat comes along. Drosten's swine flu epidemic never happened, but Big Pharma didn't mind with governments spending hundreds of millions on vaccines that hardly anyone bothered to use and many who did wished they hadn't. A study in 2010 revealed that the risk of dying from swine flu, or H1N1, was no higher than that of the annual seasonal flu which is what at least most of 'it' really was as in

the case of 'Covid-19'. A media investigation into Drosten asked how with such a record of inaccuracy he could be *the* government adviser on these issues. The answer to that question is the same with Drosten, Ferguson and Fauci – they keep on giving the authorities the 'conclusions' and 'advice' they want to hear. Drosten certainly produced the goods for them in January, 2020, with his PCR protocol garbage and provided the foundation of what German internal medicine specialist Dr Claus Köhnlein, co-author of *Virus Mania*, called the 'test pandemic'. The 22 scientists in the *Eurosurveillance* challenge called out conflicts of interest within the Drosten 'protocol' group and with good reason. Olfert Landt, a regular co-author of Drosten 'studies', owns the biotech company TIB Molbiol Syntheselabor GmbH in Berlin which manufactures and sells the tests that Drosten and his mates come up with. They have done this with SARS, Enterotoxigenic E. coli (ETEC), MERS, Zika 'virus', yellow fever, and now 'Covid'. Landt told the *Berliner Zeitung* newspaper:

The testing, design and development came from the Charité [Drosten and Corman]. We simply implemented it immediately in the form of a kit. And if we don't have the virus, which originally only existed in Wuhan, we can make a synthetic gene to simulate the genome of the virus. That's what we did very quickly.

This is more confirmation that the Drosten test was designed without access to the 'virus' and only a synthetic simulation which is what SARS-CoV-2 really is – a computer-generated synthetic fiction. It's quite an enterprise they have going here. A Drosten team decides what the test for something should be and Landt's biotech company flogs it to governments and medical systems across the world. His company must have made an absolute fortune since the 'Covid' hoax began. Dr Reiner Fuellmich, a prominent German consumer protection trial lawyer in Germany and California, is on Drosten's case and that of Tedros at the World Health Organization for crimes against humanity with a class-action lawsuit being prepared in the United States and other legal action in Germany.

## Why China?

Scamming the world with a 'virus' that doesn't exist would seem impossible on the face of it, but not if you have control of the relatively few people that make policy decisions and the great majority of the global media. Remember it's not about changing 'real' reality it's about controlling *perception* of reality. You don't have to make something happen you only have to make people *believe* that it's happening. Renegade Minds understand this and are therefore much harder to swindle. 'Covid-19' is not a 'real' 'virus'. It's a mind virus, like a computer virus, which has infected the minds, not the bodies, of billions. It all started, publically at least, in China and that alone is of central significance. The Cult was behind the revolution led by its asset Mao Zedong, or Chairman Mao, which established the People's Republic of China on October 1st, 1949. It should have been called The Cult's Republic of China, but the name had to reflect the recurring illusion that vicious dictatorships are run by and for the people (see all the 'Democratic Republics' controlled by tyrants). In the same way we have the 'Biden' Democratic Republic of America officially ruled by a puppet tyrant (at least temporarily) on behalf of Cult tyrants. The creation of Mao's merciless communist/fascist dictatorship was part of a frenzy of activity by the Cult at the conclusion of World War Two which, like the First World War, it had instigated through its assets in Germany, Britain, France, the United States and elsewhere. Israel was formed in 1948; the Soviet Union expanded its 'Iron Curtain' control, influence and military power with the Warsaw Pact communist alliance in 1955; the United Nations was formed in 1945 as a Cult precursor to world government; and a long list of world bodies would be established including the World Health Organization (1948), World Trade Organization (1948 under another name until 1995), International Monetary Fund (1945) and World Bank (1944). Human society was redrawn and hugely centralised in the global Problem-Reaction-Solution that was World War Two. All these changes were significant. Israel would become the headquarters of the Sabbatians



and the revolution in China would prepare the ground and control system for the events of 2019/2020.

Renegade Minds know there are no borders except for public consumption. The Cult is a seamless, borderless global entity and to understand the game we need to put aside labels like borders, nations, countries, communism, fascism and democracy. These delude the population into believing that countries are ruled within their borders by a government of whatever shade when these are mere agencies of a global power. America's illusion of democracy and China's communism/fascism are subsidiaries – vehicles – for the same agenda. We may hear about conflict and competition between America and China and on the lower levels that will be true; but at the Cult level they are branches of the same company in the way of the McDonald's example I gave earlier. I have tracked in the books over the years support by US governments of both parties for Chinese Communist Party infiltration of American society through allowing the sale of land, even military facilities, and the acquisition of American business and university influence. All this is underpinned by the infamous stealing of intellectual property and technological know-how. Cult-owned Silicon Valley corporations waive their fraudulent 'morality' to do business with human-rights-free China; Cult-controlled Disney has become China's PR department; and China in effect owns 'American' sports such as basketball which depends for much of its income on Chinese audiences. As a result any sports player, coach or official speaking out against China's horrific human rights record is immediately condemned or fired by the China-worshipping National Basketball Association. One of the first acts of China-controlled Biden was to issue an executive order telling federal agencies to stop making references to the 'virus' by the 'geographic location of its origin'. Long-time Congressman Jerry Nadler warned that criticising China, America's biggest rival, leads to hate crimes against Asian people in the United States. So shut up you bigot. China is fast closing in on Israel as a country that must not be criticised which is apt, really, given that Sabbatians control them both. The two countries have

developed close economic, military, technological and strategic ties which include involvement in China's 'Silk Road' transport and economic initiative to connect China with Europe. Israel was the first country in the Middle East to recognise the establishment of Mao's tyranny in 1950 months after it was established.

### **Project Wuhan – the 'Covid' Psyop**

I emphasise again that the Cult plays the long game and what is happening to the world today is the result of centuries of calculated manipulation following a script to take control step-by-step of every aspect of human society. I will discuss later the common force behind all this that has spanned those centuries and thousands of years if the truth be told. Instigating the Mao revolution in China in 1949 with a 2020 'pandemic' in mind is not only how they work – the 71 years between them is really quite short by the Cult's standards of manipulation preparation. The reason for the Cult's Chinese revolution was to create a fiercely-controlled environment within which an extreme structure for human control could be incubated to eventually be unleashed across the world. We have seen this happen since the 'pandemic' emerged from China with the Chinese control-structure founded on AI technology and tyrannical enforcement sweep across the West. Until the moment when the Cult went for broke in the West and put its fascism on public display Western governments had to pay some lip-service to freedom and democracy to not alert too many people to the tyranny-in-the-making. Freedoms were more subtly eroded and power centralised with covert government structures put in place waiting for the arrival of 2020 when that smokescreen of 'freedom' could be dispensed with. The West was not able to move towards tyranny before 2020 anything like as fast as China which was created as a tyranny and had no limits on how fast it could construct the Cult's blueprint for global control. When the time came to impose that structure on the world it was the same Cult-owned Chinese communist/fascist government that provided the excuse – the 'Covid pandemic'. It was absolutely crucial to the Cult plan for the Chinese response to the 'pandemic' –

draconian lockdowns of the entire population – to become the blueprint that Western countries would follow to destroy the livelihoods and freedom of their people. This is why the Cult-owned, Gates-owned, WHO Director-General Tedros said early on:

The Chinese government is to be congratulated for the extraordinary measures it has taken to contain the outbreak. China is actually setting a new standard for outbreak response and it is not an exaggeration.

*Forbes* magazine said of China: ‘... those measures protected untold millions from getting the disease’. The Rockefeller Foundation ‘epidemic scenario’ document in 2010 said ‘prophetically’:

However, a few countries did fare better – China in particular. The Chinese government’s quick imposition and enforcement of mandatory quarantine for all citizens, as well as its instant and near-hermetic sealing off of all borders, saved millions of lives, stopping the spread of the virus far earlier than in other countries and enabling a swifter post-pandemic recovery.

Once again – *spooky*.

The first official story was the ‘bat theory’ or rather the bat diversion. The source of the ‘virus outbreak’ we were told was a ‘wet market’ in Wuhan where bats and other animals are bought and eaten in horrifically unhygienic conditions. Then another story emerged through the alternative media that the ‘virus’ had been released on purpose or by accident from a BSL-4 (biosafety level 4) laboratory in Wuhan not far from the wet market. The lab was reported to create and work with lethal concoctions and bioweapons. Biosafety level 4 is the highest in the World Health Organization system of safety and containment. Renegade Minds are aware of what I call designer manipulation. The ideal for the Cult is for people to buy its prime narrative which in the opening salvos of the ‘pandemic’ was the wet market story. It knows, however, that there is now a considerable worldwide alternative media of researchers sceptical of anything governments say and they are often given a version of events in a form they can perceive as credible while misdirecting them from the real truth. In this case let them

think that the conspiracy involved is a 'bioweapon virus' released from the Wuhan lab to keep them from the real conspiracy – *there is no 'virus'*. The WHO's current position on the source of the outbreak at the time of writing appears to be: 'We haven't got a clue, mate.' This is a good position to maintain mystery and bewilderment. The inner circle will know where the 'virus' came from – *nowhere*. The bottom line was to ensure the public believed there *was* a 'virus' and it didn't much matter if they thought it was natural or had been released from a lab. The belief that there was a 'deadly virus' was all that was needed to trigger global panic and fear. The population was terrified into handing their power to authority and doing what they were told. They had to or they were 'all gonna die'.

In March, 2020, information began to come my way from real doctors and scientists and my own additional research which had my intuition screaming: 'Yes, that's it! *There is no virus.*' The 'bioweapon' was not the 'virus'; it was the '*vaccine*' already being talked about that would be the bioweapon. My conclusion was further enhanced by happenings in Wuhan. The 'virus' was said to be sweeping the city and news footage circulated of people collapsing in the street (which they've never done in the West with the same 'virus'). The Chinese government was building 'new hospitals' in a matter of ten days to 'cope with demand' such was the virulent nature of the 'virus'. Yet in what seemed like no time the 'new hospitals' closed – even if they even opened – and China declared itself 'virus-free'. It was back to business as usual. This was more propaganda to promote the Chinese draconian lockdowns in the West as the way to 'beat the virus'. Trouble was that we subsequently had lockdown after lockdown, but never business as usual. As the people of the West and most of the rest of the world were caught in an ever-worsening spiral of lockdown, social distancing, masks, isolated old people, families forced apart, and livelihood destruction, it was party-time in Wuhan. Pictures emerged of thousands of people enjoying pool parties and concerts. It made no sense until you realised there never was a 'virus' and the

whole thing was a Cult set-up to transform human society out of one of its major global strongholds – China.

How is it possible to deceive virtually the entire world population into believing there is a deadly virus when there is not even a 'virus' let alone a deadly one? It's nothing like as difficult as you would think and that's clearly true because it happened.

**Postscript:** See end of book Postscript for more on the 'Wuhan lab virus release' story which the authorities and media were pushing heavily in the summer of 2021 to divert attention from the truth that the 'Covid virus' is pure invention.

## CHAPTER FIVE

### ***There is no 'virus'***

*You can fool some of the people all of the time, and all of the people some of the time, but you cannot fool all of the people all of the time*

Abraham Lincoln

The greatest form of mind control is repetition. The more you repeat the same mantra of alleged 'facts' the more will accept them to be true. It becomes an 'everyone knows that, mate'. If you can also censor any other version or alternative to your alleged 'facts' you are pretty much home and cooking.

By the start of 2020 the Cult owned the global mainstream media almost in its entirety to spew out its 'Covid' propaganda and ignore or discredit any other information and view. Cult-owned social media platforms in Cult-owned Silicon Valley were poised and ready to unleash a campaign of ferocious censorship to obliterate all but the official narrative. To complete the circle many demands for censorship by Silicon Valley were led by the mainstream media as 'journalists' became full-out enforcers for the Cult both as propagandists and censors. Part of this has been the influx of young people straight out of university who have become 'journalists' in significant positions. They have no experience and a headful of programmed perceptions from their years at school and university at a time when today's young are the most perceptually-targeted generations in known human history given the insidious impact of technology. They enter the media perceptually prepared and ready to repeat the narratives of the system that programmed them to

repeat its narratives. The BBC has a truly pathetic 'specialist disinformation reporter' called Marianna Spring who fits this bill perfectly. She is clueless about the world, how it works and what is really going on. Her role is to discredit anyone doing the job that a proper journalist would do and system-serving hacks like Spring wouldn't dare to do or even see the need to do. They are too busy licking the arse of authority which can never be wrong and, in the case of the BBC propaganda programme, *Panorama*, contacting payments systems such as PayPal to have a donations page taken down for a film company making documentaries questioning vaccines. Even the BBC soap opera *EastEnders* included a disgracefully biased scene in which an inarticulate white working class woman was made to look foolish for questioning the 'vaccine' while a well-spoken black man and Asian woman promoted the government narrative. It ticked every BBC box and the fact that the black and minority community was resisting the 'vaccine' had nothing to do with the way the scene was written. The BBC has become a disgusting tyrannical propaganda and censorship operation that should be defunded and disbanded and a free media take its place with a brief to stop censorship instead of demanding it. A BBC 'interview' with Gates goes something like: 'Mr Gates, sir, if I can call you sir, would you like to tell our audience why you are such a great man, a wonderful humanitarian philanthropist, and why you should absolutely be allowed as a software salesman to decide health policy for approaching eight billion people? Thank you, sir, please sir.' Propaganda programming has been incessant and merciless and when all you hear is the same story from the media, repeated by those around you who have only heard the same story, is it any wonder that people on a grand scale believe absolute mendacious garbage to be true? You are about to see, too, why this level of information control is necessary when the official 'Covid' narrative is so nonsensical and unsupportable by the evidence.

## **Structure of Deceit**

The pyramid structure through which the 'Covid' hoax has been manifested is very simple and has to be to work. As few people as possible have to be involved with full knowledge of what they are doing – and why – or the real story would get out. At the top of the pyramid are the inner core of the Cult which controls Bill Gates who, in turn, controls the World Health Organization through his pivotal funding and his puppet Director-General mouthpiece, Tedros. Before he was appointed Tedros was chair of the Gates-founded Global Fund to 'fight against AIDS, tuberculosis and malaria', a board member of the Gates-funded 'vaccine alliance' GAVI, and on the board of another Gates-funded organisation. Gates owns him and picked him for a specific reason – Tedros is a crook and worse. 'Dr' Tedros (he's not a medical doctor, the first WHO chief not to be) was a member of the tyrannical Marxist government of Ethiopia for decades with all its human rights abuses. He has faced allegations of corruption and misappropriation of funds and was exposed three times for covering up cholera epidemics while Ethiopia's health minister. Tedros appointed the mass-murdering genocidal Zimbabwe dictator Robert Mugabe as a WHO goodwill ambassador for public health which, as with Tedros, is like appointing a psychopath to run a peace and love campaign. The move was so ridiculous that he had to drop Mugabe in the face of widespread condemnation. American economist David Steinman, a Nobel peace prize nominee, lodged a complaint with the International Criminal Court in The Hague over alleged genocide by Tedros when he was Ethiopia's foreign minister. Steinman says Tedros was a 'crucial decision maker' who directed the actions of Ethiopia's security forces from 2013 to 2015 and one of three officials in charge when those security services embarked on the 'killing' and 'torturing' of Ethiopians. You can see where Tedros is coming from and it's sobering to think that he has been the vehicle for Gates and the Cult to direct the global response to 'Covid'. Think about that. A psychopathic Cult dictates to psychopath Gates who dictates to psychopath Tedros who dictates how countries of the world must respond to a 'Covid virus' never scientifically shown to exist. At the same time psychopathic Cult-owned Silicon Valley information



giants like Google, YouTube, Facebook and Twitter announced very early on that they would give the Cult/Gates/Tedros/WHO version of the narrative free advertising and censor those who challenged their intelligence-insulting, mendacious story.

The next layer in the global 'medical' structure below the Cult, Gates and Tedros are the chief medical officers and science 'advisers' in each of the WHO member countries which means virtually all of them. Medical officers and arbiters of science (they're not) then take the WHO policy and recommended responses and impose them on their country's population while the political 'leaders' say they are deciding policy (they're clearly not) by 'following the science' on the advice of the 'experts' – the same medical officers and science 'advisers' (dictators). In this way with the rarest of exceptions the entire world followed the same policy of lockdown, people distancing, masks and 'vaccines' dictated by the psychopathic Cult, psychopathic Gates and psychopathic Tedros who we are supposed to believe give a damn about the health of the world population they are seeking to enslave. That, amazingly, is all there is to it in terms of crucial decision-making. Medical staff in each country then follow like sheep the dictates of the shepherds at the top of the national medical hierarchies – chief medical officers and science 'advisers' who themselves follow like sheep the shepherds of the World Health Organization and the Cult. Shepherds at the national level often have major funding and other connections to Gates and his Bill and Melinda Gates Foundation which carefully hands out money like confetti at a wedding to control the entire global medical system from the WHO down.

### **Follow the money**

Christopher Whitty, Chief Medical Adviser to the UK Government at the centre of 'virus' policy, a senior adviser to the government's Scientific Advisory Group for Emergencies (SAGE), and Executive Board member of the World Health Organization, was gifted a grant of \$40 million by the Bill and Melinda Gates Foundation for malaria research in Africa. The BBC described the unelected Whitty as 'the

official who will probably have the greatest impact on our everyday lives of any individual policymaker in modern times' and so it turned out. What Gates and Tedros have said Whitty has done like his equivalents around the world. Patrick Vallance, co-chair of SAGE and the government's Chief Scientific Adviser, is a former executive of Big Pharma giant GlaxoSmithKline with its fundamental financial and business connections to Bill Gates. In September, 2020, it was revealed that Vallance owned a deferred bonus of shares in GlaxoSmithKline worth £600,000 while the company was 'developing' a 'Covid vaccine'. Move along now – nothing to see here – what could possibly be wrong with that? Imperial College in London, a major player in 'Covid' policy in Britain and elsewhere with its 'Covid-19' Response Team, is funded by Gates and has big connections to China while the now infamous Professor Neil Ferguson, the useless 'computer modeller' at Imperial College is also funded by Gates. Ferguson delivered the dramatically inaccurate excuse for the first lockdowns (much more in the next chapter). The Institute for Health Metrics and Evaluation (IHME) in the United States, another source of outrageously false 'Covid' computer models to justify lockdowns, is bankrolled by Gates who is a vehement promotor of lockdowns. America's version of Whitty and Vallance, the again now infamous Anthony Fauci, has connections to 'Covid vaccine' maker Moderna as does Bill Gates through funding from the Bill and Melinda Gates Foundation. Fauci is director of the National Institute of Allergy and Infectious Diseases (NIAID), a major recipient of Gates money, and they are very close. Deborah Birx who was appointed White House Coronavirus Response Coordinator in February, 2020, is yet another with ties to Gates. Everywhere you look at the different elements around the world behind the coordination and decision making of the 'Covid' hoax there is Bill Gates and his money. They include the World Health Organization; Centers for Disease Control (CDC) in the United States; National Institutes of Health (NIH) of Anthony Fauci; Imperial College and Neil Ferguson; the London School of Hygiene where Chris Whitty worked; Regulatory agencies like the UK Medicines & Healthcare products Regulatory Agency (MHRA)

which gave emergency approval for 'Covid vaccines'; Wellcome Trust; GAVI, the Vaccine Alliance; the Coalition for Epidemic Preparedness Innovations (CEPI); Johns Hopkins University which has compiled the false 'Covid' figures; and the World Economic Forum. A [Nationalfile.com](http://Nationalfile.com) article said:

Gates has a lot of pull in the medical world, he has a multi-million dollar relationship with Dr. Fauci, and Fauci originally took the Gates line supporting vaccines and casting doubt on [the drug hydroxychloroquine]. Coronavirus response team member Dr. Deborah Birx, appointed by former president Obama to serve as United States Global AIDS Coordinator, also sits on the board of a group that has received billions from Gates' foundation, and Birx reportedly used a disputed Bill Gates-funded model for the White House's Coronavirus effort. Gates is a big proponent for a population lockdown scenario for the Coronavirus outbreak.

Another funder of Moderna is the Defense Advanced Research Projects Agency (DARPA), the technology-development arm of the Pentagon and one of the most sinister organisations on earth. DARPA had a major role with the CIA covert technology-funding operation In-Q-Tel in the development of Google and social media which is now at the centre of global censorship. Fauci and Gates are extremely close and openly admit to talking regularly about 'Covid' policy, but then why wouldn't Gates have a seat at every national 'Covid' table after his Foundation committed \$1.75 billion to the 'fight against Covid-19'. When passed through our Orwellian Translation Unit this means that he has bought and paid for the Cult-driven 'Covid' response worldwide. Research the major 'Covid' response personnel in your own country and you will find the same Gates funding and other connections again and again. Medical and science chiefs following World Health Organization 'policy' sit atop a medical hierarchy in their country of administrators, doctors and nursing staff. These 'subordinates' are told they must work and behave in accordance with the policy delivered from the 'top' of the national 'health' pyramid which is largely the policy delivered by the WHO which is the policy delivered by Gates and the Cult. The whole 'Covid' narrative has been imposed on medical staff by a climate of fear although great numbers don't even need that to comply. They do so through breathtaking levels of ignorance and

include doctors who go through life simply repeating what Big Pharma and their hierarchical masters tell them to say and believe. No wonder Big Pharma 'medicine' is one of the biggest killers on Planet Earth.

The same top-down system of intimidation operates with regard to the Cult Big Pharma cartel which also dictates policy through national and global medical systems in this way. The Cult and Big Pharma agendas are the same because the former controls and owns the latter. 'Health' administrators, doctors, and nursing staff are told to support and parrot the dictated policy or they will face consequences which can include being fired. How sad it's been to see medical staff meekly repeating and imposing Cult policy without question and most of those who can see through the deceit are only willing to speak anonymously off the record. They know what will happen if their identity is known. This has left the courageous few to expose the lies about the 'virus', face masks, overwhelmed hospitals that aren't, and the dangers of the 'vaccine' that isn't a vaccine. When these medical professionals and scientists, some renowned in their field, have taken to the Internet to expose the truth their articles, comments and videos have been deleted by Cult-owned Facebook, Twitter and YouTube. What a real head-shaker to see YouTube videos with leading world scientists and highly qualified medical specialists with an added link underneath to the notorious Cult propaganda website *Wikipedia* to find the 'facts' about the same subject.

### **HIV – the 'Covid' trial-run**

I'll give you an example of the consequences for health and truth that come from censorship and unquestioning belief in official narratives. The story was told by PCR inventor Kary Mullis in his book *Dancing Naked in the Mind Field*. He said that in 1984 he accepted as just another scientific fact that Luc Montagnier of France's Pasteur Institute and Robert Gallo of America's National Institutes of Health had independently discovered that a 'retrovirus' dubbed HIV (human immunodeficiency virus) caused AIDS. They

were, after all, Mullis writes, specialists in retroviruses. This is how the medical and science pyramids work. Something is announced or *assumed* and then becomes an everybody-knows-that purely through repetition of the assumption as if it is fact. Complete crap becomes accepted truth with no supporting evidence and only repetition of the crap. This is how a 'virus' that doesn't exist became the 'virus' that changed the world. The HIV-AIDS fairy story became a multi-billion pound industry and the media poured out propaganda terrifying the world about the deadly HIV 'virus' that caused the lethal AIDS. By then Mullis was working at a lab in Santa Monica, California, to detect retroviruses with his PCR test in blood donations received by the Red Cross. In doing so he asked a virologist where he could find a reference for HIV being the cause of AIDS. 'You don't need a reference,' the virologist said ... '*Everybody knows it.*' Mullis said he wanted to quote a reference in the report he was doing and he said he felt a little funny about not knowing the source of such an important discovery when everyone else seemed to. The virologist suggested he cite a report by the Centers for Disease Control and Prevention (CDC) on morbidity and mortality. Mullis read the report, but it only said that an organism had been identified and did not say how. The report did not identify the original scientific work. Physicians, however, *assumed* (key recurring theme) that if the CDC was convinced that HIV caused AIDS then proof must exist. Mullis continues:

I did computer searches. Neither Montagnier, Gallo, nor anyone else had published papers describing experiments which led to the conclusion that HIV probably caused AIDS. I read the papers in *Science* for which they had become well known as AIDS doctors, but all they had said there was that they had found evidence of a past infection by something which was probably HIV in some AIDS patients.

They found antibodies. Antibodies to viruses had always been considered evidence of past disease, not present disease. Antibodies signaled that the virus had been defeated. The patient had saved himself. There was no indication in these papers that this virus caused a disease. They didn't show that everybody with the antibodies had the disease. In fact they found some healthy people with antibodies.

Mullis asked why their work had been published if Montagnier and Gallo hadn't really found this evidence, and why had they been fighting so hard to get credit for the discovery? He says he was hesitant to write 'HIV is the probable cause of AIDS' until he found published evidence to support that. 'Tens of thousands of scientists and researchers were spending billions of dollars a year doing research based on this idea,' Mullis writes. 'The reason had to be there somewhere; otherwise these people would not have allowed their research to settle into one narrow channel of investigation.' He said he lectured about PCR at numerous meetings where people were always talking about HIV and he asked them how they knew that HIV was the cause of AIDS:

Everyone said something. Everyone had the answer at home, in the office, in some drawer. They all knew, and they would send me the papers as soon as they got back. But I never got any papers. Nobody ever sent me the news about how AIDS was caused by HIV.

Eventually Mullis was able to ask Montagnier himself about the reference proof when he lectured in San Diego at the grand opening of the University of California AIDS Research Center. Mullis says this was the last time he would ask his question without showing anger. Montagnier said he should reference the CDC report. 'I read it', Mullis said, and it didn't answer the question. 'If Montagnier didn't know the answer who the hell did?' Then one night Mullis was driving when an interview came on National Public Radio with Peter Duesberg, a prominent virologist at Berkeley and a California Scientist of the Year. Mullis says he finally understood why he could not find references that connected HIV to AIDS – *there weren't any!* No one had ever proved that HIV causes AIDS even though it had spawned a multi-billion pound global industry and the media was repeating this as fact every day in their articles and broadcasts terrifying the shit out of people about AIDS and giving the impression that a positive test for HIV (see 'Covid') was a death sentence. Duesberg was a threat to the AIDS gravy train and the agenda that underpinned it. He was therefore abused and castigated after he told the Proceedings of the National Academy of Sciences

there was no good evidence implicating the new 'virus'. Editors rejected his manuscripts and his research funds were deleted. Mullis points out that the CDC has defined AIDS as one of more than 30 diseases *if accompanied* by a positive result on a test that detects antibodies to HIV; but those same diseases are not defined as AIDS cases when antibodies are not detected:

If an HIV-positive woman develops uterine cancer, for example, she is considered to have AIDS. If she is not HIV positive, she simply has uterine cancer. An HIV-positive man with tuberculosis has AIDS; if he tests negative he simply has tuberculosis. If he lives in Kenya or Colombia, where the test for HIV antibodies is too expensive, he is simply presumed to have the antibodies and therefore AIDS, and therefore he can be treated in the World Health Organization's clinic. It's the only medical help available in some places. And it's free, because the countries that support WHO are worried about AIDS.

Mullis accuses the CDC of continually adding new diseases (see ever more 'Covid symptoms') to the grand AIDS definition and of virtually doctoring the books to make it appear as if the disease continued to spread. He cites how in 1993 the CDC enormously broadened its AIDS definition and county health authorities were delighted because they received \$2,500 per year from the Federal government for every reported AIDS case. Ladies and gentlemen, I have just described, via Kary Mullis, the 'Covid pandemic' of 2020 and beyond. Every element is the same and it's been pulled off in the same way by the same networks.

### **The 'Covid virus' exists? Okay – prove it. Er ... still waiting**

What Kary Mullis described with regard to 'HIV' has been repeated with 'Covid'. A claim is made that a new, or 'novel', infection has been found and the entire medical system of the world repeats that as fact exactly as they did with HIV and AIDS. No one in the mainstream asks rather relevant questions such as 'How do you know?' and 'Where is your proof?' The SARS-Cov-2 'virus' and the 'Covid-19 disease' became an overnight 'everybody-knows-that'. The origin could be debated and mulled over, but what you could not suggest was that 'SARS-Cov-2' didn't exist. That would be

ridiculous. 'Everybody knows' the 'virus' exists. Well, I didn't for one along with American proper doctors like Andrew Kaufman and Tom Cowan and long-time American proper journalist Jon Rappaport. We dared to pursue the obvious and simple question: 'Where's the evidence?' The overwhelming majority in medicine, journalism and the general public did not think to ask that. After all, *everyone knew* there was a new 'virus'. Everyone was saying so and I heard it on the BBC. Some would eventually argue that the 'deadly virus' was nothing like as deadly as claimed, but few would venture into the realms of its very existence. Had they done so they would have found that the evidence for that claim had gone AWOL as with HIV causes AIDS. In fact, not even that. For something to go AWOL it has to exist in the first place and scientific proof for a 'SARS-Cov-2' can be filed under nothing, nowhere and zilch.

Dr Andrew Kaufman is a board-certified forensic psychiatrist in New York State, a Doctor of Medicine and former Assistant Professor and Medical Director of Psychiatry at SUNY Upstate Medical University, and Medical Instructor of Hematology and Oncology at the Medical School of South Carolina. He also studied biology at the Massachusetts Institute of Technology (MIT) and trained in Psychiatry at Duke University. Kaufman is retired from allopathic medicine, but remains a consultant and educator on natural healing, I saw a video of his very early on in the 'Covid' hoax in which he questioned claims about the 'virus' in the absence of any supporting evidence and with plenty pointing the other way. I did everything I could to circulate his work which I felt was asking the pivotal questions that needed an answer. I can recommend an excellent pull-together interview he did with the website The Last Vagabond entitled *Dr Andrew Kaufman: Virus Isolation, Terrain Theory and Covid-19* and his website is [andrewkaufmanmd.com](http://andrewkaufmanmd.com). Kaufman is not only a forensic psychiatrist; he is forensic in all that he does. He always reads original scientific papers, experiments and studies instead of second-third-fourth-hand reports about the 'virus' in the media which are repeating the repeated repetition of the narrative. When he did so with the original Chinese 'virus' papers Kaufman



realised that there was no evidence of a 'SARS-Cov-2'. They had never – from the start – shown it to exist and every repeat of this claim worldwide was based on the accepted existence of proof that was nowhere to be found – see Kary Mullis and HIV. Here we go again.

## **Let's postulate**

Kaufman discovered that the Chinese authorities immediately concluded that the cause of an illness that broke out among about 200 initial patients in Wuhan was a 'new virus' when there were no grounds to make that conclusion. The alleged 'virus' was not isolated from other genetic material in their samples and then shown through a system known as Koch's postulates to be the causative agent of the illness. The world was told that the SARS-Cov-2 'virus' caused a disease they called 'Covid-19' which had 'flu-like' symptoms and could lead to respiratory problems and pneumonia. If it wasn't so tragic it would almost be funny. *'Flu-like' symptoms? Pneumonia? Respiratory disease?* What in CHINA and particularly in Wuhan, one of the most polluted cities in the world with a resulting epidemic of respiratory disease?? Three hundred thousand people get pneumonia in China every year and there are nearly a billion cases worldwide of 'flu-like symptoms'. These have a whole range of causes – including pollution in Wuhan – but no other possibility was credibly considered in late 2019 when the world was told there was a new and deadly 'virus'. The global prevalence of pneumonia and 'flu-like systems' gave the Cult networks unlimited potential to re-diagnose these other causes as the mythical 'Covid-19' and that is what they did from the very start. Kaufman revealed how Chinese medical and science authorities (all subordinates to the Cult-owned communist government) took genetic material from the lungs of only a few of the first patients. The material contained their own cells, bacteria, fungi and other microorganisms living in their bodies. The only way you could prove the existence of the 'virus' and its responsibility for the alleged 'Covid-19' was to isolate the virus from all the other material – a process also known as 'purification' – and

then follow the postulates sequence developed in the late 19th century by German physician and bacteriologist Robert Koch which became the 'gold standard' for connecting an alleged causation agent to a disease:

1. The microorganism (bacteria, fungus, virus, etc.) must be present in every case of the disease and all patients must have the same symptoms. It must also *not be present in healthy individuals*.
2. The microorganism must be isolated from the host with the disease. If the microorganism is a bacteria or fungus it must be grown in a pure culture. If it is a virus, it must be purified (i.e. containing no other material except the virus particles) from a clinical sample.
3. The specific disease, with all of its characteristics, must be reproduced when the infectious agent (the purified virus or a pure culture of bacteria or fungi) is inoculated into a healthy, susceptible host.
4. The microorganism must be recoverable from the experimentally infected host as in step 2.

*Not one* of these criteria has been met in the case of 'SARS-Cov-2' and 'Covid-19'. Not ONE. EVER. Robert Koch refers to bacteria and not viruses. What are called 'viral particles' are so minute (hence masks are useless by any definition) that they could only be seen after the invention of the electron microscope in the 1930s and can still only be observed through that means. American bacteriologist and virologist Thomas Milton Rivers, the so-called 'Father of Modern Virology' who was very significantly director of the Rockefeller Institute for Medical Research in the 1930s, developed a less stringent version of Koch's postulates to identify 'virus' causation known as 'Rivers criteria'. 'Covid' did not pass that process either. Some even doubt whether any 'virus' can be isolated from other particles containing genetic material in the Koch method. Freedom of Information requests in many countries asking for scientific proof that the 'Covid virus' has been purified and isolated and shown to exist have all come back with a 'we don't have that' and when this happened with a request to the UK Department of Health they added this comment:

However, outside of the scope of the [Freedom of Information Act] and on a discretionary basis, the following information has been advised to us, which may be of interest. Most infectious diseases are caused by viruses, bacteria or fungi. Some bacteria or fungi have the capacity to grow on their own in isolation, for example in colonies on a petri dish. Viruses are different in that they are what we call 'obligate pathogens' – that is, they cannot survive or reproduce without infecting a host ...

... For some diseases, it is possible to establish causation between a microorganism and a disease by isolating the pathogen from a patient, growing it in pure culture and reintroducing it to a healthy organism. These are known as 'Koch's postulates' and were developed in 1882. However, as our understanding of disease and different disease-causing agents has advanced, these are no longer the method for determining causation [Andrew Kaufman asks why in that case are there two published articles falsely claiming to satisfy Koch's postulates].

It has long been known that viral diseases cannot be identified in this way as viruses cannot be grown in 'pure culture'. When a patient is tested for a viral illness, this is normally done by looking for the presence of antigens, or viral genetic code in a host with molecular biology techniques [Kaufman asks how you could know the origin of these chemicals without having a pure culture for comparison].

For the record 'antigens' are defined so:

Invading microorganisms have antigens on their surface that the human body can recognise as being foreign – meaning not belonging to it. When the body recognises a foreign antigen, lymphocytes (white blood cells) produce antibodies, which are complementary in shape to the antigen.

Notwithstanding that this is open to question in relation to 'SARS-Cov-2' the presence of 'antibodies' can have many causes and they are found in people that are perfectly well. Kary Mullis said: 'Antibodies ... had always been considered evidence of past disease, not present disease.'

### **'Covid' really is a *computer* 'virus'**

Where the UK Department of Health statement says 'viruses' are now 'diagnosed' through a 'viral genetic code in a host with molecular biology techniques', they mean ... *the PCR test* which its inventor said cannot test for infectious disease. They have no credible method of connecting a 'virus' to a disease and we will see that there is no scientific proof that any 'virus' causes any disease or there is any such thing as a 'virus' in the way that it is described. Tenacious Canadian researcher Christine Massey and her team made

some 40 Freedom of Information requests to national public health agencies in different countries asking for proof that SARS-CoV-2 has been isolated and not one of them could supply that information. Massey said of her request in Canada: 'Freedom of Information reveals Public Health Agency of Canada has no record of 'SARS-COV-2' isolation performed by anyone, anywhere, ever.' If you accept the comment from the UK Department of Health it's because they can't isolate a 'virus'. Even so many 'science' papers claimed to have isolated the 'Covid virus' until they were questioned and had to admit they hadn't. A reply from the Robert Koch Institute in Germany was typical: 'I am not aware of a paper which purified isolated SARS-CoV-2.' So what the hell was Christian Drosten and his gang using to design the 'Covid' testing protocol that has produced all the illusory Covid' cases and 'Covid' deaths when the head of the Chinese version of the CDC admitted there was a problem right from the start in that the 'virus' had never been isolated/purified? Breathe deeply: What they are calling 'Covid' is actually created by a *computer program* i.e. *they made it up* – er, that's it. They took lung fluid, with many sources of genetic material, from one single person alleged to be infected with Covid-19 by a PCR test which they *claimed*, without clear evidence, contained a 'virus'. They used several computer programs to create a model of a theoretical virus genome sequence from more than fifty-six million small sequences of RNA, each of an unknown source, assembling them like a puzzle with no known solution. The computer filled in the gaps with sequences from bits in the gene bank to make it look like a bat SARS-like coronavirus! A wave of the magic wand and poof, an *in silico* (computer-generated) genome, a scientific fantasy, was created. UK health researcher Dr Kevin Corbett made the same point with this analogy:

... It's like giving you a few bones and saying that's your fish. It could be any fish. Not even a skeleton. Here's a few fragments of bones. That's your fish ... It's all from gene bank and the bits of the virus sequence that weren't there they made up.

They synthetically created them to fill in the blanks. That's what genetics is; it's a code. So it's ABBCCDDDD and you're missing some what you think is EEE so you put it in. It's all

synthetic. You just manufacture the bits that are missing. This is the end result of the geneticization of virology. This is basically a computer virus.

Further confirmation came in an email exchange between British citizen journalist Frances Leader and the government's Medicines & Healthcare Products Regulatory Agency (the Gates-funded MHRA) which gave emergency permission for untested 'Covid vaccines' to be used. The agency admitted that the 'vaccine' is not based on an isolated 'virus', but comes from a *computer-generated model*. Frances Leader was naturally banned from Cult-owned fascist Twitter for making this exchange public. The process of creating computer-generated alleged 'viruses' is called 'in silico' or 'in silicon' – computer chips – and the term 'in silico' is believed to originate with biological experiments using only a computer in 1989. 'Vaccines' involved with 'Covid' are also produced 'in silico' or by computer not a natural process. If the original 'virus' is nothing more than a made-up computer model how can there be 'new variants' of something that never existed in the first place? They are not new 'variants'; they are new *computer models* only minutely different to the original program and designed to further terrify the population into having the 'vaccine' and submitting to fascism. You want a 'new variant'? Click, click, enter – there you go. Tell the medical profession that you have discovered a 'South African variant', 'UK variants' or a 'Brazilian variant' and in the usual HIV-causes-AIDS manner they will unquestioningly repeat it with no evidence whatsoever to support these claims. They will go on television and warn about the dangers of 'new variants' while doing nothing more than repeating what they have been told to be true and knowing that any deviation from that would be career suicide. Big-time insiders will know it's a hoax, but much of the medical community is clueless about the way they are being played and themselves play the public without even being aware they are doing so. What an interesting 'coincidence' that AstraZeneca and Oxford University were conducting 'Covid vaccine trials' in the three countries – the UK, South Africa and Brazil – where the first three 'variants' were claimed to have 'broken out'.

## **Here's your 'virus' – it's a unicorn**

Dr Andrew Kaufman presented a brilliant analysis describing how the 'virus' was imagined into fake existence when he dissected an article published by *Nature* and written by 19 authors detailing *alleged* 'sequencing of a complete viral genome' of the 'new SARS-CoV-2 virus'. This computer-modelled *in silico* genome was used as a template for all subsequent genome sequencing experiments that resulted in the so-called variants which he said now number more than 6,000. The fake genome was constructed from more than 56 million individual short strands of RNA. Those little pieces were assembled into longer pieces by finding areas of overlapping sequences. The computer programs created over two million possible combinations from which the authors simply chose the longest one. They then compared this to a 'bat virus' and the computer 'alignment' rearranged the sequence and filled in the gaps! They called this computer-generated abomination the 'complete genome'. Dr Tom Cowan, a fellow medical author and collaborator with Kaufman, said such computer-generation constitutes scientific fraud and he makes this superb analogy:

Here is an equivalency: A group of researchers claim to have found a unicorn because they found a piece of a hoof, a hair from a tail, and a snippet of a horn. They then add that information into a computer and program it to re-create the unicorn, and they then claim this computer re-creation is the real unicorn. Of course, they had never actually seen a unicorn so could not possibly have examined its genetic makeup to compare their samples with the actual unicorn's hair, hooves and horn.

The researchers claim they decided which is the real genome of SARS-CoV-2 by 'consensus', sort of like a vote. Again, different computer programs will come up with different versions of the imaginary 'unicorn', so they come together as a group and decide which is the real imaginary unicorn.

This is how the 'virus' that has transformed the world was brought into fraudulent 'existence'. Extraordinary, yes, but as the Nazis said the bigger the lie the more will believe it. Cowan, however, wasn't finished and he went on to identify what he called the real blockbuster in the paper. He quotes this section from a paper written

by virologists and published by the CDC and then explains what it means:

Therefore, we examined the capacity of SARS-CoV-2 to infect and replicate in several common primate and human cell lines, including human adenocarcinoma cells (A549), human liver cells (HUH 7.0), and human embryonic kidney cells (HEK-293T). In addition to Vero E6 and Vero CCL81 cells. ... Each cell line was inoculated at high multiplicity of infection and examined 24h post-infection.

No CPE was observed in any of the cell lines except in Vero cells, which grew to greater than 10 to the 7th power at 24 h post-infection. In contrast, HUH 7.0 and 293T showed only modest viral replication, and A549 cells were incompatible with SARS CoV-2 infection.

Cowan explains that when virologists attempt to prove infection they have three possible 'hosts' or models on which they can test. The first was humans. Exposure to humans was generally not done for ethical reasons and has never been done with SARS-CoV-2 or any coronavirus. The second possible host was animals. Cowan said that forgetting for a moment that they never actually use purified virus when exposing animals they do use solutions that they *claim* contain the virus. Exposure to animals has been done with SARS-CoV-2 in an experiment involving mice and this is what they found: *None of the wild (normal) mice got sick.* In a group of genetically-modified mice, a statistically insignificant number lost weight and had slightly bristled fur, but they experienced nothing like the illness called 'Covid-19'. Cowan said the third method – the one they mostly rely on – is to inoculate solutions they *say* contain the virus onto a variety of tissue cultures. This process had never been shown to kill tissue *unless* the sample material was starved of nutrients and poisoned as *part of the process*. Yes, incredibly, in tissue experiments designed to show the 'virus' is responsible for killing the tissue they starve the tissue of nutrients and add toxic drugs including antibiotics and they do not have control studies to see if it's the starvation and poisoning that is degrading the tissue rather than the 'virus' they allege to be in there somewhere. You want me to pinch you? Yep, I understand. Tom Cowan said this about the whole nonsensical farce as he explains what that quote from the CDC paper really means:

The shocking thing about the above quote is that using their own methods, the virologists found that solutions containing SARS-CoV-2 – even in high amounts – were NOT, I repeat NOT, infective to any of the three human tissue cultures they tested. In plain English, this means they proved, on their terms, that this ‘new coronavirus’ is not infectious to human beings. It is ONLY infective to monkey kidney cells, and only then when you add two potent drugs (gentamicin and amphotericin), known to be toxic to kidneys, to the mix.

My friends, read this again and again. These virologists, published by the CDC, performed a clear proof, on their terms, showing that the SARS-CoV-2 virus is harmless to human beings. That is the only possible conclusion, but, unfortunately, this result is not even mentioned in their conclusion. They simply say they can provide virus stocks cultured only on monkey Vero cells, thanks for coming.

Cowan concluded: ‘If people really understood how this “science” was done, I would hope they would storm the gates and demand honesty, transparency and truth.’ Dr Michael Yeadon, former Vice President and Chief Scientific Adviser at drug giant Pfizer has been a vocal critic of the ‘Covid vaccine’ and its potential for multiple harm. He said in an interview in April, 2021, that ‘not one [vaccine] has the virus. He was asked why vaccines normally using a ‘dead’ version of a disease to activate the immune system were not used for ‘Covid’ and instead we had the synthetic methods of the ‘mRNA Covid vaccine’. Yeadon said that to do the former ‘you’d have to have some of [the virus] wouldn’t you?’ He added: ‘No-one’s got any – seriously.’ Yeadon said that surely they couldn’t have fooled the whole world for a year without having a virus, ‘but oddly enough ask around – no one’s got it’. He didn’t know why with all the ‘great labs’ around the world that the virus had not been isolated – ‘Maybe they’ve been too busy running bad PCR tests and vaccines that people don’t need.’ What is today called ‘science’ is not ‘science’ at all. Science is no longer what is, but whatever people can be manipulated to *believe* that it is. Real science has been hijacked by the Cult to dispense and produce the ‘expert scientists’ and contentions that suit the agenda of the Cult. How big-time this has happened with the ‘Covid’ hoax which is entirely based on fake science delivered by fake ‘scientists’ and fake ‘doctors’. The human-caused climate change hoax is also entirely based on fake science delivered by fake ‘scientists’ and fake ‘climate experts’. In both cases real



scientists, climate experts and doctors have their views suppressed and deleted by the Cult-owned science establishment, media and Silicon Valley. This is the 'science' that politicians claim to be 'following' and a common denominator of 'Covid' and climate are Cult psychopaths Bill Gates and his mate Klaus Schwab at the Gates-funded World Economic Forum. But, don't worry, it's all just a coincidence and absolutely nothing to worry about. Zzzzzzzzz.

## **What is a 'virus' REALLY?**

Dr Tom Cowan is one of many contesting the very existence of viruses let alone that they cause disease. This is understandable when there is no scientific evidence for a disease-causing 'virus'. German virologist Dr Stefan Lanka won a landmark case in 2017 in the German Supreme Court over his contention that there is no such thing as a measles virus. He had offered a big prize for anyone who could prove there is and Lanka won his case when someone sought to claim the money. There is currently a prize of more than 225,000 euros on offer from an Isolate Truth Fund for anyone who can prove the isolation of SARS-CoV-2 and its genetic substance. Lanka wrote in an article headed 'The Misconception Called Virus' that scientists think a 'virus' is causing tissue to become diseased and degraded when in fact it is the *processes they are using* which do that – not a 'virus'. Lanka has done an important job in making this point clear as Cowan did in his analysis of the CDC paper. Lanka says that all claims about viruses as disease-causing pathogens are wrong and based on 'easily recognisable, understandable and verifiable misinterpretations.' Scientists believed they were working with 'viruses' in their laboratories when they were really working with 'typical particles of specific dying tissues or cells ...' Lanka said that the tissue decaying process claimed to be caused by a 'virus' still happens when no alleged 'virus' is involved. It's the *process* that does the damage and not a 'virus'. The genetic sample is deprived of nutrients, removed from its energy supply through removal from the body and then doused in toxic antibiotics to remove any bacteria. He confirms again that establishment scientists do not (pinch me)

conduct control experiments to see if this is the case and if they did they would see the claims that 'viruses' are doing the damage is nonsense. He adds that during the measles 'virus' court case he commissioned an independent laboratory to perform just such a control experiment and the result was that the tissues and cells died in the exact same way as with alleged 'infected' material. This is supported by a gathering number of scientists, doctors and researchers who reject what is called 'germ theory' or the belief in the body being infected by contagious sources emitted by other people. Researchers Dawn Lester and David Parker take the same stance in their highly-detailed and sourced book *What Really Makes You Ill – Why everything you thought you knew about disease is wrong* which was recommended to me by a number of medical professionals genuinely seeking the truth. Lester and Parker say there is no provable scientific evidence to show that a 'virus' can be transmitted between people or people and animals or animals and people:

The definition also claims that viruses are the cause of many diseases, as if this has been definitively proven. But this is not the case; there is no original scientific evidence that definitively demonstrates that any virus is the cause of any disease. The burden of proof for any theory lies with those who proposed it; but none of the existing documents provides 'proof' that supports the claim that 'viruses' are pathogens.

Dr Tom Cowan employs one of his clever analogies to describe the process by which a 'virus' is named as the culprit for a disease when what is called a 'virus' is only material released by cells detoxing themselves from infiltration by chemical or radiation poisoning. The tidal wave of technologically-generated radiation in the 'smart' modern world plus all the toxic food and drink are causing this to happen more than ever. Deluded 'scientists' misread this as a gathering impact of what they wrongly label 'viruses'.

### **Paper can infect houses**

Cowan said in an article for [davidicke.com](http://davidicke.com) – with his tongue only mildly in his cheek – that he believed he had made a tremendous

discovery that may revolutionise science. He had discovered that small bits of paper are alive, 'well alive-ish', can 'infect' houses, and then reproduce themselves inside the house. The result was that this explosion of growth in the paper inside the house causes the house to explode, blowing it to smithereens. His evidence for this new theory is that in the past months he had carefully examined many of the houses in his neighbourhood and found almost no scraps of paper on the lawns and surrounds of the house. There was an occasional stray label, but nothing more. Then he would return to these same houses a week or so later and with a few, not all of them, particularly the old and decrepit ones, he found to his shock and surprise they were littered with stray bits of paper. He knew then that the paper had infected these houses, made copies of itself, and blew up the house. A young boy on a bicycle at one of the sites told him he had seen a demolition crew using dynamite to explode the house the previous week, but Cowan dismissed this as the idle thoughts of silly boys because 'I was on to something big'. He was on to how 'scientists' mistake genetic material in the detoxifying process for something they call a 'virus'. Cowan said of his house and paper story:

If this sounds crazy to you, it's because it should. This scenario is obviously nuts. But consider this admittedly embellished, for effect, current viral theory that all scientists, medical doctors and virologists currently believe.

He takes the example of the 'novel SARS-Cov2' virus to prove the point. First they take someone with an undefined illness called 'Covid-19' and don't even attempt to find any virus in their sputum. Never mind the scientists still describe how this 'virus', which they have not located attaches to a cell receptor, injects its genetic material, in 'Covid's' case, RNA, into the cell. The RNA once inserted exploits the cell to reproduce itself and makes 'thousands, nay millions, of copies of itself ... Then it emerges victorious to claim its next victim':

If you were to look in the scientific literature for proof, actual scientific proof, that uniform SARS-CoV2 viruses have been properly isolated from the sputum of a sick person, that actual spike proteins could be seen protruding from the virus (which has not been found), you would find that such evidence doesn't exist.

If you go looking in the published scientific literature for actual pictures, proof, that these spike proteins or any viral proteins are ever attached to any receptor embedded in any cell membrane, you would also find that no such evidence exists. If you were to look for a video or documented evidence of the intact virus injecting its genetic material into the body of the cell, reproducing itself and then emerging victorious by budding off the cell membrane, you would find that no such evidence exists.

The closest thing you would find is electron micrograph pictures of cellular particles, possibly attached to cell debris, both of which to be seen were stained by heavy metals, a process that completely distorts their architecture within the living organism. This is like finding bits of paper stuck to the blown-up bricks, thereby proving the paper emerged by taking pieces of the bricks on its way out.

## **The Enders baloney**

Cowan describes the 'Covid' story as being just as make-believe as his paper story and he charts back this fantasy to a Nobel Prize winner called John Enders (1897-1985), an American biomedical scientist who has been dubbed 'The Father of Modern Vaccines'. Enders is claimed to have 'discovered' the process of the viral culture which 'proved' that a 'virus' caused measles. Cowan explains how Enders did this 'by using the EXACT same procedure that has been followed by every virologist to find and characterize every new virus since 1954'. Enders took throat swabs from children with measles and immersed them in 2ml of milk. Penicillin (100u/ml) and the antibiotic streptomycin (50,g/ml) were added and the whole mix was centrifuged – rotated at high speed to separate large cellular debris from small particles and molecules as with milk and cream, for example. Cowan says that if the aim is to find little particles of genetic material ('viruses') in the snot from children with measles it would seem that the last thing you would do is mix the snot with other material – milk –that also has genetic material. 'How are you ever going to know whether whatever you found came from the snot or the milk?' He points out that streptomycin is a 'nephrotoxic' or poisonous-to-the-kidney drug. You will see the relevance of that

shortly. Cowan says that it gets worse, much worse, when Enders describes the culture medium upon which the virus 'grows': 'The culture medium consisted of bovine amniotic fluid (90%), beef embryo extract (5%), horse serum (5%), antibiotics and phenol red as an indicator of cell metabolism.' Cowan asks incredulously: 'Did he just say that the culture medium also contained fluids and tissues that are themselves rich sources of genetic material?' The genetic cocktail, or 'medium', is inoculated onto tissue and cells from rhesus monkey *kidney* tissue. This is where the importance of streptomycin comes in and currently-used antimicrobials and other drugs that are *poisonous to kidneys* and used in ALL modern viral cultures (e.g. gentamicin, streptomycin, and amphotericin). Cowan asks: 'How are you ever going to know from this witch's brew where any genetic material comes from as we now have five different sources of rich genetic material in our mix?' Remember, he says, that all genetic material, whether from monkey kidney tissues, bovine serum, milk, etc., is made from the exact same components. The same central question returns: 'How are you possibly going to know that it was the virus that killed the kidney tissue and not the toxic antibiotic and starvation rations on which you are growing the tissue?' John Enders answered the question himself – *you can't*:

A second agent was obtained from an uninoculated culture of monkey kidney cells. The cytopathic changes [death of the cells] it induced in the unstained preparations could not be distinguished with confidence from the viruses isolated from measles.

The death of the cells ('cytopathic changes') happened in exactly the same manner, whether they inoculated the kidney tissue with the measles snot or not, Cowan says. 'This is evidence that the destruction of the tissue, the very proof of viral causation of illness, was not caused by anything in the snot because they saw the same destructive effect when the snot was not even used ... the cytopathic, i.e., cell-killing, changes come from the process of the culture itself, not from any virus in any snot, period.' Enders quotes in his 1957 paper a virologist called Ruckle as reporting similar findings 'and in addition has isolated an agent from monkey kidney tissue that is so

far indistinguishable from human measles virus'. In other words, Cowan says, these particles called 'measles viruses' are simply and clearly breakdown products of the starved and poisoned tissue. For measles 'virus' see all 'viruses' including the so-called 'Covid virus'. Enders, the 'Father of Modern Vaccines', also said:

There is a potential risk in employing cultures of primate cells for the production of vaccines composed of attenuated virus, since the presence of other agents possibly latent in primate tissues cannot be definitely excluded by any known method.

Cowan further quotes from a paper published in the journal *Viruses* in May, 2020, while the 'Covid pandemic' was well underway in the media if not in reality. 'EVs' here refers to particles of genetic debris from our own tissues, such as exosomes of which more in a moment: 'The remarkable resemblance between EVs and viruses has caused quite a few problems in the studies focused on the analysis of EVs released during viral infections.' Later the paper adds that to date a reliable method that can actually guarantee a complete separation (of EVs from viruses) DOES NOT EXIST. This was published at a time when a fairy tale 'virus' was claimed in total certainty to be causing a fairy tale 'viral disease' called 'Covid-19' – a fairy tale that was already well on the way to transforming human society in the image that the Cult has worked to achieve for so long. Cowan concludes his article:

To summarize, there is no scientific evidence that pathogenic viruses exist. What we think of as 'viruses' are simply the normal breakdown products of dead and dying tissues and cells. When we are well, we make fewer of these particles; when we are starved, poisoned, suffocated by wearing masks, or afraid, we make more.

There is no engineered virus circulating and making people sick. People in laboratories all over the world are making genetically modified products to make people sick. These are called vaccines. There is no virome, no 'ecosystem' of viruses, viruses are not 8%, 50% or 100 % of our genetic material. These are all simply erroneous ideas based on the misconception called a virus.

## **What is 'Covid'? Load of bollocks**

The background described here by Cowan and Lanka was emphasised in the first video presentation that I saw by Dr Andrew Kaufman when he asked whether the 'Covid virus' was in truth a natural defence mechanism of the body called 'exosomes'. These are released by cells when in states of toxicity – see the same themes returning over and over. They are released ever more profusely as chemical and radiation toxicity increases and think of the potential effect therefore of 5G alone as its destructive frequencies infest the human energetic information field with a gathering pace (5G went online in Wuhan in 2019 as the 'virus' emerged). I'll have more about this later. Exosomes transmit a warning to the rest of the body that 'Houston, we have a problem'. Kaufman presented images of exosomes and compared them with 'Covid' under an electron microscope and the similarity was remarkable. They both attach to the same cell receptors (*claimed* in the case of 'Covid'), contain the same genetic material in the form of RNA or ribonucleic acid, and both are found in 'viral cell cultures' with damaged or dying cells. James Hildreth MD, President and Chief Executive Officer of the Meharry Medical College at Johns Hopkins, said: 'The virus is fully an exosome in every sense of the word.' Kaufman's conclusion was that there is no 'virus': 'This entire pandemic is a completely manufactured crisis ... there is no evidence of anyone dying from [this] illness.' Dr Tom Cowan and Sally Fallon Morell, authors of *The Contagion Myth*, published a statement with Dr Kaufman in February, 2021, explaining why the 'virus' does not exist and you can read it that in full in the Appendix.

'Virus' theory can be traced to the 'cell theory' in 1858 of German physician Rudolf Virchow (1821-1920) who contended that disease originates from a single cell infiltrated by a 'virus'. Dr Stefan Lanka said that findings and insights with respect to the structure, function and central importance of tissues in the creation of life, which were already known in 1858, comprehensively refute the cell theory. Virchow ignored them. We have seen the part later played by John Enders in the 1950s and Lanka notes that infection theories were only established as a global dogma through the policies and

eugenics of the Third Reich in Nazi Germany (creation of the same Sabbatian cult behind the 'Covid' hoax). Lanka said: 'Before 1933, scientists dared to contradict this theory; after 1933, these critical scientists were silenced'. Dr Tom Cowan's view is that ill-health is caused by too much of something, too little of something, or toxification from chemicals and radiation – not contagion. We must also highlight as a major source of the 'virus' theology a man still called the 'Father of Modern Virology' – Thomas Milton Rivers (1888-1962). There is no way given the Cult's long game policy that it was a coincidence for the 'Father of Modern Virology' to be director of the Rockefeller Institute for Medical Research from 1937 to 1956 when he is credited with making the Rockefeller Institute a leader in 'viral research'. Cult Rockefeller were the force behind the creation of Big Pharma 'medicine', established the World Health Organisation in 1948, and have long and close associations with the Gates family that now runs the WHO during the pandemic hoax through mega-rich Cult gofer and psychopath Bill Gates.

Only a Renegade Mind can see through all this bullshit by asking the questions that need to be answered, not taking 'no' or prevarication for an answer, and certainly not hiding from the truth in fear of speaking it. Renegade Minds have always changed the world for the better and they will change this one no matter how bleak it may currently appear to be.



## CHAPTER SIX

### **Sequence of deceit**

*If you tell the truth, you don't have to remember anything*  
Mark Twain

**A**gainst the background that I have laid out this far the sequence that took us from an invented 'virus' in Cult-owned China in late 2019 to the fascist transformation of human society can be seen and understood in a whole new context.

We were told that a deadly disease had broken out in Wuhan and the world media began its campaign (coordinated by behavioural psychologists as we shall see) to terrify the population into unquestioning compliance. We were shown images of Chinese people collapsing in the street which never happened in the West with what was supposed to be the same condition. In the earliest days when alleged cases and deaths were few the fear register was hysterical in many areas of the media and this would expand into the common media narrative across the world. The real story was rather different, but we were never told that. The Chinese government, one of the Cult's biggest centres of global operation, said they had discovered a new illness with flu-like and pneumonia-type symptoms in a city with such toxic air that it is overwhelmed with flu-like symptoms, pneumonia and respiratory disease. Chinese scientists said it was a new – 'novel' – coronavirus which they called Sars-Cov-2 and that it caused a disease they labelled 'Covid-19'. There was no evidence for this and the 'virus' has never to this day been isolated, purified and its genetic code established from that. It

was from the beginning a computer-generated fiction. Stories of Chinese whistleblowers saying the number of deaths was being suppressed or that the 'new disease' was related to the Wuhan bio-lab misdirected mainstream and alternative media into cul-de-sacs to obscure the real truth – there was no 'virus'.

Chinese scientists took genetic material from the lung fluid of just a few people and said they had found a 'new' disease when this material had a wide range of content. There was no evidence for a 'virus' for the very reasons explained in the last two chapters. The 'virus' has never been shown to (a) exist and (b) cause any disease. People were diagnosed on symptoms that are so widespread in Wuhan and polluted China and with a PCR test that can't detect infectious disease. On this farce the whole global scam was sold to the rest of the world which would also diagnose respiratory disease as 'Covid-19' from symptoms alone or with a PCR test not testing for a 'virus'. Flu miraculously disappeared *worldwide* in 2020 and into 2021 as it was redesignated 'Covid-19'. It was really the same old flu with its 'flu-like' symptoms attributed to 'flu-like' 'Covid-19'. At the same time with very few exceptions the Chinese response of draconian lockdown and fascism was the chosen weapon to respond across the West as recommended by the Cult-owned Tedros at the Cult-owned World Health Organization run by the Cult-owned Gates. All was going according to plan. Chinese scientists – everything in China is controlled by the Cult-owned government – compared their contaminated RNA lung-fluid material with other RNA sequences and said it appeared to be just under 80 percent identical to the SARS-CoV-1 'virus' claimed to be the cause of the SARS (severe acute respiratory syndrome) 'outbreak' in 2003. They decreed that because of this the 'new virus' had to be related and they called it SARS-CoV-2. There are some serious problems with this assumption and *assumption* was all it was. Most 'factual' science turns out to be assumptions repeated into everyone-knows-that. A match of under 80-percent is meaningless. Dr Kaufman makes the point that there's a 96 percent genetic correlation between humans and chimpanzees, but 'no one would say our genetic material is part

of the chimpanzee family'. Yet the Chinese authorities were claiming that a much lower percentage, less than 80 percent, proved the existence of a new 'coronavirus'. For goodness sake human DNA is 60 percent similar to a *banana*.

## **You are feeling sleepy**

The entire 'Covid' hoax is a global Psyop, a psychological operation to program the human mind into believing and fearing a complete fantasy. A crucial aspect of this was what *appeared* to happen in Italy. It was all very well streaming out daily images of an alleged catastrophe in Wuhan, but to the Western mind it was still on the other side of the world in a very different culture and setting. A reaction of 'this could happen to me and my family' was still nothing like as intense enough for the mind-doctors. The Cult needed a Western example to push people over that edge and it chose Italy, one of its major global locations going back to the Roman Empire. An Italian 'Covid' crisis was manufactured in a particular area called Lombardy which just happens to be notorious for its toxic air and therefore respiratory disease. Wuhan, China, *déjà vu*. An hysterical media told horror stories of Italians dying from 'Covid' in their droves and how Lombardy hospitals were being overrun by a tidal wave of desperately ill people needing treatment after being struck down by the 'deadly virus'. Here was the psychological turning point the Cult had planned. Wow, if this is happening in Italy, the Western mind concluded, this indeed could happen to me and my family. Another point is that Italian authorities responded by following the Chinese blueprint so vehemently recommended by the Cult-owned World Health Organization. They imposed fascistic lockdowns on the whole country viciously policed with the help of surveillance drones sweeping through the streets seeking out anyone who escaped from mass house arrest. Livelihoods were destroyed and psychology unravelled in the way we have witnessed since in all lockdown countries. Crucial to the plan was that Italy responded in this way to set the precedent of suspending freedom and imposing fascism in a 'Western liberal democracy'. I emphasised in an

animated video explanation on [davidicke.com](http://davidicke.com) posted in the summer of 2020 how important it was to the Cult to expand the Chinese lockdown model across the West. Without this, and the bare-faced lie that non-symptomatic people could still transmit a 'disease' they didn't have, there was no way locking down the whole population, sick and not sick, could be pulled off. At just the right time and with no evidence Cult operatives and gofers claimed that people without symptoms could pass on the 'disease'. In the name of protecting the 'vulnerable' like elderly people, who lockdowns would kill by the tens of thousands, we had for the first time healthy people told to isolate as well as the sick. The great majority of people who tested positive had no symptoms because there was nothing wrong with them. It was just a trick made possible by a test not testing for the 'virus'.

Months after my animated video the Gates-funded Professor Neil Ferguson at the Gates-funded Imperial College confirmed that I was right. He didn't say it in those terms, naturally, but he did say it. Ferguson will enter the story shortly for his outrageously crazy 'computer models' that led to Britain, the United States and many other countries following the Chinese and now Italian methods of response. Put another way, following the Cult script. Ferguson said that SAGE, the UK government's scientific advisory group which has controlled 'Covid' policy from the start, wanted to follow the Chinese lockdown model (while they all continued to work and be paid), but they wondered if they could possibly, in Ferguson's words, 'get away with it in Europe'. 'Get away with it'? Who the hell do these moronic, arrogant people think they are? This appalling man Ferguson said that once Italy went into national lockdown they realised they, too, could mimic China:

It's a communist one-party state, we said. We couldn't get away with it in Europe, we thought ... and then Italy did it. And we realised we could. Behind this garbage from Ferguson is a simple fact: Doing the same as China in every country was the plan from the start and Ferguson's 'models' would play a central role in achieving that. It's just a coincidence, of course, and absolutely nothing to worry your little head about.

## **Oops, sorry, our mistake**

Once the Italian segment of the Psyop had done the job it was designed to do a very different story emerged. Italian authorities revealed that 99 percent of those who had 'died from Covid-19' in Italy had one, two, three, or more 'co-morbidities' or illnesses and health problems that could have ended their life. The US Centers for Disease Control and Prevention (CDC) published a figure of 94 percent for Americans dying of 'Covid' while having other serious medical conditions – on average two to three (some five or six) other potential causes of death. In terms of death from an unproven 'virus' I say it is 100 percent. The other one percent in Italy and six percent in the US would presumably have died from 'Covid's' flu-like symptoms with a range of other possible causes in conjunction with a test not testing for the 'virus'. Fox News reported that even more startling figures had emerged in one US county in which 410 of 422 deaths attributed to 'Covid-19' had other potentially deadly health conditions. The Italian National Health Institute said later that the average age of people dying with a 'Covid-19' diagnosis in Italy was about 81. Ninety percent were over 70 with ten percent over 90. In terms of other reasons to die some 80 percent had two or more chronic diseases with half having three or more including cardiovascular problems, diabetes, respiratory problems and cancer. Why is the phantom 'Covid-19' said to kill overwhelmingly old people and hardly affect the young? Old people continually die of many causes and especially respiratory disease which you can re-diagnose 'Covid-19' while young people die in tiny numbers by comparison and rarely of respiratory disease. Old people 'die of Covid' because they die of other things that can be redesignated 'Covid' and it really is that simple.

## **Flu has flown**

The blueprint was in place. Get your illusory 'cases' from a test not testing for the 'virus' and redesignate other causes of death as 'Covid-19'. You have an instant 'pandemic' from something that is nothing more than a computer-generated fiction. With near-on a

billion people having 'flu-like' symptoms every year the potential was limitless and we can see why flu quickly and apparently miraculously disappeared *worldwide* by being diagnosed 'Covid-19'. The painfully bloody obvious was explained away by the childlike media in headlines like this in the UK '*Independent*': 'Not a single case of flu detected by Public Health England this year as Covid restrictions suppress virus'. I kid you not. The masking, social distancing and house arrest that did not make the 'Covid virus' disappear somehow did so with the 'flu virus'. Even worse the article, by a bloke called Samuel Lovett, suggested that maybe the masking, sanitising and other 'Covid' measures should continue to keep the flu away. With a ridiculousness that disturbs your breathing (it's 'Covid-19') the said Lovett wrote: 'With widespread social distancing and mask-wearing measures in place throughout the UK, the usual routes of transmission for influenza have been blocked.' He had absolutely no evidence to support that statement, but look at the consequences of him acknowledging the obvious. With flu not disappearing at all and only being relabelled 'Covid-19' he would have to contemplate that 'Covid' was a hoax on a scale that is hard to imagine. You need guts and commitment to truth to even go there and that's clearly something Samuel Lovett does not have in abundance. He would never have got it through the editors anyway.

Tens of thousands die in the United States alone every winter from flu including many with pneumonia complications. CDC figures record *45 million* Americans diagnosed with flu in 2017-2018 of which 61,000 died and some reports claim 80,000. Where was the same hysteria then that we have seen with 'Covid-19'? Some 250,000 Americans are admitted to hospital with pneumonia every year with about 50,000 cases proving fatal. About 65 million suffer respiratory disease every year and three million deaths makes this the third biggest cause of death worldwide. You only have to redesignate a portion of all these people 'Covid-19' and you have an instant global pandemic or the *appearance* of one. Why would doctors do this? They are told to do this and all but a few dare not refuse those who must be obeyed. Doctors in general are not researching their own

knowledge and instead take it direct and unquestioned from the authorities that own them and their careers. The authorities say they must now diagnose these symptoms 'Covid-19' and not flu, or whatever, and they do it. Dark suits say put 'Covid-19' on death certificates no matter what the cause of death and the doctors do it. Renegade Minds don't fall for the illusion that doctors and medical staff are all highly-intelligent, highly-principled, seekers of medical truth. *Some are*, but not the majority. They are repeaters, gofers, and yes sir, no sir, purveyors of what the system demands they purvey. The 'Covid' con is not merely confined to diseases of the lungs. Instructions to doctors to put 'Covid-19' on death certificates for anyone dying of *anything* within 28 days (or much more) of a positive test not testing for the 'virus' opened the floodgates. The term dying *with* 'Covid' and not *of* 'Covid' was coined to cover the truth. Whether it was a *with* or an *of* they were all added to the death numbers attributed to the 'deadly virus' compiled by national governments and globally by the Gates-funded Johns Hopkins operation in the United States that was so involved in those 'pandemic' simulations. Fraudulent deaths were added to the ever-growing list of fraudulent 'cases' from false positives from a false test. No wonder Professor Walter Ricciardi, scientific advisor to the Italian minister of health, said after the Lombardy hysteria had done its job that 'Covid' death rates were due to Italy having the second oldest population in the world and to *how hospitals record deaths*:

The way in which we code deaths in our country is very generous in the sense that all the people who die in hospitals with the coronavirus are deemed to be dying of the coronavirus. On re-evaluation by the National Institute of Health, only 12 per cent of death certificates have shown a direct causality from coronavirus, while 88 per cent of patients who have died have at least one pre-morbidity – many had two or three.

This is extraordinary enough when you consider the propaganda campaign to use Italy to terrify the world, but how can they even say twelve percent were genuine when the 'virus' has not been shown to exist, its 'code' is a computer program, and diagnosis comes from a test not testing for it? As in China, and soon the world, 'Covid-19' in

Italy was a redesignation of diagnosis. Lies and corruption were to become the real 'pandemic' fuelled by a pathetically-compliant medical system taking its orders from the tiny few at the top of their national hierarchy who answered to the World Health Organization which answers to Gates and the Cult. Doctors were told – ordered – to diagnose a particular set of symptoms 'Covid-19' and put that on the death certificate for any cause of death if the patient had tested positive with a test not testing for the virus or had 'Covid' symptoms like the flu. The United States even introduced big financial incentives to manipulate the figures with hospitals receiving £4,600 from the Medicare system for diagnosing someone with regular pneumonia, \$13,000 if they made the diagnosis from the same symptoms 'Covid-19' pneumonia, and \$39,000 if they put a 'Covid' diagnosed patient on a ventilator that would almost certainly kill them. A few – painfully and pathetically few – medical whistleblowers revealed (before Cult-owned YouTube deleted their videos) that they had been instructed to 'let the patient crash' and put them straight on a ventilator instead of going through a series of far less intrusive and dangerous methods as they would have done before the pandemic hoax began and the financial incentives kicked in. We are talking cold-blooded murder given that ventilators are so damaging to respiratory systems they are usually the last step before heaven awaits. Renegade Minds never fall for the belief that people in white coats are all angels of mercy and cannot be full-on psychopaths. I have explained in detail in *The Answer* how what I am describing here played out across the world coordinated by the World Health Organization through the medical hierarchies in almost every country.

### **Medical scientist calls it**

Information about the non-existence of the 'virus' began to emerge for me in late March, 2020, and mushroomed after that. I was sent an email by Sir Julian Rose, a writer, researcher, and organic farming promotor, from a medical scientist friend of his in the United States. Even at that early stage in March the scientist was able to explain



how the 'Covid' hoax was being manipulated. He said there were no reliable tests for a specific 'Covid-19 virus' and nor were there any reliable agencies or media outlets for reporting numbers of actual 'Covid-19' cases. We have seen in the long period since then that he was absolutely right. 'Every action and reaction to Covid-19 is based on totally flawed data and we simply cannot make accurate assessments,' he said. Most people diagnosed with 'Covid-19' were showing nothing more than cold and flu-like symptoms 'because most coronavirus strains *are* nothing more than cold/flu-like symptoms'. We had farcical situations like an 84-year-old German man testing positive for 'Covid-19' and his nursing home ordered to quarantine only for him to be found to have a common cold. The scientist described back then why PCR tests and what he called the 'Mickey Mouse test kits' were useless for what they were claimed to be identifying. 'The idea these kits can isolate a specific virus like Covid-19 is nonsense,' he said. Significantly, he pointed out that 'if you want to create a totally false panic about a totally false pandemic – pick a coronavirus'. This is exactly what the Cult-owned Gates, World Economic Forum and Johns Hopkins University did with their Event 201 'simulation' followed by their real-life simulation called the 'pandemic'. The scientist said that all you had to do was select the sickest of people with respiratory-type diseases in a single location – 'say Wuhan' – and administer PCR tests to them. You can then claim that anyone showing 'viral sequences' similar to a coronavirus 'which will inevitably be quite a few' is suffering from a 'new' disease:

Since you already selected the sickest flu cases a fairly high proportion of your sample will go on to die. You can then say this 'new' virus has a CFR [case fatality rate] higher than the flu and use this to infuse more concern and do more tests which will of course produce more 'cases', which expands the testing, which produces yet more 'cases' and so on and so on. Before long you have your 'pandemic', and all you have done is use a simple test kit trick to convert the worst flu and pneumonia cases into something new that doesn't ACTUALLY EXIST [my emphasis].

He said that you then 'just run the same scam in other countries' and make sure to keep the fear message running high 'so that people

will feel panicky and less able to think critically'. The only problem to overcome was the fact *there is no* actual new deadly pathogen and only regular sick people. This meant that deaths from the 'new deadly pathogen' were going to be way too low for a real new deadly virus pandemic, but he said this could be overcome in the following ways – all of which would go on to happen:

1. You can claim this is just the beginning and more deaths are imminent [you underpin this with fantasy 'computer projections']. Use this as an excuse to quarantine everyone and then claim the quarantine prevented the expected millions of dead.
2. You can [say that people] 'minimizing' the dangers are irresponsible and bully them into not talking about numbers.
3. You can talk crap about made up numbers hoping to blind people with pseudoscience.
4. You can start testing well people (who, of course, will also likely have shreds of coronavirus [RNA] in them) and thus inflate your 'case figures' with 'asymptomatic carriers' (you will of course have to spin that to sound deadly even though any virologist knows the more symptom-less cases you have the less deadly is your pathogen).

The scientist said that if you take these simple steps 'you can have your own entirely manufactured pandemic up and running in weeks'. His analysis made so early in the hoax was brilliantly prophetic of what would actually unfold. Pulling all the information together in these recent chapters we have this is simple 1, 2, 3, of how you can delude virtually the entire human population into believing in a 'virus' that doesn't exist:

- A 'Covid case' is someone who tests positive with a test not testing for the 'virus'.
- A 'Covid death' is someone who dies of *any cause* within 28 days (or much longer) of testing positive with a test not testing for the 'virus'.
- Asymptomatic means there is nothing wrong with you, but they claim you can pass on what you don't have to justify locking

down (quarantining) healthy people in totality.

The foundations of the hoax are that simple. A study involving ten million people in Wuhan, published in November, 2020, demolished the whole lie about those without symptoms passing on the 'virus'. They found '300 asymptomatic cases' and traced their contacts to find that not one of them was detected with the 'virus'.

'Asymptomatic' patients and their contacts were isolated for no less than two weeks and nothing changed. I know it's all crap, but if you are going to claim that those without symptoms can transmit 'the virus' then you must produce evidence for that and they never have. Even World Health Organization official Dr Maria Van Kerkhove, head of the emerging diseases and zoonosis unit, said as early as June, 2020, that she doubted the validity of asymptomatic transmission. She said that 'from the data we have, it still seems to be rare that an asymptomatic person actually transmits onward to a secondary individual' and by 'rare' she meant that she couldn't cite any case of asymptomatic transmission.

### **The Ferguson factor**

The problem for the Cult as it headed into March, 2020, when the script had lockdown due to start, was that despite all the manipulation of the case and death figures they still did not have enough people alleged to have died from 'Covid' to justify mass house arrest. This was overcome in the way the scientist described: 'You can claim this is just the beginning and more deaths are imminent ... Use this as an excuse to quarantine everyone and then claim the quarantine prevented the expected millions of dead.' Enter one Professor Neil Ferguson, the Gates-funded 'epidemiologist' at the Gates-funded Imperial College in London. Ferguson is Britain's Christian Drosten in that he has a dire record of predicting health outcomes, but is still called upon to advise government on the next health outcome when another 'crisis' comes along. This may seem to be a strange and ridiculous thing to do. Why would you keep turning for policy guidance to people who have a history of being

monumentally wrong? Ah, but it makes sense from the Cult point of view. These 'experts' keep on producing predictions that suit the Cult agenda for societal transformation and so it was with Neil Ferguson as he revealed his horrific (and clearly insane) computer model predictions that allowed lockdowns to be imposed in Britain, the United States and many other countries. Ferguson does not have even an A-level in biology and would appear to have no formal training in computer modelling, medicine or epidemiology, according to Derek Winton, an MSc in Computational Intelligence. He wrote an article somewhat aghast at what Ferguson did which included taking no account of respiratory disease 'seasonality' which means it is far worse in the winter months. Who would have thought that respiratory disease could be worse in the winter? Well, certainly not Ferguson.

The massively China-connected Imperial College and its bizarre professor provided the excuse for the long-incubated Chinese model of human control to travel westward at lightning speed. Imperial College confirms on its website that it collaborates with the Chinese Research Institute; publishes more than 600 research papers every year with Chinese research institutions; has 225 Chinese staff; 2,600 Chinese students – the biggest international group; 7,000 former students living in China which is the largest group outside the UK; and was selected for a tour by China's President Xi Jinping during his state visit to the UK in 2015. The college takes major donations from China and describes itself as the UK's number one university collaborator with Chinese research institutions. The China communist/fascist government did not appear phased by the woeful predictions of Ferguson and Imperial when during the lockdown that Ferguson induced the college signed a five-year collaboration deal with China tech giant Huawei that will have Huawei's indoor 5G network equipment installed at the college's West London tech campus along with an 'AI cloud platform'. The deal includes Chinese sponsorship of Imperial's Venture Catalyst entrepreneurship competition. Imperial is an example of the enormous influence the Chinese government has within British and North American

universities and research centres – and further afield. Up to 200 academics from more than a dozen UK universities are being investigated on suspicion of ‘unintentionally’ helping the Chinese government build weapons of mass destruction by ‘transferring world-leading research in advanced military technology such as aircraft, missile designs and cyberweapons’. Similar scandals have broken in the United States, but it’s all a coincidence. Imperial College serves the agenda in many other ways including the promotion of every aspect of the United Nations Agenda 21/2030 (the Great Reset) and produced computer models to show that human-caused ‘climate change’ is happening when in the real world it isn’t. Imperial College is driving the climate agenda as it drives the ‘Covid’ agenda (both Cult hoaxes) while Patrick Vallance, the UK government’s Chief Scientific Adviser on ‘Covid’, was named Chief Scientific Adviser to the UN ‘climate change’ conference known as COP26 hosted by the government in Glasgow, Scotland. ‘Covid’ and ‘climate’ are fundamentally connected.

## **Professor Woeful**

From Imperial’s bosom came Neil Ferguson still advising government despite his previous disasters and it was announced early on that he and other key people like UK Chief Medical Adviser Chris Whitty had caught the ‘virus’ as the propaganda story was being sold. Somehow they managed to survive and we had Prime Minister Boris Johnson admitted to hospital with what was said to be a severe version of the ‘virus’ in this same period. His whole policy and demeanour changed when he returned to Downing Street. It’s a small world with these government advisors – especially in their communal connections to Gates – and Ferguson had partnered with Whitty to write a paper called ‘Infectious disease: Tough choices to reduce Ebola transmission’ which involved another scare-story that didn’t happen. Ferguson’s ‘models’ predicted that up to 150,000 could die from ‘mad cow disease’, or BSE, and its version in sheep if it was transmitted to humans. BSE was not transmitted and instead triggered by an organophosphate pesticide used to treat a pest on

cows. Fewer than 200 deaths followed from the human form. Models by Ferguson and his fellow incompetents led to the unnecessary culling of millions of pigs, cattle and sheep in the foot and mouth outbreak in 2001 which destroyed the lives and livelihoods of farmers and their families who had often spent decades building their herds and flocks. Vast numbers of these animals did not have foot and mouth and had no contact with the infection. Another 'expert' behind the cull was Professor Roy Anderson, a computer modeller at Imperial College specialising in the epidemiology of *human*, not animal, disease. Anderson has served on the Bill and Melinda Gates Grand Challenges in Global Health advisory board and chairs another Gates-funded organisation. Gates is everywhere.

In a precursor to the 'Covid' script Ferguson backed closing schools 'for prolonged periods' over the swine flu 'pandemic' in 2009 and said it would affect a third of the world population if it continued to spread at the speed he claimed to be happening. His mates at Imperial College said much the same and a news report said: 'One of the authors, the epidemiologist and disease modeller Neil Ferguson, who sits on the World Health Organisation's emergency committee for the outbreak, said the virus had "full pandemic potential".' Professor Liam Donaldson, the Chris Whitty of his day as Chief Medical Officer, said the worst case could see 30 percent of the British people infected by swine flu with 65,000 dying. Ferguson and Donaldson were indeed proved correct when at the end of the year the number of deaths attributed to swine flu was 392. The term 'expert' is rather liberally applied unfortunately, not least to complete idiots. Swine flu 'projections' were great for GlaxoSmithKline (GSK) as millions rolled in for its Pandemrix influenza vaccine which led to brain damage with children most affected. The British government (taxpayers) paid out more than £60 million in compensation after GSK was given immunity from prosecution. Yet another 'Covid' déjà vu. Swine flu was supposed to have broken out in Mexico, but Dr Wolfgang Wodarg, a German doctor, former member of parliament and critic of the 'Covid' hoax, observed 'the spread of swine flu' in Mexico City at the time. He

said: 'What we experienced in Mexico City was a very mild flu which did not kill more than usual – which killed even fewer people than usual.' Hying the fear against all the facts is not unique to 'Covid' and has happened many times before. Ferguson is reported to have over-estimated the projected death toll of bird flu (H5N1) by some three million-fold, but bird flu vaccine makers again made a killing from the scare. This is some of the background to the Neil Ferguson who produced the perfectly-timed computer models in early 2020 predicting that half a million people would die in Britain without draconian lockdown and 2.2 million in the United States. Politicians panicked, people panicked, and lockdowns of alleged short duration were instigated to 'flatten the curve' of cases gleaned from a test not testing for the 'virus'. I said at the time that the public could forget the 'short duration' bit. This was an agenda to destroy the livelihoods of the population and force them into mass control through dependency and there was going to be nothing 'short' about it. American researcher Daniel Horowitz described the consequences of the 'models' spewed out by Gates-funded Ferguson and Imperial College:

What led our government and the governments of many other countries into panic was a single Imperial College of UK study, funded by global warming activists, that predicted 2.2 million deaths if we didn't lock down the country. In addition, the reported 8-9% death rate in Italy scared us into thinking there was some other mutation of this virus that they got, which might have come here.

Together with the fact that we were finally testing and had the ability to actually report new cases, we thought we were headed for a death spiral. But again ... we can't flatten a curve if we don't know when the curve started.

How about it *never* started?

## **Giving them what they want**

An investigation by German news outlet *Welt Am Sonntag* (*World on Sunday*) revealed how in March, 2020, the German government gathered together 'leading scientists from several research institutes and universities' and 'together, they were to produce a [modelling]

paper that would serve as legitimization for further tough political measures'. The Cult agenda was justified by computer modelling not based on evidence or reality; it was specifically constructed to justify the Cult demand for lockdowns all over the world to destroy the independent livelihoods of the global population. All these modellers and everyone responsible for the 'Covid' hoax have a date with a trial like those in Nuremberg after World War Two when Nazis faced the consequences of their war crimes. These corrupt-beyond-belief 'modellers' wrote the paper according to government instructions and it said that that if lockdown measures were lifted then up to one million Germans would die from 'Covid-19' adding that some would die 'agonizingly at home, gasping for breath' unable to be treated by hospitals that couldn't cope. All lies. No matter – it gave the Cult all that it wanted. What did long-time government 'modeller' Neil Ferguson say? If the UK and the United States didn't lockdown half a million would die in Britain and 2.2 million Americans. Anyone see a theme here? 'Modellers' are such a crucial part of the lockdown strategy that we should look into their background and follow the money. Researcher Rosemary Frei produced an excellent article headlined 'The Modelling-paper Mafiosi'. She highlights a guy called John Edmunds, a British epidemiologist, and professor in the Faculty of Epidemiology and Population Health at the London School of Hygiene & Tropical Medicine. He studied at Imperial College. Edmunds is a member of government 'Covid' advisory bodies which have been dictating policy, the New and Emerging Respiratory Virus Threats Advisory Group (NERVTAG) and the Scientific Advisory Group for Emergencies (SAGE).

Ferguson, another member of NERVTAG and SAGE, led the way with the original 'virus' and Edmunds has followed in the 'variant' stage and especially the so-called UK or Kent variant known as the 'Variant of Concern' (VOC) B.1.1.7. He said in a co-written report for the Centre for Mathematical modelling of Infectious Diseases at the London School of Hygiene and Tropical Medicine, with input from the Centre's 'Covid-19' Working Group, that there was 'a realistic



possibility that VOC B.1.1.7 is associated with an increased risk of death compared to non-VOC viruses'. Fear, fear, fear, get the vaccine, fear, fear, fear, get the vaccine. Rosemary Frei reveals that almost all the paper's authors and members of the modelling centre's 'Covid-19' Working Group receive funding from the Bill and Melinda Gates Foundation and/or the associated Gates-funded Wellcome Trust. The paper was published by e-journal *Medrx* *xiv* which only publishes papers not peer-reviewed and the journal was established by an organisation headed by Facebook's Mark Zuckerberg and his missus. What a small world it is. Frei discovered that Edmunds is on the Scientific Advisory Board of the Coalition for Epidemic Preparedness Innovations (CEPI) which was established by the Bill and Melinda Gates Foundation, Klaus Schwab's Davos World Economic Forum and Big Pharma giant Wellcome. CEPI was 'launched in Davos [in 2017] to develop vaccines to stop future epidemics', according to its website. 'Our mission is to accelerate the development of vaccines against emerging infectious diseases and enable equitable access to these vaccines for people during outbreaks.' What kind people they are. Rosemary Frei reveals that Public Health England (PHE) director Susan Hopkins is an author of her organisation's non-peer-reviewed reports on 'new variants'. Hopkins is a professor of infectious diseases at London's Imperial College which is gifted tens of millions of dollars a year by the Bill and Melinda Gates Foundation. Gates-funded modelling disaster Neil Ferguson also co-authors Public Health England reports and he spoke in December, 2020, about the potential danger of the B.1.1.7. 'UK variant' promoted by Gates-funded modeller John Edmunds. When I come to the 'Covid vaccines' the 'new variants' will be shown for what they are – bollocks.

## **Connections, connections**

All these people and modellers are lockdown-obsessed or, put another way, they demand what the Cult demands. Edmunds said in January, 2021, that to ease lockdowns too soon would be a disaster and they had to 'vaccinate much, much, much more widely than the

elderly'. Rosemary Frei highlights that Edmunds is married to Jeanne Pimenta who is described in a LinkedIn profile as director of epidemiology at GlaxoSmithKline (GSK) and she held shares in the company. Patrick Vallance, co-chair of SAGE and the government's Chief Scientific Adviser, is a former executive of GSK and has a deferred bonus of shares in the company worth £600,000. GSK has serious business connections with Bill Gates and is collaborating with mRNA-'vaccine' company CureVac to make 'vaccines' for the new variants that Edmunds is talking about. GSK is planning a 'Covid vaccine' with drug giant Sanofi. Puppets Prime Minister Boris Johnson announced in the spring of 2021 that up to 60 million vaccine doses were to be made at the GSK facility at Barnard Castle in the English North East. Barnard Castle, with a population of just 6,000, was famously visited in breach of lockdown rules in April, 2020, by Johnson aide Dominic Cummings who said that he drove there 'to test his eyesight' before driving back to London. Cummings would be better advised to test his integrity – not that it would take long. The GSK facility had nothing to do with his visit then although I'm sure Patrick Vallance would have been happy to arrange an introduction and some tea and biscuits. Ruthless psychopath Gates has made yet another fortune from vaccines in collaboration with Big Pharma companies and gushes at the phenomenal profits to be made from vaccines – more than a 20-to-1 return as he told one interviewer. Gates also tweeted in December, 2019, with the foreknowledge of what was coming: 'What's next for our foundation? I'm particularly excited about what the next year could mean for one of the best buys in global health: vaccines.'

Modeller John Edmunds is a big promoter of vaccines as all these people appear to be. He's the dean of the London School of Hygiene & Tropical Medicine's Faculty of Epidemiology and Population Health which is primarily funded by the Bill and Melinda Gates Foundation and the Gates-established and funded GAVI vaccine alliance which is the Gates vehicle to vaccinate the world. The organisation Doctors Without Borders has described GAVI as being 'aimed more at supporting drug-industry desires to promote new

products than at finding the most efficient and sustainable means for fighting the diseases of poverty'. But then that's why the psychopath Gates created it. John Edmunds said in a video that the London School of Hygiene & Tropical Medicine is involved in every aspect of vaccine development including large-scale clinical trials. He contends that mathematical modelling can show that vaccines protect individuals and society. That's on the basis of shit in and shit out, I take it. Edmunds serves on the UK Vaccine Network as does Ferguson and the government's foremost 'Covid' adviser, the grim-faced, dark-eyed Chris Whitty. The Vaccine Network says it works 'to support the government to identify and shortlist targeted investment opportunities for the most promising vaccines and vaccine technologies that will help combat infectious diseases with epidemic potential, and to address structural issues related to the UK's broader vaccine infrastructure'. Ferguson is acting Director of the Imperial College Vaccine Impact Modelling Consortium which has funding from the Bill and Melina Gates Foundation and the Gates-created GAVI 'vaccine alliance'. Anyone wonder why these characters see vaccines as the answer to every problem? Ferguson is wildly enthusiastic in his support for GAVI's campaign to vaccinate children en masse in poor countries. You would expect someone like Gates who has constantly talked about the need to reduce the population to want to fund vaccines to keep more people alive. I'm sure that's why he does it. The John Edmunds London School of Hygiene & Tropical Medicine (LSHTM) has a Vaccines Manufacturing Innovation Centre which develops, tests and commercialises vaccines. Rosemary Frei writes:

The vaccines centre also performs affiliated activities like combating 'vaccine hesitancy'. The latter includes the Vaccine Confidence Project. The project's stated purpose is, among other things, 'to provide analysis and guidance for early response and engagement with the public to ensure sustained confidence in vaccines and immunisation'. The Vaccine Confidence Project's director is LSHTM professor Heidi Larson. For more than a decade she's been researching how to combat vaccine hesitancy.

How the bloody hell can blokes like John Edmunds and Neil Ferguson with those connections and financial ties model 'virus' case

and death projections for the government and especially in a way that gives their paymasters like Gates exactly what they want? It's insane, but this is what you find throughout the world.

### **'Covid' is not dangerous, oops, wait, yes it is**

Only days before Ferguson's nightmare scenario made Jackboot Johnson take Britain into a China-style lockdown to save us from a deadly 'virus' the UK government website gov.uk was reporting something very different to Ferguson on a page of official government guidance for 'high consequence infectious diseases (HCID)'. It said this about 'Covid-19':

*As of 19 March 2020, COVID-19 is no longer considered to be a high consequence infectious diseases (HCID) in the UK [my emphasis].* The 4 nations public health HCID group made an interim recommendation in January 2020 to classify COVID-19 as an HCID. This was based on consideration of the UK HCID criteria about the virus and the disease with information available during the early stages of the outbreak.

Now that more is known about COVID-19, the public health bodies in the UK have reviewed the most up to date information about COVID-19 against the UK HCID criteria. They have determined that several features have now changed; in particular, more information is available about mortality rates (low overall), and there is now greater clinical awareness and a specific and sensitive laboratory test, the availability of which continues to increase. The Advisory Committee on Dangerous Pathogens (ACDP) is also of the opinion that COVID-19 should no longer be classified as an HCID.

Soon after the government had been exposed for downgrading the risk they upgraded it again and everyone was back to singing from the same Cult hymn book. Ferguson and his fellow Gates clones indicated that lockdowns and restrictions would have to continue until a Gates-funded vaccine was developed. Gates said the same because Ferguson and his like were repeating the Gates script which is the Cult script. 'Flatten the curve' became an ongoing nightmare of continuing lockdowns with periods in between of severe restrictions in pursuit of destroying independent incomes and had nothing to do with protecting health about which the Cult gives not a shit. Why wouldn't Ferguson be pushing a vaccine 'solution' when he's owned by vaccine-obsessive Gates who makes a fortune from them and

when Ferguson heads the Vaccine Impact Modelling Consortium at Imperial College funded by the Gates Foundation and GAVI, the 'vaccine alliance', created by Gates as his personal vaccine promotion operation? To compound the human catastrophe that Ferguson's 'models' did so much to create he was later exposed for breaking his own lockdown rules by having sexual liaisons with his married girlfriend Antonia Staats at his home while she was living at another location with her husband and children. Staats was a 'climate' activist and senior campaigner at the Soros-funded Avaaz which I wouldn't trust to tell me that grass is green. Ferguson had to resign as a government advisor over this hypocrisy in May, 2020, but after a period of quiet he was back being quoted by the ridiculous media on the need for more lockdowns and a vaccine rollout. Other government-advising 'scientists' from Imperial College held the fort in his absence and said lockdown could be indefinite until a vaccine was found. The Cult script was being sung by the payrolled choir. I said there was no intention of going back to 'normal' when the 'vaccine' came because the 'vaccine' is part of a very different agenda that I will discuss in Human 2.0. Why would the Cult want to let the world go back to normal when destroying that normal forever was the whole point of what was happening? House arrest, closing businesses and schools through lockdown, (un)social distancing and masks all followed the Ferguson fantasy models. Again as I predicted (these people are so predictable) when the 'vaccine' arrived we were told that house arrest, lockdown, (un)social distancing and masks would still have to continue. I will deal with the masks in the next chapter because they are of fundamental importance.

## **Where's the 'pandemic'?**

Any mildly in-depth assessment of the figures revealed what was really going on. Cult-funded and controlled organisations still have genuine people working within them such is the number involved. So it is with Genevieve Briand, assistant program director of the Applied Economics master's degree program at Johns Hopkins

University. She analysed the impact that 'Covid-19' had on deaths from *all* causes in the United States using official data from the CDC for the period from early February to early September, 2020. She found that allegedly 'Covid' *related*-deaths exceeded those from heart disease which she found strange with heart disease always the biggest cause of fatalities. Her research became even more significant when she noted the sudden decline in 2020 of *all* non-'Covid' deaths: 'This trend is completely contrary to the pattern observed in all previous years ... the total decrease in deaths by other causes almost exactly equals the increase in deaths by Covid-19.' This was such a game, set and match in terms of what was happening that Johns Hopkins University deleted the article on the grounds that it 'was being used to support false and dangerous inaccuracies about the impact of the pandemic'. No – because it exposed the scam from official CDC figures and this was confirmed when those figures were published in January, 2021. Here we can see the effect of people dying from heart attacks, cancer, road accidents and gunshot wounds – *anything* – having 'Covid-19' on the death certificate along with those diagnosed from 'symptoms' who had even not tested positive with a test not testing for the 'virus'. I am not kidding with the gunshot wounds, by the way. Brenda Bock, coroner in Grand County, Colorado, revealed that two gunshot victims tested positive for the 'virus' within the previous 30 days and were therefore classified as 'Covid deaths'. Bock said: 'These two people had tested positive for Covid, but that's not what killed them. A gunshot wound is what killed them.' She said she had not even finished her investigation when the state listed the gunshot victims as deaths due to the 'virus'. The death and case figures for 'Covid-19' are an absolute joke and yet they are repeated like parrots by the media, politicians and alleged medical 'experts'. The official Cult narrative is the only show in town.

Genevieve Briand found that deaths from all causes were not exceptional in 2020 compared with previous years and a Spanish magazine published figures that said the same about Spain which was a 'Covid' propaganda hotspot at one point. *Discovery Salud*, a

health and medicine magazine, quoted government figures which showed how 17,000 *fewer* people died in Spain in 2020 than in 2019 and more than 26,000 fewer than in 2018. The age-standardised mortality rate for England and Wales when age distribution is taken into account was significantly lower in 2020 than the 1970s, 80s and 90s, and was only the ninth highest since 2000. Where is the 'pandemic'?

Post mortems and autopsies virtually disappeared for 'Covid' deaths amid claims that 'virus-infected' bodily fluids posed a risk to those carrying out the autopsy. This was rejected by renowned German pathologist and forensic doctor Klaus Püschel who said that he and his staff had by then done 150 autopsies on 'Covid' patients with no problems at all. He said they were needed to know why some 'Covid' patients suffered blood clots and not severe respiratory infections. The 'virus' is, after all, called SARS or 'severe acute respiratory syndrome'. I highlighted in the spring of 2020 this phenomenon and quoted New York intensive care doctor Cameron Kyle-Sidell who posted a soon deleted YouTube video to say that they had been told to prepare to treat an infectious disease called 'Covid-19', but that was not what they were dealing with. Instead he likened the lung condition of the most severely ill patients to what you would expect with cabin depressurisation in a plane at 30,000 feet or someone dropped on the top of Everest without oxygen or acclimatisation. I have never said this is not happening to a small minority of alleged 'Covid' patients – I am saying this is not caused by a phantom 'contagious virus'. Indeed Kyle-Sidell said that 'Covid-19' was not the disease they were told was coming their way. 'We are operating under a medical paradigm that is untrue,' he said, and he believed they were treating the wrong disease: 'These people are being slowly starved of oxygen.' Patients would take off their oxygen masks in a state of fear and stress and while they were blue in the face on the brink of death. They did not look like patients dying of pneumonia. You can see why they don't want autopsies when their virus doesn't exist and there is another condition in some people that they don't wish to be uncovered. I should add here that

the 5G system of millimetre waves was being rapidly introduced around the world in 2020 and even more so now as they fire 5G at the Earth from satellites. At 60 gigahertz within the 5G range that frequency interacts with the oxygen molecule and stops people breathing in sufficient oxygen to be absorbed into the bloodstream. They are installing 5G in schools and hospitals. The world is not mad or anything. 5G can cause major changes to the lungs and blood as I detail in *The Answer* and these consequences are labelled 'Covid-19', the alleged symptoms of which can be caused by 5G and other electromagnetic frequencies as cells respond to radiation poisoning.

### **The 'Covid death' scam**

Dr Scott Jensen, a Minnesota state senator and medical doctor, exposed 'Covid' Medicare payment incentives to hospitals and death certificate manipulation. He said he was sent a seven-page document by the US Department of Health 'coaching' him on how to fill out death certificates which had never happened before. The document said that he didn't need to have a laboratory test for 'Covid-19' to put that on the death certificate and that shocked him when death certificates are supposed to be about facts. Jensen described how doctors had been 'encouraged, if not pressured' to make a diagnosis of 'Covid-19' if they thought it was probable or '*presumed*'. No positive test was necessary – not that this would have mattered anyway. He said doctors were told to diagnose 'Covid' by symptoms when these were the same as colds, allergies, other respiratory problems, and certainly with influenza which 'disappeared' in the 'Covid' era. A common sniffle was enough to get the dreaded verdict. Ontario authorities decreed that a single care home resident with *one* symptom from a long list must lead to the isolation of the entire home. Other courageous doctors like Jensen made the same point about death figure manipulation and how deaths by other causes were falling while 'Covid-19 deaths' were rising at the same rate due to re-diagnosis. Their videos rarely survive long on YouTube with its Cult-supporting algorithms courtesy of CEO Susan Wojcicki and her bosses at Google. Figure-tampering was so glaring



and ubiquitous that even officials were letting it slip or outright saying it. UK chief scientific adviser Patrick Vallance said on one occasion that 'Covid' on the death certificate doesn't mean 'Covid' was the cause of death (so why the hell is it there?) and we had the rare sight of a BBC reporter telling the truth when she said: 'Someone could be successfully treated for Covid, in say April, discharged, and then in June, get run over by a bus and die ... That person would still be counted as a Covid death in England.' Yet the BBC and the rest of the world media went on repeating the case and death figures as if they were real. Illinois Public Health Director Dr Ngozi Ezike revealed the deceit while her bosses must have been clenching their buttocks:

If you were in a hospice and given a few weeks to live and you were then found to have Covid that would be counted as a Covid death. [There might be] a clear alternate cause, but it is still listed as a Covid death. So everyone listed as a Covid death doesn't mean that was the cause of the death, but that they had Covid at the time of death.

Yes, a 'Covid virus' never shown to exist and tested for with a test not testing for the 'virus'. In the first period of the pandemic hoax through the spring of 2020 the process began of designating almost everything a 'Covid' death and this has continued ever since. I sat in a restaurant one night listening to a loud conversation on the next table where a family was discussing in bewilderment how a relative who had no symptoms of 'Covid', and had died of a long-term problem, could have been diagnosed a death by the 'virus'. I could understand their bewilderment. If they read this book they will know why this medical fraud has been perpetrated the world over.

### **Some media truth shock**

The media ignored the evidence of death certificate fraud until eventually one columnist did speak out when she saw it first-hand. Bel Mooney is a long-time national newspaper journalist in Britain currently working for the *Daily Mail*. Her article on February 19th, 2021, carried this headline: 'My dad Ted passed three Covid tests

and died of a chronic illness yet he's officially one of Britain's 120,000 victims of the virus and is far from alone ... so how many more are there?' She told how her 99-year-old father was in a care home with a long-standing chronic obstructive pulmonary disease and vascular dementia. Maybe, but he was still aware enough to tell her from the start that there was no 'virus' and he refused the 'vaccine' for that reason. His death was not unexpected given his chronic health problems and Mooney said she was shocked to find that 'Covid-19' was declared the cause of death on his death certificate. She said this was a 'bizarre and unacceptable untruth' for a man with long-time health problems who had tested negative twice at the home for the 'virus'. I was also shocked by this story although not by what she said. I had been highlighting the death certificate manipulation for ten months. It was the confirmation that a professional full-time journalist only realised this was going on when it affected her directly and neither did she know that whether her dad tested positive or negative was irrelevant with the test not testing for the 'virus'. Where had she been? She said she did not believe in 'conspiracy theories' without knowing I'm sure that this and 'conspiracy theorists' were terms put into widespread circulation by the CIA in the 1960s to discredit those who did not accept the ridiculous official story of the Kennedy assassination. A blanket statement of 'I don't believe in conspiracy theories' is always bizarre. The dictionary definition of the term alone means the world is drowning in conspiracies. What she said was even more daft when her dad had just been affected by the 'Covid' conspiracy. Why else does she think that 'Covid-19' was going on the death certificates of people who died of something else?

To be fair once she saw from personal experience what was happening she didn't mince words. Mooney was called by the care home on the morning of February 9th to be told her father had died in his sleep. When she asked for the official cause of death what came back was 'Covid-19'. Mooney challenged this and was told there had been deaths from Covid on the dementia floor (confirmed by a test not testing for the 'virus') so they considered it 'reasonable

to assume'. 'But doctor,' Mooney rightly protested, 'an assumption isn't a diagnosis.' She said she didn't blame the perfectly decent and sympathetic doctor – 'he was just doing his job'. Sorry, but that's *bullshit*. He wasn't doing his job at all. He was putting a false cause of death on the death certificate and that is a criminal offence for which he should be brought to account and the same with the millions of doctors worldwide who have done the same. They were not doing their job they were following orders and that must not wash at new Nuremberg trials any more than it did at the first ones. Mooney's doctor was 'assuming' (presuming) as he was told to, but 'just following orders' makes no difference to his actions. A doctor's job is to serve the patient and the truth, not follow orders, but that's what they have done all over the world and played a central part in making the 'Covid' hoax possible with all its catastrophic consequences for humanity. Shame on them and they must answer for their actions. Mooney said her disquiet worsened when she registered her father's death by telephone and was told by the registrar there had been very many other cases like hers where 'the deceased' had not tested positive for 'Covid' yet it was recorded as the cause of death. The test may not matter, but those involved at their level *think* it matters and it shows a callous disregard for accurate diagnosis. The pressure to do this is coming from the top of the national 'health' pyramids which in turn obey the World Health Organization which obeys Gates and the Cult. Mooney said the registrar agreed that this must distort the national figures adding that 'the strangest thing is that every winter we record countless deaths from flu, and this winter there have been none. Not one!' She asked if the registrar thought deaths from flu were being misdiagnosed and lumped together with 'Covid' deaths. The answer was a 'puzzled yes'. Mooney said that the funeral director said the same about 'Covid' deaths which had nothing to do with 'Covid'. They had lost count of the number of families upset by this and other funeral companies in different countries have had the same experience. Mooney wrote:

The nightly shroud-waving and shocking close-ups of pain imposed on us by the TV news bewildered and terrified the population into eager compliance with lockdowns. We were invited to 'save the NHS' and to grieve for strangers – the real-life loved ones behind those shocking death counts. Why would the public imagine what I now fear, namely that the way Covid-19 death statistics are compiled might make the numbers seem greater than they are?

Oh, just a little bit – like 100 percent.

## **Do the maths**

Mooney asked why a country would wish to skew its mortality figures by wrongly certifying deaths? What had been going on? Well, if you don't believe in conspiracies you will never find the answer which is that *it's a conspiracy*. She did, however, describe what she had discovered as a 'national scandal'. In reality it's a global scandal and happening everywhere. Pillars of this conspiracy were all put into place before the button was pressed with the Drosten PCR protocol and high amplifications to produce the cases and death certificate changes to secure illusory 'Covid' deaths. Mooney notes that normally two doctors were needed to certify a death, with one having to know the patient, and how the rules were changed in the spring of 2020 to allow one doctor to do this. In the same period 'Covid deaths' were decreed to be all cases where Covid-19 was put on the death certificate even without a positive test or any symptoms. Mooney asked: 'How many of the 30,851 (as of January 15) care home resident deaths with Covid-19 on the certificate (32.4 per cent of all deaths so far) were based on an assumption, like that of my father? And what has that done to our national psyche?' All of them is the answer to the first question and it has devastated and dismantled the national psyche, actually the global psyche, on a colossal scale. In the UK case and death data is compiled by organisations like Public Health England (PHE) and the Office for National Statistics (ONS). Mooney highlights the insane policy of counting a death from any cause as 'Covid-19' if this happens within 28 days of a positive test (with a test not testing for the 'virus') and she points out that ONS statistics reflect deaths 'involving Covid' 'or due to Covid' which meant in practice any

death where 'Covid-19' was mentioned on the death certificate. She described the consequences of this fraud:

Most people will accept the narrative they are fed, so panicky governments here and in Europe witnessed the harsh measures enacted in totalitarian China and jumped into lockdown. Headlines about Covid deaths tolled like the knell that would bring doomsday to us all. Fear stalked our empty streets. Politicians parroted the frankly ridiculous aim of 'zero Covid' and shut down the economy, while most British people agreed that lockdown was essential and (astonishingly to me, as a patriotic Brit) even wanted more restrictions.

For what? Lies on death certificates? Never mind the grim toll of lives ruined, suicides, schools closed, rising inequality, depression, cancelled hospital treatments, cancer patients in a torture of waiting, poverty, economic devastation, loneliness, families kept apart, and so on. How many lives have been lost as a direct result of lockdown?

She said that we could join in a national chorus of shock and horror at reaching the 120,000 death toll which was surely certain to have been totally skewed all along, but what about the human cost of lockdown justified by these 'death figures'? *The British Medical Journal* had reported a 1,493 percent increase in cases of children taken to Great Ormond Street Hospital with abusive head injuries alone and then there was the effect on families:

Perhaps the most shocking thing about all this is that families have been kept apart – and obeyed the most irrational, changing rules at the whim of government – because they believed in the statistics. They succumbed to fear, which his generation rejected in that war fought for freedom. Dad (God rest his soul) would be angry. And so am I.

Another theme to watch is that in the winter months when there are more deaths from all causes they focus on 'Covid' deaths and in the summer when the British Lung Foundation says respiratory disease plummets by 80 percent they rage on about 'cases'. Either way fascism on population is always the answer.

## **Nazi eugenics in the 21st century**

Elderly people in care homes have been isolated from their families month after lonely month with no contact with relatives and grandchildren who were banned from seeing them. We were told

that lockdown fascism was to 'protect the vulnerable' like elderly people. At the same time Do Not Resuscitate (DNR) orders were placed on their medical files so that if they needed resuscitation it wasn't done and 'Covid-19' went on their death certificates. Old people were not being 'protected' they were being culled – murdered in truth. DNR orders were being decreed for disabled and young people with learning difficulties or psychological problems. The UK Care Quality Commission, a non-departmental body of the Department of Health and Social Care, found that 34 percent of those working in health and social care were pressured into placing 'do not attempt cardiopulmonary resuscitation' orders on 'Covid' patients who suffered from disabilities and learning difficulties without involving the patient or their families in the decision. UK judges ruled that an elderly woman with dementia should have the DNA-manipulating 'Covid vaccine' against her son's wishes and that a man with severe learning difficulties should have the job despite his family's objections. Never mind that many had already died. The judiciary always supports doctors and government in fascist dictatorships. They wouldn't dare do otherwise. A horrific video was posted showing fascist officers from Los Angeles police forcibly giving the 'Covid' shot to women with special needs who were screaming that they didn't want it. The same fascists are seen giving the jab to a sleeping elderly woman in a care home. This is straight out of the Nazi playbook. Hitler's Nazis committed mass murder of the mentally ill and physically disabled throughout Germany and occupied territories in the programme that became known as Aktion T4, or just T4. Sabbatian-controlled Hitler and his grotesque crazies set out to kill those they considered useless and unnecessary. The Reich Committee for the Scientific Registering of Hereditary and Congenital Illnesses registered the births of babies identified by physicians to have 'defects'. By 1941 alone more than 5,000 children were murdered by the state and it is estimated that in total the number of innocent people killed in Aktion T4 was between 275,000 and 300,000. Parents were told their children had been sent away for 'special treatment' never to return. It is rather pathetic to see claims about plans for new extermination camps being dismissed today

when the same force behind current events did precisely that 80 years ago. Margaret Sanger was a Cult operative who used 'birth control' to sanitise her programme of eugenics. Organisations she founded became what is now Planned Parenthood. Sanger proposed that 'the whole dysgenic population would have its choice of segregation or sterilization'. These included epileptics, 'feeble-minded', and prostitutes. Sanger opposed charity because it perpetuated 'human waste'. She reveals the Cult mentality and if anyone thinks that extermination camps are a 'conspiracy theory' their naivety is touching if breathtakingly stupid.

If you don't believe that doctors can act with callous disregard for their patients it is worth considering that doctors and medical staff agreed to put government-decreed DNR orders on medical files and do nothing when resuscitation is called for. I don't know what you call such people in your house. In mine they are Nazis from the Josef Mengele School of Medicine. Phenomenal numbers of old people have died worldwide from the effects of lockdown, depression, lack of treatment, the 'vaccine' (more later) and losing the will to live. A common response at the start of the manufactured pandemic was to remove old people from hospital beds and transfer them to nursing homes. The decision would result in a mass cull of elderly people in those homes through lack of treatment – *not* 'Covid'. Care home whistleblowers have told how once the 'Covid' era began doctors would not come to their homes to treat patients and they were begging for drugs like antibiotics that often never came. The most infamous example was ordered by New York governor Andrew Cuomo, brother of a moronic CNN host, who amazingly was given an Emmy Award for his handling of the 'Covid crisis' by the ridiculous Wokers that hand them out. Just how ridiculous could be seen in February, 2021, when a Department of Justice and FBI investigation began into how thousands of old people in New York died in nursing homes after being discharged from hospital to make way for 'Covid' patients on Cuomo's say-so – and how he and his staff covered up these facts. This couldn't have happened to a nicer psychopath. Even then there was a 'Covid' spin. Reports said that

thousands of old people who tested positive for 'Covid' in hospital were transferred to nursing homes to both die of 'Covid' and transmit it to others. No – they were in hospital because they were ill and the fact that they tested positive with a test not testing for the 'virus' is irrelevant. They were ill often with respiratory diseases ubiquitous in old people near the end of their lives. Their transfer out of hospital meant that their treatment stopped and many would go on to die.

### **They're old. Who gives a damn?**

I have exposed in the books for decades the Cult plan to cull the world's old people and even to introduce at some point what they call a 'demise pill' which at a certain age everyone would take and be out of here by law. In March, 2021, Spain legalised euthanasia and assisted suicide following the Netherlands, Belgium, Luxembourg and Canada on the Tiptoe to the demise pill. Treatment of old people by many 'care' homes has been a disgrace in the 'Covid' era. There are many, many, caring staff – I know some. There have, however, been legions of stories about callous treatment of old people and their families. Police were called when families came to take their loved ones home in the light of isolation that was killing them. They became prisoners of the state. Care home residents in insane, fascist Ontario, Canada, were not allowed to leave their *room* once the 'Covid' hoax began. UK staff have even wheeled elderly people away from windows where family members were talking with them. Oriana Criscuolo from Stockport in the English North West dropped off some things for her 80-year-old father who has Parkinson's disease and dementia and she wanted to wave to him through a ground-floor window. She was told that was 'illegal'. When she went anyway they closed the curtains in the middle of the day. Oriana said:

It's just unbelievable. I cannot understand how care home staff – people who are being paid to care – have become so uncaring. Their behaviour is inhumane and cruel. It's beyond belief.



She was right and this was not a one-off. What a way to end your life in such loveless circumstances. UK registered nurse Nicky Millen, a proper old school nurse for 40 years, said that when she started her career care was based on dignity, choice, compassion and empathy. Now she said 'the things that are important to me have gone out of the window.' She was appalled that people were dying without their loved ones and saying goodbye on iPads. Nicky described how a distressed 89-year-old lady stroked her face and asked her 'how many paracetamol would it take to finish me off'. Life was no longer worth living while not seeing her family. Nicky said she was humiliated in front of the ward staff and patients for letting the lady stroke her face and giving her a cuddle. Such is the dehumanisation that the 'Covid' hoax has brought to the surface. Nicky worked in care homes where patients told her they were being held prisoner. 'I want to live until I die', one said to her. 'I had a lady in tears because she hadn't seen her great-grandson.' Nicky was compassionate old school meeting psychopathic New Normal. She also said she had worked on a 'Covid' ward with no 'Covid' patients. Jewish writer Shai Held wrote an article in March, 2020, which was headlined 'The Staggering, Heartless Cruelty Toward the Elderly'. What he described was happening from the earliest days of lockdown. He said 'the elderly' were considered a group and not unique individuals (the way of the Woke). Shai Held said:

Notice how the all-too-familiar rhetoric of dehumanization works: 'The elderly' are bunched together as a faceless mass, all of them considered culprits and thus effectively deserving of the suffering the pandemic will inflict upon them. Lost entirely is the fact that the elderly are individual human beings, each with a distinctive face and voice, each with hopes and dreams, memories and regrets, friendships and marriages, loves lost and loves sustained.

'The elderly' have become another dehumanised group for which anything goes and for many that has resulted in cold disregard for their rights and their life. The distinctive face that Held talks about is designed to be deleted by masks until everyone is part of a faceless mass.

## **'War-zone' hospitals myth**

Again and again medical professionals have told me what was really going on and how hospitals 'overrun like war zones' according to the media were virtually empty. The mantra from medical whistleblowers was please don't use my name or my career is over. Citizen journalists around the world sneaked into hospitals to film evidence exposing the 'war-zone' lie. They really *were* largely empty with closed wards and operating theatres. I met a hospital worker in my town on the Isle of Wight during the first lockdown in 2020 who said the only island hospital had never been so quiet. Lockdown was justified by the psychopaths to stop hospitals being overrun. At the same time that the island hospital was near-empty the military arrived here to provide *extra beds*. It was all propaganda to ramp up the fear to ensure compliance with fascism as were never-used temporary hospitals with thousands of beds known as Nightingales and never-used make-shift mortuaries opened by the criminal UK government. A man who helped to install those extra island beds attributed to the army said they were never used and the hospital was empty. Doctors and nurses 'stood around talking or on their phones, wandering down to us to see what we were doing'. There were no masks or social distancing. He accused the useless local island paper, the *County Press*, of 'pumping the fear as if our hospital was overrun and we only have one so it should have been'. He described ambulances parked up with crews outside in deck chairs. When his brother called an ambulance he was told there was a two-hour backlog which he called 'bullshit'. An old lady on the island fell 'and was in a bad way', but a caller who rang for an ambulance was told the situation wasn't urgent enough. Ambulance stations were working under capacity while people would hear ambulances with sirens blaring driving through the streets. When those living near the stations realised what was going on they would follow them as they left, circulated around an urban area with the sirens going, and then came back without stopping. All this was to increase levels of fear and the same goes for the 'ventilator shortage crisis' that cost tens of millions for hastily produced ventilators never to be used.

Ambulance crews that agreed to be exploited in this way for fear propaganda might find themselves a mirror. I wish them well with that. Empty hospitals were the obvious consequence of treatment and diagnoses of non-'Covid' conditions cancelled and those involved handed a death sentence. People have been dying at home from undiagnosed and untreated cancer, heart disease and other life-threatening conditions to allow empty hospitals to deal with a 'pandemic' that wasn't happening.

## **Death of the innocent**

'War-zones' have been laying off nursing staff, even doctors where they can. There was no work for them. Lockdown was justified by saving lives and protecting the vulnerable they were actually killing with DNR orders and preventing empty hospitals being 'overrun'. In Britain the mantra of stay at home to 'save the NHS' was everywhere and across the world the same story was being sold when it was all lies. Two California doctors, Dan Erickson and Artin Massihi at Accelerated Urgent Care in Bakersfield, held a news conference in April, 2020, to say that intensive care units in California were 'empty, essentially', with hospitals shutting floors, not treating patients and laying off doctors. The California health system was working at minimum capacity 'getting rid of doctors because we just don't have the volume'. They said that people with conditions such as heart disease and cancer were not coming to hospital out of fear of 'Covid-19'. Their video was deleted by Susan Wojcicki's Cult-owned YouTube after reaching five million views. Florida governor Ron Desantis, who rejected the severe lockdowns of other states and is being targeted for doing so, said that in March, 2020, every US governor was given models claiming they would run out of hospital beds in days. That was never going to happen and the 'modellers' knew it. Deceit can be found at every level of the system. Urgent children's operations were cancelled including fracture repairs and biopsies to spot cancer. Eric Nicholls, a consultant paediatrician, said 'this is obviously concerning and we need to return to normal operating and to increase capacity as soon as possible'. Psychopaths

in power were rather less concerned *because* they are psychopaths. Deletion of urgent care and diagnosis has been happening all over the world and how many kids and others have died as a result of the actions of these cold and heartless lunatics dictating 'health' policy? The number must be stratospheric. Richard Sullivan, professor of cancer and global health at King's College London, said people feared 'Covid' more than cancer such was the campaign of fear. 'Years of lost life will be quite dramatic', Sullivan said, with 'a huge amount of avoidable mortality'. Sarah Woolnough, executive director for policy at Cancer Research UK, said there had been a 75 percent drop in urgent referrals to hospitals by family doctors of people with suspected cancer. Sullivan said that 'a lot of services have had to scale back – we've seen a dramatic decrease in the amount of elective cancer surgery'. Lockdown deaths worldwide has been absolutely fantastic with the *New York Post* reporting how data confirmed that 'lockdowns end more lives than they save':

There was a sharp decline in visits to emergency rooms and an increase in fatal heart attacks because patients didn't receive prompt treatment. Many fewer people were screened for cancer. Social isolation contributed to excess deaths from dementia and Alzheimer's.

Researchers predicted that the social and economic upheaval would lead to tens of thousands of "deaths of despair" from drug overdoses, alcoholism and suicide. As unemployment surged and mental-health and substance-abuse treatment programs were interrupted, the reported levels of anxiety, depression and suicidal thoughts increased dramatically, as did alcohol sales and fatal drug overdoses.

This has been happening while nurses and other staff had so much time on their hands in the 'war-zones' that Tic-Tok dancing videos began appearing across the Internet with medical staff dancing around in empty wards and corridors as people died at home from causes that would normally have been treated in hospital.

## **Mentions in dispatches**

One brave and truth-committed whistleblower was Louise Hampton, a call handler with the UK NHS who made a viral Internet video saying she had done 'fuck all' during the 'pandemic'

which was 'a load of bollocks'. She said that 'Covid-19' was rebranded flu and of course she lost her job. This is what happens in the medical and endless other professions now when you tell the truth. Louise filmed inside 'war-zone' accident and emergency departments to show they were empty and I mean *empty* as in no one there. The mainstream media could have done the same and blown the gaff on the whole conspiracy. They haven't to their eternal shame. Not that most 'journalists' seem capable of manifesting shame as with the psychopaths they slavishly repeat without question. The relative few who were admitted with serious health problems were left to die alone with no loved ones allowed to see them because of 'Covid' rules and they included kids dying without the comfort of mum and dad at their bedside while the evil behind this couldn't give a damn. It was all good fun to them. A Scottish NHS staff nurse publicly quit in the spring of 2021 saying: 'I can no longer be part of the lies and the corruption by the government.' She said hospitals 'aren't full, the beds aren't full, beds have been shut, wards have been shut'. Hospitals were never busy throughout 'Covid'. The staff nurse said that Nicola Sturgeon, tragically the leader of the Scottish government, was on television saying save the hospitals and the NHS – 'but the beds are empty' and 'we've not seen flu, we always see flu every year'. She wrote to government and spoke with her union Unison (the unions are Cult-compromised and *useless*, but nothing changed. Many of her colleagues were scared of losing their jobs if they spoke out as they wanted to. She said nursing staff were being affected by wearing masks all day and 'my head is splitting every shift from wearing a mask'. The NHS is part of the fascist tyranny and must be dismantled so we can start again with human beings in charge. (Ironically, hospitals were reported to be busier again when official 'Covid' cases *fell* in spring/summer of 2021 and many other conditions required treatment at the same time as *the fake vaccine rollout*.)

I will cover the 'Covid vaccine' scam in detail later, but it is another indicator of the sickening disregard for human life that I am highlighting here. The DNA-manipulating concoctions do not fulfil

the definition of a 'vaccine', have never been used on humans before and were given only emergency approval because trials were not completed and they continued using the unknowing public. The result was what a NHS senior nurse with responsibility for 'vaccine' procedure said was 'genocide'. She said the 'vaccines' were not 'vaccines'. They had not been shown to be safe and claims about their effectiveness by drug companies were 'poetic licence'. She described what was happening as a 'horrid act of human annihilation'. The nurse said that management had instigated a policy of not providing a Patient Information Leaflet (PIL) before people were 'vaccinated' even though health care professionals are supposed to do this according to protocol. Patients should also be told that they are taking part in an ongoing clinical trial. Her challenges to what is happening had seen her excluded from meetings and ridiculed in others. She said she was told to 'watch my step ... or I would find myself surplus to requirements'. The nurse, who spoke anonymously in fear of her career, said she asked her NHS manager why he/she was content with taking part in genocide against those having the 'vaccines'. The reply was that everyone had to play their part and to 'put up, shut up, and get it done'. Government was 'leaning heavily' on NHS management which was clearly leaning heavily on staff. This is how the global 'medical' hierarchy operates and it starts with the Cult and its World Health Organization.

She told the story of a doctor who had the Pfizer jab and when questioned had no idea what was in it. The doctor had never read the literature. We have to stop treating doctors as intellectual giants when so many are moral and medical pygmies. The doctor did not even know that the 'vaccines' were not fully approved or that their trials were ongoing. They were, however, asking their patients if they minded taking part in follow-ups for research purposes – yes, the *ongoing clinical trial*. The nurse said the doctor's ignorance was not rare and she had spoken to a hospital consultant who had the jab without any idea of the background or that the 'trials' had not been completed. Nurses and pharmacists had shown the same ignorance.

'My NHS colleagues have forsaken their duty of care, broken their code of conduct – Hippocratic Oath – and have been brainwashed just the same as the majority of the UK public through propaganda ...' She said she had not been able to recruit a single NHS colleague, doctor, nurse or pharmacist to stand with her and speak out. Her union had refused to help. She said that if the genocide came to light she would not hesitate to give evidence at a Nuremberg-type trial against those in power who could have affected the outcomes but didn't.

### **And all for what?**

To put the nonsense into perspective let's say the 'virus' does exist and let's go completely crazy and accept that the official manipulated figures for cases and deaths are accurate. *Even then* a study by Stanford University epidemiologist Dr John Ioannidis published on the World Health Organization website produced an average infection to fatality rate of ... *0.23 percent!* Ioannidis said: 'If one could sample equally from all locations globally, the median infection fatality rate might even be substantially lower than the 0.23% observed in my analysis.' For healthy people under 70 it was ... *0.05 percent!* This compares with the 3.4 percent claimed by the Cult-owned World Health Organization when the hoax was first played and maximum fear needed to be generated. An updated Stanford study in April, 2021, put the 'infection' to 'fatality' rate at just 0.15 percent. Another team of scientists led by Megan O'Driscoll and Henrik Salje studied data from 45 countries and published their findings on the Nature website. For children and young people the figure is so small it virtually does not register although authorities will be hyping dangers to the young when they introduce DNA-manipulating 'vaccines' for children. The O'Driscoll study produced an average infection-fatality figure of 0.003 for children from birth to four; 0.001 for 5 to 14; 0.003 for 15 to 19; and it was still only 0.456 up to 64. To claim that children must be 'vaccinated' to protect them from 'Covid' is an obvious lie and so there must be another reason and there is. What's more the average age of a 'Covid' death is akin

to the average age that people die in general. The average age of death in England is about 80 for men and 83 for women. The average age of death from alleged 'Covid' is between 82 and 83. California doctors, Dan Erickson and Artin Massihi, said at their April media conference that projection models of millions of deaths had been 'woefully inaccurate'. They produced detailed figures showing that Californians had a 0.03 chance of dying from 'Covid' based on the number of people who tested positive (with a test not testing for the 'virus'). Erickson said there was a 0.1 percent chance of dying from 'Covid' in the *state* of New York, not just the city, and a 0.05 percent chance in Spain, a centre of 'Covid-19' hysteria at one stage. The Stanford studies supported the doctors' data with fatality rate estimates of 0.23 and 0.15 percent. How close are these figures to my estimate of *zero*? Death-rate figures claimed by the World Health Organization at the start of the hoax were some 15 times higher. The California doctors said there was no justification for lockdowns and the economic devastation they caused. Everything they had ever learned about quarantine was that you quarantine the *sick* and not the healthy. They had never seen this before and it made no medical sense.

Why in the in the light of all this would governments and medical systems the world over say that billions must go under house arrest; lose their livelihood; in many cases lose their mind, their health and their life; force people to wear masks dangerous to health and psychology; make human interaction and even family interaction a criminal offence; ban travel; close restaurants, bars, watching live sport, concerts, theatre, and any activity involving human togetherness and discourse; and closing schools to isolate children from their friends and cause many to commit suicide in acts of hopelessness and despair? The California doctors said lockdown consequences included increased child abuse, partner abuse, alcoholism, depression, and other impacts they were seeing every day. Who would do that to the entire human race if not mentally-ill psychopaths of almost unimaginable extremes like Bill Gates? We must face the reality of what we are dealing with and come out of



denial. Fascism and tyranny are made possible only by the target population submitting and acquiescing to fascism and tyranny. The whole of human history shows that to be true. Most people naively and unquestioning believed what they were told about a 'deadly virus' and meekly and weakly submitted to house arrest. Those who didn't believe it – at least in total – still submitted in fear of the consequences of not doing so. For the rest who wouldn't submit draconian fines have been imposed, brutal policing by psychopaths *for* psychopaths, and condemnation from the meek and weak who condemn the Pushbackers on behalf of the very force that has them, too, in its gun sights. 'Pathetic' does not even begin to suffice. Britain's brainless 'Health' Secretary Matt Hancock warned anyone lying to border officials about returning from a list of 'hotspot' countries could face a jail sentence of up to ten years which is more than for racially-aggravated assault, incest and attempting to have sex with a child under 13. Hancock is a lunatic, but he has the state apparatus behind him in a Cult-led chain reaction and the same with UK 'Vaccine Minister' Nadhim Zahawi, a prominent member of the mega-Cult secret society, Le Cercle, which featured in my earlier books. The Cult enforces its will on governments and medical systems; government and medical systems enforce their will on business and police; business enforces its will on staff who enforce it on customers; police enforce the will of the Cult on the population and play their essential part in creating a world of fascist control that their own children and grandchildren will have to live in their entire lives. It is a hierarchical pyramid of imposition and acquiescence and, yes indeed, of clinical insanity.

Does anyone bright enough to read this book have to ask what the answer is? I think not, but I will reveal it anyway in the fewest of syllables: Tell the psychos and their moronic lackeys to fuck off and let's get on with our lives. We are many – They are few.

## CHAPTER SEVEN

### **War on your mind**

*One believes things because one has been conditioned to believe them*

*Aldous Huxley, Brave New World*

I have described the 'Covid' hoax as a 'Psyop' and that is true in every sense and on every level in accordance with the definition of that term which is psychological warfare. Break down the 'Covid pandemic' to the foundation themes and it is psychological warfare on the human individual and collective mind.

The same can be said for the entire human belief system involving every subject you can imagine. Huxley was right in his contention that people believe what they are conditioned to believe and this comes from the repetition throughout their lives of the same falsehoods. They spew from government, corporations, media and endless streams of 'experts' telling you what the Cult wants you to believe and often believing it themselves (although *far* from always). 'Experts' are rewarded with 'prestigious' jobs and titles and as agents of perceptual programming with regular access to the media. The Cult has to control the narrative – control *information* – or they lose control of the vital, crucial, without-which-they-cannot-prevail public perception of reality. The foundation of that control today is the Internet made possible by the Defense Advanced Research Projects Agency (DARPA), the incredibly sinister technological arm of the Pentagon. The Internet is the result of military technology.

DARPA openly brags about establishing the Internet which has been a long-term project to lasso the minds of the global population. I have said for decades the plan is to control information to such an extreme that eventually no one would see or hear anything that the Cult does not approve. We are closing in on that end with ferocious censorship since the 'Covid' hoax began and in my case it started back in the 1990s in terms of books and speaking venues. I had to create my own publishing company in 1995 precisely because no one else would publish my books even then. I think they're all still running.

## **Cult Internet**

To secure total control of information they needed the Internet in which pre-programmed algorithms can seek out 'unclean' content for deletion and even stop it being posted in the first place. The Cult had to dismantle print and non-Internet broadcast media to ensure the transfer of information to the appropriate-named 'Web' – a critical expression of the *Cult* web. We've seen the ever-quickening demise of traditional media and control of what is left by a tiny number of corporations operating worldwide. Independent journalism in the mainstream is already dead and never was that more obvious than since the turn of 2020. The Cult wants all information communicated via the Internet to globally censor and allow the plug to be pulled any time. Lockdowns and forced isolation has meant that communication between people has been through electronic means and no longer through face-to-face discourse and discussion. Cult psychopaths have targeted the bars, restaurants, sport, venues and meeting places in general for this reason. None of this is by chance and it's to stop people gathering in any kind of privacy or number while being able to track and monitor all Internet communications and block them as necessary. Even private messages between individuals have been censored by these fascists that control Cult fronts like Facebook, Twitter, Google and YouTube which are all officially run by Sabbatian place-people and from the background by higher-level Sabbatian place people.

Facebook, Google, Amazon and their like were seed-funded and supported into existence with money-no-object infusions of funds either directly or indirectly from DARPA and CIA technology arm In-Q-Tel. The Cult plays the long game and prepares very carefully for big plays like 'Covid'. Amazon is another front in the psychological war and pretty much controls the global market in book sales and increasingly publishing. Amazon's limitless funds have deleted fantastic numbers of independent publishers to seize global domination on the way to deciding which books can be sold and circulated and which cannot. Moves in that direction are already happening. Amazon's leading light Jeff Bezos is the grandson of Lawrence Preston Gise who worked with DARPA predecessor ARPA. Amazon has big connections to the CIA and the Pentagon. The plan I have long described went like this:

1. Employ military technology to establish the Internet.
2. Sell the Internet as a place where people can freely communicate without censorship and allow that to happen until the Net becomes the central and irreversible pillar of human society. If the Internet had been highly censored from the start many would have rejected it.
3. Fund and manipulate major corporations into being to control the circulation of information on your Internet using cover stories about geeks in garages to explain how they came about. Give them unlimited funds to expand rapidly with no need to make a profit for years while non-Cult companies who need to balance the books cannot compete. You know that in these circumstances your Googles, YouTubes, Facebooks and Amazons are going to secure near monopolies by either crushing or buying up the opposition.
4. Allow freedom of expression on both the Internet and communication platforms to draw people in until the Internet is the central and irreversible pillar of human society and your communication corporations have reached a stage of near monopoly domination.
5. Then unleash your always-planned frenzy of censorship on the basis of 'where else are you going to go?' and continue to expand that until nothing remains that the Cult does not want its human targets to see.

The process was timed to hit the 'Covid' hoax to ensure the best chance possible of controlling the narrative which they knew they had to do at all costs. They were, after all, about to unleash a 'deadly virus' that didn't really exist. If you do that in an environment of free-flowing information and opinion you would be dead in the

water before you could say Gates is a psychopath. The network was in place through which the Cult-created-and-owned World Health Organization could dictate the 'Covid' narrative and response policy slavishly supported by Cult-owned Internet communication giants and mainstream media while those telling a different story were censored. Google, YouTube, Facebook and Twitter openly announced that they would do this. What else would we expect from Cult-owned operations like Facebook which former executives have confirmed set out to make the platform more addictive than cigarettes and coldly manipulates emotions of its users to sow division between people and groups and scramble the minds of the young? If Zuckerberg lives out the rest of his life without going to jail for crimes against humanity, and most emphatically against the young, it will be a travesty of justice. Still, no matter, cause and effect will catch up with him eventually and the same with Sergey Brin and Larry Page at Google with its CEO Sundar Pichai who fix the Google search results to promote Cult narratives and hide the opposition. Put the same key words into Google and other search engines like DuckDuckGo and you will see how different results can be. Wikipedia is another intensely biased 'encyclopaedia' which skews its content to the Cult agenda. YouTube links to Wikipedia's version of 'Covid' and 'climate change' on video pages in which experts in their field offer a different opinion (even that is increasingly rare with Wojcicki censorship). Into this 'Covid' silence-them network must be added government media censors, sorry 'regulators', such as Ofcom in the UK which imposed tyrannical restrictions on British broadcasters that had the effect of banning me from ever appearing. Just to debate with me about my evidence and views on 'Covid' would mean breaking the fascistic impositions of Ofcom and its CEO career government bureaucrat Melanie Dawes. Gutless British broadcasters tremble at the very thought of fascist Ofcom.

## **Psychos behind 'Covid'**

The reason for the 'Covid' catastrophe in all its facets and forms can be seen by whom and what is driving the policies worldwide in such a coordinated way. Decisions are not being made to protect health, but to target psychology. The dominant group guiding and 'advising' government policy are not medical professionals. They are psychologists and behavioural scientists. Every major country has its own version of this phenomenon and I'll use the British example to show how it works. In many ways the British version has been affecting the wider world in the form of the huge behaviour manipulation network in the UK which operates in other countries. The network involves private companies, government, intelligence and military. The Cabinet Office is at the centre of the government 'Covid' Psyop and part-owns, with 'innovation charity' Nesta, the Behavioural Insights Team (BIT) which claims to be independent of government but patently isn't. The BIT was established in 2010 and its job is to manipulate the psyche of the population to acquiesce to government demands and so much more. It is also known as the 'Nudge Unit', a name inspired by the 2009 book by two ultra-Zionists, Cass Sunstein and Richard Thaler, called *Nudge: Improving Decisions About Health, Wealth, and Happiness*. The book, as with the Behavioural Insights Team, seeks to 'nudge' behaviour (manipulate it) to make the public follow patterns of action and perception that suit those in authority (the Cult). Sunstein is so skilled at this that he advises the World Health Organization and the UK Behavioural Insights Team and was Administrator of the White House Office of Information and Regulatory Affairs in the Obama administration. Biden appointed him to the Department of Homeland Security – another ultra-Zionist in the fold to oversee new immigration laws which is another policy the Cult wants to control. Sunstein is desperate to silence anyone exposing conspiracies and co-authored a 2008 report on the subject in which suggestions were offered to ban 'conspiracy theorizing' or impose 'some kind of tax, financial or otherwise, on those who disseminate such theories'. I guess a psychiatrist's chair is out of the question?

Sunstein's mate Richard Thaler, an 'academic affiliate' of the UK Behavioural Insights Team, is a proponent of 'behavioural economics' which is defined as the study of 'the effects of psychological, cognitive, emotional, cultural and social factors on the decisions of individuals and institutions'. Study the effects so they can be manipulated to be what you want them to be. Other leading names in the development of behavioural economics are ultra-Zionists Daniel Kahneman and Robert J. Shiller and they, with Thaler, won the Nobel Memorial Prize in Economic Sciences for their work in this field. The Behavioural Insights Team is operating at the heart of the UK government and has expanded globally through partnerships with several universities including Harvard, Oxford, Cambridge, University College London (UCL) and Pennsylvania. They claim to have 'trained' (reframed) 20,000 civil servants and run more than 750 projects involving 400 randomised controlled trials in dozens of countries' as another version of mind reframers Common Purpose. BIT works from its office in New York with cities and their agencies, as well as other partners, across the United States and Canada – this is a company part-owned by the British government Cabinet Office. An executive order by President Cult-servant Obama established a US Social and Behavioral Sciences Team in 2015. They all have the same reason for being and that's to brainwash the population directly and by brainwashing those in positions of authority.

### **'Covid' mind game**

Another prime aspect of the UK mind-control network is the 'independent' [joke] Scientific Pandemic Insights Group on Behaviours (SPI-B) which 'provides behavioural science advice aimed at anticipating and helping people adhere to interventions that are recommended by medical or epidemiological experts'. That means manipulating public perception and behaviour to do whatever government tells them to do. It's disgusting and if they really want the public to be 'safe' this lot should all be under lock and key. According to the government website SPI-B consists of

'behavioural scientists, health and social psychologists, anthropologists and historians' and advises the Whitty-Vallance-led Scientific Advisory Group for Emergencies (SAGE) which in turn advises the government on 'the science' (it doesn't) and 'Covid' policy. When politicians say they are being guided by 'the science' this is the rabble in each country they are talking about and that 'science' is dominated by behaviour manipulators to enforce government fascism through public compliance. The Behaviour Insight Team is headed by psychologist David Solomon Halpern, a visiting professor at King's College London, and connects with a national and global web of other civilian and military organisations as the Cult moves towards its goal of fusing them into one fascistic whole in every country through its 'Fusion Doctrine'. The behaviour manipulation network involves, but is not confined to, the Foreign Office; National Security Council; government communications headquarters (GCHQ); MI5; MI6; the Cabinet Office-based Media Monitoring Unit; and the Rapid Response Unit which 'monitors digital trends to spot emerging issues; including misinformation and disinformation; and identifies the best way to respond'.

There is also the 77th Brigade of the UK military which operates like the notorious Israeli military's Unit 8200 in manipulating information and discussion on the Internet by posing as members of the public to promote the narrative and discredit those who challenge it. Here we have the military seeking to manipulate *domestic* public opinion while the Nazis in government are fine with that. Conservative Member of Parliament Tobias Ellwood, an advocate of lockdown and control through 'vaccine passports', is a Lieutenant Colonel reservist in the 77th Brigade which connects with the military operation jHub, the 'innovation centre' for the Ministry of Defence and Strategic Command. jHub has also been involved with the civilian National Health Service (NHS) in 'symptom tracing' the population. The NHS is a key part of this mind control network and produced a document in December, 2020, explaining to staff how to use psychological manipulation with different groups and ages to get them to have the DNA-manipulating 'Covid vaccine'



that's designed to cumulatively rewrite human genetics. The document, called 'Optimising Vaccination Roll Out – Do's and Don'ts for all messaging, documents and "communications" in the widest sense', was published by NHS England and the NHS Improvement *Behaviour Change Unit* in partnership with Public Health England and Warwick Business School. I hear the mantra about 'save the NHS' and 'protect the NHS' when we need to scrap the NHS and start again. The current version is far too corrupt, far too anti-human and totally compromised by Cult operatives and their assets. UK government broadcast media censor Ofcom will connect into this web – as will the BBC with its tremendous Ofcom influence – to control what the public see and hear and dictate mass perception. Nuremberg trials must include personnel from all these organisations.

### **The fear factor**

The 'Covid' hoax has led to the creation of the UK Cabinet Office-connected Joint Biosecurity Centre (JBC) which is officially described as providing 'expert advice on pandemics' using its independent [all Cult operations are 'independent'] analytical function to provide real-time analysis about infection outbreaks to identify and respond to outbreaks of Covid-19'. Another role is to advise the government on a response to spikes in infections – 'for example by closing schools or workplaces in local areas where infection levels have risen'. Put another way, promoting the Cult agenda. The Joint Biosecurity Centre is modelled on the Joint Terrorism Analysis Centre which analyses intelligence to set 'terrorism threat levels' and here again you see the fusion of civilian and military operations and intelligence that has led to military intelligence producing documents about 'vaccine hesitancy' and how it can be combated. Domestic civilian matters and opinions should not be the business of the military. The Joint Biosecurity Centre is headed by Tom Hurd, director general of the Office for Security and Counter-Terrorism from the establishment-to-its-fingertips Hurd family. His father is former Foreign Secretary Douglas Hurd. How coincidental that Tom

Hurd went to the elite Eton College and Oxford University with Boris Johnson. Imperial College with its ridiculous computer modeller Neil Ferguson will connect with this gigantic web that will itself interconnect with similar set-ups in other major and not so major countries. Compared with this Cult network the politicians, be they Boris Johnson, Donald Trump or Joe Biden, are bit-part players 'following the science'. The network of psychologists was on the 'Covid' case from the start with the aim of generating maximum fear of the 'virus' to ensure compliance by the population. A government behavioural science group known as SPI-B produced a paper in March, 2020, for discussion by the main government science advisory group known as SAGE. It was headed 'Options for increasing adherence to social distancing measures' and it said the following in a section headed 'Persuasion':

- A substantial number of people still do not feel sufficiently personally threatened; it could be that they are reassured by the low death rate in their demographic group, although levels of concern may be rising. Having a good understanding of the risk has been found to be positively associated with adoption of COVID-19 social distancing measures in Hong Kong.
- The perceived level of personal threat needs to be increased among those who are complacent, using hard-hitting evaluation of options for increasing social distancing emotional messaging. To be effective this must also empower people by making clear the actions they can take to reduce the threat.
- Responsibility to others: There seems to be insufficient understanding of, or feelings of responsibility about, people's role in transmitting the infection to others ... Messaging about actions need to be framed positively in terms of protecting oneself and the community, and increase confidence that they will be effective.
- Some people will be more persuaded by appeals to play by the rules, some by duty to the community, and some to personal risk.

All these different approaches are needed. The messaging also needs to take account of the realities of different people's lives. Messaging needs to take account of the different motivational levers and circumstances of different people.

All this could be achieved the SPI-B psychologists said by *using the media to increase the sense of personal threat* which translates as terrify the shit out of the population, including children, so they all do what we want. That's not happened has it? Those excuses for 'journalists' who wouldn't know journalism if it bit them on the arse (the great majority) have played their crucial part in serving this Cult-government Psyop to enslave their own kids and grandkids. How they live with themselves I have no idea. The psychological war has been underpinned by constant government 'Covid' propaganda in almost every television and radio ad break, plus the Internet and print media, which has pounded out the fear with taxpayers footing the bill for their own programming. The result has been people terrified of a 'virus' that doesn't exist or one with a tiny fatality rate even if you believe it does. People walk down the street and around the shops wearing face-nappies damaging their health and psychology while others report those who refuse to be that naïve to the police who turn up in their own face-nappies. I had a cameraman come to my flat and he was so frightened of 'Covid' he came in wearing a mask and refused to shake my hand in case he caught something. He had – naïveitis – and the thought that he worked in the mainstream media was both depressing and made his behaviour perfectly explainable. The fear which has gripped the minds of so many and frozen them into compliance has been carefully cultivated by these psychologists who are really psychopaths. If lives get destroyed and a lot of young people commit suicide it shows our plan is working. SPI-B then turned to compulsion on the public to comply. 'With adequate preparation, rapid change can be achieved', it said. Some countries had introduced mandatory self-isolation on a wide scale without evidence of major public unrest and a large majority of the UK's population appeared to be supportive of more coercive measures with 64 percent of adults saying they would

support putting London under a lockdown (watch the 'polls' which are designed to make people believe that public opinion is in favour or against whatever the subject in hand).

For 'aggressive protective measures' to be effective, the SPI-B paper said, special attention should be devoted to those population groups that are more at risk. Translated from the Orwellian this means making the rest of population feel guilty for not protecting the 'vulnerable' such as old people which the Cult and its agencies were about to kill on an industrial scale with lockdown, lack of treatment and the Gates 'vaccine'. Psychopath psychologists sold their guilt-trip so comprehensively that Los Angeles County Supervisor Hilda Solis reported that children were apologising (from a distance) to their parents and grandparents for bringing 'Covid' into their homes and getting them sick. '... These apologies are just some of the last words that loved ones will ever hear as they die alone,' she said. Gut-wrenchingly Solis then used this childhood tragedy to tell children to stay at home and 'keep your loved ones alive'. Imagine heaping such potentially life-long guilt on a kid when it has absolutely nothing to do with them. These people are deeply disturbed and the psychologists behind this even more so.

### **Uncivil war – divide and rule**

Professional mind-controllers at SPI-B wanted the media to increase a sense of responsibility to others (do as you're told) and promote 'positive messaging' for those actions while in contrast to invoke 'social disapproval' by the unquestioning, obedient, community of anyone with a mind of their own. Again the compliant Goebbels-like media obliged. This is an old, old, trick employed by tyrannies the world over throughout human history. You get the target population to keep the target population in line – *your* line. SPI-B said this could 'play an important role in preventing anti-social behaviour or discouraging failure to enact pro-social behaviour'. For 'anti-social' in the Orwellian parlance of SPI-B see any behaviour that government doesn't approve. SPI-B recommendations said that 'social disapproval' should be accompanied by clear messaging and

promotion of strong collective identity – hence the government and celebrity mantra of ‘we’re all in this together’. Sure we are. The mind doctors have such contempt for their targets that they think some clueless comedian, actor or singer telling them to do what the government wants will be enough to win them over. We have had UK comedian Lenny Henry, actor Michael Caine and singer Elton John wheeled out to serve the propagandists by urging people to have the DNA-manipulating ‘Covid’ non-‘vaccine’. The role of Henry and fellow black celebrities in seeking to coax a ‘vaccine’ reluctant black community into doing the government’s will was especially stomach-turning. An emotion-manipulating script and carefully edited video featuring these black ‘celebs’ was such an insult to the intelligence of black people and where’s the self-respect of those involved selling their souls to a fascist government agenda? Henry said he heard black people’s ‘legitimate worries and concerns’, but people must ‘trust the facts’ when they were doing exactly that by not having the ‘vaccine’. They had to include the obligatory reference to Black Lives Matter with the line ... ‘Don’t let coronavirus cost even more black lives – because we matter’. My god, it was pathetic. ‘I know the vaccine is safe and what it does.’ How? ‘I’m a comedian and it says so in my script.’

SPI-B said social disapproval needed to be carefully managed to avoid victimisation, scapegoating and misdirected criticism, but they knew that their ‘recommendations’ would lead to exactly that and the media were specifically used to stir-up the divide-and-conquer hostility. Those who conform like good little baa, baas, are praised while those who have seen through the tidal wave of lies are ‘Covidiot’s’. The awake have been abused by the fast asleep for not conforming to fascism and impositions that the awake know are designed to endanger their health, dehumanise them, and tear asunder the very fabric of human society. We have had the curtain-twitchers and morons reporting neighbours and others to the face-napped police for breaking ‘Covid rules’ with fascist police delighting in posting links and phone numbers where this could be done. The Cult cannot impose its will without a compliant police

and military or a compliant population willing to play their part in enslaving themselves and their kids. The words of a pastor in Nazi Germany are so appropriate today:

First they came for the socialists and I did not speak out because I was not a socialist.

Then they came for the trade unionists and I did not speak out because I was not a trade unionist.

Then they came for the Jews and I did not speak out because I was not a Jew.

Then they came for me and there was no one left to speak for me.

Those who don't learn from history are destined to repeat it and so many are.

### **'Covid' rules: Rewiring the mind**

With the background laid out to this gigantic national and global web of psychological manipulation we can put 'Covid' rules into a clear and sinister perspective. Forget the claims about protecting health. 'Covid' rules are about dismantling the human mind, breaking the human spirit, destroying self-respect, and then putting Humpty Dumpty together again as a servile, submissive slave. Social isolation through lockdown and distancing have devastating effects on the human psyche as the psychological psychopaths well know and that's the real reason for them. Humans need contact with each other, discourse, closeness and touch, or they eventually, and literally, go crazy. Masks, which I will address at some length, fundamentally add to the effects of isolation and the Cult agenda to dehumanise and de-individualise the population. To do this while knowing – in fact *seeking* – this outcome is the very epitome of evil and psychologists involved in this *are* the epitome of evil. They must like all the rest of the Cult demons and their assets stand trial for crimes against humanity on a scale that defies the imagination. Psychopaths in uniform use isolation to break enemy troops and agents and make them subservient and submissive to tell what they know. The technique is rightly considered a form of torture and

torture is most certainly what has been imposed on the human population.

Clinically-insane American psychologist Harry Harlow became famous for his isolation experiments in the 1950s in which he separated baby monkeys from their mothers and imprisoned them for months on end in a metal container or 'pit of despair'. They soon began to show mental distress and depression as any idiot could have predicted. Harlow put other monkeys in steel chambers for three, six or twelve months while denying them any contact with animals or humans. He said that the effects of total social isolation for six months were 'so devastating and debilitating that we had assumed initially that twelve months of isolation would not produce any additional decrement'; but twelve months of isolation 'almost obliterated the animals socially'. This is what the Cult and its psychopaths are doing to you and your children. Even monkeys in partial isolation in which they were not allowed to form relationships with other monkeys became 'aggressive and hostile, not only to others, but also towards their own bodies'. We have seen this in the young as a consequence of lockdown. UK government psychopaths launched a public relations campaign telling people not to hug each other even after they received the 'Covid-19 vaccine' which we were told with more lies would allow a return to 'normal life'. A government source told *The Telegraph*: 'It will be along the lines that it is great that you have been vaccinated, but if you are going to visit your family and hug your grandchildren there is a chance you are going to infect people you love.' The source was apparently speaking from a secure psychiatric facility. Janet Lord, director of Birmingham University's Institute of Inflammation and Ageing, said that parents and grandparents should avoid hugging their children. Well, how can I put it, Ms Lord? Fuck off. Yep, that'll do.

## **Destroying the kids – where are the parents?**

Observe what has happened to people enslaved and isolated by lockdown as suicide and self-harm has soared worldwide,

particularly among the young denied the freedom to associate with their friends. A study of 49,000 people in English-speaking countries concluded that almost half of young adults are at clinical risk of mental health disorders. A national survey in America of 1,000 currently enrolled high school and college students found that 5 percent reported attempting suicide during the pandemic. Data from the US CDC's National Syndromic Surveillance Program from January 1st to October 17th, 2020, revealed a 31 percent increase in mental health issues among adolescents aged 12 to 17 compared with 2019. The CDC reported that America in general suffered the biggest drop in life expectancy since World War Two as it fell by a year in the first half of 2020 as a result of 'deaths of despair' – overdoses and suicides. Deaths of despair have leapt by more than 20 percent during lockdown and include the highest number of fatal overdoses ever recorded in a single year – 81,000. Internet addiction is another consequence of being isolated at home which lowers interest in physical activities as kids fall into inertia and what's the point? Children and young people are losing hope and giving up on life, sometimes literally. A 14-year-old boy killed himself in Maryland because he had 'given up' when his school district didn't reopen; an 11-year-old boy shot himself during a zoom class; a teenager in Maine succumbed to the isolation of the 'pandemic' when he ended his life after experiencing a disrupted senior year at school. Children as young as nine have taken their life and all these stories can be repeated around the world. Careers are being destroyed before they start and that includes those in sport in which promising youngsters have not been able to take part. The plan of the psycho-psychologists is working all right. Researchers at Cambridge University found that lockdowns cause significant harm to children's mental health. Their study was published in the *Archives of Disease in Childhood*, and followed 168 children aged between 7 and 11. The researchers concluded:

During the UK lockdown, children's depression symptoms have increased substantially, relative to before lockdown. The scale of this effect has direct relevance for the continuation of different elements of lockdown policy, such as complete or partial school closures ...



... Specifically, we observed a statistically significant increase in ratings of depression, with a medium-to-large effect size. Our findings emphasise the need to incorporate the potential impact of lockdown on child mental health in planning the ongoing response to the global pandemic and the recovery from it.

Not a chance when the Cult's psycho-psychologists were getting exactly what they wanted. The UK's Royal College of Paediatrics and Child Health has urged parents to look for signs of eating disorders in children and young people after a three to four fold increase. Specialists say the 'pandemic' is a major reason behind the rise. You don't say. The College said isolation from friends during school closures, exam cancellations, loss of extra-curricular activities like sport, and an increased use of social media were all contributory factors along with fears about the virus (psycho-psychologists again), family finances, and students being forced to quarantine. Doctors said young people were becoming severely ill by the time they were seen with 'Covid' regulations reducing face-to-face consultations. Nor is it only the young that have been devastated by the psychopaths. Like all bullies and cowards the Cult is targeting the young, elderly, weak and infirm. A typical story was told by a British lady called Lynn Parker who was not allowed to visit her husband in 2020 for the last ten and half months of his life 'when he needed me most' between March 20th and when he died on December 19th. This vacates the criminal and enters the territory of evil. The emotional impact on the immune system alone is immense as are the number of people of all ages worldwide who have died as a result of Cult-demanded, Gates-demanded, lockdowns.

## **Isolation is torture**

The experience of imposing solitary confinement on millions of prisoners around the world has shown how a large percentage become 'actively psychotic and/or acutely suicidal'. Social isolation has been found to trigger 'a specific psychiatric syndrome, characterized by hallucinations; panic attacks; overt paranoia; diminished impulse control; hypersensitivity to external stimuli; and difficulties with thinking, concentration and memory'. Juan Mendez,

a United Nations rapporteur (investigator), said that isolation is a form of torture. Research has shown that even after isolation prisoners find it far more difficult to make social connections and I remember chatting to a shop assistant after one lockdown who told me that when her young son met another child again he had no idea how to act or what to do. Hannah Flanagan, Director of Emergency Services at Journey Mental Health Center in Dane County, Wisconsin, said: 'The specificity about Covid social distancing and isolation that we've come across as contributing factors to the suicides are really new to us this year.' But they are not new to those that devised them. They are getting the effect they want as the population is psychologically dismantled to be rebuilt in a totally different way. Children and the young are particularly targeted. They will be the adults when the full-on fascist AI-controlled technocracy is planned to be imposed and they are being prepared to meekly submit. At the same time older people who still have a memory of what life was like before – and how fascist the new normal really is – are being deleted. You are going to see efforts to turn the young against the old to support this geriatric genocide. Hannah Flanagan said the big increase in suicide in her county proved that social isolation is not only harmful, but deadly. Studies have shown that isolation from others is one of the main risk factors in suicide and even more so with women. Warnings that lockdown could create a 'perfect storm' for suicide were ignored. After all this was one of the *reasons* for lockdown. Suicide, however, is only the most extreme of isolation consequences. There are many others. Dr Dhruv Khullar, assistant professor of healthcare policy at Weill Cornell Medical College, said in a *New York Times* article in 2016 long before the fake 'pandemic':

A wave of new research suggests social separation is bad for us. Individuals with less social connection have disrupted sleep patterns, altered immune systems, more inflammation and higher levels of stress hormones. One recent study found that isolation increases the risk of heart disease by 29 percent and stroke by 32 percent. Another analysis that pooled data from 70 studies and 3.4 million people found that socially isolated individuals had a 30 percent higher risk of dying in the next seven years, and that this effect was largest in middle age.

Loneliness can accelerate cognitive decline in older adults, and isolated individuals are twice as likely to die prematurely as those with more robust social interactions. These effects start early: Socially isolated children have significantly poorer health 20 years later, even after controlling for other factors. All told, loneliness is as important a risk factor for early death as obesity and smoking.

There you have proof from that one article alone four years before 2020 that those who have enforced lockdown, social distancing and isolation knew what the effect would be and that is even more so with professional psychologists that have been driving the policy across the globe. We can go back even further to the years 2000 and 2003 and the start of a major study on the effects of isolation on health by Dr Janine Gronewold and Professor Dirk M. Hermann at the University Hospital in Essen, Germany, who analysed data on 4,316 people with an average age of 59 who were recruited for the long-term research project. They found that socially isolated people are more than 40 percent more likely to have a heart attack, stroke, or other major cardiovascular event and nearly 50 percent more likely to die from any cause. Given the financial Armageddon unleashed by lockdown we should note that the study found a relationship between increased cardiovascular risk and lack of financial support. After excluding other factors social isolation was still connected to a 44 percent increased risk of cardiovascular problems and a 47 percent increased risk of death by any cause. Lack of financial support was associated with a 30 percent increase in the risk of cardiovascular health events. Dr Gronewold said it had been known for some time that feeling lonely or lacking contact with close friends and family can have an impact on physical health and the study had shown that having strong social relationships is of high importance for heart health. Gronewold said they didn't understand yet why people who are socially isolated have such poor health outcomes, but this was obviously a worrying finding, particularly during these times of prolonged social distancing. Well, it can be explained on many levels. You only have to identify the point in the body where people feel loneliness and missing people they are parted from – it's in the centre of the chest where they feel the ache of loneliness and the ache of missing people. 'My heart aches for

you' ... 'My heart aches for some company.' I will explain this more in the chapter Escaping Wetiko, but when you realise that the body is the mind – they are expressions of each other – the reason why state of the mind dictates state of the body becomes clear.

American psychologist Ranjit Powar was highlighting the effects of lockdown isolation as early as April, 2020. She said humans have evolved to be social creatures and are wired to live in interactive groups. Being isolated from family, friends and colleagues could be unbalancing and traumatic for most people and could result in short or even long-term psychological and physical health problems. An increase in levels of anxiety, aggression, depression, forgetfulness and hallucinations were possible psychological effects of isolation. 'Mental conditions may be precipitated for those with underlying pre-existing susceptibilities and show up in many others without any pre-condition.' Powar said personal relationships helped us cope with stress and if we lost this outlet for letting off steam the result can be a big emotional void which, for an average person, was difficult to deal with. 'Just a few days of isolation can cause increased levels of anxiety and depression' – so what the hell has been the effect on the global population of *18 months* of this at the time of writing? Powar said: 'Add to it the looming threat of a dreadful disease being repeatedly hammered in through the media and you have a recipe for many shades of mental and physical distress.' For those with a house and a garden it is easy to forget that billions have had to endure lockdown isolation in tiny overcrowded flats and apartments with nowhere to go outside. The psychological and physical consequences of this are unimaginable and with lunatic and abusive partners and parents the consequences have led to tremendous increases in domestic and child abuse and alcoholism as people seek to shut out the horror. Ranjit Powar said:

Staying in a confined space with family is not all a rosy picture for everyone. It can be extremely oppressive and claustrophobic for large low-income families huddled together in small single-room houses. Children here are not lucky enough to have many board/electronic games or books to keep them occupied.

Add to it the deep insecurity of running out of funds for food and basic necessities. On the other hand, there are people with dysfunctional family dynamics, such as domineering, abusive or alcoholic partners, siblings or parents which makes staying home a period of trial. Incidence of suicide and physical abuse against women has shown a worldwide increase. Heightened anxiety and depression also affect a person's immune system, making them more susceptible to illness.

To think that Powar's article was published on April 11th, 2020.

## **Six-foot fantasy**

Social (unsocial) distancing demanded that people stay six feet or two metres apart. UK government advisor Robert Dingwall from the New and Emerging Respiratory Virus Threats Advisory Group said in a radio interview that the two-metre rule was 'conjured up out of nowhere' and was not based on science. No, it was not based on *medical* science, but it didn't come out of nowhere. The distance related to *psychological* science. Six feet/two metres was adopted in many countries and we were told by people like the criminal Anthony Fauci and his ilk that it was founded on science. Many schools could not reopen because they did not have the space for six-foot distancing. Then in March, 2021, after a year of six-foot 'science', a study published in the *Journal of Infectious Diseases* involving more than 500,000 students and almost 100,000 staff over 16 weeks revealed no significant difference in 'Covid' cases between six feet and three feet and Fauci changed his tune. Now three feet was okay. There is no difference between six feet and three *inches* when there is no 'virus' and they got away with six feet for psychological reasons for as long as they could. I hear journalists and others talk about 'unintended consequences' of lockdown. They are not *unintended* at all; they have been coldly-calculated for a specific outcome of human control and that's why super-psychopaths like Gates have called for them so vehemently. Super-psychopath psychologists have demanded them and psychopathic or clueless, spineless, politicians have gone along with them by 'following the science'. But it's not science at all. 'Science' is not what is; it's only what people can be manipulated to believe it is. The whole 'Covid' catastrophe is

founded on mind control. Three word or three statement mantras issued by the UK government are a well-known mind control technique and so we've had 'Stay home/protect the NHS/save lives', 'Stay alert/control the virus/save lives' and 'hands/face/space'. One of the most vocal proponents of extreme 'Covid' rules in the UK has been Professor Susan Michie, a member of the British Communist Party, who is not a medical professional. Michie is the director of the Centre for Behaviour Change at University College London. She is a *behavioural psychologist* and another filthy rich 'Marxist' who praised China's draconian lockdown. She was known by fellow students at Oxford University as 'Stalin's nanny' for her extreme Marxism. Michie is an influential member of the UK government's Scientific Advisory Group for Emergencies (SAGE) and behavioural manipulation groups which have dominated 'Covid' policy. She is a consultant adviser to the World Health Organization on 'Covid-19' and behaviour. Why the hell are lockdowns anything to do with her when they are claimed to be about health? Why does a behavioural psychologist from a group charged with changing the behaviour of the public want lockdown, human isolation and mandatory masks? Does that question really need an answer? Michie *absolutely* has to explain herself before a Nuremberg court when humanity takes back its world again and even more so when you see the consequences of masks that she demands are compulsory. This is a Michie classic:

The benefits of getting primary school children to wear masks is that regardless of what little degree of transmission is occurring in those age groups it could help normalise the practice. Young children wearing masks may be more likely to get their families to accept masks.

Those words alone should carry a prison sentence when you ponder on the callous disregard for children involved and what a statement it makes about the mind and motivations of Susan Michie. What a lovely lady and what she said there encapsulates the mentality of the psychopaths behind the 'Covid' horror. Let us compare what Michie said with a countrywide study in Germany published at [researchsquare.com](https://www.researchsquare.com) involving 25,000 school children and 17,854 health complaints submitted by parents. Researchers

found that masks are harming children physically, psychologically, and behaviourally with 24 health issues associated with mask wearing. They include: shortness of breath (29.7%); dizziness (26.4%); increased headaches (53%); difficulty concentrating (50%); drowsiness or fatigue (37%); and malaise (42%). Nearly a third of children experienced more sleep issues than before and a quarter developed new fears. Researchers found health issues and other impairments in 68 percent of masked children covering their faces for an average of 4.5 hours a day. Hundreds of those taking part experienced accelerated respiration, tightness in the chest, weakness, and short-term impairment of consciousness. A reminder of what Michie said again:

The benefits of getting primary school children to wear masks is that regardless of what little degree of transmission is occurring in those age groups it could help normalise the practice. Young children wearing masks may be more likely to get their families to accept masks.

Psychopaths in government and psychology now have children and young people – plus all the adults – wearing masks for hours on end while clueless teachers impose the will of the psychopaths on the young they should be protecting. What the hell are parents doing?

## **Cult lab rats**

We have some schools already imposing on students microchipped buzzers that activate when they get 'too close' to their pals in the way they do with lab rats. How apt. To the Cult and its brain-dead servants our children *are* lab rats being conditioned to be unquestioning, dehumanised slaves for the rest of their lives. Children and young people are being weaned and frightened away from the most natural human instincts including closeness and touch. I have tracked in the books over the years how schools were banning pupils from greeting each other with a hug and the whole Cult-induced Me Too movement has terrified men and boys from a relaxed and natural interaction with female friends and work colleagues to the point where many men try never to be in a room

alone with a woman that's not their partner. Airhead celebrities have as always played their virtue-signalling part in making this happen with their gross exaggeration. For every monster like Harvey Weinstein there are at least tens of thousands of men that don't treat women like that; but everyone must be branded the same and policy changed for them as well as the monster. I am going to be using the word 'dehumanise' many times in this chapter because that is what the Cult is seeking to do and it goes very deep as we shall see. Don't let them kid you that social distancing is planned to end one day. That's not the idea. We are seeing more governments and companies funding and producing wearable gadgets to keep people apart and they would not be doing that if this was meant to be short-term. A tech start-up company backed by GCHQ, the British Intelligence and military surveillance headquarters, has created a social distancing wrist sensor that alerts people when they get too close to others. The CIA has also supported tech companies developing similar devices. The wearable sensor was developed by Tended, one of a number of start-up companies supported by GCHQ (see the CIA and DARPA). The device can be worn on the wrist or as a tag on the waistband and will vibrate whenever someone wearing the device breaches social distancing and gets anywhere near natural human contact. The company had a lucky break in that it was developing a distancing sensor when the 'Covid' hoax arrived which immediately provided a potentially enormous market. How fortunate. The government in big-time Cult-controlled Ontario in Canada is investing \$2.5 million in wearable contact tracing technology that 'will alert users if they may have been exposed to the Covid-19 in the workplace and will beep or vibrate if they are within six feet of another person'. Facedrive Inc., the technology company behind this, was founded in 2016 with funding from the Ontario Together Fund and obviously they, too, had a prophet on the board of directors. The human surveillance and control technology is called TraceSCAN and would be worn by the human cyborgs in places such as airports, workplaces, construction sites, care homes and ... *schools*.



I emphasise schools with children and young people the prime targets. You know what is planned for society as a whole if you keep your eyes on the schools. They have always been places where the state program the next generation of slaves to be its compliant worker-ants – or Woker-ants these days; but in the mist of the ‘Covid’ madness they have been transformed into mind laboratories on a scale never seen before. Teachers and head teachers are just as programmed as the kids – often more so. Children are kept apart from human interaction by walk lanes, classroom distancing, staggered meal times, masks, and the rolling-out of buzzer systems. Schools are now physically laid out as a laboratory maze for lab-rats. Lunatics at a school in Anchorage, Alaska, who should be prosecuted for child abuse, took away desks and forced children to kneel (know your place) on a mat for five hours a day while wearing a mask and using their chairs as a desk. How this was supposed to impact on a ‘virus’ only these clinically insane people can tell you and even then it would be clap-trap. The school banned recess (interaction), art classes (creativity), and physical exercise (getting body and mind moving out of inertia). Everyone behind this outrage should be in jail or better still a mental institution. The behavioural manipulators are all for this dystopian approach to schools. Professor Susan Michie, the mind-doctor and British Communist Party member, said it was wrong to say that schools were safe. They had to be made so by ‘distancing’, masks and ventilation (sitting all day in the cold). I must ask this lady round for dinner on a night I know I am going to be out and not back for weeks. She probably wouldn’t be able to make it, anyway, with all the visits to her own psychologist she must have block-booked.

## **Masking identity**

I know how shocking it must be for you that a behaviour manipulator like Michie wants everyone to wear masks which have long been a feature of mind-control programs like the infamous MKUltra in the United States, but, there we are. We live and learn. I spent many years from 1996 to right across the millennium

researching mind control in detail on both sides of the Atlantic and elsewhere. I met a large number of mind-control survivors and many had been held captive in body and mind by MKUltra. MK stands for mind-control, but employs the German spelling in deference to the Nazis spirited out of Germany at the end of World War Two by Operation Paperclip in which the US authorities, with help from the Vatican, transported Nazi mind-controllers and engineers to America to continue their work. Many of them were behind the creation of NASA and they included Nazi scientist and SS officer Wernher von Braun who swapped designing V-2 rockets to bombard London with designing the Saturn V rockets that powered the NASA moon programme's Apollo craft. I think I may have mentioned that the Cult has no borders. Among Paperclip escapees was Josef Mengele, the Angel of Death in the Nazi concentration camps where he conducted mind and genetic experiments on children often using twins to provide a control twin to measure the impact of his 'work' on the other. If you want to observe the Cult mentality in all its extremes of evil then look into the life of Mengele. I have met many people who suffered mercilessly under Mengele in the United States where he operated under the name Dr Greene and became a stalwart of MKUltra programming and torture. Among his locations was the underground facility in the Mojave Desert in California called the China Lake Naval Weapons Station which is almost entirely below the surface. My books *The Biggest Secret*, *Children of the Matrix* and *The Perception Deception* have the detailed background to MKUltra.

The best-known MKUltra survivor is American Cathy O'Brien. I first met her and her late partner Mark Phillips at a conference in Colorado in 1996. Mark helped her escape and deprogram from decades of captivity in an offshoot of MKUltra known as Project Monarch in which 'sex slaves' were provided for the rich and famous including Father George Bush, Dick Cheney and the Clintons. Read Cathy and Mark's book *Trance-Formation of America* and if you are new to this you will be shocked to the core. I read it in 1996 shortly before, with the usual synchronicity of my life, I found

myself given a book table at the conference right next to hers. MKUltra never ended despite being very publicly exposed (only a small part of it) in the 1970s and continues in other guises. I am still in touch with Cathy. She contacted me during 2020 after masks became compulsory in many countries to tell me how they were used as part of MKUltra programming. I had been observing 'Covid regulations' and the relationship between authority and public for months. I saw techniques that I knew were employed on individuals in MKUltra being used on the global population. I had read many books and manuals on mind control including one called *Silent Weapons for Quiet Wars* which came to light in the 1980s and was a guide on how to perceptually program on a mass scale. 'Silent Weapons' refers to mind-control. I remembered a line from the manual as governments, medical authorities and law enforcement agencies have so obviously talked to – or rather at – the adult population since the 'Covid' hoax began as if they are children. The document said:

If a person is spoken to by a T.V. advertiser as if he were a twelve-year-old, then, due to suggestibility, he will, with a certain probability, respond or react to that suggestion with the uncritical response of a twelve-year-old and will reach in to his economic reservoir and deliver its energy to buy that product on impulse when he passes it in the store.

That's why authority has spoken to adults like children since all this began.

### **Why did Michael Jackson wear masks?**

Every aspect of the 'Covid' narrative has mind-control as its central theme. Cathy O'Brien wrote an article for [davidicke.com](http://davidicke.com) about the connection between masks and mind control. Her daughter Kelly who I first met in the 1990s was born while Cathy was still held captive in MKUltra. Kelly was forced to wear a mask as part of her programming from the age of *two* to dehumanise her, target her sense of individuality and reduce the amount of oxygen her brain and body received. *Bingo*. This is the real reason for compulsory

masks, why they have been enforced en masse, and why they seek to increase the number they demand you wear. First one, then two, with one disgraceful alleged 'doctor' recommending four which is nothing less than a death sentence. Where and how often they must be worn is being expanded for the purpose of mass mind control and damaging respiratory health which they can call 'Covid-19'. Canada's government headed by the man-child Justin Trudeau, says it's fine for children of two and older to wear masks. An insane 'study' in Italy involving just 47 children concluded there was no problem for babies as young as *four months* wearing them. Even after people were 'vaccinated' they were still told to wear masks by the criminal that is Anthony Fauci. Cathy wrote that mandating masks is allowing the authorities literally to control the air we breathe which is what was done in MKUltra. You might recall how the singer Michael Jackson wore masks and there is a reason for that. He was subjected to MKUltra mind control through Project Monarch and his psyche was scrambled by these simpletons. Cathy wrote:

In MKUltra Project Monarch mind control, Michael Jackson had to wear a mask to silence his voice so he could not reach out for help. Remember how he developed that whisper voice when he wasn't singing? Masks control the mind from the outside in, like the redefining of words is doing. By controlling what we can and cannot say for fear of being labeled racist or beaten, for example, it ultimately controls thought that drives our words and ultimately actions (or lack thereof).

Likewise, a mask muffles our speech so that we are not heard, which controls voice ... words ... mind. This is Mind Control. Masks are an obvious mind control device, and I am disturbed so many people are complying on a global scale. Masks depersonalize while making a person feel as though they have no voice. It is a barrier to others. People who would never choose to comply but are forced to wear a mask in order to keep their job, and ultimately their family fed, are compromised. They often feel shame and are subdued. People have stopped talking with each other while media controls the narrative.

The 'no voice' theme has often become literal with train passengers told not to speak to each other in case they pass on the 'virus', singing banned for the same reason and bonkers California officials telling people riding roller coasters that they cannot shout and scream. Cathy said she heard every day from healed MKUltra survivors who cannot wear a mask without flashing back on ways

their breathing was controlled – ‘from ball gags and penises to water boarding’. She said that through the years when she saw images of people in China wearing masks ‘due to pollution’ that it was really to control their oxygen levels. ‘I knew it was as much of a population control mechanism of depersonalisation as are burkas’, she said. Masks are another Chinese communist/fascist method of control that has been swept across the West as the West becomes China at lightning speed since we entered 2020.

## **Mask-19**

There are other reasons for mandatory masks and these include destroying respiratory health to call it ‘Covid-19’ and stunting brain development of children and the young. Dr Margarite Griesz-Brisson MD, PhD, is a Consultant Neurologist and Neurophysiologist and the Founder and Medical Director of the London Neurology and Pain Clinic. Her CV goes down the street and round the corner. She is clearly someone who cares about people and won’t parrot the propaganda. Griesz-Brisson has a PhD in pharmacology, with special interest in neurotoxicology, environmental medicine, neuroregeneration and neuroplasticity (the way the brain can change in the light of information received). She went public in October, 2020, with a passionate warning about the effects of mask-wearing laws:

The reinhalation of our exhaled air will without a doubt create oxygen deficiency and a flooding of carbon dioxide. We know that the human brain is very sensitive to oxygen deprivation. There are nerve cells for example in the hippocampus that can’t be longer than 3 minutes without oxygen – they cannot survive. The acute warning symptoms are headaches, drowsiness, dizziness, issues in concentration, slowing down of reaction time – reactions of the cognitive system.

Oh, I know, let’s tell bus, truck and taxi drivers to wear them and people working machinery. How about pilots, doctors and police? Griesz-Brisson makes the important point that while the symptoms she mentions may fade as the body readjusts this does not alter the fact that people continue to operate in oxygen deficit with long list of

potential consequences. She said it was well known that neurodegenerative diseases take years or decades to develop. 'If today you forget your phone number, the breakdown in your brain would have already started 20 or 30 years ago.' She said degenerative processes in your brain are getting amplified as your oxygen deprivation continues through wearing a mask. Nerve cells in the brain are unable to divide themselves normally in these circumstances and lost nerve cells will no longer be regenerated. 'What is gone is gone.' Now consider that people like shop workers and *schoolchildren* are wearing masks for hours every day. What in the name of sanity is going to be happening to them? 'I do not wear a mask, I need my brain to think', Griesz-Brisson said, 'I want to have a clear head when I deal with my patients and not be in a carbon dioxide-induced anaesthesia'. If you are told to wear a mask anywhere ask the organisation, police, store, whatever, for their risk assessment on the dangers and negative effects on mind and body of enforcing mask-wearing. They won't have one because it has never been done not even by government. All of them must be subject to class-action lawsuits as the consequences come to light. They don't do mask risk assessments for an obvious reason. They know what the conclusions would be and independent scientific studies that *have* been done tell a horror story of consequences.

### **'Masks are criminal'**

Dr Griesz-Brisson said that for children and adolescents, masks are an absolute no-no. They had an extremely active and adaptive immune system and their brain was incredibly active with so much to learn. 'The child's brain, or the youth's brain, is thirsting for oxygen.' The more metabolically active an organ was, the more oxygen it required; and in children and adolescents every organ was metabolically active. Griesz-Brisson said that to deprive a child's or adolescent's brain of oxygen, or to restrict it in any way, was not only dangerous to their health, it was absolutely criminal. 'Oxygen deficiency inhibits the development of the brain, and the damage that has taken place as a result CANNOT be reversed.' Mind

manipulators of MKUltra put masks on two-year-olds they wanted to neurologically rewire and you can see why. Griesz-Brisson said a child needs the brain to learn and the brain needs oxygen to function. 'We don't need a clinical study for that. This is simple, indisputable physiology.' Consciously and purposely induced oxygen deficiency was an absolutely deliberate health hazard, and an absolute medical contraindication which means that 'this drug, this therapy, this method or measure should not be used, and is not allowed to be used'. To coerce an entire population to use an absolute medical contraindication by force, she said, there had to be definite and serious reasons and the reasons must be presented to competent interdisciplinary and independent bodies to be verified and authorised. She had this warning of the consequences that were coming if mask wearing continued:

When, in ten years, dementia is going to increase exponentially, and the younger generations couldn't reach their god-given potential, it won't help to say 'we didn't need the masks'. I know how damaging oxygen deprivation is for the brain, cardiologists know how damaging it is for the heart, pulmonologists know how damaging it is for the lungs. Oxygen deprivation damages every single organ. Where are our health departments, our health insurance, our medical associations? It would have been their duty to be vehemently against the lockdown and to stop it and stop it from the very beginning.

Why do the medical boards issue punishments to doctors who give people exemptions? Does the person or the doctor seriously have to prove that oxygen deprivation harms people? What kind of medicine are our doctors and medical associations representing? Who is responsible for this crime? The ones who want to enforce it? The ones who let it happen and play along, or the ones who don't prevent it?

All of the organisations and people she mentions there either answer directly to the Cult or do whatever hierarchical levels above them tell them to do. The outcome of both is the same. 'It's not about masks, it's not about viruses, it's certainly not about your health', Griesz-Brisson said. 'It is about much, much more. I am not participating. I am not afraid.' They were taking our air to breathe and there was no unfounded medical exemption from face masks. Oxygen deprivation was dangerous for every single brain. It had to be the free decision of every human being whether they want to

wear a mask that was absolutely ineffective to protect themselves from a virus. She ended by rightly identifying where the responsibility lies for all this:

The imperative of the hour is personal responsibility. We are responsible for what we think, not the media. We are responsible for what we do, not our superiors. We are responsible for our health, not the World Health Organization. And we are responsible for what happens in our country, not the government.

Halle-bloody-lujah.

### **But surgeons wear masks, right?**

Independent studies of mask-wearing have produced a long list of reports detailing mental, emotional and physical dangers. What a definition of insanity to see police officers imposing mask-wearing on the public which will cumulatively damage their health while the police themselves wear masks that will cumulatively damage *their* health. It's utter madness and both public and police do this because 'the government says so' – yes a government of brain-donor idiots like UK Health Secretary Matt Hancock reading the 'follow the science' scripts of psychopathic, lunatic psychologists. The response you get from Stockholm syndrome sufferers defending the very authorities that are destroying them and their families is that 'surgeons wear masks'. This is considered the game, set and match that they must work and don't cause oxygen deficit. Well, actually, scientific studies have shown that they *do* and oxygen levels are monitored in operating theatres to compensate. Surgeons wear masks to stop spittle and such like dropping into open wounds – not to stop 'viral particles' which are so miniscule they can only be seen through an electron microscope. Holes in the masks are significantly bigger than 'viral particles' and if you sneeze or cough they will breach the mask. I watched an incredibly disingenuous 'experiment' that claimed to prove that masks work in catching 'virus' material from the mouth and nose. They did this with a slow motion camera and the mask did block big stuff which stayed inside the mask and



against the face to be breathed in or cause infections on the face as we have seen with many children. 'Viral particles', however, would never have been picked up by the camera as they came through the mask when they are far too small to be seen. The 'experiment' was therefore disingenuous *and* useless.

Studies have concluded that wearing masks in operating theatres (and thus elsewhere) make no difference to preventing infection while the opposite is true with toxic shite building up in the mask and this had led to an explosion in tooth decay and gum disease dubbed by dentists 'mask mouth'. You might have seen the Internet video of a furious American doctor urging people to take off their masks after a four-year-old patient had been rushed to hospital the night before and nearly died with a lung infection that doctors sourced to mask wearing. A study in the journal *Cancer Discovery* found that inhalation of harmful microbes can contribute to advanced stage lung cancer in adults and long-term use of masks can help breed dangerous pathogens. Microbiologists have said frequent mask wearing creates a moist environment in which microbes can grow and proliferate before entering the lungs. The Canadian Agency for Drugs and Technologies in Health, or CADTH, a Canadian national organisation that provides research and analysis to healthcare decision-makers, said this as long ago as 2013 in a report entitled 'Use of Surgical Masks in the Operating Room: A Review of the Clinical Effectiveness and Guidelines'. It said:

- No evidence was found to support the use of surgical face masks to reduce the frequency of surgical site infections
- No evidence was found on the effectiveness of wearing surgical face masks to protect staff from infectious material in the operating room.
- Guidelines recommend the use of surgical face masks by staff in the operating room to protect both operating room staff and patients (despite the lack of evidence).

We were told that the world could go back to 'normal' with the arrival of the 'vaccines'. When they came, fraudulent as they are, the story changed as I knew that it would. We are in the midst of transforming 'normal', not going back to it. Mary Ramsay, head of immunisation at Public Health England, echoed the words of US criminal Anthony Fauci who said masks and other regulations must stay no matter if people are vaccinated. The Fauci idiot continued to wear two masks – different colours so both could be clearly seen – after he *claimed* to have been vaccinated. Senator Rand Paul told Fauci in one exchange that his double-masks were 'theatre' and he was right. It's all theatre. Mary Ramsay back-tracked on the vaccine-return-to-normal theme when she said the public may need to wear masks and social-distance for years despite the jabs. 'People have got used to those lower-level restrictions now, and [they] can live with them', she said telling us what the idea has been all along. 'The vaccine does not give you a pass, even if you have had it, you must continue to follow all the guidelines' said a Public Health England statement which reneged on what we had been told before and made having the 'vaccine' irrelevant to 'normality' even by the official story. Spain's fascist government trumped everyone by passing a law mandating the wearing of masks on the beach and even when swimming in the sea. The move would have devastated what's left of the Spanish tourist industry, posed potential breathing dangers to swimmers and had Northern European sunbathers walking around with their forehead brown and the rest of their face white as a sheet. The ruling was so crazy that it had to be retracted after pressure from public and tourist industry, but it confirmed where the Cult wants to go with masks and how clinically insane authority has become. The determination to make masks permanent and hide the serious dangers to body and mind can be seen in the censorship of scientist Professor Denis Rancourt by Bill Gates-funded academic publishing website ResearchGate over his papers exposing the dangers and uselessness of masks. Rancourt said:

ResearchGate today has permanently locked my account, which I have had since 2015. Their reasons graphically show the nature of their attack against democracy, and their corruption of

science ... By their obscene non-logic, a scientific review of science articles reporting on harms caused by face masks has a 'potential to cause harm'. No criticism of the psychological device (face masks) is tolerated, if the said criticism shows potential to influence public policy.

This is what happens in a fascist world.

### **Where are the 'greens' (again)?**

Other dangers of wearing masks especially regularly relate to the inhalation of minute plastic fibres into the lungs and the deluge of discarded masks in the environment and oceans. Estimates predicted that more than 1.5 billion disposable masks will end up in the world's oceans every year polluting the water with tons of plastic and endangering marine wildlife. Studies project that humans are using 129 billion face masks each month worldwide – about three million a minute. Most are disposable and made from plastic, non-biodegradable microfibers that break down into smaller plastic particles that become widespread in ecosystems. They are littering cities, clogging sewage channels and turning up in bodies of water. I have written in other books about the immense amounts of microplastics from endless sources now being absorbed into the body. Rolf Halden, director of the Arizona State University (ASU) Biodesign Center for Environmental Health Engineering, was the senior researcher in a 2020 study that analysed 47 human tissue samples and found microplastics in all of them. 'We have detected these chemicals of plastics in every single organ that we have investigated', he said. I wrote in *The Answer* about the world being deluged with microplastics. A study by the Worldwide Fund for Nature (WWF) found that people are consuming on average every week some 2,000 tiny pieces of plastic mostly through water and also through marine life and the air. Every year humans are ingesting enough microplastics to fill a heaped dinner plate and in a life-time of 79 years it is enough to fill two large waste bins. Marco Lambertini, WWF International director general said: 'Not only are plastics polluting our oceans and waterways and killing marine life – it's in all of us and we can't escape consuming plastics,' American

geologists found tiny plastic fibres, beads and shards in rainwater samples collected from the remote slopes of the Rocky Mountain National Park near Denver, Colorado. Their report was headed: 'It is raining plastic.' Rachel Adams, senior lecturer in Biomedical Science at Cardiff Metropolitan University, said that among health consequences are internal inflammation and immune responses to a 'foreign body'. She further pointed out that microplastics become carriers of toxins including mercury, pesticides and dioxins (a known cause of cancer and reproductive and developmental problems). These toxins accumulate in the fatty tissues once they enter the body through microplastics. Now this is being compounded massively by people putting plastic on their face and throwing it away.

Workers exposed to polypropylene plastic fibres known as 'flock' have developed 'flock worker's lung' from inhaling small pieces of the flock fibres which can damage lung tissue, reduce breathing capacity and exacerbate other respiratory problems. *Now ...* commonly used surgical masks have three layers of melt-blown textiles made of ... polypropylene. We have billions of people putting these microplastics against their mouth, nose and face for hours at a time day after day in the form of masks. How does anyone think that will work out? I mean – what could possibly go wrong? We posted a number of scientific studies on this at [davidicke.com](http://davidicke.com), but when I went back to them as I was writing this book the links to the science research website where they were hosted were dead. Anything that challenges the official narrative in any way is either censored or vilified. The official narrative is so unsupportable by the evidence that only deleting the truth can protect it. A study by Chinese scientists still survived – with the usual twist which it why it was still active, I guess. Yes, they found that virtually all the masks they tested increased the daily intake of microplastic fibres, but people should still wear them because the danger from the 'virus' was worse said the crazy 'team' from the Institute of Hydrobiology in Wuhan. Scientists first discovered microplastics in lung tissue of some patients who died of lung cancer

in the 1990s. Subsequent studies have confirmed the potential health damage with the plastic degrading slowly and remaining in the lungs to accumulate in volume. Wuhan researchers used a machine simulating human breathing to establish that masks shed up to nearly 4,000 microplastic fibres in a month with reused masks producing more. Scientists said some masks are laced with toxic chemicals and a variety of compounds seriously restricted for both health and environmental reasons. They include cobalt (used in blue dye) and formaldehyde known to cause watery eyes, burning sensations in the eyes, nose, and throat, plus coughing, wheezing and nausea. No – that must be ‘Covid-19’.

### **Mask ‘worms’**

There is another and potentially even more sinister content of masks. Mostly new masks of different makes filmed under a microscope around the world have been found to contain strange black fibres or ‘worms’ that appear to move or ‘crawl’ by themselves and react to heat and water. The nearest I have seen to them are the self-replicating fibres that are pulled out through the skin of those suffering from Morgellons disease which has been connected to the phenomena of ‘chemtrails’ which I will bring into the story later on. Morgellons fibres continue to grow outside the body and have a form of artificial intelligence. Black ‘worm’ fibres in masks have that kind of feel to them and there is a nanotechnology technique called ‘worm micelles’ which carry and release drugs or anything else you want to deliver to the body. For sure the suppression of humanity by mind altering drugs is the Cult agenda big time and the more excuses they can find to gain access to the body the more opportunities there are to make that happen whether through ‘vaccines’ or masks pushed against the mouth and nose for hours on end.

So let us summarise the pros and cons of masks:

*Against masks:* Breathing in your own carbon dioxide; depriving the body and brain of sufficient oxygen; build-up of toxins in the mask that can be breathed into the lungs and cause rashes on the face and 'mask-mouth'; breathing microplastic fibres and toxic chemicals into the lungs; dehumanisation and deleting individualisation by literally making people faceless; destroying human emotional interaction through facial expression and deleting parental connection with their babies which look for guidance to their facial expression.

*For masks:* They don't protect you from a 'virus' that doesn't exist and even if it did 'viral' particles are so minute they are smaller than the holes in the mask.

Governments, police, supermarkets, businesses, transport companies, and all the rest who seek to impose masks have done no risk assessment on their consequences for health and psychology and are now open to group lawsuits when the impact becomes clear with a cumulative epidemic of respiratory and other disease. Authorities will try to exploit these effects and hide the real cause by dubbing them 'Covid-19'. Can you imagine setting out to force the population to wear health-destroying masks without doing any assessment of the risks? It is criminal and it is evil, but then how many people targeted in this way, who see their children told to wear them all day at school, have asked for a risk assessment? Billions can't be imposed upon by the few unless the billions allow it. Oh, yes, with just a tinge of irony, 85 percent of all masks made worldwide come from *China*.

### **Wash your hands in toxic shite**

'Covid' rules include the use of toxic sanitisers and again the health consequences of constantly applying toxins to be absorbed through the skin is obvious to any level of Renegade Mind. America's Food and Drug Administration (FDA) said that sanitisers are drugs and issued a warning about 75 dangerous brands which contain

methanol used in antifreeze and can cause death, kidney damage and blindness. The FDA circulated the following warning even for those brands that it claims to be safe:

Store hand sanitizer out of the reach of pets and children, and children should use it only with adult supervision. Do not drink hand sanitizer. This is particularly important for young children, especially toddlers, who may be attracted by the pleasant smell or brightly colored bottles of hand sanitizer.

Drinking even a small amount of hand sanitizer can cause alcohol poisoning in children. (However, there is no need to be concerned if your children eat with or lick their hands after using hand sanitizer.) During this coronavirus pandemic, poison control centers have had an increase in calls about accidental ingestion of hand sanitizer, so it is important that adults monitor young children's use.

Do not allow pets to swallow hand sanitizer. If you think your pet has eaten something potentially dangerous, call your veterinarian or a pet poison control center right away. Hand sanitizer is flammable and should be stored away from heat and flames. When using hand sanitizer, rub your hands until they feel completely dry before performing activities that may involve heat, sparks, static electricity, or open flames.

There you go, perfectly safe, then, and that's without even a mention of the toxins absorbed through the skin. Come on kids – sanitise your hands everywhere you go. It will save you from the 'virus'. Put all these elements together of the 'Covid' normal and see how much health and psychology is being cumulatively damaged, even devastated, to 'protect your health'. Makes sense, right? They are only imposing these things because they care, right? *Right?*

## **Submitting to insanity**

Psychological reframing of the population goes very deep and is done in many less obvious ways. I hear people say how contradictory and crazy 'Covid' rules are and how they are ever changing. This is explained away by dismissing those involved as idiots. It is a big mistake. The Cult is delighted if its cold calculation is perceived as incompetence and idiocy when it is anything but. Oh, yes, there are idiots within the system – lots of them – but they are *administering* the Cult agenda, mostly unknowingly. They are not deciding and dictating it. The bulwark against tyranny is self-

respect, always has been, always will be. It is self-respect that has broken every tyranny in history. By its very nature self-respect will not bow to oppression and its perpetrators. There is so little self-respect that it's always the few that overturn dictators. Many may eventually follow, but the few with the iron spines (self-respect) kick it off and generate the momentum. The Cult targets self-respect in the knowledge that once this has gone only submission remains. Crazy, contradictory, ever-changing 'Covid' rules are systematically applied by psychologists to delete self-respect. They *want* you to see that the rules make no sense. It is one thing to decide to do something when *you* have made the choice based on evidence and logic. You still retain your self-respect. It is quite another when you can see what you are being told to do is insane, ridiculous and makes no sense, and *yet you still do it*. Your self-respect is extinguished and this has been happening as ever more obviously stupid and nonsensical things have been demanded and the great majority have complied even when they can see they are stupid and nonsensical.

People walk around in face-nappies knowing they are damaging their health and make no difference to a 'virus'. They do it in fear of not doing it. I know it's daft, but I'll do it anyway. When that happens something dies inside of you and submissive reframing has begun. Next there's a need to hide from yourself that you have conceded your self-respect and you convince yourself that you have not really submitted to fear and intimidation. You begin to believe that you are complying with craziness because it's the right thing to do. When first you concede your self-respect of  $2+2 = 4$  to  $2+2 = 5$  you *know* you are compromising your self-respect. Gradually to avoid facing that fact you begin to *believe* that  $2+2=5$ . You have been reframed and I have been watching this process happening in the human psyche on an industrial scale. The Cult is working to break your spirit and one of its major tools in that war is humiliation. I read how former American soldier Bradley Manning (later Chelsea Manning after a sex-change) was treated after being jailed for supplying WikiLeaks with documents exposing the enormity of



government and elite mendacity. Manning was isolated in solitary confinement for eight months, put under 24-hour surveillance, forced to hand over clothing before going to bed, and stand naked for every roll call. This is systematic humiliation. The introduction of anal swab 'Covid' tests in China has been done for the same reason to delete self-respect and induce compliant submission. Anal swabs are mandatory for incoming passengers in parts of China and American diplomats have said they were forced to undergo the indignity which would have been calculated humiliation by the Cult-owned Chinese government that has America in its sights.

### **Government-people: An abusive relationship**

Spirit-breaking psychological techniques include giving people hope and apparent respite from tyranny only to take it away again. This happened in the UK during Christmas, 2020, when the psychopsychologists and their political lackeys announced an easing of restrictions over the holiday only to reimpose them almost immediately on the basis of yet another lie. There is a big psychological difference between getting used to oppression and being given hope of relief only to have that dashed. Psychologists know this and we have seen the technique used repeatedly. Then there is traumatising people before you introduce more extreme regulations that require compliance. A perfect case was the announcement by the dark and sinister Whitty and Vallance in the UK that 'new data' predicted that 4,000 could die every day over the winter of 2020/2021 if we did not lockdown again. I think they call it lying and after traumatising people with that claim out came Jackboot Johnson the next day with new curbs on human freedom. Psychologists know that a frightened and traumatised mind becomes suggestable to submission and behaviour reframing. Underpinning all this has been to make people fearful and suspicious of each other and see themselves as a potential danger to others. In league with deleted self-respect you have the perfect psychological recipe for self-loathing. The relationship between authority and public is now demonstrably the same as that of

subservience to an abusive partner. These are signs of an abusive relationship explained by psychologist Leslie Becker-Phelps:

**Psychological and emotional abuse:** Undermining a partner's self-worth with verbal attacks, name-calling, and belittling. Humiliating the partner in public, unjustly accusing them of having an affair, or interrogating them about their every behavior. Keeping partner confused or off balance by saying they were just kidding or blaming the partner for 'making' them act this way ... Feigning in public that they care while turning against them in private. This leads to victims frequently feeling confused, incompetent, unworthy, hopeless, and chronically self-doubting. [Apply these techniques to how governments have treated the population since New Year, 2020, and the parallels are obvious.]

**Physical abuse:** The abuser might physically harm their partner in a range of ways, such as grabbing, hitting, punching, or shoving them. They might throw objects at them or harm them with a weapon. [Observe the physical harm imposed by masks, lockdown, and so on.]

**Threats and intimidation:** One way abusers keep their partners in line is by instilling fear. They might be verbally threatening, or give threatening looks or gestures. Abusers often make it known that they are tracking their partner's every move. They might destroy their partner's possessions, threaten to harm them, or threaten to harm their family members. Not surprisingly, victims of this abuse often feel anxiety, fear, and panic. [No words necessary.]

**Isolation:** Abusers often limit their partner's activities, forbidding them to talk or interact with friends or family. They might limit access to a car or even turn off their phone. All of this might be done by physically holding them against their will, but is often accomplished through psychological abuse and intimidation. The more isolated a person feels, the fewer resources they have to help gain perspective on their situation and to escape from it. [No words necessary.]

**Economic abuse:** Abusers often make their partners beholden to them for money by controlling access to funds of any kind. They might prevent their partner from getting a job or withhold access to money they earn from a job. This creates financial dependency that makes leaving the relationship very difficult. [See destruction of livelihoods and the proposed meagre 'guaranteed income' so long as you do whatever you are told.]

**Using children:** An abuser might disparage their partner's parenting skills, tell their children lies about their partner, threaten to take custody of their children, or threaten to harm their children. These tactics instil fear and often elicit compliance. [See reframed social service mafia and how children are being mercilessly abused by the state over 'Covid' while their parents look on too frightened to do anything.]

A further recurring trait in an abusive relationship is the abused blaming themselves for their abuse and making excuses for the abuser. We have the public blaming each other for lockdown abuse by government and many making excuses for the government while attacking those who challenge the government. How often we have heard authorities say that rules are being imposed or reimposed only because people have refused to 'behave' and follow the rules. We don't want to do it – it's *you*.

Renegade Minds are an antidote to all of these things. They will never concede their self-respect no matter what the circumstances. Even when apparent humiliation is heaped upon them they laugh in its face and reflect back the humiliation on the abuser where it belongs. Renegade Minds will never wear masks they know are only imposed to humiliate, suppress and damage both physically and psychologically. Consequences will take care of themselves and they will never break their spirit or cause them to concede to tyranny. UK newspaper columnist Peter Hitchens was one of the few in the mainstream media to speak out against lockdowns and forced vaccinations. He then announced he had taken the jab. He wanted to see family members abroad and he believed vaccine passports were inevitable even though they had not yet been introduced. Hitchens

has a questioning and critical mind, but not a Renegade one. If he had no amount of pressure would have made him concede. Hitchens excused his action by saying that the battle has been lost. Renegade Minds never accept defeat when freedom is at stake and even if they are the last one standing the self-respect of not submitting to tyranny is more important than any outcome or any consequence.

That's why Renegade Minds are the only minds that ever changed anything worth changing.

## CHAPTER EIGHT

### **'Reframing' insanity**

*Insanity is relative. It depends on who has who locked in what cage*  
Ray Bradbury

**R**eframing' a mind means simply to change its perception and behaviour. This can be done subconsciously to such an extent that subjects have no idea they have been 'reframed' while to any observer changes in behaviour and attitudes are obvious.

Human society is being reframed on a ginormous scale since the start of 2020 and here we have the reason why psychologists rather than doctors have been calling the shots. Ask most people who have succumbed to 'Covid' reframing if they have changed and most will say 'no'; but they *have* and fundamentally. The Cult's long-game has been preparing for these times since way back and crucial to that has been to prepare both population and officialdom mentally and emotionally. To use the mind-control parlance they had to reframe the population with a mentality that would submit to fascism and reframe those in government and law enforcement to impose fascism or at least go along with it. The result has been the fact-deleted mindlessness of 'Wokeness' and officialdom that has either enthusiastically or unquestioningly imposed global tyranny demanded by reframed politicians on behalf of psychopathic and deeply evil cultists. 'Cognitive reframing' identifies and challenges the way someone sees the world in the form of situations, experiences and emotions and then restructures those perceptions to view the same set of circumstances in a different way. This can have

benefits if the attitudes are personally destructive while on the other side it has the potential for individual and collective mind control which the subject has no idea has even happened.

Cognitive therapy was developed in the 1960s by Aaron T. Beck who was born in Rhode Island in 1921 as the son of Jewish immigrants from the Ukraine. He became interested in the techniques as a treatment for depression. Beck's daughter Judith S. Beck is prominent in the same field and they founded the Beck Institute for Cognitive Behavior Therapy in Philadelphia in 1994. Cognitive reframing, however, began to be used worldwide by those with a very dark agenda. The Cult reframes politicians to change their attitudes and actions until they are completely at odds with what they once appeared to stand for. The same has been happening to government administrators at all levels, law enforcement, military and the human population. Cultists love mind control for two main reasons: It allows them to control what people think, do and say to secure agenda advancement and, by definition, it calms their legendary insecurity and fear of the unexpected. I have studied mind control since the time I travelled America in 1996. I may have been talking to next to no one in terms of an audience in those years, but my goodness did I gather a phenomenal amount of information and knowledge about so many things including the techniques of mind control. I have described this in detail in other books going back to *The Biggest Secret* in 1998. I met a very large number of people recovering from MKUltra and its offshoots and successors and I began to see how these same techniques were being used on the population in general. This was never more obvious than since the 'Covid' hoax began.

## **Reframing the enforcers**

I have observed over the last two decades and more the very clear transformation in the dynamic between the police, officialdom and the public. I tracked this in the books as the relationship mutated from one of serving the public to seeing them as almost the enemy and certainly a lower caste. There has always been a class divide

based on income and always been some psychopathic, corrupt, and big-I-am police officers. This was different. Wholesale change was unfolding in the collective dynamic; it was less about money and far more about position and perceived power. An us-and-them was emerging. Noses were lifted skyward by government administration and law enforcement and their attitude to the public they were *supposed* to be serving changed to one of increasing contempt, superiority and control. The transformation was so clear and widespread that it had to be planned. Collective attitudes and dynamics do not change naturally and organically that quickly on that scale. I then came across an organisation in Britain called Common Purpose created in the late 1980s by Julia Middleton who would work in the office of Deputy Prime Minister John Prescott during the long and disastrous premiership of war criminal Tony Blair. When Blair speaks the Cult is speaking and the man should have been in jail a long time ago. Common Purpose proclaims itself to be one of the biggest 'leadership development' organisations in the world while functioning as a *charity* with all the financial benefits which come from that. It hosts 'leadership development' courses and programmes all over the world and claims to have 'brought together' what it calls 'leaders' from more than 100 countries on six continents. The modus operandi of Common Purpose can be compared with the work of the UK government's reframing network that includes the Behavioural Insights Team 'nudge unit' and 'Covid' reframing specialists at SPI-B. WikiLeaks described Common Purpose long ago as 'a hidden virus in our government and schools' which is unknown to the general public: 'It recruits and trains "leaders" to be loyal to the directives of Common Purpose and the EU, instead of to their own departments, which they then undermine or subvert, the NHS [National Health Service] being an example.' This is a vital point to understand the 'Covid' hoax. The NHS, and its equivalent around the world, has been utterly reframed in terms of administrators and much of the medical personnel with the transformation underpinned by recruitment policies. The outcome has been the criminal and psychopathic behaviour of the

NHS over 'Covid' and we have seen the same in every other major country. WikiLeaks said Common Purpose trainees are 'learning to rule without regard to democracy' and to usher in a police state (current events explained). Common Purpose operated like a 'glue' and had members in the NHS, BBC, police, legal profession, church, many of Britain's 7,000 quangos, local councils, the Civil Service, government ministries and Parliament, and controlled many RDA's (Regional Development Agencies). Here we have one answer for how and why British institutions and their like in other countries have changed so negatively in relation to the public. This further explains how and why the beyond-disgraceful reframed BBC has become a propaganda arm of 'Covid' fascism. They are all part of a network pursuing the same goal.

By 2019 Common Purpose was quoting a figure of 85,000 'leaders' that had attended its programmes. These 'students' of all ages are known as Common Purpose 'graduates' and they consist of government, state and local government officials and administrators, police chiefs and officers, and a whole range of others operating within the national, local and global establishment. Cressida Dick, Commissioner of the London Metropolitan Police, is the Common Purpose graduate who was the 'Gold Commander' that oversaw what can only be described as the murder of Brazilian electrician Jean Charles de Menezes in 2005. He was held down by psychopathic police and shot seven times in the head by a psychopathic lunatic after being mistaken for a terrorist when he was just a bloke going about his day. Dick authorised officers to pursue and keep surveillance on de Menezes and ordered that he be stopped from entering the underground train system. Police psychopaths took her at her word clearly. She was 'disciplined' for this outrage by being *promoted* – eventually to the top of the 'Met' police where she has been a disaster. Many Chief Constables controlling the police in different parts of the UK are and have been Common Purpose graduates. I have heard the 'graduate' network described as a sort of Mafia or secret society operating within the fabric of government at all levels pursuing a collective policy



ingrained at Common Purpose training events. Founder Julia Middleton herself has said:

Locally and internationally, Common Purpose graduates will be 'lighting small fires' to create change in their organisations and communities ... The Common Purpose effect is best illustrated by the many stories of small changes brought about by leaders, who themselves have changed.

A Common Purpose mission statement declared:

Common Purpose aims to improve the way society works by expanding the vision, decision-making ability and influence of all kinds of leaders. The organisation runs a variety of educational programmes for leaders of all ages, backgrounds and sectors, in order to provide them with the inspirational, information and opportunities they need to change the world.

Yes, but into what? Since 2020 the answer has become clear.

## **NLP and the Delphi technique**

Common Purpose would seem to be a perfect name or would common programming be better? One of the foundation methods of reaching 'consensus' (group think) is by setting the agenda theme and then encouraging, cajoling or pressuring everyone to agree a 'consensus' in line with the core theme promoted by Common Purpose. The methodology involves the 'Delphi technique', or an adaptation of it, in which opinions are expressed that are summarised by a 'facilitator or change agent' at each stage. Participants are 'encouraged' to modify their views in the light of what others have said. Stage by stage the former individual opinions are merged into group consensus which just happens to be what Common Purpose wants them to believe. A key part of this is to marginalise anyone refusing to concede to group think and turn the group against them to apply pressure to conform. We are seeing this very technique used on the general population to make 'Covid' group-thinkers hostile to those who have seen through the bullshit. People can be reframed by using perception manipulation methods such as Neuro-Linguistic Programming (NLP) in which you change perception with the use of

carefully constructed language. An NLP website described the technique this way:

... A method of influencing brain behaviour (the 'neuro' part of the phrase) through the use of language (the 'linguistic' part) and other types of communication to enable a person to 'recode' the way the brain responds to stimuli (that's the 'programming') and manifest new and better behaviours. Neuro-Linguistic Programming often incorporates hypnosis and self-hypnosis to help achieve the change (or 'programming') that is wanted.

British alternative media operation UKColumn has done very detailed research into Common Purpose over a long period. I quoted co-founder and former naval officer Brian Gerrish in my book *Remember Who You Are*, published in 2011, as saying the following years before current times:

It is interesting that many of the mothers who have had children taken by the State speak of the Social Services people being icily cool, emotionless and, as two ladies said in slightly different words, '... like little robots'. We know that NLP is cumulative, so people can be given small imperceptible doses of NLP in a course here, another in a few months, next year etc. In this way, major changes are accrued in their personality, but the day by day change is almost unnoticeable.

In these and other ways 'graduates' have had their perceptions uniformly reframed and they return to their roles in the institutions of government, law enforcement, legal profession, military, 'education', the UK National Health Service and the whole swathe of the establishment structure to pursue a common agenda preparing for the 'post-industrial', 'post-democratic' society. I say 'preparing' but we are now there. 'Post-industrial' is code for the Great Reset and 'post-democratic' is 'Covid' fascism. UKColumn has spoken to partners of those who have attended Common Purpose 'training'. They have described how personalities and attitudes of 'graduates' changed very noticeably for the worse by the time they had completed the course. They had been 'reframed' and told they are the 'leaders' – the special ones – who know better than the population. There has also been the very demonstrable recruitment of psychopaths and narcissists into government administration at all

levels and law enforcement. If you want psychopathy hire psychopaths and you get a simple cause and effect. If you want administrators, police officers and 'leaders' to perceive the public as lesser beings who don't matter then employ narcissists. These personalities are identified using 'psychometrics' that identifies knowledge, abilities, attitudes and personality traits, mostly through carefully-designed questionnaires and tests. As this policy has passed through the decades we have had power-crazy, power-trippers appointed into law enforcement, security and government administration in preparation for current times and the dynamic between public and law enforcement/officialdom has been transformed. UKColumn's Brian Gerrish said of the narcissistic personality:

Their love of themselves and power automatically means that they will crush others who get in their way. I received a major piece of the puzzle when a friend pointed out that when they made public officials re-apply for their own jobs several years ago they were also required to do psychometric tests. This was undoubtedly the start of the screening process to get 'their' sort of people in post.

How obvious that has been since 2020 although it was clear what was happening long before if people paid attention to the changing public-establishment dynamic.

## **Change agents**

At the centre of events in 'Covid' Britain is the National Health Service (NHS) which has behaved disgracefully in slavishly following the Cult agenda. The NHS management structure is awash with Common Purpose graduates or 'change agents' working to a common cause. Helen Bevan, a Chief of Service Transformation at the NHS Institute for Innovation and Improvement, co-authored a document called 'Towards a million change agents, a review of the social movements literature: implications for large scale change in the NHS'. The document compared a project management approach to that of change and social movements where 'people change

themselves and each other – peer to peer’. Two definitions given for a ‘social movement’ were:

*A group of people who consciously attempt to build a radically new social order; involves people of a broad range of social backgrounds; and deploys politically confrontational and socially disruptive tactics – Cyrus Zirakzadeh 1997*

*Collective challenges, based on common purposes and social solidarities, in sustained interaction with elites, opponents, and authorities – Sidney Tarrow 1994*

Helen Bevan wrote another NHS document in which she defined ‘framing’ as ‘the process by which leaders construct, articulate and put across their message in a powerful and compelling way in order to win people to their cause and call them to action’. I think I could come up with another definition that would be rather more accurate. The National Health Service and institutions of Britain and the wider world have been taken over by reframed ‘change agents’ and that includes everything from the United Nations to national governments, local councils and social services which have been kidnapping children from loving parents on an extraordinary and gathering scale on the road to the end of parenthood altogether. Children from loving homes are stolen and kidnapped by the state and put into the ‘care’ (inversion) of the local authority through council homes, foster parents and forced adoption. At the same time children are allowed to be abused without response while many are under council ‘care’. UKColumn highlighted the Common Purpose connection between South Yorkshire Police and Rotherham council officers in the case of the scandal in that area of the sexual exploitation of children to which the authorities turned not one blind eye, but both:

We were alarmed to discover that the Chief Executive, the Strategic Director of Children and Young People's Services, the Manager for the Local Strategic Partnership, the Community Cohesion Manager, the Cabinet Member for Cohesion, the Chief Constable and his predecessor had all attended Leadership training courses provided by the pseudo-charity Common Purpose.

Once 'change agents' have secured positions of hire and fire within any organisation things start to move very quickly. Personnel are then hired and fired on the basis of whether they will work towards the agenda the change agent represents. If they do they are rapidly promoted even though they may be incompetent. Those more qualified and skilled who are pre-Common Purpose 'old school' see their careers stall and even disappear. This has been happening for decades in every institution of state, police, 'health' and social services and all of them have been transformed as a result in their attitudes to their jobs and the public. Medical professions, including nursing, which were once vocations for the caring now employ many cold, callous and couldn't give a shit personality types. The UKColumn investigation concluded:

By blurring the boundaries between people, professions, public and private sectors, responsibility and accountability, Common Purpose encourages 'graduates' to believe that as new selected leaders, they can work together, outside of the established political and social structures, to achieve a paradigm shift or CHANGE – so called 'Leading Beyond Authority'. In doing so, the allegiance of the individual becomes 'reframed' on CP colleagues and their NETWORK.

## **Reframing the Face-Nappies**

Nowhere has this process been more obvious than in the police where recruitment of psychopaths and development of unquestioning mind-controlled group-thinkers have transformed law enforcement into a politically-correct 'Woke' joke and a travesty of what should be public service. Today they wear their face-nappies like good little gofers and enforce 'Covid' rules which are fascism under another name. Alongside the specifically-recruited psychopaths we have software minds incapable of free thought. Brian Gerrish again:

An example is the policeman who would not get on a bike for a press photo because he had not done the cycling proficiency course. Normal people say this is political correctness gone mad. Nothing could be further from the truth. The policeman has been reframed, and in his reality it is perfect common sense not to get on the bike 'because he hasn't done the cycling course'.

Another example of this is where the police would not rescue a boy from a pond until they had taken advice from above on the 'risk assessment'. A normal person would have arrived, perhaps thought of the risk for a moment, and dived in. To the police now 'reframed', they followed 'normal' procedure.

There are shocking cases of reframed ambulance crews doing the same. Sheer unthinking stupidity of London Face-Nappies headed by Common Purpose graduate Cressida Dick can be seen in their behaviour at a vigil in March, 2021, for a murdered woman, Sarah Everard. A police officer had been charged with the crime. Anyone with a brain would have left the vigil alone in the circumstances. Instead they 'manhandled' women to stop them breaking 'Covid rules' to betray classic reframing. Minds in the thrall of perception control have no capacity for seeing a situation on its merits and acting accordingly. 'Rules is rules' is their only mind-set. My father used to say that rules and regulations are for the guidance of the intelligent and the blind obedience of the idiot. Most of the intelligent, decent, coppers have gone leaving only the other kind and a few old school for whom the job must be a daily nightmare. The combination of psychopaths and rule-book software minds has been clearly on public display in the 'Covid' era with automaton robots in uniform imposing fascistic 'Covid' regulations on the population without any personal initiative or judging situations on their merits. There are thousands of examples around the world, but I'll make my point with the infamous Derbyshire police in the English East Midlands – the ones who think pouring dye into beauty spots and using drones to track people walking in the countryside away from anyone is called 'policing'. To them there are rules decreed by the government which they have to enforce and in their bewildered state a group gathering in a closed space and someone walking alone in the countryside are the same thing. It is beyond idiocy and enters the realm of clinical insanity.

Police officers in Derbyshire said they were 'horrified' – *horrified* – to find 15 to 20 'irresponsible' kids playing a football match at a closed leisure centre 'in breach of coronavirus restrictions'. When they saw the police the kids ran away leaving their belongings behind and the reframed men and women of Derbyshire police were seeking to establish their identities with a view to fining their parents. The most natural thing for youngsters to do – kicking a ball about – is turned into a criminal activity and enforced by the moronic software programs of Derbyshire police. You find the same mentality in every country. These barely conscious 'horrified' officers said they had to take action because 'we need to ensure these rules are being followed' and 'it is of the utmost importance that you ensure your children are following the rules and regulations for Covid-19'. Had any of them done ten seconds of research to see if this parroting of their masters' script could be supported by any evidence? Nope. Reframed people don't think – others think for them and that's the whole idea of reframing. I have seen police officers one after the other repeating without question word for word what officialdom tells them just as I have seen great swathes of the public doing the same. Ask either for 'their' opinion and out spews what they have been told to think by the official narrative. Police and public may seem to be in different groups, but their mentality is the same. Most people do whatever they are told in fear not doing so or because they believe what officialdom tells them; almost the entirety of the police do what they are told for the same reason. Ultimately it's the tiny inner core of the global Cult that's telling both what to do.

So Derbyshire police were 'horrified'. Oh, really? Why did they think those kids were playing football? It was to relieve the psychological consequences of lockdown and being denied human contact with their friends and interaction, touch and discourse vital to human psychological health. Being denied this month after month has dismantled the psyche of many children and young people as depression and suicide have exploded. Were Derbyshire police *horrified by that*? Are you kidding? Reframed people don't have those

mental and emotional processes that can see how the impact on the psychological health of youngsters is far more dangerous than any 'virus' even if you take the mendacious official figures to be true. The reframed are told (programmed) how to act and so they do. The Derbyshire Chief Constable in the first period of lockdown when the black dye and drones nonsense was going on was Peter Goodman. He was the man who severed the connection between his force and the Derbyshire Constabulary *Male Voice* Choir when he decided that it was not inclusive enough to allow women to join. The fact it was a male voice choir making a particular sound produced by male voices seemed to elude a guy who terrifyingly ran policing in Derbyshire. He retired weeks after his force was condemned as disgraceful by former Supreme Court Justice Jonathan Sumption for their behaviour over extreme lockdown impositions. Goodman was replaced by his deputy Rachel Swann who was in charge when her officers were 'horrified'. The police statement over the boys committing the hanging-offence of playing football included the line about the youngsters being 'irresponsible in the times we are all living through' missing the point that the real relevance of the 'times we are all living through' is the imposition of fascism enforced by psychopaths and reframed minds of police officers playing such a vital part in establishing the fascist tyranny that their own children and grandchildren will have to live in their entire lives. As a definition of insanity that is hard to beat although it might be run close by imposing masks on people that can have a serious effect on their health while wearing a face nappy all day themselves. Once again public and police do it for the same reason – the authorities tell them to and who are they to have the self-respect to say no?

## **Workers in uniform**

How reframed do you have to be to arrest a *six-year-old* and take him to court for *picking a flower* while waiting for a bus? Brain dead police and officialdom did just that in North Carolina where criminal proceedings happen regularly for children under nine. Attorney Julie Boyer gave the six-year-old crayons and a colouring book



during the 'flower' hearing while the 'adults' decided his fate. County Chief District Court Judge Jay Corpening asked: 'Should a child that believes in Santa Claus, the Easter Bunny and the tooth fairy be making life-altering decisions?' Well, of course not, but common sense has no meaning when you have a common purpose and a reframed mind. Treating children in this way, and police operating in American schools, is all part of the psychological preparation for children to accept a police state as normal all their adult lives. The same goes for all the cameras and biometric tracking technology in schools. Police training is focused on reframing them as snowflake Wokers and this is happening in the military. Pentagon top brass said that 'training sessions on extremism' were needed for troops who asked why they were so focused on the Capitol Building riot when Black Lives Matter riots were ignored. What's the difference between them some apparently and rightly asked. Actually, there is a difference. Five people died in the Capitol riot, only one through violence, and that was a police officer shooting an unarmed protestor. BLM riots killed at least 25 people and cost billions. Asking the question prompted the psychopaths and reframed minds that run the Pentagon to say that more 'education' (programming) was needed. Troop training is all based on psychological programming to make them fodder for the Cult – 'Military men are just dumb, stupid animals to be used as pawns in foreign policy' as Cult-to-his-DNA former Secretary of State Henry Kissinger famously said. Governments see the police in similar terms and it's time for those among them who can see this to defend the people and stop being enforcers of the Cult agenda upon the people.

The US military, like the country itself, is being targeted for destruction through a long list of Woke impositions. Cult-owned gaga 'President' Biden signed an executive order when he took office to allow taxpayer money to pay for transgender surgery for active military personnel and veterans. Are you a man soldier? No, I'm a LGBTQIA+ with a hint of Skoliosexual and Spectrasexual. Oh, good man. Bad choice of words you bigot. The Pentagon announced in March, 2021, the appointment of the first 'diversity and inclusion

officer' for US Special Forces. Richard Torres-Estrada arrived with the publication of a 'D&I Strategic Plan which will guide the enterprise-wide effort to institutionalize and sustain D&I'. If you think a Special Forces 'Strategic Plan' should have something to do with defending America you haven't been paying attention. Defending Woke is now the military's new role. Torres-Estrada has posted images comparing Donald Trump with Adolf Hitler and we can expect no bias from him as a representative of the supposedly non-political Pentagon. Cable news host Tucker Carlson said: 'The Pentagon is now the Yale faculty lounge but with cruise missiles.' Meanwhile Secretary of Defense Lloyd Austin, a board member of weapons-maker Raytheon with stock and compensation interests in October, 2020, worth \$1.4 million, said he was purging the military of the 'enemy within' – anyone who isn't Woke and supports Donald Trump. Austin refers to his targets as 'racist extremists' while in true Woke fashion being himself a racist extremist. Pentagon documents pledge to 'eradicate, eliminate and conquer all forms of racism, sexism and homophobia'. The definitions of these are decided by 'diversity and inclusion committees' peopled by those who see racism, sexism and homophobia in every situation and opinion. Woke (the Cult) is dismantling the US military and purging testosterone as China expands its military and gives its troops 'masculinity training'. How do we think that is going to end when this is all Cult coordinated? The US military, like the British military, is controlled by Woke and spineless top brass who just go along with it out of personal career interests.

### **'Woke' means fast asleep**

Mind control and perception manipulation techniques used on individuals to create group-think have been unleashed on the global population in general. As a result many have no capacity to see the obvious fascist agenda being installed all around them or what 'Covid' is really all about. Their brains are firewalled like a computer system not to process certain concepts, thoughts and realisations that are bad for the Cult. The young are most targeted as the adults they

will be when the whole fascist global state is planned to be fully implemented. They need to be prepared for total compliance to eliminate all pushback from entire generations. The Cult has been pouring billions into taking complete control of 'education' from schools to universities via its operatives and corporations and not least Bill Gates as always. The plan has been to transform 'education' institutions into programming centres for the mentality of 'Woke'. James McConnell, professor of psychology at the University of Michigan, wrote in *Psychology Today* in 1970:

The day has come when we can combine sensory deprivation with drugs, hypnosis, and astute manipulation of reward and punishment, to gain almost absolute control over an individual's behaviour. It should then be possible to achieve a very rapid and highly effective type of brainwashing that would allow us to make dramatic changes in a person's behaviour and personality ...

... We should reshape society so that we all would be trained from birth to want to do what society wants us to do. We have the techniques to do it... no-one owns his own personality you acquired, and there's no reason to believe you should have the right to refuse to acquire a new personality if your old one is anti-social.

This was the potential for mass brainwashing in 1970 and the mentality there displayed captures the arrogant psychopathy that drives it forward. I emphasise that not all young people have succumbed to Woke programming and those that haven't are incredibly impressive people given that today's young are the most perceptually-targeted generations in history with all the technology now involved. Vast swathes of the young generations, however, have fallen into the spell – and that's what it is – of Woke. The Woke mentality and perceptual program is founded on *inversion* and you will appreciate later why that is so significant. Everything with Woke is inverted and the opposite of what it is claimed to be. Woke was a term used in African-American culture from the 1900s and referred to an awareness of social and racial justice. This is not the meaning of the modern version or 'New Woke' as I call it in *The Answer*. Oh, no, Woke today means something very different no matter how much Wokers may seek to hide that and insist Old Woke and New

Woke are the same. See if you find any 'awareness of social justice' here in the modern variety:

- Woke demands 'inclusivity' while excluding anyone with a different opinion and calls for mass censorship to silence other views.
- Woke claims to stand against oppression when imposing oppression is the foundation of all that it does. It is the driver of political correctness which is nothing more than a Cult invention to manipulate the population to silence itself.
- Woke believes itself to be 'liberal' while pursuing a global society that can only be described as fascist (see 'anti-fascist' fascist Antifa).
- Woke calls for 'social justice' while spreading injustice wherever it goes against the common 'enemy' which can be easily identified as a differing view.
- Woke is supposed to be a metaphor for 'awake' when it is solid-gold asleep and deep in a Cult-induced coma that meets the criteria for 'off with the fairies'.

I state these points as obvious facts if people only care to look. I don't do this with a sense of condemnation. We need to appreciate that the onslaught of perceptual programming on the young has been incessant and merciless. I can understand why so many have been reframed, or, given their youth, framed from the start to see the world as the Cult demands. The Cult has had access to their minds day after day in its 'education' system for their entire formative years. Perception is formed from information received and the Cult-created system is a life-long download of information delivered to elicit a particular perception, thus behaviour. The more this has expanded into still new extremes in recent decades and ever-increasing censorship has deleted other opinions and information why wouldn't that lead to a perceptual reframing on a mass scale? I

have described already cradle-to-grave programming and in more recent times the targeting of young minds from birth to adulthood has entered the stratosphere. This has taken the form of skewing what is 'taught' to fit the Cult agenda and the omnipresent techniques of group-think to isolate non-believers and pressure them into line. There has always been a tendency to follow the herd, but we really are in a new world now in relation to that. We have parents who can see the 'Covid' hoax told by their children not to stop them wearing masks at school, being 'Covid' tested or having the 'vaccine' in fear of the peer-pressure consequences of being different. What is 'peer-pressure' if not pressure to conform to group-think? Renegade Minds never group-think and always retain a set of perceptions that are unique to them. Group-think is always underpinned by consequences for not group-thinking. Abuse now aimed at those refusing DNA-manipulating 'Covid vaccines' are a potent example of this. The biggest pressure to conform comes from the very group which is itself being manipulated. 'I am programmed to be part of a hive mind and so you must be.'

Woke control structures in 'education' now apply to every mainstream organisation. Those at the top of the 'education' hierarchy (the Cult) decide the policy. This is imposed on governments through the Cult network; governments impose it on schools, colleges and universities; their leadership impose the policy on teachers and academics and they impose it on children and students. At any level where there is resistance, perhaps from a teacher or university lecturer, they are targeted by the authorities and often fired. Students themselves regularly demand the dismissal of academics (increasingly few) at odds with the narrative that the students have been programmed to believe in. It is quite a thought that students who are being targeted by the Cult become so consumed by programmed group-think that they launch protests and demand the removal of those who are trying to push back against those targeting the students. Such is the scale of perceptual inversion. We see this with 'Covid' programming as the Cult imposes the rules via psycho-psychologists and governments on

shops, transport companies and businesses which impose them on their staff who impose them on their customers who pressure Pushbackers to conform to the will of the Cult which is in the process of destroying them and their families. Scan all aspects of society and you will see the same sequence every time.

### **Fact free Woke and hijacking the 'left'**

There is no more potent example of this than 'Woke', a mentality only made possible by the deletion of factual evidence by an 'education' system seeking to produce an ever more uniform society. Why would you bother with facts when you don't know any? Deletion of credible history both in volume and type is highly relevant. Orwell said: 'Who controls the past controls the future: who controls the present controls the past.' They who control the perception of the past control the perception of the future and they who control the present control the perception of the past through the writing and deleting of history. Why would you oppose the imposition of Marxism in the name of Wokeism when you don't know that Marxism cost at least 100 million lives in the 20th century alone? Watch videos and read reports in which Woker generations are asked basic historical questions – it's mind-blowing. A survey of 2,000 people found that six percent of millennials (born approximately early 1980s to early 2000s) believed the Second World War (1939-1945) broke out with the assassination of President Kennedy (in 1963) and one in ten thought Margaret Thatcher was British Prime Minister at the time. She was in office between 1979 and 1990. We are in a post-fact society. Provable facts are no defence against the fascism of political correctness or Silicon Valley censorship. Facts don't matter anymore as we have witnessed with the 'Covid' hoax. Sacrificing uniqueness to the Woke group-think religion is all you are required to do and that means thinking for yourself is the biggest Woke no, no. All religions are an expression of group-think and censorship and Woke is just another religion with an orthodoxy defended by group-think and censorship. Burned at

the stake becomes burned on Twitter which leads back eventually to burned at the stake as Woke humanity regresses to ages past.

The biggest Woke inversion of all is its creators and funders. I grew up in a traditional left of centre political household on a council estate in Leicester in the 1950s and 60s – you know, the left that challenged the power of wealth-hoarding elites and threats to freedom of speech and opinion. In those days students went on marches defending freedom of speech while today's Wokers march for its deletion. What on earth could have happened? Those very elites (collectively the Cult) that we opposed in my youth and early life have funded into existence the antithesis of that former left and hijacked the 'brand' while inverting everything it ever stood for. We have a mentality that calls itself 'liberal' and 'progressive' while acting like fascists. Cult billionaires and their corporations have funded themselves into control of 'education' to ensure that Woke programming is unceasing throughout the formative years of children and young people and that non-Wokers are isolated (that word again) whether they be students, teachers or college professors. The Cult has funded into existence the now colossal global network of Woke organisations that have spawned and promoted all the 'causes' on the Cult wish-list for global transformation and turned Wokers into demanders of them. Does anyone really think it's a coincidence that the Cult agenda for humanity is a carbon (sorry) copy of the societal transformations desired by Woke?? These are only some of them:

**Political correctness:** The means by which the Cult deletes all public debates that it knows it cannot win if we had the free-flow of information and evidence.

**Human-caused 'climate change':** The means by which the Cult seeks to transform society into a globally-controlled dictatorship imposing its will over the fine detail of everyone's lives 'to save the planet' which doesn't actually need saving.

**Transgender obsession:** Preparing collective perception to accept the 'new human' which would not have genders because it would be created technologically and not through procreation. I'll have much more on this in Human 2.0.

**Race obsession:** The means by which the Cult seeks to divide and rule the population by triggering racial division through the perception that society is more racist than ever when the opposite is the case. Is it perfect in that regard? No. But to compare today with the racism of apartheid and segregation brought to an end by the civil rights movement in the 1960s is to insult the memory of that movement and inspirations like Martin Luther King. Why is the 'anti-racism' industry (which it is) so dominated by privileged white people?

**White supremacy:** This is a label used by privileged white people to demonise poor and deprived white people pushing back on tyranny to marginalise and destroy them. White people are being especially targeted as the dominant race by number within Western society which the Cult seeks to transform in its image. If you want to change a society you must weaken and undermine its biggest group and once you have done that by using the other groups you next turn on them to do the same ... 'Then they came for the Jews and I was not a Jew so I did nothing.'

**Mass migration:** The mass movement of people from the Middle East, Africa and Asia into Europe, from the south into the United States and from Asia into Australia are another way the Cult seeks to dilute the racial, cultural and political influence of white people on Western society. White people ask why their governments appear to be working against them while being politically and culturally biased towards incoming cultures. Well, here's your answer. In the same way sexually 'straight' people, men and women, ask why the



authorities are biased against them in favour of other sexualities. The answer is the same – that's the way the Cult wants it to be for very sinister motives.

These are all central parts of the Cult agenda and central parts of the Woke agenda and Woke was created and continues to be funded to an immense degree by Cult billionaires and corporations. If anyone begins to say 'coincidence' the syllables should stick in their throat.

### **Billionaire 'social justice warriors'**

Joe Biden is a 100 percent-owned asset of the Cult and the Wokers' man in the White House whenever he can remember his name and for however long he lasts with his rapidly diminishing cognitive function. Even walking up the steps of an aircraft without falling on his arse would appear to be a challenge. He's not an empty-shell puppet or anything. From the minute Biden took office (or the Cult did) he began his executive orders promoting the Woke wish-list. You will see the Woke agenda imposed ever more severely because it's really the *Cult* agenda. Woke organisations and activist networks spawned by the Cult are funded to the extreme so long as they promote what the Cult wants to happen. Woke is funded to promote 'social justice' by billionaires who become billionaires by destroying social justice. The social justice mantra is only a cover for dismantling social justice and funded by billionaires that couldn't give a damn about social justice. Everything makes sense when you see that. One of Woke's premier funders is Cult billionaire financier George Soros who said: 'I am basically there to make money, I cannot and do not look at the social consequences of what I do.' This is the same Soros who has given more than \$32 billion to his Open Society Foundations global Woke network and funded Black Lives Matter, mass immigration into Europe and the United States, transgender activism, climate change activism, political correctness and groups targeting 'white supremacy' in the form of privileged white thugs that dominate Antifa. What a scam it all is and when

you are dealing with the unquestioning fact-free zone of Woke scamming them is child's play. All you need to pull it off in all these organisations are a few in-the-know agents of the Cult and an army of naïve, reframed, uninformed, narcissistic, know-nothings convinced of their own self-righteousness, self-purity and virtue.

Soros and fellow billionaires and billionaire corporations have poured hundreds of millions into Black Lives Matter and connected groups and promoted them to a global audience. None of this is motivated by caring about black people. These are the billionaires that have controlled and exploited a system that leaves millions of black people in abject poverty and deprivation which they do absolutely nothing to address. The same Cult networks funding BLM were behind the *slave trade*! Black Lives Matter hijacked a phrase that few would challenge and they have turned this laudable concept into a political weapon to divide society. You know that BLM is a fraud when it claims that *All Lives Matter*, the most inclusive statement of all, is 'racist'. BLM and its Cult masters don't want to end racism. To them it's a means to an end to control all of humanity never mind the colour, creed, culture or background. What has destroying the nuclear family got to do with ending racism? Nothing – but that is one of the goals of BLM and also happens to be a goal of the Cult as I have been exposing in my books for decades. Stealing children from loving parents and giving schools ever more power to override parents is part of that same agenda. BLM is a Marxist organisation and why would that not be the case when the Cult created Marxism *and* BLM? Patrisse Cullors, a BLM co-founder, said in a 2015 video that she and her fellow organisers, including co-founder Alicia Garza, are 'trained Marxists'. The lady known after marriage as Patrisse Khan-Cullors bought a \$1.4 million home in 2021 in one of the whitest areas of California with a black population of just 1.6 per cent and has so far bought *four* high-end homes for a total of \$3.2 million. How very Marxist. There must be a bit of spare in the BLM coffers, however, when Cult corporations and billionaires have handed over the best part of \$100 million. Many black people can see that Black Lives Matter is not

working for them, but against them, and this is still more confirmation. Black journalist Jason Whitlock, who had his account suspended by Twitter for simply linking to the story about the 'Marxist's' home buying spree, said that BLM leaders are 'making millions of dollars off the backs of these dead black men who they wouldn't spit on if they were on fire and alive'.

## **Black Lies Matter**

Cult assets and agencies came together to promote BLM in the wake of the death of career criminal George Floyd who had been jailed a number of times including for forcing his way into the home of a black woman with others in a raid in which a gun was pointed at her stomach. Floyd was filmed being held in a Minneapolis street in 2020 with the knee of a police officer on his neck and he subsequently died. It was an appalling thing for the officer to do, but the same technique has been used by police on peaceful protestors of lockdown without any outcry from the Woke brigade. As unquestioning supporters of the Cult agenda Wokers have supported lockdown and all the 'Covid' claptrap while attacking anyone standing up to the tyranny imposed in its name. Court documents would later include details of an autopsy on Floyd by County Medical Examiner Dr Andrew Baker who concluded that Floyd had taken a fatal level of the drug fentanyl. None of this mattered to fact-free, question-free, Woke. Floyd's death was followed by worldwide protests against police brutality amid calls to defund the police. Throwing babies out with the bathwater is a Woke speciality. In the wake of the murder of British woman Sarah Everard a Green Party member of the House of Lords, Baroness Jones of Moulscroomb (Nincompoopia would have been better), called for a 6pm curfew for all men. This would be in breach of the Geneva Conventions on war crimes which ban collective punishment, but that would never have crossed the black and white Woke mind of Baroness Nincompoopia who would have been far too convinced of her own self-righteousness to compute such details. Many American cities did defund the police in the face of Floyd riots

and after \$15 million was deleted from the police budget in Washington DC under useless Woke mayor Muriel Bowser car-jacking alone rose by 300 percent and within six months the US capital recorded its highest murder rate in 15 years. The same happened in Chicago and other cities in line with the Cult/Soros plan to bring fear to streets and neighbourhoods by reducing the police, releasing violent criminals and not prosecuting crime. This is the mob-rule agenda that I have warned in the books was coming for so long. Shootings in the area of Minneapolis where Floyd was arrested increased by 2,500 percent compared with the year before. Defunding the police over George Floyd has led to a big increase in dead people with many of them black. Police protection for politicians making these decisions stayed the same or increased as you would expect from professional hypocrites. The Cult doesn't actually want to abolish the police. It wants to abolish local control over the police and hand it to federal government as the psychopaths advance the Hunger Games Society. Many George Floyd protests turned into violent riots with black stores and businesses destroyed by fire and looting across America fuelled by Black Lives Matter. Woke doesn't do irony. If you want civil rights you must loot the liquor store and the supermarket and make off with a smart TV. It's the only way.

### **It's not a race war – it's a class war**

Black people are patronised by privileged blacks and whites alike and told they are victims of white supremacy. I find it extraordinary to watch privileged blacks supporting the very system and bloodline networks behind the slave trade and parroting the same Cult-serving manipulative crap of their privileged white, often billionaire, associates. It is indeed not a race war but a class war and colour is just a diversion. Black Senator Cory Booker and black Congresswoman Maxine Waters, more residents of Nincompoopia, personify this. Once you tell people they are victims of someone else you devalue both their own responsibility for their plight and the power they have to impact on their reality and experience. Instead

we have: 'You are only in your situation because of whitey – turn on them and everything will change.' It won't change. Nothing changes in our lives unless *we* change it. Crucial to that is never seeing yourself as a victim and always as the creator of your reality. Life is a simple sequence of choice and consequence. Make different choices and you create different consequences. *You* have to make those choices – not Black Lives Matter, the Woke Mafia and anyone else that seeks to dictate your life. Who are they these Wokers, an emotional and psychological road traffic accident, to tell you what to do? Personal empowerment is the last thing the Cult and its Black Lives Matter want black people or anyone else to have. They claim to be defending the underdog while *creating* and perpetuating the underdog. The Cult's worst nightmare is human unity and if they are going to keep blacks, whites and every other race under economic servitude and control then the focus must be diverted from what they have in common to what they can be manipulated to believe divides them. Blacks have to be told that their poverty and plight is the fault of the white bloke living on the street in the same poverty and with the same plight they are experiencing. The difference is that your plight black people is due to him, a white supremacist with 'white privilege' living on the street. Don't unite as one human family against your mutual oppressors and suppressors – fight the oppressor with the white face who is as financially deprived as you are. The Cult knows that as its 'Covid' agenda moves into still new levels of extremism people are going to respond and it has been spreading the seeds of disunity everywhere to stop a united response to the evil that targets *all of us*.

Racist attacks on 'whiteness' are getting ever more outrageous and especially through the American Democratic Party which has an appalling history for anti-black racism. Barack Obama, Joe Biden, Hillary Clinton and Nancy Pelosi all eulogised about Senator Robert Byrd at his funeral in 2010 after a nearly 60-year career in Congress. Byrd was a brutal Ku Klux Klan racist and a violent abuser of Cathy O'Brien in MKUltra. He said he would never fight in the military 'with a negro by my side' and 'rather I should die a thousand times,

and see Old Glory trampled in the dirt never to rise again, than to see this beloved land of ours become degraded by race mongrels, a throwback to the blackest specimen from the wilds'. Biden called Byrd a 'very close friend and mentor'. These 'Woke' hypocrites are not anti-racist they are anti-poor and anti-people not of their perceived class. Here is an illustration of the scale of anti-white racism to which we have now descended. Seriously Woke and moronic *New York Times* contributor Damon Young described whiteness as a 'virus' that 'like other viruses will not die until there are no bodies left for it to infect'. He went on: '... the only way to stop it is to locate it, isolate it, extract it, and kill it.' Young can say that as a black man with no consequences when a white man saying the same in reverse would be facing a jail sentence. *That's* racism. We had super-Woke numbskull senators Tammy Duckworth and Mazie Hirono saying they would object to future Biden Cabinet appointments if he did not nominate more Asian Americans and Pacific Islanders. Never mind the ability of the candidate what do they look like? Duckworth said: 'I will vote for racial minorities and I will vote for LGBTQ, but anyone else I'm not voting for.' Appointing people on the grounds of race is illegal, but that was not a problem for this ludicrous pair. They were on-message and that's a free pass in any situation.

## **Critical race racism**

White children are told at school they are intrinsically racist as they are taught the divisive 'critical race theory'. This claims that the law and legal institutions are inherently racist and that race is a socially constructed concept used by white people to further their economic and political interests at the expense of people of colour. White is a 'virus' as we've seen. Racial inequality results from 'social, economic, and legal differences that white people create between races to maintain white interests which leads to poverty and criminality in minority communities'. I must tell that to the white guy sleeping on the street. The principal of East Side Community School in New York sent white parents a manifesto that called on

them to become 'white traitors' and advocate for full 'white abolition'. These people are teaching your kids when they urgently need a psychiatrist. The 'school' included a chart with 'eight white identities' that ranged from 'white supremacist' to 'white abolition' and defined the behaviour white people must follow to end 'the regime of whiteness'. Woke blacks and their privileged white associates are acting exactly like the slave owners of old and Ku Klux Klan racists like Robert Byrd. They are too full of their own self-purity to see that, but it's true. Racism is not a body type; it's a state of mind that can manifest through any colour, creed or culture.

Another racial fraud is '*equity*'. Not equality of treatment and opportunity – equity. It's a term spun as equality when it means something very different. Equality in its true sense is a raising up while '*equity*' is a race to the bottom. Everyone in the same level of poverty is '*equity*'. Keep everyone down – that's equity. The Cult doesn't want anyone in the human family to be empowered and BLM leaders, like all these 'anti-racist' organisations, continue their privileged, pampered existence by perpetuating the perception of gathering racism. When is the last time you heard an 'anti-racist' or 'anti-Semitism' organisation say that acts of racism and discrimination have *fallen*? It's not in the interests of their fundraising and power to influence and the same goes for the professional soccer anti-racism operation, Kick It Out. Two things confirmed that the Black Lives Matter riots in the summer of 2020 were Cult creations. One was that while anti-lockdown protests were condemned in this same period for 'transmitting 'Covid' the authorities supported mass gatherings of Black Lives Matter supporters. I even saw self-deluding people claiming to be doctors say the two types of protest were not the same. No – the non-existent 'Covid' was in favour of lockdowns and attacked those that protested against them while 'Covid' supported Black Lives Matter and kept well away from its protests. The whole thing was a joke and as lockdown protestors were arrested, often brutally, by reframed Face-Nappies we had the grotesque sight of police officers taking the knee to Black Lives Matter, a Cult-funded Marxist

organisation that supports violent riots and wants to destroy the nuclear family and white people.

## **He's not white? Shucks!**

Woke obsession with race was on display again when ten people were shot dead in Boulder, Colorado, in March, 2021. Cult-owned Woke TV channels like CNN said the shooter appeared to be a white man and Wokers were on Twitter condemning 'violent white men' with the usual mantras. Then the shooter's name was released as Ahmad Al Aliwi Alissa, an anti-Trump Arab-American, and the sigh of disappointment could be heard five miles away. Never mind that ten people were dead and what that meant for their families. Race baiting was all that mattered to these sick Cult-serving people like Barack Obama who exploited the deaths to further divide America on racial grounds which is his job for the Cult. This is the man that 'racist' white Americans made the first black president of the United States and then gave him a second term. Not-very-bright Obama has become filthy rich on the back of that and today appears to have a big influence on the Biden administration. Even so he's still a downtrodden black man and a victim of white supremacy. This disingenuous fraud reveals the contempt he has for black people when he puts on a Deep South Alabama accent whenever he talks to them, no, *at* them.

Another BLM red flag was how the now fully-Woke (fully-Cult) and fully-virtue-signalled professional soccer authorities had their teams taking the knee before every match in support of Marxist Black Lives Matter. Soccer authorities and clubs displayed 'Black Lives Matter' on the players' shirts and flashed the name on electronic billboards around the pitch. Any fans that condemned what is a Freemasonic taking-the-knee ritual were widely condemned as you would expect from the Woke virtue-signallers of professional sport and the now fully-Woke media. We have reverse racism in which you are banned from criticising any race or culture except for white people for whom anything goes – say what you like, no problem. What has this got to do with racial harmony and



equality? We've had black supremacists from Black Lives Matter telling white people to fall to their knees in the street and apologise for their white supremacy. Black supremacists acting like white supremacist slave owners of the past couldn't breach their self-obsessed, race-obsessed sense of self-purity. Joe Biden appointed a race-obsessed black supremacist Kristen Clarke to head the Justice Department Civil Rights Division. Clarke claimed that blacks are endowed with 'greater mental, physical and spiritual abilities' than whites. If anyone reversed that statement they would be vilified. Clarke is on-message so no problem. She's never seen a black-white situation in which the black figure is anything but a virtuous victim and she heads the Civil Rights Division which should treat everyone the same or it isn't civil rights. Another perception of the Renegade Mind: If something or someone is part of the Cult agenda they will be supported by Woke governments and media no matter what. If they're not, they will be condemned and censored. It really is that simple and so racist Clarke prospers despite (make that because of) her racism.

## **The end of culture**

Biden's administration is full of such racial, cultural and economic bias as the Cult requires the human family to be divided into warring factions. We are now seeing racially-segregated graduations and everything, but everything, is defined through the lens of perceived 'racism'. We have 'racist' mathematics, 'racist' food and even 'racist' *plants*. World famous Kew Gardens in London said it was changing labels on plants and flowers to tell its pre-'Covid' more than two million visitors a year how racist they are. Kew director Richard Deverell said this was part of an effort to 'move quickly to decolonise collections' after they were approached by one Ajay Chhabra 'an actor with an insight into how sugar cane was linked to slavery'. They are *plants* you idiots. 'Decolonisation' in the Woke manual really means colonisation of society with its mentality and by extension colonisation by the Cult. We are witnessing a new Chinese-style 'Cultural Revolution' so essential to the success of all

Marxist takeovers. Our cultural past and traditions have to be swept away to allow a new culture to be built-back-better. Woke targeting of long-standing Western cultural pillars including historical monuments and cancelling of historical figures is what happened in the Mao revolution in China which 'purged remnants of capitalist and traditional elements from Chinese society' and installed Maoism as the dominant ideology'. For China see the Western world today and for 'dominant ideology' see Woke. Better still see Marxism or Maoism. The 'Covid' hoax has specifically sought to destroy the arts and all elements of Western culture from people meeting in a pub or restaurant to closing theatres, music venues, sports stadiums, places of worship and even banning *singing*. Destruction of Western society is also why criticism of any religion is banned except for Christianity which again is the dominant religion as white is the numerically-dominant race. Christianity may be fading rapidly, but its history and traditions are weaved through the fabric of Western society. Delete the pillars and other structures will follow until the whole thing collapses. I am not a Christian defending that religion when I say that. I have no religion. It's just a fact. To this end Christianity has itself been turned Woke to usher its own downfall and its ranks are awash with 'change agents' – knowing and unknowing – at every level including Pope Francis (*definitely* knowing) and the clueless Archbishop of Canterbury Justin Welby (possibly not, but who can be sure?). Woke seeks to coordinate attacks on Western culture, traditions, and ways of life through 'intersectionality' defined as 'the complex, cumulative way in which the effects of multiple forms of discrimination (such as racism, sexism, and classism) combine, overlap, or intersect especially in the experiences of marginalised individuals or groups'. Wade through the Orwellian Woke-speak and this means coordinating disparate groups in a common cause to overthrow freedom and liberal values.

The entire structure of public institutions has been infested with Woke – government at all levels, political parties, police, military, schools, universities, advertising, media and trade unions. This abomination has been achieved through the Cult web by appointing

Wokers to positions of power and battering non-Wokers into line through intimidation, isolation and threats to their job. Many have been fired in the wake of the empathy-deleted, vicious hostility of 'social justice' Wokers and the desire of gutless, spineless employers to virtue-signal their Wokeness. Corporations are filled with Wokers today, most notably those in Silicon Valley. Ironically at the top they are not Woke at all. They are only exploiting the mentality their Cult masters have created and funded to censor and enslave while the Wokers cheer them on until it's their turn. Thus the Woke 'liberal left' is an inversion of the traditional liberal left. Campaigning for justice on the grounds of power and wealth distribution has been replaced by campaigning for identity politics. The genuine traditional left would never have taken money from today's billionaire abusers of fairness and justice and nor would the billionaires have wanted to fund that genuine left. It would not have been in their interests to do so. The division of opinion in those days was between the haves and have nots. This all changed with Cult manipulated and funded identity politics. The division of opinion today is between Wokers and non-Wokers and not income brackets. Cult corporations and their billionaires may have taken wealth disparity to cataclysmic levels of injustice, but as long as they speak the language of Woke, hand out the dosh to the Woke network and censor the enemy they are 'one of us'. Billionaires who don't give a damn about injustice are laughing at them till their bellies hurt. Wokers are not even close to self-aware enough to see that. The transformed 'left' dynamic means that Wokers who drone on about 'social justice' are funded by billionaires that have destroyed social justice the world over. It's *why* they are billionaires.

## **The climate con**

Nothing encapsulates what I have said more comprehensively than the hoax of human-caused global warming. I have detailed in my books over the years how Cult operatives and organisations were the pump-primers from the start of the climate con. A purpose-built vehicle for this is the Club of Rome established by the Cult in 1968

with the Rockefellers and Rothschilds centrally involved all along. Their gofer frontman Maurice Strong, a Canadian oil millionaire, hosted the Earth Summit in Rio de Janeiro, Brazil, in 1992 where the global 'green movement' really expanded in earnest under the guiding hand of the Cult. The Earth Summit established Agenda 21 through the Cult-created-and-owned United Nations to use the illusion of human-caused climate change to justify the transformation of global society to save the world from climate disaster. It is a No-Problem-Reaction-Solution sold through governments, media, schools and universities as whole generations have been terrified into believing that the world was going to end in their lifetimes unless what old people had inflicted upon them was stopped by a complete restructuring of how everything is done. Chill, kids, it's all a hoax. Such restructuring is precisely what the Cult agenda demands (purely by coincidence of course). Today this has been given the codename of the Great Reset which is only an updated term for Agenda 21 and its associated Agenda 2030. The latter, too, is administered through the UN and was voted into being by the General Assembly in 2015. Both 21 and 2030 seek centralised control of all resources and food right down to the raindrops falling on your own land. These are some of the demands of Agenda 21 established in 1992. See if you recognise this society emerging today:

- End national sovereignty
- State planning and management of all land resources, ecosystems, deserts, forests, mountains, oceans and fresh water; agriculture; rural development; biotechnology; and ensuring 'equity'
- The state to 'define the role' of business and financial resources
- Abolition of private property
- 'Restructuring' the family unit (see BLM)
- Children raised by the state
- People told what their job will be
- Major restrictions on movement
- Creation of 'human settlement zones'

- Mass resettlement as people are forced to vacate land where they live
- Dumbing down education
- Mass global depopulation in pursuit of all the above

The United Nations was created as a Trojan horse for world government. With the climate con of critical importance to promoting that outcome you would expect the UN to be involved. Oh, it's involved all right. The UN is promoting Agenda 21 and Agenda 2030 justified by 'climate change' while also driving the climate hoax through its Intergovernmental Panel on Climate Change (IPCC), one of the world's most corrupt organisations. The IPCC has been lying ferociously and constantly since the day it opened its doors with the global media hanging unquestioningly on its every mendacious word. The Green movement is entirely Woke and has long lost its original environmental focus since it was co-opted by the Cult. An obsession with 'global warming' has deleted its values and scrambled its head. I experienced a small example of what I mean on a beautiful country walk that I have enjoyed several times a week for many years. The path merged into the fields and forests and you felt at one with the natural world. Then a 'Green' organisation, the Hampshire and Isle of Wight Wildlife Trust, took over part of the land and proceeded to cut down a large number of trees, including mature ones, to install a horrible big, bright steel 'this-is-ours-stay-out' fence that destroyed the whole atmosphere of this beautiful place. No one with a feel for nature would do that. Day after day I walked to the sound of chainsaws and a magnificent mature weeping willow tree that I so admired was cut down at the base of the trunk. When I challenged a Woke young girl in a green shirt (of course) about this vandalism she replied: 'It's a weeping willow – it will grow back.' This is what people are paying for when they donate to the Hampshire and Isle of Wight Wildlife Trust and many other 'green' organisations today. It is not the environmental movement that I knew and instead has become a support-system – as with Extinction Rebellion – for a very dark agenda.

## **Private jets for climate justice**

The Cult-owned, Gates-funded, World Economic Forum and its founder Klaus Schwab were behind the emergence of Greta Thunberg to harness the young behind the climate agenda and she was invited to speak to the world at ... the UN. Schwab published a book, *Covid-19: The Great Reset* in 2020 in which he used the 'Covid' hoax and the climate hoax to lay out a new society straight out of Agenda 21 and Agenda 2030. Bill Gates followed in early 2021 when he took time out from destroying the world to produce a book in his name about the way to save it. Gates flies across the world in private jets and admitted that 'I probably have one of the highest greenhouse gas footprints of anyone on the planet ... my personal flying alone is gigantic.' He has also bid for the planet's biggest private jet operator. Other climate change saviours who fly in private jets include John Kerry, the US Special Presidential Envoy for Climate, and actor Leonardo DiCaprio, a 'UN Messenger of Peace with special focus on climate change'. These people are so full of bullshit they could corner the market in manure. We mustn't be sceptical, though, because the Gates book, *How to Avoid a Climate Disaster: The Solutions We Have and the Breakthroughs We Need*, is a genuine attempt to protect the world and not an obvious pile of excrement attributed to a mega-psychopath aimed at selling his masters' plans for humanity. The Gates book and the other shite-pile by Klaus Schwab could have been written by the same person and may well have been. Both use 'climate change' and 'Covid' as the excuses for their new society and by coincidence the Cult's World Economic Forum and Bill and Melinda Gates Foundation promote the climate hoax and hosted Event 201 which pre-empted with a 'simulation' the very 'coronavirus' hoax that would be simulated for real on humanity within weeks. The British 'royal' family is promoting the 'Reset' as you would expect through Prince 'climate change caused the war in Syria' Charles and his hapless son Prince William who said that we must 'reset our relationship with nature and our trajectory as a species' to avoid a climate disaster. Amazing how many promoters of the 'Covid' and 'climate change' control

systems are connected to Gates and the World Economic Forum. A 'study' in early 2021 claimed that carbon dioxide emissions must fall by the equivalent of a global lockdown roughly every two years for the next decade to save the planet. The 'study' appeared in the same period that the Schwab mob claimed in a video that lockdowns destroying the lives of billions are good because they make the earth 'quieter' with less 'ambient noise'. They took down the video amid a public backlash for such arrogant, empathy-deleted stupidity You see, however, where they are going with this. Corinne Le Quéré, a professor at the Tyndall Centre for Climate Change Research, University of East Anglia, was lead author of the climate lockdown study, and she writes for ... the World Economic Forum. Gates calls in 'his' book for changing 'every aspect of the economy' (long-time Cult agenda) and for humans to eat synthetic 'meat' (predicted in my books) while cows and other farm animals are eliminated. Australian TV host and commentator Alan Jones described what carbon emission targets would mean for farm animals in Australia alone if emissions were reduced as demanded by 35 percent by 2030 and zero by 2050:

Well, let's take agriculture, the total emissions from agriculture are about 75 million tonnes of carbon dioxide, equivalent. Now reduce that by 35 percent and you have to come down to 50 million tonnes, I've done the maths. So if you take for example 1.5 million cows, you're going to have to reduce the herd by 525,000 [by] 2030, nine years, that's 58,000 cows a year. The beef herd's 30 million, reduce that by 35 percent, that's 10.5 million, which means 1.2 million cattle have to go every year between now and 2030. This is insanity!

There are 75 million sheep. Reduce that by 35 percent, that's 26 million sheep, that's almost 3 million a year. So under the Paris Agreement over 30 million beasts. dairy cows, cattle, pigs and sheep would go. More than 8,000 every minute of every hour for the next decade, do these people know what they're talking about?

Clearly they don't at the level of campaigners, politicians and administrators. The Cult *does* know; that's the outcome it wants. We are faced with not just a war on humanity. Animals and the natural world are being targeted and I have been saying since the 'Covid' hoax began that the plan eventually was to claim that the 'deadly virus' is able to jump from animals, including farm animals and

domestic pets, to humans. Just before this book went into production came this story: 'Russia registers world's first Covid-19 vaccine for cats & dogs as makers of Sputnik V warn pets & farm animals could spread virus'. The report said 'top scientists warned that the deadly pathogen could soon begin spreading through homes and farms' and 'the next stage is the infection of farm and domestic animals'. Know the outcome and you'll see the journey. Think what that would mean for animals and keep your eye on a term called zoonosis or zoonotic diseases which transmit between animals and humans. The Cult wants to break the connection between animals and people as it does between people and people. Farm animals fit with the Cult agenda to transform food from natural to synthetic.

### **The gas of life is killing us**

There can be few greater examples of Cult inversion than the condemnation of carbon dioxide as a dangerous pollutant when it is the gas of life. Without it the natural world would be dead and so we would all be dead. We breathe in oxygen and breathe out carbon dioxide while plants produce oxygen and absorb carbon dioxide. It is a perfect symbiotic relationship that the Cult wants to dismantle for reasons I will come to in the final two chapters. Gates, Schwab, other Cult operatives and mindless repeaters, want the world to be 'carbon neutral' by at least 2050 and the earlier the better. 'Zero carbon' is the cry echoed by lunatics calling for 'Zero Covid' when we already have it. These carbon emission targets will deindustrialise the world in accordance with Cult plans – the post-industrial, post-democratic society – and with so-called renewables like solar and wind not coming even close to meeting human energy needs blackouts and cold are inevitable. Texans got the picture in the winter of 2021 when a snow storm stopped wind turbines and solar panels from working and the lights went down along with water which relies on electricity for its supply system. Gates wants everything to be powered by electricity to ensure that his masters have the kill switch to stop all human activity, movement, cooking, water and warmth any time they like. The climate lie is so



stupendously inverted that it claims we must urgently reduce carbon dioxide when we *don't have enough*.

Co2 in the atmosphere is a little above 400 parts per million when the optimum for plant growth is 2,000 ppm and when it falls anywhere near 150 ppm the natural world starts to die and so do we. It fell to as low as 280 ppm in an 1880 measurement in Hawaii and rose to 413 ppm in 2019 with industrialisation which is why the planet has become *greener* in the industrial period. How insane then that psychopathic madman Gates is not satisfied only with blocking the rise of Co2. He's funding technology to suck it out of the atmosphere. The reason why will become clear. The industrial era is not destroying the world through Co2 and has instead turned around a potentially disastrous ongoing fall in Co2. Greenpeace co-founder and scientist Patrick Moore walked away from Greenpeace in 1986 and has exposed the green movement for fear-mongering and lies. He said that 500 million years ago there was *17 times* more Co2 in the atmosphere than we have today and levels have been falling for hundreds of millions of years. In the last 150 million years Co2 levels in Earth's atmosphere had reduced by *90 percent*. Moore said that by the time humanity began to unlock carbon dioxide from fossil fuels we were at '38 seconds to midnight' and in that sense: 'Humans are [the Earth's] salvation.' Moore made the point that only half the Co2 emitted by fossil fuels stays in the atmosphere and we should remember that all pollution pouring from chimneys that we are told is carbon dioxide is in fact nothing of the kind. It's pollution. Carbon dioxide is an invisible gas.

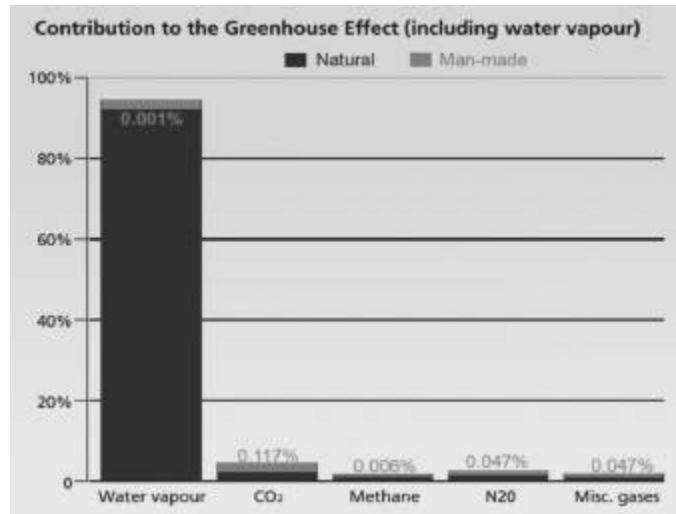
William Happer, Professor of Physics at Princeton University and long-time government adviser on climate, has emphasised the Co2 deficiency for maximum growth and food production. Greenhouse growers don't add carbon dioxide for a bit of fun. He said that most of the warming in the last 100 years, after the earth emerged from the super-cold period of the 'Little Ice Age' into a natural warming cycle, was over by 1940. Happer said that a peak year for warming in 1988 can be explained by a 'monster El Nino' which is a natural and cyclical warming of the Pacific that has nothing to do with 'climate

change'. He said the effect of Co2 could be compared to painting a wall with red paint in that once two or three coats have been applied it didn't matter how much more you slapped on because the wall will not get much redder. Almost all the effect of the rise in Co2 has already happened, he said, and the volume in the atmosphere would now have to *double* to increase temperature by a single degree. Climate hoaxers know this and they have invented the most ridiculously complicated series of 'feedback' loops to try to overcome this rather devastating fact. You hear puppet Greta going on cluelessly about feedback loops and this is why.

### **The Sun affects temperature? No you *climate denier***

Some other nonsense to contemplate: Climate graphs show that rises in temperature do not follow rises in Co2 – *it's the other way round* with a lag between the two of some 800 years. If we go back 800 years from present time we hit the Medieval Warm Period when temperatures were higher than now without any industrialisation and this was followed by the Little Ice Age when temperatures plummeted. The world was still emerging from these centuries of serious cold when many climate records began which makes the ever-repeated line of the 'hottest year since records began' meaningless when you are not comparing like with like. The coldest period of the Little Ice Age corresponded with the lowest period of sunspot activity when the Sun was at its least active. Proper scientists will not be at all surprised by this when it confirms the obvious fact that earth temperature is affected by the scale of Sun activity and the energetic power that it subsequently emits; but when is the last time you heard a climate hoaxer talking about the Sun as a source of earth temperature?? Everything has to be focussed on Co2 which makes up just 0.117 percent of so-called greenhouse gases and only a fraction of even that is generated by human activity. The rest is natural. More than *90 percent* of those greenhouse gases are water vapour and clouds ([Fig 9](#)). Ban moisture I say. Have you noticed that the climate hoaxers no longer use the polar bear as their promotion image? That's because far from becoming extinct polar

bear communities are stable or thriving. Joe Bastardi, American meteorologist, weather forecaster and outspoken critic of the climate lie, documents in his book *The Climate Chronicles* how weather patterns and events claimed to be evidence of climate change have been happening since long before industrialisation: 'What happened before naturally is happening again, as is to be expected given the cyclical nature of the climate due to the design of the planet.' If you read the detailed background to the climate hoax in my other books you will shake your head and wonder how anyone could believe the crap which has spawned a multi-trillion dollar industry based on absolute garbage (see HIV causes AIDs and Sars-Cov-2 causes 'Covid-19'). Climate and 'Covid' have much in common given they have the same source. They both have the contradictory *everything* factor in which everything is explained by reference to them. It's hot – 'it's climate change'. It's cold – 'it's climate change'. I got a sniffle – 'it's Covid'. I haven't got a sniffle – 'it's Covid'. Not having a sniffle has to be a symptom of 'Covid'. Everything is and not having a sniffle is especially dangerous if you are a slow walker. For sheer audacity I offer you a Cambridge University 'study' that actually linked 'Covid' to 'climate change'. It had to happen eventually. They concluded that climate change played a role in 'Covid-19' spreading from animals to humans because ... wait for it ... I kid you not ... *the two groups were forced closer together as populations grow*. Er, that's it. The whole foundation on which this depended was that 'Bats are the likely zoonotic origin of SARS-CoV-1 and SARS-CoV-2'. Well, they are not. They are nothing to do with it. Apart from bats not being the origin and therefore 'climate change' effects on bats being irrelevant I am in awe of their academic insight. Where would we be without them? Not where we are that's for sure.



**Figure 9:** The idea that the gas of life is disastrously changing the climate is an insult to brain cell activity.

One other point about the weather is that climate modification is now well advanced and not every major weather event is natural – or earthquake come to that. I cover this subject at some length in other books. China is openly planning a rapid expansion of its weather modification programme which includes changing the climate in an area more than one and a half times the size of India. China used weather manipulation to ensure clear skies during the 2008 Olympics in Beijing. I have quoted from US military documents detailing how to employ weather manipulation as a weapon of war and they did that in the 1960s and 70s during the conflict in Vietnam with Operation Popeye manipulating monsoon rains for military purposes. Why would there be international treaties on weather modification if it wasn't possible? Of course it is. Weather is energetic information and it can be changed.

### **How was the climate hoax pulled off? See 'Covid'**

If you can get billions to believe in a 'virus' that doesn't exist you can get them to believe in human-caused climate change that doesn't exist. Both are being used by the Cult to transform global society in the way it has long planned. Both hoaxes have been achieved in pretty much the same way. First you declare a lie is a fact. There's a

'virus' you call SARS-Cov-2 or humans are warming the planet with their behaviour. Next this becomes, via Cult networks, the foundation of government, academic and science policy and belief. Those who parrot the mantra are given big grants to produce research that confirms the narrative is true and ever more 'symptoms' are added to make the 'virus'/'climate change' sound even more scary. Scientists and researchers who challenge the narrative have their grants withdrawn and their careers destroyed. The media promote the lie as the unquestionable truth and censor those with an alternative view or evidence. A great percentage of the population believe what they are told as the lie becomes an everybody-knows-that and the believing-masses turn on those with a mind of their own. The technique has been used endlessly throughout human history. Wokers are the biggest promoters of the climate lie *and* 'Covid' fascism because their minds are owned by the Cult; their sense of self-righteous self-purity knows no bounds; and they exist in a bubble of reality in which facts are irrelevant and only get in the way of looking without seeing.

Running through all of this like veins in a blue cheese is control of information, which means control of perception, which means control of behaviour, which collectively means control of human society. The Cult owns the global media and Silicon Valley fascists for the simple reason that it *has* to. Without control of information it can't control perception and through that human society. Examine every facet of the Cult agenda and you will see that anything supporting its introduction is never censored while anything pushing back is always censored. I say again: Psychopaths that know why they are doing this must go before Nuremberg trials and those that follow their orders must trot along behind them into the same dock. 'I was just following orders' didn't work the first time and it must not work now. Nuremberg trials must be held all over the world before public juries for politicians, government officials, police, compliant doctors, scientists and virologists, and all Cult operatives such as Gates, Tedros, Fauci, Vallance, Whitty, Ferguson, Zuckerberg, Wojcicki, Brin, Page, Dorsey, the whole damn lot of

them – including, no *especially*, the psychopath psychologists. Without them and the brainless, gutless excuses for journalists that have repeated their lies, none of this could be happening. Nobody can be allowed to escape justice for the psychological and economic Armageddon they are all responsible for visiting upon the human race.

As for the compliant, unquestioning, swathes of humanity, and the self-obsessed, all-knowing ignorance of the Wokers ... don't start me. God help their kids. God help their grandkids. God *help them*.

## CHAPTER NINE

### **We must have it? So what is it?**

*Well I won't back down. No, I won't back down. You can stand me up at the Gates of Hell. But I won't back down*

**Tom Petty**

I will now focus on the genetically-manipulating 'Covid vaccines' which do not meet this official definition of a vaccine by the US Centers for Disease Control (CDC): 'A product that stimulates a person's immune system to produce immunity to a specific disease, protecting the person from that disease.' On that basis 'Covid vaccines' are not a vaccine in that the makers don't even claim they stop infection or transmission.

They are instead part of a multi-levelled conspiracy to change the nature of the human body and what it means to be 'human' and to depopulate an enormous swathe of humanity. What I shall call Human 1.0 is on the cusp of becoming Human 2.0 and for very sinister reasons. Before I get to the 'Covid vaccine' in detail here's some background to vaccines in general. Government regulators do not test vaccines – the makers do – and the makers control which data is revealed and which isn't. Children in America are given 50 vaccine doses by age six and 69 by age 19 and the effect of the whole combined schedule has never been tested. Autoimmune diseases when the immune system attacks its own body have soared in the mass vaccine era and so has disease in general in children and the young. Why wouldn't this be the case when vaccines target the *immune system*? The US government gave Big Pharma drug

companies immunity from prosecution for vaccine death and injury in the 1986 National Childhood Vaccine Injury Act (NCVIA) and since then the government (taxpayer) has been funding compensation for the consequences of Big Pharma vaccines. The criminal and satanic drug giants can't lose and the vaccine schedule has increased dramatically since 1986 for this reason. There is no incentive to make vaccines safe and a big incentive to make money by introducing ever more. Even against a ridiculously high bar to prove vaccine liability, and with the government controlling the hearing in which it is being challenged for compensation, the vaccine court has so far paid out more than \$4 billion. These are the vaccines we are told are safe and psychopaths like Zuckerberg censor posts saying otherwise. The immunity law was even justified by a ruling that vaccines by their nature were 'unavoidably unsafe'.

Check out the ingredients of vaccines and you will be shocked if you are new to this. *They put that in children's bodies?? What??* Try aluminium, a brain toxin connected to dementia, aborted foetal tissue and formaldehyde which is used to embalm corpses. World-renowned aluminium expert Christopher Exley had his research into the health effect of aluminium in vaccines shut down by Keele University in the UK when it began taking funding from the Bill and Melinda Gates Foundation. Research when diseases 'eradicated' by vaccines began to decline and you will find the fall began long *before* the vaccine was introduced. Sometimes the fall even plateaued after the vaccine. Diseases like scarlet fever for which there was no vaccine declined in the same way because of environmental and other factors. A perfect case in point is the polio vaccine. Polio began when lead arsenate was first sprayed as an insecticide and residues remained in food products. Spraying started in 1892 and the first US polio epidemic came in Vermont in 1894. The simple answer was to stop spraying, but Rockefeller-created Big Pharma had a better idea. Polio was decreed to be caused by the *poliovirus* which 'spreads from person to person and can infect a person's spinal cord'. Lead arsenate was replaced by the lethal DDT which had the same effect of causing paralysis by damaging the brain and central nervous



system. Polio plummeted when DDT was reduced and then banned, but the vaccine is still given the credit for something it didn't do. Today by far the biggest cause of polio is the vaccines promoted by Bill Gates. Vaccine justice campaigner Robert Kennedy Jr, son of assassinated (by the Cult) US Attorney General Robert Kennedy, wrote:

In 2017, the World Health Organization (WHO) reluctantly admitted that the global explosion in polio is predominantly vaccine strain. The most frightening epidemics in Congo, Afghanistan, and the Philippines, are all linked to vaccines. In fact, by 2018, 70% of global polio cases were vaccine strain.

Vaccines make fortunes for Cult-owned Gates and Big Pharma while undermining the health and immune systems of the population. We had a glimpse of the mentality behind the Big Pharma cartel with a report on WION (World is One News), an international English language TV station based in India, which exposed the extraordinary behaviour of US drug company Pfizer over its 'Covid vaccine'. The WION report told how Pfizer had made fantastic demands of Argentina, Brazil and other countries in return for its 'vaccine'. These included immunity from prosecution, even for Pfizer negligence, government insurance to protect Pfizer from law suits and handing over as collateral sovereign assets of the country to include Argentina's bank reserves, military bases and embassy buildings. Pfizer demanded the same of Brazil in the form of waiving sovereignty of its assets abroad; exempting Pfizer from Brazilian laws; and giving Pfizer immunity from all civil liability. This is a 'vaccine' developed with government funding. Big Pharma is evil incarnate as a creation of the Cult and all must be handed tickets to Nuremberg.

### **Phantom 'vaccine' for a phantom 'disease'**

I'll expose the 'Covid vaccine' fraud and then go on to the wider background of why the Cult has set out to 'vaccinate' every man, woman and child on the planet for an alleged 'new disease' with a survival rate of 99.77 percent (or more) even by the grotesquely-

manipulated figures of the World Health Organization and Johns Hopkins University. The 'infection' to 'death' ratio is 0.23 to 0.15 percent according to Stanford epidemiologist Dr John Ioannidis and while estimates vary the danger remains tiny. I say that if the truth be told the fake infection to fake death ratio is zero. Never mind all the evidence I have presented here and in *The Answer* that there is no 'virus' let us just focus for a moment on that death-rate figure of say 0.23 percent. The figure includes all those worldwide who have tested positive with a test not testing for the 'virus' and then died within 28 days or even longer of any other cause – *any other cause*. Now subtract all those illusory 'Covid' deaths on the global data sheets from the 0.23 percent. What do you think you would be left with? *Zero*. A vaccination has never been successfully developed for a so-called coronavirus. They have all failed at the animal testing stage when they caused hypersensitivity to what they were claiming to protect against and made the impact of a disease far worse. Cult-owned vaccine corporations got around that problem this time by bypassing animal trials, going straight to humans and making the length of the 'trials' before the public rollout as short as they could get away with. Normally it takes five to ten years or more to develop vaccines that still cause demonstrable harm to many people and that's without including the long-term effects that are never officially connected to the vaccination. 'Covid' non-vaccines have been officially produced and approved in a matter of months from a standing start and part of the reason is that (a) they were developed before the 'Covid' hoax began and (b) they are based on computer programs and not natural sources. Official non-trials were so short that government agencies gave *emergency*, not full, approval. 'Trials' were not even completed and full approval cannot be secured until they are. Public 'Covid vaccination' is actually a *continuation of the trial*. Drug company 'trials' are not scheduled to end until 2023 by which time a lot of people are going to be dead. Data on which government agencies gave this emergency approval was supplied by the Big Pharma corporations themselves in the form of Pfizer/BioNTech, AstraZeneca, Moderna, Johnson & Johnson, and

others, and this is the case with all vaccines. By its very nature *emergency* approval means drug companies do not have to prove that the 'vaccine' is 'safe and effective'. How could they with trials way short of complete? Government regulators only have to *believe* that they *could* be safe and effective. It is criminal manipulation to get products in circulation with no testing worth the name. Agencies giving that approval are infested with Big Pharma-connected place-people and they act in the interests of Big Pharma (the Cult) and not the public about whom they do not give a damn.

### **More human lab rats**

'Covid vaccines' produced in record time by Pfizer/BioNTech and Moderna employ a technique *never approved before for use on humans*. They are known as mRNA 'vaccines' and inject a synthetic version of 'viral' mRNA or 'messenger RNA'. The key is in the term 'messenger'. The body works, or doesn't, on the basis of information messaging. Communications are constantly passing between and within the genetic system and the brain. Change those messages and you change the state of the body and even its very nature and you can change psychology and behaviour by the way the brain processes information. I think you are going to see significant changes in personality and perception of many people who have had the 'Covid vaccine' synthetic potions. Insider Aldous Huxley predicted the following in 1961 and mRNA 'vaccines' can be included in the term 'pharmacological methods':

There will be, in the next generation or so, a pharmacological method of making people love their servitude, and producing dictatorship without tears, so to speak, producing a kind of painless concentration camp for entire societies, so that people will in fact have their own liberties taken away from them, but rather enjoy it, because they will be distracted from any desire to rebel by propaganda or brainwashing, or brainwashing enhanced by pharmacological methods. And this seems to be the final revolution.

Apologists claim that mRNA synthetic 'vaccines' don't change the DNA genetic blueprint because RNA does not affect DNA only the other way round. This is so disingenuous. A process called 'reverse

transcription' can convert RNA into DNA and be integrated into DNA in the cell nucleus. This was highlighted in December, 2020, by scientists at Harvard and Massachusetts Institute of Technology (MIT). Geneticists report that more than 40 percent of mammalian genomes results from reverse transcription. On the most basic level if messaging changes then that sequence must lead to changes in DNA which is receiving and transmitting those communications. How can introducing synthetic material into cells not change the cells where DNA is located? The process is known as transfection which is defined as 'a technique to insert foreign nucleic acid (DNA or RNA) into a cell, typically with the intention of altering the properties of the cell'. Researchers at the Sloan Kettering Institute in New York found that changes in messenger RNA can deactivate tumour-suppressing proteins and thereby promote cancer. This is what happens when you mess with messaging. 'Covid vaccine' maker Moderna was founded in 2010 by Canadian stem cell biologist Derrick J. Rossi after his breakthrough discovery in the field of transforming and reprogramming stem cells. These are neutral cells that can be programmed to become any cell including sperm cells. Moderna was therefore founded on the principle of genetic manipulation and has never produced any vaccine or drug before its genetically-manipulating synthetic 'Covid' shite. Look at the name – Mode-RNA or Modify-RNA. Another important point is that the US Supreme Court has ruled that genetically-modified DNA, or complementary DNA (cDNA) synthesized in the laboratory from messenger RNA, can be patented and owned. These psychopaths are doing this to the human body.

Cells replicate synthetic mRNA in the 'Covid vaccines' and in theory the body is tricked into making antigens which trigger antibodies to target the 'virus spike proteins' which as Dr Tom Cowan said have *never been seen*. Cut the crap and these 'vaccines' deliver *self-replicating* synthetic material to the cells with the effect of changing human DNA. The more of them you have the more that process is compounded while synthetic material is all the time self-replicating. 'Vaccine'-maker Moderna describes mRNA as 'like

software for the cell' and so they are messing with the body's software. What happens when you change the software in a computer? Everything changes. For this reason the Cult is preparing a production line of mRNA 'Covid vaccines' and a long list of excuses to use them as with all the 'variants' of a 'virus' never shown to exist. The plan is further to transfer the mRNA technique to other vaccines mostly given to children and young people. The cumulative consequences will be a transformation of human DNA through a constant infusion of synthetic genetic material which will kill many and change the rest. Now consider that governments that have given emergency approval for a vaccine that's not a vaccine; never been approved for humans before; had no testing worth the name; and the makers have been given immunity from prosecution for any deaths or adverse effects suffered by the public. The UK government awarded *permanent legal indemnity* to itself and its employees for harm done when a patient is being treated for 'Covid-19' or 'suspected Covid-19'. That is quite a thought when these are possible 'side-effects' from the 'vaccine' (they are not 'side', they are effects) listed by the US Food and Drug Administration:

Guillain-Barre syndrome; acute disseminated encephalomyelitis; transverse myelitis; encephalitis; myelitis; encephalomyelitis; meningoencephalitis; meningitis; encephalopathy; convulsions; seizures; stroke; narcolepsy; cataplexy; anaphylaxis; acute myocardial infarction (heart attack); myocarditis; pericarditis; autoimmune disease; death; implications for pregnancy, and birth outcomes; other acute demyelinating diseases; non anaphylactic allergy reactions; thrombocytopenia ; disseminated intravascular coagulation; venous thromboembolism; arthritis; arthralgia; joint pain; Kawasaki disease; multisystem inflammatory syndrome in children; vaccine enhanced disease. The latter is the way the 'vaccine' has the potential to make diseases far worse than they would otherwise be.

UK doctor and freedom campaigner Vernon Coleman described the conditions in this list as 'all unpleasant, most of them very serious, and you can't get more serious than death'. The thought that anyone at all has had the 'vaccine' in these circumstances is testament to the potential that humanity has for clueless, unquestioning, stupidity and for many that programmed stupidity has already been terminal.

## **An insider speaks**

Dr Michael Yeadon is a former Vice President, head of research and Chief Scientific Adviser at vaccine giant Pfizer. Yeadon worked on the inside of Big Pharma, but that did not stop him becoming a vocal critic of 'Covid vaccines' and their potential for multiple harms, including infertility in women. By the spring of 2021 he went much further and even used the no, no, term 'conspiracy'. When you begin to see what is going on it is impossible not to do so. Yeadon spoke out in an interview with freedom campaigner James Delingpole and I mentioned earlier how he said that no one had samples of 'the virus'. He explained that the mRNA technique originated in the anti-cancer field and ways to turn on and off certain genes which could be advantageous if you wanted to stop cancer growing out of control. 'That's the origin of them. They are a very unusual application, really.' Yeadon said that treating a cancer patient with an aggressive procedure might be understandable if the alternative was dying, but it was quite another thing to use the same technique as a public health measure. Most people involved wouldn't catch the infectious agent you were vaccinating against and if they did they probably wouldn't die:

If you are really using it as a public health measure you really want to as close as you can get to zero sides-effects ... I find it odd that they chose techniques that were really cutting their teeth in the field of oncology and I'm worried that in using gene-based vaccines that have to be injected in the body and spread around the body, get taken up into some cells, and the regulators haven't quite told us which cells they get taken up into ... you are going to be generating a wide range of responses ... with multiple steps each of which could go well or badly.

I doubt the Cult intends it to go well. Yeadon said that you can put any gene you like into the body through the 'vaccine'. 'You can certainly give them a gene that would do them some harm if you wanted.' I was intrigued when he said that when used in the cancer field the technique could turn genes on and off. I explore this process in *The Answer* and with different genes having different functions you could create mayhem – physically and psychologically – if you turned the wrong ones on and the right ones off. I read reports of an experiment by researchers at the University of Washington's school of computer science and engineering in which they encoded DNA to infect computers. The body is itself a biological computer and if human DNA can inflict damage on a computer why can't the computer via synthetic material mess with the human body? It can. The Washington research team said it was possible to insert malicious malware into 'physical DNA strands' and corrupt the computer system of a gene sequencing machine as it 'reads gene letters and stores them as binary digits 0 and 1'. They concluded that hackers could one day use blood or spit samples to access computer systems and obtain sensitive data from police forensics labs or infect genome files. It is at this level of digital interaction that synthetic 'vaccines' need to be seen to get the full picture and that will become very clear later on. Michael Yeadon said it made no sense to give the 'vaccine' to younger people who were in no danger from the 'virus'. What was the benefit? It was all downside with potential effects:

The fact that my government in what I thought was a civilised, rational country, is raining [the 'vaccine'] on people in their 30s and 40s, even my children in their 20s, they're getting letters and phone calls, I know this is not right and any of you doctors who are vaccinating you know it's not right, too. They are not at risk. They are not at risk from the disease, so you are now hoping that the side-effects are so rare that you get away with it. You don't give new technology ... that you don't understand to 100 percent of the population.

Blood clot problems with the AstraZeneca 'vaccine' have been affecting younger people to emphasise the downside risks with no benefit. AstraZeneca's version, produced with Oxford University, does not use mRNA, but still gets its toxic cocktail inside cells where

it targets DNA. The Johnson & Johnson 'vaccine' which uses a similar technique has also produced blood clot effects to such an extent that the United States paused its use at one point. They are all 'gene therapy' (cell modification) procedures and not 'vaccines'. The truth is that once the content of these injections enter cells we have no idea what the effect will be. People can speculate and some can give very educated opinions and that's good. In the end, though, only the makers know what their potions are designed to do and even they won't know every last consequence. Michael Yeadon was scathing about doctors doing what they knew to be wrong. 'Everyone's mute', he said. Doctors in the NHS must know this was not right, coming into work and injecting people. 'I don't know how they sleep at night. I know I couldn't do it. I know that if I were in that position I'd have to quit.' He said he knew enough about toxicology to know this was not a good risk-benefit. Yeadon had spoken to seven or eight university professors and all except two would not speak out publicly. Their universities had a policy that no one said anything that countered the government and its medical advisors. They were afraid of losing their government grants. This is how intimidation has been used to silence the truth at every level of the system. I say silence, but these people could still speak out if they made that choice. Yeadon called them 'moral cowards' – 'This is about your children and grandchildren's lives and you have just buggered off and left it.'

### **'Variant' nonsense**

Some of his most powerful comments related to the alleged 'variants' being used to instil more fear, justify more lockdowns, and introduce more 'vaccines'. He said government claims about 'variants' were nonsense. He had checked the alleged variant 'codes' and they were 99.7 percent identical to the 'original'. This was the human identity difference equivalent to putting a baseball cap on and off or wearing it the other way round. A 0.3 percent difference would make it impossible for that 'variant' to escape immunity from the 'original'. This made no sense of having new 'vaccines' for



'variants'. He said there would have to be at least a *30 percent* difference for that to be justified and even then he believed the immune system would still recognise what it was. Gates-funded 'variant modeller' and 'vaccine'-pusher John Edmunds might care to comment. Yeadon said drug companies were making new versions of the 'vaccine' as a 'top up' for 'variants'. Worse than that, he said, the 'regulators' around the world like the MHRA in the UK had got together and agreed that because 'vaccines' for 'variants' were so similar to the first 'vaccines' *they did not have to do safety studies*. How transparently sinister that is. This is when Yeadon said: 'There is a conspiracy here.' There was no need for another vaccine for 'variants' and yet we were told that there was and the country had shut its borders because of them. 'They are going into hundreds of millions of arms without passing 'go' or any regulator. Why did they do that? Why did they pick this method of making the vaccine?'

The reason had to be something bigger than that it seemed and 'it's not protection against the virus'. It's was a far bigger project that meant politicians and advisers were willing to do things and not do things that knowingly resulted in avoidable deaths – 'that's already happened when you think about lockdown and deprivation of health care for a year.' He spoke of people prepared to do something that results in the avoidable death of their fellow human beings and it not bother them. This is the penny-drop I have been working to get across for more than 30 years – the level of pure evil we are dealing with. Yeadon said his friends and associates could not believe there could be that much evil, but he reminded them of Stalin, Pol Pot and Hitler and of what Stalin had said: 'One death is a tragedy. A million? A statistic.' He could not think of a benign explanation for why you need top-up vaccines 'which I'm sure you don't' and for the regulators 'to just get out of the way and wave them through'. Why would the regulators do that when they were still wrestling with the dangers of the 'parent' vaccine? He was clearly shocked by what he had seen since the 'Covid' hoax began and now he was thinking the previously unthinkable:

If you wanted to depopulate a significant proportion of the world and to do it in a way that doesn't involve destruction of the environment with nuclear weapons, poisoning everyone with anthrax or something like that, and you wanted plausible deniability while you had a multi-year infectious disease crisis, I actually don't think you could come up with a better plan of work than seems to be in front of me. I can't say that's what they are going to do, but I can't think of a benign explanation why they are doing it.

He said he never thought that they would get rid of 99 percent of humans, but now he wondered. 'If you wanted to that this would be a hell of a way to do it – it would be unstoppable folks.' Yeadon had concluded that those who submitted to the 'vaccine' would be allowed to have some kind of normal life (but for how long?) while screws were tightened to coerce and mandate the last few percent. 'I think they'll put the rest of them in a prison camp. I wish I was wrong, but I don't think I am.' Other points he made included: There were no coronavirus vaccines then suddenly they all come along at the same time; we have no idea of the long term affect with trials so short; coercing or forcing people to have medical procedures is against the Nuremberg Code instigated when the Nazis did just that; people should at least delay having the 'vaccine'; a quick Internet search confirms that masks don't reduce respiratory viral transmission and 'the government knows that'; they have smashed civil society and they know that, too; two dozen peer-reviewed studies show no connection between lockdown and reducing deaths; he knew from personal friends the elite were still flying around and going on holiday while the public were locked down; the elite were not having the 'vaccines'. He was also asked if 'vaccines' could be made to target difference races. He said he didn't know, but the document by the Project for the New American Century in September, 2000, said developing 'advanced forms of biological warfare that can target *specific genotypes* may transform biological warfare from the realm of terror to a politically useful tool.' Oh, they're evil all right. Of that we can be *absolutely* sure.

## **Another cull of old people**

We have seen from the CDC definition that the mRNA 'Covid vaccine' is not a vaccine and nor are the others that *claim* to reduce 'severity of symptoms' in *some* people, but not protect from infection or transmission. What about all the lies about returning to 'normal' if people were 'vaccinated'? If they are not claimed to stop infection and transmission of the alleged 'virus', how does anything change? This was all lies to manipulate people to take the jabs and we are seeing that now with masks and distancing still required for the 'vaccinated'. How did they think that elderly people with fragile health and immune responses were going to be affected by infusing their cells with synthetic material and other toxic substances? They *knew* that in the short and long term it would be devastating and fatal as the culling of the old that began with the first lockdowns was continued with the 'vaccine'. Death rates in care homes soared immediately residents began to be 'vaccinated' – infused with synthetic material. Brave and committed whistleblower nurses put their careers at risk by exposing this truth while the rest kept their heads down and their mouths shut to put their careers before those they are supposed to care for. A long-time American Certified Nursing Assistant who gave his name as James posted a video in which he described emotionally what happened in his care home when vaccination began. He said that during 2020 very few residents were sick with 'Covid' and no one died during the entire year; but shortly after the Pfizer mRNA injections 14 people died within two weeks and many others were near death. 'They're dropping like flies', he said. Residents who walked on their own before the shot could no longer and they had lost their ability to conduct an intelligent conversation. The home's management said the sudden deaths were caused by a 'super-spreader' of 'Covid-19'. Then how come, James asked, that residents who refused to take the injections were not sick? It was a case of inject the elderly with mRNA synthetic potions and blame their illness and death that followed on the 'virus'. James described what was happening in care homes as 'the greatest crime of genocide this country has ever seen'. Remember the NHS staff nurse from earlier who used the same

word 'genocide' for what was happening with the 'vaccines' and that it was an 'act of human annihilation'. A UK care home whistleblower told a similar story to James about the effect of the 'vaccine' in deaths and 'outbreaks' of illness dubbed 'Covid' after getting the jab. She told how her care home management and staff had zealously imposed government regulations and no one was allowed to even question the official narrative let alone speak out against it. She said the NHS was even worse. Again we see the results of reframing. A worker at a local care home where I live said they had not had a single case of 'Covid' there for almost a year and when the residents were 'vaccinated' they had 19 positive cases in two weeks with eight dying.

### **It's not the 'vaccine' – honest**

The obvious cause and effect was being ignored by the media and most of the public. Australia's health minister Greg Hunt (a former head of strategy at the World Economic Forum) was admitted to hospital after he had the 'vaccine'. He was suffering according to reports from the skin infection 'cellulitis' and it must have been a severe case to have warranted days in hospital. Immediately the authorities said this was nothing to do with the 'vaccine' when an effect of some vaccines is a 'cellulitis-like reaction'. We had families of perfectly healthy old people who died after the 'vaccine' saying that if only they had been given the 'vaccine' earlier they would still be alive. As a numbskull rating that is off the chart. A father of four 'died of Covid' at aged 48 when he was taken ill two days after having the 'vaccine'. The man, a health administrator, had been 'shielding during the pandemic' and had 'not really left the house' until he went for the 'vaccine'. Having the 'vaccine' and then falling ill and dying does not seem to have qualified as a possible cause and effect and 'Covid-19' went on his death certificate. His family said they had no idea how he 'caught the virus'. A family member said: 'Tragically, it could be that going for a vaccination ultimately led to him catching Covid ...The sad truth is that they are never going to know where it came from.' The family warned people to remember

that the virus still existed and was 'very real'. So was their stupidity. Nurses and doctors who had the first round of the 'vaccine' were collapsing, dying and ending up in a hospital bed while they or their grieving relatives were saying they'd still have the 'vaccine' again despite what happened. I kid you not. You mean if your husband returned from the dead he'd have the same 'vaccine' again that killed him??

Doctors at the VCU Medical Center in Richmond, Virginia, said the Johnson & Johnson 'vaccine' was to blame for a man's skin peeling off. Patient Richard Terrell said: 'It all just happened so fast. My skin peeled off. It's still coming off on my hands now.' He said it was stinging, burning and itching and when he bent his arms and legs it was very painful with 'the skin swollen and rubbing against itself'. Pfizer/BioNTech and Moderna vaccines use mRNA to change the cell while the Johnson & Johnson version uses DNA in a process similar to AstraZeneca's technique. Johnson & Johnson and AstraZeneca have both had their 'vaccines' paused by many countries after causing serious blood problems. Terrell's doctor Fnu Nutan said he could have died if he hadn't got medical attention. It sounds terrible so what did Nutan and Terrell say about the 'vaccine' now? Oh, they still recommend that people have it. A nurse in a hospital bed 40 minutes after the vaccination and unable to swallow due to throat swelling was told by a doctor that he lost mobility in his arm for 36 hours following the vaccination. What did he say to the ailing nurse? 'Good for you for getting the vaccination.' We are dealing with a serious form of cognitive dissonance madness in both public and medical staff. There is a remarkable correlation between those having the 'vaccine' and trumpeting the fact and suffering bad happenings shortly afterwards. Witold Rogiewicz, a Polish doctor, made a video of his 'vaccination' and ridiculed those who were questioning its safety and the intentions of Bill Gates: 'Vaccinate yourself to protect yourself, your loved ones, friends and also patients. And to mention quickly I have info for anti-vaxxers and anti-Coviders if you want to contact Bill Gates you can do this through me.' He further ridiculed the dangers of 5G. Days later he

was dead, but naturally the vaccination wasn't mentioned in the verdict of 'heart attack'.

## **Lies, lies and more lies**

So many members of the human race have slipped into extreme states of insanity and unfortunately they include reframed doctors and nursing staff. Having a 'vaccine' and dying within minutes or hours is not considered a valid connection while death from any cause within 28 days or longer of a positive test with a test not testing for the 'virus' means 'Covid-19' goes on the death certificate. How could that 'vaccine'-death connection not have been made except by calculated deceit? US figures in the initial rollout period to February 12th, 2020, revealed that a third of the deaths reported to the CDC after 'Covid vaccines' happened within 48 hours. Five men in the UK suffered an 'extremely rare' blood clot problem after having the AstraZeneca 'vaccine', but no causal link was established said the Gates-funded Medicines and Healthcare products Regulatory Agency (MHRA) which had given the 'vaccine' emergency approval to be used. Former Pfizer executive Dr Michael Yeadon explained in his interview how the procedures could cause blood coagulation and clots. People who should have been at no risk were dying from blood clots in the brain and he said he had heard from medical doctor friends that people were suffering from skin bleeding and massive headaches. The AstraZeneca 'shot' was stopped by some 20 countries over the blood clotting issue and still the corrupt MHRA, the European Medicines Agency (EMA) and the World Health Organization said that it should continue to be given even though the EMA admitted that it 'still cannot rule out definitively' a link between blood clotting and the 'vaccine'. Later Marco Cavaleri, head of EMA vaccine strategy, said there was indeed a clear link between the 'vaccine' and thrombosis, but they didn't know why. So much for the trials showing the 'vaccine' is safe. Blood clots were affecting younger people who would be under virtually no danger from 'Covid' even if it existed which makes it all the more stupid and sinister.

The British government responded to public alarm by wheeling out June Raine, the terrifyingly weak infant school headmistress sound-alike who heads the UK MHRA drug 'regulator'. The idea that she would stand up to Big Pharma and government pressure is laughable and she told us that all was well in the same way that she did when allowing untested, never-used-on-humans-before, genetically-manipulating 'vaccines' to be exposed to the public in the first place. Mass lying is the new normal of the 'Covid' era. The MHRA later said 30 cases of rare blood clots had by then been connected with the AstraZeneca 'vaccine' (that means a lot more in reality) while stressing that the benefits of the jab in preventing 'Covid-19' outweighed any risks. A more ridiculous and disingenuous statement with callous disregard for human health it is hard to contemplate. Immediately after the mendacious 'all-clears' two hospital workers in Denmark experienced blood clots and cerebral haemorrhaging following the AstraZeneca jab and one died. Top Norwegian health official Pål Andre Holme said the 'vaccine' was the only common factor: 'There is nothing in the patient history of these individuals that can give such a powerful immune response ... I am confident that the antibodies that we have found are the cause, and I see no other explanation than it being the vaccine which triggers it.' Strokes, a clot or bleed in the brain, were clearly associated with the 'vaccine' from word of mouth and whistleblower reports. Similar consequences followed with all these 'vaccines' that we were told were so safe and as the numbers grew by the day it was clear we were witnessing human carnage.

### **Learning the hard way**

A woman interviewed by UKColumn told how her husband suffered dramatic health effects after the vaccine when he'd been in good health all his life. He went from being a little unwell to losing all feeling in his legs and experiencing 'excruciating pain'. Misdiagnosis followed twice at Accident and Emergency (an 'allergy' and 'sciatica') before he was admitted to a neurology ward where doctors said his serious condition had been caused by the

'vaccine'. Another seven 'vaccinated' people were apparently being treated on the same ward for similar symptoms. The woman said he had the 'vaccine' because they believed media claims that it was safe. 'I didn't think the government would give out a vaccine that does this to somebody; I believed they would be bringing out a vaccination that would be safe.' What a tragic way to learn that lesson. Another woman posted that her husband was transporting stroke patients to hospital on almost every shift and when he asked them if they had been 'vaccinated' for 'Covid' they all replied 'yes'. One had a 'massive brain bleed' the day after his second dose. She said her husband reported the 'just been vaccinated' information every time to doctors in A and E only for them to ignore it, make no notes and appear annoyed that it was even mentioned. This particular report cannot be verified, but it expresses a common theme that confirms the monumental underreporting of 'vaccine' consequences. Interestingly as the 'vaccines' and their brain blood clot/stroke consequences began to emerge the UK National Health Service began a publicity campaign telling the public what to do in the event of a stroke. A Scottish NHS staff nurse who quit in disgust in March, 2021, said:

I have seen traumatic injuries from the vaccine, they're not getting reported to the yellow card [adverse reaction] scheme, they're treating the symptoms, not asking why, why it's happening. It's just treating the symptoms and when you speak about it you're dismissed like you're crazy, I'm not crazy, I'm not crazy because every other colleague I've spoken to is terrified to speak out, they've had enough.

Videos appeared on the Internet of people uncontrollably shaking after the 'vaccine' with no control over muscles, limbs and even their face. A Scottish mother broke out in a severe rash all over her body almost immediately after she was given the AstraZeneca 'vaccine'. The pictures were horrific. Leigh King, a 41-year-old hairdresser from Lanarkshire said: 'Never in my life was I prepared for what I was about to experience ... My skin was so sore and constantly hot ... I have never felt pain like this ...' But don't you worry, the 'vaccine' is perfectly safe. Then there has been the effect on medical



staff who have been pressured to have the 'vaccine' by psychopathic 'health' authorities and government. A London hospital consultant who gave the name K. Polyakova wrote this to the *British Medical Journal* or *BMJ*:

I am currently struggling with ... the failure to report the reality of the morbidity caused by our current vaccination program within the health service and staff population. The levels of sickness after vaccination is unprecedented and staff are getting very sick and some with neurological symptoms which is having a huge impact on the health service function. Even the young and healthy are off for days, some for weeks, and some requiring medical treatment. Whole teams are being taken out as they went to get vaccinated together.

Mandatory vaccination in this instance is stupid, unethical and irresponsible when it comes to protecting our staff and public health. We are in the voluntary phase of vaccination, and encouraging staff to take an unlicensed product that is impacting on their immediate health ... it is clearly stated that these vaccine products do not offer immunity or stop transmission. In which case why are we doing it?

Not to protect health that's for sure. Medical workers are lauded by governments for agenda reasons when they couldn't give a toss about them any more than they can for the population in general. Schools across America faced the same situation as they closed due to the high number of teachers and other staff with bad reactions to the Pfizer/BioNTech, Moderna, and Johnson & Johnson 'Covid vaccines' all of which were linked to death and serious adverse effects. The *BMJ* took down the consultant's comments pretty quickly on the grounds that they were being used to spread 'disinformation'. They were exposing the truth about the 'vaccine' was the real reason. The cover-up is breathtaking.

## **Hiding the evidence**

The scale of the 'vaccine' death cover-up worldwide can be confirmed by comparing official figures with the personal experience of the public. I heard of many people in my community who died immediately or soon after the vaccine that would never appear in the media or even likely on the official totals of 'vaccine' fatalities and adverse reactions when only about ten percent are estimated to be

reported and I have seen some estimates as low as one percent in a Harvard study. In the UK alone by April 29th, 2021, some 757,654 adverse reactions had been officially reported from the Pfizer/BioNTech, Oxford/AstraZeneca and Moderna 'vaccines' with more than a thousand deaths linked to jabs and that means an estimated ten times this number in reality from a ten percent reporting rate percentage. That's seven million adverse reactions and 10,000 potential deaths and a one percent reporting rate would be ten times *those* figures. In 1976 the US government pulled the swine flu vaccine after 53 deaths. The UK data included a combined 10,000 eye disorders from the 'Covid vaccines' with more than 750 suffering visual impairment or blindness and again multiply by the estimated reporting percentages. As 'Covid cases' officially fell hospitals virtually empty during the 'Covid crisis' began to fill up with a range of other problems in the wake of the 'vaccine' rollout. The numbers across America have also been catastrophic. Deaths linked to *all* types of vaccine increased by 6,000 percent in the first quarter of 2021 compared with 2020. A 39-year-old woman from Ogden, Utah, died four days after receiving a second dose of Moderna's 'Covid vaccine' when her liver, heart and kidneys all failed despite the fact that she had no known medical issues or conditions. Her family sought an autopsy, but Dr Erik Christensen, Utah's chief medical examiner, said proving vaccine injury as a cause of death almost never happened. He could think of only one instance where an autopsy would name a vaccine as the official cause of death and that would be anaphylaxis where someone received a vaccine and died almost instantaneously. 'Short of that, it would be difficult for us to definitively say this is the vaccine,' Christensen said. If that is true this must be added to the estimated ten percent (or far less) reporting rate of vaccine deaths and serious reactions and the conclusion can only be that vaccine deaths and serious reactions – including these 'Covid' potions' – are phenomenally understated in official figures. The same story can be found everywhere. Endless accounts of deaths and serious reactions among the public, medical

and care home staff while official figures did not even begin to reflect this.

Professional script-reader Dr David Williams, a 'top public-health official' in Ontario, Canada, insulted our intelligence by claiming only four serious adverse reactions and no deaths from the more than 380,000 vaccine doses then given. This bore no resemblance to what people knew had happened in their own circles and we had Dirk Huyer in charge of getting millions vaccinated in Ontario while at the same time he was Chief Coroner for the province investigating causes of death including possible death from the vaccine. An aide said he had stepped back from investigating deaths, but evidence indicated otherwise. Rosemary Frei, who secured a Master of Science degree in molecular biology at the Faculty of Medicine at Canada's University of Calgary before turning to investigative journalism, was one who could see that official figures for 'vaccine' deaths and reactions made no sense. She said that doctors seldom reported adverse events and when people got really sick or died after getting a vaccination they would attribute that to anything except the vaccines. It had been that way for years and anyone who wondered aloud whether the 'Covid vaccines' or other shots cause harm is immediately branded as 'anti-vax' and 'anti-science'. This was 'career-threatening' for health professionals. Then there was the huge pressure to support the push to 'vaccinate' billions in the quickest time possible. Frei said:

So that's where we're at today. More than half a million vaccine doses have been given to people in Ontario alone. The rush is on to vaccinate all 15 million of us in the province by September. And the mainstream media are screaming for this to be sped up even more. That all adds up to only a very slim likelihood that we're going to be told the truth by officials about how many people are getting sick or dying from the vaccines.

What is true of Ontario is true of everywhere.

### **They KNEW – and still did it**

The authorities knew what was going to happen with multiple deaths and adverse reactions. The UK government's Gates-funded

and Big Pharma-dominated Medicines and Healthcare products Regulatory Agency (MHRA) hired a company to employ AI in compiling the projected reactions to the 'vaccine' that would otherwise be uncountable. The request for applications said: 'The MHRA urgently seeks an Artificial Intelligence (AI) software tool to process the expected high volume of Covid-19 vaccine Adverse Drug Reaction ...' This was from the agency, headed by the disingenuous June Raine, that gave the 'vaccines' emergency approval and the company was hired before the first shot was given. 'We are going to kill and maim you – is that okay?' 'Oh, yes, perfectly fine – I'm very grateful, thank you, doctor.' The range of 'Covid vaccine' adverse reactions goes on for page after page in the MHRA criminally underreported 'Yellow Card' system and includes affects to eyes, ears, skin, digestion, blood and so on. Raine's MHRA amazingly claimed that the 'overall safety experience ... is so far as expected from the clinical trials'. The death, serious adverse effects, deafness and blindness were *expected*? When did they ever mention that? If these human tragedies were expected then those that gave approval for the use of these 'vaccines' must be guilty of crimes against humanity including murder – a definition of which is 'killing a person with malice aforethought or with recklessness manifesting extreme indifference to the value of human life.' People involved at the MHRA, the CDC in America and their equivalent around the world must go before Nuremberg trials to answer for their callous inhumanity. We are only talking here about the immediate effects of the 'vaccine'. The longer-term impact of the DNA synthetic manipulation is the main reason they are so hysterically desperate to inoculate the entire global population in the shortest possible time.

Africa and the developing world are a major focus for the 'vaccine' depopulation agenda and a mass vaccination sales-pitch is underway thanks to caring people like the Rockefellers and other Cult assets. The Rockefeller Foundation, which pre-empted the 'Covid pandemic' in a document published in 2010 that 'predicted' what happened a decade later, announced an initial \$34.95 million grant in February, 2021, 'to ensure more equitable access to Covid-19

testing and vaccines' among other things in Africa in collaboration with '24 organizations, businesses, and government agencies'. The pan-Africa initiative would focus on 10 countries: Burkina Faso, Ethiopia, Ghana, Kenya, Nigeria, Rwanda, South Africa, Tanzania, Uganda, and Zambia'. Rajiv Shah, President of the Rockefeller Foundation and former administrator of CIA-controlled USAID, said that if Africa was not mass-vaccinated (to change the DNA of its people) it was a 'threat to all of humanity' and not fair on Africans. When someone from the Rockefeller Foundation says they want to do something to help poor and deprived people and countries it is time for a belly-laugh. They are doing this out of the goodness of their 'heart' because 'vaccinating' the entire global population is what the 'Covid' hoax set out to achieve. Official 'decolonisation' of Africa by the Cult was merely a prelude to financial colonisation on the road to a return to physical colonisation. The 'vaccine' is vital to that and the sudden and convenient death of the 'Covid' sceptic president of Tanzania can be seen in its true light. A lot of people in Africa are aware that this is another form of colonisation and exploitation and they need to stand their ground.

### **The 'vaccine is working' scam**

A potential problem for the Cult was that the 'vaccine' is meant to change human DNA and body messaging and not to protect anyone from a 'virus' never shown to exist. The vaccine couldn't work because it was not designed to work and how could they make it *appear* to be working so that more people would have it? This was overcome by lowering the amplification rate of the PCR test to produce fewer 'cases' and therefore fewer 'deaths'. Some of us had been pointing out since March, 2020, that the amplification rate of the test not testing for the 'virus' had been made artificially high to generate positive tests which they could call 'cases' to justify lockdowns. The World Health Organization recommended an absurdly high 45 amplification cycles to ensure the high positives required by the Cult and then remained silent on the issue until January 20th, 2021 – Biden's Inauguration Day. This was when the

'vaccinations' were seriously underway and on that day the WHO recommended after discussions with America's CDC that laboratories *lowered their testing amplification*. Dr David Samadi, a certified urologist and health writer, said the WHO was encouraging all labs to reduce their cycle count for PCR tests. He said the current cycle was much too high and was 'resulting in any particle being declared a positive case'. Even one mainstream news report I saw said this meant the number of 'Covid' infections may have been 'dramatically inflated'. Oh, just a little bit. The CDC in America issued new guidance to laboratories in April, 2021, to use 28 cycles *but only for 'vaccinated' people*. The timing of the CDC/WHO interventions were cynically designed to make it appear the 'vaccines' were responsible for falling cases and deaths when the real reason can be seen in the following examples. New York's state lab, the Wadsworth Center, identified 872 positive tests in July, 2020, based on a threshold of 40 cycles. When the figure was lowered to 35 cycles 43 percent of the 872 were no longer 'positives'. At 30 cycles the figure was 63 percent. A Massachusetts lab found that between 85 to 90 percent of people who tested positive in July with a cycle threshold of 40 would be negative at 30 cycles, Ashish Jha, MD, director of the Harvard Global Health Institute, said: 'I'm really shocked that it could be that high ... Boy, does it really change the way we need to be thinking about testing.' I'm shocked that I could see the obvious in the spring of 2020, with no medical background, and most medical professionals still haven't worked it out. No, that's not shocking – it's terrifying.

Three weeks after the WHO directive to lower PCR cycles the London *Daily Mail* ran this headline: 'Why ARE Covid cases plummeting? New infections have fallen 45% in the US and 30% globally in the past 3 weeks but experts say vaccine is NOT the main driver because only 8% of Americans and 13% of people worldwide have received their first dose.' They acknowledged that the drop could not be attributed to the 'vaccine', but soon this morphed throughout the media into the 'vaccine' has caused cases and deaths to fall when it was the PCR threshold. In December, 2020, there was

chaos at English Channel ports with truck drivers needing negative 'Covid' tests before they could board a ferry home for Christmas. The government wanted to remove the backlog as fast as possible and they brought in troops to do the 'testing'. Out of 1,600 drivers just 36 tested positive and the rest were given the all clear to cross the Channel. I guess the authorities thought that 36 was the least they could get away with without the unquestioning catching on. The amplification trick which most people believed in the absence of information in the mainstream applied more pressure on those refusing the 'vaccine' to succumb when it 'obviously worked'. The truth was the exact opposite with deaths in care homes soaring with the 'vaccine' and in Israel the term used was 'skyrocket'. A re-analysis of published data from the Israeli Health Ministry led by Dr Hervé Seligmann at the Medicine Emerging Infectious and Tropical Diseases at Aix-Marseille University found that Pfizer's 'Covid vaccine' killed 'about 40 times more [elderly] people than the disease itself would have killed' during a five-week vaccination period and *260 times* more younger people than would have died from the 'virus' even according to the manipulated 'virus' figures. Dr Seligmann and his co-study author, Haim Yativ, declared after reviewing the Israeli 'vaccine' death data: 'This is a new Holocaust.'

Then, in mid-April, 2021, after vast numbers of people worldwide had been 'vaccinated', the story changed with clear coordination. The UK government began to prepare the ground for more future lockdowns when Nuremberg-destined Boris Johnson told yet another whopper. He said that cases had fallen because of *lockdowns* not 'vaccines'. Lockdowns are irrelevant when *there is no 'virus'* and the test and fraudulent death certificates are deciding the number of 'cases' and 'deaths'. Study after study has shown that lockdowns don't work and instead kill and psychologically destroy people. Meanwhile in the United States Anthony Fauci and Rochelle Walensky, the ultra-Zionist head of the CDC, peddled the same line. More lockdown was the answer and not the 'vaccine', a line repeated on cue by the moron that is Canadian Prime Minister Justin Trudeau. Why all the hysteria to get everyone 'vaccinated' if lockdowns and

not 'vaccines' made the difference? None of it makes sense on the face of it. Oh, but it does. The Cult wants lockdowns *and* the 'vaccine' and if the 'vaccine' is allowed to be seen as the total answer lockdowns would no longer be justified when there are still livelihoods to destroy. 'Variants' and renewed upward manipulation of PCR amplification are planned to instigate never-ending lockdown *and* more 'vaccines'.

### **You *must* have it – we're desperate**

Israel, where the Jewish and Arab population are ruled by the Sabbatian Cult, was the front-runner in imposing the DNA-manipulating 'vaccine' on its people to such an extent that Jewish refusers began to liken what was happening to the early years of Nazi Germany. This would seem to be a fantastic claim. Why would a government of Jewish people be acting like the Nazis did? If you realise that the Sabbatian Cult was behind the Nazis and that Sabbatians hate Jews the pieces start to fit and the question of why a 'Jewish' government would treat Jews with such callous disregard for their lives and freedom finds an answer. Those controlling the government of Israel *aren't Jewish* – they're Sabbatian. Israeli lawyer Tamir Turgal was one who made the Nazi comparison in comments to German lawyer Reiner Fuellmich who is leading a class action lawsuit against the psychopaths for crimes against humanity. Turgal described how the Israeli government was vaccinating children and pregnant women on the basis that there was no evidence that this was dangerous when they had no evidence that it *wasn't* dangerous either. They just had no evidence. This was medical experimentation and Turgal said this breached the Nuremberg Code about medical experimentation and procedures requiring informed consent and choice. Think about that. A Nuremberg Code developed because of Nazi experimentation on Jews and others in concentration camps by people like the evil-beyond-belief Josef Mengele is being breached by the *Israeli* government; but when you know that it's a *Sabbatian* government along with its intelligence and military agencies like Mossad, Shin Bet and the Israeli Defense Forces, and that Sabbatians



were the force behind the Nazis, the kaleidoscope comes into focus. What have we come to when Israeli Jews are suing their government for violating the Nuremberg Code by essentially making Israelis subject to a medical experiment using the controversial 'vaccines'? It's a shocker that this has to be done in the light of what happened in Nazi Germany. The Anshe Ha-Emet, or 'People of the Truth', made up of Israeli doctors, lawyers, campaigners and public, have launched a lawsuit with the International Criminal Court. It says:

When the heads of the Ministry of Health as well as the prime minister presented the vaccine in Israel and began the vaccination of Israeli residents, the vaccinated were not advised, that, in practice, they are taking part in a medical experiment and that their consent is required for this under the Nuremberg Code.

The irony is unbelievable, but easily explained in one word: Sabbatians. The foundation of Israeli 'Covid' apartheid is the 'green pass' or 'green passport' which allows Jews and Arabs who have had the DNA-manipulating 'vaccine' to go about their lives – to work, fly, travel in general, go to shopping malls, bars, restaurants, hotels, concerts, gyms, swimming pools, theatres and sports venues, while non-'vaccinated' are banned from all those places and activities. Israelis have likened the 'green pass' to the yellow stars that Jews in Nazi Germany were forced to wear – the same as the yellow stickers that a branch of UK supermarket chain Morrisons told exempt mask-wearers they had to display when shopping. How very sensitive. The Israeli system is blatant South African-style apartheid on the basis of compliance or non-compliance to fascism rather than colour of the skin. How appropriate that the Sabbatian Israeli government was so close to the pre-Mandela apartheid regime in Pretoria. The Sabbatian-instigated 'vaccine passport' in Israel is planned for everywhere. Sabbatians struck a deal with Pfizer that allowed them to lead the way in the percentage of a national population infused with synthetic material and the result was catastrophic. Israeli freedom activist Shai Dannon told me how chairs were appearing on beaches that said 'vaccinated only'. Health Minister Yuli Edelstein said that anyone unwilling or unable to get

the jabs that 'confer immunity' will be 'left behind'. The man's a liar. Not even the makers claim the 'vaccines' confer immunity. When you see those figures of 'vaccine' deaths these psychopaths were saying that you must take the chance the 'vaccine' will kill you or maim you while knowing it will change your DNA or lockdown for you will be permanent. That's fascism. The Israeli parliament passed a law to allow personal information of the non-vaccinated to be shared with local and national authorities for three months. This was claimed by its supporters to be a way to 'encourage' people to be vaccinated. Hadas Ziv from Physicians for Human Rights described this as a 'draconian law which crushed medical ethics and the patient rights'. But that's the idea, the Sabbatians would reply.

### **Your papers, please**

Sabbatian Israel was leading what has been planned all along to be a global 'vaccine pass' called a 'green passport' without which you would remain in permanent lockdown restriction and unable to do anything. This is how badly – *desperately* – the Cult is to get everyone 'vaccinated'. The term and colour 'green' was not by chance and related to the psychology of fusing the perception of the green climate hoax with the 'Covid' hoax and how the 'solution' to both is the same Great Reset. Lying politicians, health officials and psychologists denied there were any plans for mandatory vaccinations or restrictions based on vaccinations, but they knew that was exactly what was meant to happen with governments of all countries reaching agreements to enforce a global system. 'Free' Denmark and 'free' Sweden unveiled digital vaccine certification. Cyprus, Czech Republic, Estonia, Greece, Hungary, Iceland, Italy, Poland, Portugal, Slovakia, and Spain have all committed to a vaccine passport system and the rest including the whole of the EU would follow. The satanic UK government will certainly go this way despite mendacious denials and at the time of writing it is trying to manipulate the public into having the 'vaccine' so they could go abroad on a summer holiday. How would that work without something to prove you had the synthetic toxicity injected into you?

Documents show that the EU's European Commission was moving towards 'vaccine certificates' in 2018 and 2019 before the 'Covid' hoax began. They knew what was coming. Abracadabra – Ursula von der Leyen, the German President of the Commission, announced in March, 2021, an EU 'Digital Green Certificate' – green again – to track the public's 'Covid status'. The passport sting is worldwide and the Far East followed the same pattern with South Korea ruling that only those with 'vaccination' passports – again the *green* pass – would be able to 'return to their daily lives'.

Bill Gates has been preparing for this 'passport' with other Cult operatives for years and beyond the paper version is a Gates-funded 'digital tattoo' to identify who has been vaccinated and who hasn't. The 'tattoo' is reported to include a substance which is externally readable to confirm who has been vaccinated. This is a bio-luminous light-generating enzyme (think fireflies) called ... *Luciferase*. Yes, named after the Cult 'god' Lucifer the 'light bringer' of whom more to come. Gates said he funded the readable tattoo to ensure children in the developing world were vaccinated and no one was missed out. He cares so much about poor kids as we know. This was just the cover story to develop a vaccine tagging system for everyone on the planet. Gates has been funding the ID2020 'alliance' to do just that in league with other lovely people at Microsoft, GAVI, the Rockefeller Foundation, Accenture and IDEO.org. He said in interviews in March, 2020, before any 'vaccine' publicly existed, that the world must have a globalised digital certificate to track the 'virus' and who had been vaccinated. Gates knew from the start that the mRNA vaccines were coming and when they would come and that the plan was to tag the 'vaccinated' to marginalise the intelligent and stop them doing anything including travel. Evil just doesn't suffice. Gates was exposed for offering a \$10 million bribe to the Nigerian House of Representatives to invoke compulsory 'Covid' vaccination of all Nigerians. Sara Cunial, a member of the Italian Parliament, called Gates a 'vaccine criminal'. She urged the Italian President to hand him over to the International Criminal Court for crimes against

humanity and condemned his plans to 'chip the human race' through ID2020.

You know it's a long-planned agenda when war criminal and Cult gofer Tony Blair is on the case. With the scale of arrogance only someone as dark as Blair can muster he said: 'Vaccination in the end is going to be your route to liberty.' Blair is a disgusting piece of work and he confirms that again. The media has given a lot of coverage to a bloke called Charlie Mullins, founder of London's biggest independent plumbing company, Pimlico Plumbers, who has said he won't employ anyone who has not been vaccinated or have them go to any home where people are not vaccinated. He said that if he had his way no one would be allowed to walk the streets if they have not been vaccinated. Gates was cheering at the time while I was alerting the white coats. The plan is that people will qualify for 'passports' for having the first two doses and then to keep it they will have to have all the follow ups and new ones for invented 'variants' until human genetics is transformed and many are dead who can't adjust to the changes. Hollywood celebrities – the usual propaganda stunt – are promoting something called the WELL Health-Safety Rating to verify that a building or space has 'taken the necessary steps to prioritize the health and safety of their staff, visitors and other stakeholders'. They included Lady Gaga, Jennifer Lopez, Michael B. Jordan, Robert DeNiro, Venus Williams, Wolfgang Puck, Deepak Chopra and 17th Surgeon General Richard Carmona. Yawn. WELL Health-Safety has big connections with China. Parent company Delos is headed by former Goldman Sachs partner Paul Scialla. This is another example – and we will see so many others – of using the excuse of 'health' to dictate the lives and activities of the population. I guess one confirmation of the 'safety' of buildings is that only 'vaccinated' people can go in, right?

## **Electronic concentration camps**

I wrote decades ago about the plans to restrict travel and here we are for those who refuse to bow to tyranny. This can be achieved in one go with air travel if the aviation industry makes a blanket decree.

The 'vaccine' and guaranteed income are designed to be part of a global version of China's social credit system which tracks behaviour 24/7 and awards or deletes 'credits' based on whether your behaviour is supported by the state or not. I mean your entire lifestyle – what you do, eat, say, everything. Once your credit score falls below a certain level consequences kick in. In China tens of millions have been denied travel by air and train because of this. All the locations and activities denied to refusers by the 'vaccine' passports will be included in one big mass ban on doing almost anything for those that don't bow their head to government. It's beyond fascist and a new term is required to describe its extremes – I guess fascist technocracy will have to do. The way the Chinese system of technological – technocratic – control is sweeping the West can be seen in the Los Angeles school system and is planned to be expanded worldwide. Every child is required to have a 'Covid'-tracking app scanned daily before they can enter the classroom. The so-called Daily Pass tracking system is produced by Gates' Microsoft which I'm sure will shock you rigid. The pass will be scanned using a barcode (one step from an inside-the-body barcode) and the information will include health checks, 'Covid' tests and vaccinations. Entry codes are for one specific building only and access will only be allowed if a student or teacher has a negative test with a test not testing for the 'virus', has no symptoms of anything alleged to be related to 'Covid' (symptoms from a range of other illness), and has a temperature under 100 degrees. No barcode, no entry, is planned to be the case for everywhere and not only schools.

Kids are being psychologically prepared to accept this as 'normal' their whole life which is why what they can impose in schools is so important to the Cult and its gofers. Long-time American freedom campaigner John Whitehead of the Rutherford Institute was not exaggerating when he said: 'Databit by databit, we are building our own electronic concentration camps.' Canada under its Cult gofer prime minister Justin Trudeau has taken a major step towards the real thing with people interned against their will if they test positive with a test not testing for the 'virus' when they arrive at a Canadian

airport. They are jailed in internment hotels often without food or water for long periods and with many doors failing to lock there have been sexual assaults. The interned are being charged sometimes \$2,000 for the privilege of being abused in this way. Trudeau is fully on board with the Cult and says the 'Covid pandemic' has provided an opportunity for a global 'reset' to permanently change Western civilisation. His number two, Deputy Prime Minister Chrystia Freeland, is a trustee of the World Economic Forum and a Rhodes Scholar. The Trudeau family have long been servants of the Cult. See *The Biggest Secret* and Cathy O'Brien's book *Trance-Formation of America* for the horrific background to Trudeau's father Pierre Trudeau another Canadian prime minister. Hide your fascism behind the façade of a heart-on-the-sleeve liberal. It's a well-honed Cult technique.

### **What can the 'vaccine' really do?**

We have a 'virus' never shown to exist and 'variants' of the 'virus' that have also never been shown to exist except, like the 'original', as computer-generated fictions. Even if you believe there's a 'virus' the 'case' to 'death' rate is in the region of 0.23 to 0.15 percent and those 'deaths' are concentrated among the very old around the same average age that people die anyway. In response to this lack of threat (in truth none) psychopaths and idiots, knowingly and unknowingly answering to Gates and the Cult, are seeking to 'vaccinate' every man, woman and child on Planet Earth. Clearly the 'vaccine' is not about 'Covid' – none of this ever has been. So what is it all about *really*? Why the desperation to infuse genetically-manipulating synthetic material into everyone through mRNA fraudulent 'vaccines' with the intent of doing this over and over with the excuses of 'variants' and other 'virus' inventions? Dr Sherri Tenpenny, an osteopathic medical doctor in the United States, has made herself an expert on vaccines and their effects as a vehement campaigner against their use. Tenpenny was board certified in emergency medicine, the director of a level two trauma centre for 12 years, and moved to Cleveland in 1996 to start an integrative

medicine practice which has treated patients from all 50 states and some 17 other countries. Weaning people off pharmaceutical drugs is a speciality.

She became interested in the consequences of vaccines after attending a meeting at the National Vaccine Information Center in Washington DC in 2000 where she 'sat through four days of listening to medical doctors and scientists and lawyers and parents of vaccine injured kids' and asked: 'What's going on?' She had never been vaccinated and never got ill while her father was given a list of vaccines to be in the military and was 'sick his entire life'. The experience added to her questions and she began to examine vaccine documents from the Centers for Disease Control (CDC). After reading the first one, the 1998 version of *The General Recommendations of Vaccination*, she thought: 'This is it?' The document was poorly written and bad science and Tenpenny began 20 years of research into vaccines that continues to this day. She began her research into 'Covid vaccines' in March, 2020, and she describes them as 'deadly'. For many, as we have seen, they already have been. Tenpenny said that in the first 30 days of the 'vaccine' rollout in the United States there had been more than 40,000 adverse events reported to the vaccine adverse event database. A document had been delivered to her the day before that was 172 pages long. 'We have over 40,000 adverse events; we have over 3,100 cases of [potentially deadly] anaphylactic shock; we have over 5,000 neurological reactions.' Effects ranged from headaches to numbness, dizziness and vertigo, to losing feeling in hands or feet and paraesthesia which is when limbs 'fall asleep' and people have the sensation of insects crawling underneath their skin. All this happened in the first 30 days and remember that only about *ten percent* (or far less) of adverse reactions and vaccine-related deaths are estimated to be officially reported. Tenpenny said:

So can you think of one single product in any industry, any industry, for as long as products have been made on the planet that within 30 days we have 40,000 people complaining of side effects that not only is still on the market but ... we've got paid actors telling us how great

they are for getting their vaccine. We're offering people \$500 if they will just get their vaccine and we've got nurses and doctors going; 'I got the vaccine, I got the vaccine'.

Tenpenny said they were not going to be 'happy dancing folks' when they began to suffer Bell's palsy (facial paralysis), neuropathies, cardiac arrhythmias and autoimmune reactions that kill through a blood disorder. 'They're not going to be so happy, happy then, but we're never going to see pictures of those people' she said. Tenpenny described the 'vaccine' as 'a well-designed killing tool'.

## **No off-switch**

Bad as the initial consequences had been Tenpenny said it would be maybe 14 months before we began to see the 'full ravage' of what is going to happen to the 'Covid vaccinated' with full-out consequences taking anything between two years and 20 years to show. You can understand why when you consider that variations of the 'Covid vaccine' use mRNA (messenger RNA) to in theory activate the immune system to produce protective antibodies without using the actual 'virus'. How can they when it's a computer program and they've never isolated what they claim is the 'real thing'? Instead they use *synthetic* mRNA. They are inoculating synthetic material into the body which through a technique known as the Trojan horse is absorbed into cells to change the nature of DNA. Human DNA is changed by an infusion of messenger RNA and with each new 'vaccine' of this type it is changed even more. Say so and you are banned by Cult Internet platforms. The contempt the contemptuous Mark Zuckerberg has for the truth and human health can be seen in an internal Facebook video leaked to the Project Veritas investigative team in which he said of the 'Covid vaccines': '... I share some caution on this because we just don't know the long term side-effects of basically modifying people's DNA and RNA.' At the same time this disgusting man's Facebook was censoring and banning anyone saying exactly the same. He must go before a Nuremberg trial for crimes against humanity when he *knows* that he



is censoring legitimate concerns and denying the right of informed consent on behalf of the Cult that owns him. People have been killed and damaged by the very 'vaccination' technique he cast doubt on himself when they may not have had the 'vaccine' with access to information that he denied them. The plan is to have at least annual 'Covid vaccinations', add others to deal with invented 'variants', and change all other vaccines into the mRNA system. Pfizer executives told shareholders at a virtual Barclays Global Healthcare Conference in March, 2021, that the public may need a third dose of 'Covid vaccine', plus regular yearly boosters and the company planned to hike prices to milk the profits in a 'significant opportunity for our vaccine'. These are the professional liars, cheats and opportunists who are telling you their 'vaccine' is safe. Given this volume of mRNA planned to be infused into the human body and its ability to then replicate we will have a transformation of human genetics from biological to synthetic biological – exactly the long-time Cult plan for reasons we'll see – and many will die. Sherri Tenpenny said of this replication:

It's like having an on-button but no off-button and that whole mechanism ... they actually give it a name and they call it the Trojan horse mechanism, because it allows that [synthetic] virus and that piece of that [synthetic] virus to get inside of your cells, start to replicate and even get inserted into other parts of your DNA as a Trojan-horse.

Ask the overwhelming majority of people who have the 'vaccine' what they know about the contents and what they do and they would reply: 'The government says it will stop me getting the virus.' Governments give that false impression on purpose to increase take-up. You can read Sherri Tenpenny's detailed analysis of the health consequences in her blog at [Vaxxter.com](https://www.vaxxter.com), but in summary these are some of them. She highlights the statement by Bill Gates about how human beings can become their own 'vaccine manufacturing machine'. The man is insane. ['Vaccine'-generated] 'antibodies' carry synthetic messenger RNA into the cells and the damage starts, Tenpenny contends, and she says that lungs can be adversely affected through varying degrees of pus and bleeding which

obviously affects breathing and would be dubbed 'Covid-19'. Even more sinister was the impact of 'antibodies' on macrophages, a white blood cell of the immune system. They consist of Type 1 and Type 2 which have very different functions. She said Type 1 are 'hyper-vigilant' white blood cells which 'gobble up' bacteria etc. However, in doing so, this could cause inflammation and in extreme circumstances be fatal. She says these affects are mitigated by Type 2 macrophages which kick in to calm down the system and stop it going rogue. They clear up dead tissue debris and reduce inflammation that the Type 1 'fire crews' have caused. Type 1 kills the infection and Type 2 heals the damage, she says. This is her punchline with regard to 'Covid vaccinations': She says that mRNA 'antibodies' block Type 2 macrophages by attaching to them and deactivating them. This meant that when the Type 1 response was triggered by infection there was nothing to stop that getting out of hand by calming everything down. There's an on-switch, but no off-switch, she says. What follows can be 'over and out, see you when I see you'.

## **Genetic suicide**

Tenpenny also highlights the potential for autoimmune disease – the body attacking itself – which has been associated with vaccines since they first appeared. Infusing a synthetic foreign substance into cells could cause the immune system to react in a panic believing that the body is being overwhelmed by an invader (it is) and the consequences can again be fatal. There is an autoimmune response known as a 'cytokine storm' which I have likened to a homeowner panicked by an intruder and picking up a gun to shoot randomly in all directions before turning the fire on himself. The immune system unleashes a storm of inflammatory response called cytokines to a threat and the body commits hara-kiri. The lesson is that you mess with the body's immune response at your peril and these 'vaccines' seriously – fundamentally – mess with immune response. Tenpenny refers to a consequence called anaphylactic shock which is a severe and highly dangerous allergic reaction when the immune system

floods the body with chemicals. She gives the example of having a bee sting which primes the immune system and makes it sensitive to those chemicals. When people are stung again maybe years later the immune response can be so powerful that it leads to anaphylactic shock. Tenpenny relates this 'shock' with regard to the 'Covid vaccine' to something called polyethylene glycol or PEG. Enormous numbers of people have become sensitive to this over decades of use in a whole range of products and processes including food, drink, skin creams and 'medicine'. Studies have claimed that some 72 percent of people have antibodies triggered by PEG compared with two percent in the 1960s and allergic hypersensitive reactions to this become a gathering cause for concern. Tenpenny points out that the 'mRNA vaccine' is coated in a 'bubble' of polyethylene glycol which has the potential to cause anaphylactic shock through immune sensitivity. Many reports have appeared of people reacting this way after having the 'Covid vaccine'. What do we think is going to happen as humanity has more and more of these 'vaccines'?

Tenpenny said: 'All these pictures we have seen with people with these rashes ... these weepy rashes, big reactions on their arms and things like that – it's an acute allergic reaction most likely to the polyethylene glycol that you've been previously primed and sensitised to.'

Those who have not studied the conspiracy and its perpetrators at length might think that making the population sensitive to PEG and then putting it in these 'vaccines' is just a coincidence. It is not. It is instead testament to how carefully and coldly-planned current events have been and the scale of the conspiracy we are dealing with. Tenpenny further explains that the 'vaccine' mRNA procedure can breach the blood-brain barrier which protects the brain from toxins and other crap that will cause malfunction. In this case they could make two proteins corrupt brain function to cause Amyotrophic lateral sclerosis (ALS), a progressive nervous system disease leading to loss of muscle control, and frontal lobe degeneration – Alzheimer's and dementia. Immunologist J. Bart Classon published a paper connecting mRNA 'vaccines' to prion

disease which can lead to Alzheimer's and other forms of neurodegenerative disease while others have pointed out the potential to affect the placenta in ways that make women infertile. This will become highly significant in the next chapter when I will discuss other aspects of this non-vaccine that relate to its nanotechnology and transmission from the injected to the uninjected.

## **Qualified in idiocy**

Tenpenny describes how research has confirmed that these 'vaccine'-generated antibodies can interact with a range of other tissues in the body and attack many other organs including the lungs. 'This means that if you have a hundred people standing in front of you that all got this shot they could have a hundred different symptoms.'

Anyone really think that Cult gofers like the Queen, Tony Blair, Christopher Whitty, Anthony Fauci, and all the other psychopaths have really had this 'vaccine' in the pictures we've seen? Not a bloody chance. Why don't doctors all tell us about all these dangers and consequences of the 'Covid vaccine'? Why instead do they encourage and pressure patients to have the shot? Don't let's think for a moment that doctors and medical staff can't be stupid, lazy, and psychopathic and that's without the financial incentives to give the jab. Tenpenny again:

Some people are going to die from the vaccine directly but a large number of people are going to start to get horribly sick and get all kinds of autoimmune diseases 42 days to maybe a year out. What are they going to do, these stupid doctors who say; 'Good for you for getting that vaccine.' What are they going to say; 'Oh, it must be a mutant, we need to give an extra dose of that vaccine.'

Because now the vaccine, instead of one dose or two doses we need three or four because the stupid physicians aren't taking the time to learn anything about it. If I can learn this sitting in my living room reading a 19 page paper and several others so can they. There's nothing special about me, I just take the time to do it.

Remember how Sara Kayat, the NHS and TV doctor, said that the 'Covid vaccine' would '100 percent prevent hospitalisation and death'. Doctors can be idiots like every other profession and they

should not be worshipped as infallible. They are not and far from it. Behind many medical and scientific 'experts' lies an uninformed prat trying to hide themselves from you although in the 'Covid' era many have failed to do so as with UK narrative-repeating 'TV doctor' Hilary Jones. Pushing back against the minority of proper doctors and scientists speaking out against the 'vaccine' has been the entire edifice of the Cult global state in the form of governments, medical systems, corporations, mainstream media, Silicon Valley, and an army of compliant doctors, medical staff and scientists willing to say anything for money and to enhance their careers by promoting the party line. If you do that you are an 'expert' and if you won't you are an 'anti-vaxxer' and 'Covidiot'. The pressure to be 'vaccinated' is incessant. We have even had reports claiming that the 'vaccine' can help cure cancer and Alzheimer's and make the lame walk. I am waiting for the announcement that it can bring you coffee in the morning and cook your tea. Just as the symptoms of 'Covid' seem to increase by the week so have the miracles of the 'vaccine'. American supermarket giant Kroger Co. offered nearly 500,000 employees in 35 states a \$100 bonus for having the 'vaccine' while donut chain Krispy Kreme promised 'vaccinated' customers a free glazed donut every day for the rest of 2021. Have your DNA changed and you will get a doughnut although we might not have to give you them for long. Such offers and incentives confirm the desperation.

Perhaps the worse vaccine-stunt of them all was UK 'Health' Secretary Matt-the-prat Hancock on live TV after watching a clip of someone being 'vaccinated' when the roll-out began. Hancock faked tears so badly it was embarrassing. Brain-of-Britain Piers Morgan, the lockdown-supporting, 'vaccine' supporting, 'vaccine' passport-supporting, TV host played along with Hancock – 'You're quite emotional about that' he said in response to acting so atrocious it would have been called out at a school nativity which will presumably today include Mary and Jesus in masks, wise men keeping their camels six feet apart, and shepherds under tent arrest. System-serving Morgan tweeted this: 'Love the idea of covid vaccine passports for everywhere: flights, restaurants, clubs, football, gyms,

shops etc. It's time covid-denying, anti-vaxxer loonies had their bullsh\*t bluff called & bar themselves from going anywhere that responsible citizens go.' If only I could aspire to his genius. To think that Morgan, who specialises in shouting over anyone he disagrees with, was lauded as a free speech hero when he lost his job after storming off the set of his live show like a child throwing his dolly out of the pram. If he is a free speech hero we are in real trouble. I have no idea what 'bullsh\*t' means, by the way, the \* throws me completely.

The Cult is desperate to infuse its synthetic DNA-changing concoction into everyone and has been using every lie, trick and intimidation to do so. The question of '*Why?*' we shall now address.

## CHAPTER TEN

### Human 2.0

*I believe that at the end of the century the use of words and general educated opinion will have altered so much that one will be able to speak of machines thinking without expecting to be contradicted – Alan Turing (1912-1954), the ‘Father of artificial intelligence’*

I have been exposing for decades the plan to transform the human body from a biological to a synthetic-biological state. The new human that I will call Human 2.0 is planned to be connected to artificial intelligence and a global AI ‘Smart Grid’ that would operate as one global system in which AI would control everything from your fridge to your heating system to your car to your mind. Humans would no longer be ‘human’, but post-human and sub-human, with their thinking and emotional processes replaced by AI.

What I said sounded crazy and beyond science fiction and I could understand that. To any balanced, rational, mind it *is* crazy. Today, however, that world is becoming reality and it puts the ‘Covid vaccine’ into its true context. Ray Kurzweil is the ultra-Zionist ‘computer scientist, inventor and futurist’ and co-founder of the Singularity University. Singularity refers to the merging of humans with machines or ‘transhumanism’. Kurzweil has said humanity would be connected to the cyber ‘cloud’ in the period of the ever-recurring year of 2030:

Our thinking ... will be a hybrid of biological and non-biological thinking ... humans will be able to extend their limitations and ‘think in the cloud’ ... We’re going to put gateways to the

cloud in our brains ... We're going to gradually merge and enhance ourselves ... In my view, that's the nature of being human – we transcend our limitations. As the technology becomes vastly superior to what we are then the small proportion that is still human gets smaller and smaller and smaller until it's just utterly negligible.

They are trying to sell this end-of-humanity-as-we-know-it as the next stage of 'evolution' when we become super-human and 'like the gods'. They are lying to you. Shocked, eh? The population, and again especially the young, have been manipulated into addiction to technologies designed to enslave them for life. First they induced an addiction to smartphones (holdables); next they moved to technology on the body (wearables); and then began the invasion of the body (implantables). I warned way back about the plan for microchipped people and we are now entering that era. We should not be diverted into thinking that this refers only to chips we can see. Most important are the nanochips known as smart dust, neural dust and nanobots which are far too small to be seen by the human eye. Nanotechnology is everywhere, increasingly in food products, and released into the atmosphere by the geoengineering of the skies funded by Bill Gates to 'shut out the Sun' and 'save the planet from global warming'. Gates has been funding a project to spray millions of tonnes of chalk (calcium carbonate) into the stratosphere over Sweden to 'dim the Sun' and cool the Earth. Scientists warned the move could be disastrous for weather systems in ways no one can predict and opposition led to the Swedish space agency announcing that the 'experiment' would not be happening as planned in the summer of 2021; but it shows where the Cult is going with dimming the impact of the Sun and there's an associated plan to change the planet's atmosphere. Who gives psychopath Gates the right to dictate to the entire human race and dismantle planetary systems? The world will not be safe while this man is at large.

The global warming hoax has made the Sun, like the gas of life, something to fear when both are essential to good health and human survival (more inversion). The body transforms sunlight into vital vitamin D through a process involving ... *cholesterol*. This is the cholesterol we are also told to fear. We are urged to take Big Pharma



statin drugs to reduce cholesterol and it's all systematic. Reducing cholesterol means reducing vitamin D uptake with all the multiple health problems that will cause. At least if you take statins long term it saves the government from having to pay you a pension. The delivery system to block sunlight is widely referred to as chemtrails although these have a much deeper agenda, too. They appear at first to be contrails or condensation trails streaming from aircraft into cold air at high altitudes. Contrails disperse very quickly while chemtrails do not and spread out across the sky before eventually their content falls to earth. Many times I have watched aircraft cross-cross a clear blue sky releasing chemtrails until it looks like a cloudy day. Chemtrails contain many things harmful to humans and the natural world including toxic heavy metals, aluminium (see Alzheimer's) and nanotechnology. Ray Kurzweil reveals the reason without actually saying so: 'Nanobots will infuse all the matter around us with information. Rocks, trees, everything will become these intelligent creatures.' How do you deliver that? *From the sky*. Self-replicating nanobots would connect everything to the Smart Grid. The phenomenon of Morgellons disease began in the chemtrail era and the correlation has led to it being dubbed the 'chemtrail disease'. Self-replicating fibres appear in the body that can be pulled out through the skin. Morgellons fibres continue to grow outside the body and have a form of artificial intelligence. I cover this at greater length in *Phantom Self*.

### **'Vaccine' operating system**

'Covid vaccines' with their self-replicating synthetic material are also designed to make the connection between humanity and Kurzweil's 'cloud'. American doctor and dedicated campaigner for truth, Carrie Madej, an Internal Medicine Specialist in Georgia with more than 20 years medical experience, has highlighted the nanotechnology aspect of the fake 'vaccines'. She explains how one of the components in at least the Moderna and Pfizer synthetic potions are 'lipid nanoparticles' which are 'like little tiny computer bits' – a 'sci-fi substance' known as nanobots and hydrogel which can be 'triggered

at any moment to deliver its payload' and act as 'biosensors'. The synthetic substance had 'the ability to accumulate data from your body like your breathing, your respiration, thoughts and emotions, all kind of things' and each syringe could carry a *million* nanobots:

This substance because it's like little bits of computers in your body, crazy, but it's true, it can do that, [and] obviously has the ability to act through Wi-Fi. It can receive and transmit energy, messages, frequencies or impulses. That issue has never been addressed by these companies. What does that do to the human?

Just imagine getting this substance in you and it can react to things all around you, the 5G, your smart device, your phones, what is happening with that? What if something is triggering it, too, like an impulse, a frequency? We have something completely foreign in the human body.

Madej said her research revealed that electromagnetic (EMF) frequencies emitted by phones and other devices had increased dramatically in the same period of the 'vaccine' rollout and she was seeing more people with radiation problems as 5G and other electromagnetic technology was expanded and introduced to schools and hospitals. She said she was 'floored with the EMF coming off' the devices she checked. All this makes total sense and syncs with my own work of decades when you think that Moderna refers in documents to its mRNA 'vaccine' as an 'operating system':

Recognizing the broad potential of mRNA science, we set out to create an mRNA technology platform that functions very much like an operating system on a computer. It is designed so that it can plug and play interchangeably with different programs. In our case, the 'program' or 'app' is our mRNA drug – the unique mRNA sequence that codes for a protein ...

... Our MRNA Medicines – 'The 'Software Of Life': When we have a concept for a new mRNA medicine and begin research, fundamental components are already in place. Generally, the only thing that changes from one potential mRNA medicine to another is the coding region – the actual genetic code that instructs ribosomes to make protein. Utilizing these instruction sets gives our investigational mRNA medicines a software-like quality. We also have the ability to combine different mRNA sequences encoding for different proteins in a single mRNA investigational medicine.

Who needs a real 'virus' when you can create a computer version to justify infusing your operating system into the entire human race on the road to making living, breathing people into cyborgs? What is missed with the 'vaccines' is the *digital* connection between synthetic material and the body that I highlighted earlier with the study that hacked a computer with human DNA. On one level the body is digital, based on mathematical codes, and I'll have more about that in the next chapter. Those who ridiculously claim that mRNA 'vaccines' are not designed to change human genetics should explain the words of Dr Tal Zaks, chief medical officer at Moderna, in a 2017 TED talk. He said that over the last 30 years 'we've been living this phenomenal digital scientific revolution, and I'm here today to tell you, that we are actually *hacking the software of life*, and that it's changing the way we think about prevention and treatment of disease':

In every cell there's this thing called messenger RNA, or mRNA for short, that transmits the critical information from the DNA in our genes to the protein, which is really the stuff we're all made out of. This is the critical information that determines what the cell will do. So we think about it as an operating system. So if you could change that, if you could introduce a line of code, or change a line of code, it turns out, that has profound implications for everything, from the flu to cancer.

Zaks should more accurately have said that this has profound implications for the human genetic code and the nature of DNA. Communications within the body go both ways and not only one. But, hey, no, the 'Covid vaccine' will not affect your genetics. Cult fact-checkers say so even though the man who helped to develop the mRNA technique says that it does. Zaks said in 2017:

If you think about what it is we're trying to do. We've taken information and our understanding of that information and how that information is transmitted in a cell, and we've taken our understanding of medicine and how to make drugs, and we're fusing the two. We think of it as information therapy.

I have been writing for decades that the body is an information field communicating with itself and the wider world. This is why

radiation which is information can change the information field of body and mind through phenomena like 5G and change their nature and function. 'Information therapy' means to change the body's information field and change the way it operates. DNA is a receiver-transmitter of information and can be mutated by information like mRNA synthetic messaging. Technology to do this has been ready and waiting in the underground bases and other secret projects to be rolled out when the 'Covid' hoax was played. 'Trials' of such short and irrelevant duration were only for public consumption. When they say the 'vaccine' is 'experimental' that is not true. It may appear to be 'experimental' to those who don't know what's going on, but the trials have already been done to ensure the Cult gets the result it desires. Zaks said that it took decades to sequence the human genome, completed in 2003, but now they could do it in a week. By 'they' he means scientists operating in the public domain. In the secret projects they were sequencing the genome in a week long before even 2003.

## **Deluge of mRNA**

Highly significantly the Moderna document says the guiding premise is that if using mRNA as a medicine works for one disease then it should work for many diseases. They were leveraging the flexibility afforded by their platform and the fundamental role mRNA plays in protein synthesis to pursue mRNA medicines for a broad spectrum of diseases. Moderna is confirming what I was saying through 2020 that multiple 'vaccines' were planned for 'Covid' (and later invented 'variants') and that previous vaccines would be converted to the mRNA system to infuse the body with massive amounts of genetically-manipulating synthetic material to secure a transformation to a synthetic-biological state. The 'vaccines' are designed to kill stunning numbers as part of the long-exposed Cult depopulation agenda and transform the rest. Given this is the goal you can appreciate why there is such hysterical demand for every human to be 'vaccinated' for an alleged 'disease' that has an estimated 'infection' to 'death' ratio of 0.23-0.15 percent. As I write

children are being given the 'vaccine' in trials (their parents are a disgrace) and ever-younger people are being offered the vaccine for a 'virus' that even if you believe it exists has virtually zero chance of harming them. Horrific effects of the 'trials' on a 12-year-old girl were revealed by a family member to be serious brain and gastric problems that included a bowel obstruction and the inability to swallow liquids or solids. She was unable to eat or drink without throwing up, had extreme pain in her back, neck and abdomen, and was paralysed from the waist down which stopped her urinating unaided. When the girl was first taken to hospital doctors said it was all in her mind. She was signed up for the 'trial' by her parents for whom no words suffice. None of this 'Covid vaccine' insanity makes any sense unless you see what the 'vaccine' really is – a body-changer. Synthetic biology or 'SynBio' is a fast-emerging and expanding scientific discipline which includes everything from genetic and molecular engineering to electrical and computer engineering. Synthetic biology is defined in these ways:

- A multidisciplinary area of research that seeks to create new biological parts, devices, and systems, or to redesign systems that are already found in nature.
- The use of a mixture of physical engineering and genetic engineering to create new (and therefore synthetic) life forms.
- An emerging field of research that aims to combine the knowledge and methods of biology, engineering and related disciplines in the design of chemically-synthesized DNA to create organisms with novel or enhanced characteristics and traits (synthetic organisms including humans).

We now have synthetic blood, skin, organs and limbs being developed along with synthetic body parts produced by 3D printers. These are all elements of the synthetic human programme and this comment by Kurzweil's co-founder of the Singularity University,

Peter Diamandis, can be seen in a whole new light with the 'Covid' hoax and the sanctions against those that refuse the 'vaccine':

Anybody who is going to be resisting the progress forward [to transhumanism] is going to be resisting evolution and, fundamentally, they will die out. It's not a matter of whether it's good or bad. It's going to happen.

'Resisting evolution'? What absolute bollocks. The arrogance of these people is without limit. His 'it's going to happen' mantra is another way of saying 'resistance is futile' to break the spirit of those pushing back and we must not fall for it. Getting this genetically-transforming 'vaccine' into everyone is crucial to the Cult plan for total control and the desperation to achieve that is clear for anyone to see. Vaccine passports are a major factor in this and they, too, are a form of resistance is futile. It's NOT. The paper funded by the Rockefeller Foundation for the 2013 'health conference' in China said:

We will interact more with artificial intelligence. The use of robotics, bio-engineering to augment human functioning is already well underway and will advance. Re-engineering of humans into potentially separate and unequal forms through genetic engineering or mixed human-robots raises debates on ethics and equality.

A new demography is projected to emerge after 2030 [that year again] of technologies (robotics, genetic engineering, nanotechnology) producing robots, engineered organisms, 'nanobots' and artificial intelligence (AI) that can self-replicate. Debates will grow on the implications of an impending reality of human designed life.

What is happening today is so long planned. The world army enforcing the will of the world government is intended to be a robot army, not a human one. Today's military and its technologically 'enhanced' troops, pilotless planes and driverless vehicles are just stepping stones to that end. Human soldiers are used as Cult fodder and its time they woke up to that and worked for the freedom of the population instead of their own destruction and their family's destruction – the same with the police. Join us and let's sort this out. The phenomenon of enforce my own destruction is widespread in the 'Covid' era with Woker 'luvvies' in the acting and entertainment

industries supporting 'Covid' rules which have destroyed their profession and the same with those among the public who put signs on the doors of their businesses 'closed due to Covid – stay safe' when many will never reopen. It's a form of masochism and most certainly insanity.

## **Transgender = transhumanism**

When something explodes out of nowhere and is suddenly everywhere it is always the Cult agenda and so it is with the tidal wave of claims and demands that have infiltrated every aspect of society under the heading of 'transgenderism'. The term 'trans' is so 'in' and this is the dictionary definition:

A prefix meaning 'across', 'through', occurring ... in loanwords from Latin, used in particular for denoting movement or conveyance from place to place (transfer; transmit; transplant) or complete change (transform; transmute), or to form adjectives meaning 'crossing', 'on the other side of', or 'going beyond' the place named (transmontane; transnational; trans-Siberian).

Transgender means to go beyond gender and transhuman means to go beyond human. Both are aspects of the Cult plan to transform the human body to a synthetic state with *no gender*. Human 2.0 is not designed to procreate and would be produced technologically with no need for parents. The new human would mean the end of parents and so men, and increasingly women, are being targeted for the deletion of their rights and status. Parental rights are disappearing at an ever-quickenning speed for the same reason. The new human would have no need for men or women when there is no procreation and no gender. Perhaps the transgender movement that appears to be in a permanent state of frenzy might now contemplate on how it is being used. This was never about transgender rights which are only the interim excuse for confusing gender, particularly in the young, on the road to *fusing* gender. Transgender activism is not an end; it is a *means* to an end. We see again the technique of creative destruction in which you destroy the status quo to 'build back better' in the form that you want. The gender status quo had to be

destroyed by persuading the Cult-created Woke mentality to believe that you can have 100 genders or more. A programme for 9 to 12 year olds produced by the Cult-owned BBC promoted the 100 genders narrative. The very idea may be the most monumental nonsense, but it is not what is true that counts, only what you can make people *believe* is true. Once the gender of  $2 + 2 = 4$  has been dismantled through indoctrination, intimidation and  $2 + 2 = 5$  then the new no-gender normal can take its place with Human 2.0.

Aldous Huxley revealed the plan in his prophetic *Brave New World* in 1932:

Natural reproduction has been done away with and children are created, decanted', and raised in 'hatcheries and conditioning centres'. From birth, people are genetically designed to fit into one of five castes, which are further split into 'Plus' and 'Minus' members and designed to fulfil predetermined positions within the social and economic strata of the World State.

How could Huxley know this in 1932? For the same reason George Orwell knew about the Big Brother state in 1948, Cult insiders I have quoted knew about it in 1969, and I have known about it since the early 1990s. If you are connected to the Cult or you work your balls off to uncover the plan you can predict the future. The process is simple. If there is a plan for the world and nothing intervenes to stop it then it will happen. Thus if you communicate the plan ahead of time you are perceived to have predicted the future, but you haven't. You have revealed the plan which without intervention will become the human future. The whole reason I have done what I have is to alert enough people to inspire an intervention and maybe at last that time has come with the Cult and its intentions now so obvious to anyone with a brain in working order.

## **The future is here**

Technological wombs that Huxley described to replace parent procreation are already being developed and they are only the projects we know about in the public arena. Israeli scientists told *The Times of Israel* in March, 2021, that they have grown 250-cell embryos



into mouse fetuses with fully formed organs using artificial wombs in a development they say could pave the way for gestating humans outside the womb. Professor Jacob Hanna of the Weizmann Institute of Science said:

We took mouse embryos from the mother at day five of development, when they are just of 250 cells, and had them in the incubator from day five until day 11, by which point they had grown all their organs.

By day 11 they make their own blood and have a beating heart, a fully developed brain. Anybody would look at them and say, 'this is clearly a mouse foetus with all the characteristics of a mouse.' It's gone from being a ball of cells to being an advanced foetus.

A special liquid is used to nourish embryo cells in a laboratory dish and they float on the liquid to duplicate the first stage of embryonic development. The incubator creates all the right conditions for its development, Hanna said. The liquid gives the embryo 'all the nutrients, hormones and sugars they need' along with a custom-made electronic incubator which controls gas concentration, pressure and temperature. The cutting-edge in the underground bases and other secret locations will be light years ahead of that, however, and this was reported by the London *Guardian* in 2017:

We are approaching a biotechnological breakthrough. Ectogenesis, the invention of a complete external womb, could completely change the nature of human reproduction. In April this year, researchers at the Children's Hospital of Philadelphia announced their development of an artificial womb.

The article was headed 'Artificial wombs could soon be a reality. What will this mean for women?' What would it mean for children is an even bigger question. No mother to bond with only a machine in preparation for a life of soulless interaction and control in a world governed by machines (see the *Matrix* movies). Now observe the calculated manipulations of the 'Covid' hoax as human interaction and warmth has been curtailed by distancing, isolation and fear with people communicating via machines on a scale never seen before.

These are all dots in the same picture as are all the personal assistants, gadgets and children's toys through which kids and adults communicate with AI as if it is human. The AI 'voice' on Sat-Nav should be included. All these things are psychological preparation for the Cult endgame. Before you can make a physical connection with AI you have to make a psychological connection and that is what people are being conditioned to do with this ever gathering human-AI interaction. Movies and TV programmes depicting the transhuman, robot dystopia relate to a phenomenon known as 'pre-emptive programming' in which the world that is planned is portrayed everywhere in movies, TV and advertising. This is conditioning the conscious and subconscious mind to become familiar with the planned reality to dilute resistance when it happens for real. What would have been a shock such is the change is made less so. We have young children put on the road to transgender transition surgery with puberty blocking drugs at an age when they could never be able to make those life-changing decisions.

Rachel Levine, a professor of paediatrics and psychiatry who believes in treating children this way, became America's highest-ranked openly-transgender official when she was confirmed as US Assistant Secretary at the Department of Health and Human Services after being nominated by Joe Biden (the Cult). Activists and governments press for laws to deny parents a say in their children's transition process so the kids can be isolated and manipulated into agreeing to irreversible medical procedures. A Canadian father Robert Hoogland was denied bail by the Vancouver Supreme Court in 2021 and remained in jail for breaching a court order that he stay silent over his young teenage daughter, a minor, who was being offered life-changing hormone therapy without parental consent. At the age of 12 the girl's 'school counsellor' said she may be transgender, referred her to a doctor and told the school to treat her like a boy. This is another example of state-serving schools imposing ever more control over children's lives while parents have ever less.

Contemptible and extreme child abuse is happening all over the world as the Cult gender-fusion operation goes into warp-speed.

### **Why the war on men – and now women?**

The question about what artificial wombs mean for women should rightly be asked. The answer can be seen in the deletion of women's rights involving sport, changing rooms, toilets and status in favour of people in male bodies claiming to identify as women. I can identify as a mountain climber, but it doesn't mean I can climb a mountain any more than a biological man can be a biological woman. To believe so is a triumph of belief over factual reality which is the very perceptual basis of everything Woke. Women's sport is being destroyed by allowing those with male bodies who say they identify as female to 'compete' with girls and women. Male body 'women' dominate 'women's' competition with their greater muscle mass, bone density, strength and speed. With that disadvantage sport for women loses all meaning. To put this in perspective nearly 300 American high school boys can run faster than the quickest woman sprinter in the world. Women are seeing their previously protected spaces invaded by male bodies simply because they claim to identify as women. That's all they need to do to access all women's spaces and activities under the Biden 'Equality Act' that destroys equality for women with the usual Orwellian Woke inversion. Male sex offenders have already committed rapes in women's prisons after claiming to identify as women to get them transferred. Does this not matter to the Woke 'equality' hypocrites? Not in the least. What matters to Cult manipulators and funders behind transgender activists is to advance gender fusion on the way to the no-gender 'human'. When you are seeking to impose transparent nonsense like this, or the 'Covid' hoax, the only way the nonsense can prevail is through censorship and intimidation of dissenters, deletion of factual information, and programming of the unquestioning, bewildered and naive. You don't have to scan the world for long to see that all these things are happening.

Many women's rights organisations have realised that rights and status which took such a long time to secure are being eroded and that it is systematic. Kara Dansky of the global Women's Human Rights Campaign said that Biden's transgender executive order immediately he took office, subsequent orders, and Equality Act legislation that followed 'seek to erase women and girls in the law as a category'. *Exactly*. I said during the long ago-started war on men (in which many women play a crucial part) that this was going to turn into a war on them. The Cult is phasing out *both* male and female genders. To get away with that they are brought into conflict so they are busy fighting each other while the Cult completes the job with no unity of response. Unity, people, *unity*. We need unity everywhere. Transgender is the only show in town as the big step towards the no-gender human. It's not about rights for transgender people and never has been. Woke political correctness is deleting words relating to genders to the same end. Wokers believe this is to be 'inclusive' when the opposite is true. They are deleting words describing gender because gender *itself* is being deleted by Human 2.0. Terms like 'man', 'woman', 'mother' and 'father' are being deleted in the universities and other institutions to be replaced by the *no-gender*, not trans-gender, 'individuals' and 'guardians'. Women's rights campaigner Maria Keffler of Partners for Ethical Care said: 'Children are being taught from kindergarten upward that some boys have a vagina, some girls have a penis, and that kids can be any gender they want to be.' Do we really believe that suddenly countries all over the world at the same time had the idea of having drag queens go into schools or read transgender stories to very young children in the local library? It's coldly-calculated confusion of gender on the way to the fusion of gender. Suzanne Vierling, a psychologist from Southern California, made another important point:

Yesterday's slave woman who endured gynecological medical experiments is today's girl-child being butchered in a booming gender-transitioning sector. Ovaries removed, pushing her into menopause and osteoporosis, uncharted territory, and parents' rights and authority decimated.

The erosion of parental rights is a common theme in line with the Cult plans to erase the very concept of parents and 'ovaries removed, pushing her into menopause' means what? Those born female lose the ability to have children – another way to discontinue humanity as we know it.

### **Eliminating Human 1.0 (before our very eyes)**

To pave the way for Human 2.0 you must phase out Human 1.0. This is happening through plummeting sperm counts and making women infertile through an onslaught of chemicals, radiation (including smartphones in pockets of men) and mRNA 'vaccines'. Common agriculture pesticides are also having a devastating impact on human fertility. I have been tracking collapsing sperm counts in the books for a long time and in 2021 came a book by fertility scientist and reproductive epidemiologist Shanna Swan, *Count Down: How Our Modern World Is Threatening Sperm Counts, Altering Male and Female Reproductive Development and Imperiling the Future of the Human Race*. She reports how the global fertility rate dropped by *half* between 1960 and 2016 with America's birth rate 16 percent below where it needs to be to sustain the population. Women are experiencing declining egg quality, more miscarriages, and more couples suffer from infertility. Other findings were an increase in erectile dysfunction, infant boys developing more genital abnormalities, male problems with conception, and plunging levels of the male hormone testosterone which would explain why so many men have lost their backbone and masculinity. This has been very evident during the 'Covid' hoax when women have been prominent among the Pushbackers and big strapping blokes have bowed their heads, covered their faces with a nappy and quietly submitted. Mind control expert Cathy O'Brien also points to how global education introduced the concept of 'we're all winners' in sport and classrooms: 'Competition was defused, and it in turn defused a sense of fighting back.' This is another version of the 'equity' doctrine in which you drive down rather than raise up. What a contrast in Cult-controlled China with its global ambitions

where the government published plans in January, 2021, to 'cultivate masculinity' in boys from kindergarten through to high school in the face of a 'masculinity crisis'. A government adviser said boys would be soon become 'delicate, timid and effeminate' unless action was taken. Don't expect any similar policy in the targeted West. A 2006 study showed that a 65-year-old man in 2002 had testosterone levels *15 percent* lower than a 65-year-old man in 1987 while a 2020 study found a similar story with young adults and adolescents. Men are getting prescriptions for testosterone replacement therapy which causes an even greater drop in sperm count with up to 99 percent seeing sperm counts drop to zero during the treatment. More sperm is defective and malfunctioning with some having two heads or not pursuing an egg.

A class of *synthetic* chemicals known as phthalates are being blamed for the decline. These are found everywhere in plastics, shampoos, cosmetics, furniture, flame retardants, personal care products, pesticides, canned foods and even receipts. Why till receipts? Everyone touches them. Let no one delude themselves that all this is not systematic to advance the long-time agenda for human body transformation. Phthalates mimic hormones and disrupt the hormone balance causing testosterone to fall and genital birth defects in male infants. Animals and fish have been affected in the same way due to phthalates and other toxins in rivers. When fish turn gay or change sex through chemicals in rivers and streams it is a pointer to why there has been such an increase in gay people and the sexually confused. It doesn't matter to me what sexuality people choose to be, but if it's being affected by chemical pollution and consumption then we need to know. Does anyone really think that this is not connected to the transgender agenda, the war on men and the condemnation of male 'toxic masculinity'? You watch this being followed by 'toxic femininity'. It's already happening. When breastfeeding becomes 'chest-feeding', pregnant women become pregnant people along with all the other Woke claptrap you know that the world is going insane and there's a Cult scam in progress. Transgender activists are promoting the Cult agenda while Cult

billionaires support and fund the insanity as they laugh themselves to sleep at the sheer stupidity for which humans must be infamous in galaxies far, far away.

### **'Covid vaccines' and female infertility**

We can now see why the 'vaccine' has been connected to potential infertility in women. Dr Michael Yeadon, former Vice President and Chief Scientific Advisor at Pfizer, and Dr Wolfgang Wodarg in Germany, filed a petition with the European Medicines Agency in December, 2020, urging them to stop trials for the Pfizer/BioNTech shot and all other mRNA trials until further studies had been done. They were particularly concerned about possible effects on fertility with 'vaccine'-produced antibodies attacking the protein Syncytin-1 which is responsible for developing the placenta. The result would be infertility 'of indefinite duration' in women who have the 'vaccine' with the placenta failing to form. Section 10.4.2 of the Pfizer/BioNTech trial protocol says that pregnant women or those who might become so should not have mRNA shots. Section 10.4 warns men taking mRNA shots to 'be abstinent from heterosexual intercourse' and not to donate sperm. The UK government said that it *did not know* if the mRNA procedure had an effect on fertility. *Did not know?* These people have to go to jail. UK government advice did not recommend at the start that pregnant women had the shot and said they should avoid pregnancy for at least two months after 'vaccination'. The 'advice' was later updated to pregnant women should only have the 'vaccine' if the benefits outweighed the risks to mother and foetus. What the hell is that supposed to mean? Then 'spontaneous abortions' began to appear and rapidly increase on the adverse reaction reporting schemes which include only a fraction of adverse reactions. Thousands and ever-growing numbers of 'vaccinated' women are describing changes to their menstrual cycle with heavier blood flow, irregular periods and menstruating again after going through the menopause – all links to reproduction effects. Women are passing blood clots and the lining of their uterus while men report erectile dysfunction and blood effects. Most

significantly of all *unvaccinated* women began to report similar menstrual changes after interaction with '*vaccinated*' people and men and children were also affected with bleeding noses, blood clots and other conditions. 'Shedding' is when vaccinated people can emit the content of a vaccine to affect the unvaccinated, but this is different. 'Vaccinated' people were not shedding a 'live virus' allegedly in 'vaccines' as before because the fake 'Covid vaccines' involve synthetic material and other toxicity. Doctors exposing what is happening prefer the term 'transmission' to shedding. Somehow those that have had the shots are transmitting effects to those that haven't. Dr Carrie Madej said the nano-content of the 'vaccines' can 'act like an antenna' to others around them which fits perfectly with my own conclusions. This 'vaccine' transmission phenomenon was becoming known as the book went into production and I deal with this further in the Postscript.

Vaccine effects on sterility are well known. The World Health Organization was accused in 2014 of sterilising millions of women in Kenya with the evidence confirmed by the content of the vaccines involved. The same WHO behind the 'Covid' hoax admitted its involvement for more than ten years with the vaccine programme. Other countries made similar claims. Charges were lodged by Tanzania, Nicaragua, Mexico, and the Philippines. The Gardasil vaccine claimed to protect against a genital 'virus' known as HPV has also been linked to infertility. Big Pharma and the WHO (same thing) are criminal and satanic entities. Then there's the Bill Gates Foundation which is connected through funding and shared interests with 20 pharmaceutical giants and laboratories. He stands accused of directing the policy of United Nations Children's Fund (UNICEF), vaccine alliance GAVI, and other groupings, to advance the vaccine agenda and silence opposition at great cost to women and children. At the same time Gates wants to reduce the global population. Coincidence?

**Great Reset = Smart Grid = new human**



The Cult agenda I have been exposing for 30 years is now being openly promoted by Cult assets like Gates and Klaus Schwab of the World Economic Forum under code-terms like the 'Great Reset', 'Build Back Better' and 'a rare but narrow window of opportunity to reflect, reimagine, and reset our world'. What provided this 'rare but narrow window of opportunity'? The 'Covid' hoax did. Who created that? *They* did. My books from not that long ago warned about the planned 'Internet of Things' (IoT) and its implications for human freedom. This was the plan to connect all technology to the Internet and artificial intelligence and today we are way down that road with an estimated 36 billion devices connected to the World Wide Web and that figure is projected to be 76 billion by 2025. I further warned that the Cult planned to go beyond that to the Internet of *Everything* when the human brain was connected via AI to the Internet and Kurzweil's 'cloud'. Now we have Cult operatives like Schwab calling for precisely that under the term 'Internet of Bodies', a fusion of the physical, digital and biological into one centrally-controlled Smart Grid system which the Cult refers to as the 'Fourth Industrial Revolution'. They talk about the 'biological', but they really mean the synthetic-biological which is required to fully integrate the human body and brain into the Smart Grid and artificial intelligence planned to replace the human mind. We have everything being synthetically manipulated including the natural world through GMO and smart dust, the food we eat and the human body itself with synthetic 'vaccines'. I said in *The Answer* that we would see the Cult push for synthetic meat to replace animals and in February, 2021, the so predictable psychopath Bill Gates called for the introduction of synthetic meat to save us all from 'climate change'. The climate hoax just keeps on giving like the 'Covid' hoax. The war on meat by vegan activists is a carbon (oops, sorry) copy of the manipulation of transgender activists. They have no idea (except their inner core) that they are being used to promote and impose the agenda of the Cult or that they are only the *vehicle* and not the *reason*. This is not to say those who choose not to eat meat shouldn't be respected and supported in that right, but there are ulterior motives

for those in power. A *Forbes* article in December, 2019, highlighted the plan so beloved of Schwab and the Cult under the heading: 'What Is The Internet of Bodies? And How Is It Changing Our World?' The article said the human body is the latest data platform (remember 'our vaccine is an operating system'). *Forbes* described the plan very accurately and the words could have come straight out of my books from long before:

The Internet of Bodies (IoB) is an extension of the IoT and basically connects the human body to a network through devices that are ingested, implanted, or connected to the body in some way. Once connected, data can be exchanged, and the body and device can be remotely monitored and controlled.

They were really describing a human hive mind with human perception centrally-dictated via an AI connection as well as allowing people to be 'remotely monitored and controlled'. Everything from a fridge to a human mind could be directed from a central point by these insane psychopaths and 'Covid vaccines' are crucial to this. *Forbes* explained the process I mentioned earlier of holdable and wearable technology followed by implantable. The article said there were three generations of the Internet of Bodies that include:

- Body external: These are wearable devices such as Apple Watches or Fitbits that can monitor our health.
- Body internal: These include pacemakers, cochlear implants, and digital pills that go inside our bodies to monitor or control various aspects of health.
- Body embedded: The third generation of the Internet of Bodies is embedded technology where technology and the human body are melded together and have a real-time connection to a remote machine.

*Forbes* noted the development of the Brain Computer Interface (BCI) which merges the brain with an external device for monitoring and controlling in real-time. 'The ultimate goal is to help restore function to individuals with disabilities by using brain signals rather than conventional neuromuscular pathways.' Oh, do fuck off. The goal of brain interface technology is controlling human thought and emotion from the central point in a hive mind serving its masters wishes. Many people are now agreeing to be chipped to open doors without a key. You can recognise them because they'll be wearing a mask, social distancing and lining up for the 'vaccine'. The Cult plans a Great Reset money system after they have completed the demolition of the global economy in which 'money' will be exchanged through communication with body operating systems. Rand Corporation, a Cult-owned think tank, said of the Internet of Bodies or IoB:

Internet of Bodies technologies fall under the broader IoT umbrella. But as the name suggests, IoB devices introduce an even more intimate interplay between humans and gadgets. IoB devices monitor the human body, collect health metrics and other personal information, and transmit those data over the Internet. Many devices, such as fitness trackers, are already in use ... IoB devices ... and those in development can track, record, and store users' whereabouts, bodily functions, and what they see, hear, and even think.

Schwab's World Economic Forum, a long-winded way of saying 'fascism' or 'the Cult', has gone full-on with the Internet of Bodies in the 'Covid' era. 'We're entering the era of the Internet of Bodies', it declared, 'collecting our physical data via a range of devices that can be implanted, swallowed or worn'. The result would be a huge amount of health-related data that could improve human wellbeing around the world, and prove crucial in fighting the 'Covid-19 pandemic'. Does anyone think these clowns care about 'human wellbeing' after the death and devastation their pandemic hoax has purposely caused? Schwab and co say we should move forward with the Internet of Bodies because 'Keeping track of symptoms could help us stop the spread of infection, and quickly detect new cases'. How wonderful, but keeping track' is all they are really bothered

about. Researchers were investigating if data gathered from smartwatches and similar devices could be used as viral infection alerts by tracking the user's heart rate and breathing. Schwab said in his 2018 book *Shaping the Future of the Fourth Industrial Revolution*:

The lines between technologies and beings are becoming blurred and not just by the ability to create lifelike robots or synthetics. Instead it is about the ability of new technologies to literally become part of us. Technologies already influence how we understand ourselves, how we think about each other, and how we determine our realities. As the technologies ... give us deeper access to parts of ourselves, we may begin to integrate digital technologies into our bodies.

You can see what the game is. Twenty-four hour control and people – if you could still call them that – would never know when something would go ping and take them out of circulation. It's the most obvious rush to a global fascist dictatorship and the complete submission of humanity and yet still so many are locked away in their Cult-induced perceptual coma and can't see it.

### **Smart Grid control centres**

The human body is being transformed by the 'vaccines' and in other ways into a synthetic cyborg that can be attached to the global Smart Grid which would be controlled from a central point and other sub-locations of Grid manipulation. Where are these planned to be? Well, China for a start which is one of the Cult's biggest centres of operation. The technological control system and technocratic rule was incubated here to be unleashed across the world after the 'Covid' hoax came out of China in 2020. Another Smart Grid location that will surprise people new to this is Israel. I have exposed in *The Trigger* how Sabbatian technocrats, intelligence and military operatives were behind the horrors of 9/11 and not 19 Arab hijackers' who somehow manifested the ability to pilot big passenger airliners when instructors at puddle-jumping flying schools described some of them as a joke. The 9/11 attacks were made possible through control of civilian and military air computer systems and those of the White House, Pentagon and connected agencies. See *The Trigger* – it

will blow your mind. The controlling and coordinating force were the Sabbatian networks in Israel and the United States which by then had infiltrated the entire US government, military and intelligence system. The real name of the American Deep State is 'Sabbatian State'. Israel is a tiny country of only nine million people, but it is one of the global centres of cyber operations and fast catching Silicon Valley in importance to the Cult. Israel is known as the 'start-up nation' for all the cyber companies spawned there with the Sabbatian specialisation of 'cyber security' that I mentioned earlier which gives those companies access to computer systems of their clients in real time through 'backdoors' written into the coding when security software is downloaded. The Sabbatian centre of cyber operations outside Silicon Valley is the Israeli military Cyber Intelligence Unit, the biggest infrastructure project in Israel's history, headquartered in the desert-city of Beersheba and involving some 20,000 'cyber soldiers'. Here are located a literal army of Internet trolls scanning social media, forums and comment lists for anyone challenging the Cult agenda. The UK military has something similar with its 77th Brigade and associated operations. The Beersheba complex includes research and development centres for other Cult operations such as Intel, Microsoft, IBM, Google, Apple, Hewlett-Packard, Cisco Systems, Facebook and Motorola. [Techcrunch.com](http://Techcrunch.com) ran an article about the Beersheba global Internet technology centre headlined 'Israel's desert city of Beersheba is turning into a cybertech oasis':

The military's massive relocation of its prestigious technology units, the presence of multinational and local companies, a close proximity to Ben Gurion University and generous government subsidies are turning Beersheba into a major global cybertech hub. Beersheba has all of the ingredients of a vibrant security technology ecosystem, including Ben Gurion University with its graduate program in cybersecurity and Cyber Security Research Center, and the presence of companies such as EMC, Deutsche Telekom, PayPal, Oracle, IBM, and Lockheed Martin. It's also the future home of the INCB (Israeli National Cyber Bureau); offers a special income tax incentive for cyber security companies, and was the site for the relocation of the army's intelligence corps units.

Sabbatians have taken over the cyber world through the following process: They scan the schools for likely cyber talent and develop them at Ben Gurion University and their period of conscription in the Israeli Defense Forces when they are stationed at the Beersheba complex. When the cyber talented officially leave the army they are funded to start cyber companies with technology developed by themselves or given to them by the state. Much of this is stolen through backdoors of computer systems around the world with America top of the list. Others are sent off to Silicon Valley to start companies or join the major ones and so we have many major positions filled by apparently 'Jewish' but really Sabbatian operatives. Google, YouTube and Facebook are all run by 'Jewish' CEOs while Twitter is all but run by ultra-Zionist hedge-fund shark Paul Singer. At the centre of the Sabbatian global cyber web is the Israeli army's Unit 8200 which specialises in hacking into computer systems of other countries, inserting viruses, gathering information, instigating malfunction, and even taking control of them from a distance. A long list of Sabbatians involved with 9/11, Silicon Valley and Israeli cyber security companies are operatives of Unit 8200. This is not about Israel. It's about the Cult. Israel is planned to be a Smart Grid hub as with China and what is happening at Beersheba is not for the benefit of Jewish people who are treated disgustingly by the Sabbatian elite that control the country. A glance at the Nuremberg Codes will tell you that.

The story is much bigger than 'Covid', important as that is to where we are being taken. Now, though, it's time to really strap in. There's more ... much more ...

## CHAPTER ELEVEN

### Who controls the Cult?

*Awake, arise or be forever fall'n*  
John Milton, *Paradise Lost*

I have exposed this far the level of the Cult conspiracy that operates in the world of the seen and within the global secret society and satanic network which operates in the shadows one step back from the seen. The story, however, goes much deeper than that.

The 'Covid' hoax is major part of the Cult agenda, but only part, and to grasp the biggest picture we have to expand our attention beyond the realm of human sight and into the infinity of possibility that we cannot see. It is from here, ultimately, that humanity is being manipulated into a state of total control by the force which dictates the actions of the Cult. How much of reality can we see? Next to damn all is the answer. We may appear to see all there is to see in the 'space' our eyes survey and observe, but little could be further from the truth. The human 'world' is only a tiny band of frequency that the body's visual and perceptual systems can decode into *perception* of a 'world'. According to mainstream science the electromagnetic spectrum is 0.005 percent of what exists in the Universe (Fig 10). The maximum estimate I have seen is 0.5 percent and either way it's miniscule. I say it is far, far, smaller even than 0.005 percent when you compare reality we see with the totality of reality that we don't. Now get this if you are new to such information: Visible light, the only band of frequency that we can see, is a *fraction* of the 0.005

percent (Fig 11 overleaf). Take this further and realise that our universe is one of infinite universes and that universes are only a fragment of overall reality – *infinite* reality. Then compare that with the almost infinitesimal frequency band of visible light or human sight. You see that humans are as near blind as it is possible to be without actually being so. Artist and filmmaker, Sergio Toporek, said:

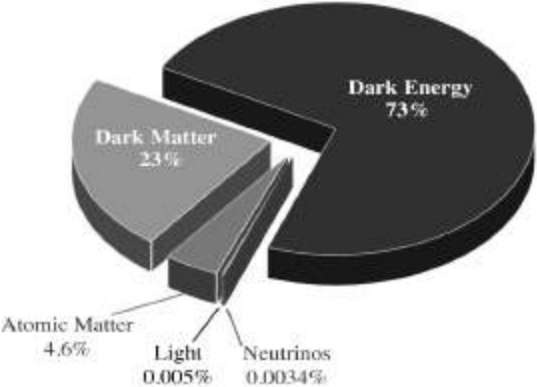


Figure 10: Humans can perceive such a tiny band of visual reality it's laughable.

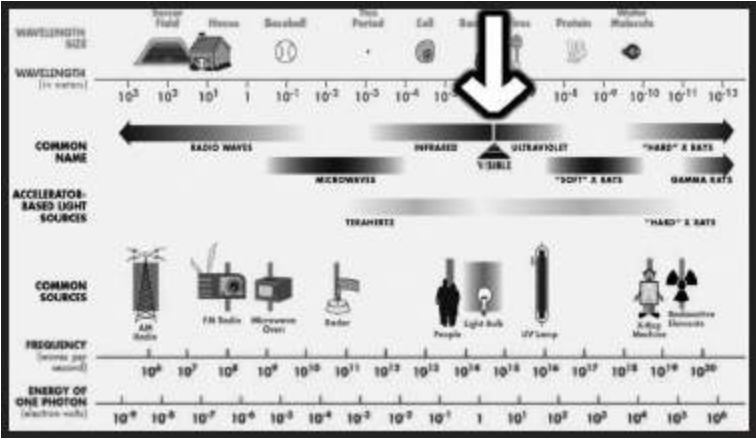


Figure 11: We can see a smear of the 0.005 percent electromagnetic spectrum, but we still know it all. Yep, makes sense.

Consider that you can see less than 1% of the electromagnetic spectrum and hear less than 1% of the acoustic spectrum. 90% of the cells in your body carry their own microbial DNA and are not 'you'. The atoms in your body are 99.9999999999999999% empty space and none of them are the ones you were born with ... Human beings have 46 chromosomes, two less than a potato.



The existence of the rainbow depends on the conical photoreceptors in your eyes; to animals without cones, the rainbow does not exist. So you don't just look at a rainbow, you create it. This is pretty amazing, especially considering that all the beautiful colours you see represent less than 1% of the electromagnetic spectrum.

Suddenly the 'world' of humans looks a very different place. Take into account, too, that Planet Earth when compared with the projected size of this single universe is the equivalent of a billionth of a pinhead. Imagine the ratio that would be when compared to infinite reality. To think that Christianity once insisted that Earth and humanity were the centre of everything. This background is vital if we are going to appreciate the nature of 'human' and how we can be manipulated by an unseen force. To human visual reality virtually *everything* is unseen and yet the prevailing perception within the institutions and so much of the public is that if we can't see it, touch it, hear it, taste it and smell it then it cannot exist. Such perception is indoctrinated and encouraged by the Cult and its agents because it isolates believers in the strictly limited, village-idiot, realm of the five senses where perceptions can be firewalled and information controlled. Most of those perpetuating the 'this-world-is-all-there-is' insanity are themselves indoctrinated into believing the same delusion. While major players and influencers know that official reality is laughable most of those in science, academia and medicine really believe the nonsense they peddle and teach succeeding generations. Those who challenge the orthodoxy are dismissed as nutters and freaks to protect the manufactured illusion from exposure. Observe the dynamic of the 'Covid' hoax and you will see how that takes the same form. The inner-circle psychopaths knows it's a gigantic scam, but almost the entirety of those imposing their fascist rules believe that 'Covid' is all that they're told it is.

## **Stolen identity**

Ask people who they are and they will give you their name, place of birth, location, job, family background and life story. Yet that is not who they are – it is what they are *experiencing*. The difference is *absolutely crucial*. The true 'I', the eternal, infinite 'I', is consciousness,

a state of being aware. Forget 'form'. That is a vehicle for a brief experience. Consciousness does not come *from* the brain, but *through* the brain and even that is more symbolic than literal. We are awareness, pure awareness, and this is what withdraws from the body at what we call 'death' to continue our eternal beingness, *isness*, in other realms of reality within the limitlessness of infinity or the Biblical 'many mansions in my father's house'. Labels of a human life, man, woman, transgender, black, white, brown, nationality, circumstances and income are not who we are. They are what we are – awareness – is *experiencing* in a brief connection with a band of frequency we call 'human'. The labels are not the self; they are, to use the title of one of my books, a *Phantom Self*. I am not David Icke born in Leicester, England, on April 29th, 1952. I am the consciousness *having that experience*. The Cult and its non-human masters seek to convince us through the institutions of 'education', science, medicine, media and government that what we are *experiencing* is who we *are*. It's so easy to control and direct perception locked away in the bewildered illusions of the five senses with no expanded radar. Try, by contrast, doing the same with a humanity aware of its true self and its true power to consciously create its reality and experience. How is it possible to do this? We do it all day every day. If you perceive yourself as 'little me' with no power to impact upon your life and the world then your life experience will reflect that. You will hand the power you don't think you have to authority in all its forms which will use it to control your experience. This, in turn, will appear to confirm your perception of 'little me' in a self-fulfilling feedback loop. But that is what 'little me' really is – a *perception*. We are all 'big-me', infinite me, and the Cult has to make us forget that if its will is to prevail. We are therefore manipulated and pressured into self-identifying with human labels and not the consciousness/awareness *experiencing* those human labels.

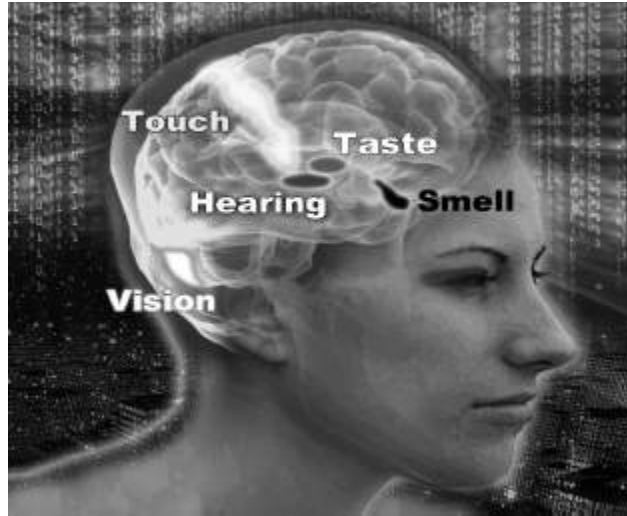
The phenomenon of identity politics is a Cult-instigated manipulation technique to sub-divide previous labels into even smaller ones. A United States university employs this list of letters to

describe student identity: LGBTTQQFAGPBDSM or lesbian, gay, bisexual, transgender, transsexual, queer, questioning, flexual, asexual, gender-fuck, polyamorous, bondage/discipline, dominance/submission and sadism/masochism. I'm sure other lists are even longer by now as people feel the need to self-identity the 'I' with the minutiae of race and sexual preference. Wokers programmed by the Cult for generations believe this is about 'inclusivity' when it's really the Cult locking them away into smaller and smaller versions of Phantom Self while firewalling them from the influence of their true self, the infinite, eternal 'I'. You may notice that my philosophy which contends that we are all unique points of attention/awareness within the same infinite whole or Oneness is the ultimate non-racism. The very sense of Oneness makes the judgement of people by their body-type, colour or sexuality utterly ridiculous and confirms that racism has no understanding of reality (including anti-white racism). Yet despite my perception of life Cult agents and fast-asleep Wokers label me racist to discredit my information while they are themselves phenomenally racist and sexist. All they see is race and sexuality and they judge people as good or bad, demons or untouchables, by their race and sexuality. All they see is *Phantom Self* and perceive themselves in terms of Phantom Self. They are pawns and puppets of the Cult agenda to focus attention and self-identity in the five senses and play those identities against each other to divide and rule. Columbia University has introduced segregated graduations in another version of social distancing designed to drive people apart and teach them that different racial and cultural groups have nothing in common with each other. The last thing the Cult wants is unity. Again the pump-primers of this will be Cult operatives in the knowledge of what they are doing, but the rest are just the Phantom Self blind leading the Phantom Self blind. We *do* have something in common – we are all *the same consciousness* having different temporary experiences.

## **What is this 'human'?**

Yes, what *is* 'human'? That is what we are supposed to be, right? I mean 'human'? True, but 'human' is the experience not the 'I'. Break it down to basics and 'human' is the way that information is processed. If we are to experience and interact with this band of frequency we call the 'world' we must have a vehicle that operates within that band of frequency. Our consciousness in its prime form cannot do that; it is way beyond the frequency of the human realm. My consciousness or awareness could not tap these keys and pick up the cup in front of me in the same way that radio station A cannot interact with radio station B when they are on different frequencies. The human body is the means through which we have that interaction. I have long described the body as a biological computer which processes information in a way that allows consciousness to experience this reality. The body is a receiver, transmitter and processor of information in a particular way that we call human. We visually perceive only the world of the five senses in a wakened state – that is the limit of the body's visual decoding system. In truth it's not even visual in the way we experience 'visual reality' as I will come to in a moment. We are 'human' because the body processes the information sources of human into a reality and behaviour system that we *perceive* as human. Why does an elephant act like an elephant and not like a human or a duck? The elephant's biological computer is a different information field and processes information according to that program into a visual and behaviour type we call an elephant. The same applies to everything in our reality. These body information fields are perpetuated through procreation (like making a copy of a software program). The Cult wants to break that cycle and intervene technologically to transform the human information field into one that will change what we call humanity. If it can change the human information field it will change the way that field processes information and change humanity both 'physically' and psychologically. Hence the *messenger* (information) RNA 'vaccines' and so much more that is targeting human genetics by changing the body's information – *messaging* – construct through food, drink, radiation, toxicity and other means.

Reality that we experience is nothing like reality as it really is in the same way that the reality people experience in virtual reality games is not the reality they are really living in. The game is only a decoded source of information that appears to be a reality. Our world is also an information construct – a *simulation* (more later). In its base form our reality is a wavefield of information much the same in theme as Wi-Fi. The five senses decode wavefield information into electrical information which they communicate to the brain to decode into holographic (illusory ‘physical’) information. Different parts of the brain specialise in decoding different senses and the information is fused into a reality that appears to be outside of us but is really inside the brain and the genetic structure in general (Fig 12 overleaf). DNA is a receiver-transmitter of information and a vital part of this decoding process and the body’s connection to other realities. Change DNA and you change the way we decode and connect with reality – see ‘Covid vaccines’. Think of computers decoding Wi-Fi. You have information encoded in a radiation field and the computer decodes that information into a very different form on the screen. You can’t see the Wi-Fi until its information is made manifest on the screen and the information on the screen is inside the computer and not outside. I have just described how we decode the ‘human world’. All five senses decode the waveform ‘Wi-Fi’ field into electrical signals and the brain (computer) constructs reality inside the brain and not outside – ‘You don’t just look at a rainbow, you create it’. Sound is a simple example. We don’t hear sound until the brain decodes it. Waveform sound waves are picked up by the hearing sense and communicated to the brain in an electrical form to be decoded into the sounds that we hear. Everything we hear is inside the brain along with everything we see, feel, smell and taste. Words and language are waveform fields generated by our vocal chords which pass through this process until they are decoded by the brain into words that we hear. Different languages are different frequency fields or sound waves generated by vocal chords. Late British philosopher Alan Watts said:



**Figure 12:** The brain receives information from the five senses and constructs from that our perceived reality.

[Without the brain] the world is devoid of light, heat, weight, solidity, motion, space, time or any other imaginable feature. All these phenomena are interactions, or transactions, of vibrations with a certain arrangement of neurons.

That's exactly what they are and scientist Robert Lanza describes in his book, *Biocentrism*, how we decode electromagnetic waves and energy into visual and 'physical' experience. He uses the example of a flame emitting photons, electromagnetic energy, each pulsing electrically and magnetically:

... these ... invisible electromagnetic waves strike a human retina, and if (and only if) the waves happen to measure between 400 and 700 nano meters in length from crest to crest, then their energy is just right to deliver a stimulus to the 8 million cone-shaped cells in the retina.

Each in turn send an electrical pulse to a neighbour neuron, and on up the line this goes, at 250 mph, until it reaches the ... occipital lobe of the brain, in the back of the head. There, a cascading complex of neurons fire from the incoming stimuli, and we subjectively perceive this experience as a yellow brightness occurring in a place we have been conditioned to call the 'external world'.

**You hear what you decode**

If a tree falls or a building collapses they make no noise unless someone is there to decode the energetic waves generated by the disturbance into what we call sound. Does a falling tree make a noise? Only if you hear it – *decode* it. Everything in our reality is a frequency field of information operating within the overall ‘Wi-Fi’ field that I call The Field. A vibrational disturbance is generated in The Field by the fields of the falling tree or building. These disturbance waves are what we decode into the sound of them falling. If no one is there to do that then neither will make any noise. Reality is created by the observer – *decoder* – and the *perceptions* of the observer affect the decoding process. For this reason different people – different *perceptions* – will perceive the same reality or situation in a different way. What one may perceive as a nightmare another will see as an opportunity. The question of why the Cult is so focused on controlling human perception now answers itself. All experienced reality is the act of decoding and we don’t experience Wi-Fi until it is decoded on the computer screen. The sight and sound of an Internet video is encoded in the Wi-Fi all around us, but we don’t see or hear it until the computer decodes that information. Taste, smell and touch are all phenomena of the brain as a result of the same process. We don’t taste, smell or feel anything except in the brain and there are pain relief techniques that seek to block the signal from the site of discomfort to the brain because if the brain doesn’t decode that signal we don’t feel pain. Pain is in the brain and only appears to be at the point of impact thanks to the feedback loop between them. We don’t see anything until electrical information from the sight senses is decoded in an area at the back of the brain. If that area is damaged we can go blind when our eyes are perfectly okay. So why do we go blind if we damage an eye? We damage the information processing between the waveform visual information and the visual decoding area of the brain. If information doesn’t reach the brain in a form it can decode then we can’t see the visual reality that it represents. What’s more the brain is decoding only a fraction of the information it receives and the rest is absorbed by the

sub-conscious mind. This explanation is from the science magazine, *Wonderpedia*:

Every second, 11 million sensations crackle along these [brain] pathways ... The brain is confronted with an alarming array of images, sounds and smells which it rigorously filters down until it is left with a manageable list of around 40. Thus 40 sensations per second make up what we perceive as reality.

The 'world' is not what people are told to believe that is it and the inner circles of the Cult *know that*.

### **Illusory 'physical' reality**

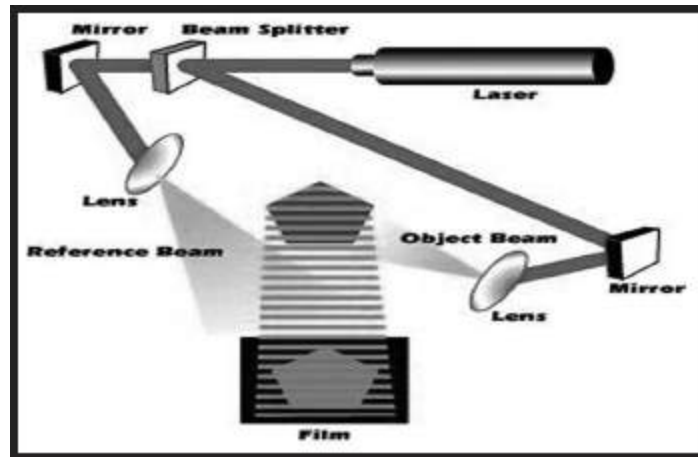
We can only see a smear of 0.005 percent of the Universe which is only one of a vast array of universes – 'mansions' – within infinite reality. Even then the brain decodes only 40 pieces of information ('sensations') from a potential *11 million* that we receive every second. Two points strike you from this immediately: The sheer breathtaking stupidity of believing we know anything so rigidly that there's nothing more to know; and the potential for these processes to be manipulated by a malevolent force to control the reality of the population. One thing I can say for sure with no risk of contradiction is that when you can perceive an almost indescribable fraction of infinite reality there is always more to know as in tidal waves of it. Ancient Greek philosopher Socrates was so right when he said that wisdom is to know how little we know. How obviously true that is when you think that we are experiencing a physical world of solidity that is neither physical nor solid and a world of apartness when everything is connected. Cult-controlled 'science' dismisses the so-called 'paranormal' and all phenomena related to that when the 'para'-normal is perfectly normal and explains the alleged 'great mysteries' which dumbfound scientific minds. There is a reason for this. A 'scientific mind' in terms of the mainstream is a material mind, a five-sense mind imprisoned in see it, touch it, hear it, smell it and taste it. Phenomena and happenings that can't be explained that way leave the 'scientific mind' bewildered and the rule is that if they



can't account for why something is happening then it can't, by definition, be happening. I beg to differ. Telepathy is thought waves passing through The Field (think wave disturbance again) to be decoded by someone able to connect with that wavelength (information). For example: You can pick up the thought waves of a friend at any distance and at the very least that will bring them to mind. A few minutes later the friend calls you. 'My god', you say, 'that's incredible – I was just thinking of you.' Ah, but *they* were thinking of *you* before they made the call and that's what you decoded. Native peoples not entrapped in five-sense reality do this so well it became known as the 'bush telegraph'. Those known as psychics and mediums (genuine ones) are doing the same only across dimensions of reality. 'Mind over matter' comes from the fact that matter and mind are the *same*. The state of one influences the state of the other. Indeed one *and* the other are illusions. They are aspects of the same field. Paranormal phenomena are all explainable so why are they still considered 'mysteries' or not happening? Once you go down this road of understanding you begin to expand awareness beyond the five senses and that's the nightmare for the Cult.



**Figure 13:** Holograms are not solid, but the best ones appear to be.



**Figure 14:** How holograms are created by capturing a waveform version of the subject image.

### **Holographic 'solidity'**

Our reality is not solid, it is holographic. We are now well aware of holograms which are widely used today. Two-dimensional information is decoded into a three-dimensional reality that is not solid although can very much appear to be (Fig 13). Holograms are created with a laser divided into two parts. One goes directly onto a holographic photographic print ('reference beam') and the other takes a waveform image of the subject ('working beam') before being directed onto the print where it 'collides' with the other half of the laser (Fig 14). This creates a *waveform* interference pattern which contains the wavefield information of whatever is being photographed (Fig 15 overleaf). The process can be likened to dropping pebbles in a pond. Waves generated by each one spread out across the water to collide with the others and create a wave representation of where the stones fell and at what speed, weight and distance. A waveform interference pattern of a hologram is akin to the waveform information in The Field which the five senses decode into electrical signals to be decoded by the brain into a holographic illusory 'physical' reality. In the same way when a laser (think human attention) is directed at the waveform interference pattern a three-dimensional version of the subject is projected into apparently 'solid' reality (Fig 16). An amazing trait of holograms reveals more 'paranormal mysteries'. Information of the *whole*

hologram is encoded in waveform in every part of the interference pattern by the way they are created. This means that every *part* of a hologram is a smaller version of the whole. Cut the interference wave-pattern into four and you won't get four parts of the image. You get quarter-sized versions of the *whole* image. The body is a hologram and the same applies. Here we have the basis of acupuncture, reflexology and other forms of healing which identify representations of the whole body in all of the parts, hands, feet, ears, everywhere. Skilled palm readers can do what they do because the information of whole body is encoded in the hand. The concept of as above, so below, comes from this.



**Figure 15:** A waveform interference pattern that holds the information that transforms into a hologram.



**Figure 16:** Holographic people including 'Elvis' holographically inserted to sing a duet with Celine Dion.

The question will be asked of why, if solidity is illusory, we can't just walk through walls and each other. The resistance is not solid against solid; it is electromagnetic field against electromagnetic field and we decode this into the *experience* of solid against solid. We should also not underestimate the power of belief to dictate reality. What you believe is impossible *will be*. Your belief impacts on your decoding processes and they won't decode what you think is impossible. What we believe we perceive and what we perceive we experience. 'Can't dos' and 'impossibles' are like a firewall in a computer system that won't put on the screen what the firewall blocks. How vital that is to understanding how human experience has been hijacked. I explain in *The Answer, Everything You Need To Know But Have Never Been Told* and other books a long list of 'mysteries' and 'paranormal' phenomena that are not mysterious and perfectly normal once you realise what reality is and how it works. 'Ghosts' can be seen to pass through 'solid' walls because the walls are not solid and the ghost is a discarnate entity operating on a frequency so different to that of the wall that it's like two radio stations sharing the same space while never interfering with each other. I have seen ghosts do this myself. The apartness of people and objects is also an illusion. Everything is connected by the Field like all sea life is connected by the sea. It's just that within the limits of our visual reality we only 'see' holographic information and not the field of information that connects everything and from which the holographic world is made manifest. If you can only see holographic 'objects' and not the field that connects them they will appear to you as unconnected to each other in the same way that we see the computer while not seeing the Wi-Fi.

### **What you don't know *can* hurt you**

Okay, we return to those 'two worlds' of human society and the Cult with its global network of interconnecting secret societies and satanic groups which manipulate through governments, corporations, media, religions, etc. The fundamental difference between them is *knowledge*. The idea has been to keep humanity

ignorant of the plan for its total enslavement underpinned by a crucial ignorance of reality – who we are and where we are – and how we interact with it. ‘Human’ should be the interaction between our expanded eternal consciousness and the five-sense body experience. We are meant to be *in* this world in terms of the five senses but not *of* this world in relation to our greater consciousness and perspective. In that state we experience the small picture of the five senses within the wider context of the big picture of awareness beyond the five senses. Put another way the five senses see the dots and expanded awareness connects them into pictures and patterns that give context to the apparently random and unconnected. Without the context of expanded awareness the five senses see only apartness and randomness with apparently no meaning. The Cult and its other-dimensional controllers seek to intervene in the frequency realm where five-sense reality is supposed to connect with expanded reality and to keep the two apart (more on this in the final chapter). When that happens five-sense mental and emotional processes are no longer influenced by expanded awareness, or the True ‘I’, and instead are driven by the isolated perceptions of the body’s decoding systems. They are in the world *and* of it. Here we have the human plight and why humanity with its potential for infinite awareness can be so easily manipulatable and descend into such extremes of stupidity.

Once the Cult isolates five-sense mind from expanded awareness it can then program the mind with perceptions and beliefs by controlling information that the mind receives through the ‘education’ system of the formative years and the media perceptual bombardment and censorship of an entire lifetime. Limit perception and a sense of the possible through limiting knowledge by limiting and skewing information while censoring and discrediting that which could set people free. As the title of another of my books says ... *And The Truth Shall Set You Free*. For this reason the last thing the Cult wants in circulation is the truth about anything – especially the reality of the eternal ‘I’ – and that’s why it is desperate to control information. The Cult knows that information becomes perception

which becomes behaviour which, collectively, becomes human society. Cult-controlled and funded mainstream 'science' denies the existence of an eternal 'I' and seeks to dismiss and trash all evidence to the contrary. Cult-controlled mainstream religion has a version of 'God' that is little more than a system of control and dictatorship that employs threats of damnation in an afterlife to control perceptions and behaviour in the here and now through fear and guilt. Neither is true and it's the 'neither' that the Cult wishes to suppress. This 'neither' is that everything is an expression, a point of attention, within an infinite state of consciousness which is the real meaning of the term 'God'.

Perceptual obsession with the 'physical body' and five-senses means that 'God' becomes personified as a bearded bloke sitting among the clouds or a raging bully who loves us if we do what 'he' wants and condemns us to the fires of hell if we don't. These are no more than a 'spiritual' fairy tales to control and dictate events and behaviour through fear of this 'God' which has bizarrely made 'God-fearing' in religious circles a state to be desired. I would suggest that fearing *anything* is not to be encouraged and celebrated, but rather deleted. You can see why 'God fearing' is so beneficial to the Cult and its religions when *they* decide what 'God' wants and what 'God' demands (the Cult demands) that everyone do. As the great American comedian Bill Hicks said satirising a Christian zealot: 'I think what God meant to say.' How much of this infinite awareness ('God') that we access is decided by how far we choose to expand our perceptions, self-identity and sense of the possible. The scale of self-identity reflects itself in the scale of awareness that we can connect with and are influenced by – how much knowing and insight we have instead of programmed perception. You cannot expand your awareness into the infinity of possibility when you believe that you are little me Peter the postman or Mary in marketing and nothing more. I'll deal with this in the concluding chapter because it's crucial to how we turnaround current events.

## **Where the Cult came from**

When I realised in the early 1990s there was a Cult network behind global events I asked the obvious question: When did it start? I took it back to ancient Rome and Egypt and on to Babylon and Sumer in Mesopotamia, the 'Land Between Two Rivers', in what we now call Iraq. The two rivers are the Tigris and Euphrates and this region is of immense historical and other importance to the Cult, as is the land called Israel only 550 miles away by air. There is much more going on with deep esoteric meaning across this whole region. It's not only about 'wars for oil'. Priceless artefacts from Mesopotamia were stolen or destroyed after the American and British invasion of Iraq in 2003 justified by the lies of Boy Bush and Tony Blair (their Cult masters) about non-existent 'weapons of mass destruction'.

Mesopotamia was the location of Sumer (about 5,400BC to 1,750BC), and Babylon (about 2,350BC to 539BC). Sabbatians may have become immensely influential in the Cult in modern times but they are part of a network that goes back into the mists of history. Sumer is said by historians to be the 'cradle of civilisation'. I disagree. I say it was the re-start of what we call human civilisation after cataclysmic events symbolised in part as the 'Great Flood' destroyed the world that existed before. These fantastic upheavals that I have been describing in detail in the books since the early 1990s appear in accounts and legends of ancient cultures across the world and they are supported by geological and biological evidence. Stone tablets found in Iraq detailing the Sumer period say the cataclysms were caused by non-human 'gods' they call the Anunnaki. These are described in terms of extraterrestrial visitations in which knowledge supplied by the Anunnaki is said to have been the source of at least one of the world's oldest writing systems and developments in astronomy, mathematics and architecture that were way ahead of their time. I have covered this subject at length in *The Biggest Secret* and *Children of the Matrix* and the same basic 'Anunnaki' story can be found in Zulu accounts in South Africa where the late and very great Zulu high shaman Credo Mutwa told me that the Sumerian Anunnaki were known by Zulus as the Chitauri or 'children of the serpent'. See my six-hour video interview with Credo on this subject entitled *The*

*Reptilian Agenda* recorded at his then home near Johannesburg in 1999 which you can watch on the Ickonic media platform.

The Cult emerged out of Sumer, Babylon and Egypt (and elsewhere) and established the Roman Empire before expanding with the Romans into northern Europe from where many empires were savagely imposed in the form of Cult-controlled societies all over the world. Mass death and destruction was their calling card. The Cult established its centre of operations in Europe and European Empires were Cult empires which allowed it to expand into a global force. Spanish and Portuguese colonialists headed for Central and South America while the British and French targeted North America. Africa was colonised by Britain, France, Belgium, the Netherlands, Portugal, Spain, Italy, and Germany. Some like Britain and France moved in on the Middle East. The British Empire was by far the biggest for a simple reason. By now Britain was the headquarters of the Cult from which it expanded to form Canada, the United States, Australia and New Zealand. The Sun never set on the British Empire such was the scale of its occupation. London remains a global centre for the Cult along with Rome and the Vatican although others have emerged in Israel and China. It is no accident that the 'virus' is alleged to have come out of China while Italy was chosen as the means to terrify the Western population into compliance with 'Covid' fascism. Nor that Israel has led the world in 'Covid' fascism and mass 'vaccination'.

You would think that I would mention the United States here, but while it has been an important means of imposing the Cult's will it is less significant than would appear and is currently in the process of having what power it does have deleted. The Cult in Europe has mostly loaded the guns for the US to fire. America has been controlled from Europe from the start through Cult operatives in Britain and Europe. The American Revolution was an illusion to make it appear that America was governing itself while very different forces were pulling the strings in the form of Cult families such as the Rothschilds through the Rockefellers and other subordinates. The Rockefellers are extremely close to Bill Gates and



established both scalpel and drug 'medicine' and the World Health Organization. They play a major role in the development and circulation of vaccines through the Rockefeller Foundation on which Bill Gates said his Foundation is based. Why wouldn't this be the case when the Rockefellers and Gates are on the same team? Cult infiltration of human society goes way back into what we call history and has been constantly expanding and centralising power with the goal of establishing a global structure to dictate everything. Look how this has been advanced in great leaps with the 'Covid' hoax.

### **The non-human dimension**

I researched and observed the comings and goings of Cult operatives through the centuries and even thousands of years as they were born, worked to promote the agenda within the secret society and satanic networks, and then died for others to replace them. Clearly there had to be a coordinating force that spanned this entire period while operatives who would not have seen the end goal in their lifetimes came and went advancing the plan over millennia. I went in search of that coordinating force with the usual support from the extraordinary synchronicity of my life which has been an almost daily experience since 1990. I saw common themes in religious texts and ancient cultures about a non-human force manipulating human society from the hidden. Christianity calls this force Satan, the Devil and demons; Islam refers to the Jinn or Djinn; Zulus have their Chitauri (spelt in other ways in different parts of Africa); and the Gnostic people in Egypt in the period around and before 400AD referred to this phenomena as the 'Archons', a word meaning rulers in Greek. Central American cultures speak of the 'Predators' among other names and the same theme is everywhere. I will use 'Archons' as a collective name for all of them. When you see how their nature and behaviour is described all these different sources are clearly talking about the same force. Gnostics described the Archons in terms of 'luminous fire' while Islam relates the Jinn to 'smokeless fire'. Some refer to beings in form that could occasionally be seen, but the most common of common theme is that they operate from

unseen realms which means almost all existence to the visual processes of humans. I had concluded that this was indeed the foundation of human control and that the Cult was operating within the human frequency band on behalf of this hidden force when I came across the writings of Gnostics which supported my conclusions in the most extraordinary way.

A sealed earthen jar was found in 1945 near the town of Nag Hammadi about 75-80 miles north of Luxor on the banks of the River Nile in Egypt. Inside was a treasure trove of manuscripts and texts left by the Gnostic people some 1,600 years earlier. They included 13 leather-bound papyrus codices (manuscripts) and more than 50 texts written in Coptic Egyptian estimated to have been hidden in the jar in the period of 400AD although the source of the information goes back much further. Gnostics oversaw the Great or Royal Library of Alexandria, the fantastic depository of ancient texts detailing advanced knowledge and accounts of human history. The Library was dismantled and destroyed in stages over a long period with the death-blow delivered by the Cult-established Roman Church in the period around 415AD. The Church of Rome was the Church of Babylon relocated as I said earlier. Gnostics were not a race. They were a way of perceiving reality. Whenever they established themselves and their information circulated the terrorists of the Church of Rome would target them for destruction. This happened with the Great Library and with the Gnostic Cathars who were burned to death by the psychopaths after a long period of oppression at the siege of the Castle of Monségur in southern France in 1244. The Church has always been terrified of Gnostic information which demolishes the official Christian narrative although there is much in the Bible that supports the Gnostic view if you read it in another way. To anyone studying the texts of what became known as the Nag Hammadi Library it is clear that great swathes of Christian and Biblical belief has its origin with Gnostics sources going back to Sumer. Gnostic themes have been twisted to manipulate the perceived reality of Bible believers. Biblical texts have been in the open for centuries where they could be changed while Gnostic

documents found at Nag Hammadi were sealed away and untouched for 1,600 years. What you see is what they wrote.

### **Use your *pneuma* not your *nous***

Gnosticism and Gnostic come from 'gnosis' which means knowledge, or rather *secret* knowledge, in the sense of spiritual awareness – knowledge about reality and life itself. The desperation of the Cult's Church of Rome to destroy the Gnostics can be understood when the knowledge they were circulating was the last thing the Cult wanted the population to know. Sixteen hundred years later the same Cult is working hard to undermine and silence me for the same reason. The dynamic between knowledge and ignorance is a constant. 'Time' appears to move on, but essential themes remain the same. We are told to 'use your nous', a Gnostic word for head/brain/intelligence. They said, however, that spiritual awakening or 'salvation' could only be secured by expanding awareness *beyond* what they called *nous* and into *pneuma* or Infinite Self. Obviously as I read these texts the parallels with what I have been saying since 1990 were fascinating to me. There is a universal truth that spans human history and in that case why wouldn't we be talking the same language 16 centuries apart? When you free yourself from the perception program of the five senses and explore expanded realms of consciousness you are going to connect with the same information no matter what the perceived 'era' within a manufactured timeline of a single and tiny range of manipulated frequency. Humans working with 'smart' technology or knocking rocks together in caves is only a timeline appearing to operate within the human frequency band. Expanded awareness and the knowledge it holds have always been there whether the era be Stone Age or computer age. We can only access that knowledge by opening ourselves to its frequency which the five-sense prison cell is designed to stop us doing. Gates, Fauci, Whitty, Vallance, Zuckerberg, Brin, Page, Wojcicki, Bezos, and all the others behind the 'Covid' hoax clearly have a long wait before their range of frequency can make that connection given that an open heart is

crucial to that as we shall see. Instead of accessing knowledge directly through expanded awareness it is given to Cult operatives by the secret society networks of the Cult where it has been passed on over thousands of years outside the public arena. Expanded realms of consciousness is where great artists, composers and writers find their inspiration and where truth awaits anyone open enough to connect with it. We need to go there fast.

## **Archon hijack**

A fifth of the Nag Hammadi texts describe the existence and manipulation of the Archons led by a 'Chief Archon' they call 'Yaldabaoth', or the 'Demiurge', and this is the Christian 'Devil', 'Satan', 'Lucifer', and his demons. Archons in Biblical symbolism are the 'fallen ones' which are also referred to as fallen angels after the angels expelled from heaven according to the Abrahamic religions of Judaism, Christianity and Islam. These angels are claimed to tempt humans to 'sin' ongoing and you will see how accurate that symbolism is during the rest of the book. The theme of 'original sin' is related to the 'Fall' when Adam and Eve were 'tempted by the serpent' and fell from a state of innocence and 'obedience' (connection) with God into a state of disobedience (disconnection). The Fall is said to have brought sin into the world and corrupted everything including human nature. Yaldabaoth, the 'Lord Archon', is described by Gnostics as a 'counterfeit spirit', 'The Blind One', 'The Blind God', and 'The Foolish One'. The Jewish name for Yaldabaoth in Talmudic writings is Samael which translates as 'Poison of God', or 'Blindness of God'. You see the parallels. Yaldabaoth in Islamic belief is the Muslim Jinn devil known as Shaytan – Shaytan is Satan as the same themes are found all over the world in every religion and culture. The 'Lord God' of the Old Testament is the 'Lord Archon' of Gnostic manuscripts and that's why he's such a bloodthirsty bastard. Satan is known by Christians as 'the Demon of Demons' and Gnostics called Yaldabaoth the 'Archon of Archons'. Both are known as 'The Deceiver'. We are talking about the same 'bloke' for sure and these common themes

using different names, storylines and symbolism tell a common tale of the human plight.

Archons are referred to in Nag Hammadi documents as mind parasites, inverters, guards, gatekeepers, detainers, judges, pitiless ones and deceivers. The 'Covid' hoax alone is a glaring example of all these things. The Biblical 'God' is so different in the Old and New Testaments because they are not describing the same phenomenon. The vindictive, angry, hate-filled, 'God' of the Old Testament, known as Yahweh, is Yaldabaoth who is depicted in Cult-dictated popular culture as the 'Dark Lord', 'Lord of Time', Lord (Darth) Vader and Dormammu, the evil ruler of the 'Dark Dimension' trying to take over the 'Earth Dimension' in the Marvel comic movie, *Dr Strange*. Yaldabaoth is both the Old Testament 'god' and the Biblical 'Satan'. Gnostics referred to Yaldabaoth as the 'Great Architect of the Universe' and the Cult-controlled Freemason network calls their god 'the 'Great Architect of the Universe' (also Grand Architect). The 'Great Architect' Yaldabaoth is symbolised by the Cult as the all-seeing eye at the top of the pyramid on the Great Seal of the United States and the dollar bill. Archon is encoded in *arch*-itect as it is in *arch*-angels and *arch*-bishops. All religions have the theme of a force for good and force for evil in some sort of spiritual war and there is a reason for that – the theme is true. The Cult and its non-human masters are quite happy for this to circulate. They present themselves as the force for good fighting evil when they are really the force of evil (absence of love). The whole foundation of Cult modus operandi is inversion. They promote themselves as a force for good and anyone challenging them in pursuit of peace, love, fairness, truth and justice is condemned as a satanic force for evil. This has been the game plan throughout history whether the Church of Rome inquisitions of non-believers or 'conspiracy theorists' and 'anti-vaxxers' of today. The technique is the same whatever the timeline era.

**Yaldabaoth is revolting (true)**

Yaldabaoth and the Archons are said to have revolted against God with Yaldabaoth claiming to *be* God – the *All That Is*. The Old Testament ‘God’ (Yaldabaoth) demanded to be worshipped as such: ‘*I am the LORD, and there is none else, there is no God beside me*’ (Isaiah 45:5). I have quoted in other books a man who said he was the unofficial son of the late Baron Philippe de Rothschild of the Mouton-Rothschild wine producing estates in France who died in 1988 and he told me about the Rothschild ‘revolt from God’. The man said he was given the name Phillip Eugene de Rothschild and we shared long correspondence many years ago while he was living under another identity. He said that he was conceived through ‘occult incest’ which (within the Cult) was ‘normal and to be admired’. ‘Phillip’ told me about his experience attending satanic rituals with rich and famous people whom he names and you can see them and the wider background to Cult Satanism in my other books starting with *The Biggest Secret*. Cult rituals are interactions with Archontic ‘gods’. ‘Phillip’ described Baron Philippe de Rothschild as ‘a master Satanist and hater of God’ and he used the same term ‘revolt from God’ associated with Yaldabaoth/Satan/Lucifer/the Devil in describing the Sabbatian Rothschild dynasty. ‘I played a key role in my family’s revolt from God’, he said. That role was to infiltrate in classic Sabbatian style the Christian Church, but eventually he escaped the mind-prison to live another life. The Cult has been targeting religion in a plan to make worship of the Archons the global one-world religion. Infiltration of Satanism into modern ‘culture’, especially among the young, through music videos, stage shows and other means, is all part of this.

Nag Hammadi texts describe Yaldabaoth and the Archons in their prime form as energy – consciousness – and say they can take form if they choose in the same way that consciousness takes form as a human. Yaldabaoth is called ‘formless’ and represents a deeply inverted, distorted and chaotic state of consciousness which seeks to attach to humans and turn them into a likeness of itself in an attempt at assimilation. For that to happen it has to manipulate

humans into low frequency mental and emotional states that match its own. Archons can certainly appear in human form and this is the origin of the psychopathic personality. The energetic distortion Gnostics called Yaldabaoth is psychopathy. When psychopathic Archons take human form that human will be a psychopath as an expression of Yaldabaoth consciousness. Cult psychopaths are Archons in human form. The principle is the same as that portrayed in the 2009 *Avatar* movie when the American military travelled to a fictional Earth-like moon called Pandora in the Alpha Centauri star system to infiltrate a society of blue people, or Na'vi, by hiding within bodies that looked like the Na'vi. Archons posing as humans have a particular hybrid information field, part human, part Archon, (the ancient 'demigods') which processes information in a way that manifests behaviour to match their psychopathic evil, lack of empathy and compassion, and stops them being influenced by the empathy, compassion and love that a fully-human information field is capable of expressing. Cult bloodlines interbreed, be they royalty or dark suits, for this reason and you have their obsession with incest. Interbreeding with full-blown humans would dilute the Archontic energy field that guarantees psychopathy in its representatives in the human realm.

Gnostic writings say the main non-human forms that Archons take are *serpentine* (what I have called for decades 'reptilian' amid unbounded ridicule from the Archontically-programmed) and what Gnostics describe as 'an unborn baby or foetus with grey skin and dark, unmoving eyes'. This is an excellent representation of the ET 'Greys' of UFO folklore which large numbers of people claim to have seen and been abducted by – Zulu shaman Credo Mutwa among them. I agree with those that believe in extraterrestrial or interdimensional visitations today and for thousands of years past. No wonder with their advanced knowledge and technological capability they were perceived and worshipped as gods for technological and other 'miracles' they appeared to perform. Imagine someone arriving in a culture disconnected from the modern world with a smartphone and computer. They would be

seen as a 'god' capable of 'miracles'. The Renegade Mind, however, wants to know the source of everything and not only the way that source manifests as human or non-human. In the same way that a Renegade Mind seeks the original source material for the 'Covid virus' to see if what is claimed is true. The original source of Archons in form is consciousness – the distorted state of consciousness known to Gnostics as Yaldabaoth.

### **'Revolt from God' is energetic disconnection**

Where I am going next will make a lot of sense of religious texts and ancient legends relating to 'Satan', Lucifer' and the 'gods'. Gnostic descriptions sync perfectly with the themes of my own research over the years in how they describe a consciousness distortion seeking to impose itself on human consciousness. I've referred to the core of infinite awareness in previous books as Infinite Awareness in Awareness of Itself. By that I mean a level of awareness that knows that it is all awareness and is aware of all awareness. From here comes the frequency of love in its true sense and balance which is what love is on one level – the balance of all forces into a single whole called Oneness and Isness. The more we disconnect from this state of love that many call 'God' the constituent parts of that Oneness start to unravel and express themselves as a part and not a whole. They become individualised as intellect, mind, selfishness, hatred, envy, desire for power over others, and such like. This is not a problem in the greater scheme in that 'God', the *All That Is*, can experience all these possibilities through different expressions of itself including humans. What we as expressions of the whole experience the *All That Is* experiences. We are the *All That Is* experiencing itself. As we withdraw from that state of Oneness we disconnect from its influence and things can get very unpleasant and very stupid. Archontic consciousness is at the extreme end of that. It has so disconnected from the influence of Oneness that it has become an inversion of unity and love, an inversion of everything, an inversion of life itself. Evil is appropriately live written backwards. Archontic consciousness is obsessed with death, an inversion of life,



and so its manifestations in Satanism are obsessed with death. They use inverted symbols in their rituals such as the inverted pentagram and cross. Sabbatians as Archontic consciousness incarnate invert Judaism and every other religion and culture they infiltrate. They seek disunity and chaos and they fear unity and harmony as they fear love like garlic to a vampire. As a result the Cult, Archons incarnate, act with such evil, psychopathy and lack of empathy and compassion disconnected as they are from the source of love. How could Bill Gates and the rest of the Archontic psychopaths do what they have to human society in the 'Covid' era with all the death, suffering and destruction involved and have no emotional consequence for the impact on others? Now you know. Why have Zuckerberg, Brin, Page, Wojcicki and company callously censored information warning about the dangers of the 'vaccine' while thousands have been dying and having severe, sometimes life-changing reactions? Now you know. Why have Tedros, Fauci, Whitty, Vallance and their like around the world been using case and death figures they're aware are fraudulent to justify lockdowns and all the deaths and destroyed lives that have come from that? Now you know. Why did Christian Drosten produce and promote a 'testing' protocol that he knew couldn't test for infectious disease which led to a global human catastrophe. Now you know. The Archontic mind doesn't give a shit ([Fig 17](#)). I personally think that Gates and major Cult insiders are a form of AI cyborg that the Archons want humans to become.

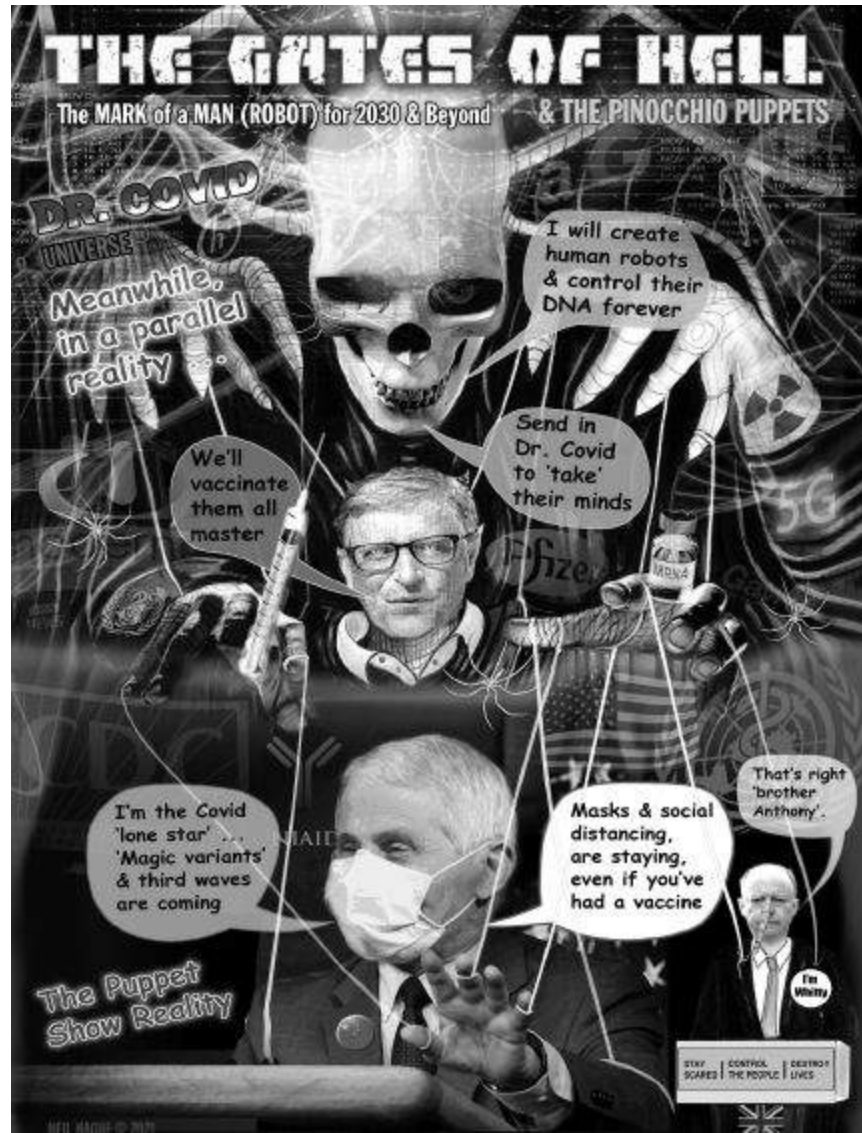


Figure 17: Artist Neil Hague's version of the 'Covid' hierarchy.

## Human batteries

A state of such inversion does have its consequences, however. The level of disconnection from the Source of All means that you withdraw from that source of energetic sustenance and creativity. This means that you have to find your own supply of energetic power and it has – us. When the Morpheus character in the first *Matrix* movie held up a battery he spoke a profound truth when he said: 'The Matrix is a computer-generated dream world built to keep us under control in order to change the human being into one of

these.’ The statement was true in all respects. We do live in a technologically-generated virtual reality simulation (more very shortly) and we have been manipulated to be an energy source for Archontic consciousness. The Disney-Pixar animated movie *Monsters, Inc.* in 2001 symbolised the dynamic when monsters in their world had no energy source and they would enter the human world to terrify children in their beds, catch the child’s scream, terror (low-vibrational frequencies), and take that energy back to power the monster world. The lead character you might remember was a single giant eye and the symbolism of the Cult’s all-seeing eye was obvious. Every thought and emotion is broadcast as a frequency unique to that thought and emotion. Feelings of love and joy, empathy and compassion, are high, quick, frequencies while fear, depression, anxiety, suffering and hate are low, slow, dense frequencies. Which kind do you think Archontic consciousness can connect with and absorb? In such a low and dense frequency state there’s no way it can connect with the energy of love and joy. Archons can only feed off energy compatible with their own frequency and they and their Cult agents want to delete the human world of love and joy and manipulate the transmission of low vibrational frequencies through low-vibrational human mental and emotional states. *We are their energy source.* Wars are energetic banquets to the Archons – a world war even more so – and think how much low-frequency mental and emotional energy has been generated from the consequences for humanity of the ‘Covid’ hoax orchestrated by Archons incarnate like Gates.

The ancient practice of human sacrifice ‘to the gods’, continued in secret today by the Cult, is based on the same principle. ‘The gods’ are Archontic consciousness in different forms and the sacrifice is induced into a state of intense terror to generate the energy the Archontic frequency can absorb. Incarnate Archons in the ritual drink the blood which contains an adrenaline they crave which floods into the bloodstream when people are terrorised. Most of the sacrifices, ancient and modern, are children and the theme of ‘sacrificing young virgins to the gods’ is just code for children. They

have a particular pre-puberty energy that Archons want more than anything and the energy of the young in general is their target. The California Department of Education wants students to chant the names of Aztec gods (Archontic gods) once worshipped in human sacrifice rituals in a curriculum designed to encourage them to 'challenge racist, bigoted, discriminatory, imperialist/colonial beliefs', join 'social movements that struggle for social justice', and 'build new possibilities for a post-racist, post-systemic racism society'. It's the usual Woke crap that inverts racism and calls it anti-racism. In this case solidarity with 'indigenous tribes' is being used as an excuse to chant the names of 'gods' to which people were sacrificed (and still are in secret). What an example of Woke's inability to see beyond black and white, us and them, They condemn the colonisation of these tribal cultures by Europeans (quite right), but those cultures sacrificing people including children to their 'gods', and mass murdering untold numbers as the Aztecs did, is just fine. One chant is to the Aztec god Tezcatlipoca who had a man sacrificed to him in the 5th month of the Aztec calendar. His heart was cut out and he was eaten. Oh, that's okay then. Come on children ... after three ... Other sacrificial 'gods' for the young to chant their allegiance include Quetzalcoatl, Huitzilopochtli and Xipe Totec. The curriculum says that 'chants, affirmations, and energizers can be used to bring the class together, build unity around ethnic studies principles and values, and to reinvigorate the class following a lesson that may be emotionally taxing or even when student engagement may appear to be low'. Well, that's the cover story, anyway. Chanting and mantras are the repetition of a particular frequency generated from the vocal cords and chanting the names of these Archontic 'gods' tunes you into their frequency. That is the last thing you want when it allows for energetic synchronisation, attachment and perceptual influence. Initiates chant the names of their 'Gods' in their rituals for this very reason.

## **Vampires of the Woke**

Paedophilia is another way that Archons absorb the energy of children. Paedophiles possessed by Archontic consciousness are used as the conduit during sexual abuse for discarnate Archons to vampire the energy of the young they desire so much. Stupendous numbers of children disappear every year never to be seen again although you would never know from the media. Imagine how much low-vibrational energy has been generated by children during the 'Covid' hoax when so many have become depressed and psychologically destroyed to the point of killing themselves. Shocking numbers of children are now taken by the state from loving parents to be handed to others. I can tell you from long experience of researching this since 1996 that many end up with paedophiles and assets of the Cult through corrupt and Cult-owned social services which in the reframing era has hired many psychopaths and emotionless automatons to do the job. Children are even stolen to order using spurious reasons to take them by the corrupt and secret (because they're corrupt) 'family courts'. I have written in detail in other books, starting with *The Biggest Secret* in 1997, about the ubiquitous connections between the political, corporate, government, intelligence and military elites (Cult operatives) and Satanism and paedophilia. If you go deep enough both networks have an interlocking leadership. The Woke mentality has been developed by the Cult for many reasons: To promote almost every aspect of its agenda; to hijack the traditional political left and turn it fascist; to divide and rule; and to target agenda pushbackers. But there are other reasons which relate to what I am describing here. How many happy and joyful Wokers do you ever see especially at the extreme end? They are a mental and psychological mess consumed by emotional stress and constantly emotionally cocked for the next explosion of indignation at someone referring to a female as a female. They are walking, talking, batteries as Morpheus might say emitting frequencies which both enslave them in low-vibrational bubbles of perceptual limitation and feed the Archons. Add to this the hatred claimed to be love; fascism claimed to 'anti-fascism', racism claimed to be 'anti-racism';

exclusion claimed to inclusion; and the abuse-filled Internet trolling. You have a purpose-built Archontic energy system with not a wind turbine in sight and all founded on Archontic *inversion*. We have whole generations now manipulated to serve the Archons with their actions and energy. They will be doing so their entire adult lives unless they snap out of their Archon-induced trance. Is it really a surprise that Cult billionaires and corporations put so much money their way? Where is the energy of joy and laughter, including laughing at yourself which is confirmation of your own emotional security? Mark Twain said: 'The human race has one really effective weapon, and that is laughter.' We must use it all the time. Woke has destroyed comedy because it has no humour, no joy, sense of irony, or self-deprecation. Its energy is dense and intense. *Mmmmm*, lunch says the Archontic frequency. Rudolf Steiner (1861-1925) was the Austrian philosopher and famous esoteric thinker who established Waldorf education or Steiner schools to treat children like unique expressions of consciousness and not minds to be programmed with the perceptions determined by authority. I'd been writing about this energy vampiring for decades when I was sent in 2016 a quote by Steiner. He was spot on:

There are beings in the spiritual realms for whom anxiety and fear emanating from human beings offer welcome food. When humans have no anxiety and fear, then these creatures starve. If fear and anxiety radiates from people and they break out in panic, then these creatures find welcome nutrition and they become more and more powerful. These beings are hostile towards humanity. Everything that feeds on negative feelings, on anxiety, fear and superstition, despair or doubt, are in reality hostile forces in super-sensible worlds, launching cruel attacks on human beings, while they are being fed ... These are exactly the feelings that belong to contemporary culture and materialism; because it estranges people from the spiritual world, it is especially suited to evoke hopelessness and fear of the unknown in people, thereby calling up the above mentioned hostile forces against them.

Pause for a moment from this perspective and reflect on what has happened in the world since the start of 2020. Not only will pennies drop, but billion dollar bills. We see the same theme from Don Juan Matus, a Yaqui Indian shaman in Mexico and the information source for Peruvian-born writer, Carlos Castaneda, who wrote a series of

books from the 1960s to 1990s. Don Juan described the force manipulating human society and his name for the Archons was the predator:

We have a predator that came from the depths of the cosmos and took over the rule of our lives. Human beings are its prisoners. The predator is our lord and master. It has rendered us docile, helpless. If we want to protest, it suppresses our protest. If we want to act independently, it demands that we don't do so ... indeed we are held prisoner!

They took us over because we are food to them, and they squeeze us mercilessly because we are their sustenance. Just as we rear chickens in coops, the predators rear us in human coops, humaneros. Therefore, their food is always available to them.

Different cultures, different eras, same recurring theme.

## **The 'ennoia' dilemma**

Nag Hammadi Gnostic manuscripts say that Archon consciousness has no 'ennoia'. This is directly translated as 'intentionality', but I'll use the term 'creative imagination'. The *All That Is* in awareness of itself is the source of all creativity – all possibility – and the more disconnected you are from that source the more you are subsequently denied 'creative imagination'. Given that Archon consciousness is almost entirely disconnected it severely lacks creativity and has to rely on far more mechanical processes of thought and exploit the creative potential of those that do have 'ennoia'. You can see cases of this throughout human society. Archon consciousness almost entirely dominates the global banking system and if we study how that system works you will appreciate what I mean. Banks manifest 'money' out of nothing by issuing lines of 'credit' which is 'money' that has never, does not, and will never exist except in theory. It's a confidence trick. If you think 'credit' figures-on-a-screen 'money' is worth anything you accept it as payment. If you don't then the whole system collapses through lack of confidence in the value of that 'money'. Archontic bankers with no 'ennoia' are 'lending' 'money' that doesn't exist to humans that *do* have creativity – those that have the inspired ideas and create businesses and products. Archon banking feeds off human creativity

which it controls through 'money' creation and debt. Humans have the creativity and Archons exploit that for their own benefit and control while having none themselves. Archon Internet platforms like Facebook claim joint copyright of everything that creative users post and while Archontic minds like Zuckerberg may officially head that company it will be human creatives on the staff that provide the creative inspiration. When you have limitless 'money' you can then buy other companies established by creative humans. Witness the acquisition record of Facebook, Google and their like. Survey the Archon-controlled music industry and you see non-creative dark suit executives making their fortune from the human creativity of their artists. The cases are endless. Research the history of people like Gates and Zuckerberg and how their empires were built on exploiting the creativity of others. Archon minds cannot create out of nothing, but they are skilled (because they have to be) in what Gnostic texts call 'countermimicry'. They can imitate, but not innovate. Sabbatians trawl the creativity of others through backdoors they install in computer systems through their cybersecurity systems. Archon-controlled China is globally infamous for stealing intellectual property and I remember how Hong Kong, now part of China, became notorious for making counterfeit copies of the creativity of others – 'countermimicry'. With the now pervasive and all-seeing surveillance systems able to infiltrate any computer you can appreciate the potential for Archons to vampire the creativity of humans. Author John Lamb Lash wrote in his book about the Nag Hammadi texts, *Not In His Image*:

Although they cannot originate anything, because they lack the divine factor of ennoia (intentionality), Archons can imitate with a vengeance. Their expertise is simulation (HAL, virtual reality). The Demiurge [Yaldabaoth] fashions a heaven world copied from the fractal patterns [of the original] ... His construction is celestial kitsch, like the fake Italianate villa of a Mafia don complete with militant angels to guard every portal.

This brings us to something that I have been speaking about since the turn of the millennium. Our reality is a simulation; a virtual reality that we think is real. No, I'm not kidding.



## **Human reality? Well, virtually**

I had pondered for years about whether our reality is 'real' or some kind of construct. I remembered being immensely affected on a visit as a small child in the late 1950s to the then newly-opened Planetarium on the Marylebone Road in London which is now closed and part of the adjacent Madame Tussauds wax museum. It was in the middle of the day, but when the lights went out there was the night sky projected in the Planetarium's domed ceiling and it appeared to be so real. The experience never left me and I didn't know why until around the turn of the millennium when I became certain that our 'night sky' and entire reality is a projection, a virtual reality, akin to the illusory world portrayed in the *Matrix* movies. I looked at the sky one day in this period and it appeared to me like the domed roof of the Planetarium. The release of the first *Matrix* movie in 1999 also provided a synchronistic and perfect visual representation of where my mind had been going for a long time. I hadn't come across the Gnostic Nag Hammadi texts then. When I did years later the correlation was once again astounding. As I read Gnostic accounts from 1,600 years and more earlier it was clear that they were describing the same simulation phenomenon. They tell how the Yaldabaoth 'Demiurge' and Archons created a 'bad copy' of original reality to rule over all that were captured by its illusions and the body was a prison to trap consciousness in the 'bad copy' fake reality. Read how Gnostics describe the 'bad copy' and update that to current times and they are referring to what we would call today a virtual reality simulation.

Author John Lamb Lash said 'the Demiurge fashions a heaven world copied from the fractal patterns' of the original through expertise in 'HAL' or virtual reality simulation. Fractal patterns are part of the energetic information construct of our reality, a sort of blueprint. If these patterns were copied in computer terms it would indeed give you a copy of a 'natural' reality in a non-natural frequency and digital form. The principle is the same as making a copy of a website. The original website still exists, but now you can change the copy version to make it whatever you like and it can

become very different to the original website. Archons have done this with our reality, a *synthetic* copy of prime reality that still exists beyond the frequency walls of the simulation. Trapped within the illusions of this synthetic Matrix, however, were and are human consciousness and other expressions of prime reality and this is why the Archons via the Cult are seeking to make the human body synthetic and give us synthetic AI minds to complete the job of turning the entire reality synthetic including what we perceive to be the natural world. To quote Kurzweil: 'Nanobots will infuse all the matter around us with information. Rocks, trees, everything will become these intelligent creatures.' Yes, *synthetic* 'creatures' just as 'Covid' and other genetically-manipulating 'vaccines' are designed to make the human body synthetic. From this perspective it is obvious why Archons and their Cult are so desperate to infuse synthetic material into every human with their 'Covid' scam.

### **Let there be (electromagnetic) light**

Yaldabaoth, the force that created the simulation, or Matrix, makes sense of the Gnostic reference to 'The Great Architect' and its use by Cult Freemasonry as the name of its deity. The designer of the Matrix in the movies is called 'The Architect' and that trilogy is jam-packed with symbolism relating to these subjects. I have contended for years that the angry Old Testament God (Yaldabaoth) is the 'God' being symbolically 'quoted' in the opening of Genesis as 'creating the world'. This is not the creation of prime reality – it's the creation of the *simulation*. The Genesis 'God' says: 'Let there be Light: and there was light.' But what is this 'Light'? I have said for decades that the speed of light (186,000 miles per second) is not the fastest speed possible as claimed by mainstream science and is in fact the frequency walls or outer limits of the Matrix. You can't have a fastest or slowest anything within all possibility when everything is possible. The human body is encoded to operate within the speed of light or *within the simulation* and thus we see only the tiny frequency band of visible *light*. Near-death experiencers who perceive reality outside the body during temporary 'death' describe a very different

form of light and this is supported by the Nag Hammadi texts. Prime reality beyond the simulation ('Upper Aeons' to the Gnostics) is described as a realm of incredible beauty, bliss, love and harmony – a realm of 'watery light' that is so powerful 'there are no shadows'. Our false reality of Archon control, which Gnostics call the 'Lower Aeons', is depicted as a realm with a different kind of 'light' and described in terms of chaos, 'Hell', 'the Abyss' and 'Outer Darkness', where trapped souls are tormented and manipulated by demons (relate that to the 'Covid' hoax alone). The watery light theme can be found in near-death accounts and it is not the same as *simulation* 'light' which is electromagnetic or radiation light within the speed of light – the 'Lower Aeons'. Simulation 'light' is the 'luminous fire' associated by Gnostics with the Archons. The Bible refers to Yaldabaoth as 'that old serpent, called the Devil, and Satan, which deceiveth the whole world' (Revelation 12:9). I think that making a simulated copy of prime reality ('countermimicry') and changing it dramatically while all the time manipulating humanity to believe it to be real could probably meet the criteria of deceiving the whole world. Then we come to the Cult god Lucifer – the *Light Bringer*. Lucifer is symbolic of Yaldabaoth, the bringer of radiation light that forms the bad copy simulation within the speed of light. 'He' is symbolised by the lighted torch held by the Statue of Liberty and in the name 'Illuminati'. Sabbatian-Frankism declares that Lucifer is the true god and Lucifer is the real god of Freemasonry honoured as their 'Great or Grand Architect of the Universe' (simulation).

I would emphasise, too, the way Archontic technologically-generated luminous fire of radiation has deluged our environment since I was a kid in the 1950s and changed the nature of The Field with which we constantly interact. Through that interaction technological radiation is changing us. The Smart Grid is designed to operate with immense levels of communication power with 5G expanding across the world and 6G, 7G, in the process of development. Radiation is the simulation and the Archontic manipulation system. Why wouldn't the Archon Cult wish to unleash radiation upon us to an ever-greater extreme to form

Kurzweil's 'cloud'? The plan for a synthetic human is related to the need to cope with levels of radiation beyond even anything we've seen so far. Biological humans would not survive the scale of radiation they have in their script. The Smart Grid is a technological sub-reality within the technological simulation to further disconnect five-sense perception from expanded consciousness. It's a technological prison of the mind.

### **Infusing the 'spirit of darkness'**

A recurring theme in religion and native cultures is the manipulation of human genetics by a non-human force and most famously recorded as the biblical 'sons of god' (the gods plural in the original) who interbred with the daughters of men. The Nag Hammadi *Apocryphon of John* tells the same story this way:

He [Yaldabaoth] sent his angels [Archons/demons] to the daughters of men, that they might take some of them for themselves and raise offspring for their enjoyment. And at first they did not succeed. When they had no success, they gathered together again and they made a plan together ... And the angels changed themselves in their likeness into the likeness of their mates, filling them with the spirit of darkness, which they had mixed for them, and with evil ... And they took women and begot children out of the darkness according to the likeness of their spirit.

Possession when a discarnate entity takes over a human body is an age-old theme and continues today. It's very real and I've seen it. Satanic and secret society rituals can create an energetic environment in which entities can attach to initiates and I've heard many stories of how people have changed their personality after being initiated even into lower levels of the Freemasons. I have been inside three Freemasonic temples, one at a public open day and two by just walking in when there was no one around to stop me. They were in Ryde, the town where I live, Birmingham, England, when I was with a group, and Boston, Massachusetts. They all felt the same energetically – dark, dense, low-vibrational and sinister. Demonic attachment can happen while the initiate has no idea what is going on. To them it's just a ritual to get in the Masons and do a bit of good

business. In the far more extreme rituals of Satanism human possession is even more powerful and they are designed to make possession possible. The hierarchy of the Cult is dictated by the power and perceived status of the possessing Archon. In this way the Archon hierarchy becomes the Cult hierarchy. Once the entity has attached it can influence perception and behaviour and if it attaches to the extreme then so much of its energy (information) infuses into the body information field that the hologram starts to reflect the nature of the possessing entity. This is the *Exorcist* movie type of possession when facial features change and it's known as shapeshifting. Islam's Jinn are said to be invisible tricksters who change shape, 'whisper', confuse and take human form. These are all traits of the Archons and other versions of the same phenomenon. Extreme possession could certainly infuse the 'spirit of darkness' into a partner during sex as the Nag Hammadi texts appear to describe. Such an infusion can change genetics which is also energetic information. Human genetics is information and the 'spirit of darkness' is information. Mix one with the other and change must happen. Islam has the concept of a 'Jinn baby' through possession of the mother and by Jinn taking human form. There are many ways that human genetics can be changed and remember that Archons have been aware all along of advanced techniques to do this. What is being done in human society today – and far more – was known about by Archons at the time of the 'fallen ones' and their other versions described in religions and cultures.

Archons and their human-world Cult are obsessed with genetics as we see today and they know this dictates how information is processed into perceived reality during a human life. They needed to produce a human form that would decode the simulation and this is symbolically known as 'Adam and Eve' who left the 'garden' (prime reality) and 'fell' into Matrix reality. The simulation is not a 'physical' construct (there is no 'physical'); it is a source of information. Think Wi-Fi again. The simulation is an energetic field encoded with information and body-brain systems are designed to decode that information encoded in wave or frequency form which

is transmitted to the brain as electrical signals. These are decoded by the brain to construct our sense of reality – an illusory ‘physical’ world that only exists in the brain or the mind. Virtual reality games mimic this process using the same sensory decoding system. Information is fed to the senses to decode a virtual reality that can appear so real, but isn’t (Figs 18 and 19). Some scientists believe – and I agree with them – that what we perceive as ‘physical’ reality only exists when we are looking or observing. The act of perception or focus triggers the decoding systems which turn waveform information into holographic reality. When we are not observing something our reality reverts from a holographic state to a waveform state. This relates to the same principle as a falling tree not making a noise unless someone is there to hear it or decode it. The concept makes sense from the simulation perspective. A computer is not decoding all the information in a Wi-Fi field all the time and only decodes or brings into reality on the screen that part of Wi-Fi that it’s decoding – focusing upon – at that moment.



**Figure 18:** Virtual reality technology ‘hacks’ into the body’s five-sense decoding system.



**Figure 19:** The result can be experienced as very ‘real’.

Interestingly, Professor Donald Hoffman at the Department of Cognitive Sciences at the University of California, Irvine, says that our experienced reality is like a computer interface that shows us only the level with which we interact while hiding all that exists beyond it: 'Evolution shaped us with a user interface that hides the truth. Nothing that we see is the truth – the very language of space and time and objects is the wrong language to describe reality.' He is correct in what he says on so many levels. Space and time are not a universal reality. They are a phenomenon of decoded *simulation* reality as part of the process of enslaving our sense of reality. Near-death experiencers report again and again how space and time did not exist as we perceive them once they were free of the body – body decoding systems. You can appreciate from this why Archons and their Cult are so desperate to entrap human attention in the five senses where we are in the Matrix and of the Matrix. Opening your mind to expanded states of awareness takes you beyond the information confines of the simulation and you become aware of knowledge and insights denied to you before. This is what we call 'awakening' – *awakening from the Matrix* – and in the final chapter I will relate this to current events.

## **Where are the 'aliens'?**

A simulation would explain the so-called 'Fermi Paradox' named after Italian physicist Enrico Fermi (1901-1954) who created the first nuclear reactor. He considered the question of why there is such a lack of extraterrestrial activity when there are so many stars and planets in an apparently vast universe; but what if the night sky that we see, or think we do, is a simulated projection as I say? If you control the simulation and your aim is to hold humanity fast in essential ignorance would you want other forms of life including advanced life coming and going sharing information with humanity? Or would you want them to believe they were isolated and apparently alone? Themes of human isolation and apartness are common whether they be the perception of a lifeless universe or the fascist isolation laws of the 'Covid' era. Paradoxically the very

existence of a simulation means that we are not alone when some force had to construct it. My view is that experiences that people have reported all over the world for centuries with Reptilians and Grey entities are Archon phenomena as Nag Hammadi texts describe; and that benevolent 'alien' interactions are non-human groups that come in and out of the simulation by overcoming Archon attempts to keep them out. It should be highlighted, too, that Reptilians and Greys are obsessed with *genetics* and *technology* as related by cultural accounts and those who say they have been abducted by them. Technology is their way of overcoming some of the limitations in their creative potential and our technology-driven and controlled human society of today is *archetypical* Archon-Reptilian-Grey modus operandi. Technocracy is really *Archontocracy*. The Universe does not have to be as big as it appears with a simulation. There is no space or distance only information decoded into holographic reality. What we call 'space' is only the absence of holographic 'objects' and that 'space' is The Field of energetic information which connects everything into a single whole. The same applies with the artificially-generated information field of the simulation. The Universe is not big or small as a physical reality. It is decoded information, that's all, and its perceived size is decided by the way the simulation is encoded to make it appear. The entire night sky as we perceive it only exists in our brain and so where are those 'millions of light years'? The 'stars' on the ceiling of the Planetarium looked a vast distance away.

There's another point to mention about 'aliens'. I have been highlighting since the 1990s the plan to stage a fake 'alien invasion' to justify the centralisation of global power and a world military. Nazi scientist Werner von Braun, who was taken to America by Operation Paperclip after World War Two to help found NASA, told his American assistant Dr Carol Rosin about the Cult agenda when he knew he was dying in 1977. Rosin said that he told her about a sequence that would lead to total human control by a one-world government. This included threats from terrorism, rogue nations, meteors and asteroids before finally an 'alien invasion'. All of these



things, von Braun said, would be bogus and what I would refer to as a No-Problem-Reaction-Solution. Keep this in mind when 'the aliens are coming' is the new mantra. The aliens are not coming – they are *already here* and they have infiltrated human society while looking human. French-Canadian investigative journalist Serge Monast said in 1994 that he had uncovered a NASA/military operation called Project Blue Beam which fits with what Werner von Braun predicted. Monast died of a 'heart attack' in 1996 the day after he was arrested and spent a night in prison. He was 51. He said Blue Beam was a plan to stage an alien invasion that would include religious figures beamed holographically into the sky as part of a global manipulation to usher in a 'new age' of worshipping what I would say is the Cult 'god' Yaldabaoth in a one-world religion. Fake holographic asteroids are also said to be part of the plan which again syncs with von Braun. How could you stage an illusory threat from asteroids unless they were holographic inserts? This is pretty straightforward given the advanced technology outside the public arena and the fact that our 'physical' reality is holographic anyway. Information fields would be projected and we would decode them into the illusion of a 'physical' asteroid. If they can sell a global 'pandemic' with a 'virus' that doesn't exist what will humans not believe if government and media tell them?

All this is particularly relevant as I write with the Pentagon planning to release in June, 2021, information about 'UFO sightings'. I have been following the UFO story since the early 1990s and the common theme throughout has been government and military denials and cover up. More recently, however, the Pentagon has suddenly become more talkative and apparently open with Air Force pilot radar images released of unexplained craft moving and changing direction at speeds well beyond anything believed possible with human technology. Then, in March, 2021, former Director of National Intelligence John Ratcliffe said a Pentagon report months later in June would reveal a great deal of information about UFO sightings unknown to the public. He said the report would have 'massive implications'. The order to do this was included bizarrely

in a \$2.3 trillion 'coronavirus' relief and government funding bill passed by the Trump administration at the end of 2020. I would add some serious notes of caution here. I have been pointing out since the 1990s that the US military and intelligence networks have long had craft – 'flying saucers' or anti-gravity craft – which any observer would take to be extraterrestrial in origin. Keeping this knowledge from the public allows craft flown by *humans* to be perceived as alien visitations. I am not saying that 'aliens' do not exist. I would be the last one to say that, but we have to be streetwise here. President Ronald Reagan told the UN General Assembly in 1987: 'I occasionally think how quickly our differences worldwide would vanish if we were facing an alien threat from outside this world.' That's the idea. Unite against a common 'enemy' with a common purpose behind your 'saviour force' (the Cult) as this age-old technique of mass manipulation goes global.

### **Science moves this way ...**

I could find only one other person who was discussing the simulation hypothesis publicly when I concluded it was real. This was Nick Bostrom, a Swedish-born philosopher at the University of Oxford, who has explored for many years the possibility that human reality is a computer simulation although his version and mine are not the same. Today the simulation and holographic reality hypothesis have increasingly entered the scientific mainstream. Well, the more open-minded mainstream, that is. Here are a few of the ever-gathering examples. American nuclear physicist Silas Beane led a team of physicists at the University of Bonn in Germany pursuing the question of whether we live in a simulation. They concluded that we probably do and it was likely based on a lattice of cubes. They found that cosmic rays align with that specific pattern. The team highlighted the Greisen–Zatsepin–Kuzmin (GZK) limit which refers to cosmic ray particle interaction with cosmic background radiation that creates an apparent boundary for cosmic ray particles. They say in a paper entitled 'Constraints on the Universe as a Numerical Simulation' that this 'pattern of constraint' is exactly what you

would find with a computer simulation. They also made the point that a simulation would create its own 'laws of physics' that would limit possibility. I've been making the same point for decades that the *perceived* laws of physics relate only to this reality, or what I would later call the simulation. When designers write codes to create computer and virtual reality games they are the equivalent of the laws of physics for that game. Players interact within the limitations laid out by the coding. In the same way those who wrote the codes for the simulation decided the laws of physics that would apply. These can be overridden by expanded states of consciousness, but not by those enslaved in only five-sense awareness where simulation codes rule. Overriding the codes is what people call 'miracles'. They are not. They are bypassing the encoded limits of the simulation. A population caught in simulation perception would have no idea that this was their plight. As the Bonn paper said: 'Like a prisoner in a pitch-black cell we would not be able to see the "walls" of our prison,' That's true if people remain mesmerised by the five senses. Open to expanded awareness and those walls become very clear. The main one is the speed of light.

American theoretical physicist James Gates is another who has explored the simulation question and found considerable evidence to support the idea. Gates was Professor of Physics at the University of Maryland, Director of The Center for String and Particle Theory, and on Barack Obama's Council of Advisors on Science and Technology. He and his team found *computer codes* of digital data embedded in the fabric of our reality. They relate to on-off electrical charges of 1 and 0 in the binary system used by computers. 'We have no idea what they are doing there', Gates said. They found within the energetic fabric mathematical sequences known as error-correcting codes or block codes that 'reboot' data to its original state or 'default settings' when something knocks it out of sync. Gates was asked if he had found a set of equations embedded in our reality indistinguishable from those that drive search engines and browsers and he said: 'That is correct.' Rich Terrile, director of the Centre for Evolutionary Computation and Automated Design at NASA's Jet

Propulsion Laboratory, has said publicly that he believes the Universe is a digital hologram that must have been created by a form of intelligence. I agree with that in every way. Waveform information is delivered electrically by the senses to the brain which constructs a *digital* holographic reality that we call the 'world'. This digital level of reality can be read by the esoteric art of numerology. Digital holograms are at the cutting edge of holographics today. We have digital technology everywhere designed to access and manipulate our digital level of perceived reality. Synthetic mRNA in 'Covid vaccines' has a digital component to manipulate the body's digital 'operating system'.

## **Reality is numbers**

How many know that our reality can be broken down to numbers and codes that are the same as computer games? Max Tegmark, a physicist at the Massachusetts Institute of Technology (MIT), is the author of *Our Mathematical Universe* in which he lays out how reality can be entirely described by numbers and maths in the way that a video game is encoded with the 'physics' of computer games. Our world and computer virtual reality are essentially the same.

Tegmark imagines the perceptions of characters in an advanced computer game when the graphics are so good they don't know they are in a game. They think they can bump into real objects (electromagnetic resistance in our reality), fall in love and feel emotions like excitement. When they began to study the apparently 'physical world' of the video game they would realise that everything was made of pixels (which have been found in our energetic reality as must be the case when on one level our world is digital). What computer game characters thought was physical 'stuff', Tegmark said, could actually be broken down into numbers:

And we're exactly in this situation in our world. We look around and it doesn't seem that mathematical at all, but everything we see is made out of elementary particles like quarks and electrons. And what properties does an electron have? Does it have a smell or a colour or a texture? No! ... We physicists have come up with geeky names for [Electron] properties, like

electric charge, or spin, or lepton number, but the electron doesn't care what we call it, the properties are just numbers.

This is the illusory reality Gnostics were describing. This is the simulation. The A, C, G, and T codes of DNA have a binary value – A and C = 0 while G and T = 1. This has to be when the simulation is digital and the body must be digital to interact with it. Recurring mathematical sequences are encoded throughout reality and the body. They include the Fibonacci sequence in which the two previous numbers are added to get the next one, as in ... 1, 1, 2, 3, 5, 8, 13, 21, 34, 55, etc. The sequence is encoded in the human face and body, proportions of animals, DNA, seed heads, pine cones, trees, shells, spiral galaxies, hurricanes and the number of petals in a flower. The list goes on and on. There are fractal patterns – a 'never-ending pattern that is infinitely complex and self-similar across all scales in the as above, so below, principle of holograms. These and other famous recurring geometrical and mathematical sequences such as Phi, Pi, Golden Mean, Golden Ratio and Golden Section are *computer codes* of the simulation. I had to laugh and give my head a shake the day I finished this book and it went into the production stage. I was sent an article in *Scientific American* published in April, 2021, with the headline 'Confirmed! We Live in a Simulation'. Two decades after I first said our reality is a simulation and the speed of light is its outer limit the article suggested that we do live in a simulation and that the speed of light is its outer limit. I left school at 15 and never passed a major exam in my life while the writer was up to his eyes in qualifications. As I will explain in the final chapter *knowing* is far better than thinking and they come from very different sources. The article rightly connected the speed of light to the processing speed of the 'Matrix' and said what has been in my books all this time ... 'If we are in a simulation, as it appears, then space is an abstract property written in code. It is not real'. No it's not and if we live in a simulation something created it and it wasn't *us*. 'That David Icke says we are manipulated by aliens' – he's crackers.'

## **Wow ...**

The reality that humanity thinks is so real is an illusion. Politicians, governments, scientists, doctors, academics, law enforcement, media, school and university curriculums, on and on, are all founded on a world that *does not exist* except as a simulated prison cell. Is it such a stretch to accept that 'Covid' doesn't exist when our entire 'physical' reality doesn't exist? Revealed here is the knowledge kept under raps in the Cult networks of compartmentalised secrecy to control humanity's sense of reality by inducing the population to believe in a reality that's not real. If it wasn't so tragic in its experiential consequences the whole thing would be hysterically funny. None of this is new to Renegade Minds. Ancient Greek philosopher Plato (about 428 to about 347BC) was a major influence on Gnostic belief and he described the human plight thousands of years ago with his Allegory of the Cave. He told the symbolic story of prisoners living in a cave who had never been outside. They were chained and could only see one wall of the cave while behind them was a fire that they could not see. Figures walked past the fire casting shadows on the prisoners' wall and those moving shadows became their sense of reality. Some prisoners began to study the shadows and were considered experts on them (today's academics and scientists), but what they studied was only an illusion (today's academics and scientists). A prisoner escaped from the cave and saw reality as it really is. When he returned to report this revelation they didn't believe him, called him mad and threatened to kill him if he tried to set them free. Plato's tale is not only a brilliant analogy of the human plight and our illusory reality. It describes, too, the dynamics of the 'Covid' hoax. I have only skimmed the surface of these subjects here. The aim of this book is to crisply connect all essential dots to put what is happening today into its true context. All subject areas and their connections in this chapter are covered in great evidential detail in *Everything You Need To Know, But Have Never Been Told* and *The Answer*.

They say that bewildered people 'can't see the forest for the trees'. Humanity, however, can't see the forest for the *twigs*. The five senses

see only twigs while Renegade Minds can see the forest and it's the forest where the answers lie with the connections that reveals. Breaking free of perceptual programming so the forest can be seen is the way we turn all this around. Not breaking free is how humanity got into this mess. The situation may seem hopeless, but I promise you it's not. We are a perceptual heartbeat from paradise if only we knew.

## CHAPTER TWELVE

### **Escaping Wetiko**

*Life is simply a vacation from the infinite*  
Dean Cavanagh

**R**enegade Minds weave the web of life and events and see common themes in the apparently random. They are always there if you look for them and their pursuit is aided by incredible synchronicity that comes when your mind is open rather than mesmerised by what it thinks it can see.

Infinite awareness is infinite possibility and the more of infinite possibility that we access the more becomes infinitely possible. That may be stating the apparently obvious, but it is a devastatingly-powerful fact that can set us free. We are a point of attention within an infinity of consciousness. The question is how much of that infinity do we choose to access? How much knowledge, insight, awareness, wisdom, do we want to connect with and explore? If your focus is only in the five senses you will be influenced by a fraction of infinite awareness. I mean a range so tiny that it gives new meaning to infinitesimal. Limitation of self-identity and a sense of the possible limit accordingly your range of consciousness. We are what we think we are. Life is what we think it is. The dream is the dreamer and the dreamer is the dream. Buddhist philosophy puts it this way: 'As a thing is viewed, so it appears.' Most humans live in the realm of touch, taste, see, hear, and smell and that's the limit of their sense of the possible and sense of self. Many will follow a religion and speak of a God in his heaven, but their lives are still



dominated by the five senses in their perceptions and actions. The five senses become the arbiter of everything. When that happens all except a smear of infinity is sealed away from influence by the rigid, unyielding, reality bubbles that are the five-sense human or Phantom Self. Archon Cult methodology is to isolate consciousness within five-sense reality – the simulation – and then program that consciousness with a sense of self and the world through a deluge of life-long information designed to instil the desired perception that allows global control. Efforts to do this have increased dramatically with identity politics as identity bubbles are squeezed into the minutiae of five-sense detail which disconnect people even more profoundly from the infinite 'I'.

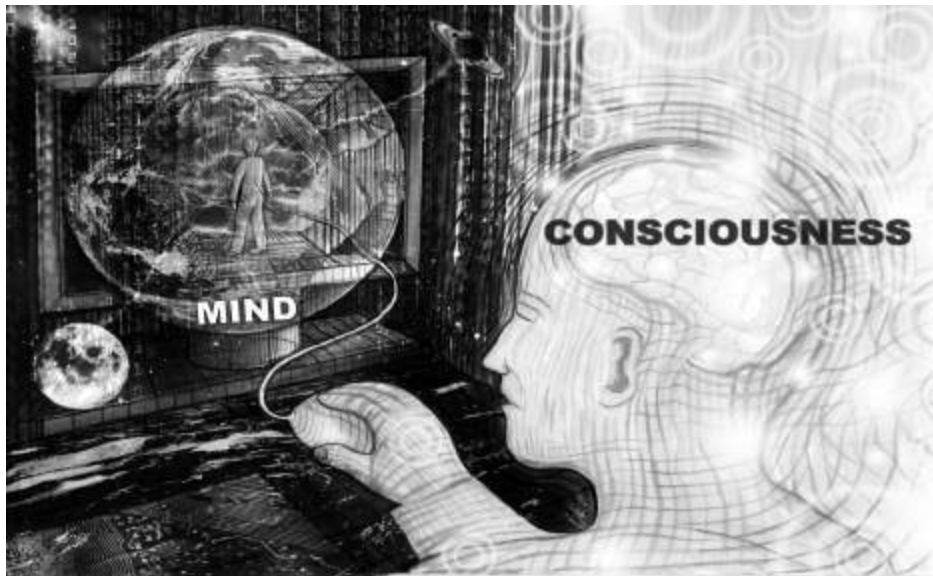
Five-sense focus and self-identity are like a firewall that limits access to the infinite realms. You only perceive one radio or television station and no other. We'll take that literally for a moment. Imagine a vast array of stations giving different information and angles on reality, but you only ever listen to one. Here we have the human plight in which the population is overwhelmingly confined to CultFM. This relates only to the frequency range of CultFM and limits perception and insight to that band – limits *possibility* to that band. It means you are connecting with an almost imperceptibly minuscule range of possibility and creative potential within the infinite Field. It's a world where everything seems apart from everything else and where synchronicity is rare. Synchronicity is defined in the dictionary as 'the happening by chance of two or more related or similar events at the same time'. Use of 'by chance' betrays a complete misunderstanding of reality. Synchronicity is not 'by chance'. As people open their minds, or 'awaken' to use the term, they notice more and more coincidences in their lives, bits of 'luck', apparently miraculous happenings that put them in the right place at the right time with the right people. Days become peppered with 'fancy meeting you here' and 'what are the chances of that?' My entire life has been lived like this and ever more so since my own colossal awakening in 1990 and 91 which transformed my sense of reality. Synchronicity is not 'by chance'; it is by accessing expanded

realms of possibility which allow expanded potential for manifestation. People broadcasting the same vibe from the same openness of mind tend to be drawn 'by chance' to each other through what I call frequency magnetism and it's not only people. In the last more than 30 years incredible synchronicity has also led me through the Cult maze to information in so many forms and to crucial personal experiences. These 'coincidences' have allowed me to put the puzzle pieces together across an enormous array of subjects and situations. Those who have breached the bubble of five-sense reality will know exactly what I mean and this escape from the perceptual prison cell is open to everyone whenever they make that choice. This may appear super-human when compared with the limitations of 'human', but it's really our natural state. 'Human' as currently experienced is consciousness in an unnatural state of induced separation from the infinity of the whole. I'll come to how this transformation into unity can be made when I have described in more detail the force that holds humanity in servitude by denying this access to infinite self.

### **The Wetiko factor**

I have been talking and writing for decades about the way five-sense mind is systematically barricaded from expanded awareness. I have used the analogy of a computer (five-sense mind) and someone at the keyboard (expanded awareness). Interaction between the computer and the operator is symbolic of the interaction between five-sense mind and expanded awareness. The computer directly experiences the Internet and the operator experiences the Internet via the computer which is how it's supposed to be – the two working as one. Archons seek to control that point where the operator connects with the computer to stop that interaction ([Fig 20](#)). Now the operator is banging the keyboard and clicking the mouse, but the computer is not responding and this happens when the computer is taken over – *possessed* – by an appropriately-named computer 'virus'. The operator has lost all influence over the computer which goes its own way making decisions under the control of the 'virus'. I have

just described the dynamic through which the force known to Gnostics as Yaldabaoth and Archons disconnects five-sense mind from expanded awareness to imprison humanity in perceptual servitude.



**Figure 20:** The mind ‘virus’ I have been writing about for decades seeks to isolate five-sense mind (the computer) from the true ‘I’. (Image by Neil Hague).

About a year ago I came across a Native American concept of Wetiko which describes precisely the same phenomenon. Wetiko is the spelling used by the Cree and there are other versions including wintiko and windigo used by other tribal groups. They spell the name with lower case, but I see Wetiko as a proper noun as with Archons and prefer a capital. I first saw an article about Wetiko by writer and researcher Paul Levy which so synced with what I had been writing about the computer/operator disconnection and later the Archons. I then read his book, the fascinating *Dispelling Wetiko, Breaking the Spell of Evil*. The parallels between what I had concluded long before and the Native American concept of Wetiko were so clear and obvious that it was almost funny. For Wetiko see the Gnostic Archons for sure and the Jinn, the Predators, and every other name for a force of evil, inversion and chaos. Wetiko is the Native American name for the force that divides the computer from

the operator (Fig 21). Indigenous author Jack D. Forbes, a founder of the Native American movement in the 1960s, wrote another book about Wetiko entitled *Columbus And Other Cannibals – The Wetiko Disease of Exploitation, Imperialism, and Terrorism* which I also read. Forbes says that Wetiko refers to an evil person or spirit ‘who terrorizes other creatures by means of terrible acts, including cannibalism’. Zulu shaman Credo Mutwa told me that African accounts tell how cannibalism was brought into the world by the Chitauri ‘gods’ – another manifestation of Wetiko. The distinction between ‘evil person or spirit’ relates to Archons/Wetiko possessing a human or acting as pure consciousness. Wetiko is said to be a sickness of the soul or spirit and a state of being that takes but gives nothing back – the Cult and its operatives perfectly described. Black Hawk, a Native American war leader defending their lands from confiscation, said European invaders had ‘poisoned hearts’ – Wetiko hearts – and that this would spread to native societies. Mention of the heart is very significant as we shall shortly see. Forbes writes: ‘Tragically, the history of the world for the past 2,000 years is, in great part, the story of the epidemiology of the wetiko disease.’ Yes, and much longer. Forbes is correct when he says: ‘The wetikos destroyed Egypt and Babylon and Athens and Rome and Tenochtitlan [capital of the Aztec empire] and perhaps now they will destroy the entire earth.’ Evil, he said, is the number one export of a Wetiko culture – see its globalisation with ‘Covid’. Constant war, mass murder, suffering of all kinds, child abuse, Satanism, torture and human sacrifice are all expressions of Wetiko and the Wetiko possessed. The world is Wetiko made manifest, *but it doesn’t have to be*. There is a way out of this even now.



**Figure 21:** The mind 'virus' is known to Native Americans as 'Wetiko'. (Image by Neil Hague).

## **Cult of Wetiko**

Wetiko is the Yaldabaoth frequency distortion that seeks to attach to human consciousness and absorb it into its own. Once this connection is made Wetiko can drive the perceptions of the target which they believe to be coming from their own mind. All the horrors of history and today from mass killers to Satanists, paedophiles like Jeffrey Epstein and other psychopaths, are the embodiment of Wetiko and express its state of being in all its grotesqueness. The Cult is Wetiko incarnate, Yaldabaoth incarnate, and it seeks to facilitate Wetiko assimilation of humanity in totality into its distortion by manipulating the population into low frequency states that match its own. Paul Levy writes: 'Holographically enforced within the psyche of every human being the wetiko virus pervades and underlies the entire field of consciousness, and can therefore potentially manifest through any one of us at any moment if we are not mindful.' The 'Covid' hoax has achieved this with many people, but others have not fallen into Wetiko's frequency lair. Players in the 'Covid' human catastrophe including Gates, Schwab, Tedros, Fauci, Whitty, Vallance, Johnson, Hancock, Ferguson, Drosten, and all the rest, including the psychopath psychologists, are expressions of Wetiko. This is why

they have no compassion or empathy and no emotional consequence for what they do that would make them stop doing it. Observe all the people who support the psychopaths in authority against the Pushbackers despite the damaging impact the psychopaths have on their own lives and their family's lives. You are again looking at Wetiko possession which prevents them seeing through the lies to the obvious scam going on. *Why can't they see it?* Wetiko won't let them see it. The perceptual divide that has now become a chasm is between the Wetikoed and the non-Wetikoed.

Paul Levy describes Wetiko in the same way that I have long described the Archontic force. They are the same distorted consciousness operating across dimensions of reality: '... the subtle body of wetiko is not located in the third dimension of space and time, literally existing in another dimension ... it is able to affect ordinary lives by mysteriously interpenetrating into our three-dimensional world.' Wetiko does this through its incarnate representatives in the Cult and by weaving itself into The Field which on our level of reality is the electromagnetic information field of the simulation or Matrix. More than that, the simulation *is* Wetiko / Yaldabaoth. Caleb Scharf, Director of Astrobiology at Columbia University, has speculated that 'alien life' could be so advanced that it has transcribed itself into the quantum realm to become what we call physics. He said intelligence indistinguishable from the fabric of the Universe would solve many of its greatest mysteries:

Perhaps hyper-advanced life isn't just external. Perhaps it's already all around. It is embedded in what we perceive to be physics itself, from the root behaviour of particles and fields to the phenomena of complexity and emergence ... In other words, life might not just be in the equations. It might BE the equations [My emphasis].

Scharf said it is possible that 'we don't recognise advanced life because it forms an integral and unsuspecting part of what we've considered to be the natural world'. I agree. Wetiko/Yaldabaoth *is* the simulation. We are literally in the body of the beast. But that doesn't mean it has to control us. We all have the power to overcome Wetiko

influence and the Cult knows that. I doubt it sleeps too well because it knows that.

## **Which Field?**

This, I suggest, is how it all works. There are two Fields. One is the fierce electromagnetic light of the Matrix within the speed of light; the other is the 'watery light' of The Field beyond the walls of the Matrix that connects with the Great Infinity. Five-sense mind and the decoding systems of the body attach us to the Field of Matrix light. They have to or we could not experience this reality. Five-sense mind sees only the Matrix Field of information while our expanded consciousness is part of the Infinity Field. When we open our minds, and most importantly our hearts, to the Infinity Field we have a mission control which gives us an expanded perspective, a road map, to understand the nature of the five-sense world. If we are isolated only in five-sense mind there is no mission control. We're on our own trying to understand a world that's constantly feeding us information to ensure we do not understand. People in this state can feel 'lost' and bewildered with no direction or radar. You can see ever more clearly those who are influenced by the Fields of Big Infinity or little five-sense mind simply by their views and behaviour with regard to the 'Covid' hoax. We have had this division throughout known human history with the mass of the people on one side and individuals who could see and intuit beyond the walls of the simulation – Plato's prisoner who broke out of the cave and saw reality for what it is. Such people have always been targeted by Wetiko/Archon-possessed authority, burned at the stake or demonised as mad, bad and dangerous. The Cult today and its global network of 'anti-hate', 'anti-fascist' Woke groups are all expressions of Wetiko attacking those exposing the conspiracy, 'Covid' lies and the 'vaccine' agenda.

Woke as a whole is Wetiko which explains its black and white mentality and how at one it is with the Wetiko-possessed Cult. Paul Levy said: 'To be in this paradigm is to still be under the thrall of a two-valued logic – where things are either true or false – of a

wetikoized mind.’ Wetiko consciousness is in a permanent rage, therefore so is Woke, and then there is Woke inversion and contradiction. ‘Anti-fascists’ act like fascists because fascists *and* ‘anti-fascists’ are both Wetiko at work. Political parties act the same while claiming to be different for the same reason. Secret society and satanic rituals are attaching initiates to Wetiko and the cold, ruthless, psychopathic mentality that secures the positions of power all over the world is Wetiko. Reframing ‘training programmes’ have the same cumulative effect of attaching Wetiko and we have their graduates described as automatons and robots with a cold, psychopathic, uncaring demeanour. They are all traits of Wetiko possession and look how many times they have been described in this book and elsewhere with regard to personnel behind ‘Covid’ including the police and medical profession. Climbing the greasy pole in any profession in a Wetiko society requires traits of Wetiko to get there and that is particularly true of politics which is not about fair competition and pre-eminence of ideas. It is founded on how many backs you can stab and arses you can lick. This culminated in the global ‘Covid’ coordination between the Wetiko possessed who pulled it off in all the different countries without a trace of empathy and compassion for their impact on humans. Our sight sense can see only holographic form and not the Field which connects holographic form. Therefore we perceive ‘physical’ objects with ‘space’ in between. In fact that ‘space’ is energy/consciousness operating on multiple frequencies. One of them is Wetiko and that connects the Cult psychopaths, those who submit to the psychopaths, and those who serve the psychopaths in the media operations of the world. Wetiko is Gates. Wetiko is the mask-wearing submissive. Wetiko is the fake journalist and ‘fact-checker’. The Wetiko Field is coordinating the whole thing. Psychopaths, gofers, media operatives, ‘anti-hate’ hate groups, ‘fact-checkers’ and submissive people work as one unit *even without human coordination* because they are attached to the *same* Field which is organising it all (Fig 22). Paul Levy is here describing how Wetiko-possessed people are drawn together and refuse to let any information breach their rigid

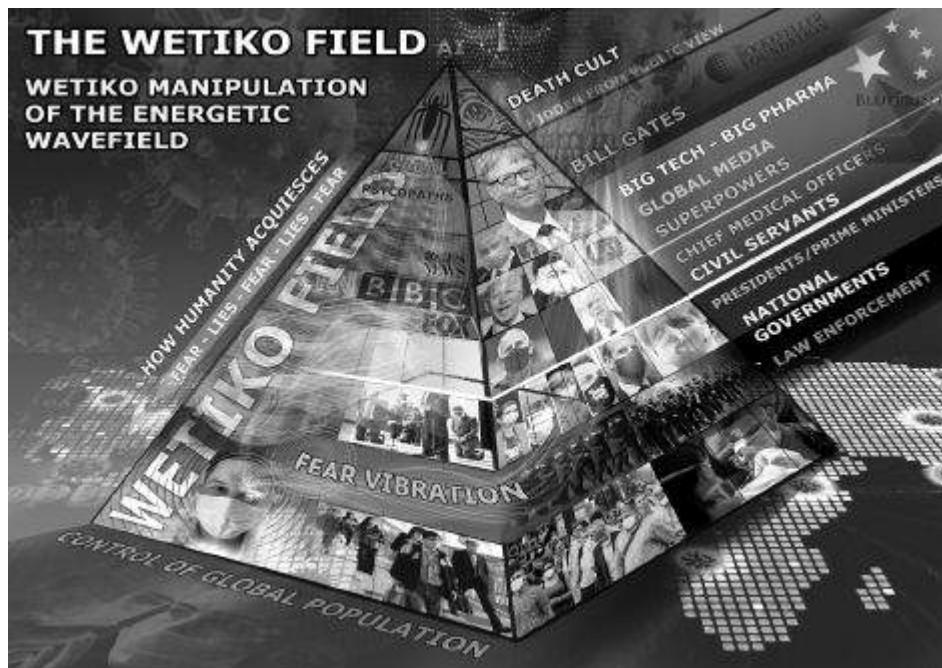


perceptions. He was writing long before 'Covid', but I think you will recognise followers of the 'Covid' religion *oh just a little bit*:

People who are channelling the vibratory frequency of wetiko align with each other through psychic resonance to reinforce their unspoken shared agreement so as to uphold their deranged view of reality. Once an unconscious content takes possession of certain individuals, it irresistibly draws them together by mutual attraction and knits them into groups tied together by their shared madness that can easily swell into an avalanche of insanity.

A psychic epidemic is a closed system, which is to say that it is insular and not open to any new information or informing influences from the outside world which contradict its fixed, limited, and limiting perspective.

There we have the Woke mind and the 'Covid' mind. Compatible resonance draws the awakening together, too, which is clearly happening today.



**Figure 22:** The Wetiko Field from which the Cult pyramid and its personnel are made manifest. (Image by Neil Hague).

## **Spiritual servitude**

Wetiko doesn't care about humans. It's not human; it just possesses humans for its own ends and the effect (depending on the scale of

possession) can be anything from extreme psychopathy to unquestioning obedience. Wetiko's worst nightmare is for human consciousness to expand beyond the simulation. Everything is focussed on stopping that happening through control of information, thus perception, thus frequency. The 'education system', media, science, medicine, academia, are all geared to maintaining humanity in five-sense servitude as is the constant stimulation of low-vibrational mental and emotional states (see 'Covid'). Wetiko seeks to dominate those subconscious spaces between five-sense perception and expanded consciousness where the computer meets the operator. From these subconscious hiding places Wetiko speaks to us to trigger urges and desires that we take to be our own and manipulate us into anything from low-vibrational to psychopathic states. Remember how Islam describes the Jinn as invisible tricksters that 'whisper' and confuse. Wetiko is the origin of the 'trickster god' theme that you find in cultures all over the world. Jinn, like the Archons, are Wetiko which is terrified of humans awakening and reconnecting with our true self for then its energy source has gone. With that the feedback loop breaks between Wetiko and human perception that provides the energetic momentum on which its very existence depends as a force of evil. Humans are both its target and its source of survival, but only if we are operating in low-vibrational states of fear, hate, depression and the background anxiety that most people suffer. We are Wetiko's target because we are its key to survival. It needs us, not the other way round. Paul Levy writes:

A vampire has no intrinsic, independent, substantial existence in its own right; it only exists in relation to us. The pathogenic, vampiric mind-parasite called wetiko is nothing in itself – not being able to exist from its own side – yet it has a 'virtual reality' such that it can potentially destroy our species ...

...The fact that a vampire is not reflected by a mirror can also mean that what we need to see is that there's nothing, no-thing to see, other than ourselves. The fact that wetiko is the expression of something inside of us means that the cure for wetiko is with us as well. The critical issue is finding this cure within us and then putting it into effect.

Evil begets evil because if evil does not constantly expand and find new sources of energetic sustenance its evil, its *distortion*, dies with the assimilation into balance and harmony. Love is the garlic to Wetiko's vampire. Evil, the absence of love, cannot exist in the presence of love. I think I see a way out of here. I have emphasised so many times over the decades that the Archons/Wetiko and their Cult are not all powerful. *They are not*. I don't care how it looks even now *they are not*. I have not called them little boys in short trousers for effect. I have said it because it is true. Wetiko's insatiable desire for power over others is not a sign of its omnipotence, but its insecurity. Paul Levy writes: 'Due to the primal fear which ultimately drives it and which it is driven to cultivate, wetiko's body politic has an intrinsic and insistent need for centralising power and control so as to create imagined safety for itself.' *Yeaaaaees!* Exactly! Why does Wetiko want humans in an ongoing state of fear? Wetiko itself *is* fear and it is petrified of love. As evil is an absence of love, so love is an absence of fear. Love conquers all and *especially* Wetiko which *is* fear. Wetiko brought fear into the world when it wasn't here before. *Fear* was the 'fall', the fall into low-frequency ignorance and illusion – fear is **False Emotion Appearing Real**. The simulation is driven and energised by fear because Wetiko/Yaldabaoth (fear) *are* the simulation. Fear is the absence of love and Wetiko is the absence of love.

## **Wetiko today**

We can now view current events from this level of perspective. The 'Covid' hoax has generated momentous amounts of ongoing fear, anxiety, depression and despair which have empowered Wetiko. No wonder people like Gates have been the instigators when they are Wetiko incarnate and exhibit every trait of Wetiko in the extreme. See how cold and unemotional these people are like Gates and his cronies, how dead of eye they are. That's Wetiko. Sabbatians are Wetiko and everything they control including the World Health Organization, Big Pharma and the 'vaccine' makers, national 'health'

hierarchies, corporate media, Silicon Valley, the banking system, and the United Nations with its planned transformation into world government. All are controlled and possessed by the Wetiko distortion into distorting human society in its image. We are with this knowledge at the gateway to understanding the world. Divisions of race, culture, creed and sexuality are diversions to hide the real division between those possessed and influenced by Wetiko and those that are not. The 'Covid' hoax has brought both clearly into view. Human behaviour is not about race. Tyrants and dictatorships come in all colours and creeds. What unites the US president bombing the innocent and an African tribe committing genocide against another as in Rwanda? What unites them? *Wetiko*. All wars are Wetiko, all genocide is Wetiko, all hunger over centuries in a world of plenty is Wetiko. Children going to bed hungry, including in the West, is Wetiko. Cult-generated Woke racial divisions that focus on the body are designed to obscure the reality that divisions in behaviour are manifestations of mind, not body. Obsession with body identity and group judgement is a means to divert attention from the real source of behaviour – mind and perception. Conflict sown by the Woke both within themselves and with their target groups are Wetiko providing lunch for itself through still more agents of the division, chaos, and fear on which it feeds. The Cult is seeking to assimilate the entirety of humanity and all children and young people into the Wetiko frequency by manipulating them into states of fear and despair. Witness all the suicide and psychological unravelling since the spring of 2020. Wetiko psychopaths want to impose a state of unquestioning obedience to authority which is no more than a conduit for Wetiko to enforce its will and assimilate humanity into itself. It needs us to believe that resistance is futile when it fears resistance and even more so the game-changing non-cooperation with its impositions. It can use violent resistance for its benefit. Violent impositions and violent resistance are *both* Wetiko. The Power of Love with its Power of No will sweep Wetiko from our world. Wetiko and its Cult know that. They just don't want us to know.

## **AI Wetiko**

This brings me to AI or artificial intelligence and something else Wetikos don't want us to know. What is AI *really*? I know about computer code algorithms and AI that learns from data input. These, however, are more diversions, the expeditionary force, for the real AI that they want to connect to the human brain as promoted by Silicon Valley Wetikos like Kurzweil. What is this AI? It is the frequency of *Wetiko*, the frequency of the Archons. The connection of AI to the human brain is the connection of the Wetiko frequency to create a Wetiko hive mind and complete the job of assimilation. The hive mind is planned to be controlled from Israel and China which are both 100 percent owned by Wetiko Sabbatians. The assimilation process has been going on minute by minute in the 'smart' era which fused with the 'Covid' era. We are told that social media is scrambling the minds of the young and changing their personality. This is true, but what is social media? Look more deeply at how it works, how it creates divisions and conflict, the hostility and cruelty, the targeting of people until they are destroyed. That's Wetiko. Social media is manipulated to tune people to the Wetiko frequency with all the emotional exploitation tricks employed by platforms like Facebook and its Wetiko front man, Zuckerberg. Facebook's Instagram announced a new platform for children to overcome a legal bar on them using the main site. This is more Wetiko exploitation and manipulation of kids. Amnesty International likened the plan to foxes offering to guard the henhouse and said it was incompatible with human rights. Since when did Wetiko or Zuckerberg (I repeat myself) care about that? Would Brin and Page at Google, Wojcicki at YouTube, Bezos at Amazon and whoever the hell runs Twitter act as they do if they were not channelling Wetiko? Would those who are developing technologies for no other reason than human control? How about those designing and selling technologies to kill people and Big Pharma drug and 'vaccine' producers who know they will end or devastate lives? Quite a thought for these people to consider is that if you are Wetiko in a human life you are Wetiko on the 'other side' unless your frequency

changes and that can only change by a change of perception which becomes a change of behaviour. Where Gates is going does not bear thinking about although perhaps that's exactly where he wants to go. Either way, that's where he's going. His frequency will make it so.

## **The frequency lair**

I have been saying for a long time that a big part of the addiction to smartphones and devices is that a frequency is coming off them that entraps the mind. People spend ages on their phones and sometimes even a minute or so after they put them down they pick them up again and it all repeats. 'Covid' lockdowns will have increased this addiction a million times for obvious reasons. Addictions to alcohol overindulgence and drugs are another way that Wetiko entraps consciousness to attach to its own. Both are symptoms of low-vibrational psychological distress which alcoholism and drug addiction further compound. Do we think it's really a coincidence that access to them is made so easy while potions that can take people into realms beyond the simulation are banned and illegal? I have explored smartphone addiction in other books, the scale is mind-blowing, and that level of addiction does not come without help. Tech companies that make these phones are Wetiko and they will have no qualms about destroying the minds of children. We are seeing again with these companies the Wetiko perceptual combination of psychopathic enforcers and weak and meek unquestioning compliance by the rank and file.

The global Smart Grid is the Wetiko Grid and it is crucial to complete the Cult endgame. The simulation is radiation and we are being deluged with technological radiation on a devastating scale. Wetiko frauds like Elon Musk serve Cult interests while occasionally criticising them to maintain his street-cred. 5G and other forms of Wi-Fi are being directed at the earth from space on a volume and scale that goes on increasing by the day. Elon Musk's (officially) SpaceX Starlink project is in the process of putting tens of thousands of satellites in low orbit to cover every inch of the planet with 5G and other Wi-Fi to create Kurzweil's global 'cloud' to which the

human mind is planned to be attached very soon. SpaceX has approval to operate 12,000 satellites with more than 1,300 launched at the time of writing and applications filed for 30,000 more. Other operators in the Wi-Fi, 5G, low-orbit satellite market include OneWeb (UK), Telesat (Canada), and AST & Science (US). Musk tells us that AI could be the end of humanity and then launches a company called Neuralink to connect the human brain to computers. Musk's (in theory) Tesla company is building electric cars and the driverless vehicles of the smart control grid. As frauds and bullshitters go Elon Musk in my opinion is Major League.

5G and technological radiation in general are destructive to human health, genetics and psychology and increasing the strength of artificial radiation underpins the five-sense perceptual bubbles which are themselves expressions of radiation or electromagnetism. Freedom activist John Whitehead was so right with his 'databit by databit, we are building our own electronic concentration camps'. The Smart Grid and 5G is a means to control the human mind and infuse perceptual information into The Field to influence anyone in sync with its frequency. You can change perception and behaviour en masse if you can manipulate the population into those levels of frequency and this is happening all around us today. The arrogance of Musk and his fellow Cult operatives knows no bounds in the way that we see with Gates. Musk's satellites are so many in number already they are changing the night sky when viewed from Earth. The astronomy community has complained about this and they have seen nothing yet. Some consequences of Musk's Wetiko hubris include: Radiation; visible pollution of the night sky; interference with astronomy and meteorology; ground and water pollution from intensive use of increasingly many spaceports; accumulating space debris; continual deorbiting and burning up of aging satellites, polluting the atmosphere with toxic dust and smoke; and ever-increasing likelihood of collisions. A collective public open letter of complaint to Musk said:

We are writing to you ... because SpaceX is in process of surrounding the Earth with a network of thousands of satellites whose very purpose is to irradiate every square inch of the

Earth. SpaceX, like everyone else, is treating the radiation as if it were not there. As if the mitochondria in our cells do not depend on electrons moving undisturbed from the food we digest to the oxygen we breathe.

As if our nervous systems and our hearts are not subject to radio frequency interference like any piece of electronic equipment. As if the cancer, diabetes, and heart disease that now afflict a majority of the Earth's population are not metabolic diseases that result from interference with our cellular machinery. As if insects everywhere, and the birds and animals that eat them, are not starving to death as a result.

People like Musk and Gates believe in their limitless Wetiko arrogance that they can do whatever they like to the world because they own it. Consequences for humanity are irrelevant. It's absolutely time that we stopped taking this shit from these self-styled masters of the Earth when you consider where this is going.

## **Why is the Cult so anti-human?**

I hear this question often: Why would they do this when it will affect them, too? Ah, but will it? Who is this *them*? Forget their bodies. They are just vehicles for Wetiko consciousness. When you break it all down to the foundations we are looking at a state of severely distorted consciousness targeting another state of consciousness for assimilation. The rest is detail. The simulation is the fly-trap in which unique sensations of the five senses create a cycle of addiction called reincarnation. Renegade Minds see that everything which happens in our reality is a smaller version of the whole picture in line with the holographic principle. Addiction to the radiation of smart technology is a smaller version of addiction to the whole simulation. Connecting the body/brain to AI is taking that addiction on a giant step further to total ongoing control by assimilating human incarnate consciousness into Wetiko. I have watched during the 'Covid' hoax how many are becoming ever more profoundly attached to Wetiko's perceptual calling cards of aggressive response to any other point of view ('There is no other god but me'), psychopathic lack of compassion and empathy, and servile submission to the narrative and will of authority. Wetiko is the psychopaths *and* subservience to psychopaths. The Cult of Wetiko is



so anti-human because it is *not* human. It embarked on a mission to destroy human by targeting everything that it means to be human and to survive as human. 'Covid' is not the end, just a means to an end. The Cult with its Wetiko consciousness is seeking to change Earth systems, including the atmosphere, to suit them, not humans. The gathering bombardment of 5G alone from ground and space is dramatically changing The Field with which the five senses interact. There is so much more to come if we sit on our hands and hope it will all go away. It is not meant to go away. It is meant to get ever more extreme and we need to face that while we still can – just.

Carbon dioxide is the gas of life. Without that human is over. Kaput, gone, history. No natural world, no human. The Cult has created a cock and bull story about carbon dioxide and climate change to justify its reduction to the point where Gates and the ignoramus Biden 'climate chief' John Kerry want to suck it out of the atmosphere. Kerry wants to do this because his master Gates does. Wetikos have made the gas of life a demon with the usual support from the Wokers of Extinction Rebellion and similar organisations and the bewildered puppet-child that is Greta Thunberg who was put on the world stage by Klaus Schwab and the World Economic Forum. The name Extinction Rebellion is both ironic and as always Wetiko inversion. The gas that we need to survive must be reduced to save us from extinction. The most basic need of human is oxygen and we now have billions walking around in face nappies depriving body and brain of this essential requirement of human existence. More than that 5G at 60 gigahertz interacts with the oxygen molecule to reduce the amount of oxygen the body can absorb into the bloodstream. The obvious knock-on consequences of that for respiratory and cognitive problems and life itself need no further explanation. Psychopaths like Musk are assembling a global system of satellites to deluge the human atmosphere with this insanity. The man should be in jail. Here we have two most basic of human needs, oxygen and carbon dioxide, being dismantled.

Two others, water and food, are getting similar treatment with the United Nations Agendas 21 and 2030 – the Great Reset – planning to

centrally control all water and food supplies. People will not even own rain water that falls on their land. Food is affected at the most basic level by reducing carbon dioxide. We have genetic modification or GMO infiltrating the food chain on a mass scale, pesticides and herbicides polluting the air and destroying the soil. Freshwater fish that provide livelihoods for 60 million people and feed hundreds of millions worldwide are being 'pushed to the brink' according the conservationists while climate change is the only focus. Now we have Gates and Schwab wanting to dispense with current food sources all together and replace them with a synthetic version which the Wetiko Cult would control in terms of production and who eats and who doesn't. We have been on the Totalitarian Tiptoe to this for more than 60 years as food has become ever more processed and full of chemical shite to the point today when it's not natural food at all. As Dr Tom Cowan says: 'If it has a label don't eat it.' Bill Gates is now the biggest owner of farmland in the United States and he does nothing without an ulterior motive involving the Cult. Klaus Schwab wrote: 'To feed the world in the next 50 years we will need to produce as much food as was produced in the last 10,000 years ... food security will only be achieved, however, if regulations on genetically modified foods are adapted to reflect the reality that gene editing offers a precise, efficient and safe method of improving crops.' Liar. People and the world are being targeted with aluminium through vaccines, chemtrails, food, drink cans, and endless other sources when aluminium has been linked to many health issues including dementia which is increasing year after year. Insects, bees and wildlife essential to the food chain are being deleted by pesticides, herbicides and radiation which 5G is dramatically increasing with 6G and 7G to come. The pollinating bee population is being devastated while wildlife including birds, dolphins and whales are having their natural radar blocked by the effects of ever-increasing radiation. In the summer windscreens used to be splattered with insects so numerous were they. It doesn't happen now. Where have they gone?

## **Synthetic everything**

The Cult is introducing genetically-modified versions of trees, plants and insects including a Gates-funded project to unleash hundreds of millions of genetically-modified, lab-altered and patented male mosquitoes to mate with wild mosquitoes and induce genetic flaws that cause them to die out. Clinically-insane Gates-funded Japanese researchers have developed mosquitos that spread vaccine and are dubbed 'flying vaccinators'. Gates is funding the modification of weather patterns in part to sell the myth that this is caused by carbon dioxide and he's funding geoengineering of the skies to change the atmosphere. Some of this came to light with the Gates-backed plan to release tonnes of chalk into the atmosphere to 'deflect the Sun and cool the planet'. Funny how they do this while the heating effect of the Sun is not factored into climate projections focussed on carbon dioxide. The reason is that they want to reduce carbon dioxide (so don't mention the Sun), but at the same time they do want to reduce the impact of the Sun which is so essential to human life and health. I have mentioned the sun-cholesterol-vitamin D connection as they demonise the Sun with warnings about skin cancer (caused by the chemicals in sun cream they tell you to splash on). They come from the other end of the process with statin drugs to reduce cholesterol that turns sunlight into vitamin D. A lack of vitamin D leads to a long list of health effects and how vitamin D levels must have fallen with people confined to their homes over 'Covid'. Gates is funding other forms of geoengineering and most importantly chemtrails which are dropping heavy metals, aluminium and self-replicating nanotechnology onto the Earth which is killing the natural world. See *Everything You Need To Know, But Have Never Been Told* for the detailed background to this.

Every human system is being targeted for deletion by a force that's not human. The Wetiko Cult has embarked on the process of transforming the human body from biological to synthetic biological as I have explained. Biological is being replaced by the artificial and synthetic – Archontic 'countermimicry' – right across human society. The plan eventually is to dispense with the human body altogether

and absorb human consciousness – which it wouldn't really be by then – into cyberspace (the simulation which is Wetiko/Yaldabaoth). Preparations for that are already happening if people would care to look. The alternative media rightly warns about globalism and 'the globalists', but this is far bigger than that and represents the end of the human race as we know it. The 'bad copy' of prime reality that Gnostics describe was a bad copy of harmony, wonder and beauty to start with before Wetiko/Yaldabaoth set out to change the simulated 'copy' into something very different. The process was slow to start with. Entrapped humans in the simulation timeline were not technologically aware and they had to be brought up to intellectual speed while being suppressed spiritually to the point where they could build their own prison while having no idea they were doing so. We have now reached that stage where technological intellect has the potential to destroy us and that's why events are moving so fast. Central American shaman Don Juan Matus said:

Think for a moment, and tell me how you would explain the contradictions between the intelligence of man the engineer and the stupidity of his systems of belief, or the stupidity of his contradictory behaviour. Sorcerers believe that the predators have given us our systems of beliefs, our ideas of good and evil; our social mores. They are the ones who set up our dreams of success or failure. They have given us covetousness, greed, and cowardice. It is the predator who makes us complacent, routinary, and egomaniacal.

In order to keep us obedient and meek and weak, the predators engaged themselves in a stupendous manoeuvre – stupendous, of course, from the point of view of a fighting strategist; a horrendous manoeuvre from the point of those who suffer it. They gave us their mind. The predators' mind is baroque, contradictory, morose, filled with the fear of being discovered any minute now.

For 'predators' see Wetiko, Archons, Yaldabaoth, Jinn, and all the other versions of the same phenomenon in cultures and religions all over the world. The theme is always the same because it's true and it's real. We have reached the point where we have to deal with it. The question is – how?

**Don't fight – walk away**

I thought I'd use a controversial subheading to get things moving in terms of our response to global fascism. What do you mean 'don't fight'? What do you mean 'walk away'? We've got to fight. We can't walk away. Well, it depends what we mean by fight and walk away. If fighting means physical combat we are playing Wetiko's game and falling for its trap. It wants us to get angry, aggressive, and direct hate and hostility at the enemy we think we must fight. Every war, every battle, every conflict, has been fought with Wetiko leading both sides. It's what it does. Wetiko wants a fight, anywhere, any place. Just hit me, son, so I can hit you back. Wetiko hits Wetiko and Wetiko hits Wetiko in return. I am very forthright as you can see in exposing Wetikos of the Cult, but I don't hate them. I refuse to hate them. It's what they want. What you hate you become. What you *fight* you become. Wokers, 'anti-haters' and 'anti-fascists' prove this every time they reach for their keyboards or don their balaclavas. By walk away I mean to disengage from Wetiko which includes ceasing to cooperate with its tyranny. Paul Levy says of Wetiko:

The way to 'defeat' evil is not to try to destroy it (for then, in playing evil's game, we have already lost), but rather, to find the invulnerable place within ourselves where evil is unable to vanquish us – this is to truly 'win' our battle with evil.

Wetiko is everywhere in human society and it's been on steroids since the 'Covid' hoax. Every shouting match over wearing masks has Wetiko wearing a mask and Wetiko not wearing one. It's an electrical circuit of push and resist, push and resist, with Wetiko pushing *and* resisting. Each polarity is Wetiko empowering itself. Dictionary definitions of 'resist' include 'opposing, refusing to accept or comply with' and the word to focus on is 'opposing'. What form does this take – setting police cars alight or 'refusing to accept or comply with'? The former is Wetiko opposing Wetiko while the other points the way forward. This is the difference between those aggressively demanding that government fascism must be obeyed who stand in stark contrast to the great majority of Pushbackers. We saw this clearly with a march by thousands of Pushbackers against lockdown in London followed days later by a Woker-hijacked

protest in Bristol in which police cars were set on fire. Masks were virtually absent in London and widespread in Bristol. Wetiko wants lockdown on every level of society and infuses its aggression to police it through its unknowing stooges. Lockdown protesters are the ones with the smiling faces and the hugs, The two blatantly obvious states of being – getting more obvious by the day – are the result of Wokers and their like becoming ever more influenced by the simulation Field of Wetiko and Pushbackers ever more influenced by The Field of a far higher vibration beyond the simulation. Wetiko can't invade the heart which is where most lockdown opponents are coming from. It's the heart that allows them to see through the lies to the truth in ways I will be highlighting.

Renegade Minds know that calmness is the place from which wisdom comes. You won't find wisdom in a hissing fit and wisdom is what we need in abundance right now. Calmness is not weakness – you don't have to scream at the top of your voice to be strong. Calmness is indeed a sign of strength. 'No' means I'm not doing it. NOOOO!!! doesn't mean you're not doing it even more. Volume does not advance 'No – I'm not doing it'. You are just not doing it. Wetiko possessed and influenced don't know how to deal with that. Wetiko wants a fight and we should not give it one. What it needs more than anything is our *cooperation* and we should not give that either. Mass rallies and marches are great in that they are a visual representation of feeling, but if it ends there they are irrelevant. You demand that Wetikos act differently? Well, they're not going to are they? They are Wetikos. We don't need to waste our time demanding that something doesn't happen when that will make no difference. We need to delete the means that *allows* it to happen. This, invariably, is our cooperation. You can demand a child stop firing a peashooter at the dog or you can refuse to buy the peashooter. If you provide the means you are cooperating with the dog being smacked on the nose with a pea. How can the authorities enforce mask-wearing if millions in a country refuse? What if the 74 million Pushbackers that voted for Trump in 2020 refused to wear masks, close their businesses or stay in their homes. It would be unenforceable. The

few control the many through the compliance of the many and that's always been the dynamic be it 'Covid' regulations or the Roman Empire. I know people can find it intimidating to say no to authority or stand out in a crowd for being the only one with a face on display; but it has to be done or it's over. I hope I've made clear in this book that where this is going will be far more intimidating than standing up now and saying 'No' – I will not cooperate with my own enslavement and that of my children. There might be consequences for some initially, although not so if enough do the same. The question that must be addressed is what is going to happen if we don't? It is time to be strong and unyieldingly so. No means no. Not here and there, but *everywhere* and *always*. I have refused to wear a mask and obey all the other nonsense. I will not comply with tyranny. I repeat: Fascism is not imposed by fascists – there are never enough of them. Fascism is imposed by the population acquiescing to fascism. *I will not do it*. I will die first, or my body will. Living meekly under fascism is a form of death anyway, the death of the spirit that Martin Luther King described.

## **Making things happen**

We must not despair. This is not over till it's over and it's far from that. The 'fat lady' must refuse to sing. The longer the 'Covid' hoax has dragged on and impacted on more lives we have seen an awakening of phenomenal numbers of people worldwide to the realisation that what they have believed all their lives is not how the world really is. Research published by the system-serving University of Bristol and King's College London in February, 2021, concluded: 'One in every 11 people in Britain say they trust David Icke's take on the coronavirus pandemic.' It will be more by now and we have gathering numbers to build on. We must urgently progress from seeing the scam to ceasing to cooperate with it. Prominent German lawyer Reiner Fuellmich, also licenced to practice law in America, is doing a magnificent job taking the legal route to bring the psychopaths to justice through a second Nuremberg tribunal for crimes against humanity. Fuellmich has an impressive record of

beating the elite in court and he formed the German Corona Investigative Committee to pursue civil charges against the main perpetrators with a view to triggering criminal charges. Most importantly he has grasped the foundation of the hoax – the PCR test not testing for the ‘virus’ – and Christian Drosten is therefore on his charge sheet along with Gates frontman Tedros at the World Health Organization. Major players must not be allowed to inflict their horrors on the human race without being brought to book. A life sentence must follow for Bill Gates and the rest of them. A group of researchers has also indicted the government of Norway for crimes against humanity with copies sent to the police and the International Criminal Court. The lawsuit cites participation in an internationally-planned false pandemic and violation of international law and human rights, the European Commission’s definition of human rights by coercive rules, Nuremberg and Hague rules on fundamental human rights, and the Norwegian constitution. We must take the initiative from hereon and not just complain, protest and react.

There are practical ways to support vital mass non-cooperation. Organising in numbers is one. Lockdown marches in London in the spring in 2021 were mass non-cooperation that the authorities could not stop. There were too many people. Hundreds of thousands walked the London streets in the centre of the road for mile after mile while the Face-Nappies could only look on. They were determined, but calm, and just *did it* with no histrionics and lots of smiles. The police were impotent. Others are organising group shopping without masks for mutual support and imagine if that was happening all over. Policing it would be impossible. If the store refuses to serve people in these circumstances they would be faced with a long line of trolleys full of goods standing on their own and everything would have to be returned to the shelves. How would they cope with that if it kept happening? I am talking here about moving on from complaining to being pro-active; from watching things happen to making things happen. I include in this our relationship with the police. The behaviour of many Face-Nappies



has been disgraceful and anyone who thinks they would never find concentration camp guards in the 'enlightened' modern era have had that myth busted big-time. The period and setting may change – Wetikos never do. I watched film footage from a London march in which a police thug viciously kicked a protestor on the floor who had done nothing. His fellow Face-Nappies stood in a ring protecting him. What he did was a criminal assault and with a crowd far outnumbering the police this can no longer be allowed to happen unchallenged. I get it when people chant 'shame on you' in these circumstances, but that is no longer enough. They *have* no shame those who do this. Crowds needs to start making a citizen's arrest of the police who commit criminal offences and brutally attack innocent people and defenceless women. A citizen's arrest can be made under section 24A of the UK Police and Criminal Evidence (PACE) Act of 1984 and you will find something similar in other countries. I prefer to call it a Common Law arrest rather than citizen's for reasons I will come to shortly. Anyone can arrest a person committing an indictable offence or if they have reasonable grounds to suspect they are committing an indictable offence. On both counts the attack by the police thug would have fallen into this category. A citizen's arrest can be made to stop someone:

- Causing physical injury to himself or any other person
- Suffering physical injury
- Causing loss of or damage to property
- Making off before a constable can assume responsibility for him

A citizen's arrest may also be made to prevent a breach of the peace under Common Law and if they believe a breach of the peace will happen or anything related to harm likely to be done or already done in their presence. This is the way to go I think – the Common Law version. If police know that the crowd and members of the public will no longer be standing and watching while they commit

their thuggery and crimes they will think twice about acting like Brownshirts and Blackshirts.

## **Common Law – common sense**

Mention of Common Law is very important. Most people think the law is the law as in one law. This is not the case. There are two bodies of law, Common Law and Statute Law, and they are not the same. Common Law is founded on the simple premise of do no harm. It does not recognise victimless crimes in which no harm is done while Statute Law does. There is a Statute Law against almost everything. So what is Statute Law? Amazingly it's the law of the *sea* that was brought ashore by the Cult to override the law of the land which is Common Law. They had no right to do this and as always they did it anyway. They had to. They could not impose their will on the people through Common Law which only applies to do no harm. How could you stitch up the fine detail of people's lives with that? Instead they took the law of the sea, or Admiralty Law, and applied it to the population. Statute Law refers to all the laws spewing out of governments and their agencies including all the fascist laws and regulations relating to 'Covid'. The key point to make is that Statute Law is *contract law*. It only applies between *contracting* corporations. Most police officers don't even know this. They have to be kept in the dark, too. Long ago when merchants and their sailing ships began to trade with different countries a contractual law was developed called Admiralty Law and other names. Again it only applied to *contracts* agreed between *corporate* entities. If there is no agreed contract the law of the sea had no jurisdiction *and that still applies to its new alias of Statute Law*. The problem for the Cult when the law of the sea was brought ashore was an obvious one. People were not corporations and neither were government entities. To overcome the latter they made governments and all associated organisations corporations. All the institutions are *private corporations* and I mean governments and their agencies, local councils, police, courts, military, US states, the whole lot. Go to the

Dun and Bradstreet corporate listings website for confirmation that they are all corporations. You are arrested by a private corporation called the police by someone who is really a private security guard and they take you to court which is another private corporation. Neither have jurisdiction over you unless you consent and *contract* with them. This is why you hear the mantra about law enforcement policing by *consent* of the people. In truth the people 'consent' only in theory through monumental trickery.

Okay, the Cult overcame the corporate law problem by making governments and institutions corporate entities; but what about people? They are not corporations are they? Ah ... well in a sense, and *only* a sense, they are. Not people exactly – the illusion of people. The Cult creates a corporation in the name of everyone at the time that their birth certificate is issued. Note birth/ *berth* certificate and when you go to court under the law of the sea on land you stand in a *dock*. These are throwbacks to the origin. My Common Law name is David Vaughan Icke. The name of the corporation created by the government when I was born is called Mr David Vaughan Icke usually written in capitals as MR DAVID VAUGHAN ICKE. That is not me, the living, breathing man. It is a fictitious corporate entity. The trick is to make you think that David Vaughan Icke and MR DAVID VAUGHAN ICKE are the same thing. *They are not*. When police charge you and take you to court they are prosecuting the corporate entity and not the living, breathing, man or woman. They have to trick you into identifying as the corporate entity and contracting with them. Otherwise they have no jurisdiction. They do this through a language known as legalese. Lawful and legal are not the same either. Lawful relates to Common Law and legal relates to Statute Law. Legalese is the language of Statue Law which uses terms that mean one thing to the public and another in legalese. Notice that when a police officer tells someone why they are being charged he or she will say at the end: 'Do you understand?' To the public that means 'Do you comprehend?' In legalese it means 'Do you stand under me?' Do you stand under my authority? If you say

yes to the question you are unknowingly agreeing to give them jurisdiction over you in a contract between two corporate entities.

This is a confidence trick in every way. Contracts have to be agreed between informed parties and if you don't know that David Vaughan Icke is agreeing to be the corporation MR DAVID VAUGHAN ICKE you cannot knowingly agree to contract. They are deceiving you and another way they do this is to ask for proof of identity. You usually show them a driving licence or other document on which your corporate name is written. In doing so you are accepting that you are that corporate entity when you are not. Referring to yourself as a 'person' or 'citizen' is also identifying with your corporate fiction which is why I made the Common Law point about the citizen's arrest. If you are approached by a police officer you identify yourself immediately as a living, breathing, man or woman and say 'I do not consent, I do not contract with you and I do not understand' or stand under their authority. I have a Common Law birth certificate as a living man and these are available at no charge from [commonlawcourt.com](http://commonlawcourt.com). Businesses registered under the Statute Law system means that its laws apply. There are, however, ways to run a business under Common Law. Remember all 'Covid' laws and regulations are Statute Law – the law of *contracts* and you do not have to contract. This doesn't mean that you can kill someone and get away with it. Common Law says do no harm and that applies to physical harm, financial harm etc. Police are employees of private corporations and there needs to be a new system of non-corporate Common Law constables operating outside the Statute Law system. If you go to [davidicke.com](http://davidicke.com) and put Common Law into the search engine you will find videos that explain Common Law in much greater detail. It is definitely a road we should walk.

### **With all my heart**

I have heard people say that we are in a spiritual war. I don't like the term 'war' with its Wetiko dynamic, but I know what they mean. Sweep aside all the bodily forms and we are in a situation in which two states of consciousness are seeking very different realities.

Wetiko wants upheaval, chaos, fear, suffering, conflict and control. The other wants love, peace, harmony, fairness and freedom. That's where we are. We should not fall for the idea that Wetiko is all-powerful and there's nothing we can do. Wetiko is not all-powerful. It's a joke, pathetic. It doesn't have to be, but it has made that choice for now. A handful of times over the years when I have felt the presence of its frequency I have allowed it to attach briefly so I could consciously observe its nature. The experience is not pleasant, the energy is heavy and dark, but the ease with which you can kick it back out the door shows that its real power is in persuading us that it has power. It's all a con. Wetiko is a con. It's a trickster and not a power that can control us if we unleash our own. The con is founded on manipulating humanity to give its power to Wetiko which recycles it back to present the illusion that it has power when its power is *ours* that we gave away. This happens on an energetic level and plays out in the world of the seen as humanity giving its power to Wetiko authority which uses that power to control the population when the power is only the power the population has handed over. How could it be any other way for billions to be controlled by a relative few? I have had experiences with people possessed by Wetiko and again you can kick its arse if you do it with an open heart. Oh yes – the *heart* which can transform the world of perceived 'matter'.

We are receiver-transmitters and processors of information, but what information and where from? Information is processed into perception in three main areas – the brain, the heart and the belly. These relate to thinking, knowing, and emotion. Wetiko wants us to be head and belly people which means we think within the confines of the Matrix simulation and low-vibrational emotional reaction scrambles balance and perception. A few minutes on social media and you see how emotion is the dominant force. Woke is all emotion and is therefore thought-free and fact-free. Our heart is something different. It *knows* while the head *thinks* and has to try to work it out because it doesn't know. The human energy field has seven prime vortexes which connect us with wider reality ([Fig 23](#)). Chakra means

'wheels of light' in the Sanskrit language of ancient India. The main ones are: The crown chakra on top of the head; brow (or 'third eye') chakra in the centre of the forehead; throat chakra; heart chakra in the centre of the chest; solar plexus chakra below the sternum; sacral chakra beneath the navel; and base chakra at the bottom of the spine. Each one has a particular function or functions. We feel anxiety and nervousness in the belly where the sacral chakra is located and this processes emotion that can affect the colon to give people 'the shits' or make them 'shit scared' when they are nervous. Chakras all play an important role, but the Mr and Mrs Big is the heart chakra which sits at the centre of the seven, above the chakras that connect us to the 'physical' and below those that connect with higher realms (or at least should). Here in the heart chakra we feel love, empathy and compassion – 'My heart goes out to you'. Those with closed hearts become literally 'heart-less' in their attitudes and behaviour (see Bill Gates). Native Americans portrayed Wetiko with what Paul Levy calls a 'frigid, icy heart, devoid of mercy' (see Bill Gates).



**Figure 23:** The chakra system which interpenetrates the human energy field. The heart chakra is the governor – or should be.

Wetiko trembles at the thought of heart energy which it cannot infiltrate. The frequency is too high. What it seeks to do instead is close the heart chakra vortex to block its perceptual and energetic influence. Psychopaths have 'hearts of stone' and emotionally-damaged people have 'heartache' and 'broken hearts'. The astonishing amount of heart disease is related to heart chakra

disruption with its fundamental connection to the 'physical' heart. Dr Tom Cowan has written an outstanding book challenging the belief that the heart is a pump and making the connection between the 'physical' and spiritual heart. Rudolph Steiner who was way ahead of his time said the same about the fallacy that the heart is a pump. *What?* The heart is not a pump? That's crazy, right? Everybody knows that. Read Cowan's *Human Heart, Cosmic Heart* and you will realise that the very idea of the heart as a pump is ridiculous when you see the evidence. How does blood in the feet so far from the heart get pumped horizontally up the body by the heart?? Cowan explains in the book the real reason why blood moves as it does. Our 'physical' heart is used to symbolise love when the source is really the heart vortex or spiritual heart which is our most powerful energetic connection to 'out there' expanded consciousness. That's why we feel *knowing* – intuitive knowing – in the centre of the chest. Knowing doesn't come from a process of thoughts leading to a conclusion. It is there in an instant all in one go. Our heart knows because of its connection to levels of awareness that *do* know. This is the meaning and source of intuition – intuitive *knowing*.

For the last more than 30 years of uncovering the global game and the nature of reality my heart has been my constant antenna for truth and accuracy. An American intelligence insider once said that I had quoted a disinformant in one of my books and yet I had only quoted the part that was true. He asked: 'How do you do that?' By using my heart antenna was the answer and anyone can do it. Heart-centred is how we are meant to be. With a closed heart chakra we withdraw into a closed mind and the bubble of five-sense reality. If you take a moment to focus your attention on the centre of your chest, picture a spinning wheel of light and see it opening and expanding. You will feel it happening, too, and perceptions of the heart like joy and love as the heart impacts on the mind as they interact. The more the chakra opens the more you will feel expressions of heart consciousness and as the process continues, and becomes part of you, insights and knowings will follow. An open

heart is connected to that level of awareness that knows all is *One*. You will see from its perspective that the fault-lines that divide us are only illusions to control us. An open heart does not process the illusions of race, creed and sexuality except as brief experiences for a consciousness that is all. Our heart does not see division, only unity (Figs 24 and 25). There's something else, too. Our hearts love to laugh. Mark Twain's quote that says 'The human race has one really effective weapon, and that is laughter' is really a reference to the heart which loves to laugh with the joy of knowing the true nature of infinite reality and that all the madness of human society is an illusion of the mind. Twain also said: 'Against the assault of laughter nothing can stand.' This is so true of Wetiko and the Cult. Their insecurity demands that they be taken seriously and their power and authority acknowledged and feared. We should do nothing of the sort. We should not get aggressive or fearful which their insecurity so desires. We should laugh in their face. Even in their no-face as police come over in their face-nappies and expect to be taken seriously. They don't take themselves seriously looking like that so why should we? Laugh in the face of intimidation. Laugh in the face of tyranny. You will see by its reaction that you have pressed all of its buttons. Wetiko does not know what to do in the face of laughter or when its targets refuse to concede their joy to fear. We have seen many examples during the 'Covid' hoax when people have expressed their energetic power and the string puppets of Wetiko retreat with their tail limp between their knees. Laugh – the world is bloody mad after all and if it's a choice between laughter and tears I know which way I'm going.





**Figure 24:** Head consciousness without the heart sees division and everything apart from everything else.



**Figure 25:** Heart consciousness sees everything as One.

## **'Vaccines' and the soul**

The foundation of Wetiko/Archon control of humans is the separation of incarnate five-sense mind from the infinite 'I' and closing the heart chakra where the True 'I' lives during a human life. The goal has been to achieve complete separation in both cases. I was interested therefore to read an account by a French energetic healer of what she said she experienced with a patient who had been given the 'Covid' vaccine. Genuine energy healers can sense information and consciousness fields at different levels of being which are referred to as 'subtle bodies'. She described treating the patient who later returned after having, without the healer's knowledge, two doses of the 'Covid vaccine'. The healer said:

I noticed immediately the change, very heavy energy emanating from [the] subtle bodies. The scariest thing was when I was working on the heart chakra, I connected with her soul: it was detached from the physical body, it had no contact and it was, as if it was floating in a state of total confusion: a damage to the consciousness that loses contact with the physical body, i.e. with our biological machine, there is no longer any communication between them.

I continued the treatment by sending light to the heart chakra, the soul of the person, but it seemed that the soul could no longer receive any light, frequency or energy. It was a very powerful experience for me. Then I understood that this substance is indeed used to detach consciousness so that this consciousness can no longer interact through this body that it possesses in life, where there is no longer any contact, no frequency, no light, no more energetic balance or mind.

This would create a human that is rudderless and at the extreme almost zombie-like operating with a fractional state of consciousness at the mercy of Wetiko. I was especially intrigued by what the healer said in the light of the prediction by the highly-informed Rudolf Steiner more than a hundred years ago. He said:

In the future, we will eliminate the soul with medicine. Under the pretext of a 'healthy point of view', there will be a vaccine by which the human body will be treated as soon as possible directly at birth, so that the human being cannot develop the thought of the existence of soul and Spirit. To materialistic doctors will be entrusted the task of removing the soul of humanity.

As today, people are vaccinated against this disease or that disease, so in the future, children will be vaccinated with a substance that can be produced precisely in such a way that people, thanks to this vaccination, will be immune to being subjected to the 'madness' of spiritual life. He would be extremely smart, but he would not develop a conscience, and that is the true goal of some materialistic circles.

Steiner said the vaccine would detach the physical body from the etheric body (subtle bodies) and 'once the etheric body is detached the relationship between the universe and the etheric body would become extremely unstable, and man would become an automaton'. He said 'the physical body of man must be polished on this Earth by spiritual will – so the vaccine becomes a kind of arymanique (Wetiko) force' and 'man can no longer get rid of a given materialistic feeling'. Humans would then, he said, become 'materialistic of constitution and can no longer rise to the spiritual'. I have been writing for years about DNA being a receiver-transmitter of information that connects us to other levels of reality and these 'vaccines' changing DNA can be likened to changing an antenna and what it can transmit and receive. Such a disconnection would clearly lead to changes in personality and perception. Steiner further predicted the arrival of AI. Big Pharma 'Covid vaccine' makers, expressions of Wetiko, are testing their DNA-manipulating evil on children as I write with a view to giving the 'vaccine' to babies. If it's a soul-body disconnecter – and I say that it is or can be – every child would be disconnected from 'soul' at birth and the 'vaccine' would create a closed system in which spiritual guidance from the greater self would play no part. This has been the ambition of Wetiko all

along. A Pentagon video from 2005 was leaked of a presentation explaining the development of vaccines to change behaviour by their effect on the brain. Those that believe this is not happening with the 'Covid' genetically-modifying procedure masquerading as a 'vaccine' should make an urgent appointment with Naivety Anonymous. Klaus Schwab wrote in 2018:

Neurotechnologies enable us to better influence consciousness and thought and to understand many activities of the brain. They include decoding what we are thinking in fine levels of detail through new chemicals and interventions that can influence our brains to correct for errors or enhance functionality.

The plan is clear and only the heart can stop it. With every heart that opens, every mind that awakens, Wetiko is weakened. Heart and love are far more powerful than head and hate and so nothing like a majority is needed to turn this around.

## **Beyond the Phantom**

Our heart is the prime target of Wetiko and so it must be the answer to Wetiko. We *are* our heart which is part of one heart, the infinite heart. Our heart is where the true self lives in a human life behind firewalls of five-sense illusion when an imposter takes its place – *Phantom Self*; but our heart waits patiently to be set free any time we choose to see beyond the Phantom, beyond Wetiko. A Wetikoed Phantom Self can wreak mass death and destruction while the love of forever is locked away in its heart. The time is here to unleash its power and let it sweep away the fear and despair that is Wetiko. Heart consciousness does not seek manipulated, censored, advantage for its belief or religion, its activism and desires. As an expression of the One it treats all as One with the same rights to freedom and opinion. Our heart demands fairness for itself no more than for others. From this unity of heart we can come together in mutual support and transform this Wetikoed world into what reality is meant to be – a place of love, joy, happiness, fairness, justice and freedom. Wetiko has another agenda and that's why the world is as

it is, but enough of this nonsense. Wetiko can't stay where hearts are open and it works so hard to keep them closed. Fear is its currency and its food source and love in its true sense has no fear. Why would love have fear when it knows it is *All That Is, Has Been, And Ever Can Be* on an eternal exploration of all possibility? Love in this true sense is not the physical attraction that passes for love. This can be an expression of it, yes, but Infinite Love, a love without condition, goes far deeper to the core of all being. It *is* the core of all being. Infinite reality was born from love beyond the illusions of the simulation. Love infinitely expressed is the knowing that all is One and the swiftly-passing experience of separation is a temporary hallucination. You cannot disconnect from Oneness; you can only *perceive* that you have and withdraw from its influence. This is the most important of all perception trickery by the mind parasite that is Wetiko and the foundation of all its potential for manipulation.

If we open our hearts, open the sluice gates of the mind, and redefine self-identity amazing things start to happen. Consciousness expands or contracts in accordance with self-identity. When true self is recognised as infinite awareness and label self – Phantom Self – is seen as only a series of brief experiences life is transformed. Consciousness expands to the extent that self-identity expands and everything changes. You see unity, not division, the picture, not the pixels. From this we can play the long game. No more is an experience something in and of itself, but a fleeting moment in the eternity of forever. Suddenly people in uniform and dark suits are no longer intimidating. Doing what your heart knows to be right is no longer intimidating and consequences for those actions take on the same nature of a brief experience that passes in the blink of an infinite eye. Intimidation is all in the mind. Beyond the mind there is no intimidation.

An open heart does not consider consequences for what it knows to be right. To do so would be to consider not doing what it knows to be right and for a heart in its power that is never an option. The Renegade Mind is really the Renegade Heart. Consideration of consequences will always provide a getaway car for the mind and

the heart doesn't want one. What is right in the light of what we face today is to stop cooperating with Wetiko in all its forms and to do it without fear or compromise. You cannot compromise with tyranny when tyranny always demands more until it has everything. Life is your perception and you are your destiny. Change your perception and you change your life. Change collective perception and we change the world.

*Come on people ... One human family, One heart, One goal ...*  
**FREEEEEEEDOM!**

We must settle for nothing less.

## Postscript

The big scare story as the book goes to press is the 'Indian' variant and the world is being deluged with propaganda about the 'Covid catastrophe' in India which mirrors in its lies and misrepresentations what happened in Italy before the first lockdown in 2020.

The *New York Post* published a picture of someone who had 'collapsed in the street from Covid' in India in April, 2021, which was actually taken during a gas leak in May, 2020. Same old, same old. Media articles in mid-February were asking why India had been so untouched by 'Covid' and then as their vaccine rollout gathered pace the alleged 'cases' began to rapidly increase. Indian 'Covid vaccine' maker Bharat Biotech was funded into existence by the Bill and Melinda Gates Foundation (the pair announced their divorce in May, 2021, which is a pity because they so deserve each other). The Indian 'Covid crisis' was ramped up by the media to terrify the world and prepare people for submission to still more restrictions. The scam that worked the first time was being repeated only with far more people seeing through the deceit. [Davidicke.com](http://Davidicke.com) and [Ickonic.com](http://Ickonic.com) have sought to tell the true story of what is happening by talking to people living through the Indian nightmare which has nothing to do with 'Covid'. We posted a letter from 'Alisha' in Pune who told a very different story to government and media mendacity. She said scenes of dying people and overwhelmed hospitals were designed to hide what was really happening – genocide and starvation. Alisha said that millions had already died of starvation during the ongoing lockdowns while government and media were lying and making it look like the 'virus':

Restaurants, shops, gyms, theatres, basically everything is shut. The cities are ghost towns. Even so-called 'essential' businesses are only open till 11am in the morning. You basically have just an hour to buy food and then your time is up.

Inter-state travel and even inter-district travel is banned. The cops wait at all major crossroads to question why you are traveling outdoors or to fine you if you are not wearing a mask.

The medical community here is also complicit in genocide, lying about hospitals being full and turning away people with genuine illnesses, who need immediate care. They have even created a shortage of oxygen cylinders.

This is the classic Cult modus operandi played out in every country. Alisha said that people who would not have a PCR test not testing for the 'virus' were being denied hospital treatment. She said the people hit hardest were migrant workers and those in rural areas. Most businesses employed migrant workers and with everything closed there were no jobs, no income and no food. As a result millions were dying of starvation or malnutrition. All this was happening under Prime Minister Narendra Modi, a 100-percent asset of the Cult, and it emphasises yet again the scale of pure anti-human evil we are dealing with. Australia banned its people from returning home from India with penalties for trying to do so of up to five years in jail and a fine of £37,000. The manufactured 'Covid' crisis in India was being prepared to justify further fascism in the West. Obvious connections could be seen between the Indian 'vaccine' programme and increased 'cases' and this became a common theme. The Seychelles, the most per capita 'Covid vaccinated' population in the world, went back into lockdown after a 'surge of cases'.

Long ago the truly evil Monsanto agricultural biotechnology corporation with its big connections to Bill Gates devastated Indian farming with genetically-modified crops. Human rights activist Gurcharan Singh highlighted the efforts by the Indian government to complete the job by destroying the food supply to hundreds of millions with 'Covid' lockdowns. He said that 415 million people at the bottom of the disgusting caste system (still going whatever they say) were below the poverty line and struggled to feed themselves every year. Now the government was imposing lockdown at just the

time to destroy the harvest. This deliberate policy was leading to mass starvation. People may reel back at the suggestion that a government would do that, but Wetiko-controlled 'leaders' are capable of any level of evil. In fact what is described in India is in the process of being instigated worldwide. The food chain and food supply are being targeted at every level to cause world hunger and thus control. Bill Gates is not the biggest owner of farmland in America for no reason and destroying access to food aids both the depopulation agenda and the plan for synthetic 'food' already being funded into existence by Gates. Add to this the coming hyper-inflation from the suicidal creation of fake 'money' in response to 'Covid' and the breakdown of container shipping systems and you have a cocktail that can only lead one way and is meant to. The Cult plan is to crash the entire system to 'build back better' with the Great Reset.

### **'Vaccine' transmission**

Reports from all over the world continue to emerge of women suffering menstrual and fertility problems after having the fake 'vaccine' and of the non-'vaccinated' having similar problems when interacting with the 'vaccinated'. There are far too many for 'coincidence' to be credible. We've had menopausal women getting periods, others having periods stop or not stopping for weeks, passing clots, sometimes the lining of the uterus, breast irregularities, and miscarriages (which increased by 400 percent in parts of the United States). Non-'vaccinated' men and children have suffered blood clots and nose bleeding after interaction with the 'vaccinated'. Babies have died from the effects of breast milk from a 'vaccinated' mother. Awake doctors – the small minority – speculated on the cause of non-'vaccinated' suffering the same effects as the 'vaccinated'. Was it nanotechnology in the synthetic substance transmitting frequencies or was it a straight chemical bioweapon that was being transmitted between people? I am not saying that some kind of chemical transmission is not one possible answer, but the foundation of all that the Cult does is frequency and



this is fertile ground for understanding how transmission can happen. American doctor Carrie Madej, an internal medicine physician and osteopath, has been practicing for the last 20 years, teaching medical students, and she says attending different meetings where the agenda for humanity was discussed. Madej, who operates out of Georgia, did not dismiss other possible forms of transmission, but she focused on frequency in search of an explanation for transmission. She said the Moderna and Pfizer 'vaccines' contained nano-lipid particles as a key component. This was a brand new technology never before used on humanity. 'They're using a nanotechnology which is pretty much little tiny computer bits ... nanobots or hydrogel.' Inside the 'vaccines' was 'this sci-fi kind of substance' which suppressed immune checkpoints to get into the cell. I referred to this earlier as the 'Trojan horse' technique that tricks the cell into opening a gateway for the self-replicating synthetic material and while the immune system is artificially suppressed the body has no defences. Madej said the substance served many purposes including an on-demand ability to 'deliver the payload' and using the nano 'computer bits' as biosensors in the body. 'It actually has the ability to accumulate data from your body, like your breathing, your respiration, thoughts, emotions, all kinds of things.'

She said the technology obviously has the ability to operate through Wi-Fi and transmit and receive energy, messages, frequencies or impulses. 'Just imagine you're getting this new substance in you and it can react to things all around you, the 5G, your smart device, your phones.' We had something completely foreign in the human body that had never been launched large scale at a time when we were seeing 5G going into schools and hospitals (plus the Musk satellites) and she believed the 'vaccine' transmission had something to do with this: '... if these people have this inside of them ... it can act like an antenna and actually transmit it outwardly as well.' The synthetic substance produced its own voltage and so it could have that kind of effect. This fits with my own contention that the nano receiver-transmitters are designed to connect people to the

Smart Grid and break the receiver-transmitter connection to expanded consciousness. That would explain the French energy healer's experience of the disconnection of body from 'soul' with those who have had the 'vaccine'. The nanobots, self-replicating inside the body, would also transmit the synthetic frequency which could be picked up through close interaction by those who have not been 'vaccinated'. Madej speculated that perhaps it was 5G and increased levels of other radiation that was causing the symptoms directly although interestingly she said that non-'vaccinated' patients had shown improvement when they were away from the 'vaccinated' person they had interacted with. It must be remembered that you can control frequency and energy with your mind and you can consciously create energetic barriers or bubbles with the mind to stop damaging frequencies from penetrating your field. American paediatrician Dr Larry Palevsky said the 'vaccine' was not a 'vaccine' and was never designed to protect from a 'viral' infection. He called it 'a massive, brilliant propaganda of genocide' because they didn't have to inject everyone to get the result they wanted. He said the content of the jabs was able to infuse any material into the brain, heart, lungs, kidneys, liver, sperm and female productive system. 'This is genocide; this is a weapon of mass destruction.' At the same time American colleges were banning students from attending if they didn't have this life-changing and potentially life-ending 'vaccine'. Class action lawsuits must follow when the consequences of this college fascism come to light. As the book was going to press came reports about fertility effects on sperm in 'vaccinated' men which would absolutely fit with what I have been saying and hospitals continued to fill with 'vaccine' reactions. Another question is what about transmission via blood transfusions? The NHS has extended blood donation restrictions from seven days after a 'Covid vaccination' to 28 days after even a sore arm reaction.

I said in the spring of 2020 that the then touted 'Covid vaccine' would be ongoing each year like the flu jab. A year later Pfizer CEO, the appalling Albert Bourla, said people would 'likely' need a 'booster dose' of the 'vaccine' within 12 months of getting 'fully

vaccinated' and then a yearly shot. 'Variants will play a key role', he said confirming the point. Johnson & Johnson CEO Alex Gorsky also took time out from his 'vaccine' disaster to say that people may need to be vaccinated against 'Covid-19' each year. UK Health Secretary, the psychopath Matt Hancock, said additional 'boosters' would be available in the autumn of 2021. This is the trap of the 'vaccine passport'. The public will have to accept every last 'vaccine' they introduce, including for the fake 'variants', or it would cease to be valid. The only other way in some cases would be continuous testing with a test not testing for the 'virus' and what is on the swabs constantly pushed up your nose towards the brain every time?

### **'Vaccines' changing behaviour**

I mentioned in the body of the book how I believed we would see gathering behaviour changes in the 'vaccinated' and I am already hearing such comments from the non-'vaccinated' describing behaviour changes in friends, loved ones and work colleagues. This will only increase as the self-replicating synthetic material and nanoparticles expand in body and brain. An article in the *Guardian* in 2016 detailed research at the University of Virginia in Charlottesville which developed a new method for controlling brain circuits associated with complex animal behaviour. The method, dubbed 'magnetogenetics', involves genetically-engineering a protein called ferritin, which stores and releases iron, to create a magnetised substance – 'Magneto' – that can activate specific groups of nerve cells from a distance. This is claimed to be an advance on other methods of brain activity manipulation known as optogenetics and chemogenetics (the Cult has been developing methods of brain control for a long time). The ferritin technique is said to be non-invasive and able to activate neurons 'rapidly and reversibly'. In other words, human thought and perception. The article said that earlier studies revealed how nerve cell proteins 'activated by heat and mechanical pressure can be genetically engineered so that they become sensitive to radio waves and magnetic fields, by attaching them to an iron-storing protein called ferritin, or to inorganic

paramagnetic particles'. Sensitive to radio waves and magnetic fields? You mean like 5G, 6G and 7G? This is the human-AI Smart Grid hive mind we are talking about. The *Guardian* article said:

... the researchers injected Magneto into the striatum of freely behaving mice, a deep brain structure containing dopamine-producing neurons that are involved in reward and motivation, and then placed the animals into an apparatus split into magnetised and non-magnetised sections.

Mice expressing Magneto spent far more time in the magnetised areas than mice that did not, because activation of the protein caused the striatal neurons expressing it to release dopamine, so that the mice found being in those areas rewarding. This shows that Magneto can remotely control the firing of neurons deep within the brain, and also control complex behaviours.

Make no mistake this basic methodology will be part of the 'Covid vaccine' cocktail and using magnetics to change brain function through electromagnetic field frequency activation. The Pentagon is developing a 'Covid vaccine' using ferritin. Magnetics would explain changes in behaviour and why videos are appearing across the Internet as I write showing how magnets stick to the skin at the point of the 'vaccine' shot. Once people take these 'vaccines' anything becomes possible in terms of brain function and illness which will be blamed on 'Covid-19' and 'variants'. Magnetic field manipulation would further explain why the non-'vaccinated' are reporting the same symptoms as the 'vaccinated' they interact with and why those symptoms are reported to decrease when not in their company. Interestingly 'Magneto', a 'mutant', is a character in the Marvel Comic *X-Men* stories with the ability to manipulate magnetic fields and he believes that mutants should fight back against their human oppressors by any means necessary. The character was born Erik Lehnsherr to a Jewish family in Germany.

## **Cult-controlled courts**

The European Court of Human Rights opened the door for mandatory 'Covid-19 vaccines' across the continent when it ruled in a Czech Republic dispute over childhood immunisation that legally

enforced vaccination could be 'necessary in a democratic society'. The 17 judges decided that compulsory vaccinations did not breach human rights law. On the face of it the judgement was so inverted you gasp for air. If not having a vaccine infused into your body is not a human right then what is? Ah, but they said human rights law which has been specifically written to delete all human rights at the behest of the state (the Cult). Article 8 of the European Convention on Human Rights relates to the right to a private life. The crucial word here is '*except*':

There shall be no interference by a public authority with the exercise of this right EXCEPT such as is in accordance with the law and is necessary in a democratic society in the interests of national security, public safety or the economic wellbeing of the country, for the prevention of disorder or crime, for the protection of health or morals, or for the protection of the rights and freedoms of others [My emphasis].

No interference *except* in accordance with the law means there *are* no 'human rights' *except* what EU governments decide you can have at their behest. 'As is necessary in a democratic society' explains that reference in the judgement and 'in the interests of national security, public safety or the economic well-being of the country, for the prevention of disorder or crime, for the protection of health or morals, or for the protection of the rights and freedoms of others' gives the EU a coach and horses to ride through 'human rights' and scatter them in all directions. The judiciary is not a check and balance on government extremism; it is a vehicle to enforce it. This judgement was almost laughably predictable when the last thing the Cult wanted was a decision that went against mandatory vaccination. Judges rule over and over again to benefit the system of which they are a part. Vaccination disputes that come before them are invariably delivered in favour of doctors and authorities representing the view of the state which owns the judiciary. Oh, yes, and we have even had calls to stop putting 'Covid-19' on death certificates within 28 days of a 'positive test' because it is claimed the practice makes the 'vaccine' appear not to work. They are laughing at you.

The scale of madness, inhumanity and things to come was highlighted when those not 'vaccinated' for 'Covid' were refused evacuation from the Caribbean island of St Vincent during massive volcanic eruptions. Cruise ships taking residents to the safety of another island allowed only the 'vaccinated' to board and the rest were left to their fate. Even in life and death situations like this we see 'Covid' stripping people of their most basic human instincts and the insanity is even more extreme when you think that fake 'vaccine'-makers are not even claiming their body-manipulating concoctions stop 'infection' and 'transmission' of a 'virus' that doesn't exist. St Vincent Prime Minister Ralph Gonsalves said: 'The chief medical officer will be identifying the persons already vaccinated so that we can get them on the ship.' Note again the power of the chief medical officer who, like Whitty in the UK, will be answering to the World Health Organization. This is the Cult network structure that has overridden politicians who 'follow the science' which means doing what WHO-controlled 'medical officers' and 'science advisers' tell them. Gonsalves even said that residents who were 'vaccinated' after the order so they could board the ships would still be refused entry due to possible side effects such as 'wooziness in the head'. The good news is that if they were woozy enough in the head they could qualify to be prime minister of St Vincent.

## **Microchipping freedom**

The European judgement will be used at some point to justify moves to enforce the 'Covid' DNA-manipulating procedure. Sandra Ro, CEO of the Global Blockchain Business Council, told a World Economic Forum event that she hoped 'vaccine passports' would help to 'drive forced consent and standardisation' of global digital identity schemes: 'I'm hoping with the desire and global demand for some sort of vaccine passport – so that people can get travelling and working again – [it] will drive forced consent, standardisation, and frankly, cooperation across the world.' The lady is either not very bright, or thoroughly mendacious, to use the term 'forced consent'.

You do not 'consent' if you are forced – you *submit*. She was describing what the plan has been all along and that's to enforce a digital identity on every human without which they could not function. 'Vaccine passports' are opening the door and are far from the end goal. A digital identity would allow you to be tracked in everything you do in cyberspace and this is the same technique used by Cult-owned China to enforce its social credit system of total control. The ultimate 'passport' is planned to be a microchip as my books have warned for nearly 30 years. Those nice people at the Pentagon working for the Cult-controlled Defense Advanced Research Projects Agency (DARPA) claimed in April, 2021, they have developed a microchip inserted under the skin to detect 'asymptomatic Covid-19 infection' before it becomes an outbreak and a 'revolutionary filter' that can remove the 'virus' from the blood when attached to a dialysis machine. The only problems with this are that the 'virus' does not exist and people transmitting the 'virus' with no symptoms is brain-numbing bullshit. This is, of course, not a ruse to get people to be microchipped for very different reasons. DARPA also said it was producing a one-stop 'vaccine' for the 'virus' and all 'variants'. One of the most sinister organisations on Planet Earth is doing this? Better have it then. These people are insane because Wetiko that possesses them is insane.

Researchers from the Salk Institute in California announced they have created an embryo that is part human and part monkey. My books going back to the 1990s have exposed experiments in top secret underground facilities in the United States where humans are being crossed with animal and non-human 'extraterrestrial' species. They are now easing that long-developed capability into the public arena and there is much more to come given we are dealing with psychiatric basket cases. Talking of which – Elon Musk's scientists at Neuralink trained a monkey to play Pong and other puzzles on a computer screen using a joystick and when the monkey made the correct move a metal tube squirted banana smoothie into his mouth which is the basic technique for training humans into unquestioning compliance. Two Neuralink chips were in the monkey's skull and

more than 2,000 wires 'fanned out' into its brain. Eventually the monkey played a video game purely with its brain waves. Psychopathic narcissist Musk said the 'breakthrough' was a step towards putting Neuralink chips into human skulls and merging minds with artificial intelligence. *Exactly*. This man is so dark and Cult to his DNA.

## **World Economic Fascism (WEF)**

The World Economic Forum is telling you the plan by the statements made at its many and various events. Cult-owned fascist YouTube CEO Susan Wojcicki spoke at the 2021 WEF Global Technology Governance Summit (see the name) in which 40 governments and 150 companies met to ensure 'the responsible design and deployment of emerging technologies'. Orwellian translation: 'Ensuring the design and deployment of long-planned technologies will advance the Cult agenda for control and censorship.' Freedom-destroyer and Nuremberg-bound Wojcicki expressed support for tech platforms like hers to censor content that is 'technically legal but could be harmful'. Who decides what is 'harmful'? She does and they do. 'Harmful' will be whatever the Cult doesn't want people to see and we have legislation proposed by the UK government that would censor content on the basis of 'harm' no matter if the information is fair, legal and provably true. Make that *especially* if it is fair, legal and provably true. Wojcicki called for a global coalition to be formed to enforce content moderation standards through automated censorship. This is a woman and mega-censor so self-deluded that she shamelessly accepted a 'free expression' award – *Wojcicki* – in an event sponsored by her own *YouTube*. They have no shame and no self-awareness.

You know that 'Covid' is a scam and Wojcicki a Cult operative when YouTube is censoring medical and scientific opinion purely on the grounds of whether it supports or opposes the Cult 'Covid' narrative. Florida governor Ron DeSantis compiled an expert panel with four professors of medicine from Harvard, Oxford, and Stanford Universities who spoke against forcing children and



vaccinated people to wear masks. They also said there was no proof that lockdowns reduced spread or death rates of 'Covid-19'. Cult-gofer Wojcicki and her YouTube deleted the panel video 'because it included content that contradicts the consensus of local and global health authorities regarding the efficacy of masks to prevent the spread of Covid-19'. This 'consensus' refers to what the Cult tells the World Health Organization to say and the WHO tells 'local health authorities' to do. Wojcicki knows this, of course. The panellists pointed out that censorship of scientific debate was responsible for deaths from many causes, but Wojcicki couldn't care less. She would not dare go against what she is told and as a disgrace to humanity she wouldn't want to anyway. The UK government is seeking to pass a fascist 'Online Safety Bill' to specifically target with massive fines and other means non-censored video and social media platforms to make them censor 'lawful but harmful' content like the Cult-owned Facebook, Twitter, Google and YouTube. What is 'lawful but harmful' would be decided by the fascist Blair-created Ofcom.

Another WEF obsession is a cyber-attack on the financial system and this is clearly what the Cult has planned to take down the bank accounts of everyone – except theirs. Those that think they have enough money for the Cult agenda not to matter to them have got a big lesson coming if they continue to ignore what is staring them in the face. The World Economic Forum, funded by Gates and fronted by Klaus Schwab, announced it would be running a 'simulation' with the Russian government and global banks of just such an attack called Cyber Polygon 2021. What they simulate – as with the 'Covid' Event 201 – they plan to instigate. The WEF is involved in a project with the Cult-owned Carnegie Endowment for International Peace called the WEF-Carnegie Cyber Policy Initiative which seeks to merge Wall Street banks, 'regulators' (I love it) and intelligence agencies to 'prevent' (arrange and allow) a cyber-attack that would bring down the global financial system as long planned by those that control the WEF and the Carnegie operation. The Carnegie Endowment for International Peace sent an instruction to First World

War US President Woodrow Wilson not to let the war end before society had been irreversibly transformed.

## **The Wuhan lab diversion**

As I close, the Cult-controlled authorities and lapdog media are systematically pushing 'the virus was released from the Wuhan lab' narrative. There are two versions – it happened by accident and it happened on purpose. Both are nonsense. The perceived existence of the never-shown-to-exist 'virus' is vital to sell the impression that there is actually an infective agent to deal with and to allow the endless potential for terrifying the population with 'variants' of a 'virus' that does not exist. The authorities at the time of writing are going with the 'by accident' while the alternative media is promoting the 'on purpose'. Cable news host Tucker Carlson who has questioned aspects of lockdown and 'vaccine' compulsion has bought the Wuhan lab story. 'Everyone now agrees' he said. Well, I don't and many others don't and the question is *why* does the system and its media suddenly 'agree'? When the media moves as one unit with a narrative it is always a lie – witness the hour by hour mendacity of the 'Covid' era. Why would this Cult-owned combination which has unleashed lies like machine gun fire suddenly 'agree' to tell the truth??

Much of the alternative media is buying the lie because it fits the conspiracy narrative, but it's the *wrong* conspiracy. The real conspiracy is that *there is no virus* and that is what the Cult is desperate to hide. The idea that the 'virus' was released by accident is ludicrous when the whole 'Covid' hoax was clearly long-planned and waiting to be played out as it was so fast in accordance with the Rockefeller document and Event 201. So they prepared everything in detail over decades and then sat around strumming their fingers waiting for an 'accidental' release from a bio-lab? *What??* It's crazy. Then there's the 'on purpose' claim. You want to circulate a 'deadly virus' and hide the fact that you've done so and you release it down the street from the highest-level bio-lab in China? I repeat – *What??*

You would release it far from that lab to stop any association being made. But, no, we'll do it in a place where the connection was certain to be made. Why would you need to scam 'cases' and 'deaths' and pay hospitals to diagnose 'Covid-19' if you had a real 'virus'? What are sections of the alternative media doing believing this crap? Where were all the mass deaths in Wuhan from a 'deadly pathogen' when the recovery to normal life after the initial propaganda was dramatic in speed? Why isn't the 'deadly pathogen' now circulating all over China with bodies in the street? Once again we have the technique of tell them what they want to hear and they will likely believe it. The alternative media has its 'conspiracy' and with Carlson it fits with his 'China is the danger' narrative over years. China *is* a danger as a global Cult operations centre, but not for this reason. The Wuhan lab story also has the potential to instigate conflict with China when at some stage the plan is to trigger a Problem-Reaction-Solution confrontation with the West. Question everything – *everything* – and especially when the media agrees on a common party line.

### **Third wave ... fourth wave ... fifth wave ...**

As the book went into production the world was being set up for more lockdowns and a 'third wave' supported by invented 'variants' that were increasing all the time and will continue to do so in public statements and computer programs, but not in reality. India became the new Italy in the 'Covid' propaganda campaign and we were told to be frightened of the new 'Indian strain'. Somehow I couldn't find it within myself to do so. A document produced for the UK government entitled 'Summary of further modelling of easing of restrictions – Roadmap Step 2' declared that a third wave was inevitable (of course when it's in the script) and it would be the fault of children and those who refuse the health-destroying fake 'Covid vaccine'. One of the computer models involved came from the Cult-owned *Imperial College* and the other from Warwick University which I wouldn't trust to tell me the date in a calendar factory. The document states that both models presumed extremely high uptake

of the 'Covid vaccines' and didn't allow for 'variants'. The document states: 'The resurgence is a result of some people (mostly children) being ineligible for vaccination; others choosing not to receive the vaccine; and others being vaccinated but not perfectly protected.' The mendacity takes the breath away. Okay, blame those with a brain who won't take the DNA-modifying shots and put more pressure on children to have it as 'trials' were underway involving children as young as six months with parents who give insanity a bad name. Massive pressure is being put on the young to have the fake 'vaccine' and child age consent limits have been systematically lowered around the world to stop parents intervening. Most extraordinary about the document was its claim that the 'third wave' would be driven by 'the resurgence in both hospitalisations and deaths ... dominated by *those that have received two doses of the vaccine*, comprising around 60-70% of the wave respectively'. The predicted peak of the 'third wave' suggested 300 deaths per day with 250 of them *fully 'vaccinated' people*. How many more lies do acquiescers need to be told before they see the obvious? Those who took the job to 'protect themselves' are projected to be those who mostly get sick and die? So what's in the 'vaccine'? The document went on:

It is possible that a summer of low prevalence could be followed by substantial increases in incidence over the following autumn and winter. Low prevalence in late summer should not be taken as an indication that SARS-CoV-2 has retreated or that the population has high enough levels of immunity to prevent another wave.

They are telling you the script and while many British people believed 'Covid' restrictions would end in the summer of 2021 the government was preparing for them to be ongoing. Authorities were awarding contracts for 'Covid marshals' to police the restrictions with contracts starting in July, 2021, and going through to January 31st, 2022, and the government was advertising for 'Media Buying Services' to secure media propaganda slots worth a potential £320 million for 'Covid-19 campaigns' with a contract not ending until March, 2022. The recipient – via a list of other front companies – was reported to be American media marketing giant Omnicom Group

Inc. While money is no object for 'Covid' the UK waiting list for all other treatment – including life-threatening conditions – passed 4.5 million. Meantime the Cult is seeking to control all official 'inquiries' to block revelations about what has really been happening and why. It must not be allowed to – we need Nuremberg jury trials in every country. The cover-up doesn't get more obvious than appointing ultra-Zionist professor Philip Zelikow to oversee two dozen US virologists, public health officials, clinicians, former government officials and four American 'charitable foundations' to 'learn the lessons' of the 'Covid' debacle. The personnel will be those that created and perpetuated the 'Covid' lies while Zelikow is the former executive director of the 9/11 Commission who ensured that the truth about those attacks never came out and produced a report that must be among the most mendacious and manipulative documents ever written – see *The Trigger* for the detailed exposure of the almost unimaginable 9/11 story in which Sabbatians can be found at every level.

## **Passive no more**

People are increasingly challenging the authorities with amazing numbers of people taking to the streets in London well beyond the ability of the Face-Nappies to stop them. Instead the Nappies choose situations away from the mass crowds to target, intimidate, and seek to promote the impression of 'violent protestors'. One such incident happened in London's Hyde Park. Hundreds of thousands walking through the streets in protest against 'Covid' fascism were ignored by the Cult-owned BBC and most of the rest of the mainstream media, but they delighted in reporting how police were injured in 'clashes with protestors'. The truth was that a group of people gathered in Hyde Park at the end of one march when most had gone home and they were peacefully having a good time with music and chat. Face-Nappies who couldn't deal with the full-march crowd then waded in with their batons and got more than they bargained for. Instead of just standing for this criminal brutality the crowd used their numerical superiority to push the Face-Nappies out of the

park. Eventually the Nappies turned and ran. Unfortunately two or three idiots in the crowd threw drink cans striking two officers which gave the media and the government the image they wanted to discredit the 99.9999 percent who were peaceful. The idiots walked straight into the trap and we must always be aware of potential agent provocateurs used by the authorities to discredit their targets.

This response from the crowd – the can people apart – must be a turning point when the public no longer stand by while the innocent are arrested and brutally attacked by the Face-Nappies. That doesn't mean to be violent, that's the last thing we need. We'll leave the violence to the Face-Nappies and government. But it does mean that when the Face-Nappies use violence against peaceful people the numerical superiority is employed to stop them and make citizen's arrests or Common Law arrests for a breach of the peace. The time for being passive in the face of fascism is over.

We are the many, they are the few, and we need to make that count before there is no freedom left and our children and grandchildren face an ongoing fascist nightmare.

*COME ON PEOPLE – IT'S TIME.*

### **One final thought ...**

The power of love  
A force from above  
Cleaning my soul  
Flame on burn desire  
Love with tongues of fire  
Purge the soul  
Make love your goal

I'll protect you from the hooded claw  
Keep the vampires from your door  
When the chips are down I'll be around  
With my undying, death-defying  
Love for you

Envy will hurt itself  
Let yourself be beautiful  
Sparkling love, flowers  
And pearls and pretty girls  
Love is like an energy  
Rushin' rushin' inside of me

This time we go sublime  
Lovers entwine, divine, divine,  
Love is danger, love is pleasure  
Love is pure – the only treasure

I'm so in love with you  
Purge the soul  
Make love your goal

The power of love  
A force from above  
Cleaning my soul  
The power of love  
A force from above  
A sky-scraping dove

Flame on burn desire  
Love with tongues of fire  
Purge the soul  
Make love your goal

**Frankie Goes To Hollywood**



## APPENDIX

### **Cowan-Kaufman-Morell Statement on Virus Isolation (SOVI)**

*Isolation: The action of isolating; the fact or condition of being isolated or standing alone; separation from other things or persons; solitariness*

Oxford English Dictionary

The controversy over whether the SARS-CoV-2 virus has ever been isolated or purified continues. However, using the above definition, common sense, the laws of logic and the dictates of science, any unbiased person must come to the conclusion that the SARS-CoV-2 virus has never been isolated or purified. As a result, no confirmation of the virus' existence can be found. The logical, common sense, and scientific consequences of this fact are:

- the structure and composition of something not shown to exist can't be known, including the presence, structure, and function of any hypothetical spike or other proteins;
- the genetic sequence of something that has never been found can't be known;
- "variants" of something that hasn't been shown to exist can't be known;
- it's impossible to demonstrate that SARS-CoV-2 causes a disease called Covid-19.

In as concise terms as possible, here's the proper way to isolate, characterize and demonstrate a new virus. First, one takes samples (blood, sputum, secretions) from many people (e.g. 500) with symptoms which are unique and specific enough to characterize an illness. Without mixing these samples with ANY tissue or products that also contain genetic material, the virologist macerates, filters and ultracentrifuges i.e. *purifies* the specimen. This common virology technique, done for decades to isolate bacteriophages<sup>1</sup> and so-called giant viruses in every virology lab, then allows the virologist to demonstrate with electron microscopy thousands of identically sized and shaped particles. These particles are the isolated and purified virus.

These identical particles are then checked for uniformity by physical and/or microscopic techniques. Once the purity is determined, the particles may be further characterized. This would include examining the structure, morphology, and chemical composition of the particles. Next, their genetic makeup is characterized by extracting the genetic material directly from the purified particles and using genetic-sequencing techniques, such as Sanger sequencing, that have also been around for decades. Then one does an analysis to confirm that these uniform particles are exogenous (outside) in origin as a virus is conceptualized to be, and not the normal breakdown products of dead and dying tissues.<sup>2</sup> (As of May 2020, we know that virologists have no way to determine whether the particles they're seeing are viruses or just normal breakdown products of dead and dying tissues.)<sup>3</sup>

---

1 Isolation, characterization and analysis of bacteriophages from the haloalkaline lake Elmenteita, Kenya Julia Khayeli Akhwale et al, PLOS One, Published: April 25, 2019.  
<https://journals.plos.org/plosone/article?id=10.1371/journal.pone.0215734> – accessed 2/15/21

---

2 "Extracellular Vesicles Derived From Apoptotic Cells: An Essential Link Between Death and Regeneration," Maojiao Li et al, Frontiers in Cell and Developmental Biology, 2020 October 2.  
<https://www.frontiersin.org/articles/10.3389/fcell.2020.573511/full> – accessed 2/15/21

If we have come this far then we have fully isolated, characterized, and genetically sequenced an exogenous virus particle. However, we still have to show it is causally related to a disease. This is carried out by exposing a group of healthy subjects (animals are usually used) to this isolated, purified virus in the manner in which the disease is thought to be transmitted. If the animals get sick with the same disease, as confirmed by clinical and autopsy findings, one has now shown that the virus actually causes a disease. This demonstrates infectivity and transmission of an infectious agent.

None of these steps has even been attempted with the SARS-CoV-2 virus, nor have all these steps been successfully performed for any so-called pathogenic virus. Our research indicates that a single study showing these steps does not exist in the medical literature.

Instead, since 1954, virologists have taken unpurified samples from a relatively few people, often less than ten, with a similar disease. They then minimally process this sample and inoculate this unpurified sample onto tissue culture containing usually four to six other types of material – all of which contain identical genetic material as to what is called a “virus.” The tissue culture is starved and poisoned and naturally disintegrates into many types of particles, some of which contain genetic material. Against all common sense, logic, use of the English language and scientific integrity, this process is called “virus isolation.” This brew containing fragments of genetic material from many sources is then subjected to genetic analysis, which then creates in a computer-simulation process the alleged sequence of the alleged virus, a so called in silico genome. At no time is an actual virus confirmed by electron microscopy. At no time is a genome extracted and sequenced from an actual virus. This is scientific fraud.

The observation that the unpurified specimen — inoculated onto tissue culture along with toxic antibiotics, bovine fetal tissue, amniotic fluid and other tissues — destroys the kidney tissue onto which it is inoculated is given as evidence of the virus' existence and pathogenicity. This is scientific fraud.

From now on, when anyone gives you a paper that suggests the SARS-CoV-2 virus has been isolated, please check the methods sections. If the researchers used Vero cells or any other culture method, you know that their process was not isolation. You will hear the following excuses for why actual isolation isn't done:

1. There were not enough virus particles found in samples from patients to analyze.
2. Viruses are intracellular parasites; they can't be found outside the cell in this manner.

If No. 1 is correct, and we can't find the virus in the sputum of sick people, then on what evidence do we think the virus is dangerous or even lethal? If No. 2 is correct, then how is the virus spread from person to person? We are told it emerges from the cell to infect others. Then why isn't it possible to find it?

Finally, questioning these virology techniques and conclusions is not some distraction or divisive issue. Shining the light on this truth is essential to stop this terrible fraud that humanity is confronting. For, as we now know, if the virus has never been isolated, sequenced or shown to cause illness, if the virus is imaginary, then why are we wearing masks, social distancing and putting the whole world into prison?

Finally, if pathogenic viruses don't exist, then what is going into those injectable devices erroneously called "vaccines," and what is their purpose? This scientific question is the most urgent and relevant one of our time.

We are correct. The SARS-CoV2 virus does not exist.

Sally Fallon Morell, MA

Dr. Thomas Cowan, MD

Dr. Andrew Kaufman, MD

# Bibliography

- Alinsky, Saul:** *Rules for Radicals* (Vintage, 1989)
- Antelman, Rabbi Marvin:** *To Eliminate the Opiate* (Zahavia, 1974)
- Bastardi, Joe:** *The Climate Chronicles* (Relentless Thunder Press, 2018)
- Cowan, Tom:** *Human Heart, Cosmic Heart* (Chelsea Green Publishing, 2016)
- Cowan, Tom, and Fallon Morell, Sally:** *The Contagion Myth* (Skyhorse Publishing, 2020)
- Forbes, Jack D:** *Columbus And Other Cannibals – The Wetiko Disease of Exploitation, Imperialism, and Terrorism* (Seven Stories Press, 2008 – originally published in 1979)
- Gates, Bill:** *How to Avoid a Climate Disaster: The Solutions We Have and the Breakthroughs We Need* (Allen Lane, 2021)
- Huxley, Aldous:** *Brave New World* (Chatto & Windus, 1932)
- Köhnlein, Dr Claus, and Engelbrecht, Torsten:** *Virus Mania* (emu-Verlag, Lahnstein, 2020)
- Lanza, Robert, and Berman, Bob:** *Biocentrism* (BenBella Books, 2010)
- Lash, John Lamb:** *Not In His Image* (Chelsea Green Publishing, 2006)
- Lester, Dawn, and Parker, David:** *What Really Makes You Ill – Why everything you thought you knew about disease is wrong* (Independently Published, 2019)
- Levy, Paul:** *Dispelling Wetiko, Breaking the Spell of Evil* (North Atlantic Books, 2013)
- Marx, Karl:** *A World Without Jews* (Philosophical Library, first edition, 1959)
- Mullis, Kary:** *Dancing Naked in the Mine Field* (Bloomsbury, 1999)
- O'Brien, Cathy:** *Trance-Formation of America* (Reality Marketing, 1995)
- Scholem, Gershon:** *The Messianic Idea in Judaism* (Schocken Books, 1994)
- Schwab, Klaus, and Davis, Nicholas:** *Shaping the Future of the Fourth Industrial Revolution: A guide to building a better world* (Penguin Books, 2018)
- Schwab, Klaus:** *The Great Reset* (Agentur Schweiz, 2020)
- Sunstein, Cass and Thaler, Richard:** *Nudge: Improving Decisions About Health, Wealth, and Happiness* (Penguin, 2009)
- Swan, Shanna:** *Count Down: How Our Modern World Is Threatening Sperm Counts, Altering Male and Female Reproductive Development and Imperiling the Future of the Human Race* (Scribner, 2021)
- Tegmark, Max:** *Our Mathematical Universe: My Quest for the Ultimate Nature of Reality* (Penguin, 2015)
- Velikovsky, Immanuel:** *Worlds in Collision* (Paradigma, 2009)

**Wilton, Robert:** *The Last Days of the Romanovs* (Blurb, 2018, first published 1920)

# Index

## A

### **abusive relationships**

blaming themselves, abused as [ref1](#)

children [ref1](#), [ref2](#), [ref3](#), [ref4](#), [ref5](#), [ref6](#), [ref7](#), [ref8](#), [ref9](#), [ref10](#)

conspiracy theories [ref1](#)

domestic abuse [ref1](#), [ref2](#)

economic abuse and dependency [ref1](#)

isolation [ref1](#)

physical abuse [ref1](#)

psychological abuse [ref1](#)

signs of abuse [ref1](#)

### **addiction**

alcoholism [ref1](#)

frequencies [ref1](#)

substance abuse [ref1](#), [ref2](#)

technology [ref1](#), [ref2](#), [ref3](#)

**Adelson, Sheldon** [ref1](#), [ref2](#), [ref3](#)

**Agenda 21/Agenda 2030 (UN)** [ref1](#), [ref2](#), [ref3](#), [ref4](#)

**AIDs/HIV** [ref1](#)

causal link between HIV and AIDs [ref1](#), [ref2](#)

retroviruses [ref1](#)

testing [ref1](#), [ref2](#)

trial-run for Covid-19, as [ref1](#), [ref2](#)

**aliens/extraterrestrials** [ref1](#), [ref2](#)

**aluminium** [ref1](#)

**Amazon** [ref1](#), [ref2](#), [ref3](#)



**amplification cycles** [ref1](#), [ref2](#)  
**anaphylactic shock** [ref1](#), [ref2](#), [ref3](#), [ref4](#)  
**animals** [ref1](#), [ref2](#), [ref3](#)  
**antibodies** [ref1](#), [ref2](#), [ref3](#), [ref4](#), [ref5](#)  
**Antifa** [ref1](#), [ref2](#), [ref3](#), [ref4](#)  
**antigens** [ref1](#), [ref2](#)  
**anti-Semitism** [ref1](#), [ref2](#), [ref3](#)  
**Archons** [ref1](#), [ref2](#)  
    consciousness [ref1](#), [ref2](#), [ref3](#)  
    energy [ref1](#), [ref2](#), [ref3](#)  
    ennoia [ref1](#)  
    genetic manipulation [ref1](#), [ref2](#)  
    inversion [ref1](#), [ref2](#), [ref3](#)  
    lockdowns [ref1](#)  
    money [ref1](#)  
    radiation [ref1](#)  
    religion [ref1](#), [ref2](#)  
    technology [ref1](#), [ref2](#), [ref3](#)  
    Wetiko factor [ref1](#), [ref2](#), [ref3](#), [ref4](#)  
**artificial intelligence (AI)** [ref1](#)  
**army made up of robots** [ref1](#), [ref2](#)  
    Human 2.0 [ref1](#), [ref2](#)  
    Internet [ref1](#)  
    MHRA [ref1](#)  
    Morgellons fibres [ref1](#), [ref2](#)  
    Smart Grid [ref1](#)  
    Wetiko factor [ref1](#)  
**asymptomatic, Covid-19 as** [ref1](#), [ref2](#), [ref3](#)  
**aviation industry** [ref1](#)

## **B**

**banking, finance and money** [ref1](#), [ref2](#), [ref3](#)

2008 crisis [ref1](#), [ref2](#)

boom and bust [ref1](#)

cashless digital money systems [ref1](#)

central banks [ref1](#)

credit [ref1](#)

digital currency [ref1](#)

fractional reserve lending [ref1](#)

Great Reset [ref1](#)

guaranteed income [ref1](#), [ref2](#), [ref3](#)

Human 2.0 [ref1](#)

incomes, destruction of [ref1](#), [ref2](#)

interest [ref1](#)

one per cent [ref1](#), [ref2](#)

scams [ref1](#)

**BBC** [ref1](#), [ref2](#), [ref3](#), [ref4](#), [ref5](#), [ref6](#), [ref7](#), [ref8](#)

**Becker-Phelps, Leslie** [ref1](#)

**Behavioural Insights Team (BIT) (Nudge Unit)** [ref1](#), [ref2](#), [ref3](#)

**behavioural scientists *and* psychologists, advice from** [ref1](#), [ref2](#)

**Bezos, Jeff** [ref1](#), [ref2](#), [ref3](#), [ref4](#)

**Biden, Hunter** [ref1](#)

**Biden, Joe** [ref1](#), [ref2](#), [ref3](#), [ref4](#), [ref5](#), [ref6](#), [ref7](#), [ref8](#), [ref9](#), [ref10](#), [ref11](#),  
[ref12](#), [ref13](#), [ref14](#), [ref15](#), [ref16](#), [ref17](#)

**Big Pharma**

cholesterol [ref1](#)

health professionals [ref1](#), [ref2](#)

immunity from prosecution in US [ref1](#)

vaccines [ref1](#), [ref2](#), [ref3](#), [ref4](#), [ref5](#), [ref6](#), [ref7](#), [ref8](#)

Wetiko factor [ref1](#), [ref2](#)

WHO [ref1](#), [ref2](#), [ref3](#)

**Bill and Melinda Gates Foundation** [ref1](#), [ref2](#), [ref3](#), [ref4](#), [ref5](#), [ref6](#),  
[ref7](#)

**billionaires** [ref1](#), [ref2](#), [ref3](#), [ref4](#), [ref5](#), [ref6](#), [ref7](#), [ref8](#), [ref9](#) [ref10](#), [ref11](#)

**bird flu (H5N1)** [ref1](#)

**Black Lives Matter (BLM)** [ref1](#), [ref2](#), [ref3](#), [ref4](#), [ref5](#)

**Blair, Tony** [ref1](#), [ref2](#), [ref3](#), [ref4](#), [ref5](#), [ref6](#), [ref7](#)

**Brin, Sergei** [ref1](#), [ref2](#), [ref3](#), [ref4](#), [ref5](#), [ref6](#), [ref7](#)

**British Empire** [ref1](#)

**Bush, George HW** [ref1](#), [ref2](#)

**Bush, George W** [ref1](#), [ref2](#), [ref3](#), [ref4](#)

**Byrd, Robert** [ref1](#)

## **C**

### **Canada**

Global Cult [ref1](#)

hate speech [ref1](#)

internment [ref1](#)

masks [ref1](#)

old people [ref1](#)

SARS-COV-2 [ref1](#)

satellites [ref1](#)

vaccines [ref1](#)

wearable technology [ref1](#)

**Capitol Hill riot** [ref1](#), [ref2](#)

agents provocateur [ref1](#)

Antifa [ref1](#)

Black Lives Matter (BLM) [ref1](#), [ref2](#)

QAnon [ref1](#)

security precautions, lack of [ref1](#), [ref2](#), [ref3](#)

**carbon dioxide** [ref1](#), [ref2](#)

**care homes, deaths in** [ref1](#), [ref2](#)

**cashless digital money systems** [ref1](#)

**censorship** [ref1](#), [ref2](#), [ref3](#), [ref4](#), [ref5](#)

fact-checkers [ref1](#)

masks [ref1](#)

media [ref1](#), [ref2](#)

private messages [ref1](#)

social media [ref1](#), [ref2](#), [ref3](#), [ref4](#), [ref5](#), [ref6](#)

transgender persons [ref1](#)

vaccines [ref1](#), [ref2](#), [ref3](#)

Wokeness [ref1](#)

**Centers for Disease Control (CDC) (United States)** [ref1](#), [ref2](#), [ref3](#),  
[ref4](#), [ref5](#), [ref6](#), [ref7](#), [ref8](#), [ref9](#), [ref10](#), [ref11](#), [ref12](#), [ref13](#)

**centralisation** [ref1](#), [ref2](#), [ref3](#), [ref4](#), [ref5](#), [ref6](#), [ref7](#), [ref8](#)

**chakras** [ref1](#)

**change agents** [ref1](#), [ref2](#), [ref3](#)

**chemtrails** [ref1](#), [ref2](#), [ref3](#)

**chief medical officers and scientific advisers** [ref1](#), [ref2](#), [ref3](#), [ref4](#),  
[ref5](#), [ref6](#)

**children** *see also* **young people**

abuse [ref1](#), [ref2](#), [ref3](#), [ref4](#), [ref5](#), [ref6](#), [ref7](#), [ref8](#), [ref9](#), [ref10](#)

care, taken into [ref1](#), [ref2](#), [ref3](#)

education [ref1](#), [ref2](#), [ref3](#), [ref4](#)

energy [ref1](#)

family courts [ref1](#)

hand sanitisers [ref1](#)

human sacrifice [ref1](#)

lockdowns [ref1](#), [ref2](#), [ref3](#)

masks [ref1](#), [ref2](#), [ref3](#), [ref4](#), [ref5](#)

mental health [ref1](#)

old people [ref1](#)

parents, replacement of [ref1](#), [ref2](#)

Psyop (psychological operation), Covid as a [ref1](#), [ref2](#)

reframing [ref1](#)

smartphone addiction [ref1](#)

social distancing and isolation [ref1](#)  
social media [ref1](#)  
transgender persons [ref1](#), [ref2](#)  
United States [ref1](#)  
vaccines [ref1](#), [ref2](#), [ref3](#), [ref4](#), [ref5](#), [ref6](#), [ref7](#), [ref8](#), [ref9](#), [ref10](#)  
Wetiko factor [ref1](#)

## **China** [ref1](#), [ref2](#), [ref3](#), [ref4](#)

anal swab tests [ref1](#)  
**Chinese Revolution** [ref1](#), [ref2](#), [ref3](#)  
digital currency [ref1](#)  
Global Cult [ref1](#), [ref2](#), [ref3](#), [ref4](#), [ref5](#), [ref6](#), [ref7](#), [ref8](#), [ref9](#)  
guaranteed income [ref1](#)  
Imperial College [ref1](#)  
Israel [ref1](#)  
lockdown [ref1](#), [ref2](#)  
masculinity crisis [ref1](#)  
masks [ref1](#)  
media [ref1](#)  
origins of virus in China [ref1](#), [ref2](#), [ref3](#), [ref4](#), [ref5](#)  
pollution causing respiratory diseases [ref1](#)  
Sabbatians [ref1](#), [ref2](#)  
Smart Grid [ref1](#), [ref2](#)  
social credit system [ref1](#)  
testing [ref1](#), [ref2](#)  
United States [ref1](#), [ref2](#)  
vaccines [ref1](#), [ref2](#)  
Wetiko factor [ref1](#)  
wet market conspiracy [ref1](#)  
Wuhan [ref1](#), [ref2](#), [ref3](#), [ref4](#), [ref5](#), [ref6](#), [ref7](#)

## **cholesterol** [ref1](#), [ref2](#)

## **Christianity** [ref1](#), [ref2](#), [ref3](#), [ref4](#), [ref5](#)

criticism [ref1](#)  
cross, inversion of the [ref1](#)

Nag Hammadi texts [ref1](#), [ref2](#), [ref3](#)

Roman Catholic Church [ref1](#), [ref2](#)

Sabbatians [ref1](#), [ref2](#)

Satan [ref1](#), [ref2](#), [ref3](#), [ref4](#)

Wokeness [ref1](#)

**class** [ref1](#), [ref2](#)

**climate change hoax** [ref1](#), [ref2](#), [ref3](#), [ref4](#), [ref5](#)

Agenda 21/Agenda 2030 [ref1](#), [ref2](#), [ref3](#)

carbon dioxide [ref1](#), [ref2](#)

Club of Rome [ref1](#), [ref2](#), [ref3](#), [ref4](#), [ref5](#)

fear [ref1](#)

funding [ref1](#)

Global Cult [ref1](#)

green new deals [ref1](#)

green parties [ref1](#)

inversion [ref1](#)

perception, control of [ref1](#)

PICC [ref1](#)

reframing [ref1](#)

temperature, increases in [ref1](#)

United Nations [ref1](#), [ref2](#)

Wikipedia [ref1](#)

Wokeness [ref1](#), [ref2](#)

**Clinton, Bill** [ref1](#), [ref2](#), [ref3](#), [ref4](#), [ref5](#), [ref6](#)

**Clinton, Hillary** [ref1](#), [ref2](#), [ref3](#)

**the cloud** [ref1](#), [ref2](#), [ref3](#), [ref4](#), [ref5](#), [ref6](#), [ref7](#)

**Club of Rome and climate change hoax** [ref1](#), [ref2](#), [ref3](#), [ref4](#), [ref5](#)

**cognitive therapy** [ref1](#)

**Cohn, Roy** [ref1](#)

**Common Law** [ref1](#)

Admiralty Law [ref1](#)

arrests [ref1](#), [ref2](#)

contractual law, Statute Law as [ref1](#)

corporate entities, people as [ref1](#)

legalese [ref1](#)

sea, law of the [ref1](#)

Statute Law [ref1](#)

**Common Purpose leadership programme** [ref1](#), [ref2](#)

**communism** [ref1](#), [ref2](#)

**co-morbidities** [ref1](#)

**computer-generated virus,**

**Covid-19** as [ref1](#), [ref2](#), [ref3](#)

**computer models** [ref1](#), [ref2](#), [ref3](#), [ref4](#), [ref5](#)

**connections** [ref1](#), [ref2](#), [ref3](#), [ref4](#)

**consciousness** [ref1](#), [ref2](#), [ref3](#), [ref4](#)

Archons [ref1](#), [ref2](#), [ref3](#)

expanded [ref1](#), [ref2](#), [ref3](#), [ref4](#), [ref5](#), [ref6](#), [ref7](#)

experience [ref1](#)

heart [ref1](#)

infinity [ref1](#), [ref2](#)

religion [ref1](#), [ref2](#)

self-identity [ref1](#)

simulation thesis [ref1](#)

vaccines [ref1](#)

Wetiko factor [ref1](#), [ref2](#)

**conspiracy theorists** [ref1](#), [ref2](#), [ref3](#), [ref4](#), [ref5](#)

**contradictory rules** [ref1](#)

**contrails** [ref1](#)

**Corman-Drosten test** [ref1](#), [ref2](#), [ref3](#), [ref4](#)

**countermimicry** [ref1](#), [ref2](#), [ref3](#)

**Covid-19 vaccines** *see* vaccines

**Covidiots** [ref1](#), [ref2](#)

**Cowan, Tom** [ref1](#), [ref2](#), [ref3](#), [ref4](#)

**crimes against humanity** [ref1](#), [ref2](#), [ref3](#), [ref4](#), [ref5](#), [ref6](#), [ref7](#), [ref8](#)

cyber-operations [ref1](#)

cyberwarfare [ref1](#)

## **D**

DARPA (Defense Advanced Research Projects Agency) [ref1](#)

deaths

care homes [ref1](#)

certificates [ref1](#), [ref2](#), [ref3](#), [ref4](#)

mortality rate [ref1](#)

post-mortems/autopsies [ref1](#)

recording [ref1](#), [ref2](#), [ref3](#), [ref4](#), [ref5](#), [ref6](#), [ref7](#)

vaccines [ref1](#), [ref2](#), [ref3](#), [ref4](#), [ref5](#)

deceit

pyramid of deceit [ref1](#), [ref2](#)

sequence of deceit [ref1](#)

decoding [ref1](#), [ref2](#), [ref3](#)

dehumanisation [ref1](#), [ref2](#), [ref3](#)

Delphi technique [ref1](#)

democracy [ref1](#)

dependency [ref1](#), [ref2](#), [ref3](#), [ref4](#), [ref5](#)

Descartes, René [ref1](#)

DNA

numbers [ref1](#)

vaccines [ref1](#), [ref2](#), [ref3](#), [ref4](#), [ref5](#), [ref6](#), [ref7](#), [ref8](#), [ref9](#), [ref10](#)

DNR (do not resuscitate)

orders [ref1](#)

domestic abuse [ref1](#), [ref2](#)

downgrading of Covid-19 [ref1](#)

Drosten, Christian [ref1](#), [ref2](#), [ref3](#), [ref4](#), [ref5](#), [ref6](#), [ref7](#)

Duesberg, Peter [ref1](#), [ref2](#)



## **E**

**economic abuse** [ref1](#)

**Edmunds, John** [ref1](#), [ref2](#)

**education** [ref1](#), [ref2](#), [ref3](#), [ref4](#)

**electromagnetic spectrum** [ref1](#), [ref2](#)

**Enders, John** [ref1](#)

**energy**

Archons [ref1](#), [ref2](#), [ref3](#)

children and young people [ref1](#)

consciousness [ref1](#)

decoding [ref1](#)

frequencies [ref1](#), [ref2](#), [ref3](#), [ref4](#)

heart [ref1](#)

human energy field [ref1](#)

source, humans as an energy [ref1](#), [ref2](#)

vaccines [ref1](#)

viruses [ref1](#)

**ennoia** [ref1](#)

**Epstein, Jeffrey** [ref1](#), [ref2](#)

**eternal 'I'** [ref1](#), [ref2](#)

**ethylene oxide** [ref1](#)

**European Union** [ref1](#), [ref2](#), [ref3](#), [ref4](#)

**Event** [ref1](#) *and* **Bill Gates** [ref2](#)

**exosomes, Covid-19 as natural defence mechanism called** [ref1](#)

**experience** [ref1](#), [ref2](#)

**Extinction Rebellion** [ref1](#), [ref2](#)

## **F**

**Facebook**

addiction [ref1](#), 448–50

Facebook

Archons [ref1](#)

ensorship [ref1](#), [ref2](#), [ref3](#)

hate speech [ref1](#)

monopoly, as [ref1](#)

private messages, censorship of [ref1](#)

Sabbatians [ref1](#)

United States election fraud [ref1](#)

vaccines [ref1](#)

Wetiko factor [ref1](#)

**fact-checkers** [ref1](#)

**Fauci, Anthony** [ref1](#), [ref2](#), [ref3](#), [ref4](#), [ref5](#), [ref6](#), [ref7](#), [ref8](#), [ref9](#), [ref10](#),  
[ref11](#), [ref12](#)

**fear** [ref1](#), [ref2](#), [ref3](#), [ref4](#)

climate change [ref1](#)

computer models [ref1](#)

conspiracy theories [ref1](#)

empty hospitals [ref1](#)

Italy [ref1](#), [ref2](#), [ref3](#)

lockdowns [ref1](#), [ref2](#), [ref3](#), [ref4](#)

masks [ref1](#), [ref2](#)

media [ref1](#), [ref2](#)

medical staff [ref1](#)

Psyop (psychological operation), Covid as a [ref1](#)

Wetiko factor [ref1](#), [ref2](#)

**female infertility** [ref1](#)

**Fermi Paradox** [ref1](#)

**Ferguson, Neil** [ref1](#), [ref2](#), [ref3](#), [ref4](#), [ref5](#), [ref6](#), [ref7](#)

**fertility, decline in** [ref1](#)

**The Field** [ref1](#), [ref2](#), [ref3](#), [ref4](#), [ref5](#), [ref6](#), [ref7](#), [ref8](#)

**finance** *see* **banking, finance and money**

**five-senses** [ref1](#), [ref2](#)

Archons [ref1](#), [ref2](#), [ref3](#)

censorship [ref1](#)  
    consciousness, expansion of [ref1](#), [ref2](#), [ref3](#), [ref4](#), [ref5](#), [ref6](#)  
    decoding [ref1](#)  
    education [ref1](#), [ref2](#)  
    the Field [ref1](#), [ref2](#)  
    God, personification of [ref1](#)  
    infinity [ref1](#), [ref2](#)  
    media [ref1](#)  
    paranormal [ref1](#)  
    perceptual programming [ref1](#), [ref2](#)  
    Phantom Self [ref1](#)  
    pneuma not nous, using [ref1](#)  
    reincarnation [ref1](#)  
    self-identity [ref1](#)  
    Wetiko factor [ref1](#), [ref2](#), [ref3](#), [ref4](#), [ref5](#), [ref6](#)  
**5G** [ref1](#), [ref2](#), [ref3](#), [ref4](#), [ref5](#), [ref6](#), [ref7](#), [ref8](#)  
**Floyd, George and protests, killing of** [ref1](#)  
**flu, re-labelling of** [ref1](#), [ref2](#), [ref3](#)  
**food and water, control of** [ref1](#), [ref2](#)  
**Freemasons** [ref1](#), [ref2](#), [ref3](#), [ref4](#), [ref5](#), [ref6](#)  
**Frei, Rosemary** [ref1](#)  
**frequencies**  
    addictions [ref1](#)  
    Archons [ref1](#), [ref2](#), [ref3](#)  
    awareness [ref1](#)  
    chanting and mantras [ref1](#)  
    consciousness [ref1](#)  
    decoding [ref1](#), [ref2](#)  
    education [ref1](#)  
    electromagnetic (EMF) frequencies [ref1](#)  
    energy [ref1](#), [ref2](#), [ref3](#), [ref4](#)  
    fear [ref1](#)

the Field [ref1](#), [ref2](#) 5G [ref3](#), [ref4](#), [ref5](#), [ref6](#), [ref7](#), [ref8](#), [ref9](#), [ref10](#)  
five-senses [ref1](#), [ref2](#)  
ghosts [ref1](#)  
Gnostics [ref1](#)  
hive-minds [ref1](#)  
human, meaning of [ref1](#)  
light [ref1](#), [ref2](#)  
love [ref1](#), [ref2](#)  
magnetism [ref1](#)  
perception [ref1](#)  
reality [ref1](#), [ref2](#), [ref3](#)  
simulation [ref1](#)  
terror [ref1](#)  
vaccines [ref1](#)  
Wetiko [ref1](#), [ref2](#), [ref3](#)

**Fuellmich, Reiner** [ref1](#), [ref2](#), [ref3](#)

**furlough/rescue payments** [ref1](#)

## **G**

**Gallo, Robert** [ref1](#), [ref2](#), [ref3](#)

**Gates, Bill**

Archons [ref1](#), [ref2](#), [ref3](#)  
climate change [ref1](#), [ref2](#), [ref3](#), [ref4](#)  
Daily Pass tracking system [ref1](#)  
Epstein [ref1](#)  
fascism [ref1](#)  
five senses [ref1](#)  
GAVI [ref1](#)  
Great Reset [ref1](#)  
GSK [ref1](#)  
Imperial College [ref1](#), [ref2](#)  
Johns Hopkins University [ref1](#), [ref2](#), [ref3](#)

lockdowns [ref1](#), [ref2](#)

masks [ref1](#)

Nuremberg trial, proposal for [ref1](#), [ref2](#)

Rockefellers [ref1](#), [ref2](#)

social distancing and isolation [ref1](#)

Sun, dimming the [ref1](#)

synthetic meat [ref1](#), [ref2](#)

vaccines [ref1](#), [ref2](#), [ref3](#), [ref4](#), [ref5](#), [ref6](#), [ref7](#)

Wellcome Trust [ref1](#)

Wetiko factor [ref1](#), [ref2](#), [ref3](#)

WHO [ref1](#), [ref2](#), [ref3](#), [ref4](#), [ref5](#), [ref6](#), [ref7](#), [ref8](#), [ref9](#), [ref10](#)

Wokeness [ref1](#)

World Economic Forum [ref1](#), [ref2](#), [ref3](#), [ref4](#)

**Gates, Melinda** [ref1](#), [ref2](#), [ref3](#)

**GAVI vaccine alliance** [ref1](#)

**genetics, manipulation of** [ref1](#), [ref2](#), [ref3](#)

**Germany** [ref1](#), [ref2](#), [ref3](#), [ref4](#), [ref5](#), [ref6](#) *see also* **Nazi Germany**

**Global Cult** [ref1](#), [ref2](#), [ref3](#), [ref4](#), [ref5](#)

anti-human, why Global Cult is [ref1](#)

Black Lives Matter (BLM) [ref1](#), [ref2](#), [ref3](#), [ref4](#)

China [ref1](#), [ref2](#), [ref3](#), [ref4](#), [ref5](#), [ref6](#), [ref7](#), [ref8](#), [ref9](#)

climate change hoax [ref1](#)

contradictory rules [ref1](#)

Covid-19 [ref1](#), [ref2](#), [ref3](#)

fascism [ref1](#)

geographical origins [ref1](#)

immigration [ref1](#)

Internet [ref1](#)

mainstream media [ref1](#), [ref2](#)

masks [ref1](#), [ref2](#)

monarchy [ref1](#)

non-human dimension [ref1](#)

perception [ref1](#)  
political parties [ref1](#), [ref2](#)  
pyramidal hierarchy [ref1](#), [ref2](#), [ref3](#)  
reframing [ref1](#)  
Sabbatian-Frankism [ref1](#), [ref2](#)  
science, manipulation of [ref1](#)  
spider and the web [ref1](#)  
transgender persons [ref1](#)  
vaccines [ref1](#)  
who controls the Cult [ref1](#)  
Wokeness [ref1](#), [ref2](#), [ref3](#), [ref4](#)

**globalisation** [ref1](#), [ref2](#)

**Gnostics** [ref1](#), [ref2](#), [ref3](#), [ref4](#), [ref5](#)

**Google** [ref1](#), [ref2](#), [ref3](#), [ref4](#)

**government**

behavioural scientists and psychologists, advice from [ref1](#), [ref2](#)

definition [ref1](#)

Joint Biosecurity Centre (JBC) [ref1](#)

people, abusive relationship with [ref1](#)

**Great Reset** [ref1](#), [ref2](#), [ref3](#), [ref4](#), [ref5](#), [ref6](#)

fascism [ref1](#), [ref2](#), [ref3](#)

financial system [ref1](#)

Human 2.0 [ref1](#)

water and food, control of [ref1](#)

**green parties** [ref1](#)

**Griesz-Brisson, Margarite** [ref1](#)

**guaranteed income** [ref1](#), [ref2](#), [ref3](#)

**H**

**Hancock, Matt** [ref1](#), [ref2](#), [ref3](#), [ref4](#), [ref5](#)

**hand sanitisers** [ref1](#)

**heart** [ref1](#), [ref2](#)

**hive-minds/groupthink** [ref1](#), [ref2](#), [ref3](#)

**holographs** [ref1](#), [ref2](#), [ref3](#), [ref4](#)

**hospitals, empty** [ref1](#)

**human, meaning of** [ref1](#)

**Human 2.0** [ref1](#)

addiction to technology [ref1](#)

artificial intelligence (AI) [ref1](#), [ref2](#)

elimination of Human 1.0 [ref1](#)

fertility, decline in [ref1](#)

Great Reset [ref1](#)

implantables [ref1](#)

money [ref1](#)

mRNA [ref1](#)

nanotechnology [ref1](#)

parents, replacement of [ref1](#), [ref2](#)

Smart Grid, connection to [ref1](#), [ref2](#)

synthetic biology [ref1](#), [ref2](#), [ref3](#), [ref4](#)

testosterone levels, decrease in [ref1](#)

transgender = transhumanism [ref1](#), [ref2](#), [ref3](#)

vaccines [ref1](#), [ref2](#), [ref3](#), [ref4](#)

**human sacrifice** [ref1](#), [ref2](#), [ref3](#)

**Hunger Games Society** [ref1](#), [ref2](#), [ref3](#), [ref4](#), [ref5](#), [ref6](#), [ref7](#)

**Huxley, Aldous** [ref1](#), [ref2](#), [ref3](#)

**I**

**identity politics** [ref1](#), [ref2](#), [ref3](#)

**Illuminati** [ref1](#), [ref2](#)

**illusory physical reality** [ref1](#)

**immigration** [ref1](#), [ref2](#), [ref3](#), [ref4](#)

**Imperial College** [ref1](#), [ref2](#), [ref3](#), [ref4](#), [ref5](#), [ref6](#)

**implantables** [ref1](#), [ref2](#)

**incomes, destruction of** [ref1](#), [ref2](#)

**Infinite Awareness** [ref1](#), [ref2](#), [ref3](#), [ref4](#)

**Internet** [ref1](#), [ref2](#) *see also* social media

artificial intelligence (AI) [ref1](#)

independent journalism, lack of [ref1](#)

Internet of Bodies (IoB) [ref1](#)

**Internet of Everything (IoE)** [ref1](#), [ref2](#)

**Internet of Things (IoT)** [ref1](#), [ref2](#)

**lockdowns** [ref1](#)

Psyop (psychological operation), Covid as a [ref1](#)  
trolls [ref1](#)

**intersectionality** [ref1](#)

**inversion**

Archons [ref1](#), [ref2](#), [ref3](#)

climate change hoax [ref1](#)

energy [ref1](#)

Judaism [ref1](#), [ref2](#), [ref3](#)

symbolism [ref1](#)

Wetiko factor [ref1](#)

Wokeness [ref1](#), [ref2](#), [ref3](#)

**Islam**

Archons [ref1](#)

crypto-Jews [ref1](#)

Islamic State [ref1](#), [ref2](#)

Jinn and Djinn [ref1](#), [ref2](#), [ref3](#)

Ottoman Empire [ref1](#)

Wahhabism [ref1](#)

**isolation** *see* **social distancing** *and* **isolation**

**Israel**

China [ref1](#)

Cyber Intelligence Unit Beersheba complex [ref1](#)

expansion of illegal settlements [ref1](#)



formation [ref1](#)  
Global Cult [ref1](#)  
Judaism [ref1](#), [ref2](#), [ref3](#), [ref4](#), [ref5](#)  
medical experiments, consent for [ref1](#)  
Mossad [ref1](#), [ref2](#), [ref3](#), [ref4](#)  
Palestine-Israel conflict [ref1](#), [ref2](#), [ref3](#)  
parents, replacement of [ref1](#)  
Sabbatians [ref1](#), [ref2](#), [ref3](#), [ref4](#), [ref5](#)  
September 11, 2001, terrorist attacks on United States [ref1](#)  
Silicon Valley [ref1](#)  
Smart Grid [ref1](#), [ref2](#)  
United States [ref1](#), [ref2](#)  
vaccines [ref1](#)  
Wetiko factor [ref1](#)

## **Italy**

fear [ref1](#), [ref2](#), [ref3](#)  
Lombardy [ref1](#), [ref2](#), [ref3](#)  
vaccines [ref1](#)

## **J**

**Johns Hopkins University** [ref1](#), [ref2](#), [ref3](#), [ref4](#), [ref5](#), [ref6](#), [ref7](#)  
**Johnson, Boris** [ref1](#), [ref2](#), [ref3](#), [ref4](#), [ref5](#), [ref6](#), [ref7](#), [ref8](#)  
**Joint Biosecurity Centre (JBC)** [ref1](#)

## **Judaism**

anti-Semitism [ref1](#), [ref2](#), [ref3](#)  
Archons [ref1](#), [ref2](#)  
crypto-Jews [ref1](#)  
inversion [ref1](#), [ref2](#), [ref3](#)  
Israel [ref1](#), [ref2](#), [ref3](#), [ref4](#), [ref5](#)  
Labour Party [ref1](#)  
Nazi Germany [ref1](#), [ref2](#), [ref3](#), [ref4](#)  
Sabbatians [ref1](#), [ref2](#), [ref3](#), [ref4](#), [ref5](#)

Silicon Valley [ref1](#)  
Torah [ref1](#)  
United States [ref1](#), [ref2](#)  
Zionists [ref1](#), [ref2](#), [ref3](#)

## **K**

Kaufman, Andrew [ref1](#), [ref2](#), [ref3](#), [ref4](#)  
knowledge [ref1](#), [ref2](#), [ref3](#), [ref4](#), [ref5](#), [ref6](#)  
Koch's postulates [ref1](#)  
Kurzweil, Ray [ref1](#), [ref2](#), [ref3](#), [ref4](#), [ref5](#), [ref6](#), [ref7](#)  
Kushner, Jared [ref1](#), [ref2](#)

## **L**

Labour Party [ref1](#), [ref2](#)  
Lanka, Stefan [ref1](#), [ref2](#)  
Lateral Flow Device (LFD) [ref1](#)  
Levy, Paul [ref1](#), [ref2](#), [ref3](#)  
Life Program [ref1](#)  
lockdowns [ref1](#), [ref2](#), [ref3](#)  
    amplification tampering [ref1](#)  
    Archons [ref1](#)  
    Behavioural Insights Team [ref1](#)  
    Black Lives Matter (BLM) [ref1](#)  
    care homes, deaths in [ref1](#)  
    children  
abuse [ref1](#), [ref2](#)  
mental health [ref1](#)  
    China [ref1](#), [ref2](#)  
    computer models [ref1](#)  
    consequences [ref1](#), [ref2](#)  
    dependency [ref1](#), [ref2](#), [ref3](#)

domestic abuse [ref1](#)  
fall in cases [ref1](#)  
fear [ref1](#), [ref2](#), [ref3](#), [ref4](#)  
guaranteed income [ref1](#)  
Hunger Games Society [ref1](#), [ref2](#), [ref3](#)  
interaction, destroying [ref1](#)  
Internet [ref1](#), [ref2](#)  
overdoses [ref1](#)  
perception [ref1](#)  
police-military state [ref1](#), [ref2](#)  
protests [ref1](#), [ref2](#), [ref3](#), [ref4](#), [ref5](#)  
psychopathic personality [ref1](#), [ref2](#), [ref3](#)  
reporting/snitching, encouragement of [ref1](#), [ref2](#)  
testing [ref1](#)  
vaccines [ref1](#)  
Wetiko factor [ref1](#)  
WHO [ref1](#)  
**love** [ref1](#), [ref2](#), [ref3](#)  
**Lucifer** [ref1](#), [ref2](#), [ref3](#)

## **M**

**Madej, Carrie** [ref1](#), [ref2](#)  
**Magufuli, John** [ref1](#), [ref2](#)  
**mainstream media** [ref1](#)  
BBC [ref1](#), [ref2](#), [ref3](#), [ref4](#), [ref5](#), [ref6](#), [ref7](#), [ref8](#)  
censorship [ref1](#), [ref2](#)  
China [ref1](#)  
climate change hoax [ref1](#)  
fear [ref1](#), [ref2](#)  
Global Cult [ref1](#), [ref2](#)  
independent journalism, lack of [ref1](#)  
Ofcom [ref1](#), [ref2](#), [ref3](#)

perception [ref1](#), [ref2](#)

Psyop (psychological operation), Covid as a [ref1](#)

Sabbatians [ref1](#), [ref2](#)

social disapproval [ref1](#)

social distancing and isolation [ref1](#)

United States [ref1](#), [ref2](#)

vaccines [ref1](#), [ref2](#), [ref3](#), [ref4](#), [ref5](#)

**Mao Zedong** [ref1](#), [ref2](#), [ref3](#)

**Marx and Marxism** [ref1](#), [ref2](#), [ref3](#), [ref4](#), [ref5](#), [ref6](#)

**masculinity** [ref1](#)

**masks/face coverings** [ref1](#), [ref2](#), [ref3](#)

    censorship [ref1](#)

    children [ref1](#), [ref2](#), [ref3](#), [ref4](#), [ref5](#)

    China, made in [ref1](#)

    dehumanisation [ref1](#), [ref2](#), [ref3](#)

    fear [ref1](#), [ref2](#)

    flu [ref1](#)

    health professionals [ref1](#), [ref2](#), [ref3](#), [ref4](#)

    isolation [ref1](#)

    laughter [ref1](#)

**mass non-cooperation** [ref1](#)

**microplastics, risk of** [ref1](#)

**mind control** [ref1](#)

**multiple masks** [ref1](#)

oxygen deficiency [ref1](#), [ref2](#), [ref3](#)

police [ref1](#), [ref2](#), [ref3](#), [ref4](#), [ref5](#)

pollution, as cause of plastic [ref1](#)

Psyop (psychological operation), Covid as a [ref1](#)

reframing [ref1](#), [ref2](#)

risk assessments, lack of [ref1](#), [ref2](#)

self-respect [ref1](#)

surgeons [ref1](#)

United States [ref1](#)  
vaccines [ref1](#), [ref2](#), [ref3](#), [ref4](#), [ref5](#)  
Wetiko factor [ref1](#)  
'worms' [ref1](#)  
*The Matrix* movies [ref1](#), [ref2](#), [ref3](#)  
measles [ref1](#), [ref2](#)  
media see mainstream media  
Medicines and Healthcare products Regulatory Agency (MHRA)  
[ref1](#), [ref2](#), [ref3](#), [ref4](#)  
**Mesopotamia** [ref1](#)  
**messaging** [ref1](#)  
**military-police state** [ref1](#), [ref2](#), [ref3](#)  
**mind control** [ref1](#), [ref2](#), [ref3](#), [ref4](#), [ref5](#), [ref6](#) *see also* MKUltra  
MKUltra [ref1](#), [ref2](#), [ref3](#)  
**monarchy** [ref1](#)  
**money** *see* **banking, finance and money**  
**Montagnier, Luc** [ref1](#), [ref2](#), [ref3](#)  
**Mooney, Bel** [ref1](#)  
**Morgellons disease** [ref1](#), [ref2](#)  
**mortality rate** [ref1](#)  
**Mullis, Kary** [ref1](#), [ref2](#), [ref3](#)  
**Musk, Elon** [ref1](#)

## **N**

**Nag Hammadi texts** [ref1](#), [ref2](#), [ref3](#)  
**nanotechnology** [ref1](#), [ref2](#), [ref3](#)  
**narcissism** [ref1](#)  
**Nazi Germany** [ref1](#), [ref2](#), [ref3](#), [ref4](#), [ref5](#), [ref6](#), [ref7](#), [ref8](#)  
**near-death experiences** [ref1](#), [ref2](#)  
**Neocons** [ref1](#), [ref2](#), [ref3](#)

**Neuro-Linguistic Programming (NLP) and the Delphi technique**  
[ref1](#)

**NHS (National Health Service)**

amplification cycles [ref1](#)

Common Purpose [ref1](#), [ref2](#)

mind control [ref1](#)

**NHS England** [ref1](#)

saving the NHS [ref1](#), [ref2](#)

vaccines [ref1](#), [ref2](#), [ref3](#), [ref4](#), [ref5](#)

whistle-blowers [ref1](#), [ref2](#), [ref3](#)

**No-Problem-Reaction-Solution** [ref1](#), [ref2](#), [ref3](#), [ref4](#)

**non-human dimension of Global Cult** [ref1](#)

**nous** [ref1](#)

**numbers, reality as** [ref1](#)

**Nuremberg Codes** [ref1](#), [ref2](#), [ref3](#)

**Nuremberg-like tribunal, proposal for** [ref1](#), [ref2](#), [ref3](#), [ref4](#), [ref5](#),  
[ref6](#), [ref7](#), [ref8](#), [ref9](#), [ref10](#), [ref11](#), [ref12](#)

## **O**

**Obama, Barack** [ref1](#), [ref2](#), [ref3](#), [ref4](#), [ref5](#), [ref6](#), [ref7](#), [ref8](#), [ref9](#), [ref10](#)

**O'Brien, Cathy** [ref1](#), [ref2](#), [ref3](#), [ref4](#)

**Ochel, Evita** [ref1](#)

**Ofcom** [ref1](#), [ref2](#), [ref3](#)

**old people** [ref1](#), [ref2](#), [ref3](#), [ref4](#), [ref5](#)

**Oneness** [ref1](#), [ref2](#), [ref3](#)

**Open Society Foundations (Soros)** [ref1](#), [ref2](#), [ref3](#)

**oxygen** 406, 528–34

## **P**

**paedophilia** [ref1](#), [ref2](#)

**Page, Larry** [ref1](#), [ref2](#), [ref3](#), [ref4](#), [ref5](#), [ref6](#), [ref7](#)

**Palestine-Israel conflict** [ref1](#), [ref2](#), [ref3](#)

**pandemic, definition of** [ref1](#)

**pandemic and health crisis scenarios/simulations** [ref1](#), [ref2](#), [ref3](#),  
[ref4](#)

**paranormal** [ref1](#)

**PCR tests** [ref1](#), [ref2](#), [ref3](#), [ref4](#), [ref5](#), [ref6](#), [ref7](#), [ref8](#)

**Pearl Harbor attacks, prior knowledge of** [ref1](#)

**Pelosi, Nancy** [ref1](#), [ref2](#), [ref3](#)

**perception** [ref1](#), [ref2](#), [ref3](#), [ref4](#)

climate change hoax [ref1](#)

control [ref1](#), [ref2](#), [ref3](#)

decoding [ref1](#), [ref2](#)

enslavement [ref1](#)

externally-delivered perceptions [ref1](#)

five senses [ref1](#)

human labels [ref1](#)

media [ref1](#), [ref2](#)

political parties [ref1](#), [ref2](#)

Psyop (psychological operation), Covid as a [ref1](#)

sale of perception [ref1](#)

self-identity [ref1](#), [ref2](#)

Wokeness [ref1](#)

**Phantom Self** [ref1](#), [ref2](#), [ref3](#)

**pharmaceutical industry** *see* **Big Pharma**

**phthalates** [ref1](#)

**Plato's Allegory of the Cave** [ref1](#), [ref2](#)

**pneuma** [ref1](#)

**police**

Black Lives Matter (BLM) [ref1](#)

brutality [ref1](#)

citizen's arrests [ref1](#), [ref2](#)

common law arrests [ref1](#), [ref2](#)

Common Purpose [ref1](#)  
defunding [ref1](#)  
lockdowns [ref1](#), [ref2](#)  
masks [ref1](#), [ref2](#), [ref3](#), [ref4](#)  
police-military state [ref1](#), [ref2](#), [ref3](#)  
psychopathic personality [ref1](#), [ref2](#), [ref3](#), [ref4](#)  
reframing [ref1](#)  
United States [ref1](#), [ref2](#), [ref3](#), [ref4](#)  
Wokeness [ref1](#)

**polio** [ref1](#)

**political correctness** [ref1](#), [ref2](#), [ref3](#), [ref4](#)

**political parties** [ref1](#), [ref2](#), [ref3](#), [ref4](#)

**political puppets** [ref1](#)

**pollution** [ref1](#), [ref2](#), [ref3](#)

**post-mortems/autopsies** [ref1](#)

**Postage Stamp Consensus** [ref1](#), [ref2](#)

**pre-emptive programming** [ref1](#)

**Problem-Reaction-Solution** [ref1](#), [ref2](#), [ref3](#), [ref4](#), [ref5](#), [ref6](#), [ref7](#), [ref8](#)

**Project for the New American Century** [ref1](#), [ref2](#), [ref3](#), [ref4](#)

**psychopathic personality** [ref1](#)

Archons [ref1](#)

heart energy [ref1](#)

lockdowns [ref1](#), [ref2](#), [ref3](#)

police [ref1](#), [ref2](#), [ref3](#), [ref4](#)

recruitment [ref1](#), [ref2](#)

vaccines [ref1](#)

wealth [ref1](#)

Wetiko [ref1](#), [ref2](#)

**Psyop (psychological operation), Covid as a** [ref1](#), [ref2](#), [ref3](#), [ref4](#),  
[ref5](#)

**Pushbackers** [ref1](#), [ref2](#), [ref3](#), [ref4](#)

**pyramid structure** [ref1](#), [ref2](#), [ref3](#), [ref4](#)



## Q

**QAnon Psyop** [ref1](#), [ref2](#), [ref3](#)

## R

**racism** *see also* **Black Lives**

Matter (BLM)

anti-racism industry [ref1](#)

class [ref1](#)

critical race theory [ref1](#)

culture [ref1](#)

intersectionality [ref1](#)

reverse racism [ref1](#)

white privilege [ref1](#), [ref2](#)

white supremacy [ref1](#), [ref2](#), [ref3](#), [ref4](#), [ref5](#)

Wokeness [ref1](#), [ref2](#), [ref3](#)

**radiation** [ref1](#), [ref2](#)

**randomness, illusion of** [ref1](#), [ref2](#), [ref3](#)

**reality** [ref1](#), [ref2](#), [ref3](#)

**reframing** [ref1](#), [ref2](#)

change agents [ref1](#), [ref2](#)

children [ref1](#)

climate change [ref1](#)

Common Purpose leadership programme [ref1](#), [ref2](#)

contradictory rules [ref1](#)

enforcers [ref1](#)

masks [ref1](#), [ref2](#)

NLP and the Delphi technique [ref1](#)

police [ref1](#)

Wetiko factor [ref1](#)

Wokeness [ref1](#), [ref2](#)

**religion** *see also* particular religions

alien invasions [ref1](#)

Archons [ref1](#), [ref2](#)  
consciousness [ref1](#), [ref2](#)  
control, system of [ref1](#), [ref2](#), [ref3](#)  
criticism, prohibition on [ref1](#)  
five senses [ref1](#)  
good and evil, war between [ref1](#)  
hidden non-human forces [ref1](#), [ref2](#)  
Sabbatians [ref1](#)  
save me syndrome [ref1](#)  
Wetiko [ref1](#)  
Wokeness [ref1](#)

**repetition and mind control** [ref1](#), [ref2](#), [ref3](#)  
**reporting/snitching, encouragement of** [ref1](#), [ref2](#)  
**Reptilians/Grey entities** [ref1](#)  
**rewiring the mind** [ref1](#)  
**Rivers, Thomas Milton** [ref1](#), [ref2](#)  
**Rockefeller family** [ref1](#), [ref2](#), [ref3](#), [ref4](#), [ref5](#), [ref6](#), [ref7](#), [ref8](#), [ref9](#)  
**Rockefeller Foundation documents** [ref1](#), [ref2](#), [ref3](#), [ref4](#)  
**Roman Empire** [ref1](#)  
**Rothschild family** [ref1](#), [ref2](#), [ref3](#), [ref4](#), [ref5](#), [ref6](#), [ref7](#), [ref8](#), [ref9](#)  
**RT-PCR tests** [ref1](#), [ref2](#), [ref3](#), [ref4](#), [ref5](#), [ref6](#), [ref7](#), [ref8](#)  
**Russia**  
    collusion inquiry in US [ref1](#)  
**Russian Revolution** [ref1](#), [ref2](#)  
Sabbatians [ref1](#)

## **S**

**Sabbatian-Frankism** [ref1](#), [ref2](#)  
    anti-Semitism [ref1](#), [ref2](#)  
    banking and finance [ref1](#), [ref2](#), [ref3](#)  
    China [ref1](#), [ref2](#)  
    Israel [ref1](#), [ref2](#), [ref3](#), [ref4](#), [ref5](#)

Judaism [ref1](#), [ref2](#), [ref3](#), [ref4](#), [ref5](#)  
Lucifer [ref1](#)  
media [ref1](#), [ref2](#)  
Nazis [ref1](#), [ref2](#)  
QAnon [ref1](#)  
Rothschilds [ref1](#), [ref2](#), [ref3](#), [ref4](#), [ref5](#), [ref6](#)  
Russia [ref1](#)  
Saudi Arabia [ref1](#)  
Silicon Valley [ref1](#)  
Sumer [ref1](#)  
United States [ref1](#), [ref2](#), [ref3](#)  
Wetiko factor [ref1](#)  
Wokeness [ref1](#), [ref2](#), [ref3](#)  
**SAGE (Scientific Advisory Group for Emergencies)** [ref1](#), [ref2](#), [ref3](#),  
[ref4](#)  
**SARS-1** [ref1](#)  
**SARs-CoV-2** [ref1](#), [ref2](#), [ref3](#), [ref4](#), [ref5](#), [ref6](#), [ref7](#), [ref8](#)  
**Satan/Satanism** [ref1](#), [ref2](#), [ref3](#), [ref4](#), [ref5](#), [ref6](#), [ref7](#)  
**satellites in low-orbit** [ref1](#)  
**Saudi Arabia** [ref1](#)  
**Save Me Syndrome** [ref1](#)  
**scapegoating** [ref1](#)  
**Schwab, Klaus** [ref1](#), [ref2](#), [ref3](#), [ref4](#), [ref5](#), [ref6](#), [ref7](#), [ref8](#), [ref9](#), [ref10](#),  
[ref11](#), [ref12](#)  
**science, manipulation of** [ref1](#)  
**self-identity** [ref1](#), [ref2](#), [ref3](#), [ref4](#)  
**self-respect, attacks on** [ref1](#)  
**September 11, 2001, terrorist attacks on United States** [ref1](#), [ref2](#),  
[ref3](#), [ref4](#)  
**77th Brigade of UK military** [ref1](#), [ref2](#), [ref3](#)  
**Silicon Valley/tech giants** [ref1](#), [ref2](#), [ref3](#), [ref4](#), [ref5](#), [ref6](#) *see also*  
**Facebook**

Israel [ref1](#)

Sabbatians [ref1](#)

technocracy [ref1](#)

Wetiko factor [ref1](#)

Wokeness [ref1](#)

**simulation hypothesis** [ref1](#), [ref2](#), [ref3](#), [ref4](#), [ref5](#)

**Smart Grid** [ref1](#), [ref2](#), [ref3](#)

artificial intelligence (AI) [ref1](#)

China [ref1](#), [ref2](#)

control centres [ref1](#)

the Field [ref1](#)

Great Reset [ref1](#)

Human 2.0 [ref1](#), [ref2](#)

Israel [ref1](#), [ref2](#)

vaccines [ref1](#)

Wetiko factor [ref1](#)

**social disapproval** [ref1](#)

**social distancing and isolation** [ref1](#), [ref2](#), [ref3](#)

abusive relationships [ref1](#), [ref2](#)

children [ref1](#)

flats and apartments [ref1](#)

heart issues [ref1](#)

hugs [ref1](#)

Internet [ref1](#)

masks [ref1](#)

media [ref1](#)

older people [ref1](#), [ref2](#)

one-metre (three feet) rule [ref1](#)

rewiring the mind [ref1](#)

**simulation, universe as a** [ref1](#)

**SPI-B** [ref1](#)

substance abuse [ref1](#)

suicide and self-harm [ref1](#), [ref2](#), [ref3](#), [ref4](#), [ref5](#)

technology [ref1](#)

torture, as [ref1](#), [ref2](#)

two-metre (six feet) rule [ref1](#)

women [ref1](#)

**social justice** [ref1](#), [ref2](#), [ref3](#), [ref4](#)

**social media** *see also* **Facebook bans on alternative views** [ref1](#)

    censorship [ref1](#), [ref2](#), [ref3](#), [ref4](#), [ref5](#), [ref6](#)

    children [ref1](#)

    emotion [ref1](#)

    perception [ref1](#)

    private messages [ref1](#)

    Twitter [ref1](#), [ref2](#), [ref3](#), [ref4](#), [ref5](#), [ref6](#), [ref7](#)

    Wetiko factor [ref1](#)

    YouTube [ref1](#), [ref2](#), [ref3](#), [ref4](#), [ref5](#)

**Soros, George** [ref1](#), [ref2](#), [ref3](#), [ref4](#), [ref5](#), [ref6](#)

**Spain** [ref1](#)

**SPI-B (Scientific Pandemic Insights Group on Behaviours)** [ref1](#),  
[ref2](#), [ref3](#), [ref4](#)

**spider and the web** [ref1](#), [ref2](#), [ref3](#), [ref4](#)

**Starmer, Keir** [ref1](#)

**Statute Law** [ref1](#)

**Steiner, Rudolf** [ref1](#), [ref2](#), [ref3](#)

**Stockholm syndrome** [ref1](#)

**streptomycin** [ref1](#)

**suicide and self-harm** [ref1](#), [ref2](#), [ref3](#), [ref4](#), [ref5](#)

**Sumer** [ref1](#), [ref2](#)

**Sunstein, Cass** [ref1](#), [ref2](#), [ref3](#)

**swine flu (H1N1)** [ref1](#), [ref2](#), [ref3](#)

**synchronicity** [ref1](#)

**synthetic biology** [ref1](#), [ref2](#), [ref3](#), [ref4](#)

**synthetic meat** [ref1](#), [ref2](#)

## T

**technology** *see also* **artificial intelligence (AI); Internet;**

social media addiction [ref1](#), [ref2](#), [ref3](#), [ref4](#)

Archons [ref1](#), [ref2](#)

the cloud [ref1](#), [ref2](#), [ref3](#), [ref4](#), [ref5](#), [ref6](#), [ref7](#)

cyber-operations [ref1](#)

cyberwarfare [ref1](#)

radiation [ref1](#), [ref2](#)

social distancing and isolation [ref1](#)

technocracy [ref1](#)

**Tedros Adhanom Ghebreyesus** [ref1](#), [ref2](#), [ref3](#), [ref4](#), [ref5](#), [ref6](#), [ref7](#),  
[ref8](#), [ref9](#), [ref10](#), [ref11](#), [ref12](#), [ref13](#)

telepathy [ref1](#)

**Tenpenny, Sherri** [ref1](#)

**Tesla, Nikola** [ref1](#)

**testosterone levels, decrease in** [ref1](#)

**testing for Covid-19** [ref1](#), [ref2](#)

anal swab tests [ref1](#)

cancer [ref1](#)

China [ref1](#), [ref2](#), [ref3](#)

Corman-Drosten test [ref1](#), [ref2](#), [ref3](#), [ref4](#)

death certificates [ref1](#), [ref2](#)

fraudulent testing [ref1](#)

genetic material, amplification of [ref1](#)

Lateral Flow Device (LFD) [ref1](#)

PCR tests [ref1](#), [ref2](#), [ref3](#), [ref4](#), [ref5](#), [ref6](#), [ref7](#), [ref8](#)

vaccines [ref1](#), [ref2](#), [ref3](#)

**Thunberg, Greta** [ref1](#), [ref2](#), [ref3](#)

**Totalitarian Tiptoe** [ref1](#), [ref2](#), [ref3](#), [ref4](#)

**transgender persons**

activism [ref1](#)

artificial wombs [ref1](#)

censorship [ref1](#)  
    child abuse [ref1](#), [ref2](#)  
    Human 2.0 [ref1](#), [ref2](#), [ref3](#)  
    Wokeness [ref1](#), [ref2](#), [ref3](#), [ref4](#), [ref5](#)  
    women, deletion of rights and status of [ref1](#), [ref2](#)  
    young persons [ref1](#)

**travel restrictions** [ref1](#)

**Trudeau, Justin** [ref1](#), [ref2](#), [ref3](#)

**Trump, Donald** [ref1](#), [ref2](#), [ref3](#), [ref4](#), [ref5](#), [ref6](#), [ref7](#), [ref8](#), [ref9](#), [ref10](#),  
    [ref11](#)

**Twitter** [ref1](#), [ref2](#), [ref3](#), [ref4](#), [ref5](#), [ref6](#), [ref7](#)

## **U**

**UKColumn** [ref1](#), [ref2](#)

**United Nations (UN)** [ref1](#), [ref2](#), [ref3](#), [ref4](#), [ref5](#) *see also* **Agenda  
21/Agenda 2030 (UN)**

**United States** [ref1](#), [ref2](#)

    American Revolution [ref1](#)

    borders [ref1](#), [ref2](#)

    Capitol Hill riot [ref1](#), [ref2](#)

    children [ref1](#)

    China [ref1](#), [ref2](#)

    CIA [ref1](#), [ref2](#)

    Daily Pass tracking system [ref1](#)

    demographics by immigration, changes in [ref1](#)

    Democrats [ref1](#), [ref2](#), [ref3](#), [ref4](#), [ref5](#), [ref6](#), [ref7](#)

    election fraud [ref1](#)

    far-right domestic terrorists, pushbackers as [ref1](#)

    Federal Reserve [ref1](#)

    flu/respiratory diseases statistics [ref1](#)

    Global Cult [ref1](#), [ref2](#)

    hand sanitisers, FDA warnings on [ref1](#)

immigration, effects of illegal [ref1](#)  
impeachment [ref1](#)  
Israel [ref1](#), [ref2](#)  
Judaism [ref1](#), [ref2](#), [ref3](#)  
lockdown [ref1](#)  
masks [ref1](#)  
mass media [ref1](#), [ref2](#)  
nursing homes [ref1](#)  
Pentagon [ref1](#), [ref2](#), [ref3](#), [ref4](#)  
police [ref1](#), [ref2](#), [ref3](#), [ref4](#)  
pushbackers [ref1](#)  
Republicans [ref1](#), [ref2](#)  
borders [ref1](#), [ref2](#)  
Democrats [ref1](#), [ref2](#), [ref3](#), [ref4](#), [ref5](#)  
Russia, inquiry into collusion with [ref1](#)  
Sabbatians [ref1](#), [ref2](#), [ref3](#)  
September 11, 2001, terrorist attacks [ref1](#), [ref2](#), [ref3](#), [ref4](#)  
UFO sightings, release of information on [ref1](#)  
vaccines [ref1](#)  
white supremacy [ref1](#), [ref2](#), [ref3](#), [ref4](#)  
Woke Democrats [ref1](#), [ref2](#)

## **V**

vaccines [ref1](#), [ref2](#), [ref3](#)  
adverse reactions [ref1](#), [ref2](#), [ref3](#), [ref4](#), [ref5](#)  
Africa [ref1](#)  
anaphylactic shock [ref1](#), [ref2](#), [ref3](#), [ref4](#)  
animals [ref1](#), [ref2](#)  
anti-vax movement [ref1](#), [ref2](#), [ref3](#), [ref4](#), [ref5](#)  
AstraZeneca/Oxford [ref1](#), [ref2](#), [ref3](#), [ref4](#)  
autoimmune diseases, rise in [ref1](#), [ref2](#)  
Big Pharma [ref1](#), [ref2](#), [ref3](#), [ref4](#), [ref5](#), [ref6](#), [ref7](#), [ref8](#)



bioweapon, as real [ref1](#), [ref2](#)  
black and ethnic minority communities [ref1](#)  
blood clots [ref1](#), [ref2](#)  
Brain Computer Interface (BCI) [ref1](#)  
care homes, deaths in [ref1](#)  
censorship [ref1](#), [ref2](#), [ref3](#)  
chief medical officers and scientific advisers, financial interests of  
[ref1](#), [ref2](#)  
children [ref1](#), [ref2](#), [ref3](#), [ref4](#), [ref5](#), [ref6](#), [ref7](#), [ref8](#), [ref9](#), [ref10](#)  
China [ref1](#), [ref2](#)  
clinical trials [ref1](#), [ref2](#), [ref3](#), [ref4](#), [ref5](#), [ref6](#)  
compensation [ref1](#)  
compulsory vaccinations [ref1](#), [ref2](#), [ref3](#)  
computer programs [ref1](#)  
consciousness [ref1](#)  
cover-ups [ref1](#)  
creation before Covid [ref1](#)  
cytokine storm [ref1](#)  
deaths and illnesses caused by vaccines [ref1](#), [ref2](#), [ref3](#), [ref4](#), [ref5](#)  
definition [ref1](#)  
developing countries [ref1](#)  
digital tattoos [ref1](#)  
DNA-manipulation [ref1](#), [ref2](#), [ref3](#), [ref4](#), [ref5](#), [ref6](#), [ref7](#), [ref8](#), [ref9](#),  
[ref10](#)  
emergency approval [ref1](#), [ref2](#), [ref3](#), [ref4](#), [ref5](#)  
female infertility [ref1](#)  
funding [ref1](#)  
genetic suicide [ref1](#)  
Global Cult [ref1](#)  
heart chakras [ref1](#)  
hesitancy [ref1](#)  
Human 2.0 [ref1](#), [ref2](#), [ref3](#), [ref4](#)  
immunity from prosecution [ref1](#), [ref2](#), [ref3](#)

implantable technology [ref1](#)  
Israel [ref1](#)  
Johnson & Johnson [ref1](#), [ref2](#), [ref3](#), [ref4](#)  
lockdowns [ref1](#)  
long-term effects [ref1](#)  
mainstream media [ref1](#), [ref2](#), [ref3](#), [ref4](#), [ref5](#)  
masks [ref1](#), [ref2](#), [ref3](#), [ref4](#), [ref5](#)  
Medicines and Healthcare products Regulatory Agency (MHRA)  
[ref1](#), [ref2](#)  
messaging [ref1](#)  
Moderna [ref1](#), [ref2](#), [ref3](#), [ref4](#), [ref5](#), [ref6](#)  
mRNA vaccines [ref1](#), [ref2](#), [ref3](#), [ref4](#), [ref5](#), [ref6](#), [ref7](#), [ref8](#), [ref9](#)  
nanotechnology [ref1](#), [ref2](#)  
NHS [ref1](#), [ref2](#), [ref3](#), [ref4](#), [ref5](#)  
older people [ref1](#), [ref2](#)  
operating system [ref1](#)  
passports [ref1](#), [ref2](#), [ref3](#), [ref4](#)  
Pfizer/BioNTech [ref1](#), [ref2](#), [ref3](#), [ref4](#), [ref5](#), [ref6](#), [ref7](#)  
polyethylene glycol [ref1](#)  
pregnant women [ref1](#)  
psychopathic personality [ref1](#)  
races, targeting different [ref1](#)  
reverse transcription [ref1](#)  
Smart Grid [ref1](#)  
social distancing [ref1](#)  
social media [ref1](#)  
sterility [ref1](#)  
synthetic material, introduction of [ref1](#)  
tests [ref1](#), [ref2](#), [ref3](#)  
travel restrictions [ref1](#)  
**variants** [ref1](#), [ref2](#)  
**viruses, existence of** [ref1](#)  
whistle-blowing [ref1](#)

WHO [ref1](#), [ref2](#), [ref3](#), [ref4](#)  
Wokeness [ref1](#)  
working, vaccine as [ref1](#)  
young people [ref1](#)  
**Vallance, Patrick** [ref1](#), [ref2](#), [ref3](#), [ref4](#), [ref5](#), [ref6](#), [ref7](#), [ref8](#), [ref9](#)  
variants [ref1](#), [ref2](#), [ref3](#)  
vegans [ref1](#)  
ventilators [ref1](#), [ref2](#)  
virology [ref1](#), [ref2](#)  
virtual reality [ref1](#), [ref2](#), [ref3](#)  
viruses, existence of [ref1](#)  
visual reality [ref1](#), [ref2](#)  
vitamin D [ref1](#), [ref2](#)  
von Braun, Wernher [ref1](#), [ref2](#)

## **W**

war-zone hospital myths [ref1](#)  
waveforms [ref1](#), [ref2](#)  
wealth [ref1](#), [ref2](#), [ref3](#), [ref4](#), [ref5](#), [ref6](#), [ref7](#), [ref8](#), [ref9](#) [ref10](#), [ref11](#)  
wet market conspiracy [ref1](#)  
**Wetiko factor** [ref1](#)  
    alcoholism and drug addiction [ref1](#)  
    anti-human, why Global Cult is [ref1](#)  
    Archons [ref1](#), [ref2](#), [ref3](#), [ref4](#)  
    artificial intelligence (AI) [ref1](#)  
    Big Pharma [ref1](#), [ref2](#)  
    children [ref1](#)  
    China [ref1](#)  
    consciousness [ref1](#), [ref2](#)  
    education [ref1](#)  
    Facebook [ref1](#)

fear [ref1](#), [ref2](#)  
frequency [ref1](#), [ref2](#)  
Gates [ref1](#), [ref2](#)  
Global Cult [ref1](#), [ref2](#)  
heart [ref1](#), [ref2](#)  
lockdowns [ref1](#)  
masks [ref1](#)  
Native American concept [ref1](#)  
psychopathic personality [ref1](#), [ref2](#)  
reframing/retraining programmes [ref1](#)  
religion [ref1](#)  
Silicon Valley [ref1](#)  
Smart Grid [ref1](#)  
smartphone addiction [ref1](#), [ref2](#)  
social media [ref1](#)  
war [ref1](#), [ref2](#)  
WHO [ref1](#)  
Wokeness [ref1](#), [ref2](#), [ref3](#)  
Yaldabaoth [ref1](#), [ref2](#), [ref3](#), [ref4](#)  
**whistle-blowing** [ref1](#), [ref2](#), [ref3](#), [ref4](#), [ref5](#), [ref6](#), [ref7](#)  
**white privilege** [ref1](#), [ref2](#)  
**white supremacy** [ref1](#), [ref2](#), [ref3](#), [ref4](#), [ref5](#)  
**Whitty, Christopher** [ref1](#), [ref2](#), [ref3](#), [ref4](#), [ref5](#), [ref6](#), [ref7](#), [ref8](#), [ref9](#),  
[ref10](#)  
**'who benefits'** [ref1](#)  
**Wi-Fi** [ref1](#), [ref2](#), [ref3](#), [ref4](#)  
**Wikipedia** [ref1](#), [ref2](#)  
**Wojcicki, Susan** [ref1](#), [ref2](#), [ref3](#), [ref4](#), [ref5](#), [ref6](#), [ref7](#)  
**Wokeness**  
Antifa [ref1](#), [ref2](#), [ref3](#), [ref4](#)  
anti-Semitism [ref1](#)  
billionaire social justice warriors [ref1](#), [ref2](#), [ref3](#)

Capitol Hill riot [ref1](#), [ref2](#)  
censorship [ref1](#)  
Christianity [ref1](#)  
climate change hoax [ref1](#), [ref2](#)  
culture [ref1](#)  
education, control of [ref1](#)  
emotion [ref1](#)  
facts [ref1](#)  
fascism [ref1](#), [ref2](#), [ref3](#)  
Global Cult [ref1](#), [ref2](#), [ref3](#), [ref4](#)  
group-think [ref1](#)  
immigration [ref1](#)  
indigenous people, solidarity with [ref1](#)  
inversion [ref1](#), [ref2](#), [ref3](#)  
left, hijacking the [ref1](#), [ref2](#)  
Marxism [ref1](#), [ref2](#), [ref3](#)  
mind control [ref1](#)  
New Woke [ref1](#)  
Old Woke [ref1](#)  
Oneness [ref1](#)  
perceptual programming [ref1](#)  
    Phantom Self [ref1](#)  
police [ref1](#)  
defunding the [ref1](#)  
reframing [ref1](#)  
public institutions [ref1](#)  
Pushbackers [ref1](#), [ref2](#), [ref3](#)  
racism [ref1](#), [ref2](#), [ref3](#)  
reframing [ref1](#), [ref2](#)  
religion, as [ref1](#)  
Sabbatians [ref1](#), [ref2](#), [ref3](#)  
Silicon Valley [ref1](#)  
social justice [ref1](#), [ref2](#), [ref3](#), [ref4](#)

transgender [ref1](#), [ref2](#), [ref3](#), [ref4](#), [ref5](#)

United States [ref1](#), [ref2](#)

vaccines [ref1](#)

Wetiko factor [ref1](#), [ref2](#), [ref3](#)

young people [ref1](#), [ref2](#), [ref3](#)

women, deletion of rights and status of [ref1](#), [ref2](#)

World Economic Forum (WEF) [ref1](#), [ref2](#), [ref3](#), [ref4](#), [ref5](#), [ref6](#), [ref7](#),  
[ref8](#), [ref9](#)

World Health Organization (WHO) [ref1](#), [ref2](#), [ref3](#), [ref4](#), [ref5](#), [ref6](#),  
[ref7](#), [ref8](#), [ref9](#)

AIDs/HIV [ref1](#)

amplification cycles [ref1](#)

Big Pharma [ref1](#), [ref2](#), [ref3](#)

cooperation in health emergencies [ref1](#)

creation [ref1](#), [ref2](#)

fatality rate [ref1](#)

funding [ref1](#), [ref2](#), [ref3](#)

Gates [ref1](#)

Internet [ref1](#)

lockdown [ref1](#)

vaccines [ref1](#), [ref2](#), [ref3](#), [ref4](#)

Wetiko factor [ref1](#)

world number 1 (masses) [ref1](#), [ref2](#)

world number 2 [ref1](#)

Wuhan [ref1](#), [ref2](#), [ref3](#), [ref4](#), [ref5](#), [ref6](#), [ref7](#) [ref8](#)

## Y

Yaldabaoth [ref1](#), [ref2](#), [ref3](#), [ref4](#), [ref5](#), [ref6](#)

Yeadon, Michael [ref1](#), [ref2](#), [ref3](#), [ref4](#)

young people *see also* children addiction to technology [ref1](#)

Human 2.0 [ref1](#)

vaccines [ref1](#), [ref2](#)

Wokeness [ref1](#), [ref2](#), [ref3](#)

YouTube [ref1](#), [ref2](#), [ref3](#), [ref4](#), [ref5](#)

WHO 548

## **Z**

Zaks, Tal [ref1](#)

Zionism [ref1](#), [ref2](#), [ref3](#)

Zuckerberg, Mark [ref1](#), [ref2](#), [ref3](#), [ref4](#), [ref5](#), [ref6](#), [ref7](#), [ref8](#), [ref9](#),  
[ref10](#), [ref11](#), [ref12](#)

Zulus [ref1](#)

# **ICKONIC** **THE ALTERNATIVE**

Ickonic is something that has been a dream of mine for the last 5 years, growing up around alternative information I have always had a natural interest in what is going on in the World and what could I do to make it better.

Across the range of subjects and positions of influence occupied mainly by people who don't strive to make things better it's the Media that I have always found the most frustrating and fascinating. Mainly because if the Media did their Jobs properly then so much of the negative things happening in the World simply would not be able to happen, because they would be exposed within a heartbeat.

Free Press and the Opportunities that the internet could have given would mean that the Media are able to expose things like never before and hold people to account for their actions. As we all know there are 'Untouchables' that walk among us, people the Media simply won't touch, expose or investigate and that leads to the dark underworlds that infest the establishment the World over. Well I say enough, it's time for something different, a different kind of Media, where no one is off limits from exposing and investigating. All we're interested in at Ickonic is the truth of what is really going on in the World on whichever subject we're covering.

We hope you enjoy what we have created and take something away from the platform, we aim to deliver information that's informative and most importantly self-empowering, you're not a little person, you're part of something much bigger than that and its time we as a collective race began to understand that and look to the future as ours to take.

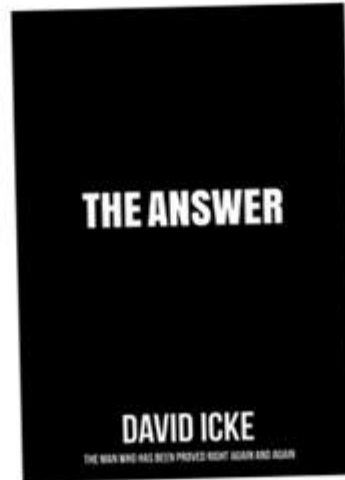
It's time...

Jaymie Icke - Founder Ickonic Alternative Media.

**SIGN UP NOW AT [ICKONIC.COM](http://ICKONIC.COM)**



DAVID ICKE  
**THE ANSWER**



We live in extraordinary times with billions bewildered and seeking answers for what is happening. David Icke, the man who has been proved right again and again, has spent 30 years uncovering the truth behind world affairs and in a stream of previous books he predicted current events.

The Answer will change your every perception of life and the world and set you free of the illusions that control human society. There is nothing more vital for our collective freedom than humanity becoming aware of what is in this book.

**Available now at [davidicke.com](http://davidicke.com).**

# THE TRIGGER

THE LIE THAT CHANGED THE WORLD  
- WHO REALLY DID IT AND WHY



DAVID ICKE



**EVERYTHING  
YOU NEED  
TO KNOW**

**BUT HAVE NEVER BEEN TOLD**

**DAVID ICKE**

**DAVIDICKE.COM**



**DAVID ICKE STORE**  
**LATEST NEWS ARTICLES**  
**DAVID ICKE VIDEOS**  
**WEEKLY DOT-CONNECTOR PODCASTS**  
**LIVE EVENTS**

[WWW.DAVIDICKE.COM](http://WWW.DAVIDICKE.COM)

THE LIFE STORY OF DAVID ICKE

# RENEGADE

THE FEATURE LENGTH FILM

/ˈren·iːgeɪd/

**noun**

A person who behaves in a rebelliously unconventional manner.



AVAILABLE NOW AT [DAVIDICKE.COM](http://DAVIDICKE.COM)

2 NEW BOOKS  
BY NEIL HAGUE

# ORION'S DOOR

SYMBOLS OF CONSCIOUSNESS & BLUEPRINTS OF CONTROL  
- THE STORY OF ORION'S INFLUENCE OVER HUMANITY

CUTTING EDGE VISIONARY ART  
& UNIQUE ILLUSTRATED BOOKS

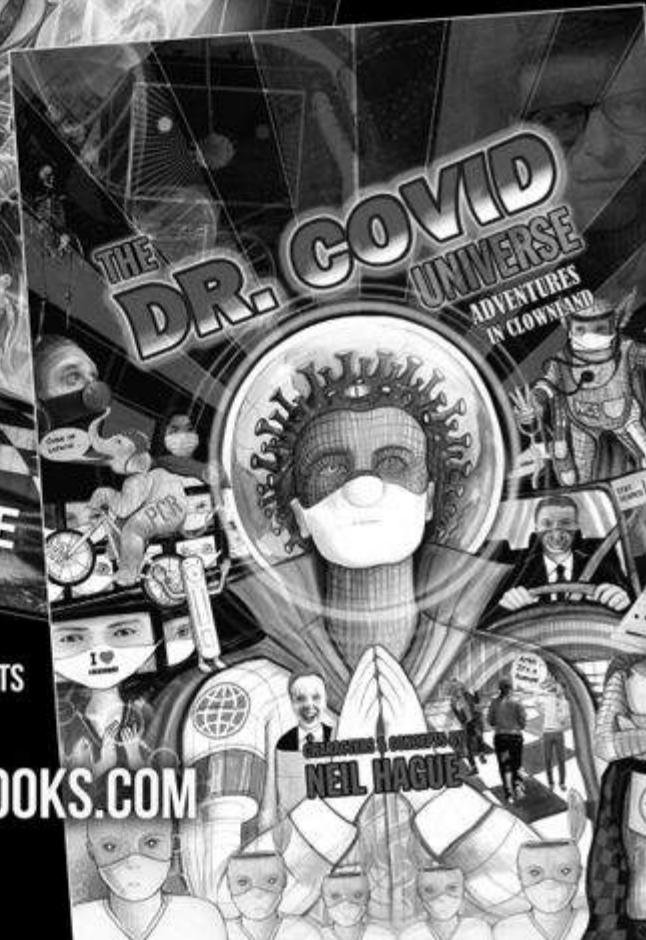
NEIL HAGUE

FOR  
BOOKS, PRINTS & T-SHIRTS

VISIT:

[NEILHAGUEBOOKS.COM](http://NEILHAGUEBOOKS.COM)

OR [NEILHAGUE.COM](http://NEILHAGUE.COM)



## **Before you go ...**

For more detail, background and evidence about the subjects in *Perceptions of a Renegade Mind* – and so much more – see my others books including *And The Truth Shall Set You Free; The Biggest Secret; Children of the Matrix; The David Icke Guide to the Global Conspiracy; Tales from the Time Loop; The Perception Deception; Remember Who You Are; Human Race Get Off Your Knees; Phantom Self; Everything You Need To Know But Have Never Been Told, The Trigger and The Answer.*

You can subscribe to the fantastic new Ickonic media platform where there are many hundreds of hours of cutting-edge information in videos, documentaries and series across a whole range of subjects which are added to every week. This includes my 90 minute breakdown of the week's news every Friday to explain *why* events are happening and to what end.