

ENDORSED BY



Book 2

Electrical Installations

SECOND EDITION

REVISED &
UPDATED
EDITION

LEVEL 3 ELECTROTECHNICAL APPRENTICESHIP (5357)
LEVEL 3 ELECTROTECHNICAL IN DWELLINGS
APPRENTICESHIP (5393)
LEVEL 3 ADVANCED TECHNICAL DIPLOMA (8202)
LEVEL 3 DIPLOMA (2365)
T LEVEL OCCUPATIONAL SPECIALISMS (352/353)

Peter Tanner

The City & Guilds textbook



Also available...

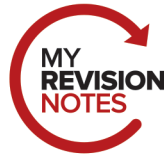

City & Guilds Level 3 Advanced Technical Diploma in Electrical Installation (8202-30)

Target success with this proven formula for effective, structured revision.

- ✓ Topic-by-topic planner
- ✓ Key content summaries
- ✓ Revision tasks
- ✓ Practice questions
- ✓ Tips and guidance

Our clear and concise approach to revision will help you learn, practise and apply your skills and understanding. Coverage of key content is combined with practical study tips and effective revision strategies to create a guide that can be relied on to build both knowledge and confidence.

Also available as a Boost eBook

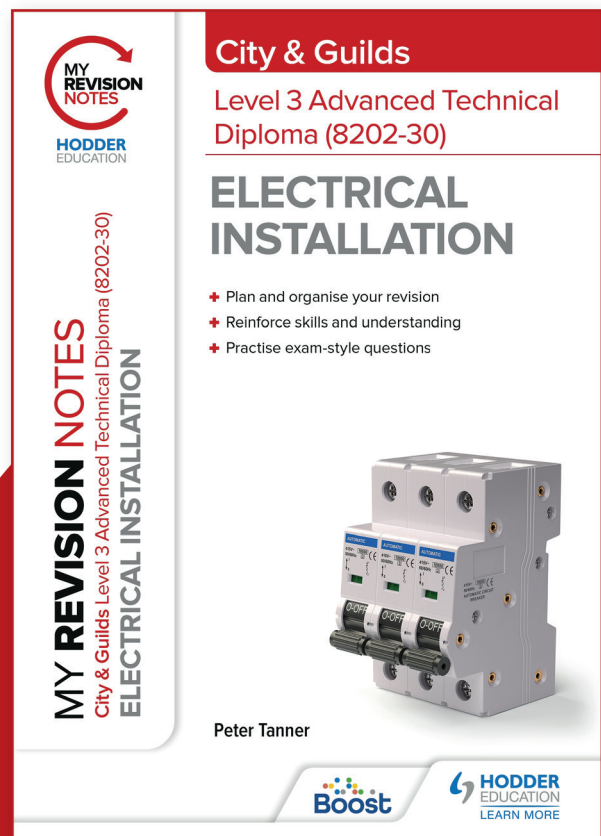

ISBN: 9781398327337

Find out more and order online at www.hoddereducation.co.uk/construction

Book 2

Electrical Installations

SECOND EDITION

LEVEL 3 ELECTROTECHNICAL
APPRENTICESHIP (5357)

LEVEL 3 ELECTROTECHNICAL IN DWELLINGS
APPRENTICESHIP (5393)

LEVEL 3 ADVANCED TECHNICAL DIPLOMA (8202)

LEVEL 3 DIPLOMA (2365)

T LEVEL OCCUPATIONAL SPECIALISMS (352/353)

| Peter Tanner

The City & Guilds textbook



HODDER
EDUCATION

AN HACHETTE UK COMPANY

Although every effort has been made to ensure that website addresses are correct at time of going to press, Hodder Education cannot be held responsible for the content of any website mentioned in this book. It is sometimes possible to find a relocated web page by typing in the address of the home page for a website in the URL window of your browser.

Hachette UK's policy is to use papers that are natural, renewable and recyclable products and made from wood grown in well-managed forests and other controlled sources. The logging and manufacturing processes are expected to conform to the environmental regulations of the country of origin.

Orders: please contact Hachette UK Distribution, Hely Hutchinson Centre, Milton Road, Didcot, Oxfordshire, OX11 7HH. Telephone: +44 (0)1235 827827. Email education@hachette.co.uk Lines are open from 9 a.m. to 5 p.m., Monday to Friday.

You can also order through our website: www.hoddereducation.co.uk

ISBN: 978 1 3983 6160 7

© The City & Guilds of London Institute, The Institution of Engineering and Technology, Peter Tanner and Hodder & Stoughton Limited 2022

Some text content in this book is published under licence from The City and Guilds of London Institute and The Institution of Engineering and Technology, London.

First published in 2019 by
Hodder Education,
An Hachette UK Company
Carmelite House
50 Victoria Embankment
London EC4Y 0DZ

www.hoddereducation.co.uk

Impression number 10 9 8 7 6 5 4 3 2 1

Year 2026 2025 2024 2023 2022

All rights reserved. Apart from any use permitted under UK copyright law, no part of this publication may be reproduced or transmitted in any form or by any means, electronic or mechanical, including photocopying and recording, or held within any information storage and retrieval system, without permission in writing from the publisher or under licence from the Copyright Licensing Agency Limited. Further details of such licences (for reprographic reproduction) may be obtained from the Copyright Licensing Agency Limited, www.cla.co.uk

Cover photo © iryna_l - stock.adobe.com

City & Guilds and the City & Guilds logo are trademarks of The City & Guilds of London Institute. City & Guilds logo © City & Guilds 2022

The IET logo is a registered trade mark of The Institution of Engineering and Technology.

Typeset in India.

Printed in Bosnia & Herzegovina

A catalogue record for this title is available from the British Library.



Contents

Acknowledgements	v
Picture credits	vi
About the author	vii
How to use this book	viii
1 Environmental technologies	1
Regulatory requirements relating to micro-renewable energy and water conservation technologies	2
Heat-producing micro-renewable energy technologies	4
Electricity-producing micro-renewable energy technologies	24
Micro-combined heat and power	44
Water conservation technologies	48
2 Advanced scientific principles	62
Power generation and supply	63
Transformers	76
Electrical circuits, systems and equipment	83
Calculate unknown values in AC circuits	90
Power factor and the power triangle	98
Power factor correction	102
Neutral current in three-phase and neutral supplies	105
Voltage and current in star- and delta-connected systems	108
Operating principles and applications of DC machines and AC motors	111
Operating principles of different electrical components	126
Application of electrical components in electrical systems	132
Electrical lighting systems	137
Principles and applications of electrical heating	152
3 BS 7671: 2018 (2022) requirements for electrical installations	166
What is BS 7671: 2018 (2022) and how to use it	167
Part 1: Scope, Object and Fundamental Principles	172
Part 2: Definitions	173
Part 3: Assessment of General Characteristics	173
Part 4: Protection for Safety	179
Part 5: Selection and Erection	202
Part 6: Inspection and Testing	216
Part 7: Special Installations or Locations	216
Part 8: Functional Requirements	219
Appendices	220
4 Working on site	226
Information	227
Planning the work on site	242
Site restoration	262
5 Electrical installation design	272
Supply characteristics	274
Circuits	277

Types of wiring system and methods of installation	282
Protective equipment	284
Circuit design procedure	288
Maximum demand and diversity	316
6 Inspection, testing and commissioning electrical installations	327
Preparing for inspection and testing	328
The inspection process	350
Testing	366
7 Electrical system fault diagnosis and rectification	400
Safety and regulatory requirements	401
Reporting and recording of fault diagnosis work	414
Fault diagnosis procedures	421
Fault rectification	440
Practice synoptic assessment	449
Appendix 1: Introduction to the electrotechnical qualifications	453
Appendix 2: Next steps	460
Glossary	471
Common acronyms	475
Formula sheet	476
Answers	479
Index	494

Acknowledgements

This book draws on several earlier books that were published by City & Guilds, and we acknowledge and thank the writers of those books:

- Howard Carey
- Paul Cook
- James L Deans
- Paul Harris
- Andrew Hay-Ellis
- Trevor Pickard.

We would also like to thank everyone who has contributed to City & Guilds photoshoots. In particular, thanks to: Jules Selmes and Adam Giles; Andrew Buckley; Andy Jeffery, Ben King and students from Oaklands College, St Albans; Jaylec Electrical; Andrew Hay-Ellis, James L Deans and the staff at Trade Skills 4 U, Crawley; Jordan Hay-Ellis, Terry White, Katherine Hodges and Claire Owen.

Permission to reproduce extracts from BS 7671:2018 +A2:2022 is granted by BSI Standards Limited (BSI) and the Institution of Engineering & Technology. No other use of this material is permitted.

Picture credits

Every effort has been made to trace and acknowledge ownership of copyright. The publishers will be glad to make suitable arrangements with any copyright holders whom it has not been possible to contact.

Photo page vii, Peter Tanner; Fig.1.7 © Paul Orr/Shutterstock.com; Fig.1.10a © Imran Khan/Alamy Stock Photo; Fig.1.10b © Bosch Thermotechnology Limited; Fig.1.10c © Inhabitant/Shutterstock.com; Fig.1.15 © Kensa Heat Pumps; Fig.1.21 © Winbjörk/Shutterstock.com; Fig.1.24 © Benjamin Haas/Shutterstock.com; Fig.1.25 © Flucas/stock.adobe.com; Fig.1.26 © Rafa Iruستا/stock.adobe.com; Fig.1.27 © GIPHOTOSTOCK/Science Photo Library; Fig.1.29 © Rudmer Zwerver/Shutterstock.com; Fig.1.39 © Peter Kunasz/Shutterstock.com; Fig.2.3 © M. Niebuhr/Shutterstock.com; Fig.2.5 © Gail Johnson/Shutterstock.com; Fig.2.6 © Ralf Gosch/Shutterstock.com; Fig.2.23 City & Guilds; Fig.2.57 © Staco Energy Products Co.; Figs 2.88, 2.90, 2.92, 2.96 and 2.106 City & Guilds; Fig.2.111 © Piotr Wardynski/Shutterstock.com; Fig.2.112 © ZayacSK/Shutterstock.com; Fig.2.113 © Picsfive/Shutterstock.com; Fig.2.114 © demarcomedia/Shutterstock.com; Fig.2.115 Emily Cooper; Fig.2.118 (left) © Vent-Axia Ltd; Fig.2.119 © Alexandr Mitiuc/stock.adobe.com; Fig.2.120 © Zakhar Marunov/stock.adobe.com; Fig.2.123 © sspopov/Shutterstock.com; Fig.2.126 City & Guilds; Fig.2.131 © Olivier Le Moal/stock.adobe.com; Fig.2.133 © ericlefrancais/Shutterstock.com; Fig.2.134 © Kunal Mehta/Shutterstock.com; Fig.2.135 © Arrow/stock.adobe.com; Fig.3.1 IET; Fig.3.11 © Hxdyl/stock.adobe.com; Figs 3.11, 3.13 and 3.16 City & Guilds; Fig.3.22 © Wolfilser/stock.adobe.com; Figs 4.2, 4.3 and 4.10 City & Guilds; Fig.4.11 © 2018 Screwfix Direct Limited; Fig.4.12 © Axminster Power Tool Centre; Fig.4.13 City & Guilds; Fig.4.14 © PhotoHouse/Shutterstock.com; Figs 4.15 and 4.16 City & Guilds; Fig.4.17 © Coolkengzz/stock.adobe.com; Fig.4.18 © Gajus/Shutterstock.com; Fig.4.19 © Bostik UK; Fig.5.15 © Kirk Fisher/stock.adobe.com; Fig.5.16 © Vladdeep/stock.adobe.com; Figs 6.2 and 6.3 © test-meter.co.uk; Figs 6.4 and 6.5 City & Guilds; Fig.6.6 IET; Figs 6.8–6.12 IET; Figs.6.18–6.22 © Kewtech; Fig.6.23 © Health & Safety Executive (HSE); Fig.6.24 © courtesy of Megger; Fig.6.39 © Martindale Electric Co Ltd; Fig.7.1 © Auremar/stock.adobe.com; Fig.7.3 © Health & Safety Executive (HSE); Fig.7.4 © PBWPIX/Alamy Stock Photo; Fig.7.5 IET; Fig.7.6 © Pro2audio/stock.adobe.com; Fig.7.7 City & Guilds; Fig.7.8 © Audrius Merfeldas/123RF; Fig.7.9 © zentilia/Shutterstock.com; Fig.7.10 City & Guilds; Fig.7.11 © Piamphoto/stock.adobe.com; Fig.7.12 (left) © Angelika Smile/stock.adobe.com, (right) © Denboma/stock.adobe.com; Fig.7.13 City & Guilds; Fig.7.14 © Makaule/stock.adobe.com; Fig.7.15 City & Guilds; Fig.7.16 © courtesy of Megger; Fig.7.17 © 1981 Rustic Studio/stock.adobe.com; photos pages 456–8 City & Guilds; photo page 460 © Joint Industry Board.

About the author

I started in the electrotechnical industry while still at school, chasing walls for my brother-in-law for a bit of pocket money. This taught me quickly that if I took a career as an electrician I needed to progress as fast as I could.

Jobs in the industry were few and far between when I left school so, after a spell in the armed forces, I gained a place as a sponsored trainee on the Construction Industry Training Board (CITB) training scheme. I attended block release at Guildford Technical College, where the CITB would find me work experience with 'local' employers. My first and only work experience placement was with a computer installation company located over 20 miles away, so I had to cycle there every morning, but I was desperate to learn and enjoyed my work.

Computer installations were very different in those days. Computers filled large rooms and needed massive armoured supply cables, so the range of work I experienced was vast – from data cabling to all types of containment systems and low-voltage systems.

In the second year of my apprenticeship I found employment with a company where most of my work centred around the London area. The work was varied, from lift systems in well-known high-rise buildings to lightning protection on the sides of even higher ones!

On completion of my apprenticeship I worked for a short time as an intruder alarm installer, mainly in domestic dwellings – a role in which client relationships and handling information are very important.

Following this I began work with a company where I was involved in shop-fitting and restaurant and pub refurbishments. It wasn't long before I was managing jobs and gaining further qualifications through professional development. I was later seconded to the Property Services Agency, designing major installations within some of the best-known buildings in the UK.

A career-changing accident took me into teaching, where I truly found the rewards the industry has to offer. Seeing young trainees maturing into qualified electricians is a highly gratifying experience. I often see many of my old trainees when they attend further training and updated courses. Following their successes makes it all worthwhile.

I have worked with City & Guilds for over 25 years and represented them on a variety of industry committees, such as JPEL/64, which is responsible for the production of **BS 7671**. I am passionate about using my extensive experience to maintain the high standards the industry expects.



Peter Tanner

May 2022

How to use this book

Throughout this book you will see the following features:

INDUSTRY TIPS and KEY FACTS are particularly useful pieces of advice that can assist you in your workplace or help you remember something important.

KEY FACT



The internal angles of a right-angled triangle always add up to 180° .

INDUSTRY TIP

Remember, when you are carrying out your practical tasks either in the workplace or your place of learning, everyone, including you, is responsible for safety.

KEY TERM

SI units: The units of measurement adopted for international use by the *Système International d'Unités*.

KEY TERMS in bold purple in the text are explained in the margin to aid your understanding. (They are also explained in the Glossary at the back of the book.)

HEALTH AND SAFETY

An ammeter has a very low internal resistance and must never be connected across the supply.

HEALTH AND SAFETY boxes flag important points to keep yourself, colleagues and clients safe in the workplace. They also link to sections in the health and safety chapter in Book 1 for you to recap learning.

ACTIVITY



A wall measures 6 cm on a 1:50 scale drawing. What is the true length of the wall?

ACTIVITIES help to test your understanding and learn from your colleagues' experiences.

VALUES AND BEHAVIOURS



Remember to consider how any work might disrupt the client and make sure you communicate this clearly before commencing work.

VALUES AND BEHAVIOURS boxes provide hints and tips on good practice in the workplace.

IMPROVE YOUR MATHS items combine improving your understanding of electrical installations with practising or improving your maths skills.



IMPROVE YOUR ENGLISH items combine improving your understanding of electrical installations with practising or improving your English skills.



At the end of each chapter there are some TEST YOUR KNOWLEDGE questions and PRACTICAL TASKS. These are designed to identify any areas where you might need further training or revision. Answers to the questions are at the back of the book.

ENVIRONMENTAL TECHNOLOGIES

INTRODUCTION

A large number of scientific studies show that climate change is causing more frequent and more extreme weather events around our planet and CO₂ emissions are a clear contributor towards this.

The use of energy storage and generating systems, as well as renewable technologies, will help to minimise climate change or its effects by reducing emissions.

The construction industry is already going some way to reduce emissions but needs to further promote and utilise these technologies in buildings.

Much of the decline in harmful emissions is due to new technologies used in building materials, insulation and renewable energy sources. When working in the electrotechnical sector, you are very likely to come across these technologies. This chapter is intended to explain how they work.

HOW THIS CHAPTER IS ORGANISED

This chapter is divided up into four sections, each one detailing a type of environmental technology system.

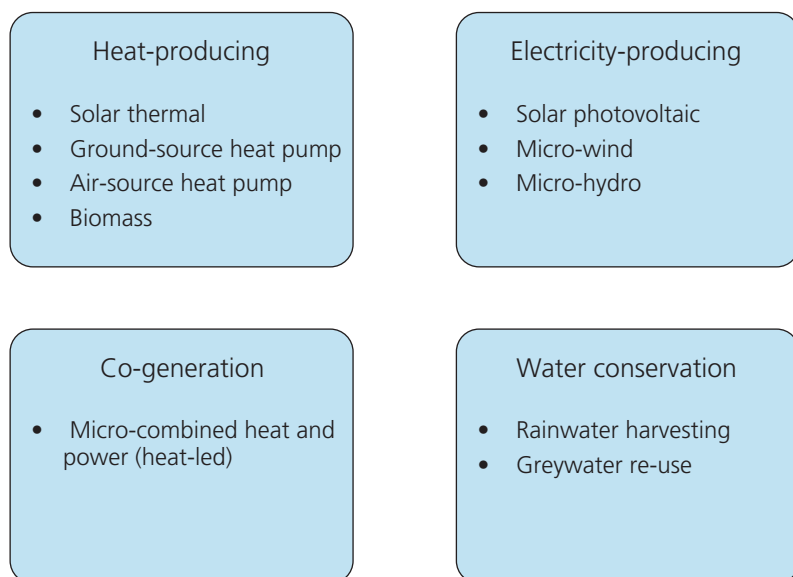

INDUSTRY TIP

The Office for National Statistics' website updates figures on CO₂ emissions every year. Visit their website to obtain the most current statistics.

▲ Figure 1.1 The environmental technology systems covered in this chapter

This approach will help you to understand the working principles of each system and how they impact on the installation requirements and the regulatory requirements. The advantages and disadvantages of each technology system are also described.

Note that, for those studying the **2365** Level 3 Diploma in Electrical Installations (Building and Structures) course, you will be formally assessed on your knowledge of environmental technologies as part of the **2365** certification.

For those studying:

- **5357** Electrical Qualification (installation or maintenance) (Apprenticeship)
- **8202** Level 3 Advanced Technical Diploma in Electrical Installation
- **8710-353** Electrotechnical Engineering Specialism

you will not be formally assessed, but this chapter offers useful information because, in the future, you may be expected to install or advise on environmental technologies.

For those studying 8710 T Level Technical Qualification in Building Services Engineering for Construction, this chapter will help with the core unit content (350), especially 5.10 within Outcome 5.

▼ Table 1.1 Chapter 1 assessment criteria coverage

Topic	5357	2365	8202	5393-104/004
Regulatory requirements relating to micro-renewable energy and water conservation technologies		3.1; 3.2		
Heat-producing micro-renewable energy technologies		1.1; 2.1; 2.3; 2.4; 2.5; 3.1; 3.2; 4.1; 4.2		
Electricity-producing micro-renewable energy technologies		1.2; 2.2; 2.6; 2.7; 3.1; 3.2; 4.1; 4.2		4.4; 7.3
Micro-combined heat and power		1.3; 2.8; 3.1; 3.2; 4.1; 4.2		
Water conservation technologies		1.4; 2.9; 3.1; 3.2; 4.1; 4.2		

T Level mapping grids are available on the Hodder Education website. These map the book to the occupational specialisms: 8710-353 (Electrical Engineering) and 8710-352 (Electrical and Electronic Equipment).

REGULATORY REQUIREMENTS RELATING TO MICRO-RENEWABLE ENERGY AND WATER CONSERVATION TECHNOLOGIES

It is important to have knowledge of the planning requirements and building regulations for each technology. This section:

- explains the terminology used
- provides insight into the workings of both the planning requirements and building regulations
- explains the differences in planning regulations across different regions of the UK.

Planning and permitted development

In general, under the Town and Country Planning Act 1990, before any building work that increases the size of a building is carried out, a planning application must be submitted to the local authority. A certain amount of building work is, however, allowed without the need for a planning application. This is known as **permitted development**.

Permitted development usually comes with criteria that must be met. When building an extension, for example, it may be possible to do so under permitted development, if the extension is under a certain size, is a certain distance away from the boundary of the property and is not at the front of the property. If the extension does not meet these criteria, then a full planning application must be made.

Permitted development is intended to ease the burden placed on local authorities and to smooth the process for the builder or installer. Permitted development exists for renewable technologies, and this chapter outlines the situations where it applies.

Building Regulations

The Climate Change and Sustainable Energy Act 2006 brought **microgeneration** under the requirements of the Building Regulations.

Even if a planning application is not required, because the installation meets the criteria for permitted development, there is still a requirement to comply with the relevant Building Regulations. Local Authority Building Control (LABC) is the body responsible for checking that Building Regulations have been met. The person carrying out the building work is responsible for ensuring that approval is obtained.

Building Regulations are statutory instruments that seek to ensure that the policies and requirements of the relevant legislation are complied with. The Building Regulations themselves are rather brief and, in England, are currently divided into 18 sections, each of which is accompanied by an Approved Document. The Approved Documents are non-statutory and give guidelines on how to comply with the statutory requirements.

The 18 parts of the Building Regulations in England are:

- Part A Structure
- Part B Fire safety
- Part C Site preparation and resistance to contaminants and moisture
- Part D Toxic substances
- Part E Resistance to the passage of sound
- Part F Ventilation
- Part G Sanitation, hot-water safety and water efficiency
- Part H Drainage and waste disposal
- Part J Combustion appliances and fuel-storage systems
- Part K Protection from falling, collision and impact
- Part L Conservation of fuel and power
- Part M Access to and use of buildings
- Part O Overheating
- Part P Electrical safety

KEY TERMS

Permitted development: Allows certain projects or building work to be carried out without the need for planning permission.

Microgeneration: The small-scale generation of heat or electric power by individuals, small businesses and communities to meet their own needs, as alternatives or in addition to traditional, centralised, grid-connected power, such as power stations.

INDUSTRY TIP

For more information on what is allowed as permitted development in a typical domestic dwelling, search for the planning portal (England and Wales) or Planning Portal NI (Northern Ireland) or ePlanning Scotland.

INDUSTRY TIP

You can research the Climate Change and Sustainable Energy Act 2006.

- Part Q Security in dwellings
- Part R High-speed electronic communications networks
- Part S Infrastructure for charging electric vehicles
- Document 7 Materials and workmanship.

Compliance with Building Regulations is required when installing renewable technologies. Not all of the Building Regulations will be applicable, however, and different technologies will have to comply with different Building Regulations. The Building Regulations applicable to each technology are indicated in this chapter.

HEAT-PRODUCING MICRO-RENEWABLE ENERGY TECHNOLOGIES

Some technologies produce heat using natural energy sources, such as the Sun or energy from the ground, as an alternative to burning gas or oil or using electricity.

Solar thermal (hot-water) systems

A solar thermal hot-water system uses solar radiation to heat water, directly or indirectly.

Working principles

The key components of a solar thermal hot-water system are:

- a solar thermal collector
- a differential temperature controller
- a circulating pump
- a hot-water storage cylinder
- an auxiliary heat source.

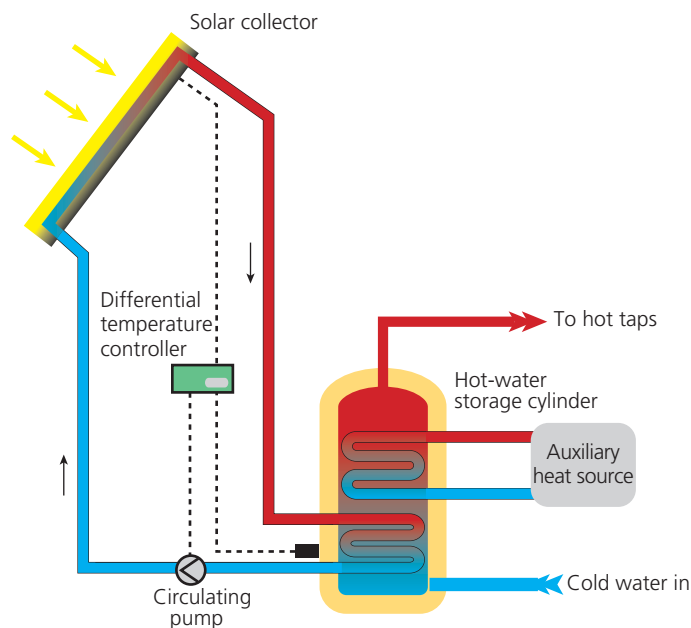

▲ Figure 1.2 Solar thermal hot-water system components

ACTIVITY
What would be an auxiliary heat source from the diagram shown in Figure 1.2?

Solar thermal collector

A solar thermal collector is designed to collect heat by absorbing heat radiation from the Sun. The energy from the Sun heats the heat-transfer fluid contained in the system. There are two types of solar thermal collector:

- flat-plate collectors
- evacuated-tube collectors.

Flat-plate collectors are less efficient but cheaper than evacuated-tube collectors. With a flat-plate collector, the heat-transfer fluid circulates through the collectors and is directly heated by the Sun. The collectors need to be well insulated to avoid heat loss.

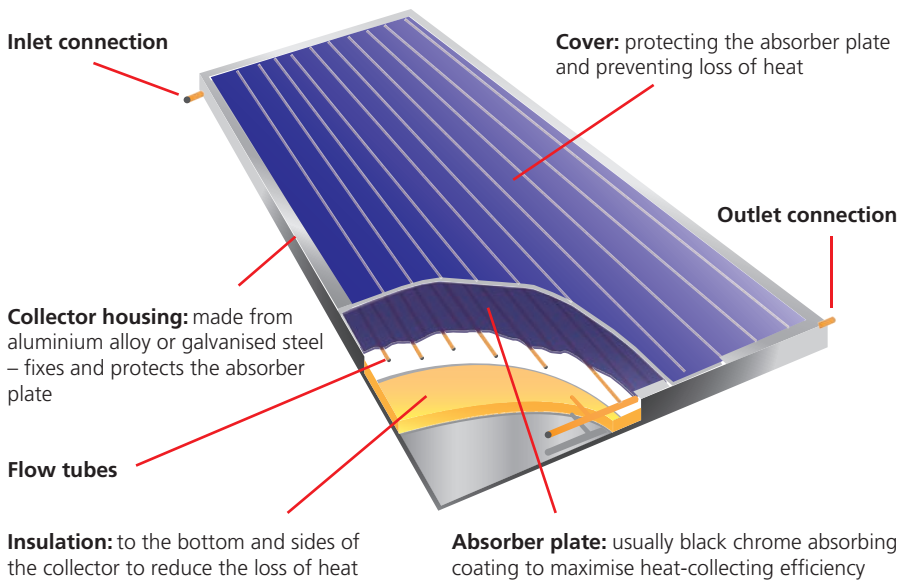

▲ Figure 1.3 Cutaway diagram of a flat-plate collector

Evacuated-tube collectors are more efficient but more expensive than flat-plate collectors.

An evacuated-tube collector consists of a specially coated, pressure-resistant, double-walled glass tube. The air is evacuated from the glass tube to aid the transfer of heat from the Sun to a heat tube that is housed within the glass tube. The heat tube contains a temperature-sensitive medium, such as methanol, that, when heated, vaporises. The warmed gas rises within the glass tube. A solar collector will contain several evacuated tubes in contact with a copper header tube that is part of the solar heating circuit. The heat tube is in contact with the header tube. The heat from the methanol vapour in the heat tubes is transferred by conduction to the heat-transfer fluid flowing through the solar heating circuit. This process cools the methanol vapour, which condenses and runs back down to the bottom of the heat tubes, ready for the process to start again. The collector must be mounted at a suitable angle to allow the vapour to rise and the condensed liquid to flow back down the heat tubes.

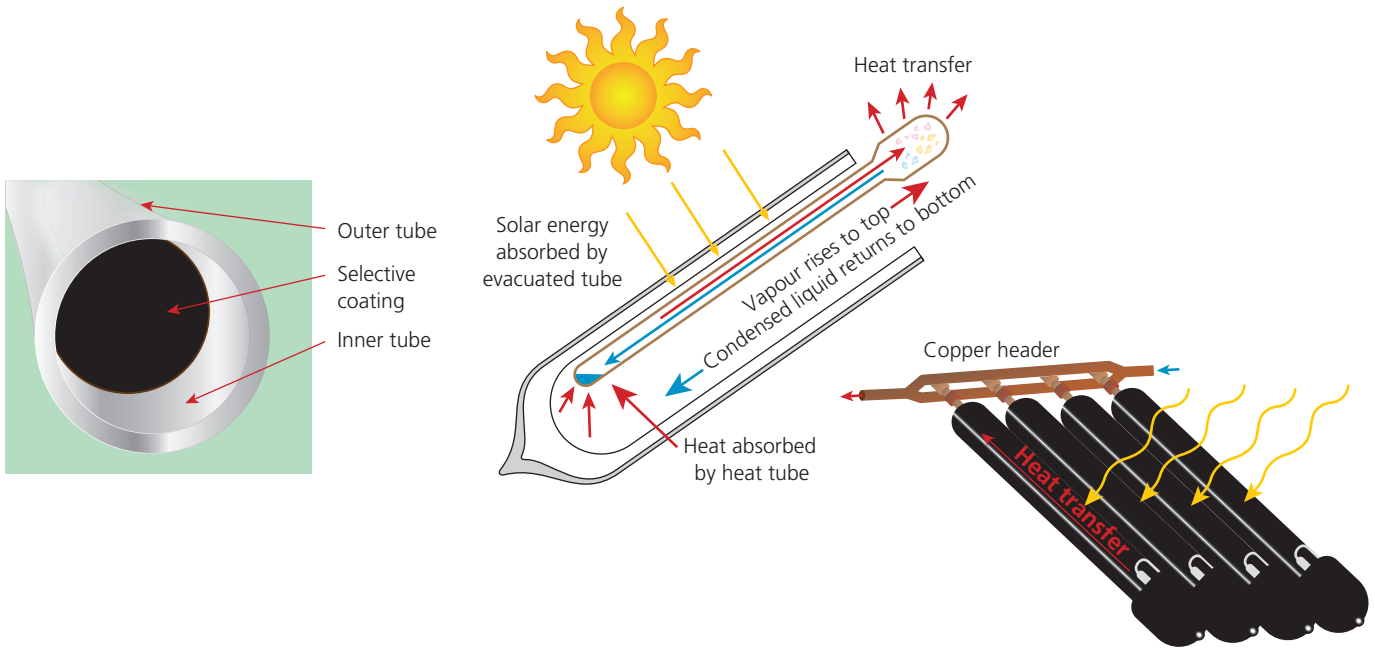

▲ Figure 1.4 Evacuated-tube collector

Differential temperature controller

The differential temperature controller (DTC) has sensors connected to the solar collector (high level) and the hot-water storage system (low level). It monitors the temperatures at the two points. The DTC turns the circulating pump on when there is enough solar energy available and there is a demand for water to be heated. Once the stored water reaches the required temperature, the DTC shuts off the circulating pump.

Circulating pump

The circulating pump is controlled by the DTC and circulates the system's heat-transfer fluid around the solar hot-water circuit. The circuit is a closed loop between the solar collector and the hot-water storage tank. The heat-transfer fluid is normally water-based but, depending on the system type, usually also contains antifreeze (glycol) so that at night, or in periods of low temperatures, it does not freeze in the collector.

Hot-water storage cylinder

The hot-water storage cylinder enables the transfer of heat from the solar collector circuit to the stored water. Several different types of cylinder or cylinder arrangement are possible.

Twin-coil cylinder

With this type of cylinder, the lower coil is the solar heating circuit and the upper coil is the auxiliary heating circuit. Cold water enters at the base of the cylinder and is heated by the solar heating coil. If the solar heating circuit cannot meet the required demand, then the boiler will provide heat through the upper coil. Hot water is drawn off, by the taps, from the top of the cylinder.

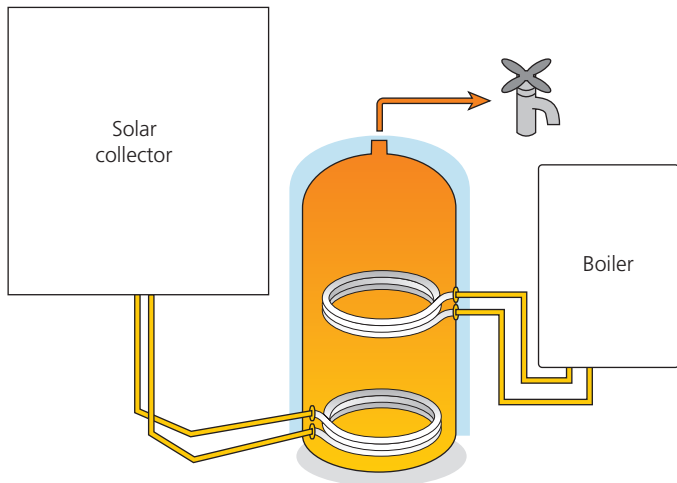

▲ Figure 1.5 Twin-coil cylinder

Alternatives

An alternative arrangement is to use one cylinder as a solar preheat cylinder, the output of which feeds a hot-water cylinder. The auxiliary heating circuit is connected to the second cylinder.

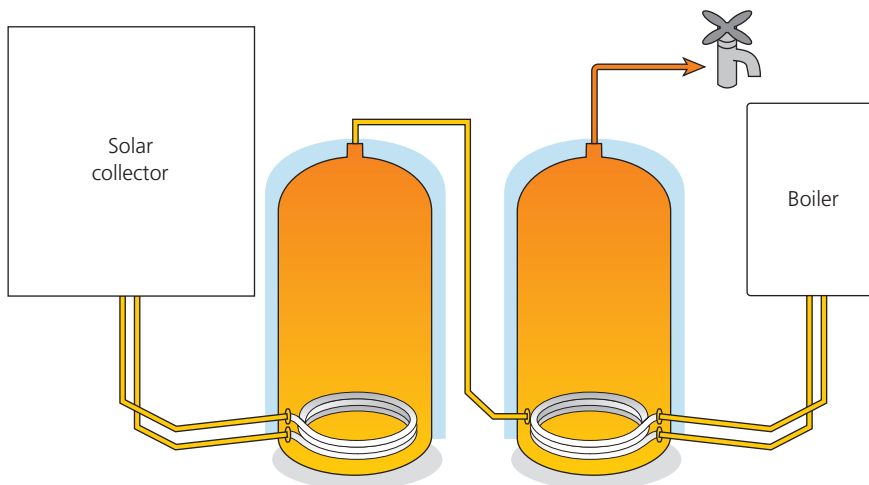

▲ Figure 1.6 Using two separate cylinders

The two arrangements that have been described are indirect systems, with the solar heating circuit forming a closed loop.

Direct system

A direct system is an alternative to an indirect system. In direct systems, the domestic hot water that is stored in the cylinder is directly circulated through the solar collector and is the same water that is drawn off at the taps. Owing to this fact, antifreeze (glycol) cannot be used in the system, so it is important to use freeze-tolerant collectors.

Auxiliary heat source

In the UK there will be times when there is insufficient solar energy available to provide adequate hot water. On these occasions an auxiliary heat source will be

required. Where the premises have space heating systems installed, the auxiliary heat source is usually this boiler. Where no suitable boiler exists, the auxiliary heat source will be an electric immersion heater.

Location and building requirements

The following factors should be considered when deciding whether or not a solar thermal hot-water system is suitable for particular premises.

The orientation of the solar collectors

The optimum direction for the solar collectors to face is due south. However, as the Sun rises in the east and sets in the west, any location with a roof facing east, south or west is suitable for mounting a solar thermal system, although the efficiency of the system will be reduced for any system not facing due south.

The tilt of the solar collectors

During the year, the maximum elevation or height of the Sun, relative to the horizon, changes. It is lowest in December and highest in June. Ideally, solar collectors should always be perpendicular to the path of the Sun's rays. As it is generally not practical to change the tilt angle of a solar collector, a compromise angle has to be used. In the UK, the angle is 35°; however, the collectors will work, but less efficiently, from vertical through to horizontal.

Shading of the solar collectors

Any structure, tree, chimney, aerial or other object that stands between the collector and the Sun will block the Sun's energy. The Sun shines for a limited time and any reduction in the amount of heat energy reaching the collector will reduce the collector's ability to provide hot water to meet the demand.

▼ Table 1.2 Degree of shading of solar collectors

Shading	% of sky blocked by obstacles	Reduction in output
Heavy	> 80%	50%
Significant	> 60–80%	35%
Modest	> 20–60%	20%
None or very little	≤ 20%	No reduction

The suitability of the structure for mounting the solar collector

The structure has to be assessed as to its suitability for the chosen mounting system. Consideration needs to be given to the strength and condition of the structure and the suitability of fixings. The effect of wind must also be taken into account. The force exerted by the wind on the collectors, an upward force known as 'wind uplift', affects both the solar collector fixings and the fixings holding the roof members to the building structure.

In the case of roof-mounted systems on blocks of flats and other shared properties, the ownership of the structure on which the proposed system is to be installed must be considered.

The space needed to mount the collectors is dependent on the demand for hot water. The number of people occupying the premises determines the demand for hot water and, therefore, the number of collectors required, and the space needed to mount them.

Compatibility with the existing hot-water system

Solar thermal systems provide stored hot water rather than instantaneous hot water. Premises using under/over-sink water heaters and electric showers will not be suitable for the installation of a solar thermal hot-water system; neither will premises using a combination boiler to provide hot water, unless substantial changes are made to the hot-water system.

Planning permission

Permitted development applies where a solar thermal hot-water system is installed:

- on a dwelling house or block of flats
- on a building within the grounds of a dwelling house or block of flats
- as a stand-alone system in the grounds of a dwelling house or block of flats.

However, there are criteria to be met in every case.

The criteria that must be met for **building-mounted systems** are that:

- the solar thermal system cannot protrude more than 200 mm from the wall or the roof slope
- the solar thermal system cannot protrude past the highest point of the roof (the ridge line), excluding the chimney.

The criteria that must be met for **stand-alone systems** are that:

- only one stand-alone system is allowed in the grounds
- the array cannot exceed 4 m in height
- the array cannot be installed within 5 m of the boundary of the grounds
- the array cannot exceed 9 m² in area
- no dimension of the array can exceed 3 m in length.

The criteria that must be met for both **stand-alone and building-mounted systems** are that:

- the system cannot be installed in the grounds, or on a building within the grounds, of a listed building or a scheduled monument
- if the dwelling is in a conservation area or a World Heritage Site, then the array cannot be closer to a highway than the house or block of flats.

In every other case, planning permission will be required.

Compliance with Building Regulations

The Building Regulations applicable to the installation of solar thermal hot-water systems are outlined in Table 1.3.

ACTIVITY

Conduct research to investigate:

- how much water an average person uses in one day in the UK
- how much of this is hot water
- how much is returned as waste water.

▼ Table 1.3 Building Regulations applicable to solar thermal hot-water systems

Part	Title	Relevance
A	Structure	Where equipment and components can put extra load on the structure of the building, or the fabric requires modifications such as chases, suitability of the structure must be considered.
B	Fire safety	Where holes for pipes are made, this may reduce the fire resistance of the building fabric.
C	Site preparation and resistance to contaminants and moisture	Where holes for pipes and fixings for collectors are made, this may reduce the moisture resistance of the building and allow ingress of water.
G	Sanitation, hot-water safety and water efficiency	Hot-water safety and water efficiency must be considered.
L	Conservation of fuel and power	Energy efficiency of the system and the building as a whole must be considered.
P	Electrical safety	The installation of electrical controls and components must be considered.

Other regulatory requirements to consider

Other regulatory requirements to consider regarding the installation of solar thermal hot-water systems are:

- **BS 7671: 2018 (2022)** The IET Wiring Regulations, 18th Edition including amendments
- Approved Document Part G3: Unvented hot-water storage systems
- Water Regulations (WRAS).

The advantages and disadvantages of solar thermal hot-water systems

The advantages of solar thermal hot-water systems are that they:

- reduce CO₂ emissions
- reduce energy costs
- are low maintenance
- improve the energy rating of the building.

The disadvantages of solar thermal hot-water systems are that they:

- may not be compatible with the existing hot-water system
- may not meet demand for hot water in the winter
- have high initial installation costs
- require a linked auxiliary heat source.



▲ Figure 1.7 A heat pump moves heat from one location to another, just as a water pump like this one moves water from one location to another

Heat pumps

A water pump moves water from a lower level to a higher level, through the application of energy. Pumping the handle draws water up from a lower level to a higher level, through the application of kinetic energy.

As the name suggests, a heat pump moves heat energy from one location to another, through the application of energy. In most cases, the applied energy is electrical energy.

Working principles

Heat energy from the Sun exists in the air that surrounds us and in the ground beneath our feet. At absolute zero or 0 K (kelvin), there is no heat in a system. This temperature is equivalent to -273°C so, even with an outside temperature of -10°C , there is a vast amount of free heat energy available.



▲ Figure 1.8 Heat energy exists down to absolute zero ($0\text{ K} \approx -273^{\circ}\text{C}$)

Using a relatively small amount of energy, that stored heat energy in the air or in the ground can be extracted and used in the heating of living accommodation.

Heat pumps extract heat from outside and transfer it inside, in much the same way that a refrigerator extracts heat from the inside of the refrigerator and releases it at the back of the refrigerator via the heat-exchange fins.

A basic rule of heat transfer is that heat moves from warmer spaces to colder spaces.

A heat pump contains a refrigerant. The external air or ground is the medium or heat source that gives up its heat energy. The heat pump operates as follows.

- When the refrigerant is passed through the heat source, the refrigerant is cooler than its surroundings and so absorbs heat.
- The compressor on the heat pump then compresses the refrigerant, causing the gas to heat up.
- When the refrigerant is passed to the interior, the refrigerant is now hotter than its surroundings and gives up its heat to the cooler surroundings.
- The refrigerant is then allowed to expand, which converts it back into a liquid.
- As the refrigerant expands, it cools, and the cycle starts all over again.

The only energy needed to drive the system is the energy required by the compressor. The greater the difference in temperature between the refrigerant and the heat-source medium from where heat is being extracted, the greater the efficiency of the heat pump. If the heat-source medium is very cold, then the refrigerant will need to be colder, to be able to absorb heat, so the harder the compressor must work, and the more energy is needed to accomplish this.

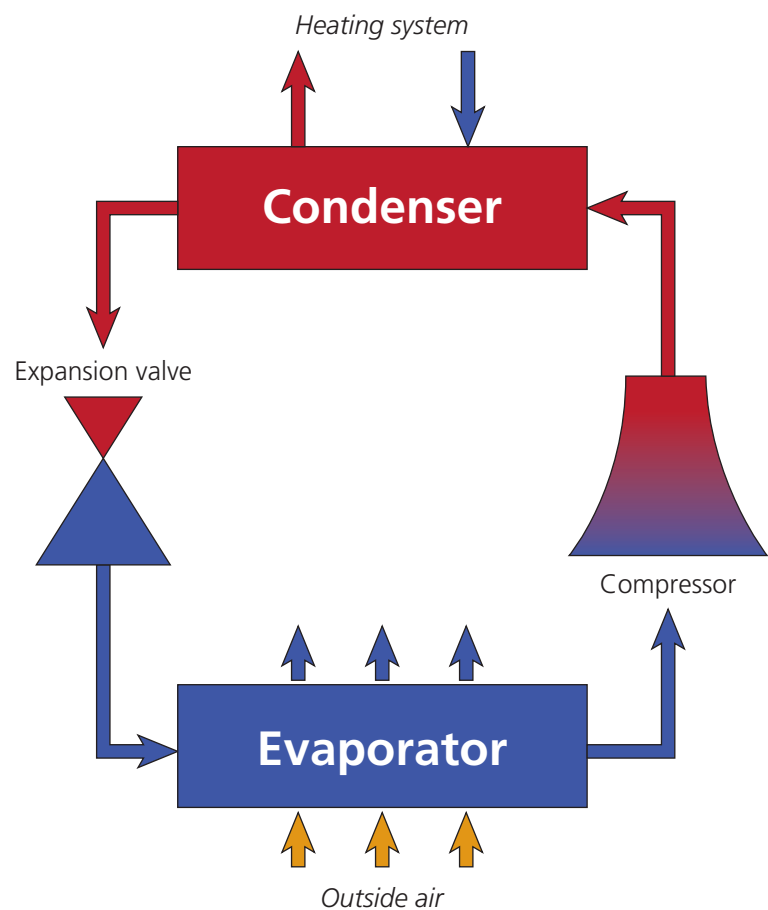

▲ Figure 1.9 The refrigeration process



▲ Figure 1.10a The efficiency of an electric panel heater

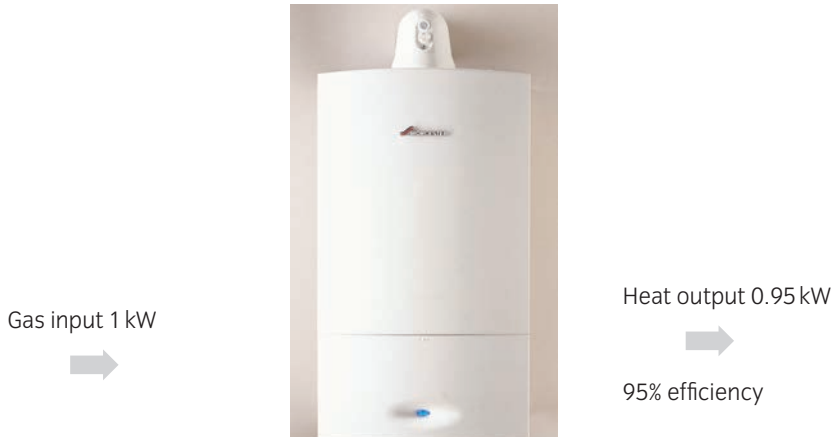

▲ Figure 1.10b The efficiency of an A-rated condensing gas boiler



▲ Figure 1.10c The efficiency of an air-source heat pump

INDUSTRY TIP

Air-source heat pumps are not just used to warm the inside of buildings; they can also cool the inside of buildings during hot days.

start operations will shorten the lifespan of a heat pump. A buffer tank, simply a large water-storage vessel, is incorporated into the circuit so that, when heat is not required within the premises, the heat pump can 'dump' heat to it and thus keep running. When there is a need for heat, this can be drawn from the buffer tank. A buffer tank can be used with both ground-source and air-source heat pumps.

Two main types of heat pump are in common use. They are:

- ground-source heat pumps (GSHPs)
- air-source heat pumps (ASHPs).

Heat pumps extract heat energy from the air or the ground, but the energy extracted is replaced by the action of the Sun. It is not uncommon for heat pumps to have efficiencies in the order of 300%; for an electrical input of 3 kW, a heat output of 9 kW is achievable. If we compare this with other heat appliances (see Figures 1.10 a–c), we can see where the savings are made.

The efficiency of a heat pump is measured in terms of the coefficient of performance (COP), which is the ratio between the heat delivered and the power input of the compressor.

$$\text{COP} = \frac{\text{heat delivered}}{\text{compressor power}}$$

The higher the COP value, the greater the efficiency. Higher COP values are achieved in mild weather than in cold weather because, in cold weather, the compressor has to work harder to extract heat.

Storing excess heat produced

Heat pumps are not able to provide instant heat and so therefore work best when run continuously. Stop–

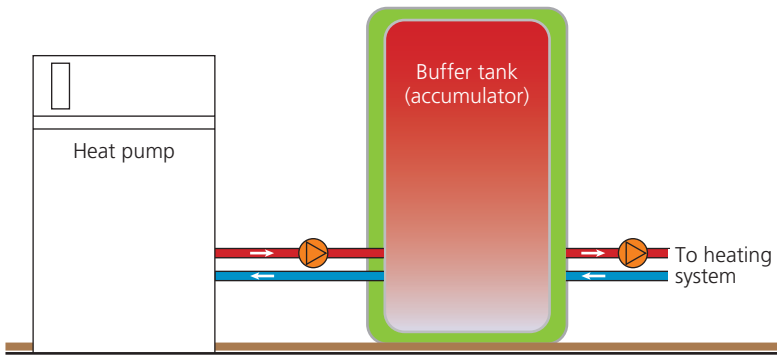

▲ Figure 1.11 Storing heat in a buffer tank

Ground-source heat pumps

A ground-source heat pump (GSHP) extracts low-temperature free heat from the ground, upgrades it to a higher temperature and then releases it, where required, for space heating and water heating.

Working principles

The key components of a GSHP are:

- heat-collection loops and a pump
- a heat pump
- a heating system.

The collection of heat from the ground is accomplished by means of pipes that are buried in the ground and contain a mixture of water and antifreeze. This type of system is known as a 'closed-loop' system. Three methods of burying the pipes are used. Each method has its advantages and disadvantages.

Horizontal loops

Piping is installed in horizontal trenches that are generally 1.5–2 m deep. Horizontal loops require more piping than vertical loops – around 200 m of piping for the average house.

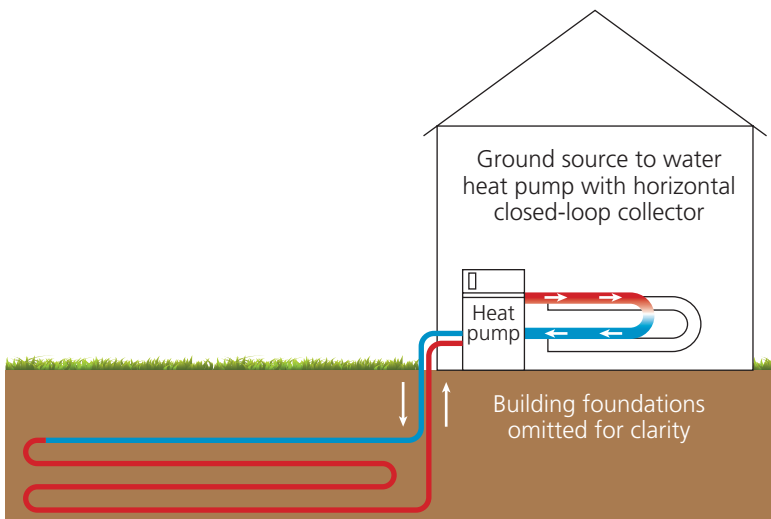

▲ Figure 1.12 Horizontal ground loops

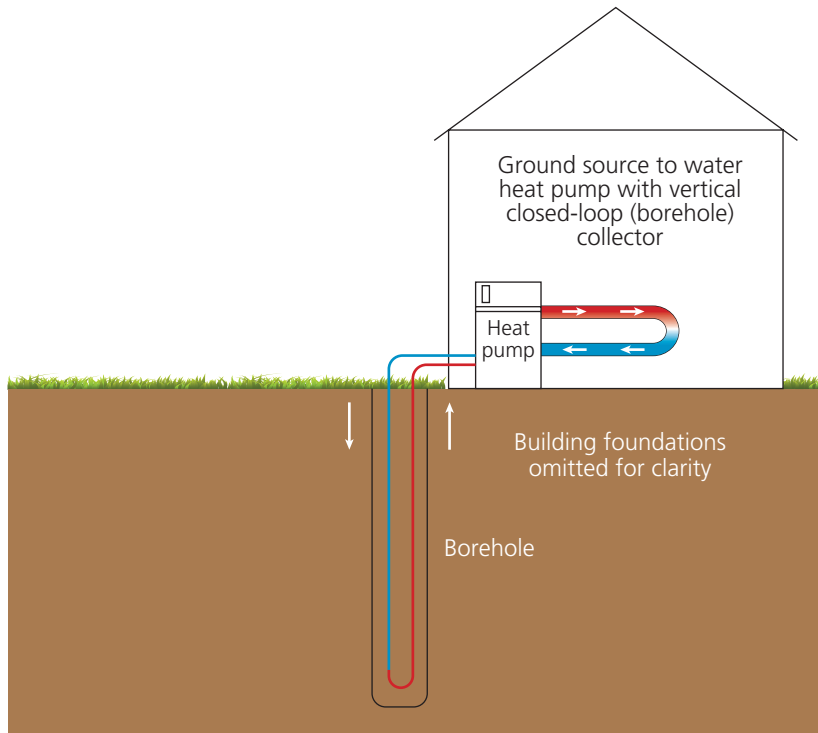

▲ Figure 1.13 Vertical ground loops

Vertical loops

Most commercial installations use vertical loops. Holes are bored to a depth of 15–60 m, depending on soil conditions, and spaced approximately 5 m apart. Pipe is then inserted into these bore holes. The advantage of this system is that less land is needed.

Slinkies

Slinky coils are flattened, overlapping coils that are spread out and buried, either vertically or horizontally. They are able to concentrate the area of heat transfer into a small area of land. This reduces the length of trench needing to be excavated and therefore the amount of land required. Slinkies installed in a 10 m long trench will yield around 1 kW of heating load.

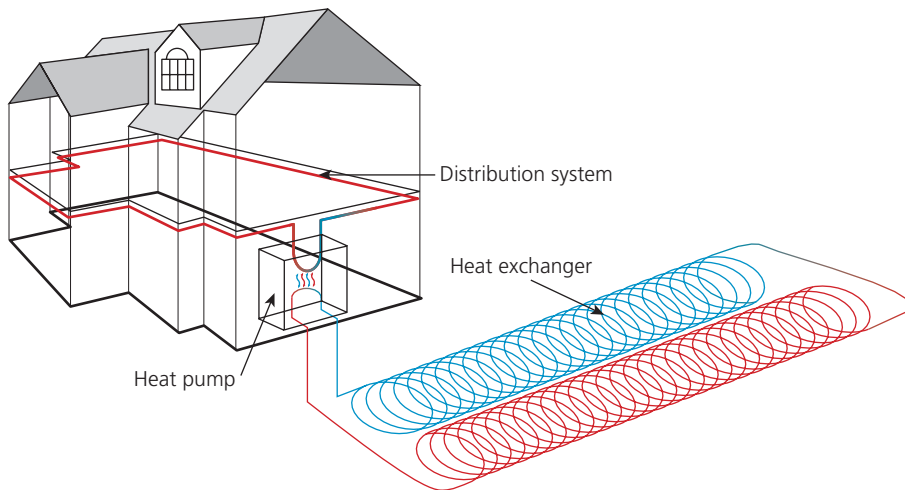

▲ Figure 1.14 Slinkies



▲ Figure 1.15 Slinkies being installed in the ground

The water–antifreeze mix is circulated around these ground pipes by means of a pump. The low-grade heat from the ground is passed over a heat exchanger, which transfers the heat from the ground to the refrigerant gas. The refrigerant gas is compressed and passed across a second heat exchanger, where the heat is transferred to a pumped heating loop that feeds either radiators or under-floor heating.

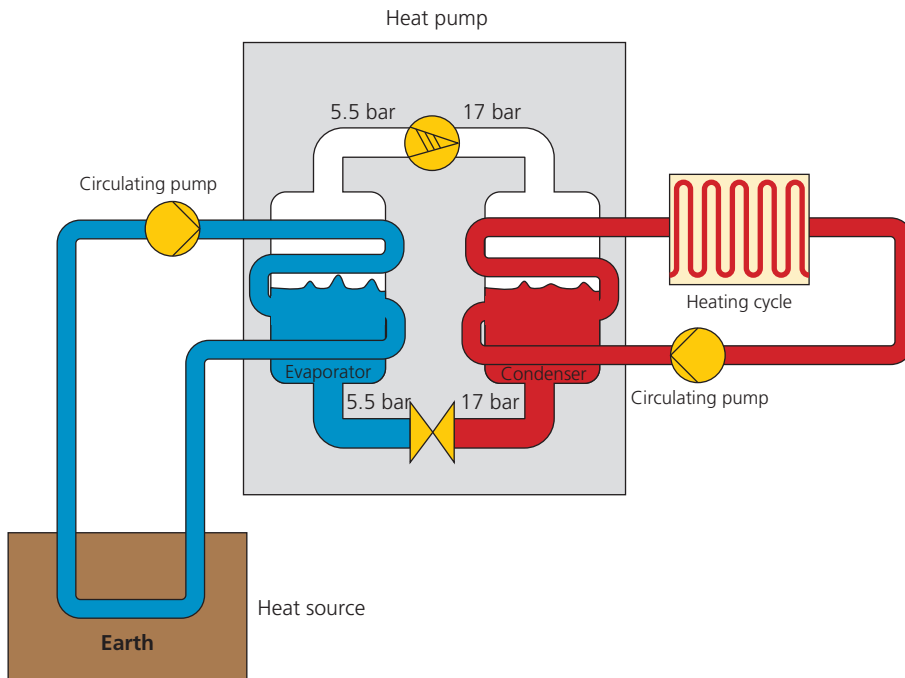

▲ Figure 1.16 Ground-source heat pump operating principle

Final heat output from the GSHP is at a lower temperature than would be obtained from a gas boiler. The heat output from a GSHP is at 40°C, compared with a gas boiler at 60–80°C. For this reason, under-floor heating, which requires temperatures of 30–35°C, is the most suitable form of heating arrangement to use with a GSHP. Low-temperature or oversized radiators could also be used.

A GSHP system, in itself, is unable to heat hot water directly to a suitable temperature. Hot water needs to be stored at a temperature of 60°C. An auxiliary heating device will be necessary in order to reach the required temperatures. A GSHP is unable to provide instant heat and, for maximum efficiency, should run all the time. In some cases, it is beneficial to fit a buffer tank to the output so that any excess heat is stored, ready to be used when required. By reversing the refrigeration process, a GSHP can also be used to provide cooling in the summer.

Location and building requirements

For a GSHP system to work effectively, and as the output temperature is low, the building must be well insulated.

A suitable amount of land has to be available for trenches or, alternatively, land that is suitable for bore holes. In either case, access for machinery will be required.

Planning permission

The installation of a GSHP is usually considered to be permitted development and will not require a planning application to be made.

If the building is a listed building or in a conservation area, the local area planning authority will need to be consulted.

Compliance with Building Regulations

The Building Regulations applicable to the installation of GSHPs are outlined in Table 1.4.

▼ Table 1.4 Building Regulations applicable to ground-source heat pumps

Part	Title	Relevance
A	Structure	Where equipment and components can put extra load on the structure of the building, or the fabric requires modification such as chases, suitability of the structure must be considered.
B	Fire safety	Where holes for pipes are made, this may reduce the fire resistance of the building fabric.
C	Site preparation and resistance to contaminants and moisture	Where holes for pipes and fixings for equipment are made, this may reduce the moisture resistance of the building and allow ingress of water.
E	Resistance to the passage of sound	Where holes for pipes are made, this may reduce the soundproof integrity of the building structure.
G	Sanitation, hot-water safety and water efficiency	Hot-water safety and water efficiency must be considered.
L	Conservation of fuel and power	Energy efficiency of the system and the building as a whole must be considered.
P	Electrical safety	The installation of electrical controls and components must be considered.

INDUSTRY TIP

The GOV.UK website provides guidance on the qualifications required to work on equipment containing F (fluorinated) gas.

Other regulatory requirements to consider

Other regulatory requirements to consider regarding the installation of GSHPs are:

- **BS 7671: 2018 (2022)** The IET Wiring Regulations, 18th Edition including amendments
- F (fluorinated) gas requirements, if working on refrigeration pipework.

Furthermore, you must be qualified in order to work on refrigeration pipework.

The advantages and disadvantages of ground-source heat pumps

The advantages of GSHPs are that they:

- are highly efficient
- are cheaper to run than electric, gas or oil boilers, leading to a reduction in the cost of energy bills
- reduce CO₂ emissions
- generate no CO₂ emissions on site
- are safe, because no combustion takes place and there is no emission of potentially dangerous gases
- are low maintenance compared with combustion devices
- have a long lifespan
- do not require fuel storage, so less installation space is required
- can be used to provide cooling in the summer
- are more efficient than air-source heat pumps.

The disadvantages of GSHPs are that:

- the initial costs are high
- they require a large area of land

- the design and installation are complex tasks
- they are unlikely to work efficiently with an existing heating system
- they use refrigerants, which could be harmful to the environment
- they are more expensive to install than air-source heat pumps.

Air-source heat pumps

An air-source heat pump (ASHP) extracts free heat from low-temperature air and releases it, where required, for space heating and water heating.

The key components of an ASHP are:

- a heat pump containing a heat exchanger, a compressor and an expansion valve
- a heating system.

Working principles

An ASHP works in a similar way to a refrigerator, but the cooled area becomes the outside world and the area where the heat is released is the inside of a building.

The steps involved in the ASHP process are as follows.

- The pipes of the pump system contain refrigerant that can be a liquid or a gas, depending on the stage of the cycle. The refrigerant, as a gas, flows through a heat exchanger (evaporator), where low-temperature air from outside is drawn across the heat exchanger by means of the unit's internal fan. The heat from the air warms the refrigerant. Any liquid refrigerant boils to gas.
- The warmed refrigerant vapour then flows to a compressor. Here, the refrigerant vapour is compressed, causing its temperature to rise further.
- Following this pressurisation stage, the refrigerant gas passes through another heat exchanger (condenser), where it loses heat to the heating-system water, because it is hotter than the system water. At this stage, some of the refrigerant has condensed to a liquid. The heating system carries heat away to heat the building.
- The cooled refrigerant passes through an expansion valve, where its pressure drops suddenly and its temperature falls. The refrigerant flows once more to the evaporator heat exchanger, continuing the cycle.

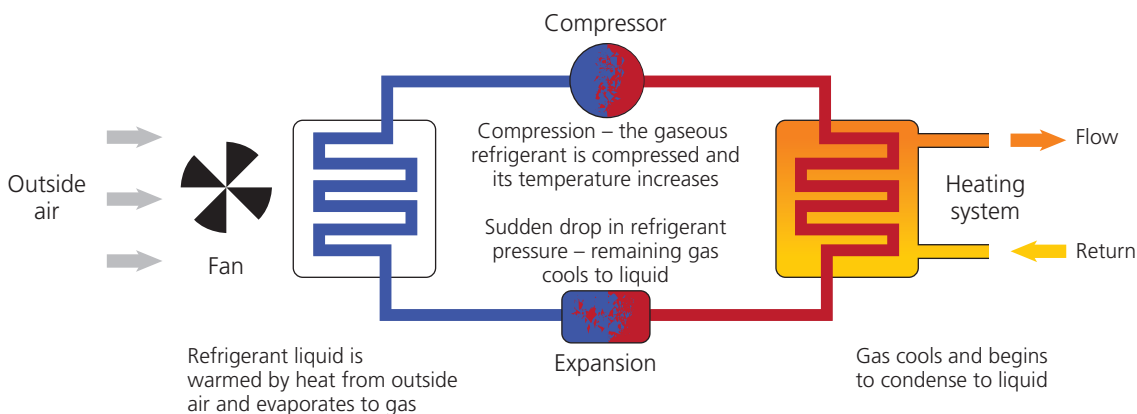

▲ Figure 1.17 Air-source heat pump operating principle

There are two types of ASHP in common use. These are:

- air-to-water pumps
- air-to-air pumps.

An air-to-water pump is the pump described above, and it can be used to provide both space heating and water heating. An air-to-air pump is not suitable for providing water heating.

The output temperature of an ASHP will be lower than that of a gas-fired boiler. Ideally, the ASHP should be used in conjunction with an under-floor heating system. Alternatively, it could be used with low-temperature radiators.

Location and building requirements

The following factors should be considered when deciding whether or not an ASHP is suitable for particular premises.

- The premises must be well insulated.
- There must be space to fit the unit on the ground outside the building or to mount it on a wall. There will also need to be clear space around the unit to allow an adequate airflow.
- The ideal heating system to couple to an ASHP is either under-floor heating or warm-air heating.
- An ASHP will pay for itself in a shorter period of time if it replaces an electric, coal or oil heating system rather than a gas-fired boiler.

Air-source heat pumps are an ideal solution for new-build properties, where high levels of insulation and under-floor heating are to be installed.

Planning permission

Permitted development applies where an ASHP is installed:

- on a dwelling house or block of flats
- on a building within the grounds of a dwelling house or block of flats
- in the grounds of a dwelling house or block of flats.

There are, however, criteria to be met, mainly due to noise generated by the ASHP.

- The ASHP must comply with the Microgeneration Certification Scheme (MCS) Planning Standards or equivalent.
- Only one ASHP may be installed on the building or within the grounds of the building.
- A wind turbine must not be installed on the building or within the grounds of the building.
- The volume of the outdoor unit's compressor must not exceed 0.6 m³.
- The ASHP cannot be installed within 1 m of the boundary.
- The ASHP cannot be installed on a pitched roof.
- If the ASHP is installed on a flat roof, it must not be within 1 m of the roof edge.
- The ASHP cannot be installed on a site designated as a monument.

- The ASHP cannot be installed on a building that is a listed building, or in its grounds.
- The ASHP cannot be installed on a roof or a wall that fronts a highway, or within a conservation area or World Heritage Site.
- If the dwelling is in a conservation area or a World Heritage Site, then the ASHP cannot be closer to a highway than the house or block of flats.

Compliance with Building Regulations

The Building Regulations applicable to the installation of ASHPs are outlined in Table 1.5.

▼ Table 1.5 Building Regulations applicable to air-source heat pumps

Part	Title	Relevance
A	Structure	Where equipment and components can put extra load on the structure of the building, or the fabric requires modification such as chases, the suitability of the structure must be considered.
B	Fire safety	Where holes for pipes are made, this may reduce the fire resistance of the building fabric.
C	Site preparation and resistance to contaminates and moisture	Where holes for pipes and fixings for equipment are made, this may reduce the moisture resistance of the building and allow ingress of water.
E	Resistance to the passage of sound	Where holes for pipes are made, this may reduce the soundproof integrity of the building structure.
G	Sanitation, hot-water safety and water efficiency	Hot-water safety and water efficiency must be considered.
L	Conservation of fuel and power	Energy efficiency of the system and the building as a whole must be considered.
P	Electrical safety	The installation of electrical controls and components must be considered.

Other regulatory requirements to consider

Other regulatory requirements to consider regarding the installation of ASHPs are:

- **BS 7671: 2018 (2022)** The IET Wiring Regulations, 18th Edition including amendments
- F (fluorinated) gas regulations, if working on refrigeration pipework.

The advantages and disadvantages of air-source heat pumps

The advantages of ASHPs are that they:

- are highly efficient
- are cheaper to run than electric, gas or oil boilers, leading to reductions in the cost of energy bills
- reduce CO₂ emissions
- generate no CO₂ emissions on site
- are safe, because no combustion takes place and there is no emission of potentially dangerous gases
- are low maintenance compared with combustion devices
- do not require fuel storage, so less installation space is required

- can be used to provide cooling in the summer
- are cheaper and easier to install than ground-source heat pumps.

The disadvantages of ASHPs are that they:

- are unlikely to work efficiently with an existing heating system
- are not as efficient as ground-source heat pumps
- have high initial costs
- are less efficient in the winter than in the summer
- generate noise from the fans
- have to incorporate a defrost cycle to stop the heat exchanger freezing in the winter.

Biomass

The major difference between biomass and fossil fuels, both of which are derived from the same source, is time. Fossil fuels, such as gas, oil and coal, have taken millions of years to form. Demand for these fuels is outstripping supply and replenishment. **Biomass** is derived from recently living organisms. As long as these organisms are replaced by replanting, and demand does not exceed replacement time, the whole process is sustainable. Biomass is therefore rightly regarded as a renewable energy technology.

KEY TERM

Biomass: The biological material from living or recently living organisms; biomass fuels are usually derived from plant-based material but could be derived from animal material. Fuel pellets can be made from woodworking offcuts, cereals or grain products, oils, animal fats and waste fish products.

VALUES AND BEHAVIOURS

Where possible, the use of sustainable fuel sources should be encouraged. Biomass fuel products are much more readily available and significantly faster to produce, so offer a viable and sustainable alternative to fossil fuel consumption.

However, be mindful of the fact that biomass fuels still produce greenhouse gas emissions, which have a detrimental effect on the environment.

Both fossil fuels and biomass fuels are burned to produce heat, and both fuel types release CO₂ as part of this process. Carbon dioxide is a greenhouse gas that has been linked to global warming. During their lives, plants and trees absorb CO₂ from the atmosphere, to enable growth to take place. When these plants are burned, the CO₂ is released once again into the atmosphere.

Biomass fuels have two main carbon advantages over fossil fuels.

- Fossil fuels absorbed CO₂ from the atmosphere millions of years ago and have trapped that CO₂ ever since. When fossil fuels are burned, they release the CO₂ from all those millions of years ago and so add to the present-day atmospheric CO₂ level.
- Biomass absorbs CO₂ when it grows, reducing current atmospheric CO₂ levels. When biomass is turned into fuel and burned, it releases the CO₂ back into the atmosphere. The net result is that there is no overall increase in the amount of CO₂ in the atmosphere.

A disadvantage of biomass is that the material is less dense than fossil fuels, so to achieve the same heat output, a greater quantity of biomass than fossil fuel is required. However, with careful management, the use of biomass is sustainable, whereas the use of fossil fuels is not.

The classes of biomass raw material that can be turned into biomass fuels are:

- wood
- crops, such as elephant grass, reed canary grass and rapeseed
- agricultural by-products, such as straw, grain husks and forest product waste, and animal waste, such as chicken litter and slurry
- food waste; it is estimated that some 35% of food purchased ends up as waste
- industrial waste.

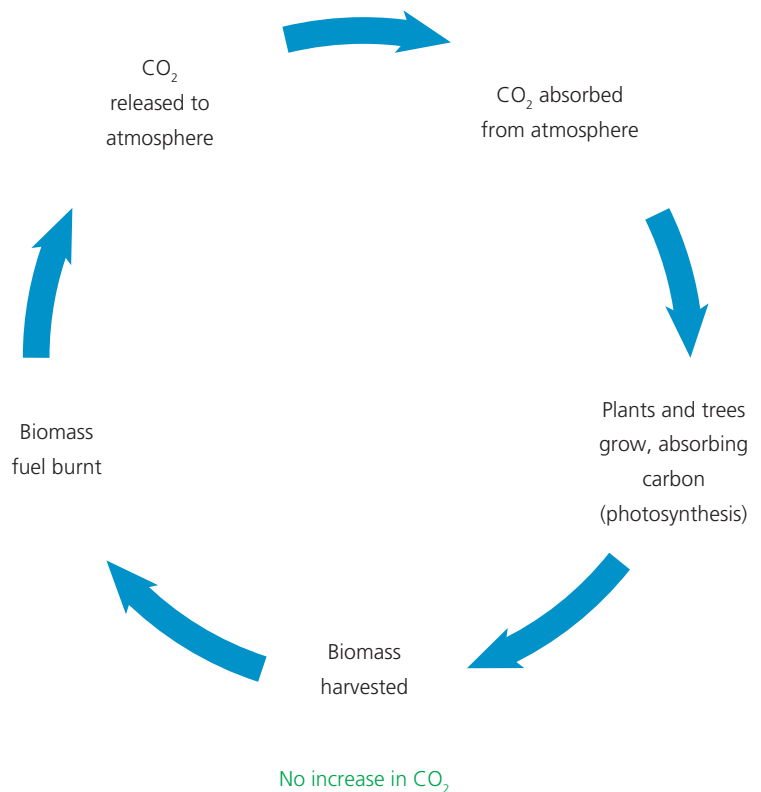

▲ Figure 1.18 The carbon cycle

Woody biomass

Wood-related products are the primary biomass fuels for domestic use.

For wood to work as a sustainable material, the trees used need to be relatively fast growing, so short-rotation coppice woodlands containing willow, hazel and poplar are used on a 3–5-year rotation. Because of this, large logs are not available, neither can slow-growing timbers that would have a higher **calorific value** be used. Woody biomass as a fuel is generally supplied as:

- small logs
- wood chips – mechanically shredded trees, branches, etc.
- wood pellets – made from sawdust or wood shavings that are compressed to form pellets.

The calorific value of woody biomass is generally low. The greener (wetter) the wood is, the lower the calorific value will be.

Woody biomass boilers

A biomass boiler can be as simple as a log-burner providing heat to a single room or may be a boiler heating a whole house. Woody biomass boilers can be automated so that a constant supply of fuel is available. Wood pellets are transferred to a combustion chamber by means of an auger drive or, if the fuel storage is remote from the boiler, by a suction system. The combustion process is monitored via thermostats in the flue gases, and adjustments are made to the fan speed, which controls air intake, and to the fuel-feed system, to control the feed of pellets. All of this is controlled by a microprocessor.

KEY TERM

Calorific value: Energy given off by burning.

INDUSTRY TIP

In automated biomass boilers, the heat exchangers are self-cleaning and the amount of ash produced is relatively small. As a result, the boilers require little maintenance. The waste gases are taken away from the boiler by the flue and are then dispersed via the flue terminal.

The hot flue gases are passed across a heat exchanger, where the heat is transferred to the water in the central-heating system. From this point, the heated water is circulated around a standard central-heating system.

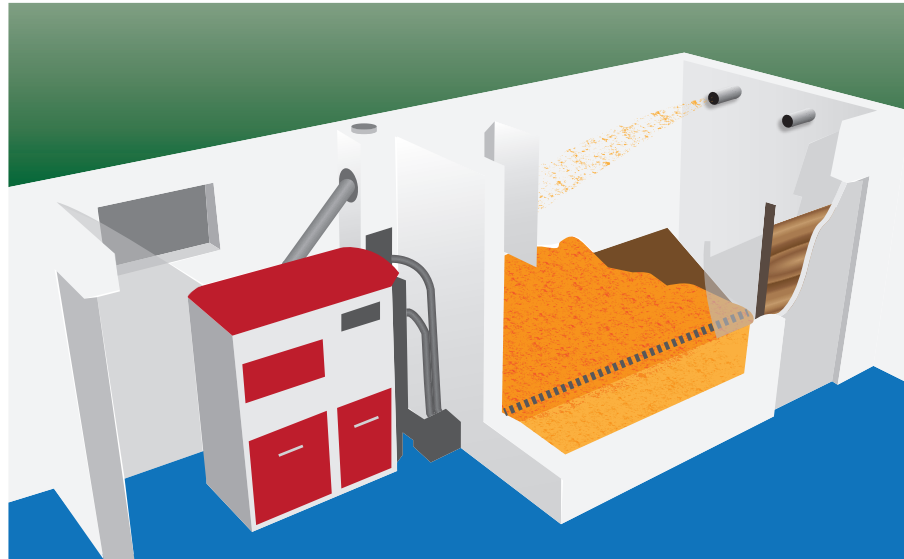

▲ Figure 1.19 Biomass boiler with suction feed system

Location and building requirements

The following factors should be considered when deciding whether or not a biomass boiler is suitable for particular premises.

- Space will be required for the storage of the biomass fuel.
- Easy access will be required for the delivery of the biomass fuel.
- A biomass boiler may not be permitted in a designated smokeless zone.

Smoke-control areas and exempt appliances

In the past, when it was common to burn coal as a source of domestic heat or for the commercial generation of heat and power, many cities suffered from very poor air quality. Smogs, which are a mixture of winter fog and smoke, were frequent occurrences.

These smogs contained high levels of sulphur dioxide and smoke particles, both of which are harmful to humans. In December 1952, a period of windless conditions prevailed, resulting in a smog in London that lasted for five days. Apart from very poor visibility, it was estimated at the time that this smog contributed to some 4000 premature deaths and another 100 000 people suffered smog-related illnesses. With improved scientific research, it is now suspected that these figures were seriously underestimated and as many as 12 000 people may have died. Not surprisingly, there was a massive public outcry, which led to the government introducing the Clean Air Act 1956 and local authorities declaring areas as 'smoke-control areas'.

The Clean Air Act of 1956 was replaced in 1993. Under this act, it is an offence to sell or burn an unauthorised fuel in a smoke-control area unless it is burned in

what is known as an 'exempt appliance'. Exempt appliances are able to burn fuels that would normally be 'smoky', without emitting smoke to the atmosphere. Each appliance is designed to burn a specific fuel.

Planning permission

Planning permission will not normally be required for the installation of a biomass boiler in a domestic dwelling if the entire work is internal to the building. If the installation requires an external flue to be installed, it will normally be classed as permitted development, on the condition that the flue is to the rear or side elevation and does not extend more than 1 m above the highest part of the roof.

ACTIVITY

Use an internet search to research the different types of biomass fuels that are approved for use in domestic properties.

Listed building or buildings in a designated area

Check with the local planning authority with regards to both internal work and external flues, because many local authorities will not permit changes to a building's structure or appearance if the building is listed or in a conservation area.

Buildings in a conservation area or in a World Heritage Site

Flues should not be fitted on the principal or side elevation if they would be visible from a highway.

If the project includes the construction of buildings for the storage of biofuels or to house the boiler, then the same planning requirements as for extensions and garden outbuildings will apply.

Compliance with Building Regulations

The Building Regulations applicable to biomass fuels are outlined in Table 1.6.

▼ Table 1.6 Building Regulations applicable to biomass fuels

Part	Title	Relevance
A	Structure	Where equipment and components can put extra load on the structure of the building, or the fabric requires modifications such as chases, the suitability of the structure must be considered.
B	Fire safety	Where holes for pipes are made, this may reduce the fire resistance of the building fabric.
C	Site preparation and resistance to contaminants and moisture	Where holes for pipes and fixings for equipment are made, this may reduce the moisture resistance of the building and allow ingress of water.
E	Resistance to the passage of sound	Where holes for pipes are made, this may reduce the soundproof integrity of the building structure.
G	Sanitation, hot-water safety and water efficiency	Hot-water safety and water efficiency must be considered.
J	Combustion appliances and fuel-storage systems	Biomass boilers produce heat and therefore must be installed correctly.
L	Conservation of fuel and power	Energy efficiency of the system and the building as a whole must be considered.
P	Electrical safety	The installation of electrical controls and components must be considered.

The advantages and disadvantages of biomass fuels

The advantages of biomass fuels are that:

- they are carbon neutral
- they are a sustainable fuel source
- when biomass fuels are burned, the waste gases are low in nitrous oxide, with no sulphur dioxide – both are greenhouse gases.

The disadvantages of biomass fuels are that:

- transportation costs are high; wood pellets or wood chips will need to be delivered in bulk to make delivery costs viable
- storage space is needed for the fuel; as woody biomass has a low calorific value, a large quantity of fuel will be required
- consideration must be given as to whether or not adequate storage space is available
- when a solid fuel is burned, it is not possible to have instant control of heat, as would be the case with a gas boiler; the fuel source cannot be instantly removed to stop combustion
- they require a suitable flue system.

ELECTRICITY-PRODUCING MICRO-RENEWABLE ENERGY TECHNOLOGIES

KEY TERM

Micro-renewable energy: Small-scale generation of energy that is collected from renewable resources which are naturally replenished on a human timescale, such as sunlight, wind, rain, tides, waves and geothermal heat.

The following electricity-producing **micro-renewable energy** technologies are discussed in this section:

- solar photovoltaic
- micro-wind
- micro-hydro.

A major advantage of electricity-producing micro-renewable energy technologies is that they do not use any of the planet's dwindling fossil fuels. They also do not produce any CO₂ when in operation. For each of the electricity-producing micro-renewable energy technologies, two types of connection exist.

- With an on-grid or grid-tied connection, the system is connected in parallel with the grid-supplied electricity.
- With an off-grid connection, the system is not connected to the grid but supplies electricity directly to current-using equipment or is used to charge batteries and then supplies electrical equipment via an inverter.

The batteries required for off-grid systems need to be deep-cycle type batteries, which are expensive to purchase. The other downside of using batteries to store electricity is that their lifespan may be as short as five years, after which the battery bank will need replacing.

With on-grid systems, any excess electricity generated is exported back to the grid. At times when the generation output is not sufficient to meet the demand, electricity is imported from the grid.

While the following sections will focus primarily on on-grid or grid-tied systems, which are the most common connection types in use, an overview of the components required for off-grid systems is included, to provide a complete explanation of the technology.

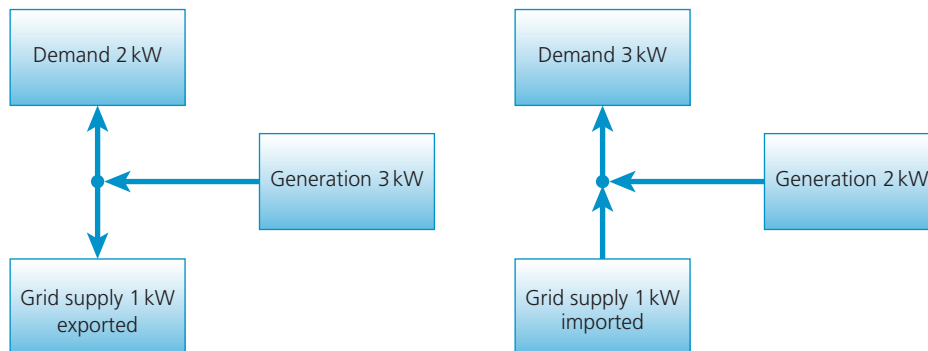

▲ Figure 1.20a Generation exceeds demand

▲ Figure 1.20b Demand exceeds generation

Solar photovoltaic

Solar photovoltaic (PV) is the conversion of light into electricity. Light is electromagnetic energy and, in the case of visible light, is electromagnetic energy that is visible to the human eye. The electromagnetic energy released by the Sun consists of a wide spectrum, most of which is not visible to the human eye and cannot be converted into electricity by PV modules.

Working principles

The basic element of photovoltaic energy production is the PV cell, which is made from **semiconductor** material. While various semiconductor materials can be used in the making of PV cells, the most common material is silicon. Adding a small quantity of a different element (an impurity) to the silicon, a process known as 'doping', produces n-type or p-type semiconductor material. Whether it is n-type (negative) or p-type (positive) semiconductor material is dependent on the element used to dope the silicon. Placing an n-type and a p-type semiconductor material together creates a p-n junction. This forms the basis of all semiconductors used in electronics.

When **photons** hit the surface of the PV cell, they are absorbed by the p-type semiconductor material. The additional energy provided by these photons allows electrons to overcome the bonds holding them and to move within the semiconductor material, thus creating a potential difference or – in other words – generating a voltage.

Photovoltaic cells have an output voltage of 0.5 V, so a number of these cells are linked together to form modules with resulting higher voltage and power outputs. Modules are connected in series to increase voltage. These are known as 'strings'. All the modules together are known as an 'array'. An array therefore can comprise a single string or multiple strings. The connection arrangements are determined by the size of the system and the choice of inverter. It should be noted that PV arrays can attain DC voltages of many hundreds of volts.

KEY TERMS

Semiconductor: A material with resistivity that sits between that of an insulator and a conductor.

Photons: Particles of energy from the Sun.



▲ Figure 1.21 Photovoltaic cell

There are many arrangements for PV systems but they can be divided into two categories:

- off-grid systems, where the PV modules are used to charge batteries
- on-grid systems, where the PV modules are connected to the grid supply via an inverter.

Off-grid systems where the PV modules are used to charge batteries

The key components of an off-grid PV system are:

- PV modules
- a PV module mounting system
- DC cabling
- a charge controller
- a deep-discharge battery bank
- an inverter.

Other components, such as isolators, will also be required.

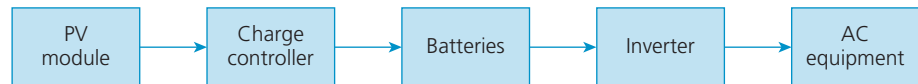

▲ Figure 1.22 Off-grid system components

Off-grid systems are ideal where no mains supply exists and there is a relatively small demand for power. Deep-discharge batteries are expensive and will need replacing within 5–10 years, depending on use.

On-grid systems where the PV modules are connected to the grid supply via an inverter

The key components of an on-grid PV system are:

- PV modules
- a PV module mounting system
- DC cabling
- an inverter
- AC cabling
- metering
- a connection to the grid.

Other components, such as isolators, will also be required.

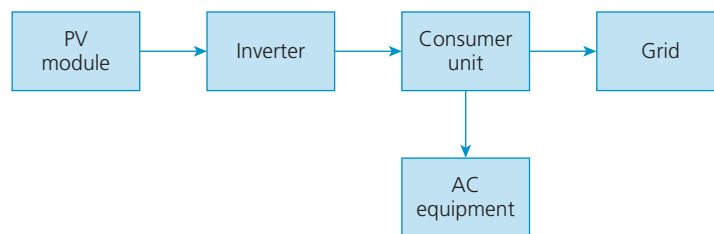

▲ Figure 1.23 On-grid system components

PV modules

Different types of module, of various efficiencies, are available. The performance of a PV module is expressed as an **efficiency percentage**.

- Monocrystalline modules range in efficiency from 15% to 20%.
- Polycrystalline modules range in efficiency from 13% to 16% but are cheaper to purchase than monocrystalline modules.
- Amorphous film ranges in efficiency from 5% to 7%. Amorphous film is low efficiency but is flexible, so it can be formed into curves and is ideal for surfaces that are not flat.

While efficiencies may appear low, the maximum theoretical efficiency that can be obtained with a single junction silicon cell is only 34%.

PV module mounting system

Photovoltaic modules can be fitted as in-roof systems, on-roof systems, ground-mounted systems or pole-mounted systems.

In **in-roof systems** the modules replace the roof tiles. The modules used are specially designed to interlock, to ensure that the roof structure is watertight. The modules are fixed directly to the roof structure. Several different systems are on the market, from single tile size to large panels that replace a whole section of roof tiles. In-roof systems cost more than on-roof systems but are more aesthetically pleasing. In-roof systems are generally only suitable for new-build projects or where the roof is to be retiled.

On-roof systems are the common method employed for retrofit systems. Various different mounting systems exist for securing the modules to the roof structure. Most consist of aluminium rails, which are fixed to the roof structure by means of roof hooks. Mounting systems also exist for fitting PV modules to flat roofs. Checks will need to be made to ensure that the existing roof structure can withstand the additional weight and also the uplift forces that will be exerted on the PV array by the wind.



▲ Figure 1.25 Roof-mounted system

KEY TERM

Efficiency percentage:
The higher the percentage, the greater the efficiency.



▲ Figure 1.24 In-roof mounted system



▲ Figure 1.26 Ground-mounted systems in a solar farm

Ground-mounted systems and **pole-mounted systems** are available for free-standing PV arrays.

Tracking systems are the ultimate in PV mounting systems. These are computer-controlled motorised mounting systems that change both **azimuth** and tilt to track the Sun as it passes across the sky. Ideally the modules should face south, but any direction between east and west will give acceptable outputs.

Inverter

The inverter's primary function is to convert the DC input to a 230 V AC 50 Hz output and synchronise it with the mains supply frequency. The inverter also ensures that, in the event of mains supply failure, the

PV system does not create a danger by continuing to feed power onto the grid. The inverter must be matched to the PV array with regards to power and DC input voltage, to avoid damage to the inverter and to ensure that it works efficiently. Both DC and AC isolators will be fitted to the inverter, to allow it to be isolated for maintenance purposes.

Metering

A generation meter is installed on the system to record the number of units generated, so that the feed-in tariff can be claimed, where applicable.

Connection to the grid

Connection to the grid within domestic premises is made via a spare way in the consumer unit and a 16 A overcurrent protective device. An isolator is fitted at the intake position to provide emergency switching, so that the PV system can easily be isolated from the grid.

Location and building requirements

The following factors should be considered when deciding on the suitability of a location or a building for the installation of a PV system.

KEY TERM

Azimuth: Refers to the angle that the panel direction **diverges** from facing due south.

KEY TERM

Diverges: When something is off line by an amount or differs.



▲ Figure 1.27 Photovoltaic inverter

IMPROVE YOUR MATHS

Adequate roof space available

The roof space available determines the maximum size of PV array that can be installed. In the UK, all calculations are based on 1000 Wp (watts peak) of the Sun's radiation on 1 m². So, if the array uses modules with a 15% efficiency, each 1 kWp of array will require approximately 7 m² of roof space. The greater the efficiency of the modules, the less roof space required.

The orientation (azimuth) of the PV array

The optimum direction for the solar collectors to face is due south. However, as the Sun rises in the east and sets in the west, any location with a roof facing east, south or west is suitable for mounting a PV array, but the efficiency of the system will be reduced for any system not facing due south.

The tilt of the PV array

Throughout the year, the height of the Sun relative to the horizon changes from its lowest in December through to its highest in June. As it is generally impractical to vary the tilt angle throughout the year, the optimum tilt for the PV array in the UK is between 30° and 40° . However, the modules will work outside the optimum tilt range and will even work if vertical or horizontal, but they will be less efficient.

Shading of the PV array

Any structure, tree, chimney, aerial or other object that stands between the PV array (collector) and the Sun will prevent some of the Sun's energy from reaching the collector. The Sun shines for a limited time and any reduction in the amount of sunlight landing on the collector will reduce the collector's ability to produce electricity.

Location within the UK

The location within the UK will determine how much sunshine will fall, annually, on the PV array and, in turn, this will determine the amount of electricity that can be generated. For example, a location in Brighton will generate more electricity than one in Newcastle, purely because Brighton receives more sunshine.

The suitability of the structure for mounting the solar collector

The structure must be assessed for its suitability for mounting the chosen solar collector. Consideration needs to be given to the strength of the structure, the suitability of fixings and the condition of the structure. Consideration also needs to be given to the effect known as 'wind uplift', an upward force exerted by the wind on the module and mounting system. The PV array fixings and the fixings holding the roof members to the building structure must be strong enough to allow for wind uplift.

In the case of roof-mounted systems on blocks of flats and other shared properties, consideration must also be given to the ownership of the structure on which the proposed system is to be installed.

A suitable place to mount the inverter

The inverter is usually mounted either in the loft space or at the mains position.

Connection to the grid

A spare way within the consumer unit will need to be available for connection of the PV system. If a spare way is not available, then the consumer unit may need to be changed.

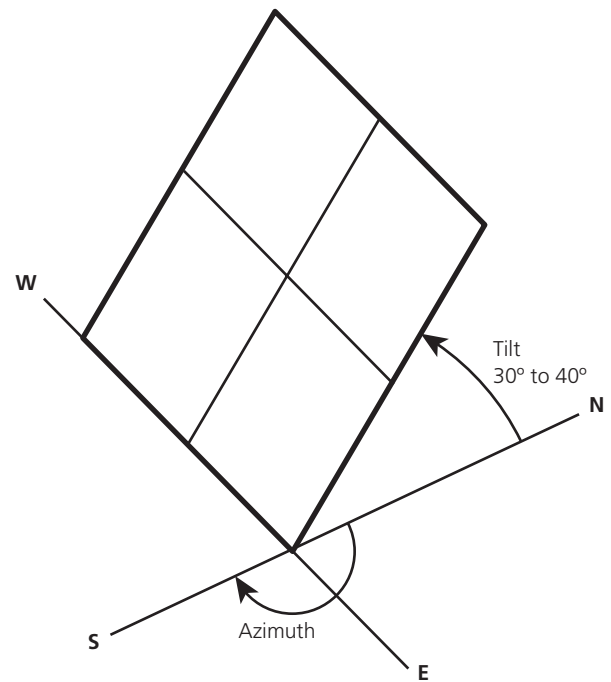

PV array facing south at fixed tilt

▲ Figure 1.28 PV array facing south at fixed tilt: the ideal tilt is $30\text{--}40^\circ$



▲ Figure 1.29 Building features shading a photovoltaic system

Planning permission

Permitted development applies where a PV system is installed:

- on a dwelling house or block of flats
- on a building within the grounds of a dwelling house or block of flats
- as a stand-alone system in the grounds of a dwelling house or block of flats.

However, there are criteria to be met in each case.

For building-mounted systems:

- the PV system must not protrude more than 200 mm from the wall or the roof slope
- the PV system must not protrude past the highest point of the roof (the ridge line), excluding the chimney.

For stand-alone systems:

- only one stand-alone system is allowed in the grounds
- the array must not exceed 4 m in height
- the array must not be installed within 5 m of the boundary of the grounds
- the array must not exceed 9 m² in area
- no dimension of the array may exceed 3 m in length.

For both building-mounted and stand-alone systems, the following criteria must be met.

- The system must not be installed in the grounds, or on a building within the grounds, of a listed building or a scheduled monument.
- If the dwelling is in a conservation area or a World Heritage Site, then the array must not be closer to a highway than the house or block of flats.

In every other case, planning permission will be required.

Compliance with Building Regulations

The Building Regulations applicable to the installation of solar PV systems are outlined in Table 1.7.

▼ Table 1.7 Building Regulations applicable to solar photovoltaic systems

Part	Title	Relevance
A	Structure	Where equipment and components can put extra load on the structure of the building, or the fabric requires modifications such as chases, the suitability of the structure must be considered.
B	Fire safety	Where holes for cables are made, this may reduce the fire resistance of the building fabric.
C	Site preparation and resistance to contaminants and moisture	Where holes for cables and fixings for the system are made, this may reduce the moisture resistance of the building and allow ingress of water.
E	Resistance to the passage of sound	Where holes for cables are made, this may reduce the soundproof integrity of the building structure.
L	Conservation of fuel and power	Energy efficiency of the system and the building as a whole must be considered.
P	Electrical safety	The installation of electrical controls and components must be considered.

Other regulatory requirements to consider

Other regulatory requirements to consider regarding the installation of solar PV systems are:

- **BS 7671: 2018 (2022)** The IET Wiring Regulations, 18th Edition, including amendments
- G98 requirements in relation to on-grid systems up to and including 16 A per phase; above this size, the requirements of G99 will need to be complied with
- Microgeneration Certification Scheme (MCS) requirements.

The advantages and disadvantages of solar photovoltaic systems

The advantages of solar PV systems are that:

- they can be fitted to most buildings
- excess electricity can be sold back to the distribution network operator
- there is a reduction in the amount of electricity imported
- they use zero-carbon technology
- they improve energy performance certificate ratings
- there is a reasonable payback period on the initial investment.

The disadvantages of solar PV systems are described below.

- The initial cost is high.
- The size of the system is dependent on available, suitable roof area.
- They require a relatively large array to offset installation costs.
- They give variable output that is dependent on the amount of sunshine available. Lowest output is at times of greatest requirement, such as at night and in the winter. Savings need to be considered over the whole year.
- There is an aesthetic impact (on the appearance of the building).

Micro-wind

Wind turbines harness energy from the wind and turn it into electricity. The UK is an ideal location for the installation of wind turbines as about 40% of Europe's wind energy passes over the UK. A micro-wind turbine installed on a suitable site could easily generate more power than would be consumed on site.

Working principles

A wind turbine operates as follows.

- Wind passing the rotor blades of the turbine causes the turbine to turn.
- The hub of the turbine is connected by a low-speed shaft to a gearbox.
- The gearbox output is connected to a high-speed shaft that drives a generator which, in turn, produces electricity.

Turbines are available as either horizontal-axis wind turbines (HAWTs) or vertical-axis wind turbines (VAWTs). A HAWT has a tailfin to turn the turbine so that it is

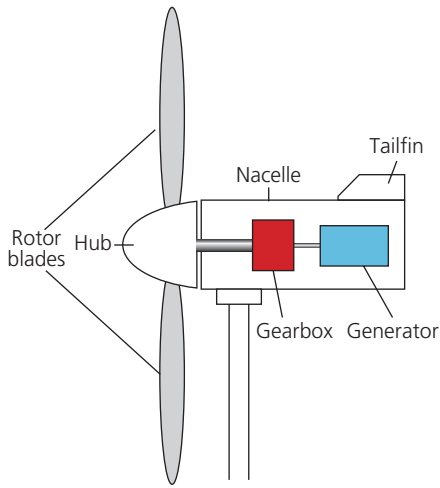

▲ Figure 1.30 Horizontal-axis wind turbine

facing in the correct direction to make the most of the available wind. The gearbox and generator will also be mounted in the horizontal plane.

Vertical-axis wind turbines, of which there are many different designs, will work with wind blowing from any direction and therefore do not require a tailfin. A VAWT, however, does have a gearbox and a generator.

The two types of micro-wind turbines suitable for domestic installation are:

- pole-mounted, free-standing wind turbines
- building-mounted wind turbines, which are generally smaller than pole-mounted turbines.

Micro-wind generation systems fall into two basic categories.

- On-grid (grid-tied): these systems are connected in parallel with the grid supply via an inverter.
- Off-grid: these systems charge batteries to store electricity for later use.

The output from a micro-wind turbine is *wild* alternating current (AC). 'Wild' refers to the fact that the output varies in both voltage and frequency. The output is connected to a system controller, which rectifies the output to DC.

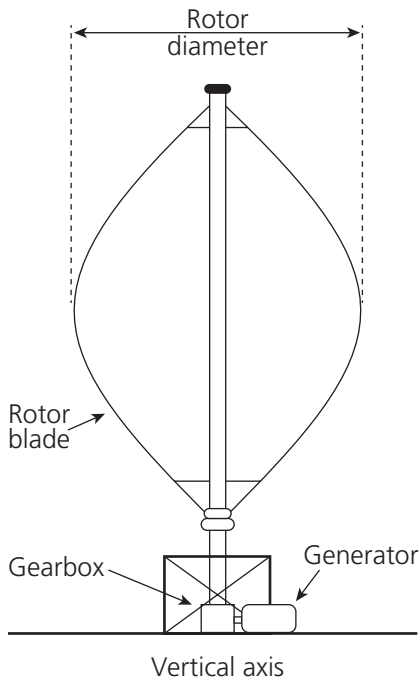

▲ Figure 1.31 Vertical-axis wind turbine

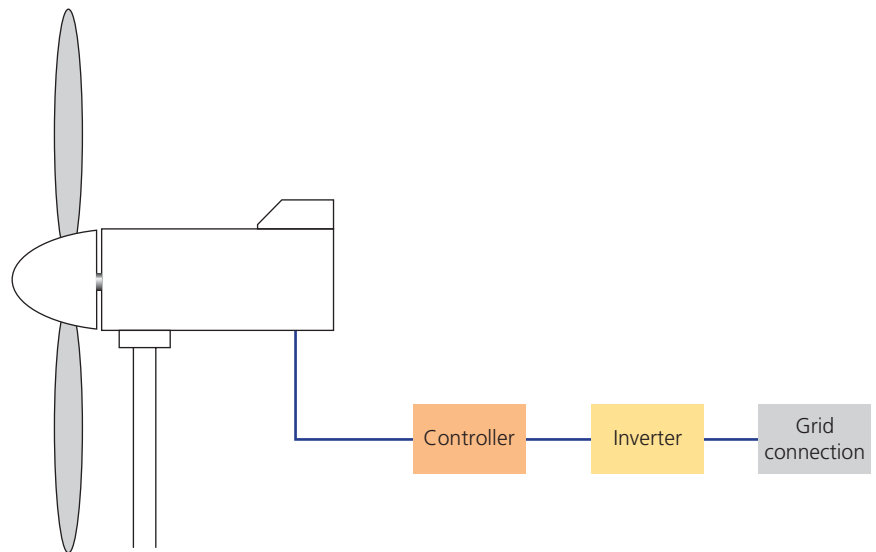

▲ Figure 1.32 Block diagram of an on-grid micro-wind system

In the case of an on-grid system, the DC output from the system controller is connected to an inverter that converts DC to AC at 230 V 50 Hz for connection to the grid supply via a generation meter and the consumer unit.

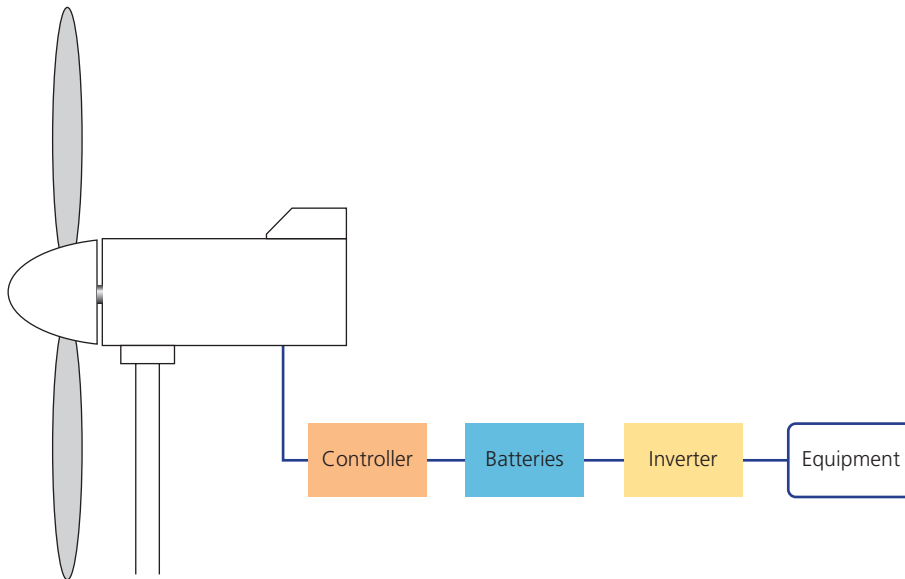

▲ Figure 1.33 Block diagram of an off-grid micro-wind system

With off-grid systems, the output from the controller is used to charge batteries so that the output can be stored for when it is needed. The output from the batteries then feeds an inverter so that 230 V AC equipment can be connected.

Location and building requirements

Several factors need to be taken into account when considering whether or not a location is suitable for the installation of a micro-wind turbine. These include:

- the average wind speed on the site
- obstructions and turbulence
- the height at which the turbine can be mounted
- turbine noise
- turbine vibration
- shadow flicker.

Average wind speed on the site

Wind is not constant, so the average wind speed on a site, measured in metres per second (m/s), is a prime consideration when deciding on a location's suitability for the installation of a micro-wind turbine. Wind speed needs to be a minimum of 5 m/s for a wind turbine to generate electricity. Manufacturers of wind turbines provide power curves for their turbines, which show the output of a turbine at different wind speeds. Most micro-wind turbines will achieve their maximum output when the wind speed is about 10 m/s.

Obstructions and turbulence

For a wind turbine to work efficiently, a smooth flow of air needs to pass across the turbine blades. The ideal location for a wind turbine would be at the top of a gentle slope. As the wind passes up the slope it gains speed, resulting in a higher output from the turbine.

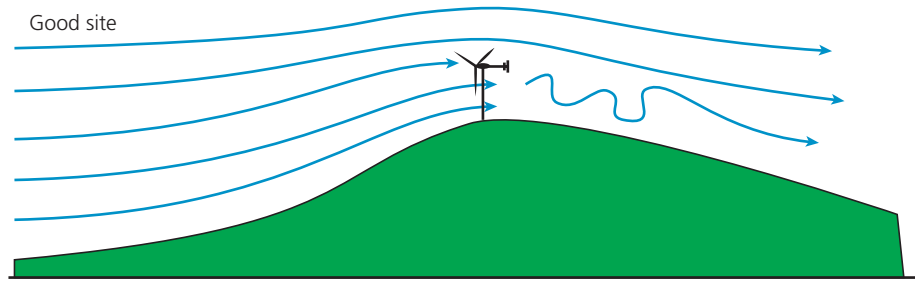

▲ Figure 1.34 A suitable site for a micro-wind turbine

Figure 1.35 illustrates the effect on the wind when a wind turbine is poorly sited. The wind passing over the turbine blades is disturbed and thus the efficiency is reduced.

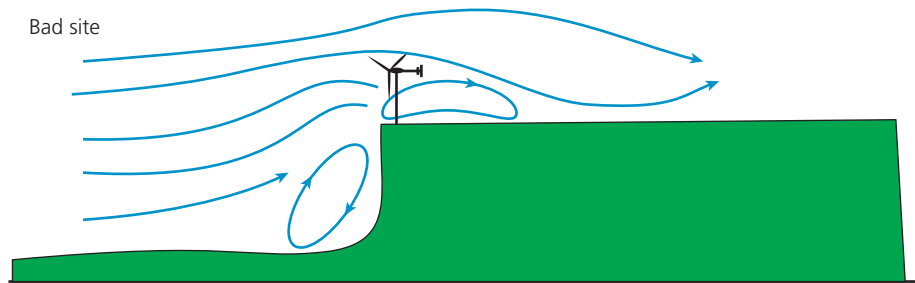

▲ Figure 1.35 An unsuitable site for a micro-wind turbine

Any obstacles, such as trees or tall buildings, will affect the wind passing over the turbine blades. Where an obstacle is upwind of the wind turbine, in the direction of the prevailing wind, the wind turbine should be sited at a minimum distance of ten times the height of the obstacle, away from the obstacle. In the case of an obstacle that is 10 m in height, this would mean that the wind turbine should be sited a minimum of 10×10 m away, which is 100 m from the obstacle.

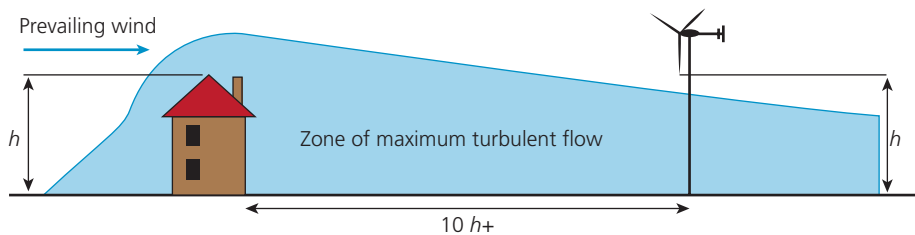

▲ Figure 1.36 Placement of micro-wind turbines to avoid obstacles

INDUSTRY TIP

As a wind turbine has moving parts, consideration needs to be given to access for maintenance.

The height at which the turbine can be mounted

Generally, the higher a wind turbine is mounted, the better. The minimum recommended height is 6–7 m but, ideally, it should be mounted at a height of 9–12 m.

Where an obstacle lies upwind of the turbine, the bottom edge of the blade should be above the height of the obstacle.

Turbine noise

The wind turbine will generate noise when in use, so consideration needs to be given to buildings sited close to the wind turbine.

Turbine vibration

Consideration needs to be given to vibration if the wind turbine is to be mounted on a building. It may be necessary to consult a structural engineer.

Shadow flicker

Shadow flicker is the result of the rotating blades of a turbine passing between a viewer and the Sun. It is important to ensure that shadow flicker does not unduly affect a building sited in the shadow-flicker zone of the wind turbine.

The distance of the shadow-flicker zone from the turbine will be at its greatest when the Sun is at its lowest in the sky.

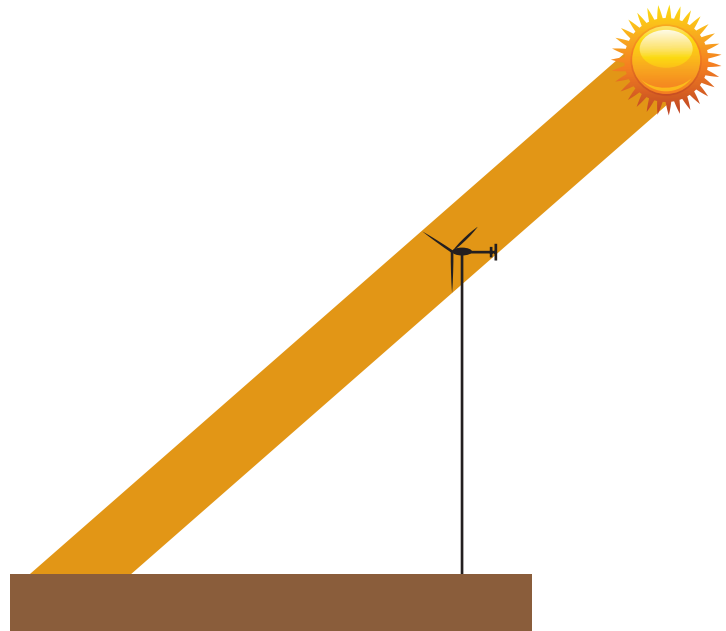

▲ Figure 1.37 The area affected by shadow flicker

Planning permission

While permitted development exists for the installation of wind turbines, it is severely restricted so, for the majority of installations, a planning application will be required.

Permitted development applies where a wind turbine is installed:

- on a detached dwelling house
- on a detached building within the grounds of a dwelling house or block of flats
- as a stand-alone system in the grounds of a dwelling house or block of flats.

It is important to note that permitted development for building-mounted wind turbines only applies to detached premises. It does not apply to semi-detached houses or flats.

Even with detached premises or stand-alone turbines there are criteria to be met.

- The wind turbine must comply with the Microgeneration Certification Scheme (MCS) planning standards or equivalent.
- Only one wind turbine may be installed on the building or within the grounds of the building.
- An air-source heat pump may not be installed on the building or within the grounds of the building.

- The highest part of the wind turbine (normally the blades) must not protrude more than 3 m above the ridge line of the building or be more than 15 m in height.
- The lowest part of the blades of the wind turbine must be a minimum of 5 m from ground level.
- The wind turbine must be a minimum of 5 m from the boundary of the premises.
- The wind turbine cannot be installed on or within:
 - land that is safeguarded land (usually designated for military or aeronautical reasons)
 - a site that is designated as a scheduled monument
 - a listed building
 - the grounds of a listed building
 - land within a national park
 - an area of outstanding natural beauty
 - the Broads (wetlands and inland waterways in Norfolk and Suffolk).
- The wind turbine cannot be installed on the roof or wall of a building that fronts a highway, if that building is within a conservation area.

The following conditions also apply.

- The blades must be made of non-reflective material.
- The wind turbine should be sited so as to minimise its effect on the external appearance of the building.

Compliance with Building Regulations

The Building Regulations applicable to the installation of micro-wind systems are outlined in Table 1.8.

▼ Table 1.8 Building Regulations applicable to micro-wind systems

Part	Title	Relevance
A	Structure	Where equipment and components can put extra load on the structure of the building, or the fabric requires modifications such as chases, the suitability of the structure must be considered.
B	Fire safety	Where holes for cables are made, this may reduce the fire resistance of the building fabric.
C	Site preparation and resistance to contaminates and moisture	Where holes for cables and fixings for the system are made, this may reduce the moisture resistance of the building and allow ingress of water.
E	Resistance to the passage of sound	Where holes for cables are made, this may reduce the soundproof integrity of the building structure.
L	Conservation of fuel and power	Energy efficiency of the system and the building as a whole must be considered.
P	Electrical safety	The installation of electrical controls and components must be considered.

Other regulatory requirements to consider

Other regulatory requirements to consider regarding the installation of micro-wind systems are:

- the requirements of the distribution network operator (for on-grid systems)
- **BS 7671: 2018 (2022)** The IET Wiring Regulations, 18th Edition, including amendments.

The advantages and disadvantages of micro-wind systems

The advantages of micro-wind systems are that they:

- can be very effective on a suitable site as the UK benefits from Atlantic winds
- produce no CO₂ emissions
- produce most energy in the winter, when consumer demand is at its maximum
- can be a very effective technology where mains electricity does not exist.

The disadvantages of micro-wind systems are that:

- initial costs are high
- the requirements of the site are onerous
- planning can be onerous
- performance is variable and dependent on wind availability
- micro-wind turbines cause noise, vibration and shadow flicker.

Micro-hydro

All rivers flow downhill. This movement of water from a higher level to a lower level is a source of free **kinetic energy** that hydro-electric generation harnesses. Water passing across or through a turbine can be used to turn a generator and thus produce electricity. Given the right location, micro-hydro-electric is the most constant and reliable source of all the **microgeneration technologies** and is the most likely of these technologies to meet all the energy needs of the consumer.

As with the other microgeneration technologies, there are two possible system arrangements for micro-hydro schemes: on-grid and off-grid systems.

Working principles

While it is possible to place generators directly into the water stream, it is more likely that the water will be diverted from the main stream or river, through the turbine, and back into the stream or river at a lower level. Apart from the installation work involved with the turbines and generators, there is also a large amount of civil engineering and construction work to be carried out to route the water to where it is needed.

The main components of the water course construction are:

- intake, which is the point where a portion of the river's water is diverted from the main stream
- the canal that connects the intake to the forebay
- the forebay, which holds a reservoir of water that ensures that the penstock is pressurised at all times and allows surges in demand to be catered for
- the penstock, which is pipework taking water from the forebay to the turbines
- the powerhouse, which is the building housing the turbine and the generator
- the tailrace, which is the outlet that takes the water exiting the turbines and returns it to the main stream of the river.

ACTIVITY

Using the internet, research information on the Rampion offshore wind farm. Find out details, such as:

- output power
- cost to construct
- the number of turbines
- location.

KEY TERMS

Kinetic energy: Energy of motion; the movement of an object can do work (energy) on anything it hits or is connected to.

Microgeneration technologies: Small-scale methods of generating electricity, such as solar photovoltaic, wind turbine and hydro.

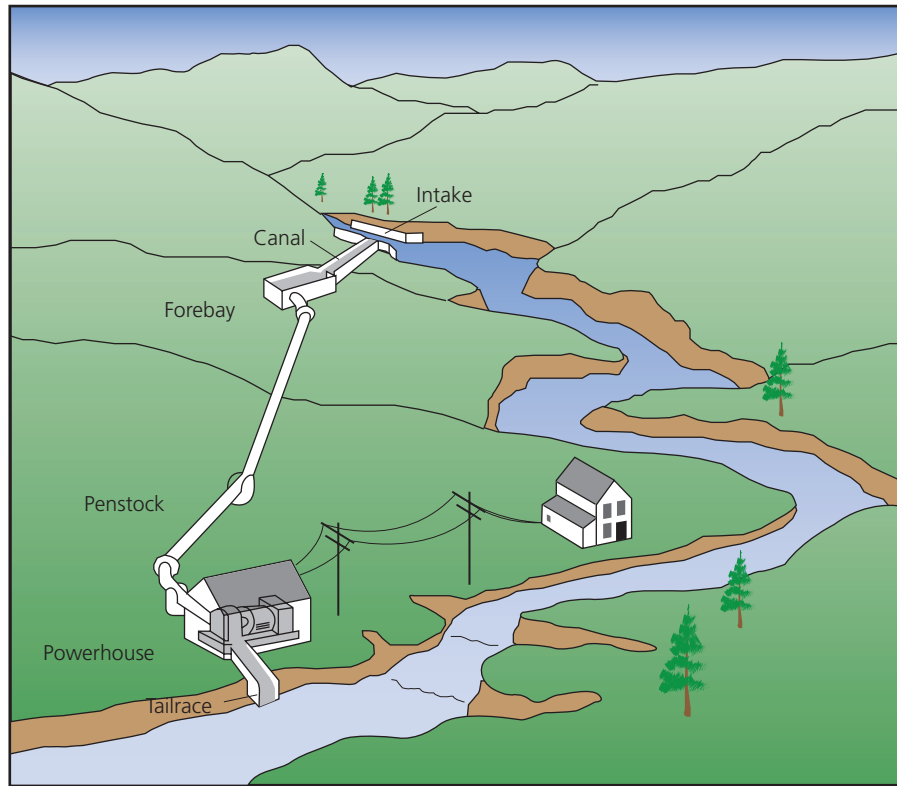

▲ Figure 1.38 The component parts of a micro-hydro system

To ascertain the suitability of the water source for hydro-electric generation, it is necessary to consider the head and the flow of the water source.

Head

The head is the vertical height difference between the proposed inlet position and the proposed outlet. This measurement is known as 'gross head'.

Head height is generally classified as:

- low head, below 10 m
- medium head, 10–50 m
- high head, above 50 m.

Net head

This is used in calculations of potential power generation and takes into account losses due to friction as the water passes through the penstock.

Flow

This is the amount of water flowing through the water course and is measured in cubic metres per second (m^3/s).

Turbines

There are many types of turbine but they fall into two primary design groups: impulse turbines and reaction turbines. Each design group is better suited to a particular type of water supply.

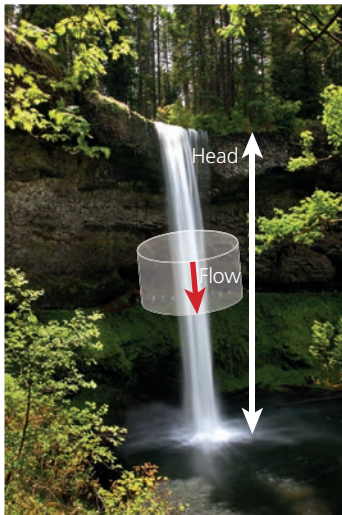

▲ Figure 1.39 The meaning of 'head' and 'flow'

INDUSTRY TIP

There is no absolute definition for each head height classification. The Environment Agency, for example, classifies low head as below 4 m. Some manufacturers specify high head as above 300 m.

Impulse turbines

In impulse turbines, the turbine wheel or runner operates in air, with water jets driving the runner. The water from the penstock is focused on the blades by means of a nozzle. The velocity of the water is increased but the water pressure remains the same, so there is no requirement to enclose the runner in a pressure casing. Impulse turbines are used with high-head water sources. Examples of impulse turbines are given below.

The **Pelton turbine** consists of a wheel with bucket-type vanes set around the rim. The water jet hits the vane and turns the runner. The water gives up most of its energy and falls into a discharge channel below. A multi-jet Pelton turbine is also available. A Pelton turbine is used with medium or high-head water sources.

The **Turgo turbine** is similar to the Pelton but the water jet is designed to hit the runner at an angle and from one side of the turbine. The water enters at one side of the runner and exits at the other, allowing the Turgo turbine to be smaller than the Pelton for the same power output. This type of turbine is used with water sources with medium or high heads of water.

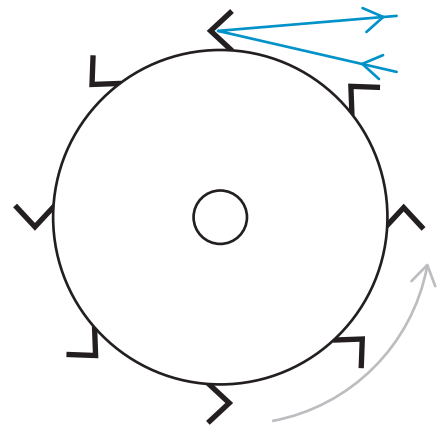

▲ Figure 1.40 Impulse turbine

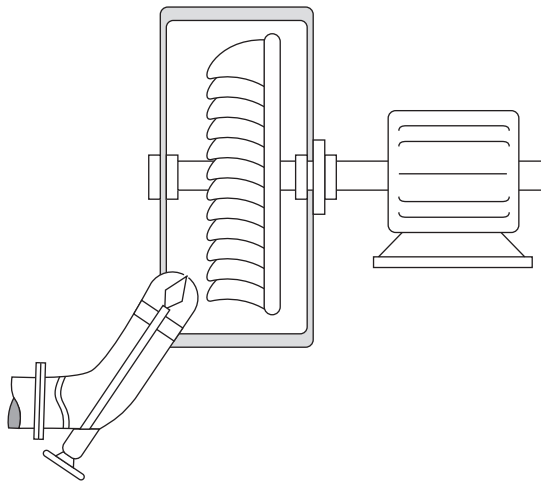

▲ Figure 1.41 Turgo turbine

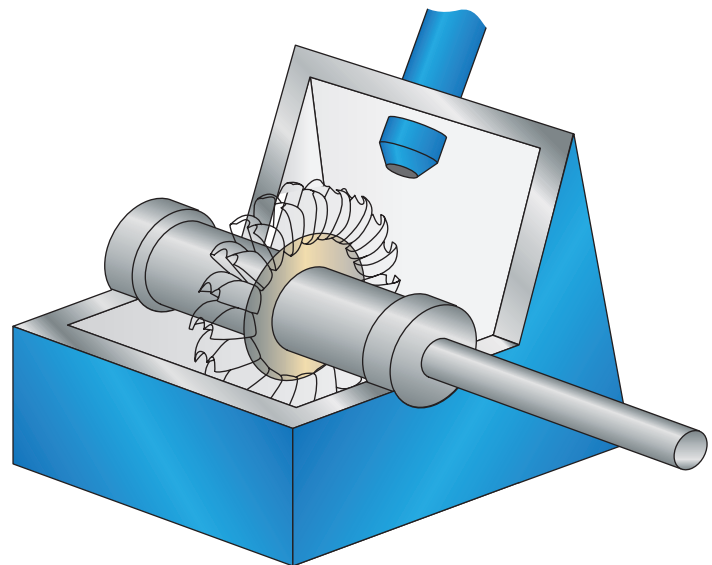

▲ Figure 1.42 Impulse turbine

With the **cross-flow** or **Banki** type of turbine, the runner consists of two end-plates with slats, set at an angle, joining the two discs – much like a water wheel. Water passes through the slats, turning the runner and then exiting from below. This type of turbine is used with water sources with low or medium heads of water.

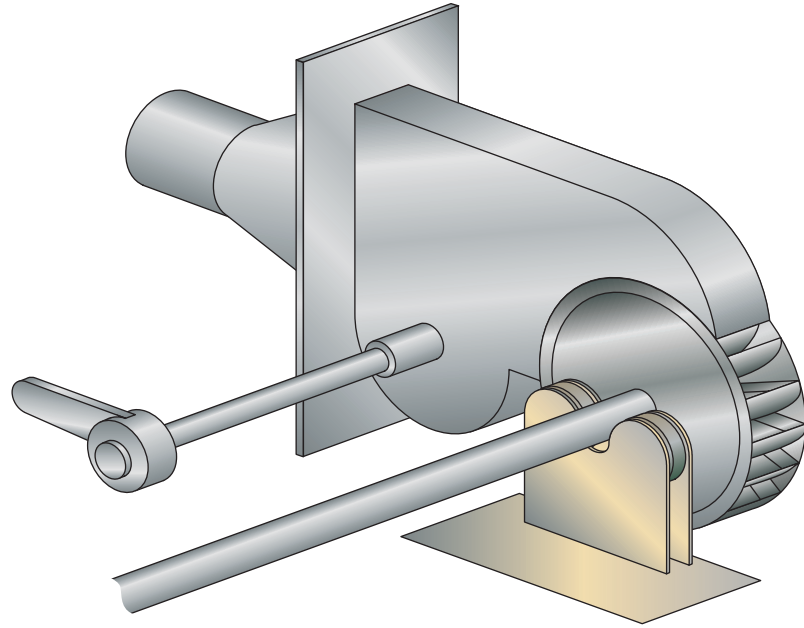

▲ Figure 1.43 Cross-flow or Banki turbine

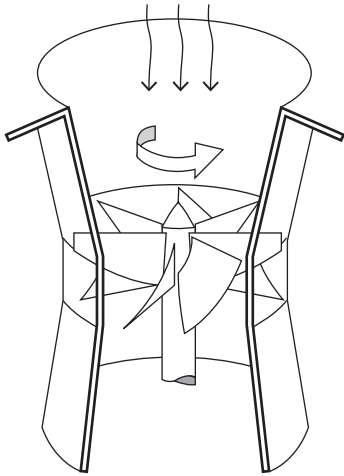

▲ Figure 1.44 Reaction turbine

Reaction turbines

In a reaction turbine, the runners are fully immersed in the water and enclosed in a pressure casing. Water passes through the turbine, causing the runner blades to turn or react.

Examples of reaction turbines are described below.

In a **Francis wheel turbine**, water enters the turbine housing and passes through the runner, causing it to turn. This type of turbine is used with water sources with low heads of water.

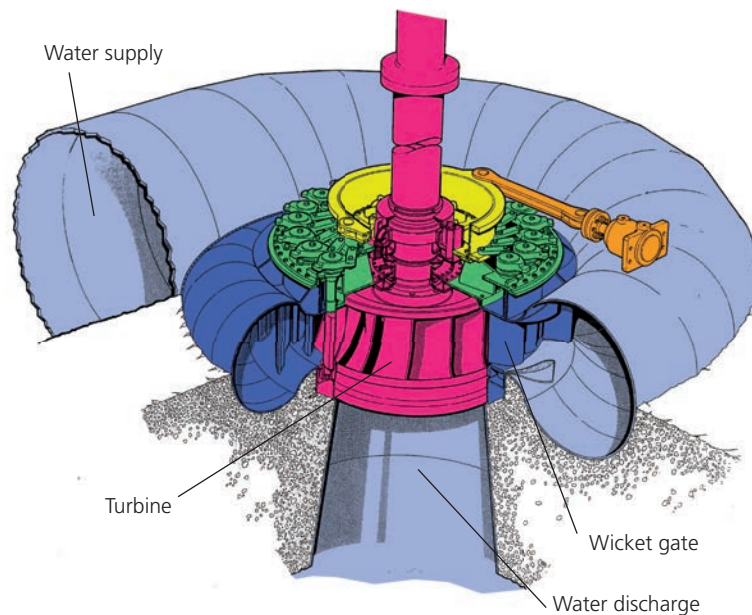

▲ Figure 1.45 Francis wheel turbine

Kaplan (or propeller) turbines work like a boat propeller in reverse. Water passing the angled blades turns the runner. This type of turbine is used with water sources with low heads of water.

The Archimedes' screw consists of a helical screw thread, which was originally designed so that turning the screw – usually by hand – would draw water up the thread to a higher level. In the case of hydro-electric turbines, a **reverse Archimedes' screw** is used: water flows down the screw, hence reverse, turning the screw, which is connected to the generator. This type of turbine is particularly suited to low-head operations but its major feature is that, due to its design, it is 'fish-friendly' and fish are able to pass through it. For this reason, the reverse Archimedes' screw may be the only option if a hydro-electric generator is to be fitted on a river that is environmentally sensitive.

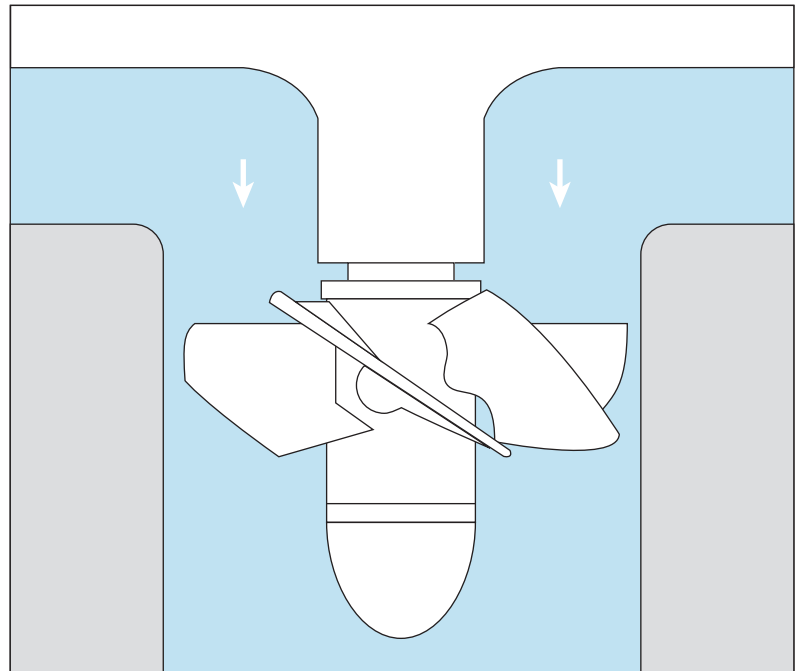

▲ Figure 1.46 Kaplan or propeller turbine

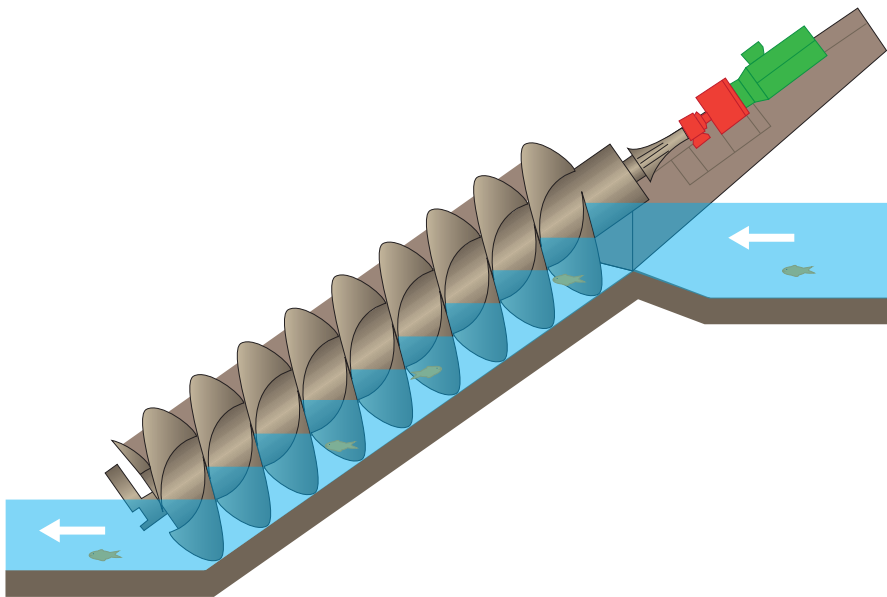

▲ Figure 1.47 Reverse Archimedes' screw

Location and building requirements

The following factors should be taken into account when considering the installation of a micro-hydro turbine.

The location will require a suitable water source with:

- a minimum head of 1.5 m
- a minimum flow rate of 100 litres/second.

The water source should not be subject to seasonal variation that will take the water supply outside of the above parameters.

The location has to be suitable, to allow for construction of:

- the water inlet
- the turbine/generator building
- the water outlet or tail race.

Planning permission

Planning permission will be required.

A micro-hydro scheme will have an impact on:

- the landscape and visual amenity
- nature conservation
- the water regime.

VALUES AND BEHAVIOURS

The planning application for a micro-hydro scheme will need to be accompanied by an environmental statement detailing any environmental impact and what measures will be taken to minimise these.

An environmental statement typically covers:

- flora and fauna
- noise levels
- traffic
- land use
- archaeology
- recreation
- landscape
- air and water quality.

Compliance with Building Regulations

The Building Regulations applicable to the installation of micro-hydro systems are outlined in Table 1.9.

▼ Table 1.9 Building Regulations applicable to micro-hydro systems

Part	Title	Relevance
A	Structure	Where equipment and components can put extra load on the structure of the building, or the fabric requires modifications such as chases, the suitability of the structure must be considered.
B	Fire safety	Where holes for pipes or cables are made, this may reduce the fire resistance of the building fabric.
C	Site preparation and resistance to contaminates and moisture	Where holes for pipes, cables and fixings for the system are made, this may reduce the moisture resistance of the building and allow ingress of water.
E	Resistance to the passage of sound	Where holes for pipes or cables are made, this may reduce the soundproof integrity of the building structure.
P	Electrical safety	The installation of electrical controls and components must be considered.

Other regulatory requirements to consider

Other regulatory requirements to consider regarding the installation of micro-hydro systems are:

- **BS 7671: 2018 (2022)** The IET Wiring Regulations, 18th Edition, including amendments
- G98 Requirements for Grid-tied Systems
- Microgeneration Certification Scheme (MSC) requirements
- Environment Agency requirements.

In England and Wales, all waterways are controlled by the Environment Agency. To remove water from these waterways, even though it may be returned – as in the case of a hydro-electric system – will usually require permission and a licence.

There are three types of licence that may apply to a hydro-electric system.

- An **abstraction licence** will be required if water is diverted away from the main water course. The major concern will be the impact that the project has on fish migration, as most turbines are not fish-friendly. This requirement may affect the choice of turbine (see reverse Archimedes' screw, page 41). It may mean that fish screens are necessary over water inlets or, where the turbine is in the main channel of water, a fish pass around the turbine may need to be constructed.
- An impoundment is any construction that changes the flow of water. An **impoundment licence** will be required if changes or additions are made to sluices, weirs and so on that control the flow within the main stream of water.
- A **land drainage licence** will be required for any changes made to the main channel of water.

An environment site audit (ESA) will be required as part of the initial assessment process. An ESA covers:

- water resources
- conservation
- chemical and physical water quality
- biological water quality
- fisheries
- managing flood risk
- navigation of the waterway.

The advantages and disadvantages of micro-hydro systems

The advantages of micro-hydro systems are that:

- there are no on-site carbon emissions
- large amounts of electricity are output, usually more than required for a single dwelling; the surplus can be sold
- there is a reasonable payback period
- they are excellent systems where no mains electricity exists
- they are not dependent on weather conditions or building orientation.

The disadvantages of micro-hydro systems are that:

- a high head or fast flow of water is required on the property
- planning permission is required, which can be onerous
- permission from the Environment Agency is required for water extraction
- strengthening of the grid may be required for grid-tied systems
- initial costs are high.

MICRO-COMBINED HEAT AND POWER

In micro-combined heat and power (mCHP) technologies, also referred to as co-generation energy technologies, a fuel source is used to satisfy the demand for heat but, at the same time, generates electricity that can either be used or sold back to the supplier. Currently, mCHP units used in domestic dwellings are powered by means of natural gas or liquid propane gas (LPG), but could be fuelled by using biomass fuels. Figure 1.48 represents, from left to right, an old, inefficient gas boiler, a modern condensing boiler and an mCHP unit.

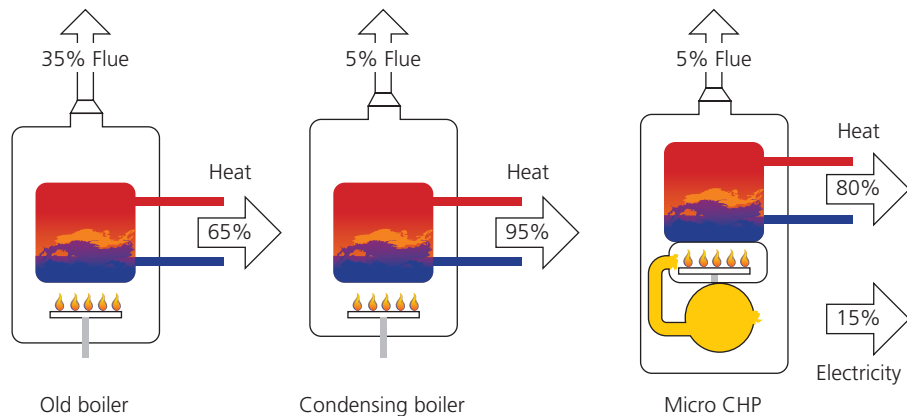

▲ Figure 1.48 The efficiency of different boilers

Working principles

With the old, inefficient gas boiler, 65% of the input energy is used to provide heating for the premises; 35% is lost up the flue. With the modern condensing boiler, this lost heat is reused so that the output to the heating is 95%. The mCHP unit will achieve the same efficiencies as the modern condensing boiler but 80% of the input is used to provide heat and 15% is used to power a generator.

VALUES AND BEHAVIOURS

Reducing the cost as well as the environmental impact of any installation is important.

There are obvious savings to be made in replacing an old, inefficient boiler with an mCHP unit.

On a unit-by-unit comparison, gas is cheaper than electricity, so any electricity generated by using gas means a proportionally greater financial saving over using electricity.

In addition to this saving, locally generated power reduces transmission losses, and consequently creates less CO₂, than if the electricity were generated at a power station some distance away.

This type of generation, using an mCHP unit, is known as 'heat-led'; the primary function of the unit is to provide space heating, while the generation of electricity is secondary. The more heat that is produced, the more electricity is generated. The unit only generates electricity when there is a demand for heating. Most domestic mCHP units will generate between 1 kW and 1.5 kW of electricity. Micro-combined heat and power is a carbon-reduction technology rather than a carbon-free technology.

INDUSTRY TIP

Carbon-reduction technologies (CRTs) are technologies that reduce but do not eliminate the need for a fuel source. They can include combined heat and power systems, which use fuel more efficiently than conventional boilers or power generators. In contrast, carbon-free technologies use natural resources, such as wind. Carbon-reduction technologies also include low-energy, current-using equipment, such as LED lighting, because these technologies reduce the need for electricity, thus reducing carbon.

Combined heat and power (CHP) units have been available for some years but it is only recently that domestic versions have become available. Domestic versions are usually gas-fired and use a Stirling engine to produce electricity, though other fuel sources, and types of generator combinations, are available.

The key components of an mCHP unit are:

- an engine burner
- a Stirling engine generator
- a supplementary burner
- a heat exchanger.

When there is demand for heat, the engine burner works to:

- fire and start the Stirling engine generator
- produce about 25% of the full heat output of the unit

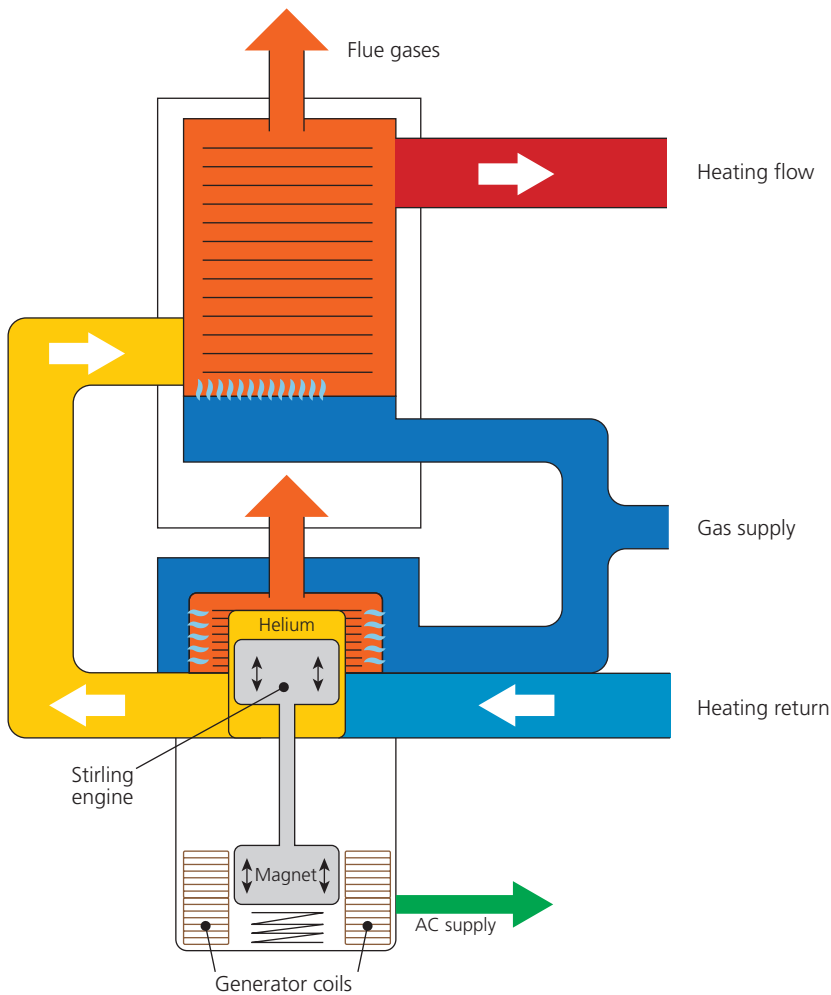

▲ Figure 1.49 Component parts of a micro-CHP boiler

- preheat the heating-system return water before passing it to the main heat exchanger
- pass the hot flue gases across the heat exchanger to heat the heating-system water further.

If there is greater demand for heat than is being supplied by the engine burner, then the supplementary burner operates to meet this demand.

How the Stirling engine generator works

The first Stirling engine was invented by Robert Stirling in 1816. A Stirling engine is very different from an internal combustion engine; it uses the expansion and contraction of internal gases, caused by changes in temperature, to drive a piston. The gases within the engine do not leave the engine and no explosive combustion takes place, so the Stirling engine is very quiet when in use.

In the case of a Stirling engine used in an mCHP unit, the gas contained within the engine is helium.

- When the engine burner fires, the helium expands, forcing the piston downwards.
- The return water from the heating system passing across the engine cools the gas, causing it to contract.
- A spring arrangement within the engine returns the piston to the top of the cylinder and the process starts all over again.
- The piston is used to drive a magnet up and down between coils of wire, generating an electromotive force (emf) in the coils.

Connection of the mCHP unit to the supply

The preferred method for connecting an mCHP unit to the supply is via a dedicated circuit directly from the consumer unit. This method allows for easy isolation of the generator from the incoming supply.

Location and building requirements

For mCHP to be viable, the building should have a high demand for space heating. The larger the property, the greater the carbon savings. A building that is well insulated will not usually be suitable for mCHP, because a well-insulated building is unlikely to have a high demand for space heating.

If an mCHP unit is fitted to a building that is either too small or well insulated, the demand for heat will be low and the mCHP unit will cycle on and off, resulting in inefficient operation.

Planning permission

Planning permission will not normally be required for the installation of an mCHP unit in a domestic dwelling if the entire work is confined to the inside of the building. If the installation requires an external flue to be installed, this will normally be classed as permitted development as long as the flue to the rear or side elevation does not extend more than 1 m above the highest part of the roof.

Listed buildings or buildings in a designated area

Check with the local planning authority regarding both internal work and external flues.

Buildings in a conservation area or in a World Heritage Site

Flues should not be fitted on the principal or side elevation if they would be visible from a highway.

If the project includes the construction of buildings for fuel storage or to house the mCHP unit, then the same planning requirements will apply as for extensions and garden outbuildings.

Compliance with Building Regulations

The Building Regulations applicable to the installation of micro-combined heat and power systems are outlined in Table 1.10.

▼ Table 1.10 Building Regulations applicable to micro-combined heat and power systems

Part	Title	Relevance
A	Structure	Where equipment and components can put extra load on the structure of the building, or the fabric requires modifications such as chases, the suitability of the structure must be considered.
B	Fire safety	Where holes for pipes or cables are made, this may reduce the fire resistance of the building fabric.
C	Site preparation and resistance to contaminants and moisture	Where holes for pipes, cables and fixings for the system are made, this may reduce the moisture resistance of the building and allow ingress of water.
E	Resistance to the passage of sound	Where holes for pipes or cables are made, this may reduce the soundproof integrity of the building structure.
G	Sanitation, hot-water safety and water efficiency	Hot-water safety and water efficiency must be considered.
J	Combustion appliances and fuel-storage systems	Biomass boilers produce heat and therefore must be installed correctly.
L	Conservation of fuel and power	Energy efficiency of the system and the building as a whole must be considered.
P	Electrical safety	The installation of electrical controls and components must be considered.

Other regulatory requirements to consider

Other regulatory requirements to consider regarding the installation of an mCHP unit are that:

- gas regulations will apply to the installation
- the gas installation work will need to be carried out by an operative registered on the Gas Safe register
- Water Regulations (WRAS) will apply to the water systems
- **BS 7671: 2018 (2022)** The IET Wiring Regulations, 18th Edition, including amendments, will apply to the installation of control wiring and the wiring associated with the connection of the mCHP electrical generation output
- G98 requirements will apply to the connection of the generator, although mCHP units do have a number of exemptions
- Microgeneration Certification Scheme (MSC) requirements will apply.

The advantages and disadvantages of micro-combined heat and power systems

The advantages of mCHP systems are that:

- the ability to generate electricity is not dependent on building direction or weather conditions
- the system generates electricity while there is demand for heat
- they save carbon over centrally generated electricity
- they reduce the building's carbon footprint.

The disadvantages of mCHP systems are that:

- the initial cost is high compared with an efficient gas boiler
- they are unsuitable for properties with low demand for heat – small or very well-insulated properties
- there is limited capacity for the generation of electricity.

ACTIVITY

Visit the Met Office website.

Navigate the site to compare the annual rainfall for the following four locations, to get an idea of the rainiest and driest places in the UK:

- Walney Island, Cumbria
- Shoreham, Sussex
- Sennybridge, South Wales
- Lowestoft, East Anglia.

WATER CONSERVATION TECHNOLOGIES

Many people regard the climate of the UK as wet. It is a common perception that the UK has a lot of rain and, in some locations, this is true, especially towards the west, where average annual rainfall exceeds 1000 mm. Along the east coast, however, the average annual rainfall is less than half of this.

The population of the UK is expanding and the demands placed on the water supply systems are ever increasing. Hose-pipe bans in many parts of the UK are a regular feature of the summer months. In the UK, unlike in many other European countries, the water supplied is suitable for consumption straight from the tap, although we use water not only for drinking, but also for bathing, washing clothes, watering gardens and washing cars.

VALUES AND BEHAVIOURS

Even in the UK, clean, fresh water is a limited resource. With growing demand, the pressure on this vital resource is increasing. Water conservation is one way of ensuring that demand does not outstrip supply.

The two methods of water conservation covered in this chapter are:

- rainwater harvesting
- reuse of greywater.

Water conservation is one way of reducing the cost of water bills. Whether a water bill is based on the amount of water used (metered) or a fixed rate (unmeasured), it will contain two charges:

- charges for fresh water supplied
- charges for sewage or waste water taken away.

The amount of water taken away, which includes surface water (rainwater), is assumed to be 95% of the water supplied.

By conserving water, the waste-water charge, as well as the charge for fresh water supplied, can be reduced. Water conservation also helps to relieve the pressure on a vital resource.

Within the average home, the amount of water used for flushing toilets is estimated at 28.1% of an average household consumption, according to the Energy Saving Trust, and there are obvious opportunities elsewhere for saving water. The technologies covered in this chapter are not concerned with reducing carbon directly or with making financial savings but are solutions for reducing consumption of this valuable resource.

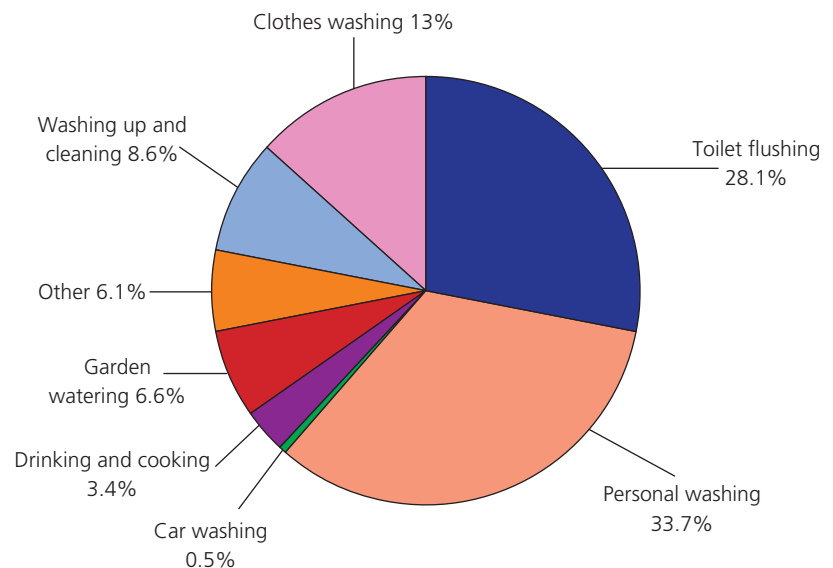

▲ Figure 1.50 How water is used

Rainwater harvesting

Rainwater harvesting refers to the process of capturing and storing rainwater from the surface it falls on, rather than letting it run off into drains or allowing it to evaporate. Reusing rainwater can result in sizeable reductions in **wholesome water** usage and thus monetary savings, as well as indirect carbon reductions.

If harvested rainwater is filtered, stored correctly and does not remain in storage tanks for an excessive period of time, it can be used for:

- flushing toilets
- washing vehicles
- watering the garden
- supplying a washing machine.

KEY TERMS

Rainwater: Water captured from gutters and downpipes.

Wholesome water: Water that is palatable and suitable for human consumption; the water that is obtained from the utility company supply and is also known as 'potable' and 'white water'.

INDUSTRY TIP

For details on fluid categories, research Schedule 1 of the Water Supply (Water Fittings) Regulations 1999.

Harvested rainwater *cannot* be used for:

- drinking water
- washing dishes
- washing and preparing food
- personal hygiene, i.e. washing, bathing or showering.

Rainwater is classified as 'fluid category 5' risk, which is the highest risk category.

Working principles

The process of reusing rainwater involves:

- collection
- filtration
- storage
- reuse.

HEALTH AND SAFETY

Water collected from roofs covered in asbestos, copper, lead or bitumen may not be suitable for reuse and may pose a health risk. It may also result in discolouration of the water or odour problems. Water collected from hard standings, such as driveways, may be contaminated with oil or faecal matter.

The collection or capture of rainwater

Rainwater can be captured from roofs or hard standings. In the case of roofs, the water is captured by means of gutters and flows to the water-harvesting tank via the property's rainwater downpipes. The amount of water that can be collected will be governed by:

- the size of the capture area
- the annual rainfall in the area.

Not all of the water that falls on the surface can be captured. During periods of very heavy rainfall, water may overflow gutters or merely bounce off the roof surface and avoid the guttering system completely.

Filtration

As the rainwater passes from the rainwater-capture system to the storage tanks, it passes through an in-line filter to remove debris, such as leaves. The efficiency of this filter will determine how much of the captured water ends up in the storage tank. Manufacturers usually quote figures in excess of 90% efficiency.

Storage of rainwater

Rainwater storage tanks can be either above-ground or below-ground types and can vary in size, from a small tank next to a house, to a buried tank that is able to hold many thousands of litres of water. Below-ground tanks will require excavation works, while above-ground tanks will need a suitably sized space to accommodate them. Whichever type of tank is used, it will need to be protected against frost, heat from direct sunlight and contamination.

The size of the tank will be determined by the rainwater available and the annual demand. It is common practice to base the size of a tank on 5% of the annual rainwater supply or the anticipated annual demand. A submersible pump is used to transport water from the storage tank to the point of demand.

The tank will incorporate an overflow pipe connected to the drainage system of the property, for times when the harvested rainwater exceeds the capacity of the storage tank.

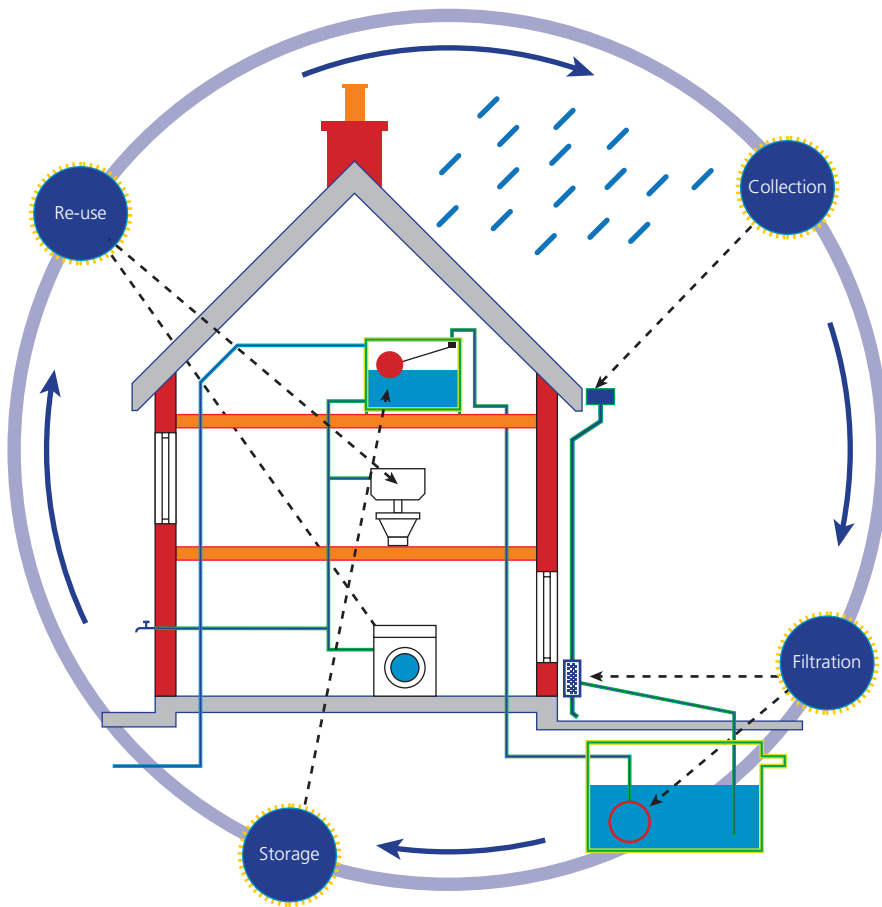

▲ Figure 1.51 Rainwater-harvesting cycle

Reuse of stored rainwater

Two system options are available for the reuse of rainwater that is collected and stored: indirect and direct distribution.

With indirect distribution systems, water is pumped from the storage tank to a supplementary storage tank or header tank located within the premises. This, in turn, feeds the water outlets via pipework separated from the wholesome water supply pipes.

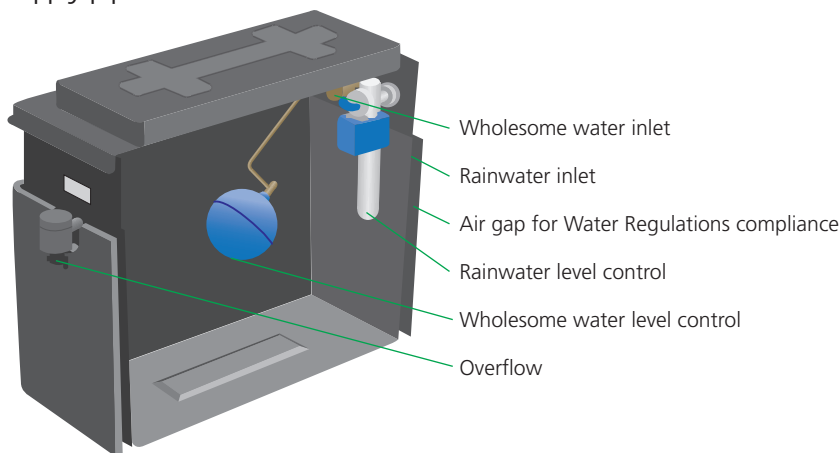

▲ Figure 1.52 Header tank with backflow protection

The header tank will incorporate a backflow prevention air gap to meet the Water Regulations. The arrangement of water control and overflow pipes will ensure that the air gap is maintained. The rainwater level control connects to a control unit that operates the submersible pump, so that water is drawn from the main storage tank when required. At times when there is not enough rainwater to meet the demand, fresh water is introduced into the system via the wholesome water inlet, which is controlled by means of the wholesome water level control.

In direct distribution systems, the control unit pumps rainwater directly to the outlets on demand. At times of low rainwater availability, the control unit will provide water from the wholesome supply to the outlets. The backflow prevention methods to meet the requirements of the Water Regulations will be incorporated into the control unit. This type of system uses more energy than the indirect distribution system.

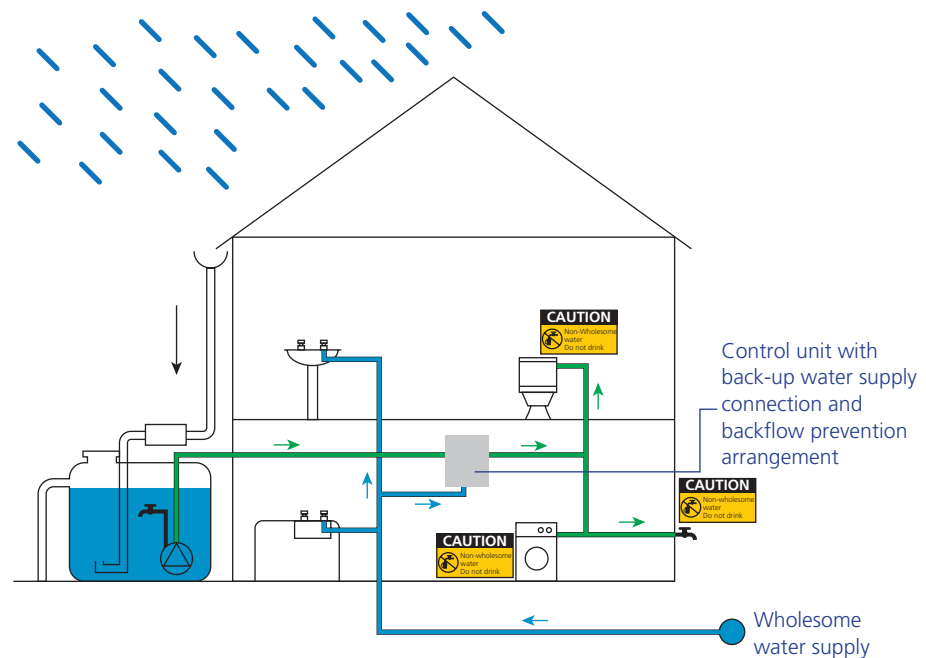

▲ Figure 1.53 Rainwater-harvesting pipework

Location and building requirements

The following points should be taken into account when considering the installation of a rainwater-harvesting system.

- Is there a suitable supply of rainwater to meet the demand? This is determined by the annual rainfall and the amount of water used by the occupants of the building.
- A suitable supply of wholesome water will be required to provide back-up at times of drought.
- For above-ground storage tanks, the chosen location must reduce the risk of freezing, or the warming effects of sunlight, which may encourage algal growth.
- For below-ground tanks, consideration will need to be given to access for excavation equipment.

Planning permission

In principle, planning permission is not normally required for the installation of a rainwater-harvesting system if it does not alter the outside appearance of the property. It is, however, always worth enquiring with the local authority, especially if the system is installed above ground, if the building is in a designated area or if the building is listed.

Compliance with Building Regulations

The Building Regulations applicable to the installation of rainwater-harvesting systems are outlined in Table 1.11.

▼ Table 1.11 Building Regulations applicable to rainwater-harvesting systems

Part	Title	Relevance
A	Structure	Where equipment and components can put extra load on the structure of the building, or the fabric requires modifications such as chases, the suitability of the structure must be considered.
B	Fire safety	Where holes for pipes or cables are made, this may reduce the fire resistance of the building fabric.
C	Site preparation and resistance to contaminants and moisture	Where holes for pipes, cables and fixings for the system are made, this may reduce the moisture resistance of the building and allow ingress of water.
E	Resistance to the passage of sound	Where holes for pipes or cables have been made, this may reduce the soundproof integrity of the building structure.
G	Sanitation, hot-water safety and water efficiency	Hot-water safety and water efficiency must be considered.
H	Drainage and waste disposal	Where gutters and rainwater pipes are connected to the system.
P	Electrical safety	The installation of electrical controls and components must be considered.

Other regulatory requirements to consider

The Water Supply (Water Fittings) Regulations 1999 apply to rainwater-harvesting systems. The key area of concern will be the avoidance of cross-contamination between rainwater and wholesome water. This is known as 'backflow prevention' and, as rainwater is classified as a category 5 risk, the usual method of backflow prevention is through use of a type AA air gap between the wholesome water and the rainwater.

Any pipework used to supply outlets with rainwater will need to be labelled to distinguish it from pipework for wholesome water. Outlets will also need to be labelled to indicate that the water supplied is not suitable for drinking.

KEY FACTS

BS 7671: 2018 (2022) The IET Wiring Regulations, 18th Edition, including amendments, will apply to the installation of supplies and control systems for a rainwater-harvesting system.

BS EN 16941-1: 2018 On-site Non-potable Water Systems; Systems for the Use of Rainwater also applies to these systems.



▲ Figure 1.54 Pipework labels that must be fitted

KEY TERM

Greywater: Waste water from wash basins, showers, baths, kitchen sinks and washing machines.

The advantages and disadvantages of rainwater-harvesting systems

The advantages of rainwater-harvesting systems are that:

- there is a reduction in the use of wholesome water
- the cost of water bills is reduced if the supply is metered
- the water does not require any further treatment before use
- they are less complicated than **greywater** reuse systems.

The disadvantages of rainwater-harvesting systems are that:

- the quantity of available water is limited by roof area, and demand for water may not be met during dry periods
- initial costs are high
- a water meter should be fitted.

Reuse of greywater

Greywater gets its name from its cloudy, grey appearance. Capturing and reusing greywater for permitted uses reduces the consumption of wholesome (drinking) water.

Greywater collected from wash basins, showers and baths will often be contaminated with human intestinal bacteria and viruses, as well as organic material, such as skin particles and hair. As well as these contaminants, it will also contain soap, detergents and cosmetic products, which are ideal nutrients for the

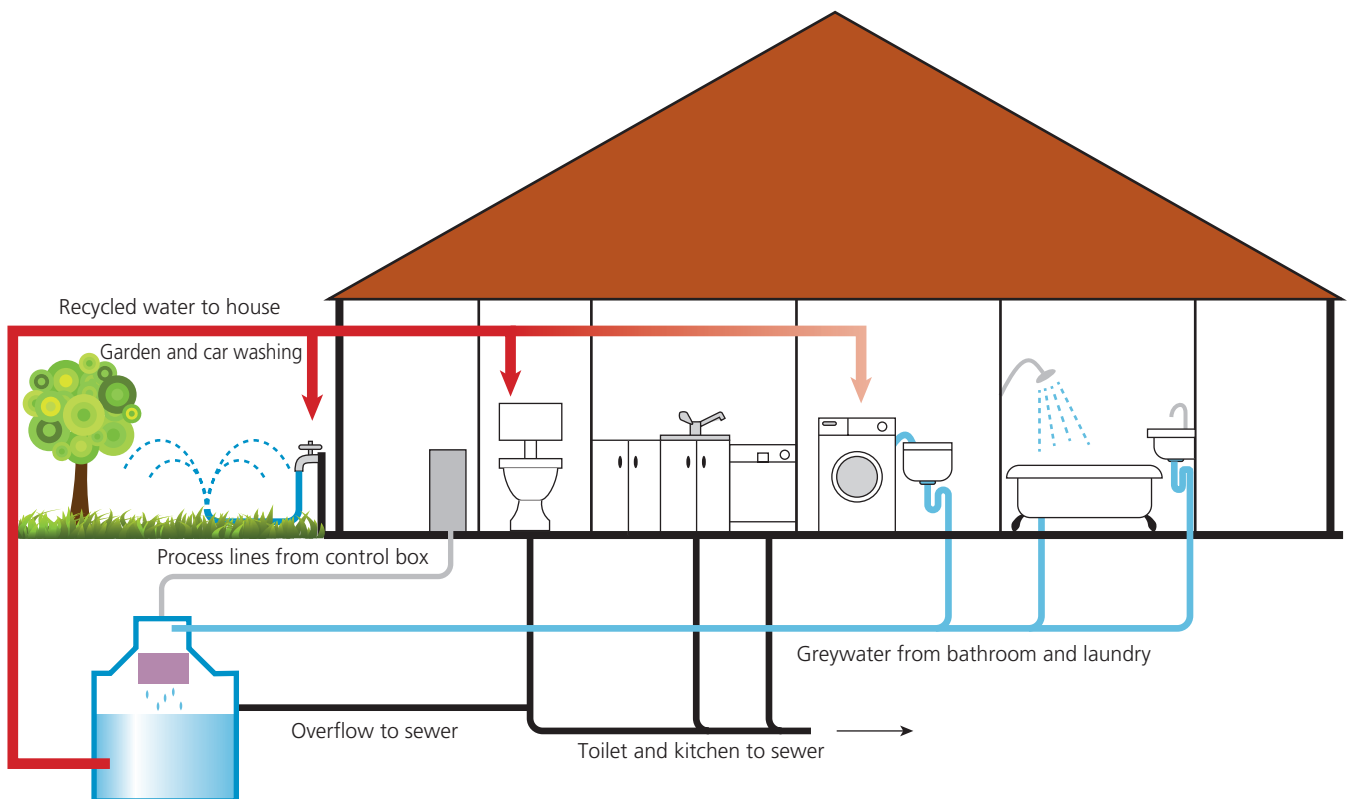

▲ Figure 1.55 Greywater reuse system

growth of bacteria. Add to this the relatively high temperature of the greywater, and the ideal conditions exist to encourage the growth of bacteria.

Untreated greywater deteriorates rapidly when stored, so all systems that store greywater will need to incorporate an appropriate level of treatment.

If greywater is filtered and stored correctly, then it can be used for:

- flushing toilets
- washing vehicles
- watering gardens
- washing clothes (after additional processing).

Greywater *cannot* be used for:

- drinking
- washing dishes
- washing and preparing food
- personal hygiene – washing, bathing or showering.

Working principles

Several types of greywater reuse system exist but, apart from the direct reuse system, they all have similar common features. These are:

- a tank for storing the treated water
- a pump
- a distribution system for moving the water from storage to where it is to be used
- some form of treatment.

Direct reuse system

With a direct reuse system, greywater is collected from appliances and reused without treatment or storage. The greywater can be used for such tasks as watering the garden; even so, it is not considered suitable for watering fruit or vegetable crops.

Short-retention system

With a short-retention system, greywater from baths and showers is collected in a cleaning tank. Here, the greywater is treated, by means such as surface skimming, to remove debris, such as soap, hair and foam. Heavier particles settle to the bottom of the tank, where they are flushed away as waste. The remaining water is then transferred to a storage tank, ready for use.

The storage tank is usually relatively small, at around 100 litres, which is enough for 18–20 toilet flushes. If the water is not used within a short time, generally 24 hours, the stored greywater is purged, the system is cleaned and a small amount of fresh water is introduced to allow toilet flushing. This avoids the greywater deteriorating and beginning to smell at times when the premises are unoccupied for a long period of time.

A short-retention system can result in water savings of 30%. It is ideal for installation in a new-build project but is more difficult to retrofit. The system is usually fitted in the same room as the source of the greywater.

HEALTH AND SAFETY

Greywater is classified as fluid category 5 risk (the highest) under the Water Supply (Water Fittings) Regulations 1999.

Greywater can pose a serious health risk, owing to its potential pathogen content.

Physical and chemical system

A physical and chemical system uses a filter to remove debris from the collected water (physical cleaning). After the greywater has been filtered, chemical disinfectants, such as chlorine or bromine, are added to inhibit the growth of bacteria during storage.

Biomechanical system

This type of system is the most advanced of the greywater reuse systems, using both biological and physical methods to treat the collected greywater. It has an indoor unit, about the size of a large refrigerator. The treatment process is as follows.

- Greywater enters the system and passes through a filtering unit where particles, such as hair and textiles debris, are filtered out. The filtering unit is electronically controlled to provide automatic flushing of the filter.
- Water enters a main recycling chamber, where organic matter is decomposed by biocultures.
- The water remains in this chamber for three hours before being pumped to the secondary recycling chamber for further biological treatment.
- Biological sediment settles to the bottom of each chamber, where it is sucked out and transferred to a drain.
- After a further three hours, the water passes through a UV filter to a final storage chamber, where it is ready for use.
- When there is demand for the treated water, this is pumped to the point of demand.
- At times when the availability of treated water is low, fresh water can be introduced to the system in the final chamber.

Water from this unit can be used for washing clothes as well as for the other tasks previously stated.

Location and building requirements

The following factors should be taken into account when considering the installation of a greywater reuse system.

- There needs to be a suitable supply of greywater to meet the demand. Premises with a low volume of greywater are not suitable for a greywater reuse system.
- Suitability of the location and the availability of space to store enough greywater to meet the demand of the premises must be assessed.
- Storage tanks need to be located away from heat, including direct sunlight, to avoid the growth of algae. They need to be located so that they are not liable to freezing in cold weather.
- There needs to be a wholesome water supply.
- Where greywater tanks are retrofitted, access for excavation equipment will need to be considered.
- A water meter will need to be fitted on the water supply to maximise the benefits.

Planning permission

In principle, planning permission is not normally required for the installation of a greywater reuse system if it does not alter the outside appearance of the property. It is, however, always worth enquiring with the local authority, especially if the system is installed above ground, if the building is in a designated area or if the building is listed.

If a building is required to house the greywater storage system, then a planning application will need to be submitted.

Compliance with Building Regulations

The Building Regulations applicable to the installation of greywater reuse systems are outlined in Table 1.12.

▼ Table 1.12 Building Regulations applicable to greywater reuse systems

Part	Title	Relevance
A	Structure	Where equipment and components can put extra load on the structure of the building, or the fabric requires modifications such as chases, the suitability of the structure must be considered.
B	Fire safety	Where holes for pipes or cables are made, this may reduce the fire resistance of the building fabric.
C	Site preparation and resistance to contaminants and moisture	Where holes for pipes, cables and fixings for the system are made, this may reduce the moisture resistance of the building and allow ingress of water.
E	Resistance to the passage of sound	Where holes for pipes or cables are made, this may reduce the soundproof integrity of the building structure.
G	Sanitation, hot-water safety and water efficiency	Where all connections are made to drainage systems.
H	Drainage and waste disposal	Where gutters and rainwater pipes are connected to the system.
P	Electrical safety	The installation of electrical controls and components must be considered.

Other regulatory requirements to consider

The Water Supply (Water Fittings) Regulations 1999 apply to greywater recycling installations. The key area of concern will be the avoidance of cross-contamination between greywater and wholesome water. This is known as 'backflow prevention' and, as greywater is classified as a category 5 risk, the usual method of providing backflow prevention is with an air gap between the wholesome water and the greywater.

Any pipework used to supply outlets with the treated greywater will need to be labelled to distinguish it from pipework for wholesome water. Outlets will need to be clearly identified by means such as labelling. Outlets will also need to be labelled to indicate that the water supplied is not suitable for drinking.

There are other regulatory requirements to consider regarding the installation of greywater reuse systems.

- The local water authority must be notified when a greywater reuse system is to be installed.
- **BS 7671: 2018 (2022)** The IET Wiring Regulations, 18th Edition, including amendments, will apply to the installation of supplies and control systems for the greywater reuse system.

The advantages and disadvantages of greywater reuse systems

The advantages of greywater reuse systems are that:

- the cost of water bills will reduce if the supply is metered
- they reduce demands on the wholesome water supply
- a wide range of system options exists
- they have the potential to provide more reusable water than rainwater-harvesting systems.

The disadvantages of greywater reuse systems are that:

- there are long payback periods
- they can be difficult to integrate into an existing system
- only certain types of appliance or outlet can be connected; this causes additional plumbing work
- cross-contamination can be a problem
- a water meter will need to be fitted to achieve maximum financial gains
- the need for filtering and pumping may increase rather than decrease the carbon footprint.

Test your knowledge

- 1 Which Part of the Building Regulations sets the requirements for resistance to the passage of sound?
 - a B
 - b C
 - c D
 - d E
- 2 What is the heat source used in a solar thermal hot-water system?
 - a Biofuels.
 - b Radiation from the Sun.
 - c Natural gas.
 - d Ground-source energy.
- 3 Which environmental technology uses slinkies in its system?
 - a Photovoltaic (PV) systems.
 - b Biofuel heat systems.
 - c Rainwater harvesting.
 - d Ground-source heat pumps.
- 4 Which of the following is a common source of biomass fuel?
 - a Food waste.
 - b Coal pellets.
 - c Purified gas.
 - d Waste rubber.
- 5 What term relates to a micro-wind system that supplies batteries which are independent from electrical supply systems?
 - a On-grid.
 - b Open source.
 - c Off-grid.
 - d Closed source.
- 6 What is the device that converts DC to AC in a photovoltaic system?
 - a Rectifier.
 - b Converter.
 - c Inverter.
 - d Corectifier.
- 7 What specifically affects the efficient output of a photovoltaic array?
 - a Direction and tilt.
 - b Height and tilt.
 - c Height and temperature.
 - d Direction and temperature.

- 8 Which technology creates shadow flicker?
 - a Micro-hydro.
 - b Wind turbine.
 - c Biomass fuel.
 - d Air-source heat.
- 9 What is the name given to the pipework supplying water to a hydro-electric turbine?
 - a Tail race.
 - b Forebay.
 - c Penstock.
 - d Canal.
- 10 What does the abbreviation CHP stand for in environmental technologies?
 - a Coiled heat pump.
 - b Constant heated position.
 - c Cooled hydro power.
 - d Combined heat and power.
- 11 State three suitable uses for harvested rainwater.
- 12 Describe what needs to be considered when positioning a photovoltaic system.
- 13 List the component parts in a solar thermal hot-water system.
- 14 Explain how Part A of the Building Regulations affects the installation of a photovoltaic array.
- 15 Explain what is meant by the term 'permitted development'.
- 16 What form of environmental technology uses an evacuated-tube collector?
 - a Photovoltaic generators.
 - b Solar thermal hot water.
 - c Biomass heat boilers.
 - d Micro-wind turbines.
- 17 What technology requires servicing under F Gas Regulations?
 - a Photovoltaic generators.
 - b Biomass boiler systems.
 - c Ground-source heat pumps.
 - d Hydro generation systems.
- 18 What does the term 'wholesome water' refer to?
 - a Drinking water.
 - b Toilet waste.
 - c Dishwasher waste.
 - d Rainwater.

- 19 What Approved Document details the requirements for electric vehicle charging systems in dwellings?
- a A
 - b L
 - c R
 - d S
- 20 Which heating technology produces more heat output in watts compared to the energy consumed?
- a Air-source heat pump.
 - b Electric panel heaters.
 - c Gas-fired boiler system.
 - d Oil-fired boiler system.
- 21 Which of these is used to store excess heat produced by a heat pump?
- a Storage battery.
 - b Buffer tank.
 - c Slinkies.
 - d PV cell.
- 22 Which part of the refrigeration cycle causes the refrigerant gas to significantly increase in heat?
- a Exchanger.
 - b Expander.
 - c Condenser.
 - d Compressor.
- 23 What is the **optimum** tilt angle for a solar array in the UK?
- a 0° to 20°
 - b 20° to 30°
 - c 30° to 40°
 - d 50° to 60°
- 24 Explain why a PV system may require planning consent.
- 25 Explain why situating a wind turbine on a cliff is unsuitable.
- 26 Explain the advantage of using a micro-CHP boiler.
- 27 Give **two** disadvantages of an air-source heat pump.

ADVANCED SCIENTIFIC PRINCIPLES

INTRODUCTION

Scientific principles underpin all technical subjects in electrical installation work. Without a basic understanding of the science, it is not possible to understand how systems and equipment function and protect. A skilled electrician needs to understand the dangers electricity can create in all situations. They are only able to do that by knowing the science and principles behind electricity, electrical systems, materials, equipment and components.

T Level mapping grids are available on the Hodder Education website. These map the book to the occupational specialisms: 8710-353 (Electrical Engineering) and 8710-352 (Electrical and Electronic Equipment).

HOW THIS CHAPTER IS ORGANISED

This chapter covers the advanced science needed to understand AC systems. It also focuses on specific components and the operating principles of equipment that is commonly designed and installed. This equipment includes lighting systems, heating systems, protective devices, transformers and motors.

Table 2.1 shows how the contents of this chapter map to the qualification you are studying. For those who are studying 8710 T levels, most of this science is covered in the core unit, but the principles in this chapter will also reinforce learning throughout the electrical-related specialisms.

▼ Table 2.1 Chapter 2 assessment criteria coverage

Topic	5357	2365-03	8202-03	5393-103
Electrical supply and distribution systems	7.1; 7.2; 7.3; 7.4; 7.5; 7.6; 7.7 8.8	1.1; 1.2; 1.3; 1.4; 1.5; 1.6; 1.7 2.8	1.1; 1.2; 1.3; 1.4; 1.5 2.4	6.1; 6.2; 6.3; 6.4; 6.5; 6.6
Electrical circuits, systems and equipment	8.1; 8.2; 8.3; 8.4; 8.5; 8.6; 8.7; 8.8	2.1; 2.2; 2.3; 2.4; 2.5; 2.6; 2.7; 2.8	2.1; 2.2; 2.3; 2.4	7.1; 7.2; 7.3; 7.4
Operating principles and applications of DC machines and AC motors	9.1; 9.2; 9.3; 9.4	3.1; 3.2; 3.3; 3.4	3.1; 3.2; 3.3	8.1
Operating principles of different electrical components	10.1	4.1	3.4	8.1
Electrical lighting systems	11.1; 11.2	5.1; 5.2	4.1; 4.2	9.1; 9.2; 9.3
Principles and applications of electrical heating	12.1; 12.2	6.1; 6.2	5.1; 5.2	10.1; 10.2; 10.3

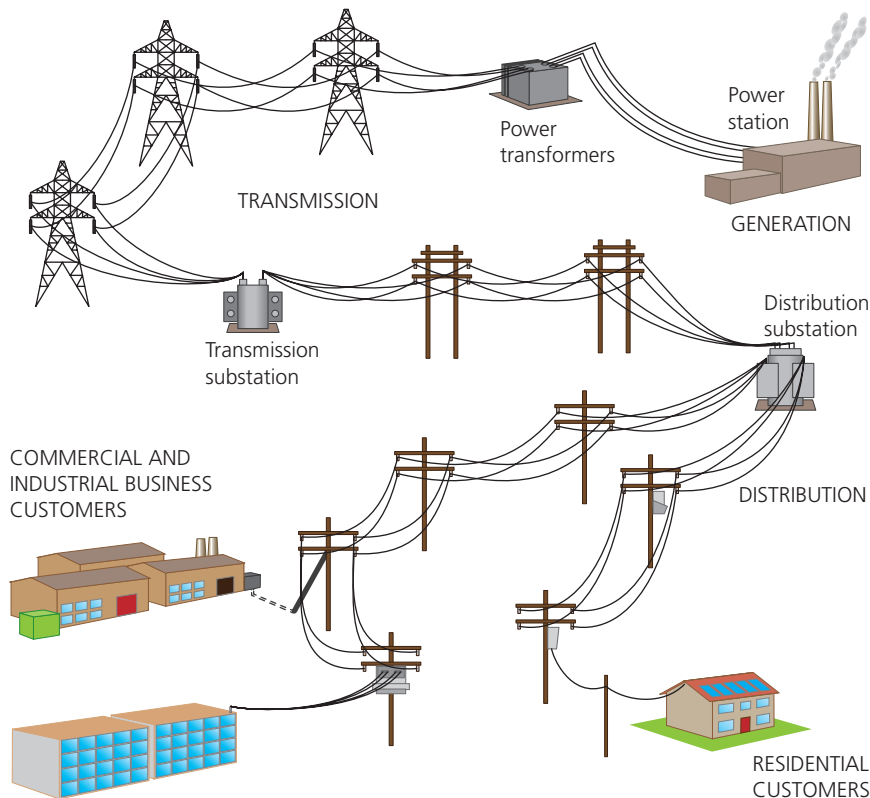

▲ Figure 2.1 Electricity generation, transmission, distribution and use

POWER GENERATION AND SUPPLY

The privatised power system

Upon privatisation in 1990, the 12 regional English electricity boards were turned into 12 separate companies, with the intention of them buying their electricity wholesale, at market rates, and mainly from the three concerns that produced the electricity: National Power and Powergen, which took over the CEBG's big coal-fired power stations in 1991, and British Energy, owner of the newest nuclear stations. The transportation of electricity between power stations and from region to region, was carried out by National Grid, owned jointly at first by the 12 local electricity firms and then, after 1996, as an independent commercial enterprise.

However, in addition to the large generating stations connected to the transmission system, an increasing number of small electricity generating plants are connected throughout the distribution networks rather than the transmission system. Generation connected to the distribution network, which is owned by the distribution network operators (DNOs), is called distributed generation (DG). This results in power flowing from both the distribution network to customers and from customers with DG into the distribution network.

INDUSTRY TIP

In the early days, local areas were supplied by their own generating station and there was no standard supply voltage. It was not until the National Grid was put into place that supply voltages became more standardised.

The different organisations

Generators – generating organisations own, operate and maintain power stations that generate electricity from different energy sources: coal, gas, hydro and nuclear. As new technologies emerge, the mix of generation is being augmented with wind, solar, wave, pumped storage and tidal power.

Transmission system owner – there are a number of transmission licence holders in Great Britain. The main three that maintain the majority of the grid are National Grid, Scottish Power and SSE. They own and maintain most of the high-voltage transmission system in the UK. There are also a number of other organisations who maintain sections of the grid which link to new electricity generation systems such as off-shore wind turbine farms.

System operator – because it is difficult to store large quantities of electricity, the demand has to be balanced with the generation output, and the system operator can ask generators to increase output or large customers could be asked to reduce their demand (subject to contract conditions).

Distribution network operator (DNO) – a DNO owns, operates and maintains a public distribution network. There are presently seven DNOs in Great Britain and they often form part of a group that undertakes other areas of business, such as electricity supply.

Independent distribution network operator (IDNO) – an IDNO designs, builds, owns, operates and maintains a distribution network which is normally an extension of an existing DNO network. IDNOs build networks for new developments, such as business parks, retail and residential areas.

Suppliers – supply is the retail arm for the provision of electricity. Suppliers buy in bulk and then sell to customers. They are responsible for providing bills and customer services and arranging metering.

ACTIVITY

There are several major retailers of electricity. You do not have to live in a particular area to access their services. A customer in Cornwall could buy their electricity from a supplier in Scotland. Can you name six major suppliers?

Three-phase AC generators

In the UK, three-phase generators are used in power stations.

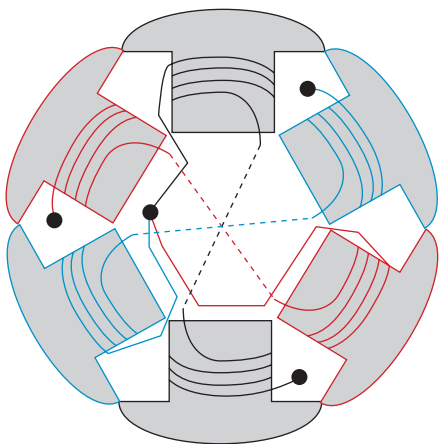

▲ Figure 2.2 Six-pole (three pairs) salient pole rotor (star wound) for an alternator



▲ Figure 2.3 Large-scale AC generation

A three-phase AC generator has a stator with three sets of windings arranged so that there is a phase displacement of 120° . The three-phase output is produced by either star- or delta-connected windings on the stator.

How AC generators work

For simplicity, the description below relates to one phase. However, it is important to remember that there are three phases, displaced at 120° from each other.

As each pair of poles passes through the strongest part of the magnetic field at right angles, the maximum electromotive force (emf) is induced into that particular phase. At that point, the other two pairs are in a weaker part of the field and a lower voltage is induced. The moving rotor is connected to the stationary external connections by brushes and slip rings, which keep each phase in constant contact.

The output of an AC system, when measured and tracked, is usually referred to as a waveform. This is because, as the rotating machine induces an emf, the value rises to a peak, falls to zero, then to a negative peak value and then rises back to zero.

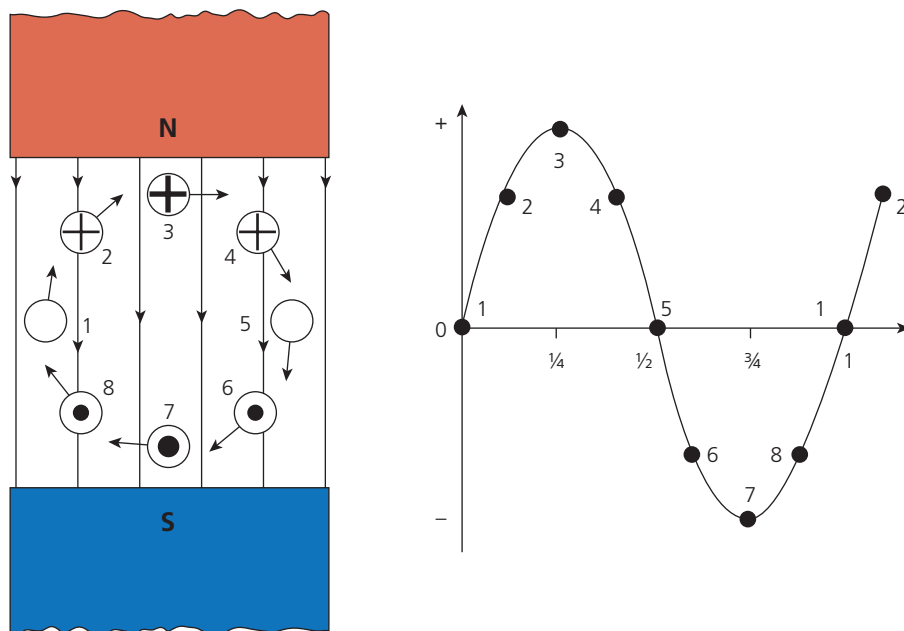

▲ Figure 2.4 The emf generated per phase per rotation

The time taken for the cycle to return to its starting position (from position 1 back to 1 in Figure 2.4) is the periodic time t . This process can be described in terms of Faraday's law because the rotation of the coil continually changes the magnetic flux through the coil and therefore generates an emf.

In the UK, large amounts of electricity are generated at high voltage in power stations. This electricity is typically between 23 and 25 kV and is transformed

IMPROVE YOUR MATHS



Remember, $E = \beta lv$

INDUSTRY TIP

Rotor bars are also formed by casting aluminium into the rotor.

KEY TERMS

Step-up transformer: A transformer that has a proportionally higher number of turns on the secondary (output stage) than on the primary (input stage).

Step-down transformer: A transformer that has a proportionally higher number of turns on the primary than on the secondary.

to EHV (extra high voltage) 275 kV or 400 kV systems through **step-up transformers**. Once the electricity is transmitted to its region, it is transformed down to a more manageable voltage through **step-down transformers**. These distribution systems then deliver electricity at the correct voltage for the load, usually ending with an 11 000 V or 400 V transformer to supply both three- and single-phase installations at a local level of 230 V or 400 V.

A network of circuits, overhead lines, underground cables and substations link the power stations and allow large amounts of electricity to be transmitted around the country to meet the demand. Alongside the seven local distribution networks operating at 132 kV, 66 kV, 33 kV and 11 kV, there are also four high-voltage transmission networks operating at 400 kV (super grid) and 275 kV (the grid) in the UK. The 400 kV network was installed in the 1960s to strengthen the 275 kV system which began operating in 1953. The 400 kV network has three times the power-carrying capacity of one 275 kV line and eighteen times the capacity of a 132 kV line.

Primary distribution by the DNOs is usually carried out at 132 kV, using double circuit steel tower lines feeding primary substations, which in turn feed supplies at either 66 kV or 33kV. The purpose of these primary substations is to supply larger industrial installations and the secondary distribution networks in urban and rural areas. Secondary distribution networks carry supplies from the primary substations via overhead lines on wooden poles or underground cables. Customers are connected at low voltage 230–400 V single or three phase.

Interconnected capacity

Interconnectors between Europe and the UK provide a pooling of capacity and diversity of supplies between the UK and Europe. This is provided by High Voltage Direct Current, which is a way of conveying electricity over very long distances with fewer transmission losses than an equivalent HVAC solution. It also provides greater control over the transmission of electricity, including ability to change size and direction of power flow. Direct current supplies are usually obtained from AC mains supplies, first by using a transformer to change to the required voltage and secondly by using a rectifier to convert the AC supply to DC. Unfortunately, the rectification process is not perfect and some superimposed ripple is likely to appear on the DC output.

The current interconnectors in operation are:

- 2 GW between England and France
- 1 GW between England and the Netherlands
- 500 MW between England and Northern Ireland.

Other methods of generation

The majority of electricity generation is produced by the conversion of heat or thermal energy (steam) to some form of mechanical energy (i.e. by turning a turbine) which in turn forces a generator to turn.

INDUSTRY TIP

A small number of power stations burn household refuse, which to a certain extent solves the landfill problem.

Standby supplies have diesel generators for use when the public supplies are not available.

The burning of fossil fuels (coal, gas, petroleum/diesel) and nuclear fission have been the main sources of the heat to produce the steam to drive turbines.

Steam to drive turbines can also be produced by the following:

- **biomass** – such as wood, palm oil and willow
- **solar thermal** – Sun's heat energy is transferred to fluids
- **geothermal** – either directly from steam in the ground or via heat transfer.

Other means of turning a turbine are described below.

- **Water** – hydroelectric, pumped storage or micro-hydro systems where the water turns turbine blades. Unlike large-scale hydroelectric schemes, such as Three Gorges Dam in China, micro-hydro systems use small rivers or streams to produce up to 100 kW of power.
- **Wind** – the turbines used in a wind farm for commercial electricity generation are usually three bladed and can have a wing tip speed of 200 mph.

ACTIVITY

Why are hydroelectric systems normally confined to Scotland and Wales?

ACTIVITY

Dinorwig is an example of a pumped storage electricity scheme. Find out how and when Dinorwig produces electricity.



▲ Figure 2.5 Dinorwig (North Wales) pumped storage electricity generation scheme



▲ Figure 2.6 A typical offshore wind farm installation

A growing proportion of the UK's electricity is already generated from renewable sources but, with concerns about the depletion of fossil fuels, this is expected to grow significantly over time. Electricity generation from wind power increased by 715% between 2009 and 2020 according to the Office for National Statistics (ONS).

Other ways that electricity can be generated are:

- **solar photovoltaic cells (PV)** – these convert sunlight into electricity and although the PV concept is associated with small PV panels on domestic and commercial premises, many large PV power stations have been installed with hundreds of MW being produced
- **combined heat and power (CHP)** including micro CHP – in conventional power stations the waste heat is normally discarded via large cooling towers, whereas in a CHP generation system the waste heat or thermal energy is captured and used for heating schemes or production processes
- **batteries and cells** – when two different metals are placed in an **electrolyte**, ions are drawn towards one metal and electrons to the other. This is called a cell and produces electricity. Many cells joined together are called batteries.

KEY TERM

Electrolyte: A chemical solution that contains many ions. Examples include salty water and lemon juice. In major battery production, these may be alkaline or acid solutions, or gels.

Source and arrangements of supply

As was discussed earlier, a number of different electricity supply systems may be used in work premises, catering for specific requirements. These may be DC or AC operating at different voltages, and in the case of AC the supply may be single- or three-phase.

Direct current is not used for public electricity supplies (with the exception of the links between England, the Netherlands, Ireland and France) but has some work applications, e.g. battery-operated works plant (fork lift trucks, etc.). Certain parts of the UK railway system, in particular the London Underground and services in Southern England, also use DC for traction supplies.

DC battery systems are becoming more common as storage solutions for installations. These are of particular use where added demand, such as those of electric vehicle charging points, are added to installations. The introduction of Approved Document S means that many new houses will require a vehicle charging point to be installed. If these are used regularly, the added burden on the supply could be damaging so storage systems may be needed to help with demand.

Alternating current is the distribution system of choice for electricity suppliers all over the world. The main reason is its versatility. Using an AC supply permits wider scope concerning circuit arrangements and supply voltages, through the use of transformers, which enables the supply voltage to be changed up or down.

These different types of AC supply systems will now be explained.

Single-phase and neutral AC supplies

As with DC, the simplest AC supply arrangement is a two-wire system, known as a single-phase supply. This is the arrangement provided for domestic premises, as well as for many supplies within work premises (lighting, socket outlets, etc.). The two conductors are referred to as the line conductor (L) and the neutral conductor (N). The neutral conductor is connected to protective earth (PE) at every distribution substation on the public supply system and therefore the voltage of the neutral conductor, with reference to earth, at any point should be no more than a few volts. The voltage between the L and N conductors corresponds to the nominal supply voltage (230 V).

INDUSTRY TIP

In very rare circumstances an installation may be supplied with a two-phase and neutral supply. This is not to supply 400 V equipment but perhaps a large heating load which cannot be accommodated by a single-phase supply only.

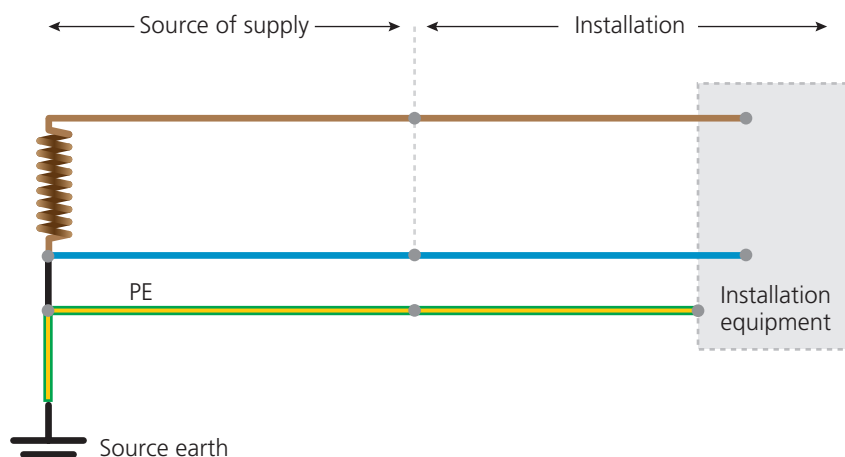

▲ Figure 2.7 Single-phase AC supply

Balancing a single-phase load across a three-line supply

In the UK, electricity is provided from a delta star transformer (commonly referred to as a DYN11) with an earthed star point on the secondary side of the transformer. This is normally distributed as a three-phase four-wire system, as indicated in Figure 2.8.

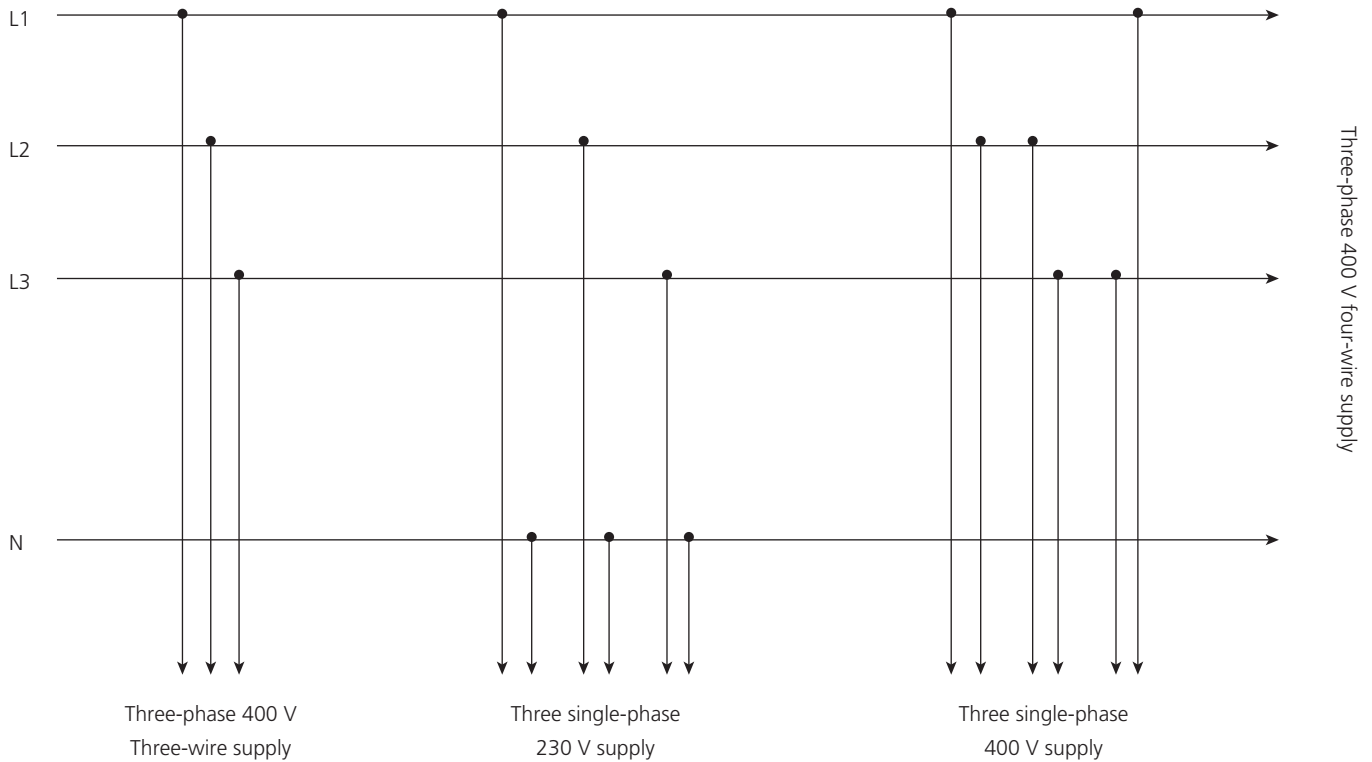

▲ Figure 2.8 Three-phase four-wire distribution system

INDUSTRY TIP

Consider nine houses, exactly the same, connected to a three-phase supply. In theory the loads should be balanced, but each household will get up at slightly different times, switch on different numbers of lamps, TVs and heaters, etc. The loadings will be close but not exactly the same.

Balanced three-phase systems, as described above, will balance out, therefore giving no neutral current.

Single-phase loads require a neutral connection. With single-phase loads, the neutral will carry any out-of-balance current. This should be kept to a minimum, to reduce cable and switchgear sizes and to ensure maximum transformer use. Any difference in load will be 'mopped up' by current flowing in the neutral conductor.

It must be mentioned at this point that the effects of neutral current become much more complex with different loads. This subject is for later on in your studies.

Values of neutral current can be determined simply by using a scale drawing based on an equilateral triangle. If all phases are balanced, therefore equal, all three sides of the triangle will meet. If they are not balanced, there will be a gap, which represents the neutral current.

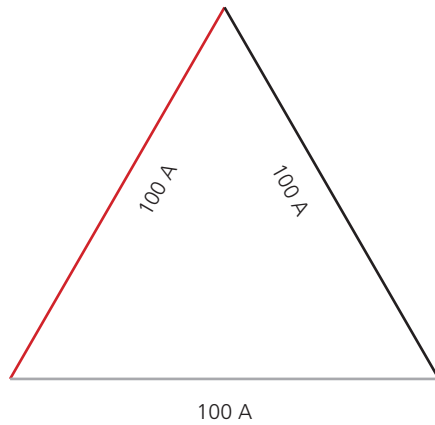

▲ Figure 2.9 This triangle represents a balanced system

If an unbalanced system had the following values:

- L1 – 70 A
- L2 – 100 A
- L3 – 60 A

the neutral current would be as shown in Figure 2.10.

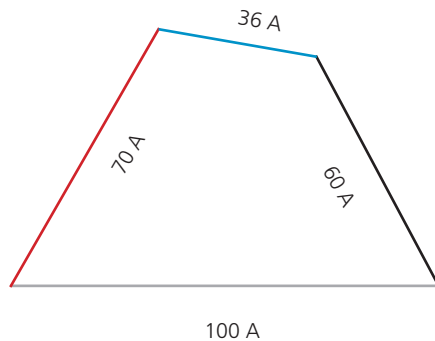

▲ Figure 2.10 This diagram represents an unbalanced system

Represent the largest current by the base of the triangle. Draw the other two sides, each at 60° to the base, and mark off lengths to represent the other two currents, to scale. Join the top points of these two sides. This line represents the 'gap' and can be measured and converted, using the same scale. In Figure 2.10, the gap, indicating the neutral current, represents approximately 36 A.

Three-phase and neutral AC supplies (star connected)

Whilst single-phase AC supplies are adequate for domestic premises, the much higher loads typical of industrial and commercial premises would result in the need to use very large conductors to carry the high currents involved. The high currents would also give rise to a large volt drop.

However, it is possible to use a **multi-phase** arrangement, which effectively combines several single-phase supplies. If three coils spaced

IMPROVE YOUR MATHS



An equilateral triangle is formed by angles of 60° .

ACTIVITY

The load will always be unbalanced unless naturally balanced equipment is used. Identify some electrical equipment that will maintain a balanced load.

IMPROVE YOUR MATHS



When constructing scaled diagrams, it is crucial to use an appropriate scale and to measure accurately.

KEY TERM

Multi-phase: More than one phase. **BS 7671** sometimes uses the term Polyphase to mean more than one phase.

ACTIVITY

Why is the star point of the transformer connected to earth?

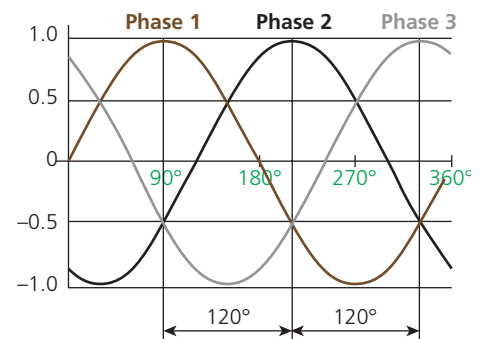

▲ Figure 2.11 Three-phase sine wave where each waveform is 120° apart

INDUSTRY TIP

If you look at the three-phase waveform in Figure 2.11 you will see that all three currents are constantly changing. At 90°, L_1 shown in brown is 100% positive and L_2 shown in black and L_3 shown in grey are 50% each negative. As you move along you will see that the positive values always equal the negative value.

120° apart are rotated in a uniform magnetic field, we have an elementary system which will provide a symmetrical three-phase supply.

The usual arrangement is a three-phase system with four conductors – three separate line conductors and a common neutral conductor, as shown in Figure 2.12. Most substation transformers in the distribution system that delivers power to houses are wound in a delta-to-star configuration. A neutral point is created on the star side of the transformer.

The three line conductors (L_1 , L_2 and L_3) were previously distinguished by standard colour markings: red, yellow and blue. However, European harmonisation has now resulted in these conductor colours being changed to brown, black and grey.

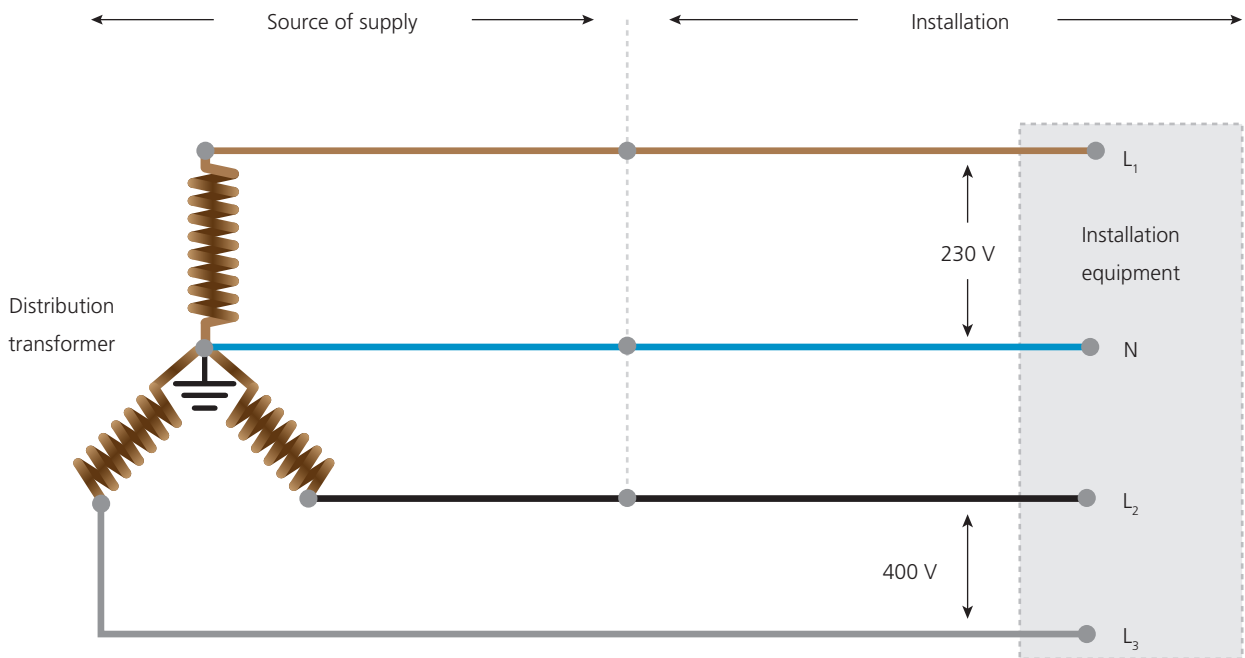

▲ Figure 2.12 Three-phase AC supply

Voltage and current in star-configured systems

In a star (Y) connected load:

- the line current (I_L) flows through the cable supplying each load
- the phase current (I_p) is the current flowing through each load.

So:

$$I_L = I_p$$

and:

- the voltage between any line conductors is the line voltage (V_L)
- the voltage across any one load is the phase voltage (V_p)

ACTIVITY

For a star-connected system, calculate the phase voltage when the line voltage is: a) 400 V, b) 415 V, c) 11 kV, d) 110 V.

so:

$$V_P = \frac{V_L}{\sqrt{3}} \text{ or } V_L = V_P \times \sqrt{3}$$

In a balanced three-phase system there is no need to have a star-point connection to neutral as the current drawn by any one phase is taken out equally by the other two. Therefore the star point is naturally at zero.

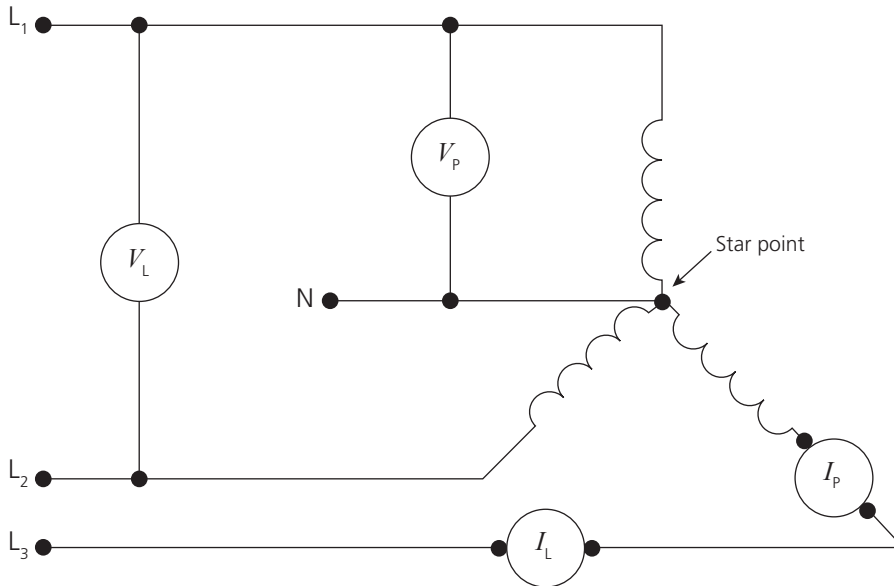

▲ Figure 2.13 Star-connected load

So if a line current is 10 A, the phase current will also be 10 A. If the line voltage was 400 V, the phase voltage would be:

$$\frac{400}{\sqrt{3}} = 230 \text{ V}$$

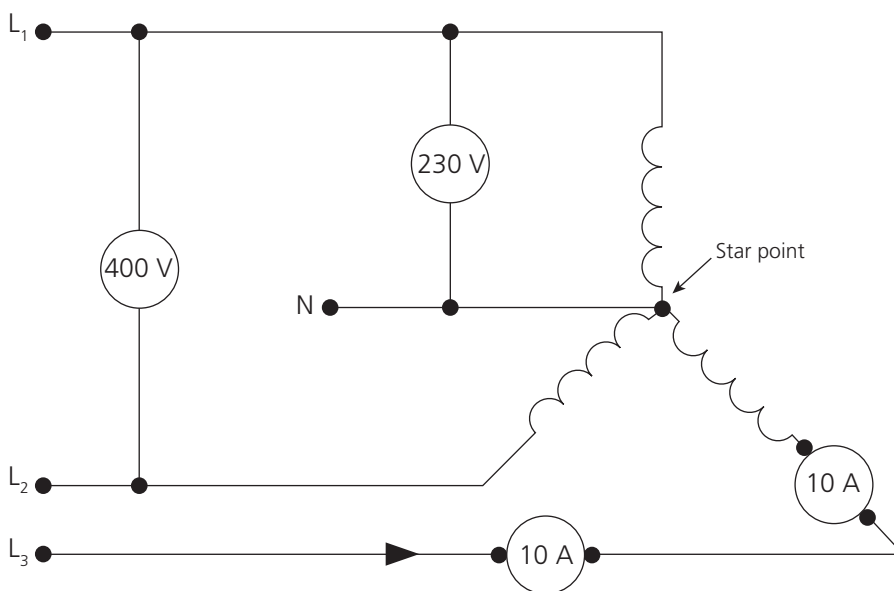

▲ Figure 2.14 Common phase and line currents in load

Neutral current in three-phase and neutral supplies

In a balanced three-phase system there is no requirement to have a star-point connection as the three phases have a cancellation effect on each other. Therefore the star point is naturally at zero current. While the load is balanced and the waveforms are symmetrical (not containing harmonics or other waveform distorting influences), this statement is relatively accurate. However, in practice, this is sometimes not the case.

Where the load is not in balance, different currents circulate in the load through the source winding and back. This gives rise to a change in star-point voltage, which can result in the system 'floating' away from its earthed reference point. In essence, a current will flow in the neutral. The three ways in which this current value could be determined are:

- by phasor, an accurate method that indicates the angle at which the maximum current occurs
- by calculation, which gives an accurate value
- by equilateral triangle, which gives a good indication of the value.

Three-phase AC supply (delta connected)

In a delta-connected system, each of the three coil windings is wound in such a way that each winding has a start and finish and the start of each winding is connected to the finish of the other winding. This gives a triangle or delta configuration. The supply is then taken from the interconnection of each winding, which means that a three-phase system can be obtained using only three wires.

Voltage and current in delta-configured systems

INDUSTRY TIP

This was once referred to as a mesh connection. A delta connection will provide three times more power than a star connection using the same resistors or motor coils, etc.

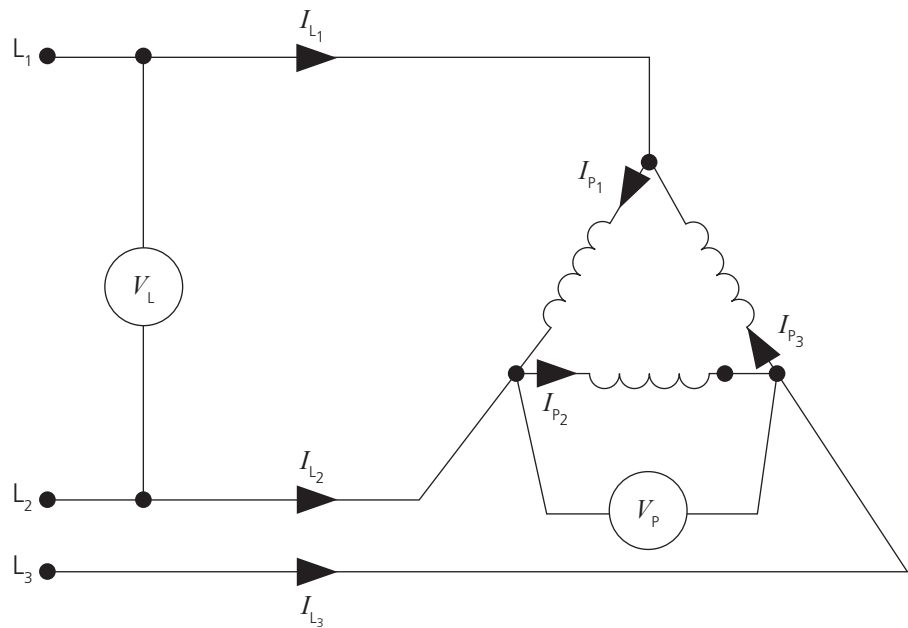

▲ Figure 2.15 Delta-connected load similar to delta-connected supply

In a delta (Δ) connected load:

- the line current (I_L) flows through the cable supplying each load
- the phase current (I_p) is the current flowing through each load.

So:

$$I_p = \frac{I_L}{\sqrt{3}} \text{ or } I_L = I_p \times \sqrt{3}$$

and:

- the voltage between any line conductors is the line voltage (V_L)
- the voltage across any one load is the phase voltage (V_p)

so:

$$V_L = V_p$$

As there is no provision for a neutral connection, items such as delta motors would automatically be balanced – but complex loads on transmission systems could be unbalanced.

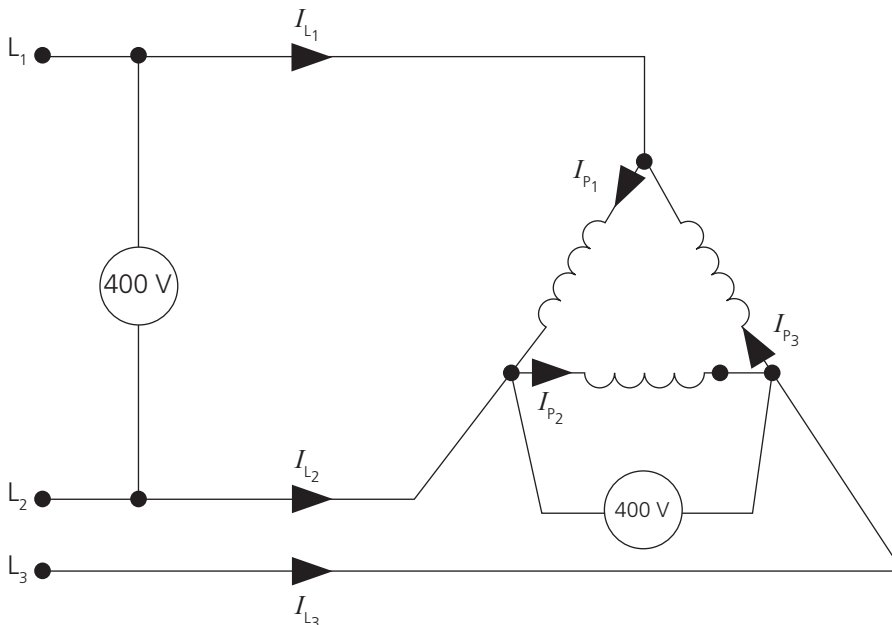

▲ Figure 2.16 Phase and line currents in the load

Therefore if the phase current is 100 A and the phase voltage is 400 V, the line current can be calculated as follows:

$$I_{line} = 1.732 \times 100 = 173.2 \text{ A}$$

Earth fault loop impedance

Earth fault loop impedance is required to verify that there is an earth connection and that the value of the earth fault loop impedance is less than or equal to the value determined by the designer and which was used in the design calculations.

KEY TERM

Earth fault loop impedance:

The impedance of the earth fault current loop starting and ending at the point of earth fault. This impedance is denoted by the symbol Z_s .

ACTIVITY

Using an earth loop impedance tester to measure the earth electrode resistance involves disconnecting which conductor?

The earth fault current loop comprises the following elements, starting at the point of fault on the line to earth loop:

- the protective conductor
- the main earthing terminal and earthing conductor
- for TN systems (TN-S and TN-C-S), the metallic return path or, in the case of TT systems, the earth return path
- the path through the earthed neutral point of the transformer
- the source phase winding
- the line conductor from the source to the point of fault.

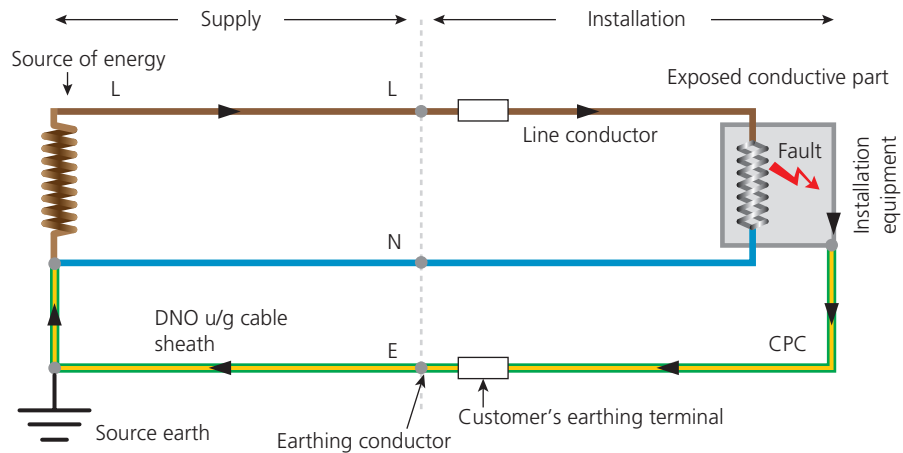

◀ Earth fault loop path

▲ Figure 2.17 Earth fault loop

The earthing system adopted will determine the earth fault loop impedance, and this will determine the method of protection against electric shock.

- TN-C-S systems tend to have low earth fault loop impedances external to the installation. The typical maximum declared value is $0.35\ \Omega$.
- TN-S systems tend to have higher earth fault loop impedances compared to TN-C-S systems. The typical maximum declared value is $0.8\ \Omega$.
- When TT systems are adopted, the resistance of the installation earth will be higher than for TN systems and can be tens or hundreds of ohms. This means that residual current devices (RCDs) will need to be adopted for protection against electric shock as they operate at much lower earth fault currents than standard protective devices.

TRANSFORMERS

The operating principle of transformers

The use of alternating current, rather than direct current, gives more scope for circuit and supply voltages as they can be changed up or down by the use of a transformer.

Transformers are fundamental to the safe and efficient use of electricity. They range from step-down transformers, which provide an extra-low voltage supply

for small electrical appliances, to large step-up transformers that produce voltages of up to 400 kV for power transmission purposes. The wide range of sizes and capabilities corresponds to the everyday requirements of electricity usage.

Although there are many different types and sizes of transformer, they all operate on the same principle. The basic principle is that in two independent coils (windings), a change in the magnetic flux of one coil can induce a magnetic change in the second coil. This is known as static inductance. It is further enhanced when the two electrically separated coils are wound onto a common magnetic core, which creates a common magnetic circuit.

If an AC supply is applied to one coil (known as the primary), the magnetic flux produced by the first coil rotates and cuts through the second coil (known as the secondary), producing an emf in the secondary. This configuration works with AC or chopped DC. The field in the first coil rises and falls rapidly, causing inductance in the adjacent coil.

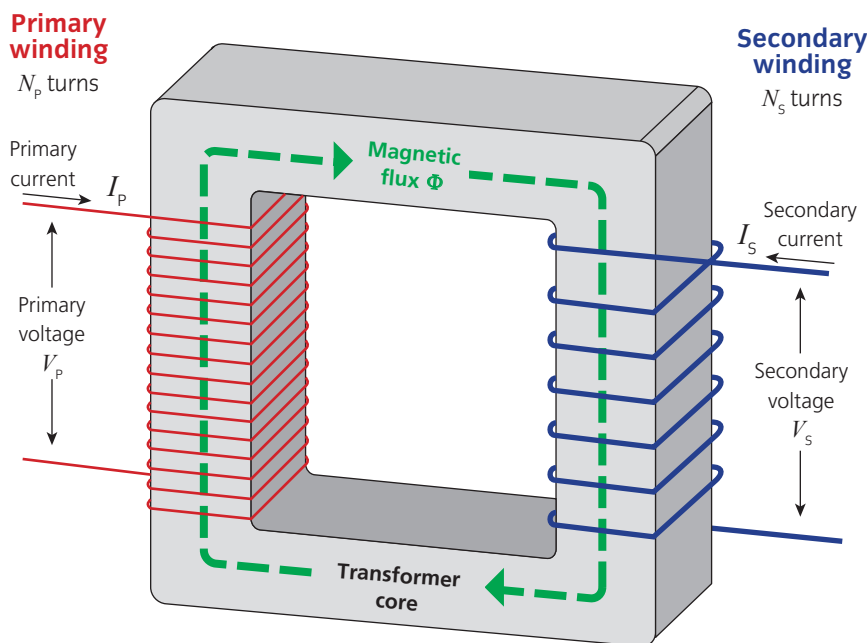

▲ Figure 2.18 Simple transformer arrangement

The ease with which voltages can be changed up or down, coupled with the fact that it is more economical to transmit electricity over long distances at high voltage, is an important reason why AC has been adopted for mains electricity supplies.

Transformers are very efficient devices, particularly when working on full load and, since there are no moving parts, require little maintenance.

Different types of transformers

There is a wide range of electrical transformers, all designed for different uses and purposes. The designs may differ but the fundamental principles are the same.

ACTIVITY

Most transformers are double-wound with separate primary and secondary windings. There is a type of transformer in which a winding is shared between primary and secondary. Find out the name of this type of transformer and investigate how it works.

INDUSTRY TIP

Isolating transformers with two windings work on the principle known as mutual induction. Where transformers have a single winding, they operate using self-induction.

Power transformers

Power transformers are the most common type of transformer and are used as:

- step-up transformers in the transmission of electrical energy from power stations (25 kV–400 kV) and step down from 400 kV to 132 kV
- step-down transformers in distribution substations from 132 kV to 11 kV, and 11 kV to 400 V for use in commercial and domestic situations
- step-down transformers to convert mains voltage of 230 V to extra low voltage to power electronic equipment
- one-to-one transformers where the input voltage is the same as the output voltage, such as a 230 V shaver point used in a bathroom which provides electric shock protection by electrical separation.

The construction of insulated laminations minimises the eddy current produced during the transformation process.

For large power transformers used at generating and distribution substations, oil is used as a coolant and insulating medium. For small rating transformers, the oil is circulated through ducts in the coil assembly and through cooling fins fixed to the body of the transformer tank or, in higher ratings, through separate air-cooled radiators that may use pumps and fans to aid the cooling process.

Cast resin power transformers, where the windings are encased in epoxy resin, are often used where there is a fire risk in indoor situations.

Current transformers

Current transformers have many uses. Those that involve metering require extremely accurate current transformers, such as Class X CTs.

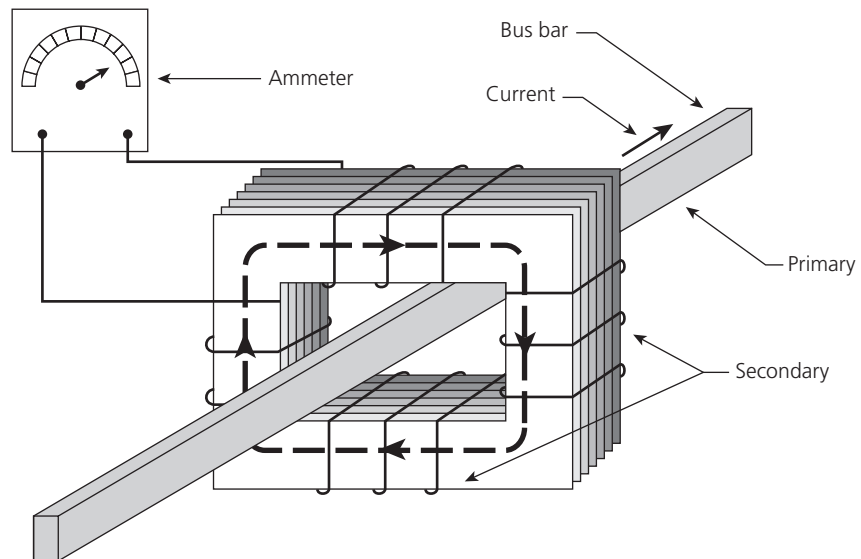

▲ Figure 2.19 A current transformer with secondary winding around the primary conductor

A current transformer has a primary winding, a magnetic core and a secondary winding. The magnetic core and secondary winding surround the primary winding, which is a simple conductor giving one single turn.

ACTIVITY

A typical current transformer (CT) would have a ratio of 800:5, so for every 800 A on the primary there would be 5 A on the secondary, allowing a 5 A meter to be used if the maximum current on the primary was 800 A. What size meter would be needed if the CT had a ratio of 1360:5 and the maximum current on the primary was still 800 A?

The AC flowing in the primary conductor produces a magnetic field in the core, which then induces a current in the secondary winding circuit.

It is extremely important when positioning the current transformer to ensure that the primary and secondary circuits are efficiently coupled to give an accurate reading. It is also very important to ensure that the current transformer is always connected on the secondary side, either by a measuring instrument or a shorting link. If the current transformer is left open circuit, a large voltage discharge will occur.

Isolation transformers

Isolation transformers are available for step-up, step-down or straightforward 1:1 isolation purposes. Their uses are quite diverse but ultimately they are intended to ensure electrical separation from the primary supply, usually for safety purposes.

These transformers have additional insulation and electrostatic shielding. In some cases, one or both sides of the transformer remains separated from earth by a resistance or they have no connection at all.

A common use for isolation transformers is the domestic shaver socket arrangement, which is isolated from earth to minimise any shock hazards from touching live parts. Because the parts are isolated and the current cannot flow back to its origin (the secondary side of the transformer) via the earth path, the shaver socket cannot deliver a shock under first-fault conditions. Isolation transformers are also used in many medical situations in order to prevent first-fault failures. These systems are also known as medical isolated power supplies (IPS).

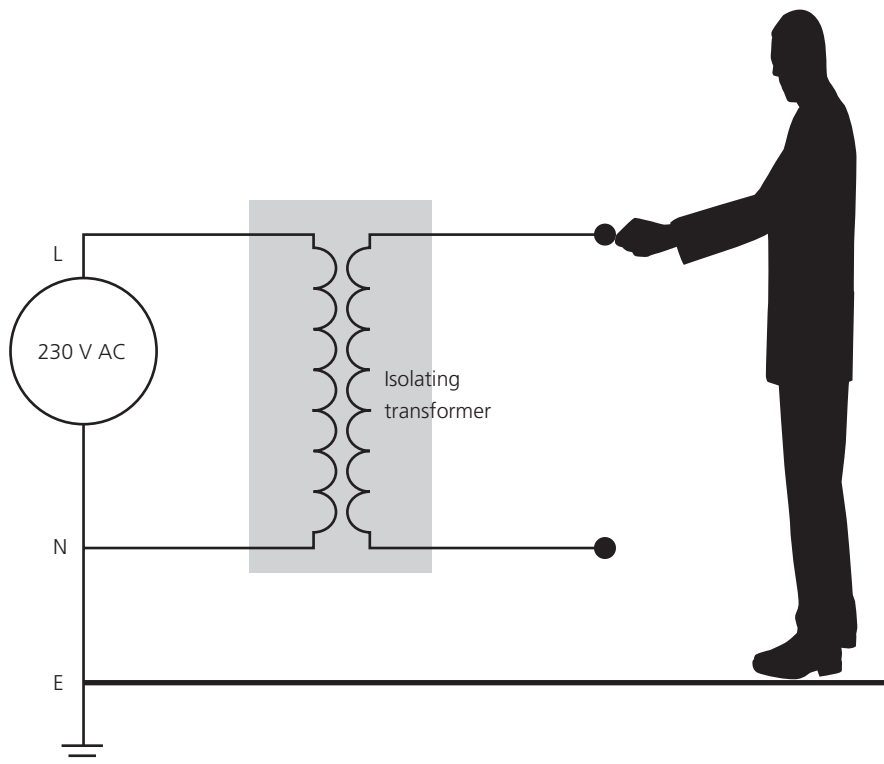

HEALTH AND SAFETY

Remember, you will still get a shock between the two transformer output terminals.

▲ Figure 2.20 An isolated supply, such as in a BS EN 61558-2-5 shaver socket outlet, minimises the risk of shock

INDUSTRY TIP

The lower voltage winding is normally wound closest to the core for safety reasons. Some windings are placed on top of each other; other types use a sandwich arrangement.

Voltage transformers

A voltage or potential transformer has two windings wound around a common core. See Figure 2.18, which shows a simple transformer arrangement.

Earthing transformers

Earthing transformers are used to provide a physical neutral for power transformers with a delta-connected secondary. The earthing transformer neutral point has low impedance and is suitable for different earthing systems, such as solid earthing, NER earthing (resistor) and resonance earthing (Arc Suppression Coil).

Transformer cores

The core of a transformer is generally one of two types: core or shell.

The shell-type transformer is regarded as being more efficient as the magnetic flux is able to circulate through two paths around the core. The core-type transformer only channels flux through one path, meaning that some of the flux is lost at the core corners (leakage flux).

ACTIVITY

There is a third type of core. Find out what it is.

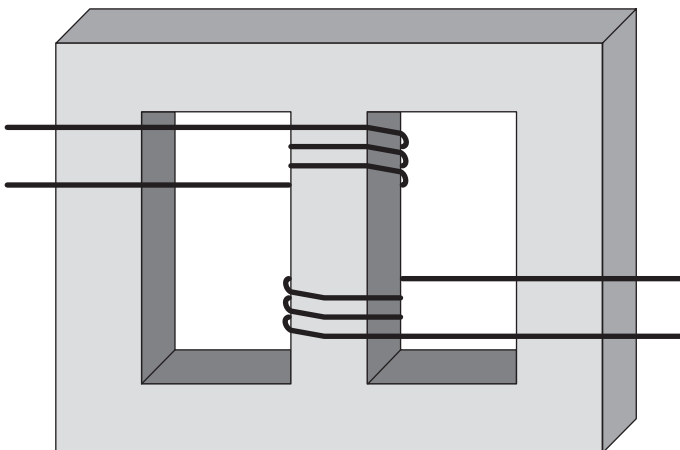

▲ Figure 2.21 Shell-type core

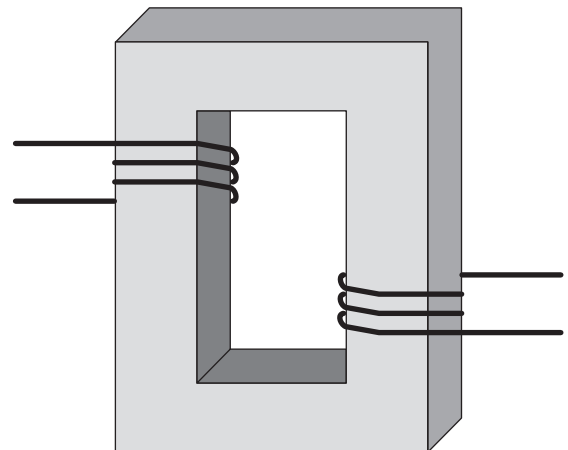

▲ Figure 2.22 Core-type core

Transformer laminations

Transformer cores are made up of laminations. Laminations are thin, electrically insulated slices of metal that, when stacked on top of one another, form a large core. These thin laminations are used to reduce eddy currents in the transformer core.



▲ Figure 2.23 Laminations used to form a transformer core

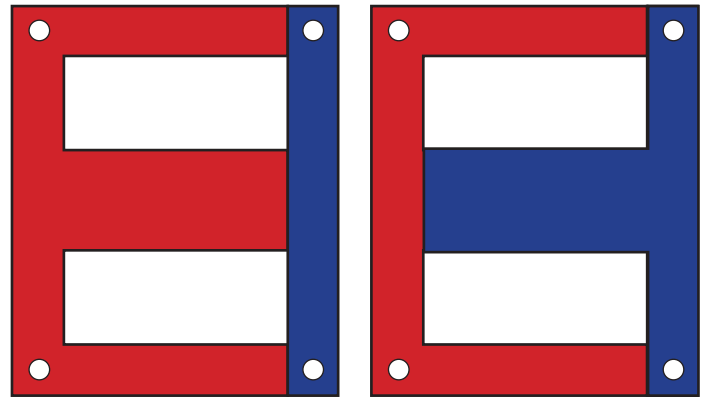

▲ Figure 2.24 Laminations are stacked to form a shell-type core

Eddy currents are products of induction. Small rotating currents, like those swirling currents seen in rivers, rotate around a transformer core. If allowed to, these currents produce heat that ends up as a loss of energy. Making a transformer core with thin, insulated laminations prevents eddy currents from flowing, thus reducing any loss. Eddy current loss is a form of iron loss, that is, losses in the core of a transformer.

Another type of loss is hysteresis loss. This is due to the transformer core being magnetised in one direction, then re-magnetised in the other direction as the supply alternates. If the material requires energy to re-magnetise it, this also becomes a loss. Careful consideration of the material used to construct the core reduces hysteresis loss.

Further losses in transformers are copper losses. This is a loss due to the heating effect of current passing through the windings. The windings are resistances and as in any resistance, the power dissipated, or lost, is usually determined as I^2R .

This is because power is determined by:

$$P = V \times I$$

and voltage is determined by:

$$V = I \times R$$

so power can also be expressed as:

$$P = I \times I \times R \text{ or } I^2R$$

Inductance

There are two types of inductance in relation to transformers: self-inductance and mutual inductance.

Self-inductance is where a transformer winding induces a magnetic field that rotates around the core and induces a current back into the winding,

INDUSTRY TIP

Eddy current and hysteresis are known as iron losses and, given a fixed frequency, are normally considered to be constant. Copper losses occur in the windings and are proportional to the square of the load current.

ACTIVITY

The copper losses in the windings of a transformer are proportional to I^2R . As R is a constant, then the losses are really proportional to I^2 . What other losses occur in a transformer?

IMPROVE YOUR MATHS

When working out transformer ratios, use the winding to winding values – that is, phase voltage to phase voltage ($V_p - V_s$).



limiting current flow. This principle is used in choke/ballast units in fluorescent luminaires.

Mutual inductance is where a primary winding induces a magnetic field that induces a current into a second winding, as in current and voltage transformers.

Relationship of emf produced and number of turns

The proportion of emf produced is related to the number of turns on the primary coil with respect to the secondary coil. This relationship can be determined by:

$$\frac{E_1}{E_2} = \frac{N_1}{N_2}$$

where:

E_1 = emf induced in the primary (V_1)

E_2 = emf induced in the secondary (V_2)

N_1 = number of primary turns

N_2 = number of secondary turns.

As power transformers have very low impedance, there is negligible error in assuming that the voltage on the primary is the same as the emf induced on the primary, and likewise for the voltage and emf on the secondary.

A reasonable assumption is that:

$$\frac{E_1}{E_2} = \frac{V_1}{V_2}$$

Therefore:

$$\frac{V_1}{V_2} = \frac{N_1}{N_2}$$

The ratio of primary turns to secondary turns is referred to as the turns ratio, represented by:

$$\frac{N_1}{N_2}$$

Current is also affected by the turns ratio of a transformer, but in reverse to voltage, so:

$$\frac{V_1}{V_2} = \frac{N_1}{N_2} = \frac{I_2}{I_1}$$

EXAMPLE

A transformer is wound with 560 turns on the primary and 20 turns on the secondary. Suppose that 230 V AC is applied to the primary winding. Calculate the output voltage.

$$\frac{V_1}{V_2} = \frac{N_1}{N_2}$$

Then:

$$\frac{230}{V_2} = \frac{560}{20}$$

So:

$$V_2 = \frac{230 \times 20}{560} = 8.21 \text{ V}$$

If the secondary current is 4 A, calculate the input primary current.

$$\frac{N_1}{N_2} = \frac{I_2}{I_1}$$

Then:

$$\frac{560}{20} = \frac{4}{I_1}$$

So:

$$I_1 = \frac{4 \times 20}{560} = 0.14 \text{ A}$$

ACTIVITY

Try these calculations with different combinations of primary and secondary turns or voltages.

Transformer power ratings

As a transformer is not a load, simply a method of changing voltage and current, it is rated in kVA. This is because certain loads may include a power factor, which can increase the current demand by the load. As a result, the rating of the transformer is given in volt amperes (VA) instead of kilowatts (kW). So when selecting a transformer for a particular load, the actual current drawn by the load must be multiplied by the voltage.

ELECTRICAL CIRCUITS, SYSTEMS AND EQUIPMENT

Current behaves differently depending on the type of load connected to an AC circuit. Some loads cause current to lag and some lead where others keep the current in unity with the voltage. Where leading or lagging currents exist, so too does power factor. This section looks at how properties of a circuit change in AC systems.

Relationship between resistance, inductance, capacitance and impedance

Different components have different effects on AC circuits; these effects vary with frequency, depending on the components in the circuit. Other factors, such as resistance, have no effect on the waveform except to resist current flow.

INDUSTRY TIP

Ohm's law states that the current flowing in a circuit is proportional to the applied voltage and inversely proportional to the resistance.

Resistance

When a resistor is used in an AC circuit, the voltage drop and the current through the resistor are in phase, as the resistor has no effect on the circuit voltage or current, other than to restrict current flow proportionally to the voltage. The sinusoidal voltages and currents have no phase shift and are described as being 'in phase'. This in-phase or *unity* relationship can be understood using Ohm's law for the voltage and current:

$$V = I \times R$$

As there is no phase shift effect, there is no requirement in a resistive circuit to include the power factor. Resistive loads in AC circuits include items such as incandescent lamps, water heater (immersion) elements and electric kettles. Any load that relies on current passing through a material and producing heat is resistive.

The relationship between the voltage, current and resistance in an AC circuit is shown below with the circuit diagram (Figure 2.25) and the phasor diagram (Figure 2.26) and sine wave (Figure 2.27), together with the appropriate formula.

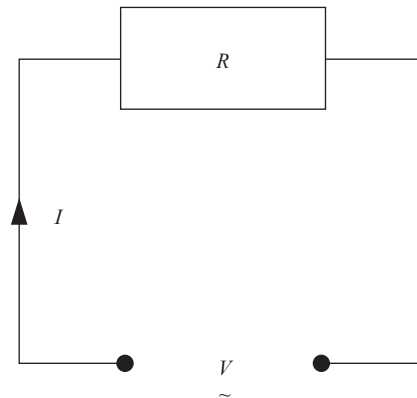

▲ Figure 2.25 Relationship between voltage, current and resistance as shown by a circuit diagram

Figure 2.25 shows the resistor connected to an AC supply.

INDUSTRY TIP

A phasor always rotates anti-clockwise.

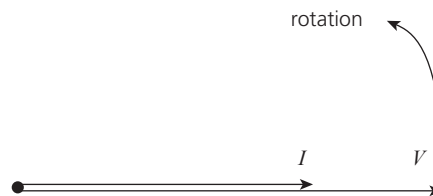

▲ Figure 2.26 Relationship between the voltage and current as shown by a phasor diagram (not to scale)

The phasor diagram (Figure 2.26) shows the relationship between the voltage and current. As the voltage and current are together, they are in phase or unity.

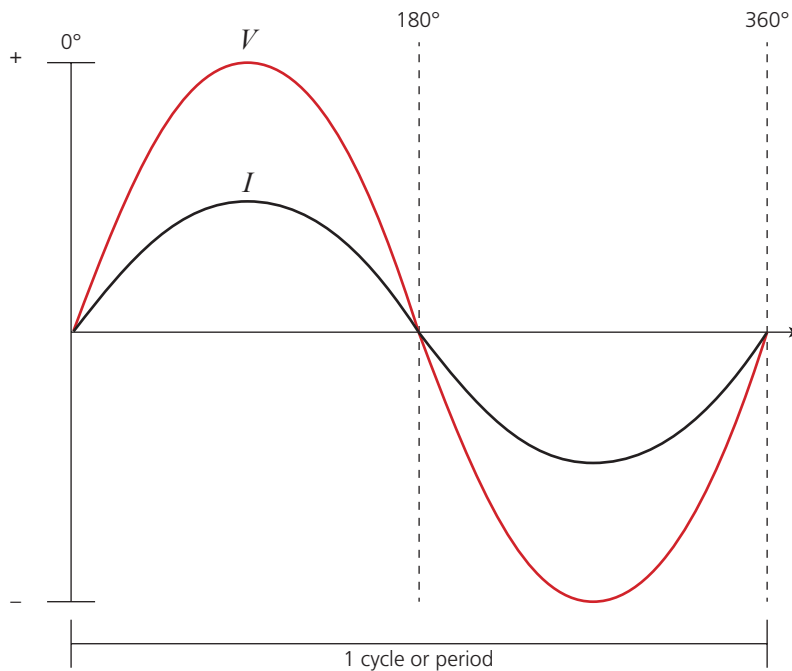

▲ Figure 2.27 Relationship between voltage and current as shown by a waveform

The sine wave (Figure 2.27) shows the voltage and current rising and falling at the same time. In AC circuits involving resistance only, Ohm's law applies as:

$$V = I \times R$$

Inductance

An inductor is a length of wire; sometimes this is a longer wire wound into a coil with a core of iron or air. An inductor is a component, such as a solenoid or field winding in a motor or a ballast unit in a fluorescent luminaire, that induces (produces) magnetism. Inductance is proportional to the inductor's opposition to AC current flow.

- The symbol for inductance is L .
- The unit of inductance is the henry (H).

As inductance increases and all other factors, such as frequency, remain the same, AC current flow reduces. This opposition to AC current flow is indicated as an increase in inductive reactance X_L .

We will assume that an inductor in a circuit produces pure inductance but this is actually impossible; as an inductor is a coiled wire, it also has resistance.

A pure inductance, as shown in the circuit diagram in Figure 2.28, will create a phase shift that causes the current to lag behind the voltage by 90° .

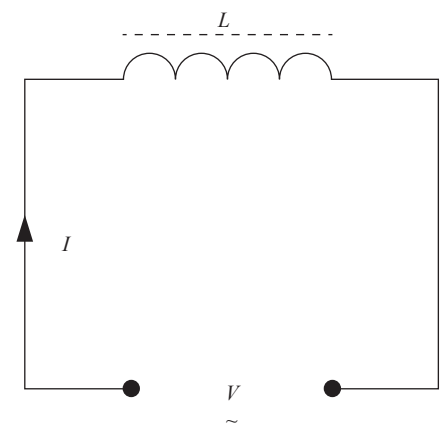

▲ Figure 2.28 An inductor in a circuit

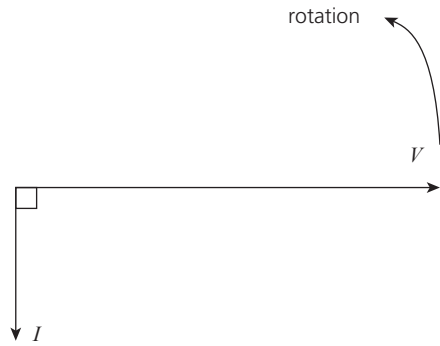

▲ Figure 2.29 Phasor diagram showing phase shift (not to scale)

The phasor diagram (Figure 2.29) shows the phase shift. When the phasor is rotated in the direction shown, the voltage leads the current or, as we normally say, the current *lags* behind the voltage. If the inductance was pure, this lag would be 90°. We shall explore how to create a phasor diagram later in this chapter.

ACTIVITY

A sine wave or sinusoidal wave can be plotted using sine values from 0 to 360° and multiplying the sine of the angle by the peak voltage.

Using a calculator, find the voltage values from 0 to 360° and plot a sine wave in which the peak voltage is 100 V.

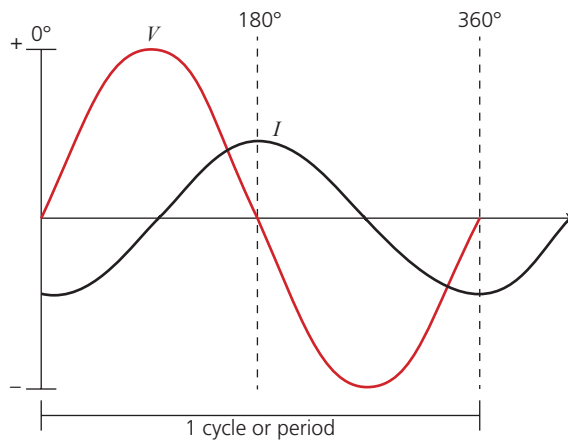

▲ Figure 2.30 Sine wave diagram showing phase shift

If you look at the lagging current sine wave, you will see that the current does not begin its cycle until the voltage is 90° into its cycle. Where the voltage begins its negative half-cycle, the current is still in a positive cycle – meaning the two values are reacting to one another. This is known as reactance, X , measured in ohms (Ω). As the reactance is linked to an inductor, we call this inductive reactance (X_L).

The reactance in the circuit can be determined using the value of inductance (L) in henries (H) and the frequency of the supply (f) measured in hertz (Hz). So

$$X_L = 2\pi fL$$

ACTIVITY

Calculate the current drawn by a 240 mH inductor connected to a 230 V 400 Hz supply.

EXAMPLE

Determine the reactance when an inductance of 40 mH is connected to a 230 V 50 Hz supply.

As:

$$X_L = 2\pi fL$$

then:

$$X_L = 2\pi \times 50 \times 40 \times 10^{-3} = 12.57 \Omega$$

If the inductance is pure, the reactance replaces resistance in Ohm's law so:

$$I = \frac{V}{X_L}$$

So using the example above, the value of circuit current would be:

$$I = \frac{230}{12.57} = 18.3 \text{ A}$$

Assuming the inductance to be pure, this current would lag the voltage by 90° . Remember, however, that the inductance cannot be pure as the coil or winding is made up of a conductor which has resistance. We shall study the effect of resistance on an inductor later in this chapter.

Capacitance

A capacitor is a device that is used to store and discharge energy. It does not contain a resistance so it does not dissipate energy. A capacitor *can* be pure. Capacitors are used in circuits for many reasons; most commonly, capacitors are found in electrical installations for power factor correction purposes. Capacitance (C) is measured in farads (F) – usually expressed in micro-farads. One micro-farad (μF) is one-millionth (10^{-6}) of a farad.

A capacitor has the opposite effect to an inductor when connected to an AC circuit; it causes the current to lead the voltage by 90° .

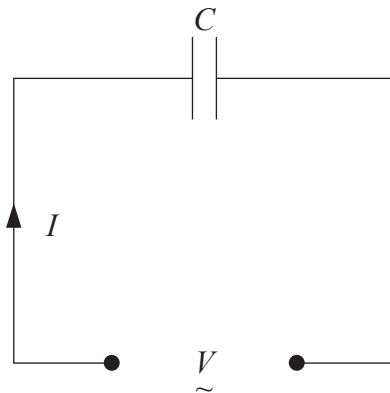

▲ Figure 2.31 Circuit diagram with capacitor

The capacitor produces a reactance. This reactance, known as capacitive reactance (X_C), affects current flow.

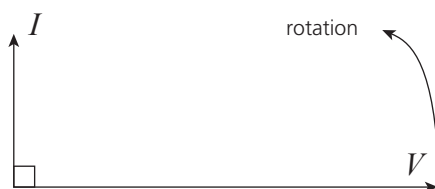

▲ Figure 2.32 Phasor diagram showing the effects of a capacitor (not to scale)

INDUSTRY TIP

The amount of energy stored in a capacitor is very small. In a typical fluorescent capacitor it is about 0.1 J.

The phasor diagram shows that the current leads the voltage by 90° in the direction of rotation.

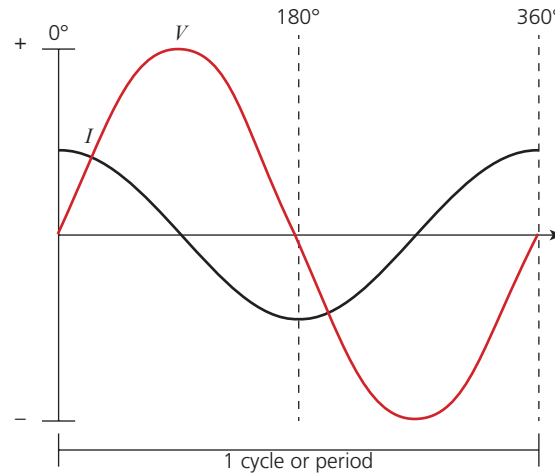

▲ Figure 2.33 Sine wave diagram showing phase shift due to a capacitor

The sine wave diagram (Figure 2.33) shows the current leading the voltage and, once again, the current and voltage are reacting. At various points in the cycle there will be reactance.

The capacitive reactance of a capacitive circuit can be determined, using:



$$X_c = \frac{1}{2\pi fC}$$

EXAMPLE

Determine the reactance when a 120 μF capacitor is connected to a 230 V 50 Hz supply.

As:

$$X_c = \frac{1}{2\pi fC}$$

then:

$$X_c = \frac{1}{2\pi \times 50 \times 120 \times 10^{-6}} = 26.53 \Omega$$

Where the capacitance is pure (that is, no other components are connected in that part of the circuit), then X_c replaces resistance in Ohm's law.

Determine, using the example above, the current drawn by the capacitor.

ACTIVITY

By multiplying the instantaneous values of voltage and current, the power wave can be achieved.

Plot your own waveform.

So as:

$$I = \frac{V}{X_C}$$

then:

$$I = \frac{230}{26.52} = 8.7 \text{ A}$$

Impedance

Impedance is the product of a circuit that has both resistance and reactance (inductive, capacitive, or both). Resistance causes unity and reactance causes a leading or lagging current, but as a circuit cannot have two currents, the resulting current will fall between the two, as shown in Figures 2.34 and 2.35.

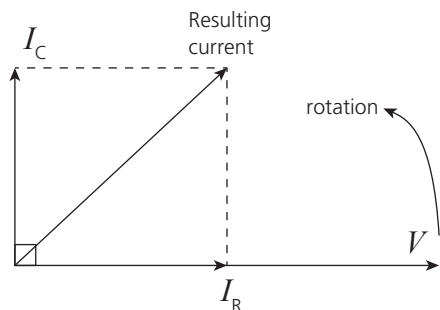

▲ Figure 2.34 Phasor diagram showing a leading current due to a capacitor and resistor in the circuit (not to scale)

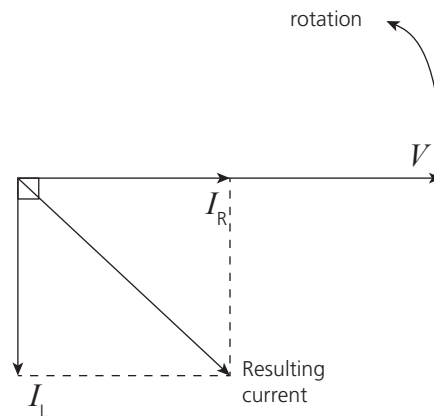

▲ Figure 2.35 Phasor diagram showing the resultant lagging current due to the inductor and resistor in the circuit (not to scale)

This current is determined by using the circuit impedance (Z) measured in ohms.

Impedance can be determined by:

$$Z = \sqrt{R^2 + X^2}$$

The value of reactance (X) depends on the component used, so if an inductance is connected with an impedance, X_L is used and for capacitance X_C is used.

Where a circuit contains both, the resulting reactance is used; this is the smallest value subtracted from the largest.

INDUSTRY TIP

Most loads are either resistive (heaters and tungsten lamps) or a mixture of resistive and inductive.

HEALTH AND SAFETY

A two-core cable has capacitance as it consists of two plates (conductors) and a dielectric (insulation). Some cables can store a charge after an insulation test is carried out then discharge through the first person to touch the cores.

EXAMPLE

Determine the impedance if a circuit contained a 30 Ω resistor, an inductor having a 12.56 Ω reactance and a capacitor having a 26.52 Ω reactance.

The total reactance is:

$$X = X_C - X_L$$

as the capacitive reactance is the larger value.

So as:

$$Z = \sqrt{R^2 + X^2}$$

then:

$$Z = \sqrt{30^2 + (26.52 - 12.56)^2} = 33.09 \Omega$$



Impedance triangle

The relationship between the different components in a circuit can be explored using an impedance triangle, as shown in Figure 2.36.

IMPROVE YOUR MATHS

Make sure you draw the impedance triangle the right way round, depending on whether the current is leading or lagging.

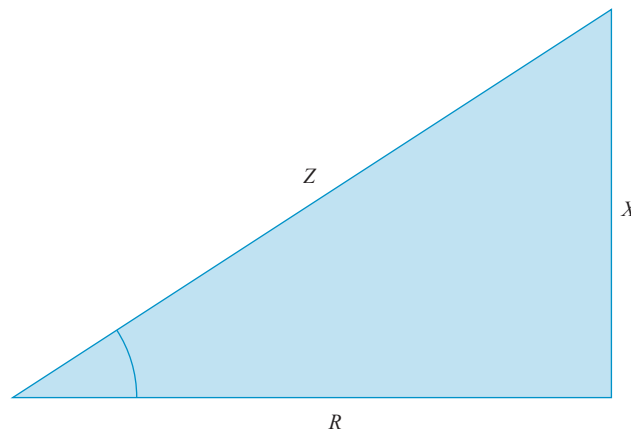

▲ Figure 2.36 Impedance triangle

Using the triangle and Pythagoras' theorem, we can see that the impedance value alters depending on the values of resistance or impedance. Impedance triangles are drawn to scale. If the value of reactance increases or decreases, this affects the angle between the resistance (R) and impedance (Z). We shall explore this relationship later in this chapter when we look at power factor.

CALCULATE UNKNOWN VALUES IN AC CIRCUITS

Components in AC circuits can be arranged in series, parallel or in combination. Each configuration has different effects on circuit properties.

Series connected circuits (RL series)

When an inductor is connected into a circuit, we considered earlier in this chapter that the inductor has pure inductance. This, in reality, is not possible as the conductor that is used to form the inductor's coil has a resistance. These two properties are in series with one another. As with DC circuits, if components are connected in series, the current is constant (that is, it is the same through each component), but the voltage changes as it is 'lost' across each component, creating voltage drop or a potential difference.

The circuit shown in Figure 2.37 has the following values:

$$R = 40 \Omega$$

$$L = 38 \text{ mH}$$

$$\text{Supply} = 230 \text{ V } 50 \text{ Hz}$$

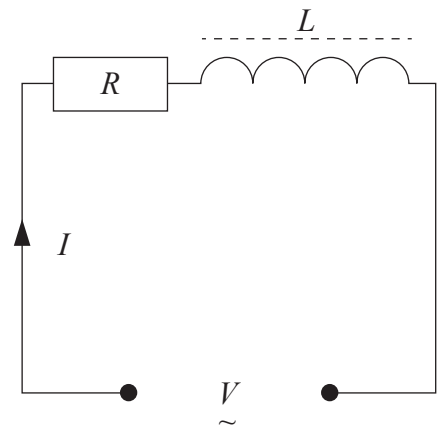

▲ Figure 2.37 Components connected in series

EXAMPLE

Determine:

- the inductive reactance (X_L)
- the impedance (Z)
- the total circuit current (I)
- the value of voltage across each component (V_R) and (V_L).

a As $X_L = 2\pi fL$ then $X_L = 2 \times \pi \times 50 \times 38 \times 10^{-3} = 11.94 \Omega$

b As $Z = \sqrt{R^2 + X^2}$ then $Z = \sqrt{40^2 + 11.94^2} = 41.74 \Omega$

c As $I = \frac{V}{Z}$ then $I = \frac{230}{41.74} = 5.51 \text{ A}$

- d** The value of voltage across each component part is determined from Ohm's law:

$$V_R = I \times R \quad \text{so} \quad V_R = 5.51 \times 40 = 220.4 \text{ V}$$

$$V_L = I \times R_L \quad \text{so} \quad V_L = 5.51 \times 11.93 = 65.73 \text{ V}$$

As you can see, the two voltages do not add up to the supply voltage of 230 V. This is because the supply voltage would be the phasor sum of the two values as each component reacts differently to AC current.

We can determine the phasor sum in two ways, by calculation (using Pythagoras' theorem) or by constructing a phasor to represent the two components.

Determining the phasor sum by calculation

$$V_{\text{supply}} = \sqrt{V_R^2 + V_L^2}$$

so

$$V_{\text{supply}} = \sqrt{220.4^2 + 65.73^2} = 229.99 \text{ V or } 230 \text{ V}$$



ACTIVITY

Calculate the current drawn by a $10 \mu\text{F}$ capacitor when connected to a 230 V 50 Hz AC supply.

Constructing a phasor

As we have seen, a phasor diagram is a representation of the component values in an AC circuit and how the components lead or lag. Also, it shows the resulting supply characteristics.

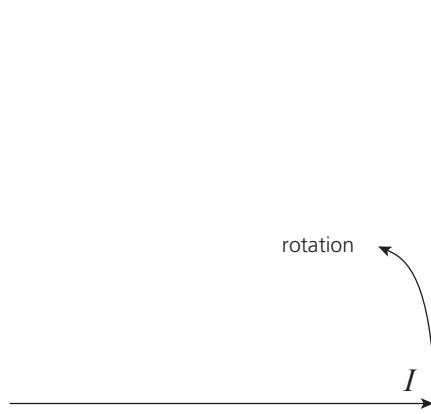

▲ Figure 2.38 Constructing a phasor; using a reference line

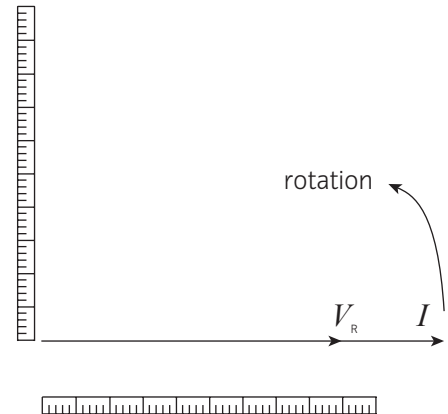

▲ Figure 2.39 Drawing a phasor using a scale

To construct a phasor, we must first decide on a reference line (Figure 2.38). In a series circuit the common component is current as it is the same throughout the circuit; in a parallel circuit, this would be voltage. With exception to the reference line, phasor diagrams must be drawn using a suitable scale.

Once a reference line is drawn, the line representing the voltage across the resistor is drawn. As this voltage is in unity to the current, this line is plotted on the reference line (Figure 2.39).

Then we add the value of the inductor voltage to the same scale.

As the current lags in an inductive circuit, the voltage V_L is drawn upwards. This is to show that the current (reference line) lags the voltage (given the direction of rotation). As we must assume this component to be pure, the line is drawn 90° from the reference line (Figure 2.40).

Then we construct a parallelogram from the two voltage values (Figure 2.41).

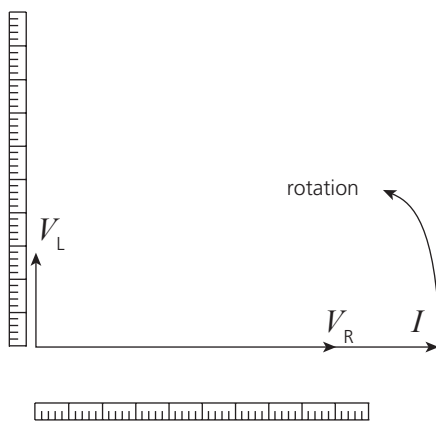

▲ Figure 2.40 Drawing the voltage value

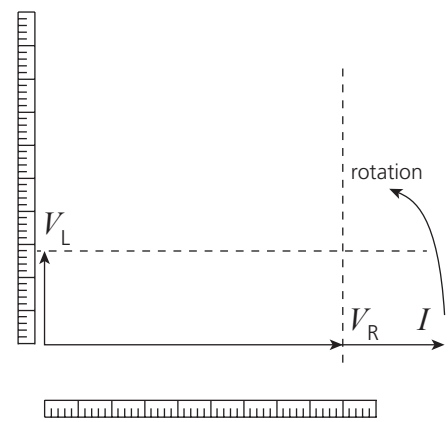

▲ Figure 2.41 Constructing a parallelogram

Finally, the resulting supply voltage is drawn in, connecting the origin to the point where the two sides of the parallelogram intersect (Figure 2.42). The length of this line, to the scale used, represents the supply voltage V_S .

We can see from the phasor that the current lags behind the supply voltage by a particular angle less than 90° – the resistance acts against the pure inductance, meaning the current lag is not fully 90° .

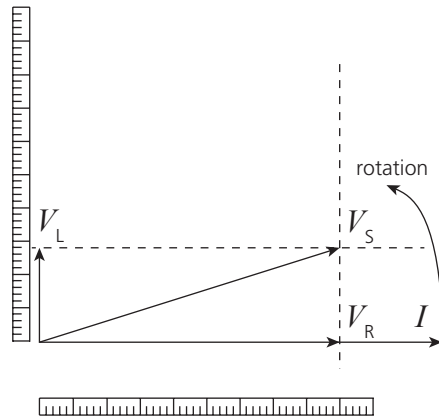

▲ Figure 2.42 Drawing in the supply voltage

RLC series circuits

If a circuit contains all three components, as in the circuit shown in Figure 2.43, the components behave differently as the circuit current changes.

The circuit shown in Figure 2.43 has the following values:

$$R = 40 \, \Omega$$

$$L = 38 \, \text{mH}$$

$$C = 120 \, \mu\text{F}$$

$$\text{Supply} = 230 \, \text{V} \, 50 \, \text{Hz}$$

EXAMPLE

Determine:

- the inductive reactance (X_L)
- the capacitive reactance (X_C)
- the impedance (Z)
- the total circuit current (I)
- the value of voltage across each component (V_R), (V_L) and (V_C).

a As $X_L = 2\pi fL$ then $X_L = 2 \times \pi \times 50 \times 38 \times 10^{-3} = 11.94 \, \Omega$

b As $X_C = \frac{1}{2\pi fC}$ then $X_C = \frac{1}{2 \times \pi \times 50 \times 120 \times 10^{-6}} = 26.53 \, \Omega$

INDUSTRY TIP

In an RLC series circuit where the inductive and capacitive reactance cancel each other out, $R = Z$ and the power factor is 1 (unity). The current is V/R . High voltage may appear across the reactive components.

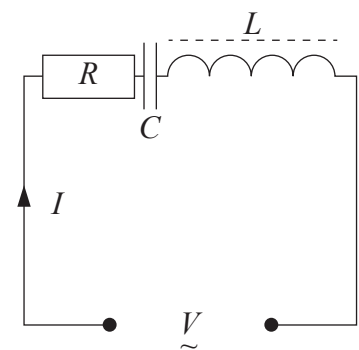

▲ Figure 2.43 RLC circuit containing all three components

ACTIVITY

A capacitor and inductor each of 200Ω reactance are connected in series to a 115Ω resistor. What is the voltage across the capacitor if the supply voltage is 230 V ?

c As $Z = \sqrt{R^2 + X^2}$ and $X = X_C - X_L$ then
 $X = X_C - X_L = 26.53 - 11.94 = 14.59 \Omega$

So $Z = \sqrt{40^2 + 14.59^2} = 42.58 \Omega$

d As $I = \frac{V}{Z}$ then $I = \frac{230}{42.58} = 5.4 \text{ A}$

e The value of voltage across each component part is determined from Ohm's law:

$V_R = I \times R$ so $V_R = 5.4 \times 40 = 216 \text{ V}$

$V_L = I \times X_L$ so $V_L = 5.4 \times 11.94 = 64.48 \text{ V}$

$V_C = I \times X_C$ so $V_C = 5.4 \times 26.53 = 143.26 \text{ V}$

Once again, we could prove the circuit supply voltage by calculation or phasor.

Determining the phasor sum by calculation

$V_{\text{supply}} = \sqrt{V_R^2 + V_X^2}$ where $V_X = V_C - V_L$

Once again, subtract the smallest value from the largest:

$V_X = 143.26 - 64.48 = 78.78 \text{ V}$

So

$V_{\text{supply}} = \sqrt{216^2 + 78.78^2} = 229.9 \text{ or } 230 \text{ V}$



Constructing a phasor

We construct the phasor as before, but this time we insert the voltage across the capacitor before we construct the parallelogram. Remember, as the current leads the voltage in a capacitor, the voltage lags the reference line (in the downwards direction) by 90° .

Following this, we take the smallest value of voltage in the capacitor or inductor from the largest, just as in the calculation, so we end up with a resulting voltage V_X from which the parallelogram may be formed.

We can see that the current now leads the voltage by a particular angle as the capacitor is the stronger component.

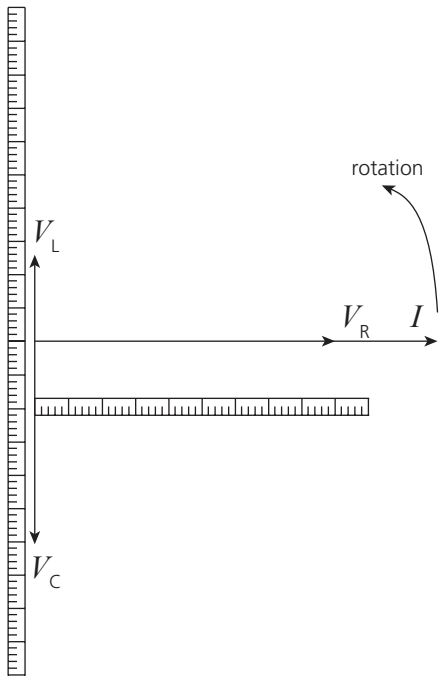

▲ Figure 2.44 Constructing a phasor for an RLC circuit (the rulers are an indicator of length)

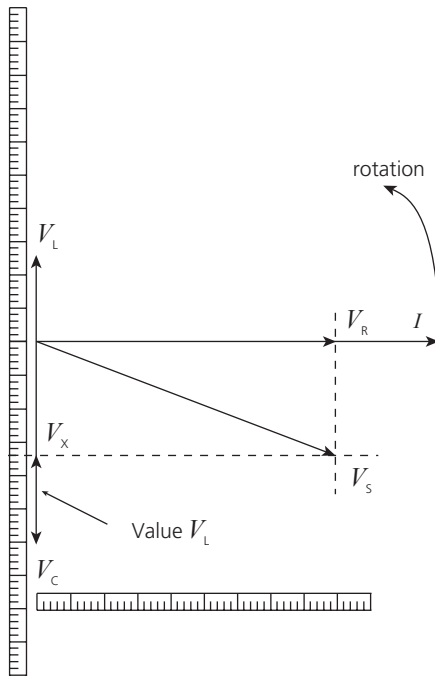

▲ Figure 2.45 Forming the parallelogram (the rulers are an indicator of length)

Components in parallel

When components are connected in parallel, the voltage becomes the common component and current is split through each component.

The circuit shown in Figure 2.46 has the following values:

$$R = 40 \Omega$$

$$C = 120 \mu\text{F}$$

$$\text{Supply} = 230 \text{ V } 50 \text{ Hz}$$

EXAMPLE

Determine:

- the capacitive reactance X_C
- the value of current through each component
- the total circuit current.

a As $X_C = \frac{1}{2\pi fC}$ then $X_C = \frac{1}{2 \times \pi \times 50 \times 120 \times 10^{-6}} = 26.53 \Omega$

b $I_R = \frac{V}{R}$ so $I_R = \frac{230}{40} = 5.75 \text{ A}$

c $I_C = \frac{V}{X_L}$ so $I_C = \frac{230}{26.53} = 8.67 \text{ A}$

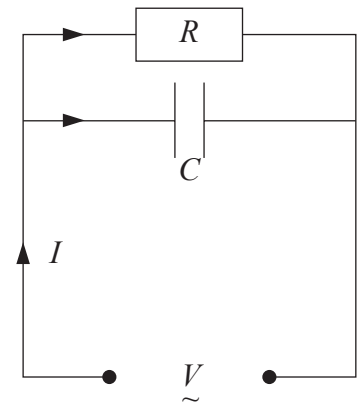

▲ Figure 2.46 Components in parallel

In the same way as we did for voltage, we can prove the circuit supply current by calculation or phasor.

Proving the circuit supply current by calculation

$$I_{\text{supply}} = \sqrt{I_R^2 + I_X^2}$$

So

$$I_{\text{supply}} = \sqrt{5.75^2 + 8.67^2} = 10.40 \text{ A}$$



Constructing a phasor

Once again, drawn to a suitable scale, the phasor is used to determine the supply current. Notice that, this time, the voltage is the reference line as it is common to all components. As the capacitor is the component, the supply current ends up leading.

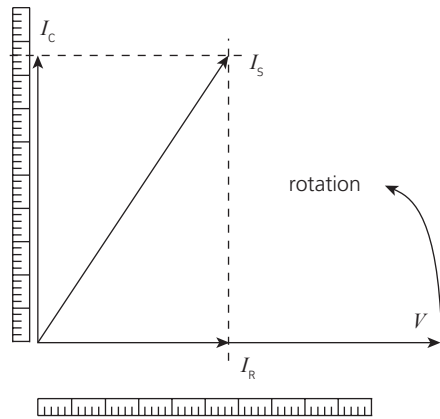

▲ Figure 2.47 Constructing a phasor for a parallel circuit

Circuits with both series and parallel components

In practice, in electrical installations, electricians are more likely to come across circuits where the inductor and resistor are in series, such as in motor winding or in the choke/ballast in a fluorescent luminaire, and the capacitor is in parallel for power factor correction purposes.

In this situation, the current in the series section of the circuit is determined using impedance and the capacitor is determined using capacitive reactance.

The circuit shown in Figure 2.48 has the following values:

$$R = 12 \Omega$$

$$L = 88 \text{ mH}$$

$$C = 150 \mu\text{F}$$

$$\text{Supply} = 230 \text{ V } 50 \text{ Hz}$$

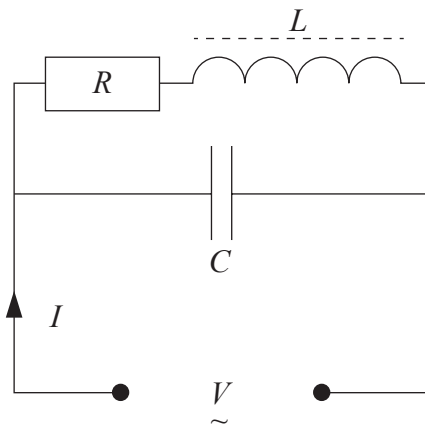

▲ Figure 2.48 Circuit with components in both series and in parallel

Example calculation

First, we determine the inductive reactance:

$$X_L = 2\pi fL$$

so:

$$X_L = 2\pi \times 50 \times 88 \times 10^{-3} = 27.65 \Omega$$

and:

$$Z = \sqrt{R^2 + X_L^2}$$

so:

$$Z = \sqrt{12^2 + 27.65^2} = 30.14 \Omega$$



ACTIVITY

R and L in series with C in parallel is a typical power factor correction arrangement. It is not usually required to correct to unity power factor. Research why power factor isn't normally corrected to unity.

The current in the inductive/resistive section of the circuit is:

$$I = \frac{V}{Z}$$

so:

$$I = \frac{230}{30.14} = 7.63 \text{ A}$$

The current drawn by the capacitor is based on the capacitive reactance:

$$X_C = \frac{1}{2\pi fC}$$

so:

$$X_C = \frac{1}{2\pi \times 50 \times 150 \times 10^{-6}} = 21.22 \Omega$$

therefore as:

$$I = \frac{V}{X_C}$$

then:

$$I = \frac{230}{21.22} = 10.84 \text{ A}$$

Showing this as a phasor to determine the total current requires a slightly different approach than before; we need first to construct a phasor using the series circuit values, then draw in the capacitance values. Before we do this, we need to understand how power factor affects the circuit and, therefore, the resulting phase angle.

INDUSTRY TIP

Remember that, when an inductor or capacitor causes the current to lead or lag the voltage, at various points in the sine wave the voltage and current are in opposition and, therefore, are reacting (giving reactance).

POWER FACTOR AND THE POWER TRIANGLE

When the concept of power was explored at Level 2, the relationship between voltage and current was described as:

$$P = V \times I$$

If a load was purely resistive, this would be true. However, as many AC circuits have impedances and capacitors, the power behaves differently as an element of the power is dissipated, due to the reactance of the circuit.

Power triangle

In power terms, this reactive part of the circuit (together with the true power relationship) can be explained using a power triangle.

As we can see, a resistive load gives the true power. The reactive (capacitive or inductive) load creates the reactive power element that affects the overall impedance. This is the apparent power.

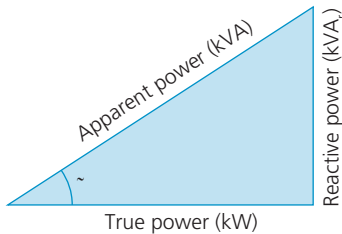

▲ Figure 2.49 The true power relationship expressed in a power triangle

Therefore, having a reactive component in the load creates an apparent power. This draws more current from the load than if this was a purely resistive load. The apparent load is measured in volt-amperes (VA) or kilovolt-amperes (kVA). We can also see that an angle forms between the true power and apparent power. The cosine of this angle gives the power factor for the circuit or load.

So in order to determine the true power of a circuit we must apply this equation:

$$\text{true power (watts, W)} = V \times I \times \cos \theta$$

From this, we could also state:

$$\text{power factor } \cos \theta = \frac{\text{true power}}{\text{apparent power}} \quad \text{or} \quad \frac{\text{kW}}{\text{kVA}}$$

Like a phasor, a power triangle could help us to determine appropriate values of capacitance to improve the power factor.

INDUSTRY TIP

kVA_r stands for reactive kilovolt-amperes.

ACTIVITY

Make a list of five items in a domestic installation that would have an inductive component in the load.

INDUSTRY TIP

kVA_r is useless power due to the reactance and True Power (kW) is the useful power that drives the equipment. What you pay for is the result of the two, the apparent power (kVA).

 **Example calculation**

A 230 V 4 kW motor has a power factor rating of 0.4. Determine a suitably sized capacitor to improve the power factor to 0.85. Supply frequency is 50 Hz.

Let us first work out some values to see the extent of the problem.

If we ignore reactance and, therefore, power factor, this motor should draw a current of:

$$\frac{4000 \text{ W}}{230 \text{ V}} = 17.4 \text{ A}$$

But in reality, because of power factor, it draws a current of:

$$\frac{4000 \text{ W}}{230 \text{ V} \times 0.4} = 43.5 \text{ A}$$

So, you can see that the reactance in the circuit causes the motor to draw 43.5 A instead of 17.4 A. This is a huge difference. By installing a correctly sized capacitor into the circuit, we could improve this, reducing the overall current demand. As the motor is an inductive load causing the current to lag, a capacitor will draw the current back towards unity and, therefore, closer to the value of true power.

To work out the size of capacitor needed, we need to determine the amount of reactive power the capacitor consumes. Remember, this reactive power drawn by the capacitor doesn't increase overall power demand, it simply off-sets the reactance caused by the impedance as it draws the current towards leading and, therefore, reducing reactance.

To determine the amount of reactive power, we need to draw a power triangle to show the relationship before correction.

Using a suitable scale, we draw true power to represent 4 kW. Then we measure an angle from this of $\cos^{-1} 0.4 = 66.4^\circ$.

The line from this angle represents the apparent power. We then draw a line at 90° from the other end of the true power line. This line represents the reactive power. The two lines meet to form the power triangle, as seen in Figure 2.50.

As we need to improve power factor to 0.85, we need to measure another angle from the true power line at $\cos^{-1} 0.85 = 31.79^\circ$ (32°). This line represents the new apparent power following correction, and gives a value by which reactance must be reduced.

By measurement, this line represents 6.6 kVA_r , that needs to be off-set so:

$$\frac{\text{kVA}_r \times 1000}{V} = I_c$$

so:

$$\frac{6.6 \times 1000}{230} = 28.70 \text{ A}$$

So, we need a capacitor that will theoretically draw a current of 28.70 A.

Then we need to carry out some of the previous calculations in reverse.

So:

$$\text{as } I_c = \frac{V}{X_C} \text{ then } X_C = \frac{V}{I_c} \text{ so } \frac{230}{28.70} = 8.01 \Omega$$

And then:

$$X_C = \frac{1}{2\pi fC} \text{ so } C = \frac{1}{2\pi fX_C} = \frac{1}{2\pi \times 50 \times 8.01} = 398 \times 10^{-6}$$

A $398 \mu\text{F}$ capacitor is needed.

INDUSTRY TIP

The power factor of a motor depends on the load. Off-load the power factor is poor but this improves as the load increases. Any capacitor calculation should be based on the expected load (or consult the manufacturer).

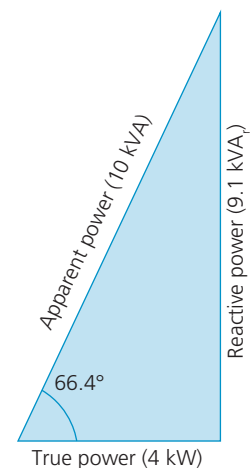

▲ Figure 2.50 Power triangle for example calculation (not to scale)

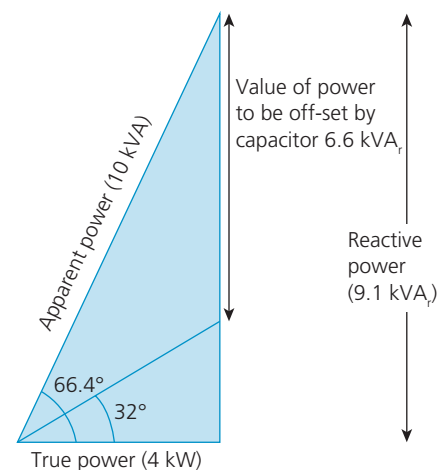

▲ Figure 2.51 Power triangle showing correction of power factor (not to scale)

ACTIVITY

Use your calculator to find the cosine of 1°, 10°, 30°, 45°, 70° and 90°. Can you see that the greater the angle, the smaller the factor; the smaller the angle, the closer the factor is to 1, or unity?

If you reverse the process and choose a factor, you can determine the angle by using the \cos^{-1} feature on your calculator. Try $\cos^{-1} 0.75$.

INDUSTRY TIP

A power factor cannot go beyond 0.00 (which represents 90°) as any current that lags by more than 90° becomes a leading current.

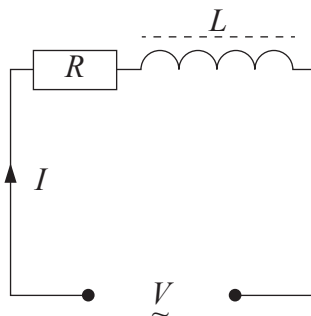

▲ Figure 2.52 We will calculate power factor for this RL series circuit

IMPROVE YOUR MATHS

\cos^{-1} is evaluated on most calculators by pressing the shift or 2nd key before the cos button. Look at your calculator to see if \cos^{-1} is written above the cos key. What colour is it written in and what colour is the shift key?

Power factor

The power factor is defined as the cosine of the angle by which the current leads or lags the voltage ($\cos \theta$). The power factor does not have a unit of measurement as it is a factor. The value can range from 0.01 to 0.99. A power factor of 1 is unity, the same as having a resistive circuit where the current rises and falls in phase with the voltage.

Power factors are used to express the effect of leading and lagging currents and many machines have a power-factor rating stated on the rating plate. The value is used to determine the current demand of the machine. As circuits with leading or lagging currents introduce reactance, this creates the effect of additional loading and, therefore, additional current demand in a circuit. We need to understand and allow for this additional load when selecting equipment and cables for a circuit or installation.

Calculating power factor

To determine the values of the power factor at circuit level, we can apply the following equation:

$$\text{power factor} = \cos \theta = \frac{R}{Z}$$

The circuit shown in Figure 2.52 has the following values:

$$R = 40 \Omega$$

$$L = 38 \text{ mH}$$

$$\text{Supply} = 230 \text{ V } 50 \text{ Hz}$$

EXAMPLE CALCULATION

Determine:

- the inductive reactance (X_L)
- the impedance (Z)
- the total circuit current (I)
- the power factor and angle by which the current lags the voltage.

a As $X_L = 2\pi fL$ then $X_L = 2 \times \pi \times 50 \times 38 \times 10^{-3} = 11.94 \Omega$

b As $Z = \sqrt{R^2 + X^2}$ then $Z = \sqrt{40^2 + 11.94^2} = 41.74 \Omega$

c As $I = \frac{V}{Z}$ then $I = \frac{230}{41.74} = 5.51 \text{ A}$

d As the power factor $= \cos \theta = \frac{R}{Z}$ then $\cos \theta = \frac{40}{41.74} = 0.958$

So if the power factor is 0.958, the angle by which the current lags the voltage (inductive circuit) is:

$$\cos^{-1} 0.958 = 16.7^\circ$$

Power factors and impedance triangles

Power factors can also be determined from impedance triangles as the angle formed by the R and Z lines represents the angle by which the current leads or lags the voltage. The cosine of this angle is the power factor.

We shall look again at power factors once we have looked at values of power quantities in the next section.

In an earlier example (page 96), we examined a circuit with components in series and in parallel. Here is the circuit again.

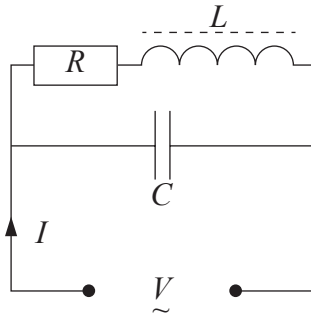

▲ Figure 2.54 Circuit with components in series and in parallel

Recall the information given for this circuit:

$$R = 12 \Omega$$

$$L = 88 \text{ mH}$$

$$C = 150 \mu\text{F}$$

$$\text{Supply} = 230 \text{ V } 50 \text{ Hz}$$

As we have previously determined:

$$X_L = 2\pi fL$$

so:

$$X_L = 2\pi \times 50 \times 88 \times 10^{-3} = 27.65 \Omega$$

and:

$$Z = \sqrt{R^2 + X_L^2}$$

so:

$$Z = \sqrt{12^2 + 27.65^2} = 30.14 \Omega$$

The current in the inductive/resistive section of the circuit is:

$$I = \frac{V}{Z}$$

so:

$$I_z = \frac{230}{30.14} = 7.63 \text{ A}$$

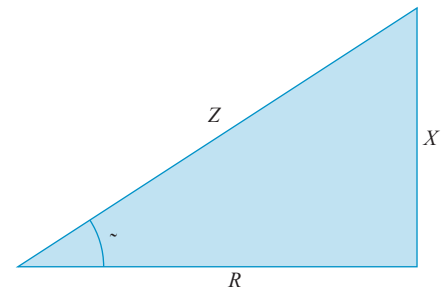

▲ Figure 2.53 Using an impedance triangle to calculate the power factor

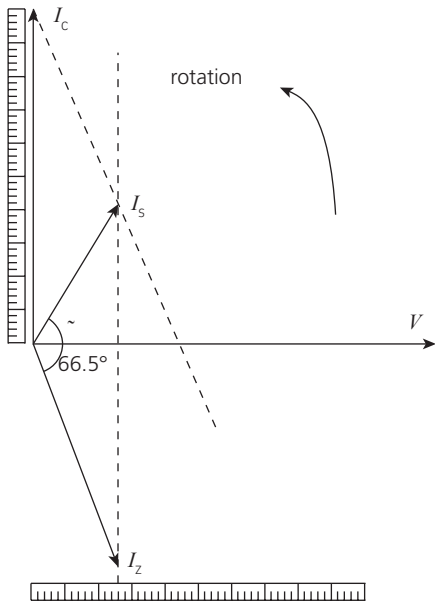

The current drawn by the capacitor is based on the capacitive reactance:

$$X_C = \frac{1}{2\pi fC}$$

so:

$$X_C = \frac{1}{2\pi \times 50 \times 150 \times 10^{-6}} = 21.22 \Omega$$

As:

$$I = \frac{V}{X_C}$$

then:

$$I_C = \frac{230}{21.22} = 10.84 \text{ A}$$

▲ Figure 2.55 Calculating power factor with a phasor, ensuring you use a suitable scale

We can now go on to determine the power factor and angle of the lagging current in the series branch of the circuit in order to construct our phasor.

As the power factor = $\cos \theta = \frac{R}{Z}$

then $\cos \theta = \frac{12}{30.14} = 0.398$

So the angle is $\cos^{-1} 0.398 = 66.55^\circ$ lagging (inductive circuit)

ACTIVITY

Construct this phasor to scale and measure the new supply current angle. From this angle, determine the power factor of the circuit.

We can construct the phasor, firstly, by showing that the current drawn by the impedance (series branch) part of the circuit lags the voltage reference line by 66.55° to a scale value of 7.63 A.

We can then add the capacitor in parallel, drawing 10.84 A and leading the voltage by 90° . Forming a parallelogram from these two points gives us the point from which to draw the supply circuit current. This should work out to be 4.8 A to scale. From this, we can also see the angle at which it leads the voltage. The cosine of this angle is the power factor of the circuit.

POWER FACTOR CORRECTION

The effect of poor power factor absorbs part of the capacity of the generating plant and the distribution system, and as such distribution network operators charge industrial users on a kVA rather than a kW basis. It is therefore desirable for these users to keep the power factor of installed equipment as high as is practically possible.

Where the power factor is excessively low, power factor correction equipment can be installed which will produce economic savings and, where equipment and cables are operating at maximum rating, reduce the loading to safe limits and avoid overheating. Reduction of the current means system losses are reduced and

improved voltage drop is usually obtained by the reduction in loading. Savings can also be made in cabling costs by improving the power factor.

In order to correct the power factor on the incoming supply it is necessary to measure it. The most convenient and easiest method of measuring power factor at any point in a circuit or installation is by means of a power factor indicator. If an indicator is not available an accurate calculation can be made by taking watt, volt and ampere measurement as shown in Figure 2.56.

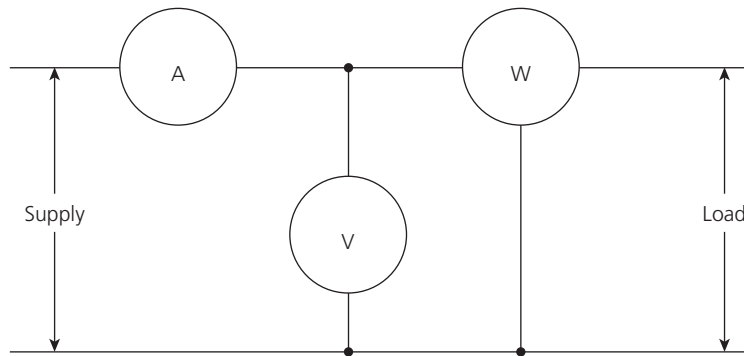

▲ Figure 2.56 Connection of instruments to calculate PF

The wattmeter is used to indicate true power (P in watts, W), whereas the volt and ammeter are used to calculate the apparent power (volt-amperes in VA).

Since:

$$PF = \frac{\text{true power}}{\text{apparent power}}$$

then the above connected meters will enable the PF to be calculated.

Methods of power factor correction

The equipment available for improvement of the power factor can be divided into two main groups:

- rotary, e.g. synchronous motors (although this system is rarely used today)
- stationary, e.g. capacitors.

Over-exciting a synchronous motor was often carried out in large factories during the postwar period to improve the overall power factor. Any large synchronous machines could be over-excited or run lightly to improve power factor. These motors would be used to supplement fixed banks of capacitors, which could be switched in to match the power factor throughout the day.

Correction by capacitors

The application of power factor correction capacitor banks is employed in electrical installations to correct the power factor.

This is due to the fact that most circuits are inductive in nature, which creates a lagging power factor. By adding power factor correction capacitors to the circuit, the kVA_r is reduced as the capacitive kVA_r cancels out the inductive kVA_r .

ACTIVITY

Power factor correction can be carried out by individual capacitors mounted at the load or by bulk correction at the intake. Name one advantage and one disadvantage of each arrangement.

INDUSTRY TIP

If too much capacitance is added, the result will be an increase in apparent power as a lagging current becomes a leading current.



▲ Figure 2.57 Larger automatic switchable unit

Power factor correction in many installations is achieved by a bank or banks of fixed capacitors. Alternatively, where the load changes or more accurate correction is required, power factor correction is achieved through automatically switched capacitors. Automatic switching units use monitoring technology to switch capacitors in and out of the load automatically as the load profile changes. These units are in banks, normally in multiples of 50kVA, so that the first bank of fixed capacitors deals with the base load. Remember that going too far with capacitors causes a leading power factor, which is again chargeable.

Therefore, it is ideal to balance the load and switch in capacitors throughout the changing load profile to ensure the PF stays around 0.95. These units are normally installed at or near the intake position in a building in order to deal with the overall power factor correction.

As well as using capacitor banks to correct power factor at source, the power factor may be corrected through the equipment. Installing suitably rated capacitors in parallel with a load improves the power factor. As an example, fluorescent luminaires contain capacitors for this reason. The capacitor is connected between line and neutral in the luminaire. If the capacitor is removed, the luminaire will still operate but it will draw slightly more current due to the power factor.

Load profiling

Load profiling is, quite simply, monitoring a supply to see times of demand. Most single-phase domestic installations can be easily monitored by using smart meter technology, giving real time usage statistics. Some data receiver units have the ability to store this data, thus giving a record of times of maximum and minimum consumption.

Using this data, load forecasting can then be undertaken which can anticipate times of excessive consumption and automatically turn off non-essential loads during these periods. This can be achieved by using smart technologies such as smart switches or electric car chargers that can draw electricity from the charged car instead of charging it. This stored energy can then be used to power other appliances. The car battery could then be re-charged at times of lower demand, such as overnight.

In situations where a dwelling both generates power to supply the grid as well as consuming power, it is known as a **prosumer** as it both produces and consumes.

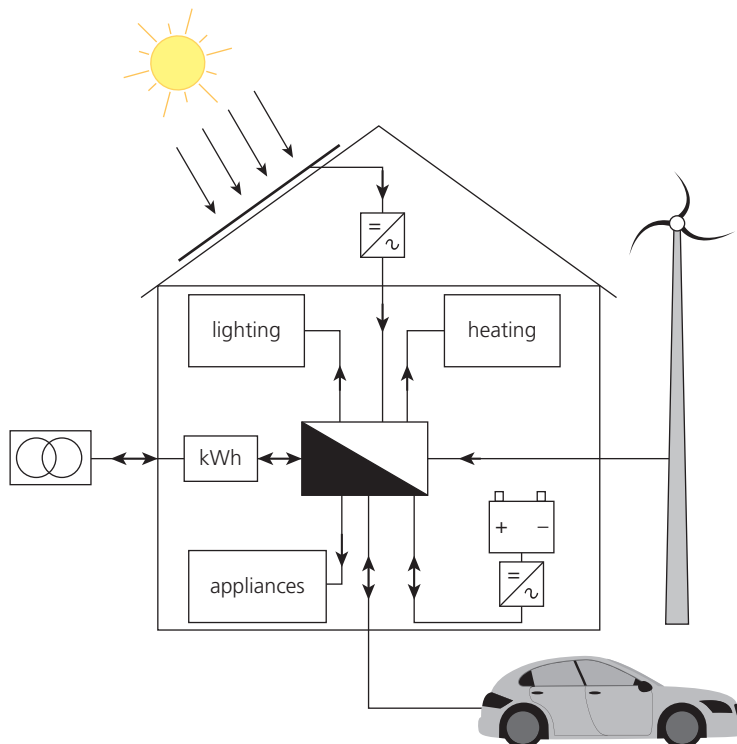

▲ Figure 2.58 A prosumer's installation which can consume energy from the public supply network as well as having its own generator or electricity storage systems

Less smart technologies like timeclocks can also be used to turn off non-essential loads during peak periods of demand.

NEUTRAL CURRENT IN THREE-PHASE AND NEUTRAL SUPPLIES

In a balanced three-phase system there is no requirement to have a star-point connection as the three phases have a cancellation effect on each other. Therefore the star point is naturally at zero current. While the load is balanced and the waveforms are symmetrical (not containing harmonics or other waveform

INDUSTRY TIP

A three-phase heater or motor would provide a balanced load. Three identical houses connected to separate single-phase supplies probably wouldn't as each would have a different load.

distorting influences), this statement is relatively accurate. However, in practice, this is sometimes not the case.

Where the load is not in balance, different currents circulate in the load through the source winding and back. This gives rise to a change in star-point voltage, which can result in the system 'floating' away from its earthed reference point. In essence, a current will flow in the neutral. The three ways in which this current value could be determined are:

- by phasor, an accurate method that indicates the angle at which the maximum current occurs
- by calculation, which gives an accurate value
- by equilateral triangle, which gives a good indication of the value.

Determining current value by phasor

Assuming that a load has the current values $L_1 = 85 \text{ A}$, $L_2 = 50 \text{ A}$ and $L_3 = 60 \text{ A}$ per phase, the current value can be determined by the following steps.

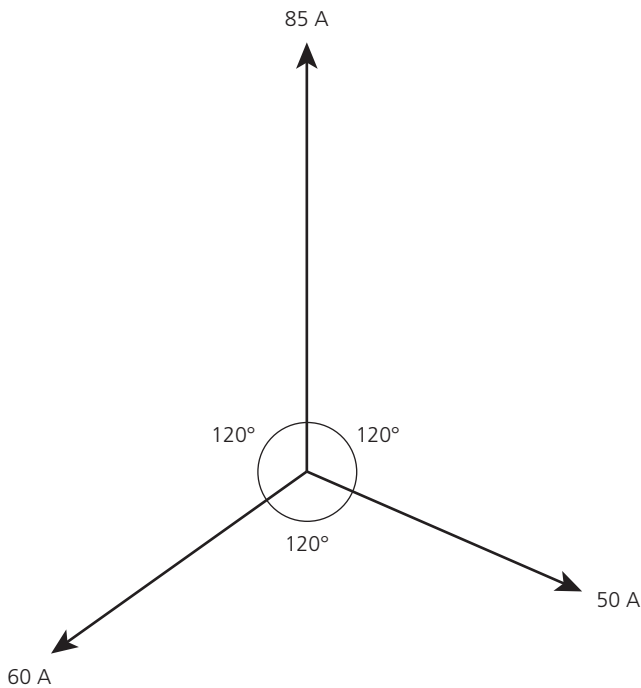

▲ Figure 2.59 Step 1 Construct a basic three-phase phasor to a suitable scale, ensuring the phases are 120° apart (not to scale)

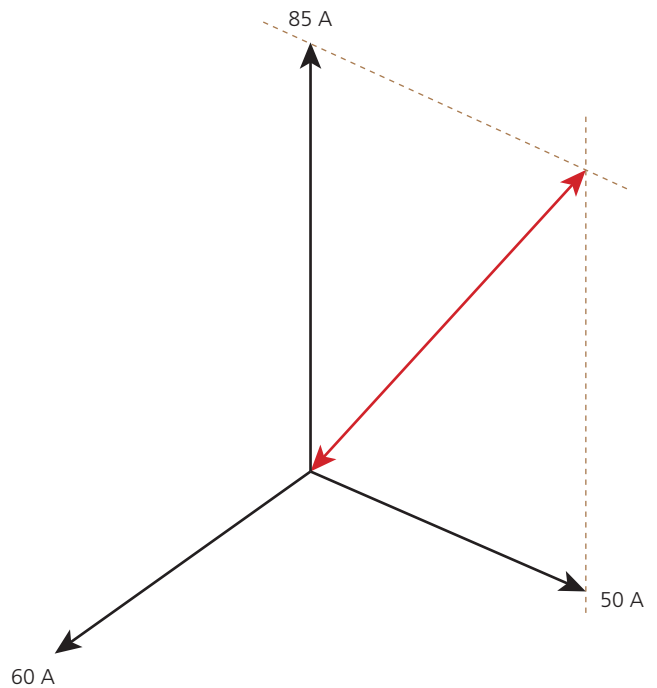

▲ Figure 2.60 Step 2 Construct a parallelogram with two of the phases and draw a line from the centre point of the phasor to the point where the two new lines meet

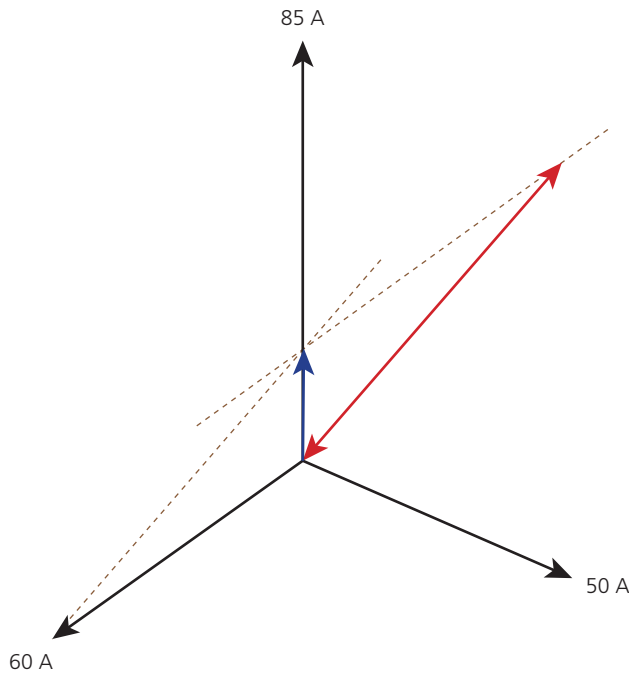

▲ Figure 2.61 Step 3 Now construct another parallelogram between the new line and the remaining phase. Where the two new parallelogram lines intersect represents the neutral current value to the scale selected

ACTIVITY

Three equal 40 A loads are connected in star to a 400 V supply. The neutral current is zero. What will be the neutral current if:

- a one phase is disconnected
- b two phases are disconnected?

Determining current value by equilateral triangle

The value of the neutral current can be determined using a scale drawing based on an equilateral triangle. If all phases are balanced, and therefore equal, all sides of the triangle are equal in length and meet to give equal angles of 60°.

If the phases are not balanced, there will be a gap at the top of the two sloping sides, which represents the neutral current. The triangle here represents a balanced system.

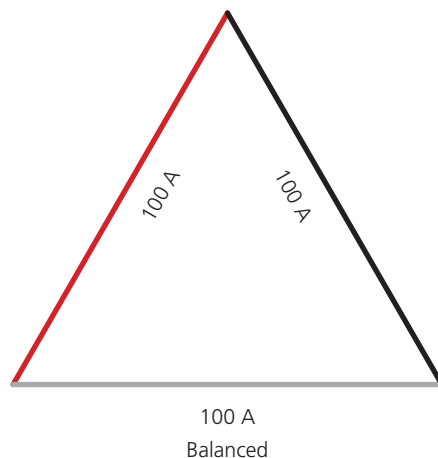

▲ Figure 2.62 A balanced system represented by an equilateral triangle

$$N = \sqrt{L_1^2 + L_2^2 + L_3^2 - (L_1 \times L_2) - (L_1 \times L_3) - (L_2 \times L_3)}$$

IMPROVE YOUR MATHS



Remember, an equilateral triangle is formed by three equal sides and has three equal angles of 60°.

INDUSTRY TIP

When constructing scaled diagrams, it is crucial that you use a good scale and measure accurately.

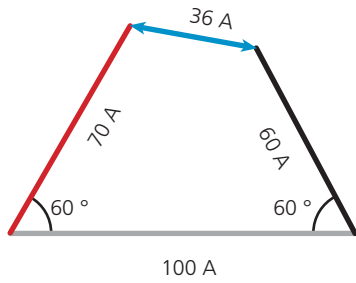

▲ Figure 2.63 In an unbalanced system, the gap (shown in light blue) represents the neutral current

Now consider an unbalanced system with these values:

- $L_1 = 70 \text{ A}$
- $L_2 = 100 \text{ A}$
- $L_3 = 60 \text{ A}$

Draw the diagram, using an appropriate scale to represent the three current values. See Figure 2.63.

$$N = \sqrt{70^2 + 100^2 + 60^2 - (70 \times 100) - (70 \times 60) - (100 \times 60)} = 36 \text{ A}$$

The neutral current is represented by the gap left where the two sides do not meet (shown in light blue). In this example, that gap represents a current of approximately 36 A.

VOLTAGE AND CURRENT IN STAR- AND DELTA-CONNECTED SYSTEMS

Star (Y) and delta (Δ) configurations are used throughout the building services industry. Each configuration has different characteristics in terms of voltage and current values. Calculation of these values is essential in modern electrical engineering.

ACTIVITY

For a star-connected system, calculate the phase voltage when the line voltage is: a) 400 V, b) 415 V, c) 11 kV, d) 110 V.

Voltage and current in star-connected systems

In a star (Y) connected load:

- the line current (I_L) flows through the cable supplying each load
- the phase current (I_p) is the current flowing through each load.

So:

$$I_L = I_p$$

and:

- the voltage between any line conductors is the line voltage (V_L)
- the voltage across any one load is the phase voltage (V_p)

so:

$$V_p = \frac{V_L}{\sqrt{3}} \text{ or } V_L = V_p \times \sqrt{3}$$

In a balanced three-phase system there is no need to have a star-point connection to neutral as the current drawn by any one phase is taken out equally by the other two. Therefore the star point is naturally at zero.

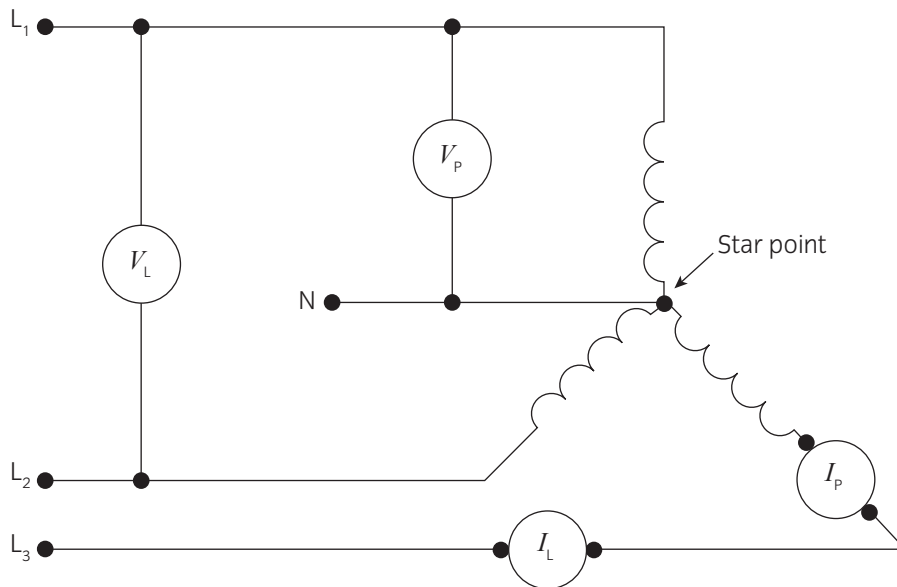

▲ Figure 2.64 Star-connected load

So if a line current is 10 A, the phase current will also be 10 A. If the line voltage was 400 V, the phase voltage would be:

$$\frac{400}{\sqrt{3}} = 231 \text{ V}$$

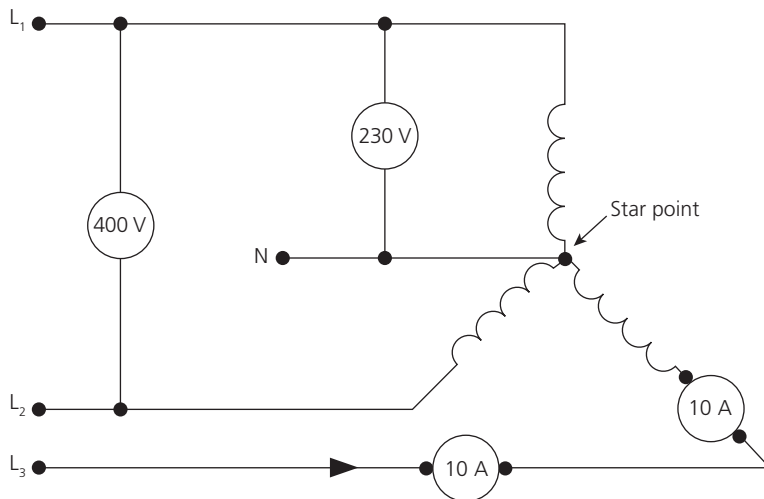

▲ Figure 2.65 Common phase and line currents in load

Voltage and current in delta-connected systems

In a delta (Δ) connected load:

- the line current (I_L) flows through the cable supplying each load
- the phase current (I_p) is the current flowing through each load.

So:

$$I_p = \frac{I_L}{\sqrt{3}} \text{ or } I_L = I_p \times \sqrt{3}$$

and:

- the voltage between any line conductors is the line voltage (V_L)
- the voltage across any one load is the phase voltage (V_p)

so:

$$V_L = V_p$$

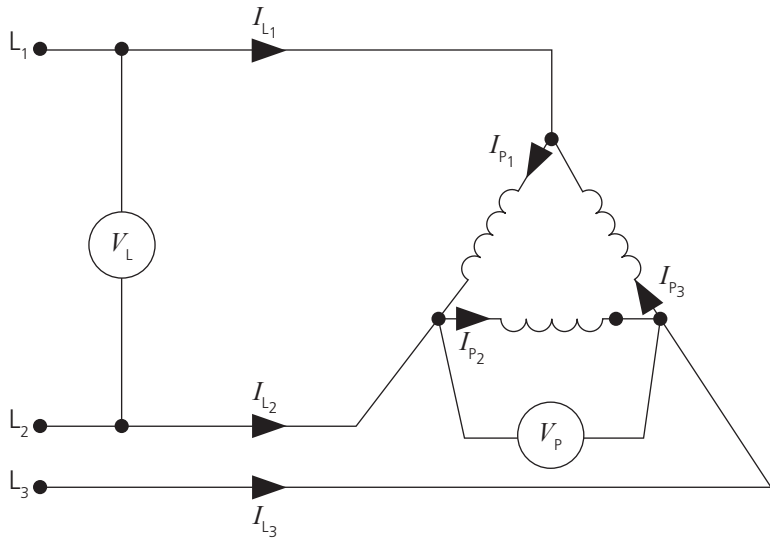

▲ Figure 2.66 Delta-connected load similar to delta-connected supply

As there is no provision for a neutral connection, items such as delta motors would automatically be balanced – but complex loads on transmission systems could be unbalanced.

INDUSTRY TIP

When we determine cable sizes, we use the line current to select a suitable cable current capacity.

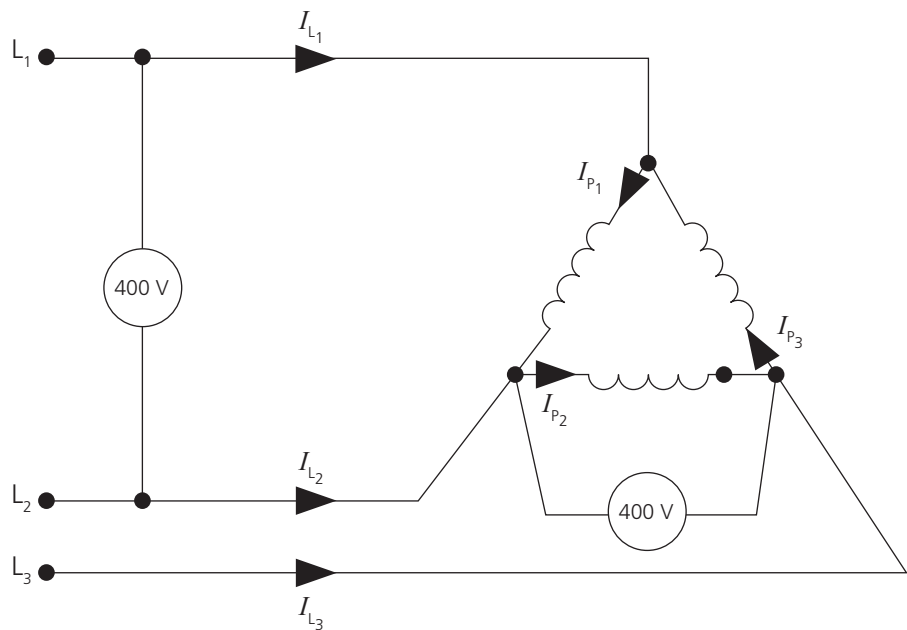

▲ Figure 2.67 Phase and line currents in the load

Therefore if the phase current is 100 A and the phase voltage is 400 V, the line current can be calculated as follows:

$$I_{\text{line}} = \sqrt{3} \times 100 = 173.2 \text{ A}$$

OPERATING PRINCIPLES AND APPLICATIONS OF DC MACHINES AND AC MOTORS

It is important to understand the differences in AC and DC machines and to appreciate where there are similarities in certain machine configurations.

How DC machines operate

Direct current (DC) machines were once the most popular type of machine because of the ability to control speed and direction. With advances in cheaper AC alternatives, and the fact that DC machines were more prone to wear, their use declined. Now that the parts and control devices for DC machines are cheaper, the use of DC is on the increase again. A skilled electrician must therefore have a knowledge of DC machine operating principles.

There is no difference in the construction of DC motors and generators. They are rotating machines with three basic features: a magnetic-field system, a system of conductors and provision for relative movement between the field and the conductors.

The magnetic field in most DC machines is set up by the stationary part of the machine, called the field windings. The rotating part, known as the armature, is made up of multiple loops of cable linked to a commutator. Power is either delivered to (motor) or taken from (generator) the armature by brushes in contact with the moving commutator.

DC generators

The DC generator is supplied with mechanical energy and gives out most of the energy, less losses, as electrical energy.

The DC generator has many loops and a multi-segmented commutator. With electricity flowing in the armature through brushes, the commutator reverses current flow as it passes from one pole to another so that the current in both conductors will always be the same.

When the loops within the armature are rotated within the magnetic field, an emf is induced into the loop. The use of a commutator ensures that the brushes are always in contact with the loop, which is in the strongest part of the magnetic field, at all times. This ensures a steady flow of direct current.

ACTIVITY

Losses occur in DC machines which reduce the efficiency. Name three such losses.

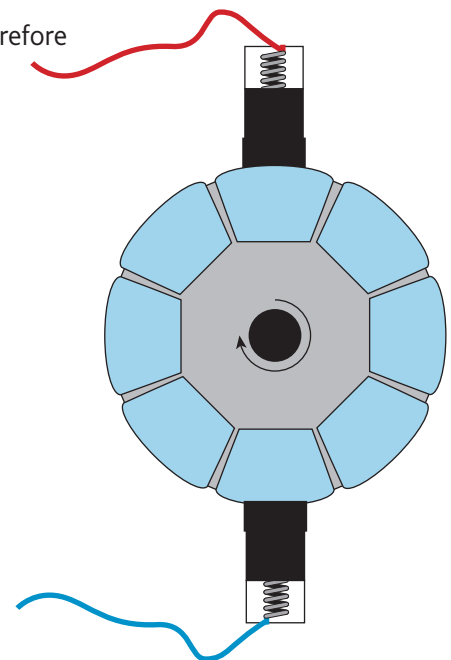

▲ Figure 2.68 A segmented commutator with carbon brushes making contact. This commutator would have four loops wound around the armature.

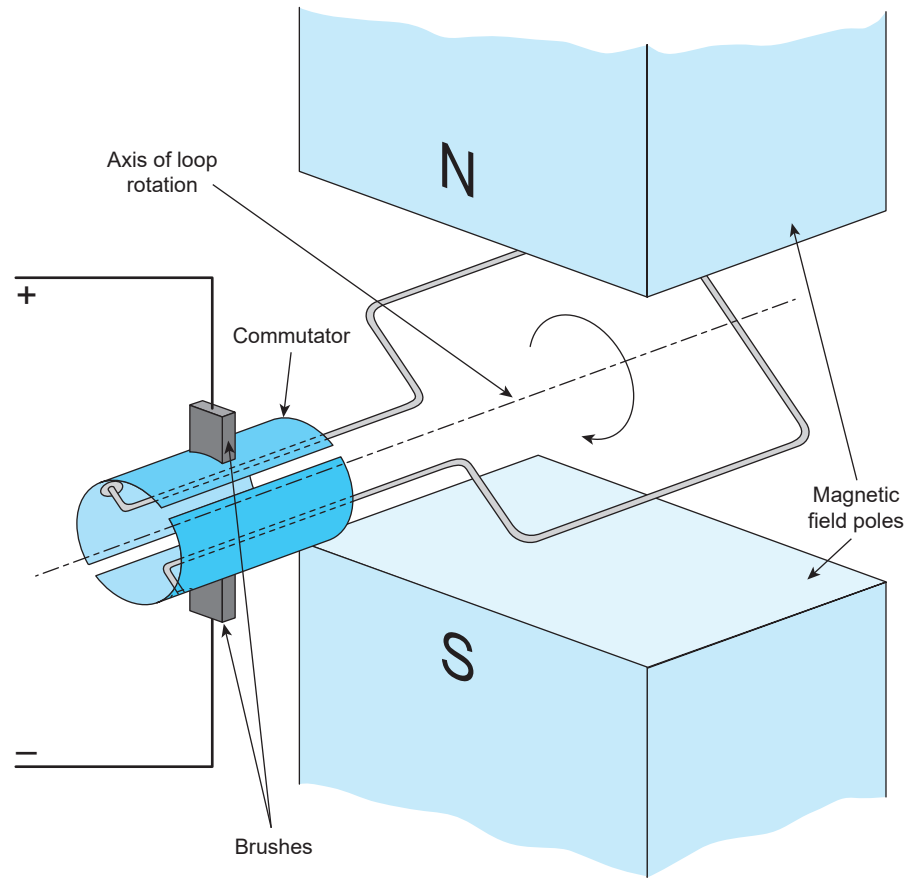

▲ Figure 2.69 A simple generator arrangement

INDUSTRY TIP

In the past, DC shunt generators were used in automobiles to keep the battery charged. In modern cars a three-phase alternator and bridge rectifier are used as this arrangement has a much higher output.

HEALTH AND SAFETY

Series machines should always be connected to a load, otherwise they will run dangerously fast.

DC motors

The DC motor takes in electrical energy and provides mechanical power, less losses.

There are three types of DC motor: series, shunt and compound.

Series motors

Series motors are also known as universal motors as they can be used on alternating current as well. The field and armature in a series motor carry the same current and are capable of providing high starting torques. As the current is common to both parts, the windings are heavy gauge.

Series motors can be reversed in direction if a switch device is inserted between the field and armature, allowing simple reverse polarity of either the field or armature, but not both at the same time.

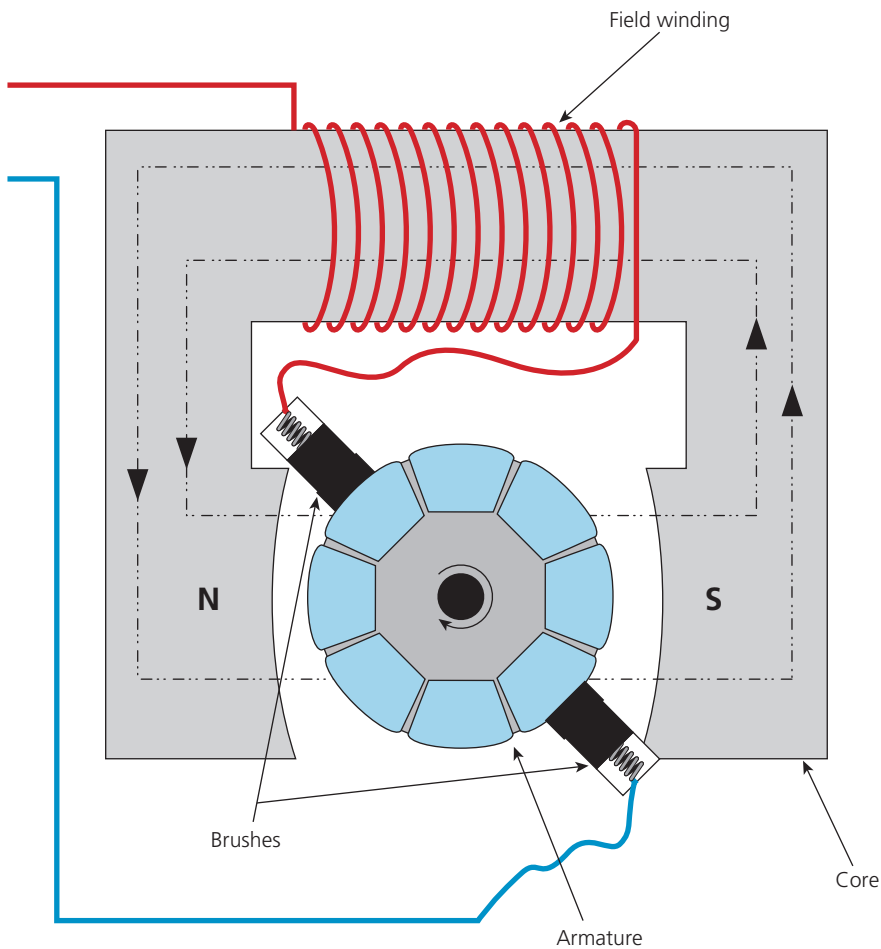

▲ Figure 2.70 Simplified series motor arrangement

Shunt motors

A shunt-connected DC motor consists of a field winding in parallel with the armature. This type of motor does not have the same common current characteristics as the series motor and therefore does not have a high starting torque. However, speed control of the shunt motor is considerably easier than the series motor as the field current can be controlled independently from the armature.

Shunt motors can be reversed in direction if the polarity of either the field or armature is reversed, but not both at the same time.

IMPROVE YOUR MATHS

The torque of a series motor is proportional to the current squared.

$$T \propto I^2$$

ACTIVITY

What is the difference between a self-excited and separately excited machine?

INDUSTRY TIP

The shunt motor uses a shunt field regulator to control the speed. Increasing resistance decreases the current and flux, causing the motor speed to increase.

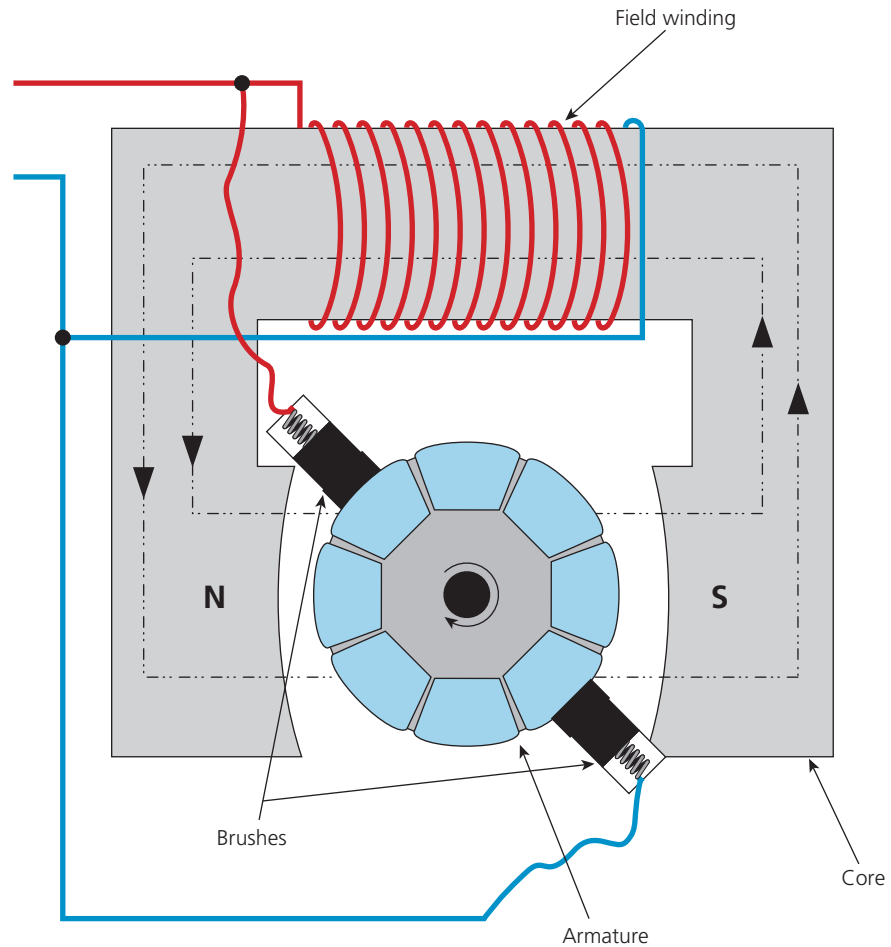

▲ Figure 2.71 Simplified shunt motor arrangement

Compound motors

The compound motor is a mixture of the series and shunt motor circuits, offering the benefits of each type of machine, i.e. high starting torque and good speed control. To reverse a compound motor, the armature field must be reversed.

INDUSTRY TIP

Compound machines can be 'long shunt' where the shunt winding is connected across the armature and series winding or 'short shunt' where the shunt winding is connected across the armature only.

A compound motor can be connected as a cumulative machine where the two fields assist each other or a differential machine where the two fields oppose each other.

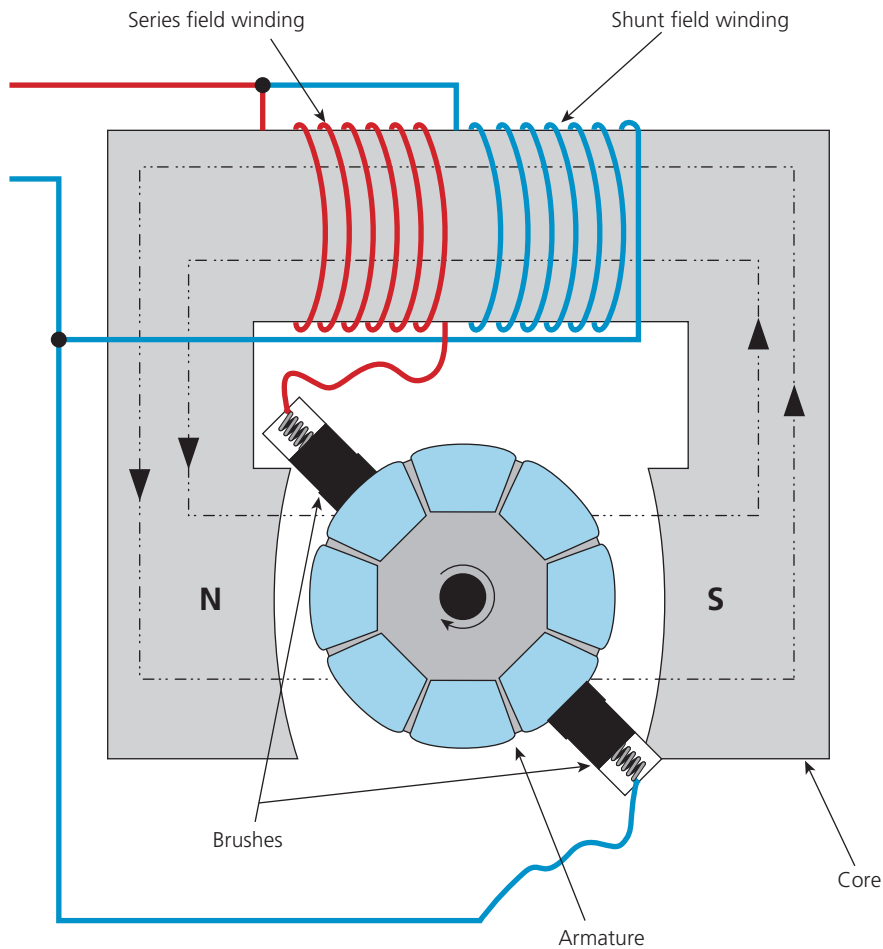

▲ Figure 2.72 Compound motor arrangement

Applications of DC machines

Series-wound motors have excellent torque (load) characteristics and are used for applications such as dragline excavators, where the digging tool moves rapidly when unloaded but slowly when carrying a heavy load.

Shunt motors are best used where constant speed and torque are to be maintained, for example, on a production line, so that items placed on it do not affect the speed.

Compound motors offer the benefits of both series and shunt motors and have been used in older underground trains.

Direct current generators do not have many practical uses in their own right. However, they can provide a reliable energy supply directly into batteries or where a DC supply is required.

How AC machines operate

The principle of operation for all AC motors relies on the interaction between a revolving magnetic field created in the stator by an AC current, with an opposing magnetic field either induced on the rotor or provided by a separate DC current source. This produces a torque that can be used to drive various loads.

The synchronous motor and induction motor are the most widely used types of AC motor. The difference between the two types of motor is that in a synchronous motor the rotation of the shaft is synchronised with the frequency of the supply current, and in an induction motor the rotor rotates slightly slower than the AC supply current in order to develop torque. The synchronous motor therefore operates at a precise speed.

How single-phase AC machines operate

A single-phase generator is composed of a single stator winding with one pair of terminals. With a single pair of rotating poles, the output waveform is as shown in Figure 2.73.

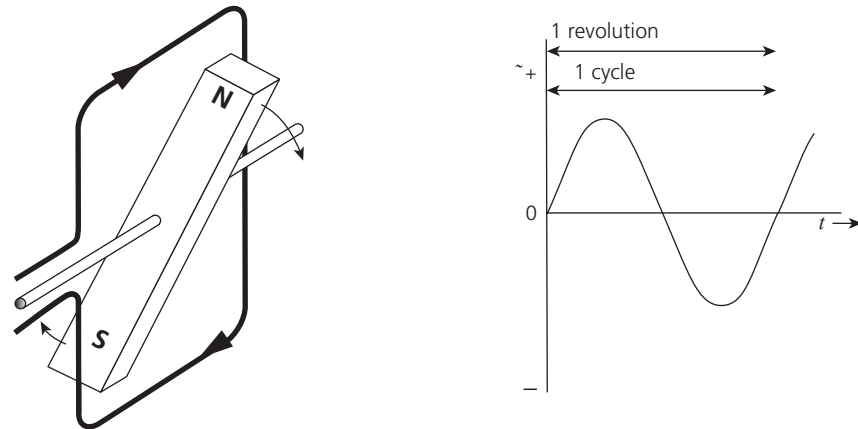

▲ Figure 2.73 Two-pole machine and output

When a four-pole machine is used, the output waveform is changed as follows.

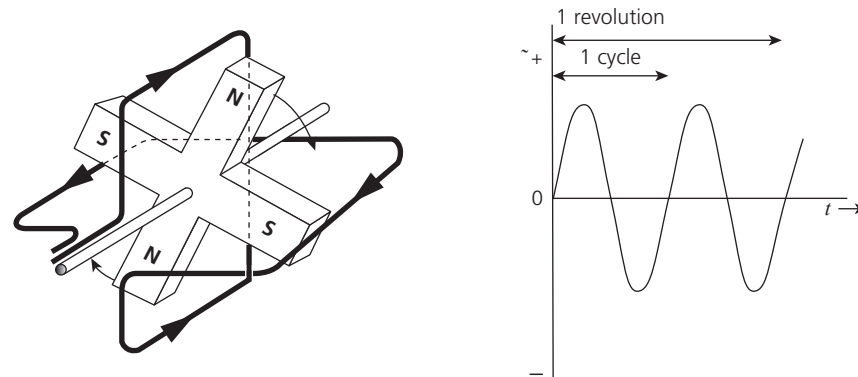

▲ Figure 2.74 Four-pole machine and output

How three-phase AC machines operate

Three-phase AC motors have a number of advantages over their single-phase equivalents, including:

- smaller physical size for a given output
- steady torque output
- the ability to self-start without additional equipment.

The induction motor is the simplest and most common form of motor. The stator consists of a laminated body with slots for the field windings to pass through. The rotor is a laminated cylinder with conducting bars just below the surface.

In its simplest form, the rotor consists of a number of conductors passing through holes in a rotor drum. The ends are brazed together, causing the formation of a cage, which is why it is called a cage rotor.

Cage induction motors are cheaper and smaller, but produce less torque, than wound rotor induction motors. Wound rotor motors provide speed control via resistors and slip rings, but this is an inefficient method of controlling speed.

How cage induction motors work

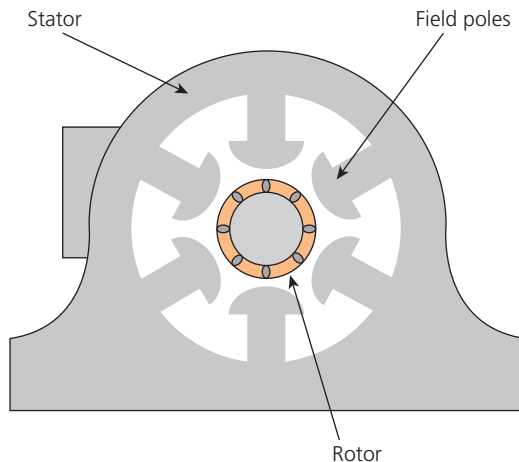

▲ Figure 2.76 Component parts of a six-pole cage induction motor

If a rotor is placed in the field set up by the field windings in the stator, it will be cut by alternate north and south fields as the field rotates through one cycle. This creates an emf in the rotor, which causes current to flow in the conductor bars of the rotor. This current flow sets up a magnetic field, which causes the rotor to move and follow the rotating magnetic field in the stator.

The rotor rotates faster, heading towards **synchronous speed**. However, as the rotor speed increases, the difference between **rotor speed** and stator field speed reduces, causing the emf induced to reduce. The reduction in torque reduces the acceleration/velocity, meaning that synchronous speed cannot be met because no field cuts the rotor and, in turn, no emf or current in the rotor is induced.

This means that **induction motors** reach an ideal balancing velocity where there is sufficient **slip** to ensure that an emf is generated, resulting in a torque to turn the rotor. The fundamental operating principle of induction motors is that there has to be slip for the motor to work.

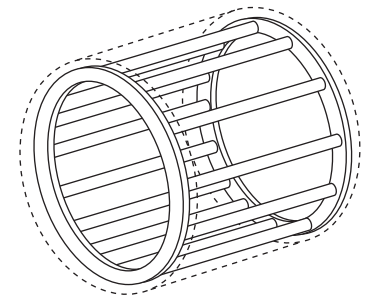

▲ Figure 2.75 Cage arrangement

INDUSTRY TIP

The three-phase coils set up a rotating magnetic field in the stator. This can be reversed by changing over any two supply phases, which in turn reverses the motor direction.

KEY TERMS

Synchronous speed:

The speed at which the rotating field rotates around the field poles.

Rotor speed: The actual speed at which the rotor rotates in revolutions/second (r/s).

Induction motor: The induction motor is the simplest form of alternating current (AC) motor. It is also known as the asynchronous motor.

Slip: The difference between the synchronous speed and the rotor speed expressed as a percentage or per unit value.

IMPROVE YOUR MATHS



Consider that a particular pole is north and that north then moves to the next pole (and the next) until there has been one complete rotation. The synchronous speed is the number of rotations completed in one second. The synchronous speed is affected by the supply frequency and the number of pairs of poles. For example, if a motor had six poles (three pairs) and the supply frequency was 50 Hz, the synchronous speed would be:

$$\text{synchronous speed } (n_s) = \frac{f}{p} = \frac{50}{3} = 16.67 \text{ r/s}$$

Slip may be represented as a percentage or a factor. If a motor with a synchronous speed of 16.67 revolutions/second had a slip of 8%, the rotor speed would be:

$$\begin{aligned} \text{rotor speed } (n_r) &= \text{synchronous speed} - \left[\frac{\text{synchronous speed} \times \text{slip percentage}}{100} \right] \\ &= 16.67 - \left[\frac{16.67 \times 8}{100} \right] \\ &= 15.34 \text{ r/s} \end{aligned}$$

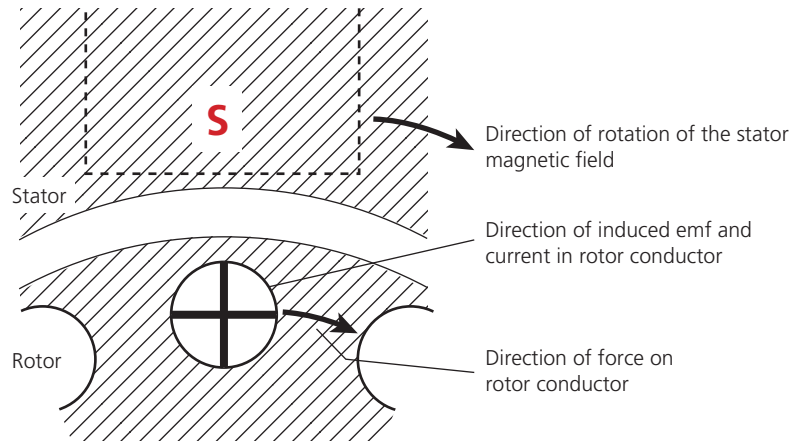

▲ Figure 2.77 Induction motor principles

ACTIVITY

A three-phase AC alternator has four poles per phase. Calculate the speed in revs/sec needed to produce an output of:

- a 40 Hz
- b 50 Hz
- c 60 Hz.

The speed of an induction motor can be varied by switching field pole pairs in and out.

EXAMPLE



Calculate the synchronous speed of a two-, a four- and a six-pole motor fed from a 50 Hz supply.

For a two-pole motor = one-pole pair:

$$n_s = \frac{f}{p} = \frac{50}{1} = 50 \text{ r/s}$$

For a four-pole motor = two-pole pair:

$$n_s = \frac{f}{p} = \frac{50}{2} = 25 \text{ r/s}$$

For a six-pole motor = three-pole pair:

$$n_s = \frac{f}{p} = \frac{50}{3} = 16.67 \text{ r/s}$$

It can be seen that the speed of a motor is varied by the number of poles. However, electronic controls, such as inverter drives, are more effective and allow the speed to be varied over a wide range, matching it to the load requirements.

Wound rotor induction motors

In wound rotor induction motors, the rotor windings are connected through slip rings to external resistances. Adjusting the resistance allows control of the speed/torque characteristic of the motor by controlling the flow of induced current in the rotor. These motors can be started with low inrush current by inserting high resistance into the rotor circuit; as the motor accelerates, the resistance can be decreased. The mains supply to this motor is connected to the field windings.

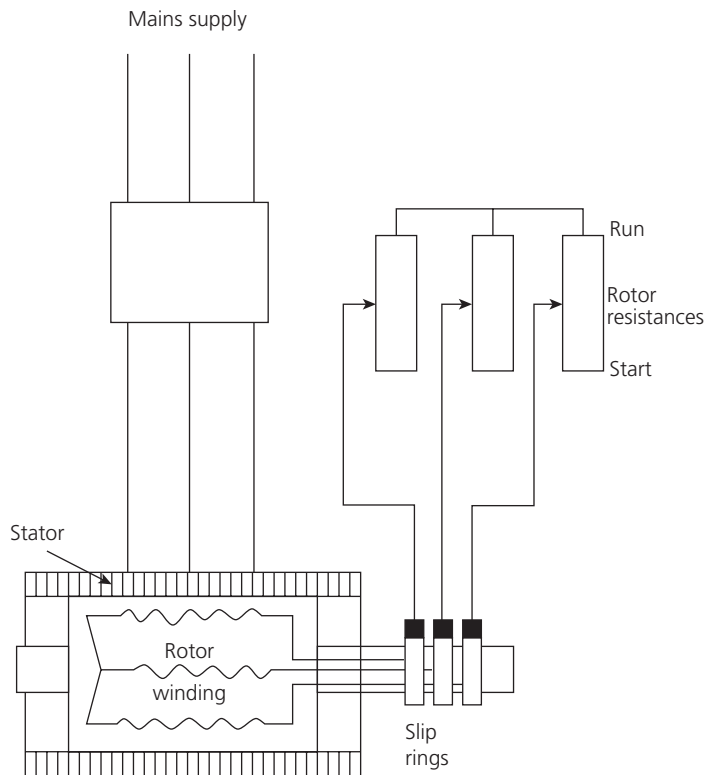

▲ Figure 2.78 Wound rotor arrangement

The use of simple induction motors with readily available variable frequency drives means the wound rotor motor is less common, as changing the frequency will also affect the synchronous speed and therefore the rotor speed.

Where a process does not require a motor to run at full speed, a variable frequency drive (VFD) can be used to reduce the frequency and voltage to meet the requirements of the motor's load. Other names for a VFD are variable speed drive, adjustable speed drive, adjustable frequency drive, AC drive, microdrive and inverter.

Single-phase induction motors

As we have seen, three-phase motors use one phase to induce current into the rotor bars, with another phase, at a different polarity, creating the repulsion/attraction. However, the single-phase motor will not start by itself. This is due to the magnetic flux components being equal and opposite, cancelling out and

INDUSTRY TIP

The control circuit needs interlocks to prevent the motor being started with the resistance out of circuit (run position).

INDUSTRY TIP

A synchronous motor works with a magnet as the rotor. Electromagnet rotors with a field fed from a DC supply are more widely used than permanent magnet rotors.

leaving no torque to turn the rotor. Single-phase motors need to be modified to give the phase shift needed for the motor to start by itself.

To overcome the starting problem, single-phase motors have some form of additional start winding. The current in this winding can be made to lead or lag the main field winding by various methods. We saw on page 96 that a motor winding is an inductor and resistance. The phase angle can be changed by changing resistance values or by adding a capacitor.

The types of single-phase motors with phase-shift in a start winding are:

- split-phase induction motors
- capacitor-start motors
- shaded-pole motors.

Split-phase induction motors

The split-phase induction motor has a separate start winding connected to the main supply through a centrifugal switch.

ACTIVITY
Can you identify three applications where small synchronous motors would be used in preference to an induction motor?

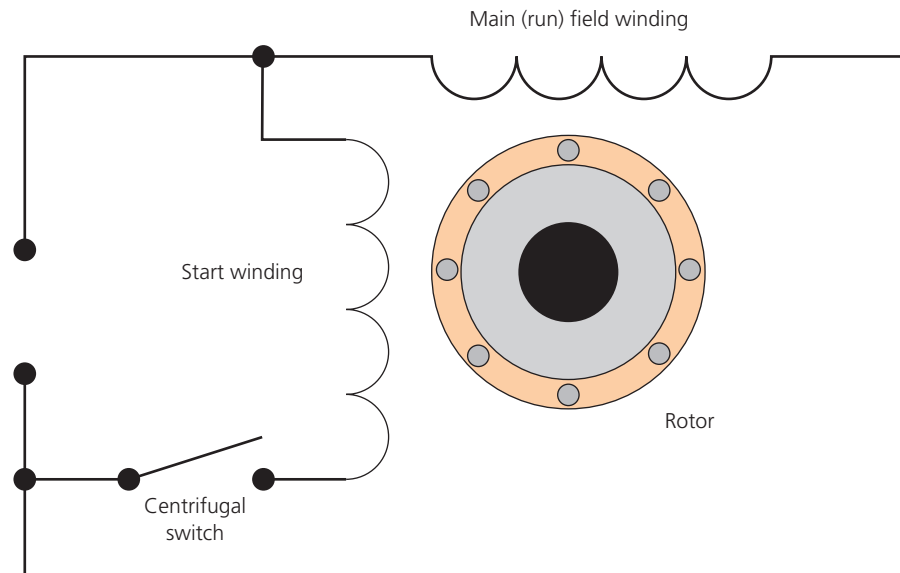

▲ Figure 2.79 Split-phase induction motor

The separate winding causes a slight phase shift by having a different resistance. This causes the rotation. The direction of rotation is determined by the polarity of the start winding, which is switched out by the centrifugal switch once a particular speed is achieved.

Capacitor-start motors

The capacitor-start motor is a variation of the split-phase induction motor. A starting capacitor is in series with the start winding, which creates a phase shift in the circuit due to the inductive and capacitive circuit formed by the winding and the capacitor.

ACTIVITY
Capacitor start-and-run motors have two capacitors. One is electrolytic; the other is a paper type. Why are two types used?

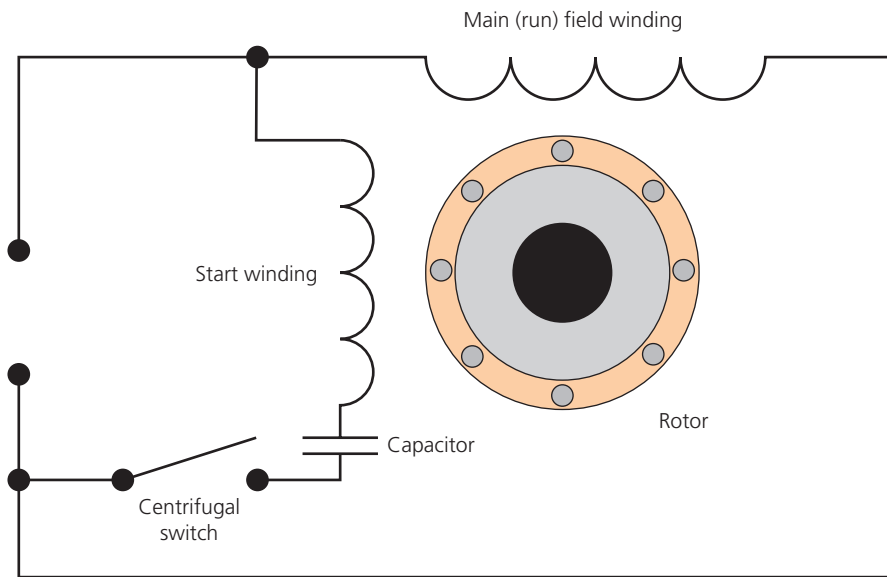

▲ Figure 2.80 Capacitor start motor

In most capacitor-start motors, the capacitor is switched out of circuit by a centrifugal switch. The capacitor-start-and-run motor is a variant that does not switch out the capacitor.

Shaded-pole motors

The shaded-pole motor is quite commonly used in devices, such as domestic appliances, that require low starting torque.

The motor is constructed with small single-turn copper shading coils, which create the moving magnetic field required to start a single-phase motor. A small section of each pole is encircled by a copper coil or strap; the induced current in the strap opposes the change of flux through the coil. This causes a time lag in the flux passing through the shading coil, creating an opposing pole to the main part of the pole. This effect is the same as having a phase shift causing an opposing polarity.

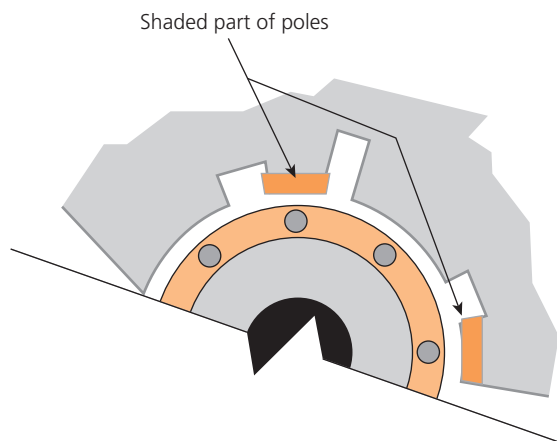

▲ Figure 2.81 Shaded-pole motor

Universal motors

An AC universal motor is very similar in construction to a DC series-wound motor. These devices combine the advantages of AC machines with some of the

INDUSTRY TIP

There are also capacitor-start/capacitor-run motors. These are easily identifiable as they have two external capacitors.

INDUSTRY TIP

AC series universal motors are used in all kinds of domestic appliances, such as vacuum cleaners, spin dryers and lawn mowers although some use induction motors. Drills, saws, angle grinders, etc., all use AC series universal motors.

characteristics of DC. As both field and armature currents reverse at the same time, it will work on an AC supply.

These motors have a high starting torque but, like the DC machine, tend to run very fast on no-load. In most cases a fan is fitted giving air resistance (windage) which limits the speed to a safe value.

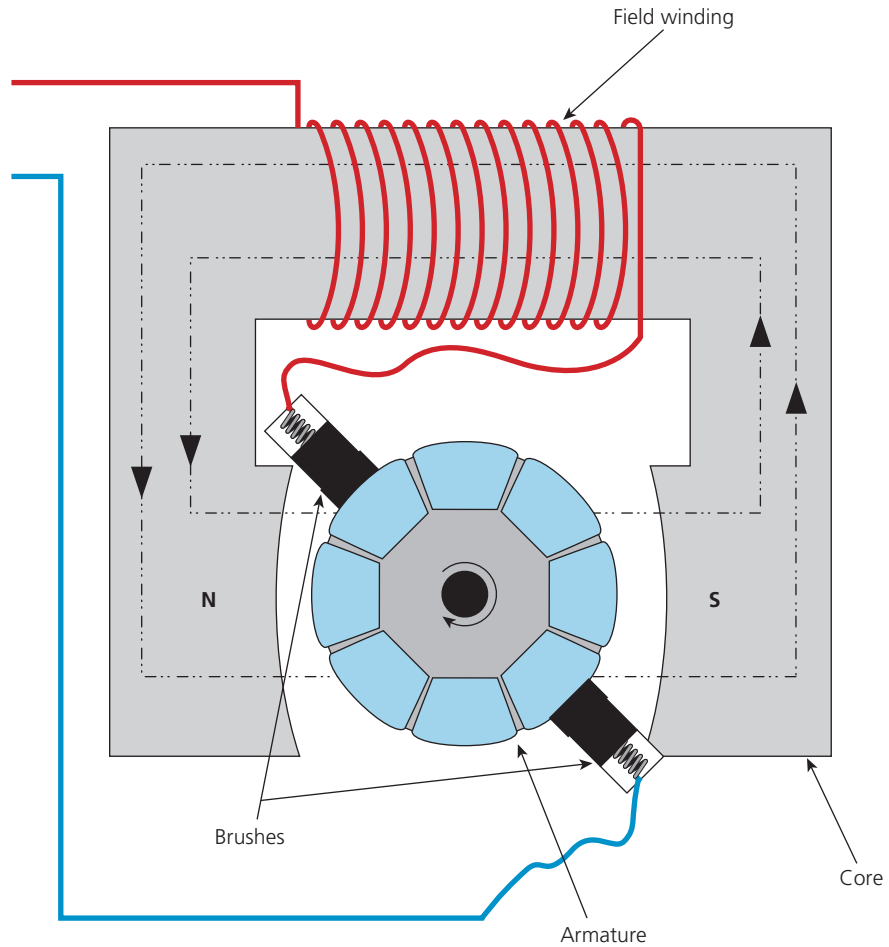

▲ Figure 2.82 Section through a universal motor

Applications of AC motors

Applications of single-phase AC machines

The commonly used shaded-pole motor is used where a high starting torque is not required, for example, in electric fans or drain pumps for washing machines and dishwashers, and in other small household appliances.

Universal motors are commonly used in small household appliances, such as food blenders, or power tools, such as drills, where smaller motors are beneficial.

Capacitor-start motors are commonly found in applications such as central-heating circulation pumps.

Inductive start motors are better suited to belt-drive applications due to poorer starting torque.

Applications of three-phase AC machines

AC generators

The AC generator or alternator is very widely used, e.g. in hybrid electrical vehicle drives, small- and large-scale power generators, wind turbines or micro-hydro systems (small hydro-electric plant using stream water).

Induction motors

The cage induction motor is a simple, cost-effective induction motor. Advances in technologies for drive systems (e.g. thyristor (silicon-controlled rectifier)) and speed-control drives have enabled simple induction motors to replace more expensive wound rotor induction and some DC motors. Such technologies offer simple speed-controlled drives and reduced current starting for 'soft start' systems.

As a result, induction motors are used in a wide range of applications, such as pumps, hoists, lifts and many other machines. The cage rotor is particularly useful because it has fewer parts that are subject to wear, having no brushes or slip rings.

How motor starters operate

Motors are started in various ways. The choice of motor starting/control device depends on:

- available supply (single- or three-phase)
- motor start-up current
- starting speed.

Direct online starters (DOL)

These motor control devices literally switch a motor on or off with no varying speed or reduction in starting current. They are suitable for small, low-powered motors and can be used for single- or three-phase applications. The unit contains an electromagnetic coil that operates a contactor. The unit also incorporates overload contacts, finely tuned to the motor's start and running current to trip the device should an overcurrent occur. The coil that operates the contactor also provides **undervoltage** protection, as the contactor will open should a voltage lower than the coil voltage rating occur, e.g. during loss of supply. This means that the machine will not automatically restart unexpectedly should power resume.

INDUSTRY TIP

When adding remote controls, remember stop buttons are connected in series with the original stop button, and start buttons are connected in parallel with the original start.

INDUSTRY TIP

DOL starters are used with small motors < 5 kW.

KEY TERM

Undervoltage: This could simply be a power cut, or a reduction in voltage stopping equipment functioning. **BS 7671: 2018 (2022)** requires undervoltage protection on any machine where the sudden re-starting of the machine may cause a danger. Using motor controls that require somebody to manually switch the machine back on after a power cut provides undervoltage protection.

INDUSTRY TIP
 Star-delta starters are commonly used on motors, usually rated between 5 kW to 20 kW.

ACTIVITY
 What fraction of power is available in a star connection compared with a delta connection?

INDUSTRY TIP
 Star-delta starting requires access to all six ends of the motor windings.

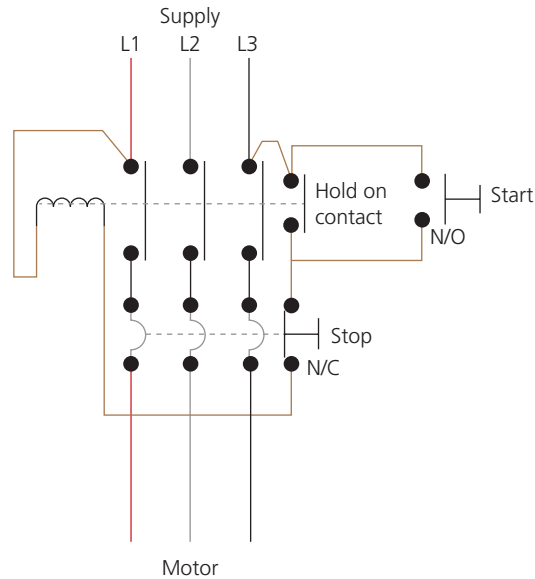

▲ Figure 2.83 Direct online (DOL) starter

Star-delta starters

Star-delta starters must be connected to three-phase motors, which have six connection points at the motor. The motor is started by being put into a star connection, which reduces the starting current. Following a user-set time, which allows the motor to reach a particular speed, a time switch switches over the contactors automatically, putting the motor into delta connection and allowing full load current. The purpose of this is to reduce high current on start-up.

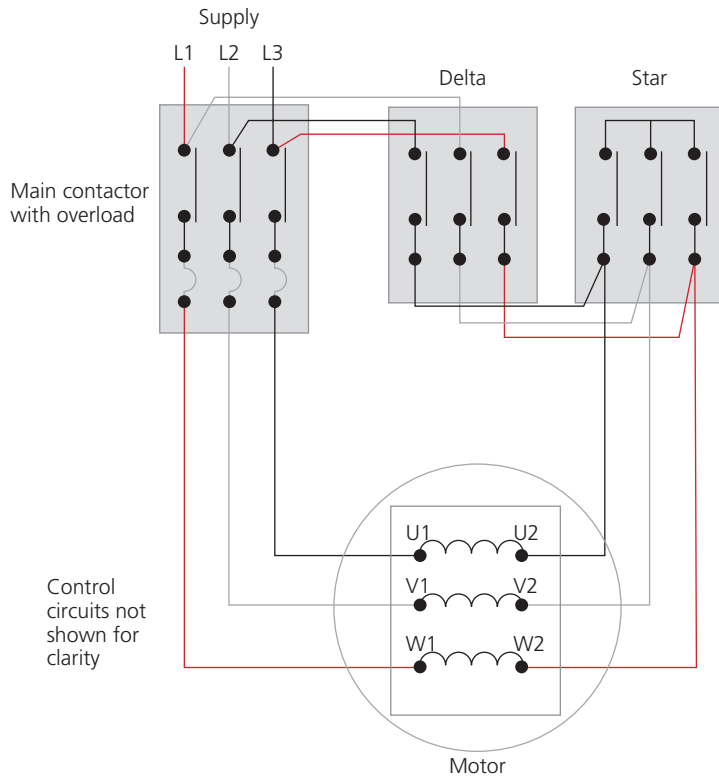

▲ Figure 2.84 Star-delta starter arrangement

To avoid short circuits, the star and delta contactors are normally physically interlocked by an electrical interlock and a mechanical connecting rod to prevent both contactors being in circuit at the same time.

Rotor resistance starters

This type of starting device works by introducing variable resistance to the rotor windings. It requires the motor to be a wound rotor induction motor, not a cage induction motor. The rotor windings are connected to an external variable resistance unit by slip rings and brushes. Variations in resistance can reduce start-up currents in the rotor.

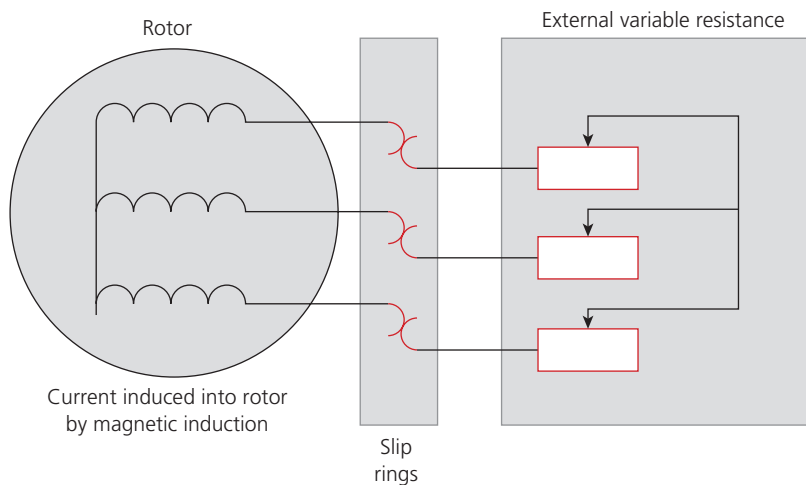

▲ Figure 2.85 Rotor resistance control circuit (stator field winding and supply circuits are not shown for clarity)

Electronic motor starters

These motor soft-starters are used with AC motors to reduce the load and torque in the motor circuit during start-up. This is normally achieved by reducing the voltage; then, as the motor starts to achieve running speed, the voltage is ramped up. The term 'soft-start' applies to the mechanical stresses placed on the components as well, as they are also not subjected to intense starting forces.

Variable frequency drives (VFD) control the motor speed and torque of AC induction motors, by adjusting the frequency and voltage. They save energy and money by adjusting constant-speed devices, such as pumps and fans, to match the appropriate outputs.

Operating principles of motor control

Some motors use reverse-current braking and, where such reversal might result in danger, measures should be taken to prevent continued reversal after the driven parts come to a standstill at the end of the braking period. Further, where safety is dependent on the motor operating in the correct direction, means should be provided to prevent reverse operation. Where motor control systems incorporate overload devices, these devices should be checked to ensure the settings are correct and re-sets are correctly set to manual or automatic.

INDUSTRY TIP

Rotor resistance starters are used when up against heavy loads.

OPERATING PRINCIPLES OF DIFFERENT ELECTRICAL COMPONENTS

In this section you will find out about many types of electrical equipment in everyday use and how they work.

Electricity is an everyday commodity to which most users give little thought. The range and usage of electricity grows every day. New products continue to enter the market and are added to the wide range of electrically powered equipment that people use in everyday life and very quickly take for granted.

Solenoids

The strength of a magnetic field is proportional to the current flowing through it. Even with a high current passing through a conductor, the field produced is relatively weak, in terms of useful magnetism. To obtain a stronger magnetic field, a number of conductors can be added by turning or winding the cable.

The most common form of this arrangement is the solenoid, which consists of one long insulated conductor wound to form a coil. The winding of the coil causes the magnetic fields to merge into a stronger field similar to that of a permanent bar magnet. The strength of the field depends on the current and the number of turns.

Placing a hinged, ferrous material attached to a spring in proximity to the magnetic field will cause that material to be drawn into the field when a very small current is applied to the solenoid.

This mechanical movement can be put to all sorts of uses, including:

- alarm or door bells
- relays
- contactors
- door hold/release systems
- fan shutter open/close drives
- circuit breakers
- residual current devices (RCD).

Some of these applications are described here.

Relays

A relay is an electrically operated switch, which uses an electromagnet to operate a set of contacts mechanically. This mechanical movement allows complete isolation of the switching from the initial signalling.

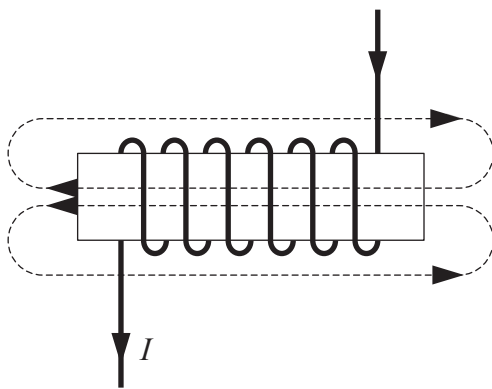

▲ Figure 2.86 A cable wound around a tube: the current at the top moves away from the viewer and the current at the bottom moves towards the viewer

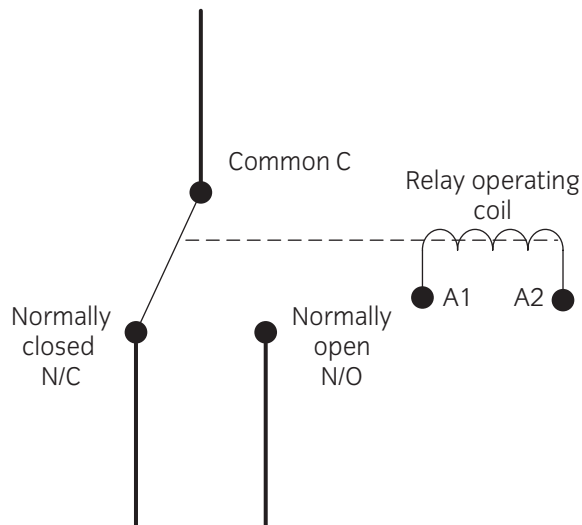

▲ Figure 2.87 Relay showing contact positions

Relays are used often to control a circuit by a low-power signal in complete isolation from the larger circuit, or multiple circuits, being controlled. The first relays were used in long-distance telegraph circuits, repeating the signal coming in from one circuit and re-transmitting it to another. Relays were then used extensively in telephone exchanges to perform logic functions and operations.

With modern technological advances, not all relays consist of a coil operating a set of magnets. Solid-state relays either replace or are available in conjunction with electromechanical relays. Solid-state relays control electrical circuits despite having no moving parts. Instead, they use a semiconductor device to perform the switching.

Contactors

A relay that can handle the high power used to control directly an electric motor or other loads is called a contactor. There is little difference between a relay and a contactor, but generally contactors are devices that switch heavier loads on and off, whereas relays either switch or divert (like a two-way switch) lower current loads.

Protective devices

Protective devices may be one or a combination of:

- fuses
- circuit breakers (CBs)
- residual current devices (RCDs).

Fuses

Fuses have been a tried and tested method of circuit protection for many years. A fuse is a very basic protection device that melts and breaks the circuit should the current exceed the rating of the fuse. Once the fuse has 'blown' (i.e. the element in the fuse has melted or ruptured), it needs to be replaced.

INDUSTRY TIP

Relays are typically defined as an electromagnetic device which permits a small electrical signal to control a much larger one. Equally, a relay can be defined as a device whereby a single input can control a number of outputs.

INDUSTRY TIP

A typical application of a contactor is to control a large heating load by the use of a thermostat. The thermostat can operate at extra-low voltage but still control a large heating load.

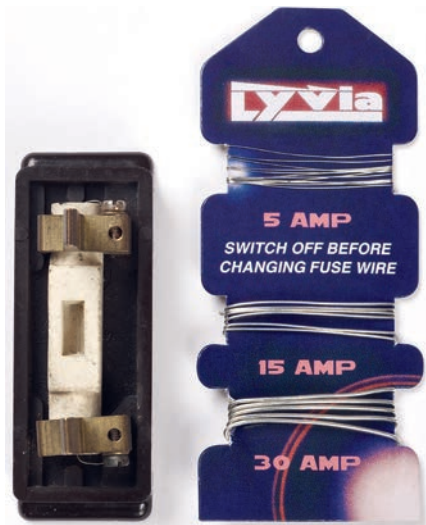

▲ Figure 2.88 Rewirable fuse and fuse wire card showing how wrong wire can easily be used

Fuses have several ratings.

- I_n is the nominal current rating. This is the maximum current that the fuse can carry, without disconnection, and without reducing the expected life of the fuse.
- I_a is the disconnection current rating. This is the value of current that will cause the disconnection of the fuse in a given time, such as 0.4 seconds.
- Breaking capacity (kA) rating. This is the current up to which the fuse can safely disconnect fault currents. Any fault current above this rating may cause the fuse and carrier to explode.

BS 3036 rewirable fuses

In older equipment, the fuse may be just a length of appropriate fuse wire fixed between two terminals. There are increasingly fewer of these devices around as electrical installations are rewired or updated.

One of the main problems associated with rewirable fuses is the overall lack of protection, including insufficient breaking capacity ratings. Another major problem is that the incorrect rating of wire can easily be inserted when replacing the fuse wire, leaving the circuit underprotected.

BS 88 fuses

These fuses are generally incorporated into sealed cylindrical ceramic bodies (or cartridges). If the element inside blows, the whole cartridge needs to be replaced. Although these devices have fixed time current curves, they can be configured to assist selectivity. The benefit of BS 88 and similar fuses is their simplicity and reliability, coupled with high short-circuit breaking capacity.

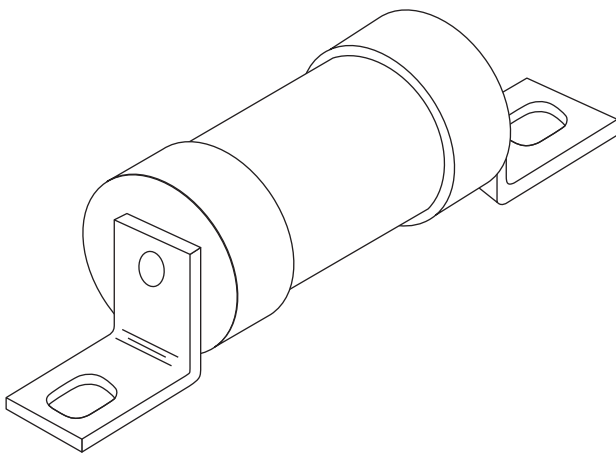

▲ Figure 2.89 BS 88 bolted type fuse

Within some types of BS 88 fuse, usually the bolted type, there may be more than one element. The purpose of this is to minimise the energy from a single explosion, should the fuse be subjected to high fault currents. Instead there will be several smaller explosions, allowing these devices to handle much higher fault current (up to 80 kA).

Other **BS 88** devices may be the clipped type, which do not have the two bolt tags. They are simply barrel shaped and slot into place in the carrier. They are often called cartridge fuses.

Another type of cartridge fuse is the **BS 1362** plug fuse. These are fitted into 13 A plugs and are available in a range of ratings. Typical ratings are 3 A, 5 A and 13 A.

INDUSTRY TIP

The great advantage of circuit breakers is that they do not need replacing in the event of a fault, just resetting.

Circuit breakers

Circuit breakers (CB) have several ratings.

- I_n is the nominal current rating. This is the current that the device can carry, without disconnection and without reducing the expected life of the device.
- I_a is the disconnection current. This is the value of current that will cause the disconnection of the device in a given time.

- I_{cn} is the value of fault current above which there is a danger of the device exploding or, worse, welding the contacts together.
- I_{cs} is the value of fault current that the device can handle and remain serviceable (usable).

Circuit breakers are thermomagnetic devices capable of making, carrying and interrupting currents under normal and abnormal conditions. They fall into two categories: miniature circuit breakers (MCBs), which are common in most installations for the protection of final circuits, and moulded-case circuit breakers (MCCBs), which are normally used for larger distribution circuits.

Both types work on the same principle. They have a magnetic trip and an overload trip, which is usually a bimetallic strip. If a CB is subjected to overload current, the bimetallic strip bends due to the heating effect of the overcurrent. The bent strip eventually trips the switch, although this can take considerable time, depending on the level of overload.

INDUSTRY TIP

BS 7671: 2018 (2022) refers to both miniature circuit breakers (MCB) and moulded-case circuit breakers (MCCB) as circuit breakers (CB).

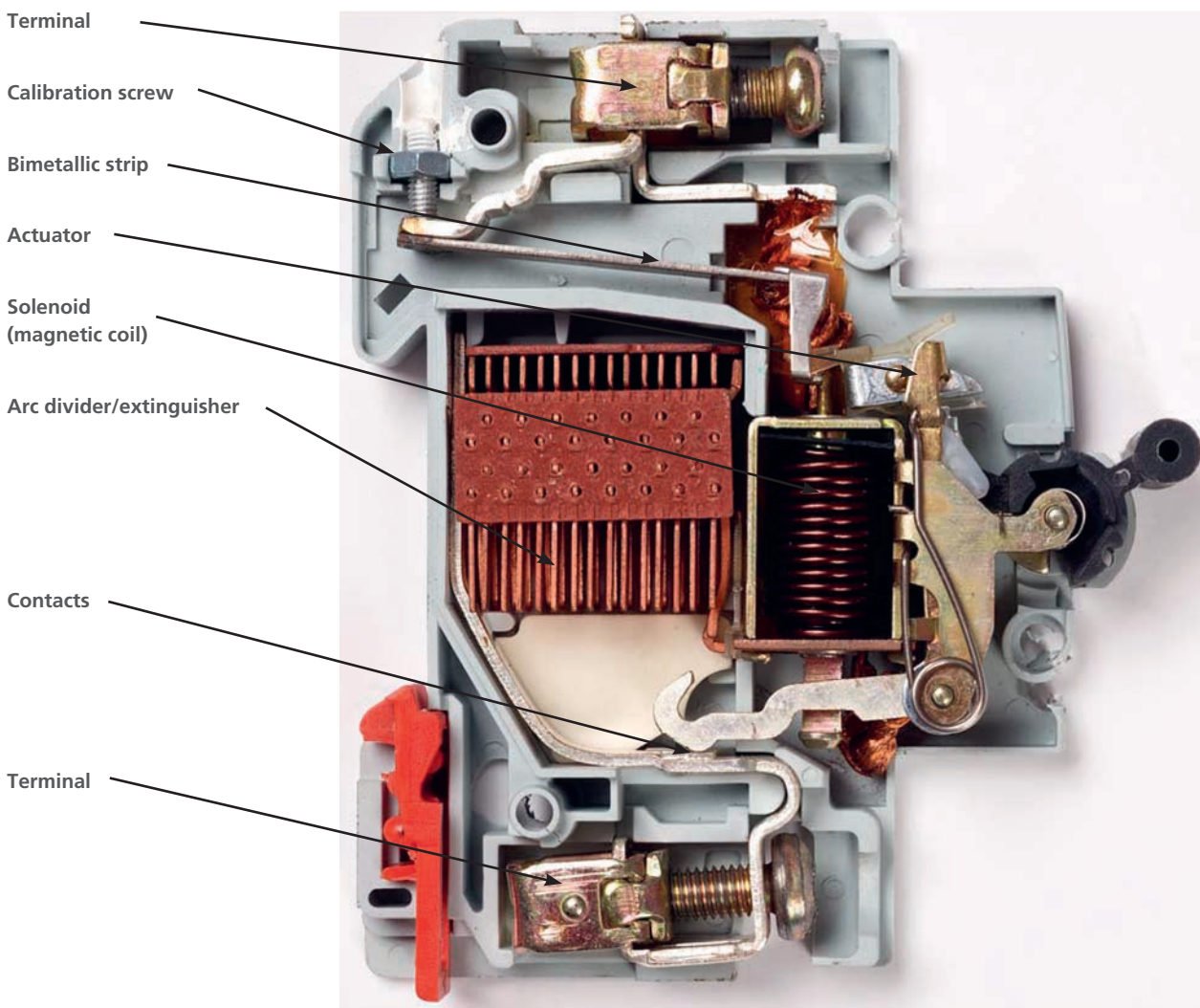

▲ Figure 2.90 Section through a circuit breaker

Miniature circuit breakers (MCBs)

These thermomagnetic devices have different characteristics, depending on their manufacture. They generally have a lower prospective short-circuit current rating than a high-rupturing capacity (HRC) fuse, ranging from approximately 6 kA to 10 kA. Specialist units are available for higher values.

The operating characteristics of MCBs can be shown in graphical form by a time–current curve. MCBs are shown to be generally faster acting than the standard **BS 88** fuses. A CB has a curve, then a straight line, whereas the BS 88 fuse is fully curved. This demonstrates the two tripping mechanisms in a CB. The magnetic trip is represented by the straight line on the graph, indicating that a predetermined value of fault current will disconnect the device rapidly. The curve represents the device’s thermal mechanism. Like a fuse, the thermal mechanism reacts within a time specific to the overload current. The bigger the overload, the faster the reaction.

INDUSTRY TIP

The cost of circuit breakers has come down as their use has become more widespread.

▼ Table 2.2 Rated short-circuit capacity

Device type	Device designation	Rated short-circuit capacity (kA)
Semi-enclosed fuse to BS 3036 with category of duty	S1A S2A S4A	1 2 4
Cartridge fuse to BS 1361 type I type II		16.5 33.0
General purpose fuse to BS 88-2		50 at 415 V
BS 88-3 type I type II		16 31.5
General purpose fuse to BS 88-6		16.5 at 240 V 80 at 415 V
Circuit breakers to BS 3871 (replaced by BS EN 60898)	M1 M1.5 M3 M4.5 M6 M9	1 1.5 3 4.5 6 9
Circuit breakers to BS EN 60898* and RCBOs to BS EN 61009		I_{cn} I_{cs} 1.5 (1.5) 3.0 (3.0) 6 (6.0) 10 (7.5) 15 (7.5) 20 (10.0) 25 (12.5)

* Two short-circuit capacities are defined in **BS EN 60898** and **BS EN 61009**:

- I_{cn} the rated short-circuit capacity (marked on the device).
- I_{cs} the in-service short-circuit capacity.

Source: Rated short-circuit capacities of protective devices: Table 7.2.7(i) (from the On-Site Guide, IET)

Moulded-case circuit breakers (MCCBs)

Although moulded-case circuit breakers (MCCBs) work on the same principle as MCBs, the moulded case construction and physical size of MCCBs gives them much higher breaking capacity ratings than those of MCBs. Many MCCBs have adjustable current settings.

Residual current devices (RCDs) and residual current circuit breakers with overload (RCBOs)

Residual current devices (RCDs) operate by monitoring the current in both the line and neutral conductors of a circuit. If the circuit is healthy with no earth faults, the toroidal core inside the device remains balanced with no magnetic flux flow. If a residual earth fault occurs in the circuit, slightly more current flows in the line conductor compared to the neutral. If this imbalance exceeds the residual current setting of the device, the flux flowing in the core is sensed by the sensing coil, which induces a current to a solenoid, tripping the device.

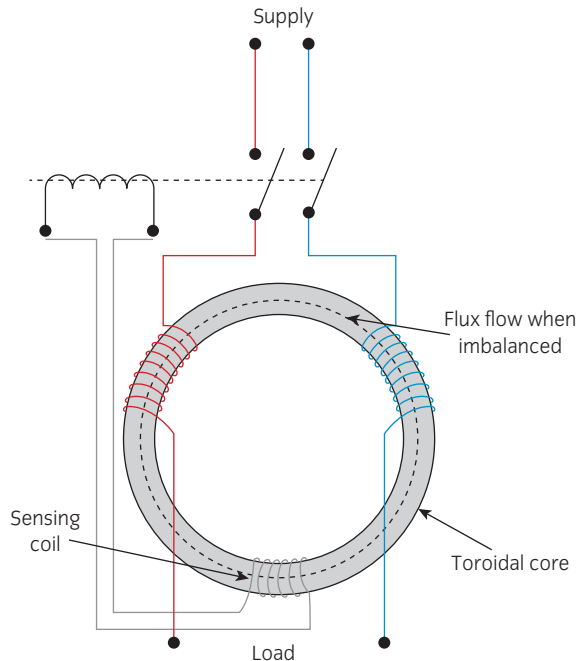

▲ Figure 2.91 Internal circuit diagram for an RCD

Residual current breakers with overload (RCBOs) combine an overcurrent protective device with an RCD in the body of the CB.

Unlike CBs, RCDs and RCBOs have a test button, which should be pressed at very regular intervals to keep the mechanical parts working effectively. If the mechanical components in a CB stick, there is not much concern as the energy needed to trip a CB is large enough to unstick any seized parts. As RCDs and RCBOs operate under earth fault conditions, with relatively small residual currents, there may not be enough energy to free any seized parts.

ACTIVITY

What rating of RCD would be used to provide additional protection?

HEALTH AND SAFETY

Remember that RCDs only offer earth fault protection not short-circuit (line to neutral) or overload protection. If an RCD is fitted to a circuit, appropriate protective devices must also be installed to offer short-circuit and overload protection.



▲ Figure 2.92 RCBO to BS EN 61009

APPLICATION OF ELECTRICAL COMPONENTS IN ELECTRICAL SYSTEMS

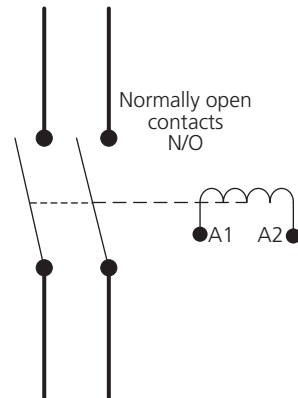

▲ Figure 2.93 Typical contactor

Solenoids

Solenoids have a number of functions. They are often used as electrical–mechanical transducers (converters), i.e. they convert an electrical signal into mechanical action. This can be as some form of limit switch that trips a non-automatically resettable device or, more commonly, to operate a control valve on heating and other similar systems.

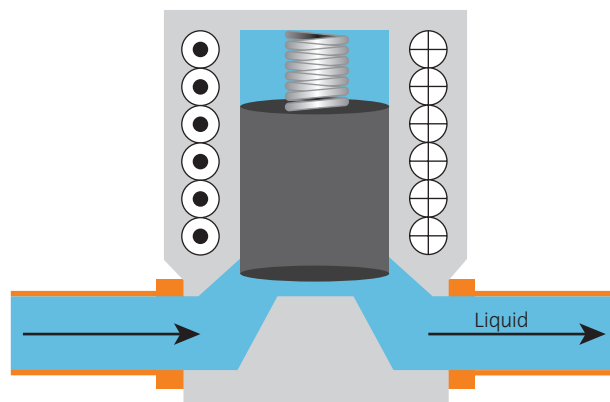

▲ Figure 2.94 Solenoid valve

Solenoids are also often used in electromagnetic locking devices, either to engage or to retract the locking mechanism. Where safety is essential, such solenoids are usually positioned so that the system drops to a safe position if the electrical circuit fails. For example, a door release magnet will release the door in the event of a fire.

Relays

A relay is used so that one circuit, normally a low-current circuit, controls another by use of remote contacts. Some relays operate a large number of contacts, switching multiple circuits, with complete electrical isolation of the switching circuit from the operating circuit. Others switch high-current circuits using either

low-power circuits or even extra low-voltage circuits, which are in turn controlled by logic devices such as programmable logic controllers (PLCs).

Contactors

The term 'contactor' is often used instead of 'relay'; however, 'contactor' is more accurately used for a large relay operating large loads, such as a motor.

In the case of motor starters such as the direct online (DOL) starter (see page 123), the contactor is also coupled to an overload device. The contactor itself provides control (on and off) as well as undervoltage protection, which is required where the loss of supply and subsequent restoration may cause danger. In the case of a motor or machine, the machine cannot restart after a loss of supply until someone physically pushes the start button on the starter.

ACTIVITY

A direct online motor starter is a type of contactor with built-in start and stop controls. It also has overload protection. Name two types of overload protection that are used.

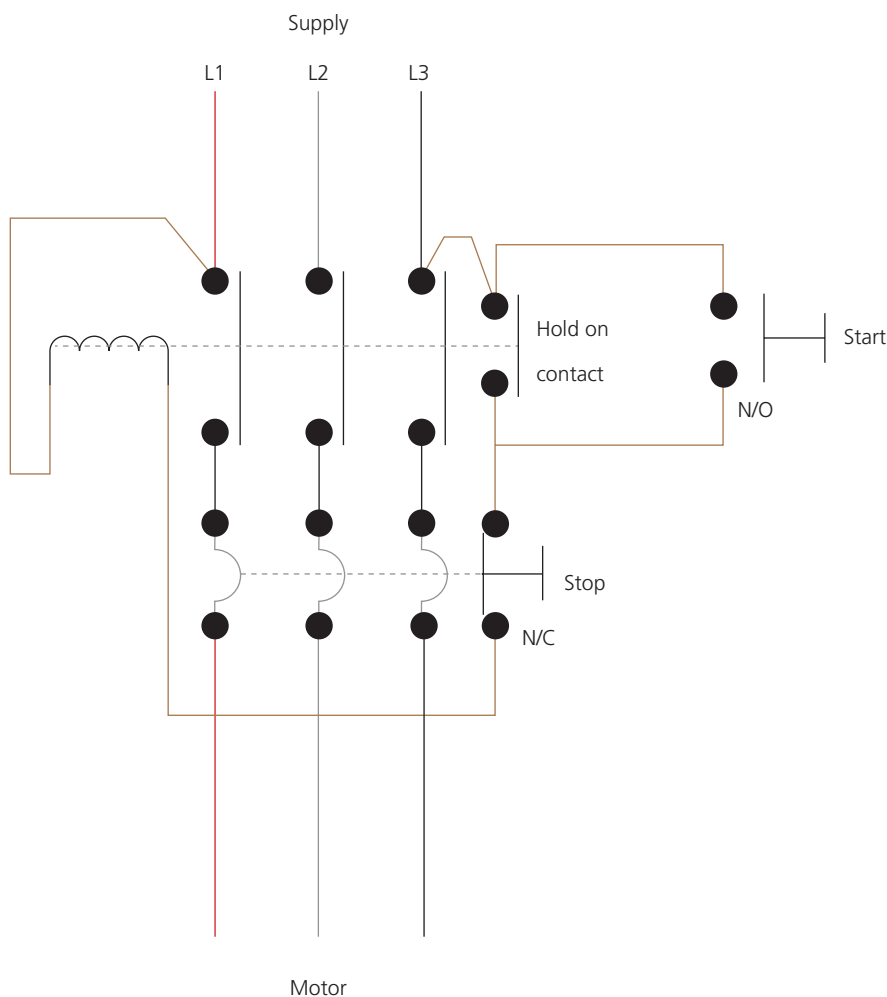

▲ Figure 2.95 A typical example of a contactor: direct online (DOL) starter arrangement

BS 3036 rewirable fuses

Unlike most other protective devices, the BS 3036 fuse arrangement does not have a very accurate operating time or current as it is dependent upon factors such as age, level of oxidation on the element and how it has been installed (e.g. whether it was badly tightened, open to air movement).

ACTIVITY

Identify two other rewirable fuse carrier ratings and colours.



▲ Figure 2.96 A range of BS 3036 rewirable fuses: 5 A (white), 15 A (blue) and 30 A (red)

The lack of reliability of these fuses is a concern to designers and duty holders. Due to the lack of sensitivity, special factors have been applied to Appendix 4 of **BS 7671: 2018 (2022)** The IET Wiring Regulations, 18th Edition to account for these fuses. This rating factor to be applied (C_f) is 0.725.

BS 88 fuses

High-rupturing capacity (HRC) or high-breaking capacity (HBC) fuses are common in many industrial installations. They are also very common in switch fuses or fused switches controlling specific items of equipment. They are particularly suited to installations with a high prospective fault current (I_{pf}) as they have breaking capacities of up to 80 kA.

BS 88 fuses come in two categories:

- gG for general circuit applications, where high inrush currents are not expected
- gM for motor-rated circuits or similar, where high inrush currents are expected.

Miniature circuit breakers (MCBs)

There are three common types of MCB: Type B, Type C and Type D. The difference between the devices is the value of current (I_a) at which the magnetic part of the device trips. The different types are selected to suit loads where particular inrush currents are expected.

Type B trips between three and five times the rated current (3 to $5 \times I_n$). These MCBs are normally used for domestic circuits and commercial applications where there is no inrush current to cause it to trip. For example, the magnetic tripping current in a 32 A Type B CB could be 160 A. So $I_a = 5 \times I_n$. These MCBs are used where maximum protection is required and therefore should be the choice for general socket-outlet applications.

INDUSTRY TIP

In a fused switch the fuses are mounted on the moving contacts. In a switch fuse, the fuse and switch are in series and the fuse does not move.

Type C trips between five and ten times the rated current (5 to $10 \times I_n$). These MCBs are normally used for commercial applications where there are small to medium motors or fluorescent luminaires and where there is some inrush current that would cause the CB to trip. For example, the magnetic tripping current in a 32 A Type C CB could be 320 A. So $I_a = 10 \times I_n$.

Type D trips between ten and twenty times the rated current (10 to $20 \times I_n$). These MCBs are for specific industrial applications where there are large inrushes of current for industrial motors, X-ray units, welding equipment, etc. For example, the magnetic trip in a 32 A Type D CB could be 640 A. So $I_a = 20 \times I_n$.

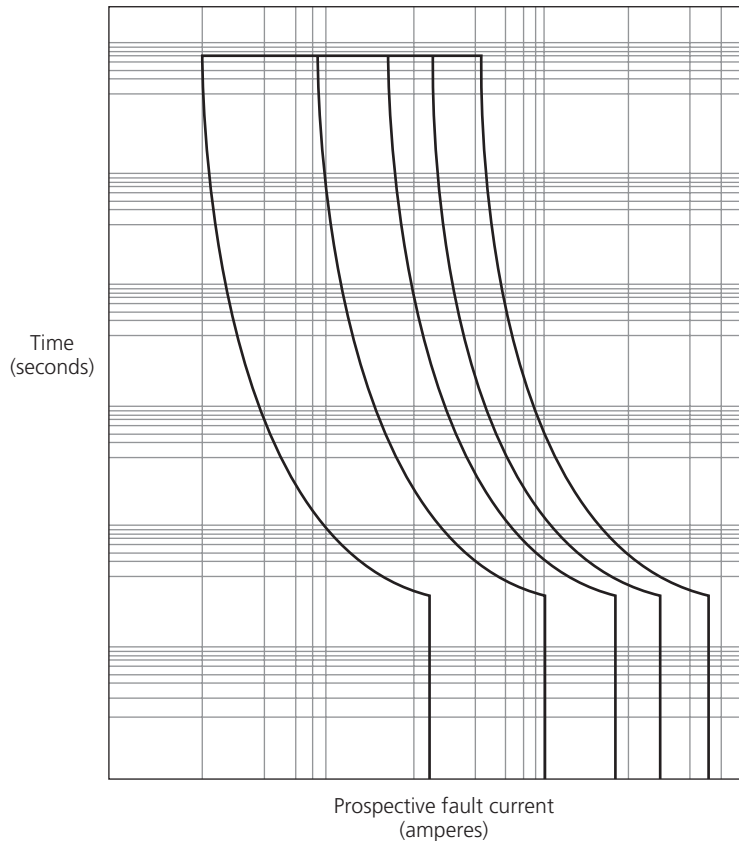

▲ Figure 2.97 Sample time–current characteristic graph which is found in Appendix 3 of BS 7671: 2018 (2022)

Moulded-case circuit breakers (MCCBs)

MCCBs are available in various ranges. Lower-cost simpler versions are thermomagnetic with no adjustment. Other devices have electronic trip units and sensitivity settings or the ability to be de-rated.

Most MCCBs are used on larger circuits or distribution circuits where larger prospective short circuits are likely but the flexibility of an electronic trip is also required.

Residual current devices (RCDs) and residual current circuit breakers with overload (RCBOs)

RCDs are sensitive devices, typically operating on earth fault currents as low as 30 mA and with response times as fast as 20–40 ms.

The use of such a device is useful for supplies to portable electrical equipment where the risk of shock to the user might be higher than would otherwise be the case. **BS 7671: 2018 (2022)** provides for wider use of RCDs, both for indoor circuits as well as for socket outlets intended to supply portable electrical equipment outdoors, i.e. outside the zone of earthed equipotential bonding.

Arc Fault Detection Devices (AFDD)

Arc fault detection devices were introduced into BS 7671 in 2015 as recommended devices for certain electrical installations such as those containing sleeping accommodation.

BS 7671: 2018 (2022) has now made it a requirement to install AFDDs at the origin of all circuits supplying socket outlets with a current rating not exceeding 32 A in:

- high-risk residential buildings (high-rise residential properties over 18 m in height or having 6 storeys or more)
- houses of multiple occupation (HMOs)
- purpose build student accommodation
- care homes.

AFDDs are recommended for the protection of socket-outlet circuits in all other premises.

AFDDs can be either standalone devices or incorporated within protective devices such as circuit breakers or RCBOs.

They use microprocessors to monitor for a signature waveform created by an arc. They can monitor both series and parallel arcs (see Figure 2.98) both in a circuit or any appliance connected to a circuit.

▼ Figure 2.98 Series and parallel arcs in a circuit

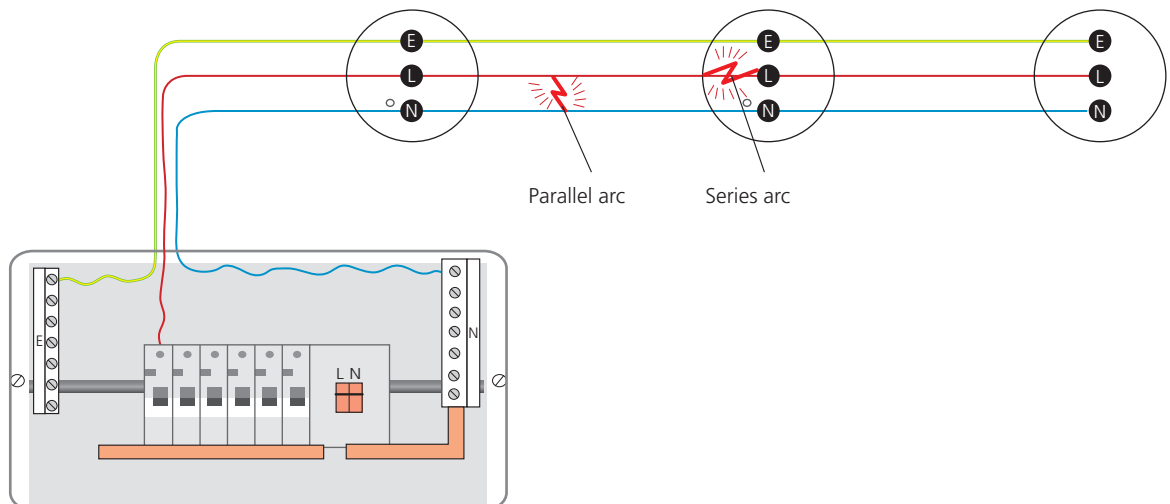

Series arcs are commonly caused by loose connections and parallel arcs can be caused by insulation breaking down or something, for example liquids, contaminating terminals.

ELECTRICAL LIGHTING SYSTEMS

Lighting is a specialist area in electrical installations work. Many designers and installers rely on specialists to manage the design of lighting, but there are some basic areas of knowledge that an electrician needs to know in order to install and maintain luminaires effectively.

Laws of illumination and illumination quantities

Two laws explain how light behaves when it is emitted from a luminaire onto a surface: the inverse square law and the cosine law. First, look at the terms and units used to explain and quantify lighting.

▼ Table 2.3 Lighting terms and units

Term	Symbol	Unit	Description
Luminous intensity	<i>I</i>	candela (cd)	The amount of light emitted per solid angle or in a given direction
Luminous flux	<i>F</i>	lumen (lm)	The total amount of light emitted from a source
Illuminance	<i>E</i>	lumens per metre ² (lux)	The amount of light falling on a surface
Efficacy	<i>K</i>	lumens per watt (lm/W)	This is a term used to measure the efficiency of a lamp or luminaire. It compares the amount of light emitted to the electrical power consumed.
Maintenance factor Or Light loss factor	Mf llf	none	These factors are used to de-rate the light output of a lamp, allowing for dust. The factor used depends on the environment. An average office environment would have a factor of 0.8 whereas a factory where lots of dust accumulates may be 0.4.
Coefficient of utilisation or utilisation factor	Uf	none	This factor takes the surfaces in a room, such as walls and ceilings, into account. Emitted light bounces off walls that reflect light well, making more effective use of the light. An average factor for a room is 0.6. The lighter the colour of the room, the higher the factor.
Space–height ratio			This ratio is used to determine how close together luminaires need to be, taking into account their height from a given surface, in order to illuminate a room with an even spread of light from multiple luminaires.

KEY TERMS

Efficiency: the ratio between power in and power out, measured in the same unit.

Efficacy: the ratio of power in and power out, measured in two different units. For example, the ratio of light output in lumens to the electrical power measured in watts.

Some lamps, such as light-emitting diode (LED) lamps, are rated in lumens whereas others are rated in candela. Take care with this as the choice of lamp depends on its application. To illuminate a particular point, such as a kitchen work surface, the candela rating is important as it rates the intensity of light in a particular direction. For illuminating a general area, such as a driveway, the luminous flux (lumens) is a better indicator as it measures the total light output in all directions.

ACTIVITY



A luminaire emits 1250 candela in all directions. Calculate the illuminance at a) 2.5 m and b) 5 m directly below the luminaire.

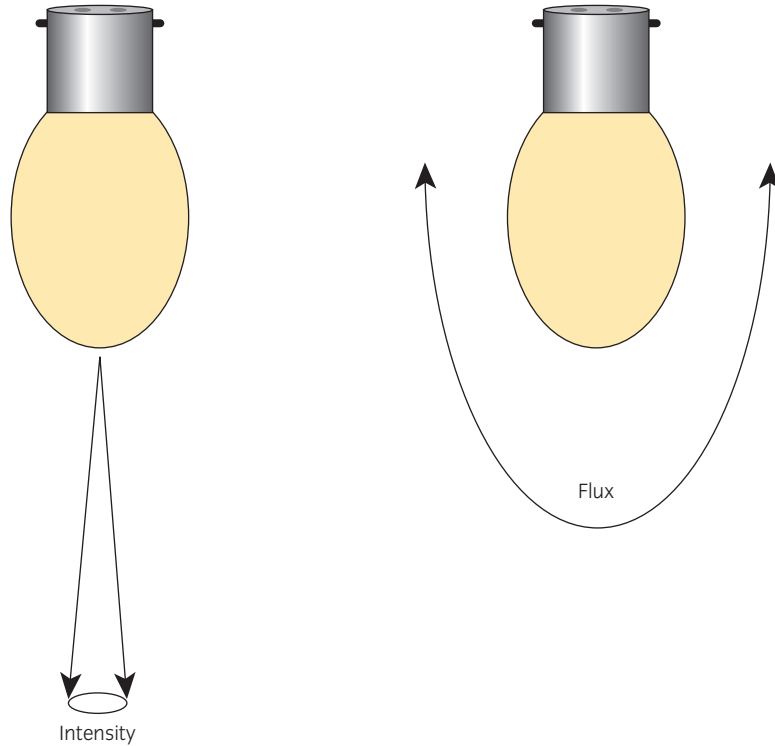

▲ Figure 2.99 Candela is the rating of intensity. The rating of total light output in all directions is the lumen.

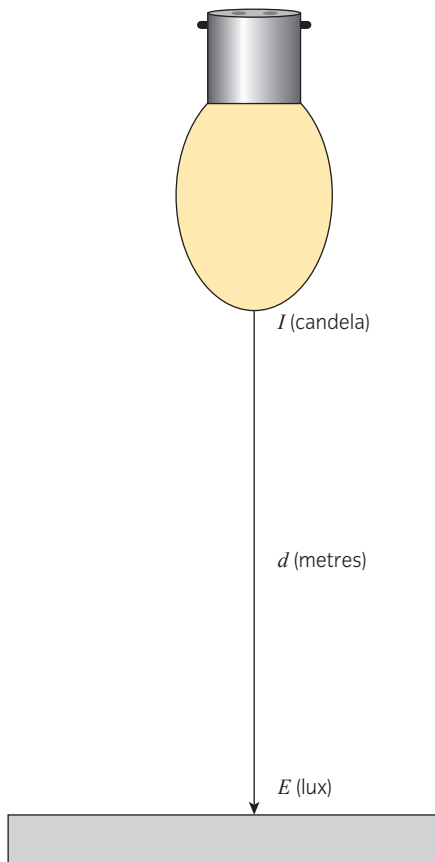

▲ Figure 2.100 The inverse square law is used to determine the illuminance (lux) of a surface

Inverse square law

The amount of light falling onto a surface changes depending on the distance from the light source. If you hold a torch just above a surface, the light falling on the surface is intense. As you move the torch further away, the light directly below the torch becomes less intense because the light spreads. The amount of light on the surface is the illuminance. To determine the amount of light on the surface directly below the source, use the inverse square law.

$$E = \frac{I}{d^2} (\text{lux})$$

where:

I = luminous intensity, in candela (cd)

E = illuminance on the surface, in lux

d = distance between the lamp and surface, in metres (m).

EXAMPLE

A 1000 cd light source is suspended above a level plane. Calculate the illuminance of the surface at 2 m and 4 m from the source.

At 2 m:

$$E = \frac{I}{d^2}$$

Therefore:

$$E = \frac{1000}{2^2} = 250 \text{ lux}$$

At 4 m:

$$E = \frac{I}{d^2}$$

Therefore:

$$E = \frac{1000}{4^2} = 62.5 \text{ lux}$$

**IMPROVE YOUR MATHS**

The inverse square law and cosine law are basically the same. It is just that the cosine of 0° is 1, so it has no effect on the calculation.

Cosine law of illumination

When light falls obliquely on a surface, not at right angles to it, the light spreads over an increasing area as the angle (θ) between the perpendicular to the surface and the direction of the light increases.

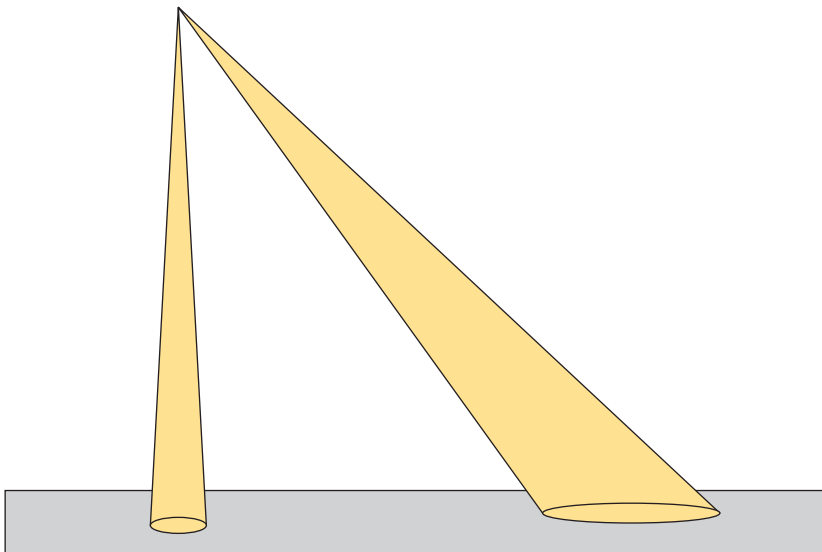

▲ Figure 2.101 The spread of light at different angles

To calculate illumination in such cases, use the cosine law, which takes the additional area illuminated into account. It is expressed as:

$$E = \frac{I}{h^2} \times \cos \theta \text{ (lux)}$$

where:

I = luminous intensity, in candela (cd)

E = illuminance on the surface, in lux

d = distance between the lamp and surface, in metres (m)

h = distance between the lamp and the surface to be illuminated

$\cos \theta$ = cosine of the angle at which the light is emitted from the lamp.

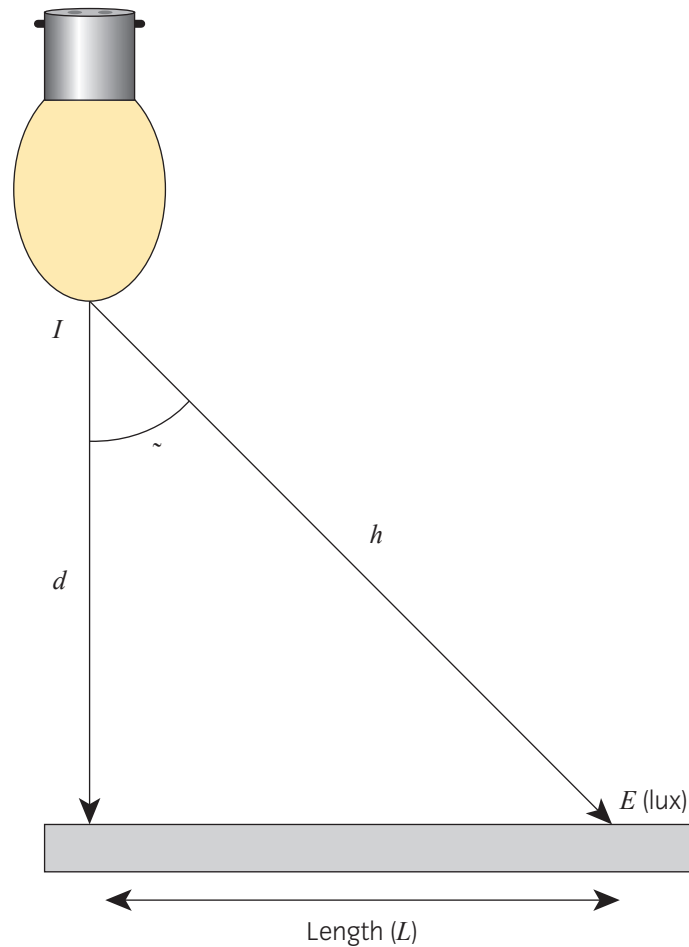

▲ Figure 2.102 Calculating illumination at different angles

If the angle is unknown, the cosine of the angle can be determined by using Pythagoras' theorem and trigonometry.

As:

$$h = \sqrt{d^2 + L^2}$$

and:

$$\cos \theta = \frac{d}{h}$$

EXAMPLE

A 1200 cd light source is suspended above a level plane. Calculate the illuminance of the surface at 2 m directly below the source (E_1) and then calculate the illuminance on a surface 4 m away (E_2).

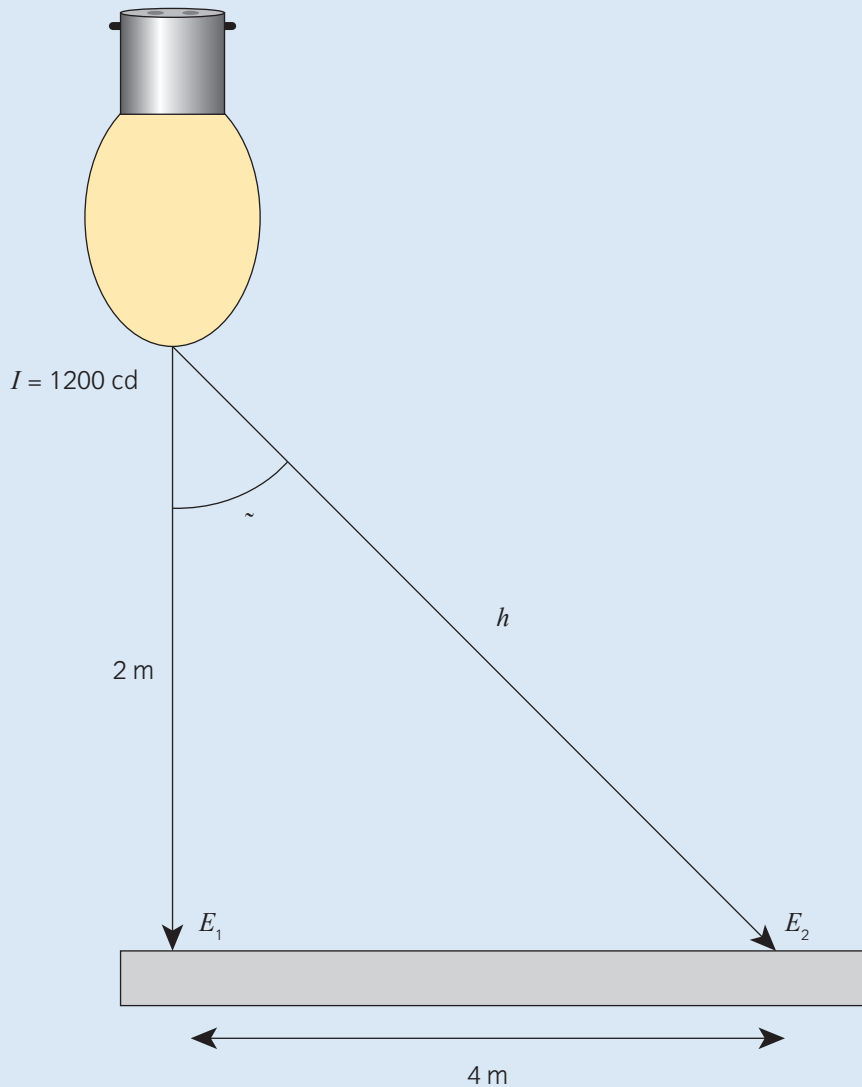

▲ Figure 2.103 Calculating illuminance directly below the source and 4 m away

$$E_1 = \frac{I}{d^2}$$

Therefore:

$$E_1 = \frac{1200}{2^2} = 300 \text{ lux}$$

To determine E_2 , find $\cos \theta$.

So:

$$h = \sqrt{d^2 + L^2}$$

Therefore:

$$h = \sqrt{2^2 + 4^2} = 4.47 \text{ m}$$

and

$$\cos \theta = \frac{d}{h}$$

Therefore:

$$\frac{2}{4.47} = 0.45$$

Therefore:

$$E_2 = \frac{1200}{4.47^2} \times 0.45 = 27.0 \text{ lux}$$

Lumen method

As can be seen from the cosine law, the level of light varies across an area due to the distance and angle of the light source. When a desired level of illuminance is specified, an average figure is used across the area or working surface.

Lighting guides give values of illuminance that are suitable for use in various areas. The average value is usually quoted in lux.

The lumen method is used to determine the number of lamps that should be installed for a given area or room to achieve a specific average illuminance level.

INDUSTRY TIP

You can research recommended illuminance levels by visiting the HSE or CIBSE websites.

▼ Table 2.4 Guided average illuminance levels for different activities or areas

Activity or area	Illumination (lux, lumen/m ²)
Public areas with dark surroundings	20–50
Working areas where visual tasks are only occasionally performed	100–150
Warehouses, homes, theatres, archives	150
Classrooms	250–350
Normal office work, computer work, study library	350–450
Supermarkets, mechanical workshops	750
Normal drawing work, detailed mechanical workshops	1000
Detailed drawing work, very detailed mechanical works	1500–2000
Performance of very prolonged and exacting visual tasks	5000–10 000

Figures are estimated based on various information sources

Calculating for the lumen method

The lumen method is appropriate for use in lighting design if the luminaires are to be mounted overhead in a regular pattern.

The luminous flux output (lumens) of each lamp needs to be known, as well as details of the luminaires and the room surfaces.

Usually, the illuminance will already have been specified by the designer, e.g. office 350–450 lux.

The formula is:

$$N = \frac{E_{\text{average}} \times A}{Mf \times Uf \times F}$$

where:

E_{average} = average illuminance over the horizontal working plane, in lux

N = number of luminaires required

F = luminous flux of each luminaire selected, in lumens (as declared by the manufacturer)

Uf = utilisation factor based on the reflectance of the room walls, ceiling and work surface

Mf = maintenance or light loss factor (llf)

A = area to be illuminated.

INDUSTRY TIP

The maintenance or light loss factor is composed of three items: dirt on the walls and in the air, dirt on the fittings and aging of the lamps.

EXAMPLE

Determine the number of luminaires required in an office measuring 18 m by 20 m. The room is to be illuminated using recessed modular luminaires with a luminous flux given as 4800 lumens per fitting. The room has a white ceiling and walls painted a light colour; as a result, the utilisation factor is 0.9. As dust in an office is minimal, the maintenance factor is 0.8. The average illuminance desired is 400 lux.

Using:

$$N = \frac{E_{\text{average}} \times \text{area}}{Mf \times Uf \times F}$$

$$N = \frac{400 \times (18 \times 20)}{0.8 \times 0.9 \times 4800} = 41.67 \text{ or } 42 \text{ luminaires}$$

ACTIVITY

Determine the number of luminaires needed to illuminate your classroom to an average illuminance of 350 lux. Determine the utilisation factor and maintenance factor, based on the brightness and dust accumulation of the room. Use manufacturer's data to obtain the luminous flux of a luminaire.

Operation and application of luminaires

Space–height ratio

The space–height ratio determines how far apart luminaires should be in relation to their intended mounting height, or vice versa. The ratio depends on the particular luminaire and is determined by the manufacturer.

INDUSTRY TIP

The actual number of fittings installed may be slightly higher than the calculated number to give equal numbers in each row.

EXAMPLE

If the space–height ratio of a luminaire is 3:2 and the mounting height is 2.4 m above the working plane (the area where the maximum illuminance is needed), determine the distance needed between luminaires.

$$\frac{S_r}{H_r} = \frac{S}{H}$$

where:

S_r is the space ratio

H_r is the height ratio

S is the actual spacing between luminaires (centre to centre)

H is the height the luminaires are mounted.

$$\frac{3}{2} = \frac{S}{2.4}$$

So:

$$\frac{3 \times 2.4}{2} = S = 3.6 \text{ m}$$

Efficacy

Lamps are given an efficacy rating based on the amount of luminous flux (in lumens) emitted by the lamp for every watt of power consumed by the lamp, including losses (in watts). An efficacy rating is a good indication of a particular lamp's energy efficiency. The higher the efficacy rating, the better the energy efficiency.

$$\text{efficacy} \frac{\text{lm}}{\text{W}} = \frac{\text{light output (lm)}}{\text{electrical input (W)}} \quad \text{lm/W}$$

ACTIVITY

Using the internet, look up the current requirements for lighting efficacy according to the Code for Sustainable Homes.

The purpose of a lamp is to produce light. Lamps also produce heat during operation. As energy is required to produce the heat, this counts as a loss of energy because heat is not the intended product of the lamp.

In order for buildings to comply with current Building Regulations or the Code for Sustainable Homes, guidelines are given for the minimum lumens of light per circuit watt consumed.

EXAMPLE

The light output from a lamp is 8000 lumens and the input power is 150 watts. Calculate the efficacy of the lamp.

$$\text{efficacy} \frac{\text{lm}}{\text{W}} = \frac{8000}{150} = 53.33 \text{ lm/W}$$

▼ Table 2.5 Indication of the efficacy of different lamp types. Consult manufacturer's data for accurate ratings for particular lamps.

Lamp type	Efficacy (lm/W)
60 W GLS incandescent lamp	14
100 W tungsten halogen	16
50 W high-pressure sodium (SON)	120
18 W compact fluorescent (CF)	61
70 W metal halide	64
20 W T5 fluorescent tube	99
2 W LED*	110
90 W low-pressure sodium (SOX)	180

*LED lighting figures are based on recessed down-lighting. Efficacy depends on lamp or luminaire design.

Colour rendering

The term 'colour rendering' describes the ability of a lamp or luminaire to keep objects looking their true colour. Some lamps emit orange light and so objects lit by the lamp appear orange.

Colour rendering is very important when selecting luminaires, depending on their application. For example, general amenity lighting or street lighting does not require good colour rendering unless closed circuit TV (CCTV) is present, in which case this factor is important. Studies have shown that better colour rendering of street lighting in some areas can reduce crime, as criminals are aware that they can be identified more easily.

Colour rendering is also important in shops. Installing the correct type of lamp can make clothes look vibrant, food look appetising and also reduce eye strain. There are many types of fluorescent or LED replacement tube colours available, from warm white to daylight and colouright tubes, which give accurate colour rendering.

More information relating to the application of different types of luminaires and lamps is given below.

Operation of lamps

There are several types of lamp, each of which works in different ways:

- incandescent lamps
- discharge lamps
- compact fluorescent lamps
- LED lamps.

INDUSTRY TIP

Just because a lamp has a good efficacy rating does not necessarily mean it is suitable. For example, the SOX lamp has extremely good efficacy but very poor colour rendering as everything illuminated by it looks orange!

INDUSTRY TIP

General lighting service (GLS) lamps have largely been replaced by compact fluorescent lamps or LED lamps, due to the low efficacy of the GLS types.

Incandescent lamps

This is the simplest form of lamp, with a current passed through a filament. The filament gets white hot and therefore emits light.

Tungsten filament lamps

Tungsten has a high melting temperature (3380 °C) and the ability to be drawn out into a fine wire.

In order to prevent premature failure through oxidation, oxygen must be removed from the enclosing glass bulb. Small lamps are evacuated, creating a vacuum in the bulb, but larger lamps are filled with argon, which reduces filament evaporation at high temperatures. The efficacy of filament lamps is relatively low but increases with the larger sizes. Colour rendering is generally very good but does depend on the glass finish of the lamp.

Tungsten-halogen lamps

Adding a halogen, such as iodine, to the enclosure prevents evaporation and allows the lamp to be run at a higher temperature. Colour rendering is very good with these lamps.

Halogen cycle

If a halogen gas is present in a lamp with a tungsten filament, the atoms of tungsten that are driven off the filament attach to halogen molecules instead of collecting on the lamp wall. They are eventually returned to the filament and separated. The tungsten is deposited on the filament. The halogen gas molecules are free to circulate again and available to intercept other tungsten atoms.

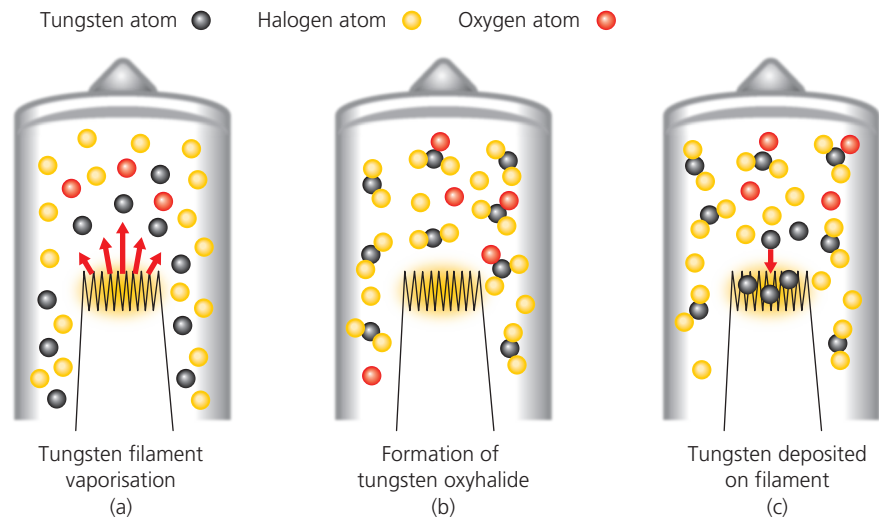

▲ Figure 2.104 Halogen regenerative cycle

Halogens condense at about 300 °C, so the lamp must be kept above this temperature. The lamp is made of quartz glass, which can be weakened if touched by a person. Oil from the skin can lead to gas leaking from the glass. Handling these lamps without protection can therefore shorten their lifespan.

Tungsten-halogen lamps are widely used for floodlighting and vehicle-lighting applications as well as low voltage recessed lighting.

Discharge lamps

The way a heated filament produces light is relatively simple to understand. How light is emitted when an electric current flows in a gas or vapour can be more difficult to understand. Think about how in nature lightning produces large quantities of light when electric current passes through a gas (air).

Several types of lamp produce light by establishing a permanent electric arc in a gas. This process is known as electric discharge or gaseous discharge. It is used to produce light in fluorescent and high-intensity discharge lamps.

How discharge lamps work

Electrons are driven through the gas or vapour by the tube voltage, colliding with atoms as they go. The collisions are severe enough to break a loosely held electron from an atom, leaving behind a positively charged ion. This type of collision needs a fairly high tube voltage and results in ionisation to produce light.

Different gases and pressures of gas produce light of different wavelengths or colours, which can be further enhanced by using a coating such as phosphor around the inside of the gas tube.

When gas is cold, it has a high resistance and therefore requires a high-voltage 'strike' to ionise the gas. Once gas is ionising, its resistance falls, meaning lower voltages can maintain ionisation. However, as proved by Ohm's law, a lower resistance will result in larger currents flowing. In order to create a high-voltage strike and limit running currents, discharge luminaires require control gear.

For AC supplies, an electronic control or an iron-cored inductor (also known as a choke or ballast) is used, rather than the resistor used for DC supplies.

To understand how the control gear works, look at the process, using a fluorescent luminaire (low-pressure mercury discharge lamp) as an example.

The sequence of events in this discharge luminaire is as follows.

- 1 When the luminaire is switched on, the starter switch closes and current flowing through the inductor induces a magnetic field within the inductor. As the gas in the tube is cold, the voltage is not enough to break down the resistance.
- 2 The starter switch opens, which open circuits the inductor. This causes the magnetic field in the inductor suddenly to collapse, creating a high voltage. This voltage strikes across the tube, ionising the gas, which reduces in resistance, and completes the circuit.

ACTIVITY

Consult manufacturers' data sheets for circuit diagrams of high- and low-pressure sodium discharge lamps.

INDUSTRY TIP

Some discharge lamps will not restart immediately after being switched off; the pressure has to drop before they will restrike.

INDUSTRY TIP

Electronic starters prevent damage to the tube as they only allow a few attempts at starting, whereas a glow starter will continue to attempt to strike the tube.

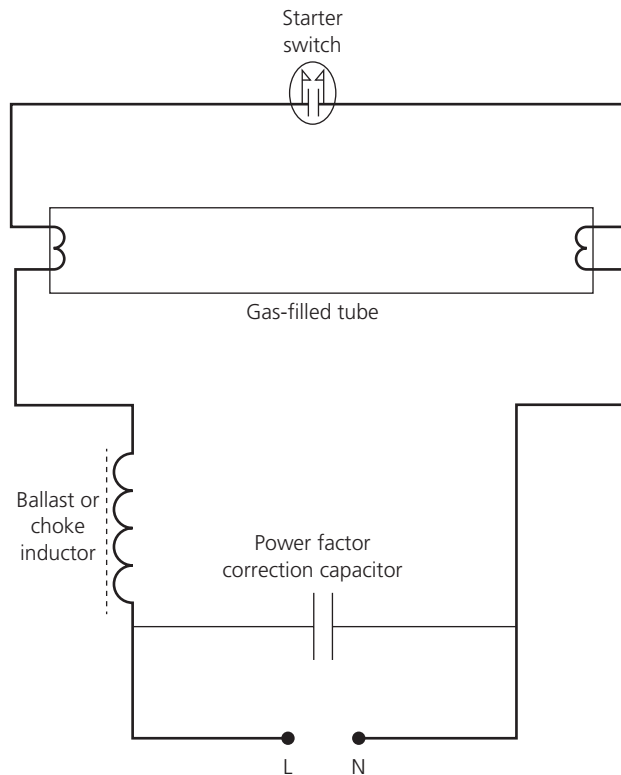

▲ Figure 2.105 How control gear works in a discharge lamp

- 3 With the circuit once again complete, current flows through the inductor, which re-induces a magnetic field, causing self-induction, which limits the current flow. The starter switch is no longer required as the gas remains ionised with a constant current passing through it.



▲ Figure 2.106 Switch starter unit

The switch starter

The switch starter is enclosed in a small glass tube containing neon gas, which glows and produces heat. The switch contacts are bimetals and the heat causes them to bend so that they touch.

When the fluorescent tube is lit, the current in the tube causes a voltage drop in the choke, so that the lamp voltage across the switch contacts is too low to cause a glow in the neon. As it is open circuit when unheated, the switch starter has no more effect on the luminaire circuit. If the tube fails to strike first time, the process repeats until striking is achieved.

Fluorescent tubes come in many lengths, shapes, colours and ratings.

Other types of discharge lamp

Other discharge lamps that work on a similar principle as the fluorescent tube (low-pressure mercury discharge lamp) above, include:

- high-pressure mercury
- low-pressure sodium
- high-pressure sodium
- metal halide.

ACTIVITY

Look on the internet at a wholesaler's website to see the various types of fluorescent tube.

High-pressure mercury (MBFU)

This type of lamp produces a near-white light with a blue tinge. It is commonly used for:

- amenity lighting
- street lighting in residential areas
- bollard lighting.

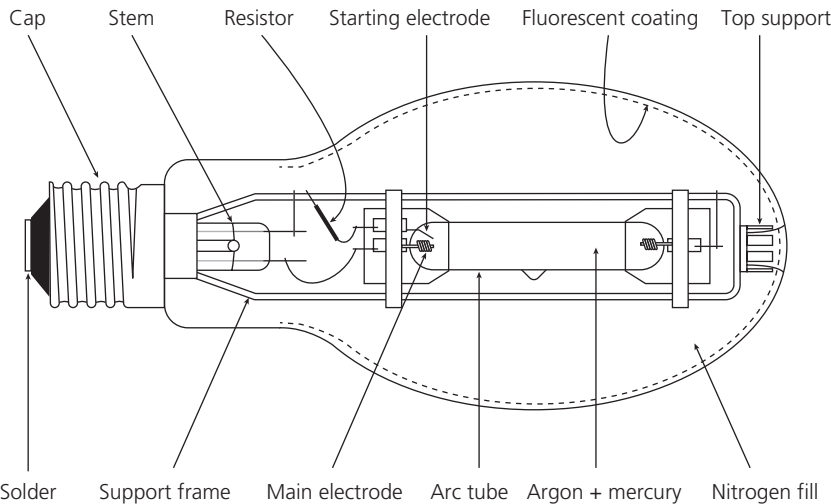

▲ Figure 2.107 High-pressure mercury lamp

Because of its good colour correction, it is good for CCTV applications or areas where coloured objects need identifying.

Low-pressure sodium (SOX)

As well as containing a low-pressure sodium gas, this type of lamp will also contain a neon-based gas that ionises at lower temperatures. The neon-based gas, which gives a pink appearance when starting, heats up the sodium gas, which then produces orange light.

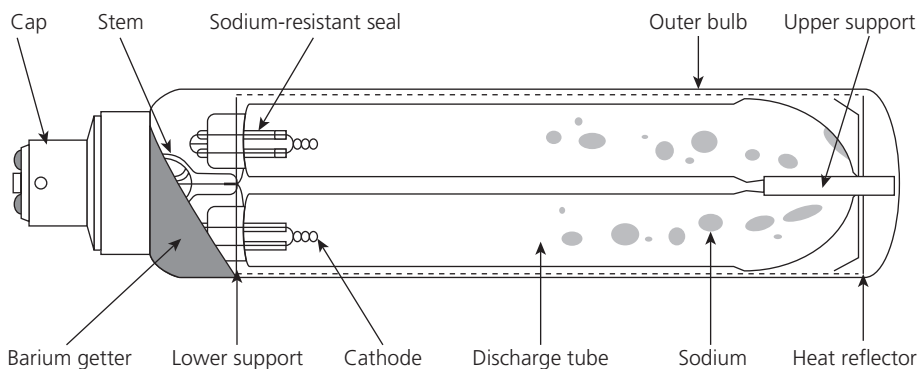

▲ Figure 2.108 Low-pressure sodium lamp

These lamps have poor colour rendering but very good efficacy. They were widely used for most roadway applications but, due to increasing use of CCTV in towns and on roads, they are slowly being phased out and replaced with high-pressure sodium lamps or LED lighting.

INDUSTRY TIP

M = mercury
 B = high pressure
 SO = sodium
 X = low pressure
 N = high pressure
 F = fluorescent coating
 E = external ignitor
 U = universal operation

INDUSTRY TIP

Older types of SOX lamp used a step-up auto transformer for starting. Modern types use an ignitor for starting.

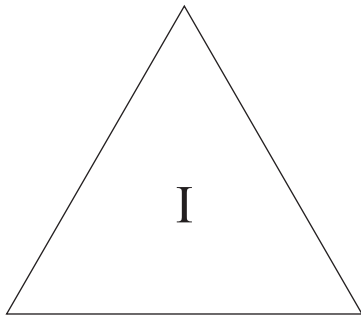

▲ Figure 2.109 This lamp has an internal ignitor switch

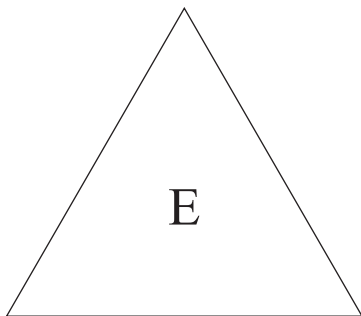

▲ Figure 2.110 This lamp requires an external ignitor switch

High-pressure sodium (SON)

These lamps are commonly used for street and amenity lighting as well as car parks, high-bay lighting and security perimeter lighting. They have reasonably good colour rendering although the light output is light orange. They have a good efficacy despite the colour rendering, which is why they are a common choice of lamp. They come in two varieties: SON-E elliptical and SON-T tubular.

Some lamps contain internal ignition (starter) switches, but others rely on separate starter units within the control gear. If you are replacing one of these lamps, make sure you check the type needed, which should be indicated by the appropriate triangular symbol.



▲ Figure 2.111 High-pressure sodium lamp

Metal halide (HID)



▲ Figure 2.112 Metal halide lamp

These lamps have excellent colour rendering and good efficacy. They are extensively used for sports arena floodlighting as well as general amenity or security lighting.

The Waste Electrical and Electronic Equipment Regulations 2006 (WEEE) and other environmental legislation place strict controls on the disposal of discharge tubes. Care is required when handling these tubes and lamps as the mercury in the tubes is toxic and the sodium in the lamps burns when in contact with moisture. It is therefore important that the tubes and lamps remain intact for specialist disposal.

Compact fluorescent lamps

These are miniature fluorescent tubes compacted into a small space. The control gear is contained in the base of the lamp. They are intended as energy-saving replacements for incandescent lamps although the colour rendering and flickering mean that many people find them difficult to use for reading or close work.



▲ Figure 2.113 Compact fluorescent lamp

LED lights

The LED is a light-emitting diode. These lights are usually made from inorganic substances such as gallium indium nitride and gallium phosphide. The colour of the light output depends on the material used for the diode. LED lamps now come in a variety of colours and colour temperatures, such as Daylight or warm white.

The light output is usually monochromatic, i.e. the light emitted is at a single wavelength. The most common way to create a white light is to apply a phosphor-based coating to a blue diode. The phosphor converts the blue light to white light in a range of colour temperatures. The quality of the white light is affected both by the choice of LED and by the properties of the phosphor.

LEDs are very small; the active light-emitting surface is no bigger than 1–2 mm². A single diode can rarely produce enough light for a given lighting situation. For the unit to work, it must be mounted on a circuit board, with multiple LEDs in a cluster to form an LED module.

LEDs can be powered in two ways: with constant current or constant voltage. The ballast, which is referred to as the driver, is the unit that drives an LED array.



▲ Figure 2.114 Basic LED colours

ACTIVITY
Using the internet, visit a wholesaler's website and look at the ways that LED lamps are rated. Consider why lamps have different methods of showing the output qualities.



▲ Figure 2.115 Retrofit LED lamp with cut-away showing internal parts

Although some LEDs run on conventional transformers, these can lack certain kinds of safety feature, such as short-circuit protection. When driven correctly, LEDs are claimed to be able to run for 50 000 hours, which is considerably longer than other technologies.

LED lighting technology has been evolving at such a fast rate that nobody, as recently as 2010, would have predicted that LED lighting would be used to illuminate sports arenas and street lighting as it does today.

PRINCIPLES AND APPLICATIONS OF ELECTRICAL HEATING

Heating buildings and work spaces using electricity is not the first choice for many building designers. It may however be the only choice when electricity is the only energy source available. This section looks at the principles of space and water heating. The principles of heating spaces are also applicable where other heat sources are used.

How electrical space heating and electrical water heating systems work

When current flows in a wire, apart from the flow of electrons, there is a thermal effect; the wire starts to heat up. The amount it heats up depends on factors such as the cross-sectional area of the wire, the amount of current flowing and the material that the wire is made of.

The heating effect of electricity is used in electrical heating systems such as electric fires, electric space heating and water heating.

Variations of this heat effect are also used to make light from light-bulb (lamp) filaments, which give off large amounts of light because they glow white hot as a result of the current passing through the thin filament.

Electrical space heating systems

The three ways to transfer heat from one medium to another are:

- convection
- conduction
- radiation.

Many heat sources use a combination of these methods.

Electrical water heating systems

There are many different types of electrically powered water heaters, including rod-type immersion heaters and instantaneous water heaters.

Operating principles of electrical space heating systems

Convection

Hot air rises and colder air falls through the process of convection. A simple convection panel heater mounted on a wall uses this principle to move warm air around a room.

A convection heater usually has a low-temperature 'black-heat' element. Air in contact with the element is warmed and becomes less dense, so that it rises and is replaced by colder air, which is then warmed in turn.

Some convection heaters heat up another medium by conduction. For example, the element can be submersed in oil. The oil transfers heat around the unit, giving a larger body of heat to start the convection cycle.

Traditionally, convection heaters such as central heating emitters (radiators) are positioned where colder air is present, such as under windows, as this produces a larger cycle effect. This is less relevant today as modern windows provide better insulation.

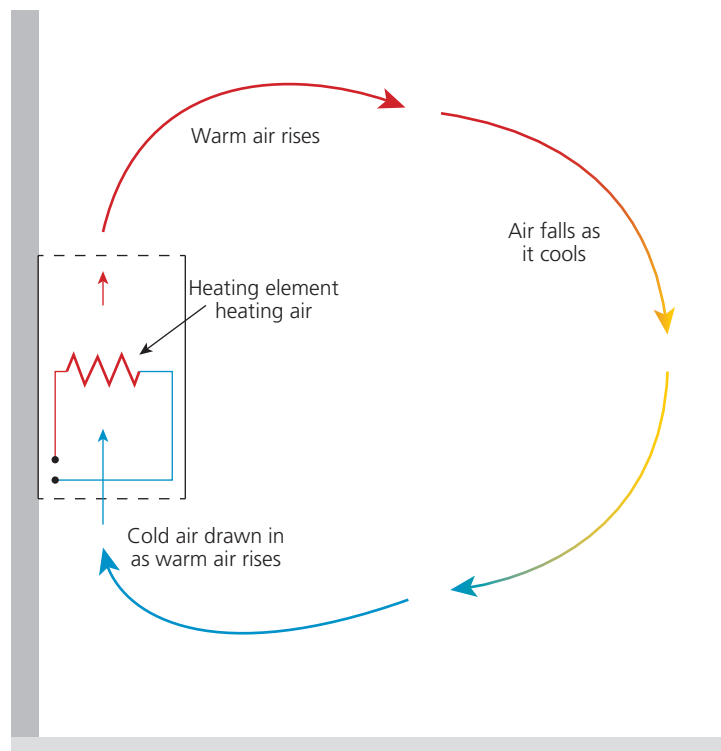

▲ Figure 2.116 Convection cycle

INDUSTRY TIP

Immersion heaters are usually considered for back-up heating, perhaps in conjunction with gas heating systems.

INDUSTRY TIP

Most heating devices use more than one of these methods of heat transfer.

Conduction

Conduction is the effect of heating something by direct contact. For example, the underfloor heating elements directly below a tiled floor warm the tiles and heat is transferred up through them. Similarly, in an immersion heater, a heating element is placed in water and the heat is transferred from the element directly to the water.

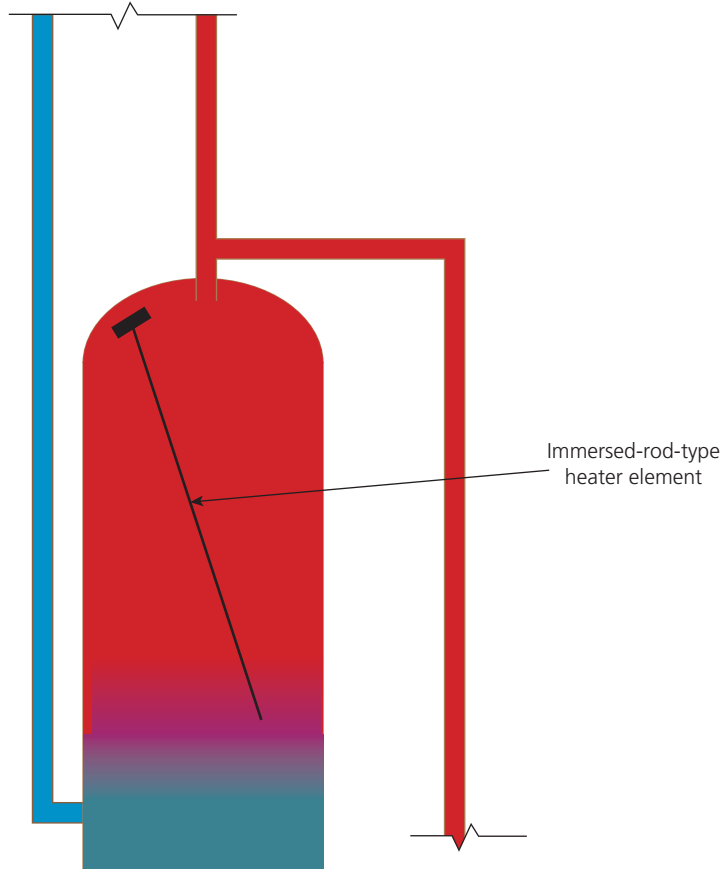

▲ Figure 2.117 Immersion water heater heating water by conduction

Radiation

In this process heat is radiated (or thrown out) from a source and warms objects nearby. A standard coal fire does this; the heat can be felt on surfaces facing the fire, but not on surfaces facing away from the heat source.

Radiant heaters include:

- traditional electric fires
- infrared heaters
- log-burning stoves.

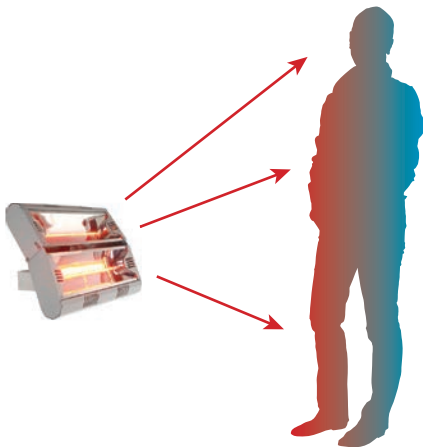

▲ Figure 2.118 Radiant heat

Heat sources

Underfloor heating

Underfloor heating systems have been around for centuries, although electrically powered versions have been available for a much shorter period. Since the 1960s the popularity of electric underfloor heating has fluctuated. In more recent times, it has become particularly associated with bathrooms and tiled areas. In many cases, underfloor heating is only installed in new houses or extensions as it is very costly to install into existing floors.

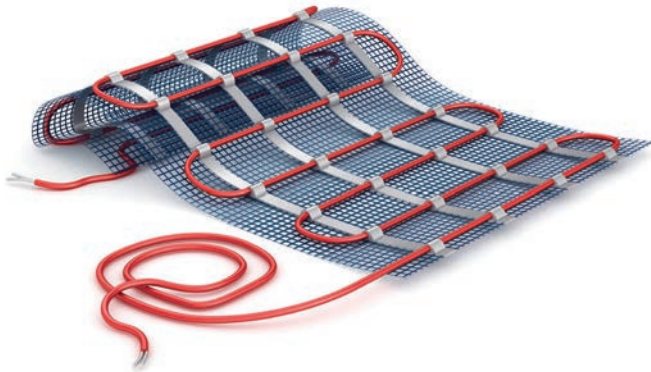

▲ Figure 2.119 Underfloor heating mat



▲ Figure 2.120 Electric underfloor heating before the final screed is laid

Underfloor heating is an effective system of transferring heat into the floor surface by conduction and then heating the room by radiant heat and convection. It is a very good way of providing a uniform heat in a space.

Storage heaters

Storage heaters charge up at night when energy is available at low cost on off-peak tariffs. The energy is then stored in the unit in fireclay blocks, which release it slowly during the day. Radiator-type and fan-type storage heaters are available.

The radiator type is heated by elements in fireclay blocks. The release of heat is controlled by insulation. The storage heater is sized to store enough heat to last all day, under controlled release conditions.

ACTIVITY
Name the tariff that should be used with storage heaters.

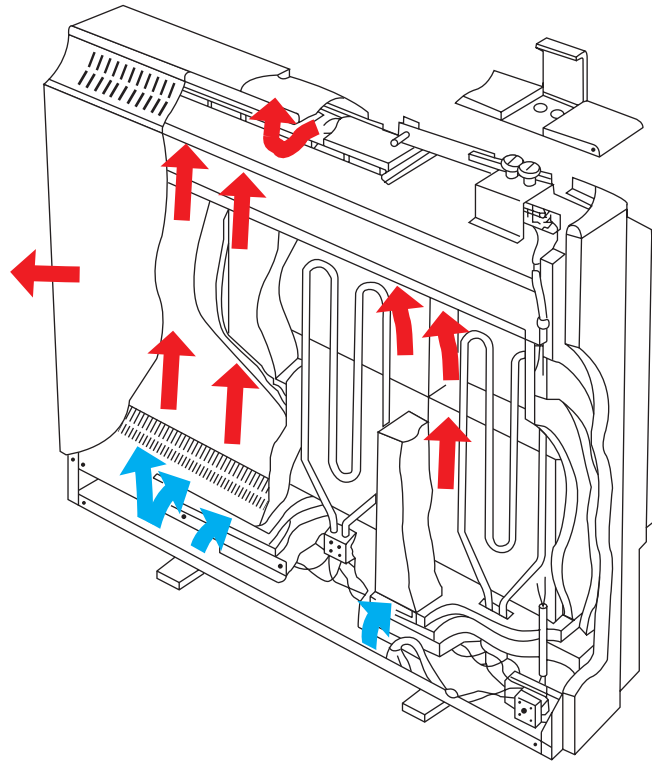

▲ Figure 2.121 Electric storage heater

Fan-type storage heaters have thicker insulation so that very little heat is lost. A small unit, on a 24-hour supply for the fan, will provide warm air controlled by a thermostat. Because of the fan, it is possible to use up the heating charge, so there is often a short boost option. However, daytime boosting is not an economical way to use storage heaters.

INDUSTRY TIP
Block storage heating tends to be retrofitted where the installation of a wet system could cause considerable disruption.

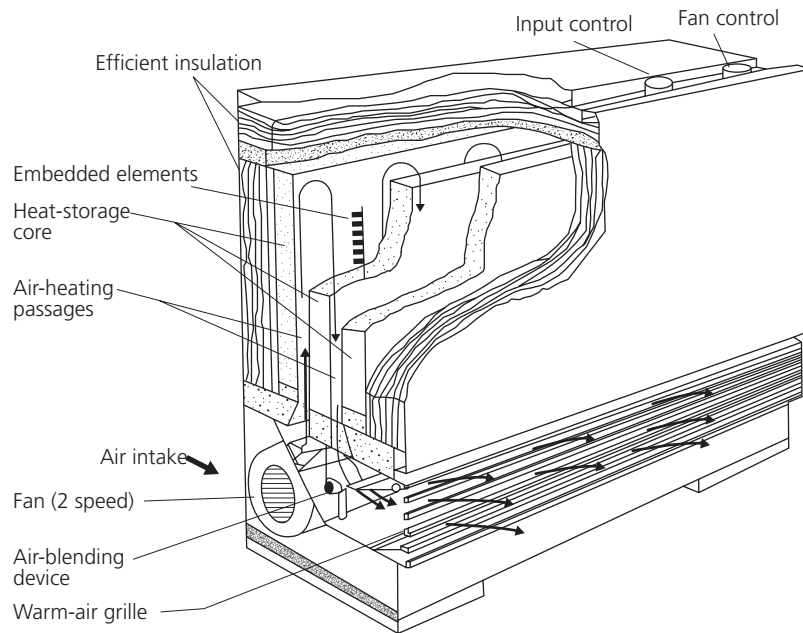

▲ Figure 2.122 Fan-assisted storage heater

The fan-assisted storage heater is usually larger and always noisier than the radiator-type equivalent.

Panel heaters

Panel heaters heat spaces by convection and radiation. They can be slim in design and can even be fitted to the front of storage heaters to provide daytime heating if the stored charge has been lost.

Most panel heaters are provided with thermostatic and time controls. Although they can be fairly expensive to run, they are often chosen as a means of heating reasonably small locations or locations where other services, such as hot-water central-heating systems, are difficult to install.

Radiant or infrared heaters

These types of heater are particularly useful in large, cold areas where heating the air is difficult. Examples are garage workshops and warehouses. The heat radiated warms bodies but not the air around them. They would work just as effectively in a vacuum.

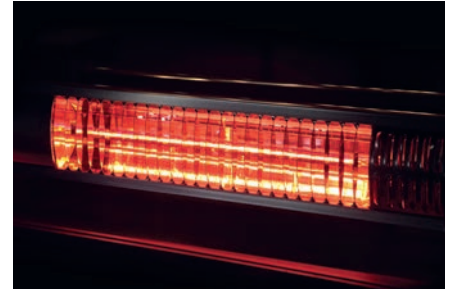

▲ Figure 2.123 An infrared heater

Operating principles of electrical water heating systems

Immersion heater systems

Immersion heater systems usually contain large amounts of water, which are heated over a period of time. The size of the vessel and limited amount of circulation and mixing allows relatively hot water to be used on demand. Then the heat is replenished over a period of time.

A large copper or stainless steel vessel is filled with water from a separate cold-water tank or sealed pressurisation unit. The vessel has an electric heater element fitted through a screw-threaded fitting, known as a boss.

The heater element can be the length of the cylinder, but in some instances two shorter elements are used, one positioned high and the other positioned low in the vessel. In domestic premises, the two heater elements used to be known as the 'bath and sink' function. By switching on the top element, just a small proportion of the water is heated, saving energy. This relies on the stratification process (i.e. hot liquids stay at the top) and works if the water is used before significant circulation takes place.

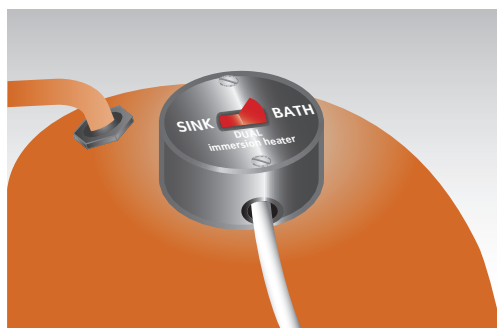

▲ Figure 2.124 Top entry boss with 'bath and sink' switch

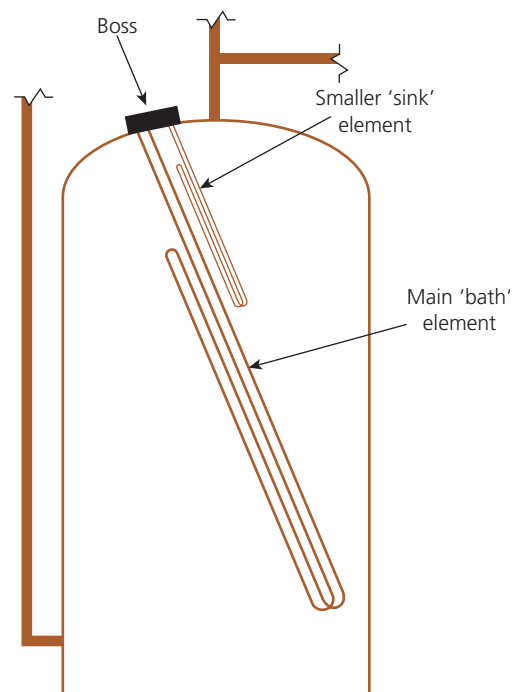

▲ Figure 2.125 Cylinder element arrangements



▲ Figure 2.126 Thermostat inside pocket in heater element

To ensure that there is a full tank of hot water, a longer element is fitted to heat the whole tank. Temperature is controlled by a rod thermostat fitted in a pocket tube in the head of the heater. However, there are also strap-on thermostats that fix to the exterior of the hot water cylinder. Many immersion heaters also have a thermal cut-out to open the element circuit, should the thermostat fail and the water reach dangerously high temperatures, which could lead to enormous pressures in the tank or the venting of scalding water through the overflow or expansion pipe.

In order to save energy, thermal insulation is added to the vessel during manufacture or a thermally insulated jacket is fitted after installation.

Instantaneous water heaters

There are many examples of instantaneous water heaters; most common are electric showers and point-of-use hand washers, fitted above or below sinks.

With all of these heaters there is a limit to how much water can be raised to a specific temperature in a given time. This depends on the flow rate. The slower the flow rate, the hotter the water will get.

There are two types of instantaneous hot-water system. The tank type is like a miniature hot water cylinder. In the other type, the elements wrap around the water pipe inside the unit.

INDUSTRY TIP

Water heaters should be supplied via a double-pole switch.

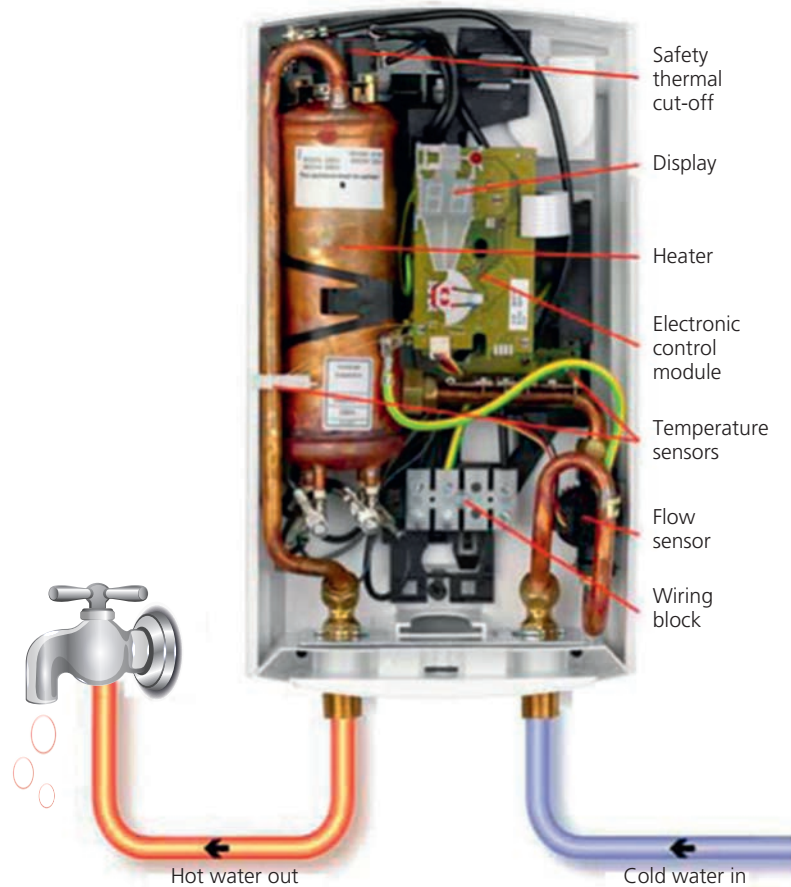

▲ Figure 2.127 Over-sink tank-type instantaneous water heater

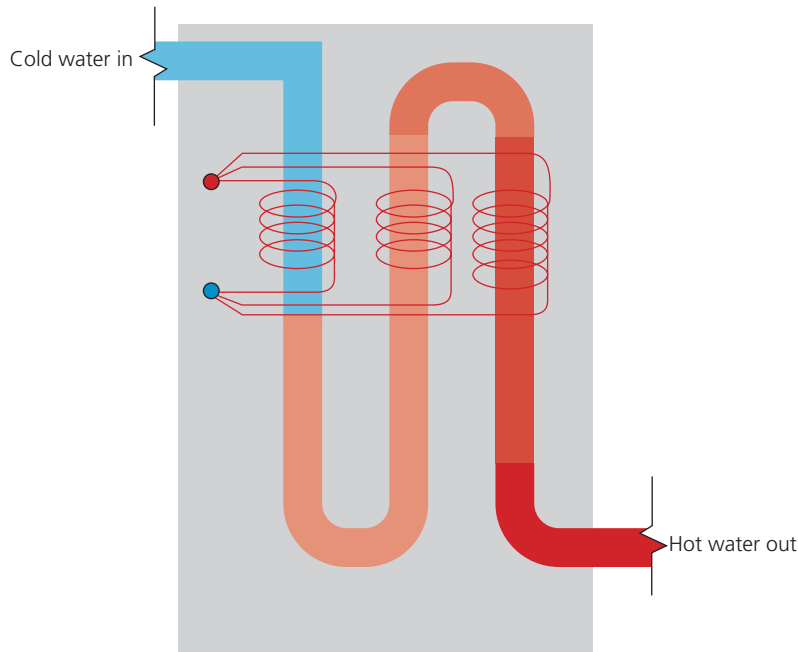

▲ Figure 2.128 Elements around the water pipe in an instantaneous water heater

How to control heating systems

Heating and hot-water systems are not controlled just for economic reasons. Control is also a legal requirement for safety reasons. Building Regulations demand control.

Room thermostats and control circuits

Room thermostats are used to provide temperature control when heating spaces. Traditionally, this is done by means of a simple adjustable bimetallic sensor incorporating a set of contacts. When the desired temperature is reached, the contacts open due to the bimetal bending. This stops water-based heating systems pumping heat around or, on more advanced systems, operates a valve that shuts off the water, but still heats water until it reaches the desired temperature, when the pump or boiler/heater will switch off.

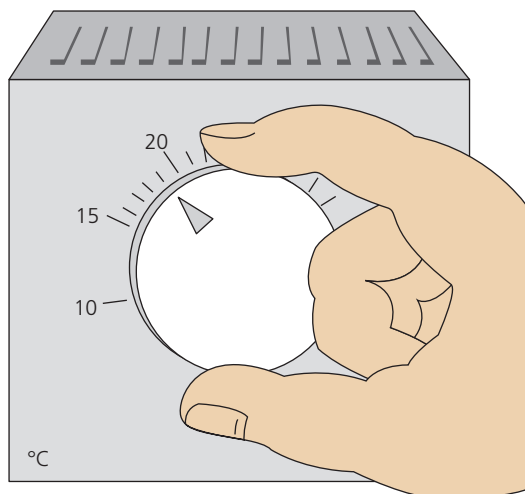

▲ Figure 2.129 Simple thermostat with bimetal

The valve control arrangement is always used in commercial premises as it gives more accurate and zoned control, as required by Approved Document L to the Building Regulations.

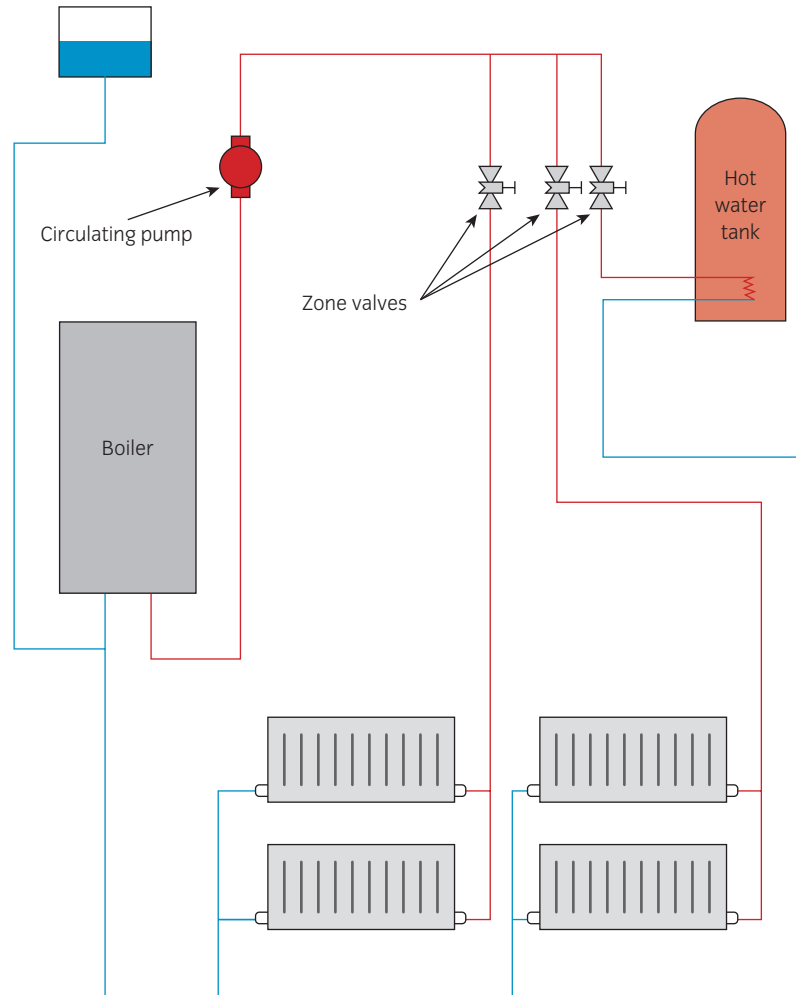

▲ Figure 2.130 Simplified central heating system



▲ Figure 2.131 Digital thermostat with temperature reading

As the bimetal thermostatic control is accurate to only plus or minus 3 degrees Celsius, many commercial and some domestic systems use digital thermostats containing temperature-sensitive electronic thermistors. These units give a signal that can be converted directly into a temperature, usually with an accuracy of up to 0.1 of a degree Celsius.

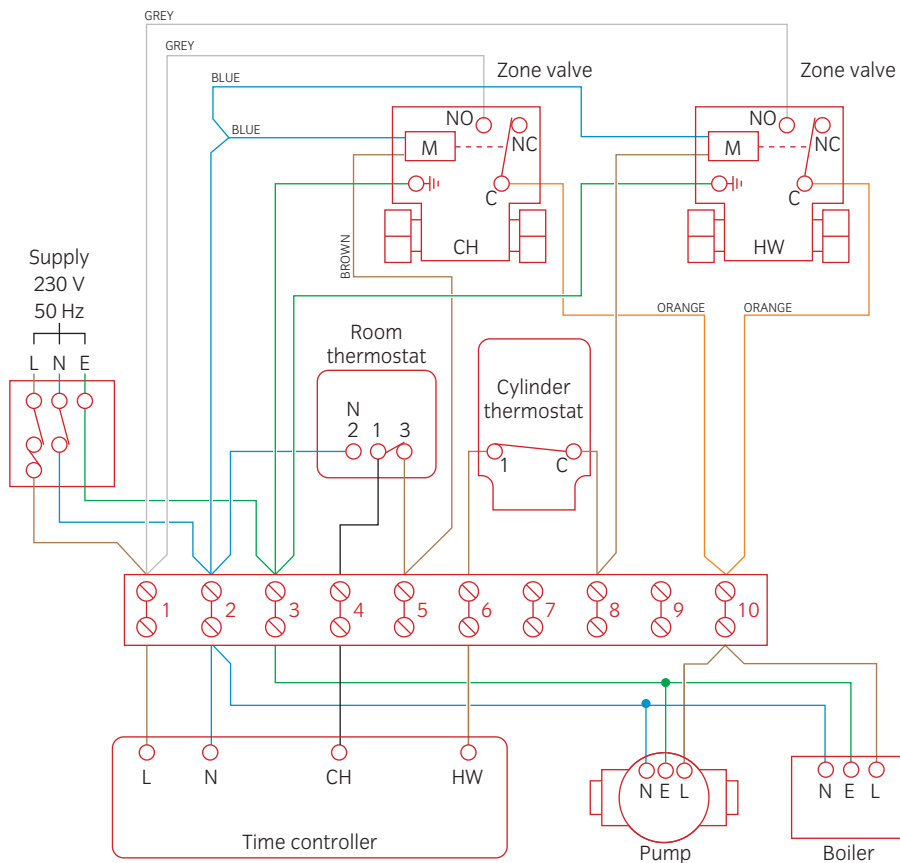

▲ Figure 2.132 Typical domestic central heating circuit diagram

Time switches and programmers

Time switches and similar devices are used to provide energy at the correct time and minimise wastage (e.g. not heating an office at weekends or a house when everyone is out).

In its simplest form, a 24-hour time switch cannot differentiate between days of the week. This is wasteful and a nuisance on days when the heating is required at different times from the norm. A programmable time controller is therefore normally installed as a minimum requirement for Building Regulations and convenience.

Simple domestic programmers allow the user to select the temperature required at set points on individual days of the week.

In commercial environments, controllers can be more sophisticated with optimum start functions. The user inputs the time at which they wish a specific temperature to be reached. The programmer uses thermostats to estimate the start-up time in order to reach the specified temperature and the time to switch off again in order to reduce the temperature at the end of the day.

INDUSTRY TIP

Most programmers have an over-ride facility to change the settings if the temperature drops suddenly or there is a heavy demand for hot water.



▲ Figure 2.133 Simple daily time switch

INDUSTRY TIP

Larger heating systems should be split into zones to allow accurate control.

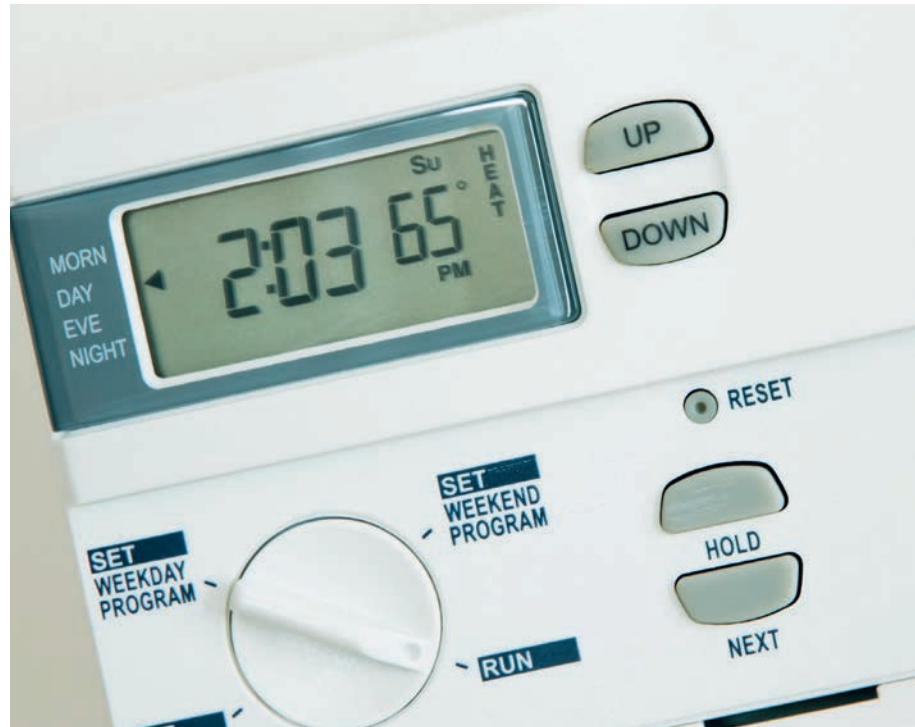

▲ Figure 2.134 Programmer

Taking into account the thermal mass of the building, and the actual temperatures inside the building, the system adjusts itself for the next day. As with all systems that use computers to estimate comfort conditions, this type of system is often criticised because British weather is very unpredictable and conditions can change rapidly.

Smart homes

Technology advancements in smart home automation now allow for heating, lighting and individual appliances to be controlled from anywhere using smartphone technology. These systems link to the WiFi system and can be controlled using internet connections from anywhere. In addition, these systems can be voice controlled, using voice interface systems such as 'Alexa' or 'Google Home'.



▲ Figure 2.135 Controlling home automation with smartphones

Test your knowledge

- 1 Which of the following is a distribution voltage maintained by distribution network operators?
 - a 400 kV
 - b 275 kV
 - c 33 kV
 - d 25 kV
- 2 What is the line voltage in a three-phase supply system in the UK?
 - a 400 V
 - b 315 V
 - c 230 V
 - d 110 V
- 3 What is the neutral current when all three phases in a system carry 40 A?
 - a 120 A
 - b 80 A
 - c 40 A
 - d 0 A
- 4 What is the common method used to reduce eddy currents in a transformer?
 - a Insulate the windings.
 - b Laminate the core.
 - c Reduce output windings.
 - d Use a plastic core.
- 5 What is the input current to a 400 VA transformer connected to a 230 V supply?
 - a 9.2 A
 - b 1.74 A
 - c 0.56 A
 - d 1.92 mA
- 6 What is the inductive reactance of a 12 mH inductor connected to a 230 V 50 Hz supply?
 - a 3769 Ω
 - b 19.1 Ω
 - c 3.77 Ω
 - d 1.88 Ω
- 7 How much current would be drawn by a 200 μF capacitor connected to a 100 V, 25 Hz supply?

a 6.28 A	c 2.85 A
b 3.14 A	d 1.28 A

- 8** What represents True Power?
- a** kVA
 - b** VAr
 - c** kW
 - d** $\cos \theta$
- 9** What type of motor has no physical electrical contact between the rotor and supply?
- a** Universal.
 - b** DC shunt.
 - c** DC series.
 - d** Induction.
- 10** What is the unit of measurement for the level of illuminance on a surface?
- a** Candela.
 - b** Lumens.
 - c** Efficacy.
 - d** Lux.
- 11** Determine the amount of neutral current on a three-phase circuit having the following loading.
- $L_1 - 100 \text{ A}$
 - $L_2 - 80 \text{ A}$
 - $L_3 - 40 \text{ A}$
- 12** Draw a diagram showing the outline shape of a shell-type transformer core.
- 13** Determine the output voltage and ratio for a transformer having an input current of 0.5 A and an output current of 6 A when connected to a 230 V supply.
- 14** Draw a phasor diagram showing the current and voltage relationship when a capacitor is connected to an AC supply.
- 15** Determine, using a scaled impedance triangle, the impedance of a circuit having a reactance of 6Ω and a resistance of 8Ω .
- 16** Determine the illuminance on a surface 3 m directly below a lamp having a luminous intensity of 90 cd.
- 17** Describe efficacy.
- 18** Explain the purpose of a centrifugal switch in a capacitor start induction motor.
- 19** Explain, with the aid of a diagram, the convection cycle.
- 20** Explain the operating process of a storage heater.

BS 7671: 2018 (2022) REQUIREMENTS FOR ELECTRICAL INSTALLATIONS

INTRODUCTION

Anyone who picks up a copy of **BS 7671** The IET Wiring Regulations, 18th Edition for the first time may well find it a daunting publication. However, once properly introduced to the resource, its structure and contents, you will soon be able to navigate it and ensure that your work complies with the Standard.

Nobody is expected to remember the entire contents of the **BS 7671: 2018 (2022)** The IET Wiring Regulations, 18th Edition Amendment 2. The ability to find what you need, and understand how what you read is relevant to your work, is the key to using the document.

INDUSTRY TIP

A solid understanding of BS 7671: 2018 (2022) The IET Wiring Regulations, 18th Edition will provide the grounding for all the core topics of electrical installation and design that you must master in later chapters.

T Level mapping grids are available on the Hodder Education website.

HOW THIS CHAPTER IS ORGANISED

This chapter begins by describing the structure of **BS 7671: 2018 (2022)** The IET Wiring Regulations, 18th Edition including Amendment 2. It then summarises the content of every chapter of the publication and explains some of the technical areas that apply to most electrical installations.

A good understanding of BS 7671: 2018 (2022) is necessary before you begin developing wider knowledge and skills in all aspects of advanced electrical design and installation. Some of this chapter relates to specific areas of advanced electrical design and installation, such as electrical installation design (covered in more detail in Chapter 5 of this book), inspection and testing (Chapter 6) and fault finding (Chapter 7). These topics are given coverage in this chapter to enable you to see how some of the design aspects are directly related to BS 7671: 2018 (2022) and to help you study them in context.

Table 3.1 shows the topics that are covered in this chapter.

▼ Table 3.1 Chapter 3 assessment criteria coverage

Topic	5357-018 Understand the Requirements for Electrical Installations BS 7671: 2018 (2022)	5357-004/104 Design and Installation Practices and Procedures	2365-305 Electrical Systems Design	8202-307 Requirements for Electrical Installations	8202-303 Electrical Design and Installation Practices and Procedures	5393 Electrotechnical in Dwellings Qualification
What is BS 7671 and how to use it						
Part 1: Scope, Object and Fundamental Principles	1.1; 1.2; 1.3			1.1; 1.2		1.1; 1.2; 1.3
Part 2: Definitions	2.1; 2.2			1.3		2.1; 2.2
Part 3: Assessment of General Characteristics	3.1	4.2	4.1; 4.2	1.4	1.1; 1.2	3.1

▼ Table 3.1 Chapter 3 assessment criteria coverage (continued)

Topic	5357-018 Understand the Requirements for Electrical Installations BS 7671: 2018 (2022)	5357-004/104 Design and Installation Practices and Procedures	2365-305 Electrical Systems Design	8202-307 Requirements for Electrical Installations	8202-303 Electrical Design and Installation Practices and Procedures	5393 Electrotechnical in Dwellings Qualification
Part 4: Protection for Safety	4.1; 4.2	4.3 5.1; 5.2; 5.3; 5.4; 5.5; 5.6; 5.7 6.1; 6.2; 6.3	4.3 5.1; 5.2; 5.3; 5.4; 5.5; 5.6 6.1; 6.2; 6.3	2.4	1.3 2.1; 2.3 3.1; 3.2; 3.3	4.1; 4.2 104/004 6.1; 6.2; 6.3
Part 5: Selection and Erection	5.1; 5.2	4.1 6.4	5.7 6.4	3.1	2.2	5.1; 5.2
Part 6: Inspection and Testing	6.1; 6.2			4.1		6.1; 6.2
Part 7: Special Installations and Locations	7.1; 7.2			5.1		7.1; 7.2
Part 8: Prosumers' Installations, and Appendices	8.1; 8.2			5.2		8.1; 8.2

WHAT IS BS 7671: 2018 (2022) AND HOW TO USE IT

BS 7671: 2018 (2022) The IET Wiring Regulations, 18th Edition Amendment 2 is intended to promote electrical safety. It sets out specific requirements in order to protect the following categories from the dangers and damages that may arise through the normal use of an electrical installation:

- persons
- livestock
- property.

BS 7671: 2018 (2022) is based on the harmonised documents (HDs) produced by the European Committee for Electrotechnical Standardization (CENELEC) and the International Electrotechnical Commission (IEC) Standards.

The BSI/IET Joint Technical Committee, called **JPEL/64**, reviews the HDs and the IEC Standards, then uses the technical content to implement the UK-specific Standard – **BS 7671**. Members of the JPEL/64 committee also represent the UK on the CENELEC and IEC committees.

Owing to the fact that BS 7671: 2018 (2022) is based on European and International Standards, many of the regulations within it are also implemented in other European countries. This means that if you have a good understanding of BS 7671 you will also have a relatively good understanding of the requirements for electrical installations in other European countries. One such European country is the Republic of Ireland, which has a similar publication – ET101: National Rules for Electrical Installations.

INDUSTRY TIP

The titles BS 7671 Requirements for Electrical Installations and the IET Wiring Regulations are used interchangeably.

KEY TERM

JPEL/64: A committee made up of representatives of many electrical industry organisations, the names of which are all listed in the front of BS 7671.

INDUSTRY TIP

The IET On-Site Guide (OSG) provides very useful interpretations of the requirements of BS 7671 for the most common electrical installations. This chapter will, from time to time, reference the OSG because it provides information in an easy-to-understand format.

The structure of BS 7671: 2018 (2022)

BS 7671: 2018 (2022) The IET Wiring Regulations, 18th Edition has eight parts that include regulations. Another section, the Appendices, contains information to assist you in using the publication.

The publication is structured in such a way as to follow the stages of the installation process. Table 3.2 (below) shows how that is achieved. In Table 3.2, note that the chapter numbers start with the part number. So, Chapters 11–13, which all begin with 1, are in Part 1. The numbering convention for sections and regulations will be covered later.

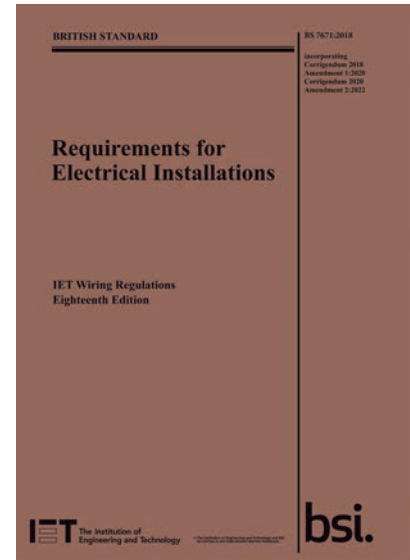

▲ Figure 3.1 BS 7671: 2018 (2022) The IET Wiring Regulations, 18th Edition Amendment 2

▼ Table 3.2 The structure of BS 7671: 2018 (2022)

Parts/Chapters	Titles	Process
Part 1 <ul style="list-style-type: none"> ● Chapter 11 ● Chapter 12 ● Chapter 13 	Scope, Object and Fundamental Principles <ul style="list-style-type: none"> ● Scope ● Object and Effects ● Fundamental Principles 	Before any electrical installation work is carried out, it is necessary to know the extent of the works. Part 1 specifies the types of electrical installation that are applicable to BS 7671: 2018 (2022). The Fundamental Principles set out all the principles that electrical installations should adhere to.
Part 2	Definitions	Part 2 defines any technical term used in the publication. It also includes tables that explain the meaning of symbols and abbreviations that feature.
Part 3 <ul style="list-style-type: none"> ● Chapter 31 ● Chapter 32 ● Chapter 33 ● Chapter 34 ● Chapter 35 ● Chapter 36 	Assessment of General Characteristics <ul style="list-style-type: none"> ● Purpose, Supplies and Structure ● Classifications of External Influence ● Compatibility ● Maintainability ● Safety Services ● Continuity of Services 	Before any work is designed or started, those responsible need to make general assessments of: <ul style="list-style-type: none"> ● the incoming supply, maximum demand and the types of circuits needed (Chapter 31) ● any external influences that will impact on the installed equipment, to assist with correct selection (Chapter 32) ● the equipment that is to be installed and how it impacts on the entire system (Chapter 33) ● the quality of the maintenance that the installation requires (Chapter 34) ● what, if any, safety services are needed, such as supplies for fire-service pumps (Chapter 35) ● any circuits where supplies need to be maintained by a generator or battery back-up, such as IT equipment or life-support equipment (Chapter 36).

INDUSTRY TIP

Using Part 2 is a bit like researching anything you are unsure of once you have established the scope of the works.

INDUSTRY TIP

You may notice that there are some gaps in the order of Chapters or Sections in BS 7671. This means they are either reserved for future use or not relevant to the UK.

▼ Table 3.2 The structure of BS 7671: 2018 (2022) (continued)

Parts/Chapters	Titles	Process
Part 4 <ul style="list-style-type: none"> ● Chapter 41 ● Chapter 42 ● Chapter 43 ● Chapter 44 ● Chapter 46 	Protection for Safety <ul style="list-style-type: none"> ● Protection Against Electric Shock ● Protection Against Thermal Effects ● Protection Against Overcurrent ● Protection Against Voltage Disturbances and Electromagnetic Interference ● Isolation and Switching 	<p>Part 4 covers the hazards associated with electricity and how to reduce them.</p> <p>For example, one of the greatest hazards is electric shock (Chapter 41) and one of the greatest risks of getting an electric shock is touching something that is supposed to be live, such as a conductor or a terminal. So, in Chapter 41, Section 416 (the sixth section in Chapter 41), the measures given are:</p> <ul style="list-style-type: none"> ● insulation (for the conductors) and ● barriers/enclosures (for the terminals).
Part 5 <ul style="list-style-type: none"> ● Chapter 51 ● Chapter 52 ● Chapter 53 ● Chapter 54 ● Chapter 55 ● Chapter 56 	Selection and Erection <ul style="list-style-type: none"> ● Common Rules ● Wiring Systems ● Isolation and Switching ● Earthing Arrangements and Conductors ● Other Equipment ● Safety Services 	<p>Once an electrical system has been designed, it needs to be installed. Part 5 sets out the requirements associated with the selection and erection of the electrical system.</p> <p>Part 5 also sets out the requirements pertaining to:</p> <ul style="list-style-type: none"> ● cable colours, for identification purposes (Chapter 51) ● minimum sizes of cables and cable support methods (Chapter 52) ● devices that are suitable for isolation (Chapter 53) ● minimum sizes of protective conductors (Chapter 54) ● lighting installations (Chapter 55) ● permitted safety services (Chapter 56).
Part 6 <ul style="list-style-type: none"> ● Chapter 64 ● Chapter 65 	Inspection and Testing <ul style="list-style-type: none"> ● Initial Verification ● Periodic Inspection and Testing 	<p>Once a system has been designed, selected and installed, not only must it be initially verified (Chapter 64) but also inspected regularly and tested periodically (Chapter 65).</p>
Part 7	Special Installations and Locations	<p>Most common installations will be designed, erected and tested to a safe standard if the regulations outlined in Parts 1–6 have been followed.</p> <p>There are, however, some installations or locations that pose greater risk. These are listed in Part 7 and, depending on the risk, the regulations in Parts 1–6 need to be adapted to suit that higher risk. This is what Part 7 does and the numbering system reflects this.</p> <p>Regulation numbers in Part 7 start with the section location number (e.g. 701 for bathrooms) and then use the relevant regulation number from Parts 1 to 6.</p> <p>For example, Regulation 415.2 states requirements for additional protection. When that regulation is adapted to suit a bathroom, the regulation number becomes 701.415.2</p>

INDUSTRY TIP

Part 4 is essentially a risk assessment of what could go wrong and the measures to put in place to mitigate risk.

KEY TERM

Load shedding is where technology is used to monitor loading of the electrical supply and turns off any excessive loads that could be used at times of lower demand, such as washing machines.

Parts/Chapters	Titles	Process
Part 8 ● Chapter 82	Functional Requirements Prosumer's Low-voltage Electrical Installations	Part 8, introduced in Amendment 2 in 2022, introduces Prosumer Electrical Installations (PEI) . These are installations that not only consume electricity but have load shedding capabilities as well as means of generating and/or storing electricity.
Appendices	Appendices 1–17 Information	The Appendices contain information to support the regulations. This information includes tables showing current-carrying capacities and voltage drop for different cables, as well as graphs giving the disconnection times of protective devices based on the level of fault current. Sample forms used for inspection and testing are also contained in the Appendices, among other things.

Table 3.2 should hopefully demonstrate to you that there is a clear and formulaic structure to BS 7671 that you can learn to navigate.

Think of the structure of BS 7671 as following the process for installing an electrical system:

- Part 3: Survey the job
- Part 4: Risk assess and design
- Part 5: Select and install the equipment
- Part 6: Inspect and test
- Parts 7 and 8 relate to installations that have greater risks or different technologies and how these are arranged.

INDUSTRY TIP

At the beginning of BS 7671 there is a contents page that lists the Parts that are in the book and where to find them. Every Part has a contents page, then every Chapter has a contents page, too. In all cases, the contents pages list the topics covered in the Part/Chapter and where to locate them.

Be aware that not all regulations are regulations; some regulations are considerations! What this means is that you will not necessarily make something unsafe if you do not comply with them, but it is regarded as good practice to adhere to them. Considerations are easily identifiable in BS 7671 through use of the word 'consideration' in the text.

BS 7671: 2018 (2022) numbering system and navigation

You may have noticed by now that there is a pattern to the numbering system used in BS 7671. You can gain much information just from a regulation's number.

Let's consider Regulation 514.15.1.

INDUSTRY TIP

Any regulation that ends in a 200 series number is specific to the UK; for example, 433.1.204.

Part	5	Selection and Erection
Chapter	51	Common Rules
Section	514	Identification and Notices
Subsection	514.15	Warning Notices: Alternative Supplies
Regulation	514.15.1	The first regulation relating to a notice for alternative supplies

This example demonstrates how in BS 7671 navigation to regulation numbers through use of the contents pages is sometimes easier than via the index.

With a bit of familiarity, you will begin to know the Parts, Chapters and even Section numbers.

Imagine you needed to know the minimum cross-sectional area (csa) of a **main protective bonding conductor**.

- **csa-sizing** is selecting; this has to be in Part 5 of BS 7671.
- Look at the contents page for Part 5 to locate **main protective bonding conductor**. You will see that Chapter 54 deals with protective conductors.
- Look at the contents page for Chapter 54. You will see that **bonding** conductors are in Section 544; specifically, information on **main** protective bonding conductors is to be found in 544.1.

IMPROVE YOUR ENGLISH



Always use key words to navigate through the contents pages. Key words are informative and significant words that can indicate the content of the text.

Legal status

BS 7671: 2018 (2022) The IET Wiring Regulations, 18th Edition, Amendment 2 is a **non-statutory** document, but it could be used in a court of law. If you follow the guidance given in the document, the installed equipment will comply with the requirements of the statutory (legally binding) regulations, such as:

- Electricity at Work Regulations (EWR)
- Building Regulations (or Standards for Scotland)
- Electricity Safety, Quality and Continuity Regulations
- other legal documents, which are specified in Appendix 2 of BS 7671.

The statutory regulations listed above may be used as a tool for prosecution in a court of law should something go wrong within an electrical installation and create an unsafe situation. If the installation was not designed, erected or inspected and tested to BS 7671, then it could be judged that the installation was **not** safe or suitable, and that then means the person responsible could be prosecuted.

Why do regulations change?

Amendment 2 of BS 7671, published in March 2022, is the sole regulations from September 2022, and as is the case with any amendments, the publication date is six months earlier than the implementation date to allow for a period of transition from the old Standards to the new.

Installations that were designed, erected, inspected and tested during the transition period of March 2022 to September 2022 may comply with:

- **BS 7671: 2018** 18th Edition including Amendment 1
- **BS 7671: 2018 (2022)** 18th Edition, Amendment 2.

INDUSTRY TIP

Using the index pages in BS 7671 can be useful to find something but may also give you too many options. If you know you are looking for a table or diagram, use the Table of Figures and the Table of Tables just before the Index pages.

KEY TERM

Non-statutory: Not a legal document or requirement, but a good practice guide. See Section 114 of BS 7671.

INDUSTRY TIP

The 17th Edition was permitted three amendments before the edition changed to the 18th. This was because Amendment 2 was simply the introduction of one section (Electric Vehicle Charging Installations) and that was an insert of a few pages. The main contents of the book did not need reprinting; the new pages just formed an insert.

BS 7671 needs to constantly change to keep up with technological advances and the risks they introduce to the electrical installation process. For example, since the publication of Amendment 3 of the 17th Edition, many gas supply companies have begun to install non-metallic inserts in their gas pipes, by the meter position. This has had a huge impact on the main bonding to the gas installation pipework so, when the 18th Edition was published, new requirements were added to address this issue.

KEY TERM

BSO: The British Standards Institution document that sets the rules for all BS documents such as BS 7671.

Due to the massive rate of technological advances, and therefore practices and procedures, it is expected that BS 7671 will change every three to six years. The rules of the **BSO**, which governs BS 7671, state that an edition can only be amended and therefore reprinted twice; after that, a new edition must be issued. This means that we can expect to see the 19th Edition of BS 7671 sometime between 2025 and 2029.

So, what is likely to be the cause of future amendments? Supplies to personal teleportation devices, induction-powered appliance supplies or the wiring to 3D-printed food production machines in domestic kitchens! Who knows? But one thing is certain, technology is changing faster now than at any time before.

PART 1: SCOPE, OBJECT AND FUNDAMENTAL PRINCIPLES

In the following sections of this chapter, it is a good idea if you have a copy of BS 7671: 2018 (2022) The IET Wiring Regulations, 18th Edition Amendment 2 to refer to. The rest of this chapter provides a summary of each chapter and most sections of BS 7671. Sections of BS 7671 that are not covered are considered too advanced or specialist for this book.

Chapter 11: Scope

Part 1 sets out the scope of BS 7671.

Regulation 110.1.1 gives a comprehensive list of the installations that BS 7671 applies to.

Regulation 110.1.2 clarifies the voltage ranges and aspects of a building or premises that BS 7671 applies to.

Owing to the large range of installations covered by the scope of BS 7671, it is sometimes easier to see what is *not* covered. Regulation 110.2 lists the systems that BS 7671 does not apply to.

Chapter 12: Object and Effects

Chapter 12 states the rationale for BS 7671 and explains that the technical content (in Parts 3 to 7) is the most susceptible to change in the event of technical developments.

ACTIVITY

Consider the potential causes of injury, as given in Regulation 131.1, and write down a situation that could cause each of them to happen.

Chapter 13: Fundamental Principles

The fundamental principles detailed in Chapter 13 of BS 7671 are the basis of all the regulations in that they are the minimum standards for safety – they are the building blocks of the regulations. Regulation 131.1 lists the potential causes of injury or damage to persons, livestock and property.

The fundamental principles can act as a designer's and an installer's checklist of considerations to make an installation safe and suitable.

As an example, Section 132 gives principles that a designer must consider. In particular, 132.6 lists conditions that must be taken into account when determining the cross-sectional area of conductors.

Section 133 gives principles relating to the selection of equipment, and Section 134 relates to the installation and initial verification of the equipment.

Although the fundamental principles are not detailed or technical, they give the commonsense requirements, and these have to be stated somewhere.

PART 2: DEFINITIONS

Part 2 is not divided into chapters as it simply provides definitions of technical terms used throughout BS 7671. Part 2 effectively looks like and works like a glossary, with the term in bold, followed by the definition.

Where some technical terms are specific to particular sections of BS 7671, section numbers are given alongside the term. If no section number is quoted, then that term is used in several places.

Another feature of Part 2 is the two tables at the end. These tables explain:

- all the symbols used in BS 7671, with their meaning and an example of a regulation where they can be seen
- all the abbreviations used in BS 7671, with their meaning and an example of a regulation where they can be seen.

ACTIVITY

Using the symbols table in BS 7671 determine the correct symbol for:

- the sum of the resistances of the earth electrode and the protective conductor connecting it to the exposed conductive parts
- nominal AC rms or ripple-free DC line voltage to earth
- current causing the operation of the protective device within the specified time.

PART 3: ASSESSMENT OF GENERAL CHARACTERISTICS

Part 3 is where the technical detail of BS 7671 starts. General characteristics are all the things that need to be considered when designing an electrical installation. As an example, Section 311 deals with the supply characteristic. With no electrical supply, there would be no electrical installation!

INDUSTRY TIP

Consider the importance of commonsense requirements. Imagine the risks involved if it didn't state somewhere in BS 7671 that electrical design must be carried out by someone skilled (electrically).

INDUSTRY TIP

You will probably be familiar with some of the terms, symbols and abbreviations in BS 7671 but there will be others that you will not have encountered before. It is a good idea to memorise the common ones and know what they mean. You can also check the last few pages of Part 2 for a list of the common symbols used.

Part 3 is likened to a site survey before any design or work commences. If there is no site yet, because it is a new building, then discussions with clients and studying drawings are both essential to assess the characteristics.

KEY TERM

Maximum demand: The total demand of an installation at full load.

INDUSTRY TIP

Chapter 5 of this book covers how to determine maximum demand and apply diversity.

HEALTH AND SAFETY

If you are assessing an existing TN-C-S earthing system (protective multiple earth (PME) supply), make sure you check for diverted neutral current flow before anything is disconnected. This is done by using a clamp-on ammeter and ensuring that no current is present on the earthing conductor or any main protective bonding conductors, due to open circuit protective earthed neutral (PEN) conductors.

Chapter 31: Purpose, Supplies and Structure

The factors related to supply that need to be considered before any work is undertaken are dealt with in Chapter 31 of BS 7671 in the following sections.

Section 311

An assessment of the **maximum demand** likely to be placed on a system must be made, taking diversity into account. A diversity assessment involves the designer checking that the supply needed for the entire installation is never exceeded if maximum demand is placed on every load (or separate part) in the system at the same time.

Section 312

Much of an installation's design and the protective measures employed will depend on the type of conductor and the earthing arrangements of the supply.

Conductor arrangements

In the UK, supply conductors can typically be:

- single-phase two-wire, as shown in Figure 3.1 in BS 7671; or
- three-phase four-wire, as shown in Figure 3.5 in BS 7671.

Other types of conductor arrangement are not common but may be encountered, such as the two-phase three-wire system, shown in Figure 3.3 in BS 7671 with a phase angle of 180°. These arrangements are typically found as 110 V reduced low-voltage construction site supplies.

Earthing arrangements

There are typically three earthing arrangements that are used in the UK: TN-C-S, TN-S and TT.

- In TN-C-S (earth-neutral-combined-separate) arrangements the installation's means of earthing is the combined neutral/earth (CNE) of the supply, otherwise called the protective earthed neutral (PEN). This arrangement is also referred to as a PME arrangement (protective multiple earth).
- In TN-S (earth-neutral-separate) arrangements the installation's means of earthing is a separate supplier's earth, usually the supply cable sheath.
- In TT (earth-earth) arrangements the installation's means of earthing is an earth electrode.

TN-C-S

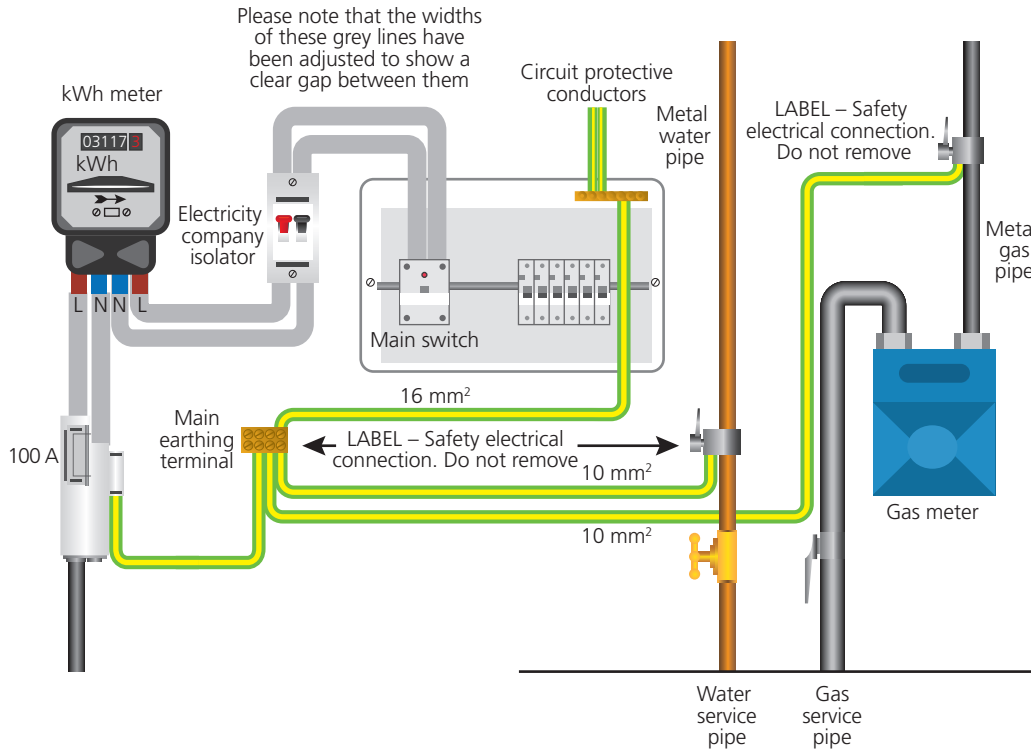

▲ Figure 3.2 Domestic TN-C-S earthing system

TN-C-S arrangements combine the earth and neutral conductors as one in the supply. This brings advantages because the earth fault loop impedance of the supply network can remain low as the neutral/earth or PEN is a copper conductor. As a result, distribution network operators (DNOs) declare that they will try to maintain Z_e for a TN-C-S system below 0.35Ω , and while that is common, it is not always the case.

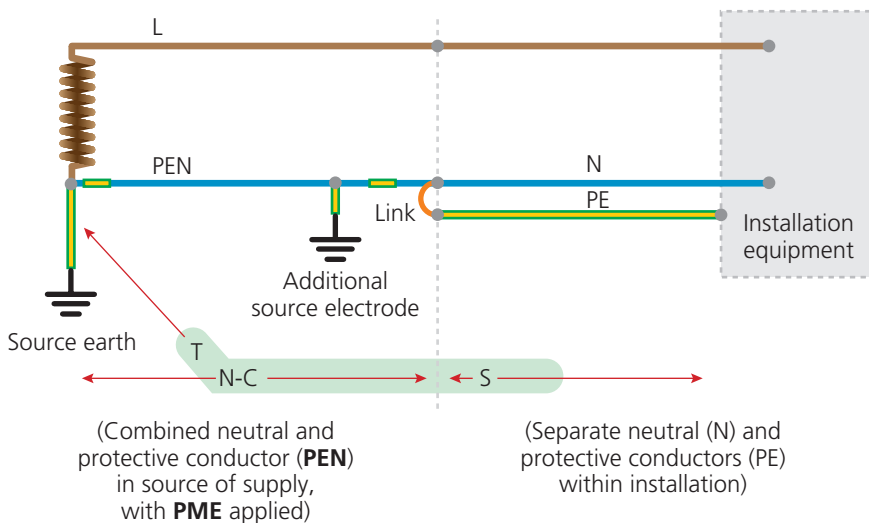

▲ Figure 3.3 TN-C-S earthing system

INDUSTRY TIP

Where one building system supplies another by a distribution circuit, and the supply is PME, this is often referred to as exporting PME. A risk assessment should always be carried out when exporting PME to decide if the PME creates a risk due to increased contact with the installation earth and the mass of earth.

To enable the earth and neutral to be separated in the installation, the earth is connected to the neutral (PEN) conductor at the supplier's service head (cut-out). Because of this, the earth is connected to a conductor that carries current. So, a risk with PME systems is that, should an open circuit occur in the supply PEN, earthed parts of the system will carry a current as the current tries to find alternate routes back to the substation transformer. To overcome this, additional source electrodes are connected to the PEN to provide those paths through the general mass of earth.

One major problem is that metal rods in the ground corrode. This corrosion means that the protective multiple earth is lost, leaving the installation earths connected to the PEN, prone to becoming live in the event of a high resistance or open circuit PEN conductor.

If source electrodes corrode and an open-circuit PEN occurs, neutral currents are then diverted through the earthing system and extraneous parts as shown in Figure 3.4. These could include the earthing and extraneous parts of neighbouring properties.

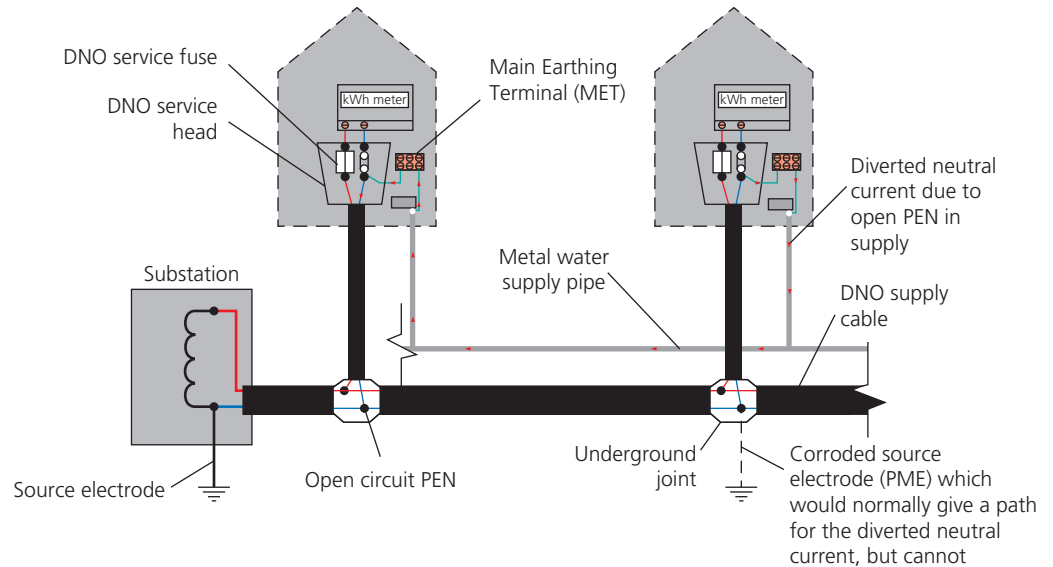

▲ Figure 3.4 The risk of diverted neutral current due to an open circuit PEN conductor

HEALTH AND SAFETY

It is important to get into the habit of checking for diverted neutral currents by checking for current on any earthing or bonding by using a clamp-on ammeter. It could one day save your life before you disconnect an earth or bond clamp.

As a result, the main equipotential bonding conductors on PME systems must be larger than other systems (see Section 544 of BS 7671: 2018). Furthermore, Electricity Safety, Quality and Continuity Regulations (ESQCRs) will not permit certain installations to be connected to a PME system, as earthed parts becoming live could create risks of explosion or shock. These include installations at:

- petrol stations
- construction sites
- caravan parks.

Other industry guidance also states that certain outbuildings, such as metal framed and clad buildings, should not be supplied from a PME system and instead should be converted to TT at that point.

In some commercial installations, the DNO will not grant a supply unless the consumer provides an earth electrode that acts as an additional source electrode but is maintained by the consumer, not the DNO.

TN-S

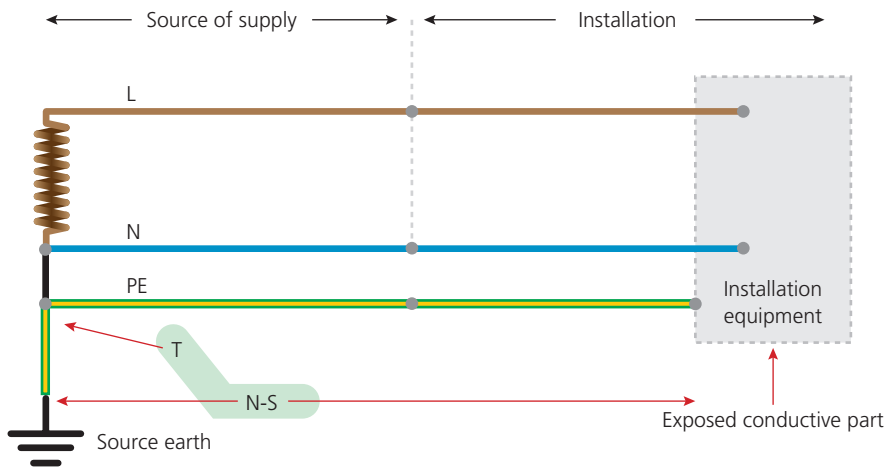

▲ Figure 3.5 TN-S earthing system

TN-S arrangements often use the lead sheath of the cable as the protective conductor. Although many TN-S arrangements still exist, the savings made by installing or maintaining one fewer conductor is the reason for electricity distribution companies converting TN-S distribution systems to TN-C-S.

TN-S earthing arrangements are often adopted for large installations supplied by their own transformer. They are also found in old (circa pre-1970) domestic installations.

TT

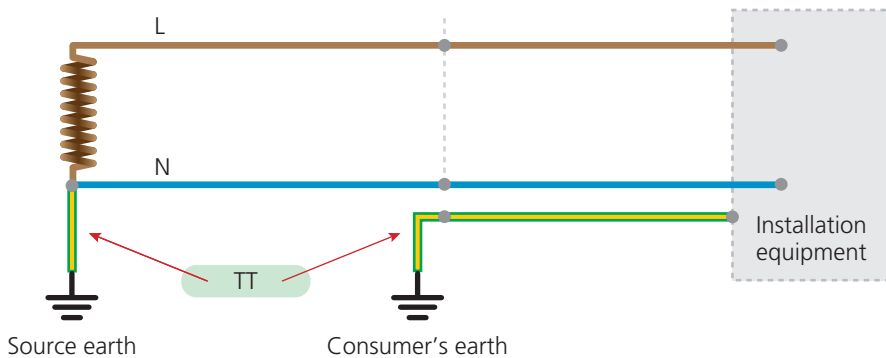

▲ Figure 3.6 TT earthing system

Electricity suppliers will often refuse to provide PME to certain installations, such as temporary supplies to construction sites. This is because of the difficulty of bonding all connections with earth together in a site and the risks of an open circuit PEN conductor causing circuit current to find an alternate path. Because the earthing of a PME system comes from the neutral, if current cannot flow back to the substation via the neutral, it will use the connected earth path instead.

INDUSTRY TIP

The issues with PME networks will only increase as infrastructure ages. **BS 7671** will always need to adapt to address these issues, an example of which is the introduction of foundation earth electrodes, where an earth electrode is built into the foundation of buildings (see Regulations 542.1.2.202, 542.2.2 item iv and 542.3).

The installation must then have its own independent earth, not connected to the supply, and the installation becomes TT. The connection to Earth for an installation forming part of a TT system will use an earth electrode as a means of earthing. A complete list of what is accepted as an earth electrode can be found in Chapter 54 of BS 7671.

INDUSTRY TIP

Remember that the nominal voltage and frequency can only be determined by enquiry. If you measure it, it is likely to be different to the nominal values of 230/400 V 50 Hz.

Other earthing arrangements

Other earthing arrangements include TN-C. In these arrangements, the neutral and earth are connected throughout the supply and installation. However, because residual current devices (RCDs) are used as protective devices in most installations in the UK, and RCDs will not operate if the neutral also carries an earth fault, TN-C systems are not permitted in the UK. Isolated or impeded earth (IT) systems may be encountered in the UK, but these are reserved for specialised areas.

Section 313

Regulation 313.1 requires the designer of an installation to determine supply values, such as external earth fault loop impedance (Z_e) and prospective fault current (PFC). This information can be obtained by measuring or, if no supply is available, by making enquiries with the distribution network operator.

Section 314

This section includes the requirement for every installation to be divided into circuits, taking into account Regulations 314.1 to 314.4. Regulation 314.4 states that every circuit shall be independent, which means that all circuits must have their own line and neutral conductors and, in most cases, circuit protective conductor (cpc).

Chapter 32: Classifications of External Influence

Chapter 32 of BS 7671 is one of the most important chapters when deciding on the type of wiring system to install and the equipment to use. External influences are all the factors that will need to be considered for their possible impact on the installed equipment; for example:

- environment – temperature, moisture, heat and so much more
- utilisation – who uses the building
- building – what the building is constructed of.

Chapter 33: Compatibility

The compatibility of the parts intended for installation needs to be assessed to make sure that one part does not have a detrimental effect on another part. For example, if a machine has high starting currents, this will put a strain on the supply system, causing lights to dim each time the machine starts. As a result, the designer must specify a soft start, thereby reducing the high start-up current.

Chapter 34: Maintainability

A designer is required to assess the frequency and quality of maintenance that installed equipment is likely to receive. It is the designer's responsibility to set the time period between initial verification and the first periodic inspection. This will be based on the quality and suitability of the materials used and the likely maintenance they will receive.

Chapter 35: Safety Services

Some installations may require standby (back-up) supplies so that power is maintained in the event of an emergency. Standby supplies could be necessary for water pumps, in order to operate sprinkler systems, or for fire-detection systems. The designer must assess how these standby supplies will be provided. Options include the use of generators and batteries.

Chapter 36: Continuity of Services

Some circuits require a continuous supply of electricity. An example is circuits for life-support systems. A designer must assess how electricity to these circuits will be maintained in the event of an emergency. A possibility is an uninterrupted power supply (UPS) on that circuit. Another option may be the use of an impeded earth (IT) earthing system and monitors instead of circuit breakers, meaning the supply will not disconnect in the event of a fault.

PART 4: PROTECTION FOR SAFETY

Part 4 of BS 7671 focuses on what could go wrong with an electrical installation and gives methods of fault protection.

An example of a hazard is electric shock caused by contact with a part that is live, such as a terminal in a light switch. To protect against electric shock, Section 416 states that every terminal must be housed in an enclosure that is secured and can only be accessed by using a tool. This means that – assuming the light switch is not damaged – the only way someone can get a shock from a terminal is by using a screwdriver to get to it!

The four main risks associated with electricity are:

- electric shock (Chapter 41)
- fire or heat, known as thermal effects (Chapter 42)
- overcurrent, such as short circuits (Chapter 43)
- voltage disturbances, such as lightning strikes, and electromagnetic interference (Chapter 44).

An assessment of the risks associated with each of the above will lead to the need for isolation and switching (Chapter 46).

Chapter 41: Protection Against Electric Shock

Before considering the requirements for protection against electric shock, you will need to recall how an electric shock can be received.

INDUSTRY TIP

Part 4 of BS 7671 can be thought of as a giant electrical risk assessment.

Defining 'electricity'

Revise your basic understanding of what electricity is.

- **Voltage** is the pressure that pushes current around a circuit (and into the human body).
- **Current** is the quantity of electricity that makes things happen (such as muscle reaction).
- **Resistance** is the opposition against the current flow. Resistance also causes voltage loss in circuits or across loads.

Consider this. If you tested the insulation resistance of a shoe, worn by someone standing on a wooden floor, to the electrical earth using an insulation resistance tester set to 250 V, what would be the expected resistance? It would probably be above 200 MΩ (which is 200 000 000 Ω). So, applying Ohm's law:

$$\frac{250}{200\,000\,000} = 1.25 \times 10^{-6} \text{ A or } 1.25 \mu\text{A or } 0.000\,001\,25 \text{ A}$$

HEALTH AND SAFETY

Probably not – there is still a risk, so do **not**, under any circumstances, try this.

Ask yourself, if the person wearing the shoe touched, with their hand, a live part, would that current be enough to cause a serious electric shock? **Probably not** but the person may feel it and know that they are in contact with electricity.

Imagine if that same person was also touching something in contact with earth or standing on the Earth (with one leg). The resistance would fall, and electric shock could occur if currents were to exceed 1 mA – and certainly if current were around 40 mA.

If that same person had another point of contact with earth, say, both feet, body resistance would drop by half because there are now two paths in parallel. If resistance lowers by half, then current, with a fixed voltage of 230 V, will double.

Current has to enter the body to cause electric shock. Skin offers some resistance, and it has been calculated that an **average person** can touch, in **average conditions**, voltages up to 50 V AC or 120 V DC with a vastly reduced risk of electric shock.

While focusing on electric shock, another scenario to consider is someone coming into contact with two live parts from the same circuit or supply phase.

If someone was insulated from earth but came into contact with two line conductors, one in each hand, what would be the pressure (voltage) at each hand? 230 V. And if the line conductors were on the same phase and you put a voltmeter between them, what would the meter read? 0 V; this is because the line conductors are of equal voltage or equipotential. So, if the voltage is 0 V, can current flow? The answer is no, so no electric shock is received.

Protection against electric shock

When protecting against electric shock, it is necessary to consider:

- **basic protection** – stopping contact with parts that are supposed to be live
- **fault protection** – reducing the risk through contact with parts made live during a fault to earth or stopping those parts from becoming live.

KEY TERMS

Average person: The mean between two extremes. As an example, some people have fairer skin than others, so their safe voltage level will be lower; whereas someone who works with hand tools has tougher skin on their hands, so has a higher resistance.

Average conditions: Not too much heat and not too humid. Humidity causes sweat, and sweat causes the pores of the skin to open, reducing resistance and increasing the risk of electric shock. The humid environment of bathrooms is why they are classed as special locations.

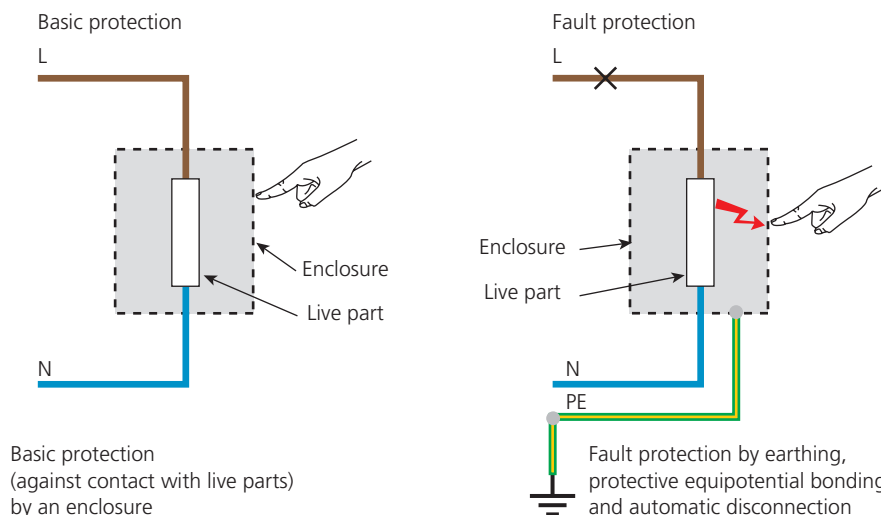

Basic protection
(against contact with live parts)
by an enclosure

▲ Figure 3.7a Basic protection (against contact with live parts) by an enclosure

▲ Figure 3.7b Fault protection by earthing, protective equipotential bonding and automatic disconnection

Protective measures against faults are given in Sections 411 to 414 in BS 7671 and basic protection in Section 416 and, with restriction for use, Section 417. Section 415 gives requirements where additional protection may be required in each case.

Section 411

The protective measure automatic disconnection of supply (ADS) is the most commonly used protective measure in electrical installations. It requires:

- basic protection provided by insulation of live parts or by barriers or enclosures
- fault protection provided by:
 - earthing
 - protective equipotential bonding
 - automatic disconnection in case of a fault.

Subsection 411.3 states that protective earthing is required in all circuits (circuit protective conductor; cpc) and connected to all **exposed conductive parts**. This is essential to ensure that everything is connected to the earth fault loop path by the lowest resistance *possible* and **practical**.

Subsection 411.3 also states that protective equipotential bonding is required for each building. This is done by connecting a main protective bonding conductor complying with Chapter 54 (Part 5: Selection and Erection, so therefore the size) to **extraneous conductive parts** of the installation liable to introduce a potential (voltage) difference as listed in regulation 411.3.1.2. The bonding of metal gas or water pipes in an installation is not needed if the incoming service pipe is insulated.

Earthing and bonding

Even though earthing and bonding, as types of protective conductors, are wired using the same green and yellow cable, their purpose is very different.

KEY TERMS

Protective measures: The methods used to protect against faults, with the most common being automatic disconnection of supply (ADS).

Exposed conductive parts: Parts of the electrical system that can easily be touched and have live parts within, such as metal cases housing wiring systems.

Extraneous conductive parts: Parts that are not part of the electrical system but which may provide a path to earth, such as metal water pipes or the steel supports of a building.

INDUSTRY TIP

Though *possible* to run a big 25 mm² circuit protective conductor to a light, it would not be **practical**.

Earthing is intended to carry a fault current and form part of the overall earth fault loop path. It should have a low enough resistance to ensure that a high enough fault current occurs, to aid quick disconnection of protective devices.

Bonding is intended to transfer a voltage and not necessarily carry fault current. By bonding a metallic gas pipe to the electrical installation earth, should something electrical become faulty and therefore live to 230 V, so too should the gas pipe, equalising the voltage. So, the potential difference between earthed parts and bonded parts is as near to 0 V as possible (equipotential).

Amendment 2 of BS 7671: 2018 (2022) is now worded to imply that main protective bonding is required for every building supplied by a single electrical installation or, in the case of a block of flats, every electrical installation within a building.

INDUSTRY TIP

Single-phase 230 V circuits and three-phase 400 V circuits both have a U_0 of 230 V.

INDUSTRY TIP

A note under Table 41.1 in **BS 7671** indicates that disconnection as TN is permitted for a TT installation where everything is bonded in accordance with 411.3.1.2 and suitable circuit protection is provided, such as a domestic farmhouse.

Disconnection times

Also contained in subsection 411.3 are the required disconnection times in the case of a fault to earth.

Table 41.1 in BS 7671: 2018 (2022) applies to:

- final circuits with a rated current not exceeding 63 A with one or more socket outlets, or
- final circuits with a rated current not exceeding 32 A supplying fixed connected equipment.

It states that for circuits on a system supplied with a nominal voltage to earth (U_0) of 230 V, disconnection must occur within, depending on the earthing arrangement:

- TT – 0.2 seconds
- TN – 0.4 seconds.

Any circuit not covered by Table 41.1, and any distribution circuit, must disconnect within:

- five seconds, in the case of a TN system
- one second, in the case of a TT system.

Additional requirements

In addition to the stated disconnection times, some circuits require additional protection by means of a residual current device (RCD). The reason for this is because of the risk of damage to the basic protection, such as insulation.

Additional protection by means of an RCD with a rated current not exceeding 30 mA must be provided in the following situations:

- socket outlets with a rated current not exceeding 32 A and used by Ordinary Persons or children
- socket outlets with a rating up to 32 A with restricted use
- mobile equipment with a rated current not exceeding 32 A used outdoors
- circuits supplying luminaires within domestic installations.

In these situations, there is a greater risk of damage to the insulation. For example:

- appliances plugged into socket outlets may be poorly maintained and have damaged insulation
- extension leads are more prone to damage when supplying lawnmowers and similar equipment
- damage to insulation in tight metallic housings from heat produced by lamps, such as decorative metal luminaires.

In the case of socket outlets having restricted use, RCD protection may be omitted, providing a documented risk assessment shows that the equipment used is maintained correctly, restricted and the users are trained to understand the risks, i.e. they are not Ordinary Persons as defined in EWR.

TN systems

TN systems have a reliable connection to earth and therefore a reliable earth fault loop path.

This means that TN systems, if designed correctly, have a suitable total earth fault loop impedance low enough to cause disconnection of the protective device. How low this earth fault loop impedance needs to be will depend on the type of device and the required disconnection time.

INDUSTRY TIP

Where a documented risk assessment is needed due to the removal of additional protection by an RCD, see Appendix 2, item 11 of BS 7671 for additional information.

The risk assessment should look at reducing the risk by:

- training users about the risk and the need for user checks
- risk assessing the equipment for suitability for use and environment which should be documented on an asset register
- having a policy that only equipment listed on an asset register may be used
- equipment undergoes regular maintenance such as in-service inspection and testing.

IMPROVE YOUR MATHS

Remember, the total earth fault loop impedance (Z_s) is calculated by:

$$Z_s = Z_e + (R_1 + R_2)$$

Where:

- Z_e is the external earth fault loop impedance
- R_1 is the resistance of the line conductor within the installation
- R_2 is the resistance of the circuit protective conductor (cpc) in the installation.

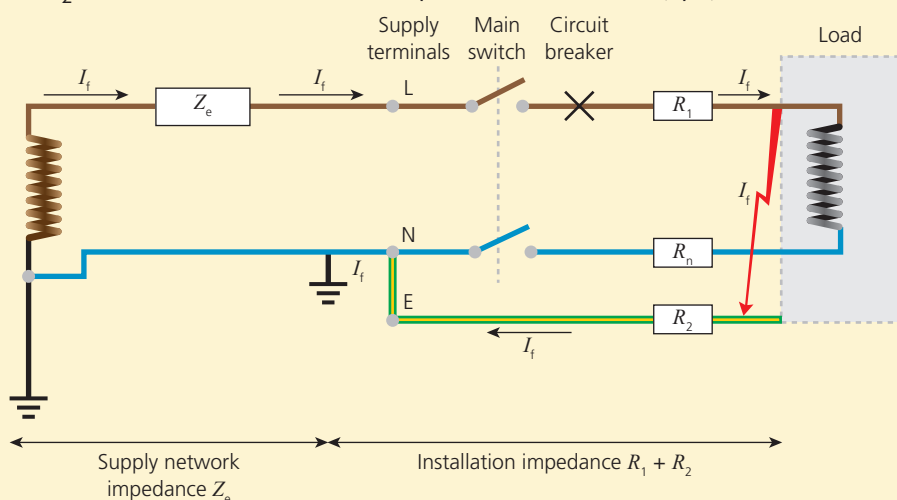

Figure 3.8 Fault current (I_f) path in a TN-C-S system

INDUSTRY TIP

Note that the values in Tables 41.2–41.4 of BS 7671 are for design purposes where operating temperatures of the circuits have been considered.

If using these tables to compare measured values of Z_s , adjustments should be made to the values in the tables, and any measured value should not exceed 80% of the values in the tables.

INDUSTRY TIP

Remember this figure of 50 V from earlier? It is the safe touch voltage in the case of AC.

To determine the maximum permitted values of Z_s , the following tables in BS 7671: 2018 are used.

- Table 41.2 is for circuits that are protected by fuses and which require a disconnection time within 0.4 seconds.
- Table 41.3 is for circuits that are protected by circuit breakers or residual current breakers with overload (RCBOs) whatever the required disconnection time.
- Table 41.4 is for circuits that are protected by fuses and which require a disconnection time within five seconds.

As long as the designed and verified earth fault loop impedance values are within the values in the tables, disconnection will take place within the required time.

In some situations where the earth fault loop impedance is too high to meet the values in the tables, Regulation 411.4.204 permits the use of an RCD, allowing values of Z_s to comply with Table 41.5 instead, which has much higher permitted values. However, questions should be asked as to why the Z_s is too high and whether the circuit is adequately short-circuit protected (see Chapter 43 of BS 7671: 2018 (2022)).

TT systems

As TT systems rely on the general mass of earth as part of their earth return path, earth fault loop impedance values may be too high to meet the values in Tables 41.2–41.4 so, instead, RCD protection is preferred for these installations.

In some situations where values of earth fault loop impedance are above 200 Ω or, when the value may be far too high to even read with an earth fault loop impedance test instrument, the earth electrode resistance is measured, and this is known as R_A .

Aided by Table 41.5 in BS 7671, the value of R_A or Z_s is used to determine the suitable rating of RCD for protecting a TT system. The purpose of Table 41.5 is to ensure that in the case of a fault, the RCD trips, based on the earth electrode resistance, before the voltage on any earthing rises above 50 V.

So, for an example using Table 41.5, if an earth electrode had a resistance of 125 Ω , this resistance is above 100 Ω but below 167 Ω , so a 300 mA RCD would provide the protection needed.

Reduced low-voltage systems

Subsection 411.8 deals with the requirements for automatic disconnection of supply on 110 V site supply systems and the need for disconnection time to be within five seconds. To achieve this, values of earth fault loop impedance should not exceed those in Table 41.6.

Section 412

This section provides detail where the protective measure against faults is double or reinforced insulation. The way this protects against shock is by having a basic layer of insulation and a further layer of insulation, which should prevent faults occurring.

Only **Class II equipment** is permitted for this protective measure and double or reinforced insulation can only be used where the installation is under effective supervision by skilled persons. More detail on the restrictions that apply are found in Regulation 412.2.

Because of the way Class II equipment is constructed, the only possible way it can become faulty is through misuse or abuse.

Section 413

Section 413 deals with the requirements for electrical separation as a method of fault protection. The most common form of electrical separation found on electrical installations is a shaver socket in a bathroom. The system is normally limited to the supply of one item of equipment as more than one item reduces the level of fault protection.

Electrical separation works by using an isolating transformer to create a secondary circuit that is completely independent of the supply circuit and earth. So, should a fault occur, current would not flow to earth as the earth is not part of the circuit. Current is drawn back to the point where it was induced – in this case, the isolating transformer. As earth is not part of that circuit, current will not be drawn to earth or through a person as neither provides a path back.

Electrical separation circuits operate at voltages between 50 V and 500 V AC.

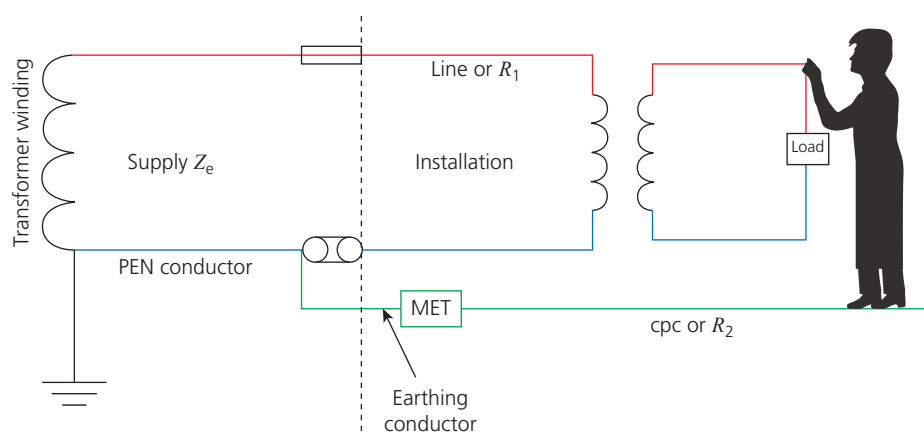

▲ Figure 3.9 Electrical separation means current cannot flow to earth as the earth is not part of the system

Section 414

Section 414 covers the requirements for **separated extra-low voltage (SELV)** and **protective extra-low voltage (PELV)**. These systems operate at voltages below 50 V AC and are separated, as described above. This means that current will not flow through a person in the event of a fault, nor can current flow as the voltage is less than 50 V.

KEY TERM

Class II equipment: Double insulated or reinforced insulated equipment, having the symbol



HEALTH AND SAFETY

Electricians, from time to time and while working on very old installations, come across lighting circuits without earthing. These circuits were installed as double-insulated circuits because all the equipment used on them was Class II. Lighting circuits without earthing are no longer permitted because metal light fittings or switches are a popular choice among consumers. It can be very dangerous if these metal fittings or switches are installed without earthing.

KEY TERMS

Separated extra-low voltage (SELV): The same as electrical separation but the voltage is extra low (< 50 V AC).

Protective extra-low voltage (PELV): Operates at extra-low voltage but may have a connection to earth.

Section 415

This section deals with the requirements where additional protection is needed.

Additional protection may be in addition to basic protection, in the case of an RCD, or by supplementary equipotential bonding, in the case of fault protection.

Where an RCD is required for additional protection, the rated residual current of the device should not exceed 30 mA.

In less common situations, where disconnection times cannot be met and the use of an RCD would not be suitable due to the risk of nuisance tripping, supplementary bonding is applied. This is installed to ensure that equal voltages (equipotential) exist between the equipment under fault and any extraneous parts within touching distance.

Section 416

Section 416 deals with the requirements for basic protection, achieved through:

- basic insulation; or
- barriers and enclosures.

Basic insulation

Regulation 416.1 states that live parts shall be completely covered with insulation that can only be removed by destruction. However, not all insulating materials are suitable for providing basic protection. Varnish and lacquer, for example, perform an insulating function when used on windings, but Regulation 416.1 states:

‘Paint, varnish, lacquer or similar products are generally not considered to provide adequate insulation for basic protection in normal service.’

Barriers and enclosures

Not all live parts can be covered in insulation because they may need to move or be terminated. The easier option, therefore, is to put live parts that may need to move or be terminated, inside a box; that is, an enclosure.

When an enclosure is used, it is important to ensure that any holes in the enclosure do not present a risk from electric shock. Regulation 416.2.1 states that holes in the enclosure should meet the minimum requirements of IPXXB or IP2X. This means that no hole or opening in the enclosure can be larger than 12 mm in diameter when the enclosure is in normal use. IPXXB takes the requirements a little bit further, as this IP code states that protection must be against an object that is not only to be smaller than 12 mm in diameter but also up to 80 mm long, with two 90° joints.

Table 3.3 explains all the IP codes that you may come across when working on electrical systems and equipment.

INDUSTRY TIP

An IP code gives the level of ingress protection that a barrier or enclosure provides.

▼ Table 3.3 IP codes explained

First characteristic numeral		Second characteristic numeral	
(a) Protection of persons against access to hazardous parts inside enclosures (b) Protection of equipment against entry of solid foreign objects		Protection of equipment against ingress of water	
No.	Degree of protection	No.	Degree of protection
0	(a) No protection (b) No protection	0	No protection
1	(a) Protection against access to hazardous parts with the back of the hand (b) Protection against the entry of foreign solid objects 50 mm in diameter or more	1	Protection against vertically falling water drops
2	(a) Protection against access to hazardous parts with a finger (b) Protection against the entry of solid foreign objects 12.5 mm in diameter or more	2	Protection against vertically falling water drops when the enclosure is tilted up to 15° from vertical
3	(a) Protection against entry by tools, wires, and so on, 2.5 mm in diameter or more (b) Protection against entry by solid foreign objects 2.5 mm in diameter or more	3	Protection against water spraying at any angle up to 60° on either side of the vertical
4	(a) As 3 above but against entry with a wire or strips 1.0 mm thick or more (b) Protection against the entry of solid foreign objects 1.0 mm in diameter or more	4	Protection against splashes of water from any direction
Additional letter	Brief description of protection		
A	Protection against access with the back of the hand (minimum 50 mm diameter sphere) (adequate clearance from live parts)		
B	Protection against access with a finger (minimum 12 mm diameter test finger, 80 mm long) (adequate clearance from live parts)		
C	Protection against access with a tool (minimum 2.5 mm diameter tool, 100 mm long) (adequate clearance from live parts)		
D	Protection against access with a wire (minimum 1 mm diameter wire, 100 mm long) (adequate clearance from live parts)		

Source: Guidance Note 1: Selection and Erection of Equipment, IET

When the enclosure is mounted in a position where the top is accessible, then BS 7671 increases the level of protection required. Regulation 416.2.2 states that accessible top surfaces of enclosures need to be to IPXXD or IP4X. This higher level of IP code means that items measuring 1 mm in diameter or more will not be able to enter the opening. The IPXXD code means that an object 1 mm in diameter that is 100 mm long should not come into contact with live parts. Where an internal barrier is to be used, then this must comply with the IP codes of IPXXB or IP2X.

Removal of a barrier must only be achieved by using a key or tool, or by destruction.

Section 417

Obstacles

Unlike basic insulation, barriers or enclosures, the sole use of obstacles as a means of basic protection is only permitted in installations that are controlled or supervised by a competent or skilled person. The note under the heading of Section 417.2 in BS 7671 says that the purpose of obstacles is to prevent unintentional contact with live parts, but obstacles are not intended to prevent deliberate actions to cause contact with live parts.

Obstacles can be removed without the need to use a key or tool or destruction. There is also no specification as to the level of IP rating that is required, as penetration of the obstacle would be a deliberate act performed with the intention of touching something live.

Placing out of reach

As with obstacles, the protective measure of placing out of reach can only be used when the circuits are under the control or supervision of a competent or skilled person. Placing out of reach is intended to prevent accidental contact with live parts by moving them out of the way. However, as people are different heights and sizes, Regulation 417.3.1 states a standard distance above which a live part is deemed to be out of reach. The standard distance is more than 2.5 m between simultaneously accessible parts.

KEY TERM

Arc fault detection devices (AFDD): Devices that detect variations in the current sine wave, which are common when loose terminals cause arcing. If these devices detect the signature of an arc, they disconnect the circuit in question.

Chapter 42: Protection Against Thermal Effects

Chapter 42 of BS 7671 describes measures to protect against ignition or the effects of heat, fire, smoke or thermal radiation.

Section 421

Section 421 gives general requirements for all installations and many requirements relating to the risk of fire caused by electrical equipment or the spread of fire from burning liquids that may escape from electrical equipment.

It also states that consumer units in domestic installations require a metallic enclosure, or to be mounted within a metallic enclosure, to stop the spread of fire. A consumer unit can be a major source of fire, owing to the potential for loose connections and the unit's role in powering all the circuits in a domestic dwelling. These two factors combined demonstrate the high risk that a consumer unit presents if not maintained properly.

Regulation 421.1.7 states that **arc fault detection devices (AFDD)** must be installed at the origin of all single-phase, final circuits rated up to 32 A supplying socket outlets within specifically listed **residential premises**. For other circuits, they are recommended. They should be omitted where sudden disconnection will cause a danger, such as lighting circuits in dwellings.

KEY FACTS

Residential Premises where AFDDs need to be installed include:

- high-risk residential buildings (over 18 m in height or more than 6 floors)
- houses of multiple occupation (HMO)
- purpose-built student accommodation
- care homes.

Section 422

This section of BS 7671 covers:

- electrical installations in protected escape routes
- installations with a higher risk of fire owing to the storage or production of combustible material.

The risk with escape routes is where electrical equipment encroaches onto the route causing trip, snag or smoke issues.

In locations where there is a fire risk due to the nature of stored and manufactured material, only certain wiring systems can be used. Examples of such locations are paper mills, woodwork factories and hay barns. Electrical equipment must be adequately spaced from the stored and manufactured material, to reduce the risk of the equipment catching fire.



▲ Figure 3.10 A paper mill is a location where a risk of fire exists

Section 422 also includes regulations relating to electrical equipment that is installed in buildings made of combustible material, such as wooden sheds, and buildings of public significance, such as museums.

Section 423

This section covers protection against burns. Table 42.1 in BS 7671 gives maximum acceptable temperatures for accessible parts of electrical equipment.

Chapter 43: Overcurrent Protection

Chapter 43 relates to protection against **overcurrent**.

Overcurrent may result from:

- overload
- fault current.

HEALTH AND SAFETY

Consider many people trying to escape along a long corridor that has a socket outlet, with an appliance plugged in, positioned in the escape route. The socket outlet creates a potential trip hazard. If it is not needed, do not put it in!

KEY TERM

Overcurrent: More current in a circuit than is intended.

Before exploring fault current in detail, it is useful to revise overcurrent protective devices.

Overcurrent protective devices

Overcurrent protective devices may be one or a combination of:

- fuses
- circuit breakers
- residual current devices (RCD)
- residual current breakers with overload (RCBO).

KEY TERM

Blown: In the context of fuses, when the element in the fuse has melted or ruptured due to excessive current.

Fuses

Fuses have been a tried and tested method of circuit protection for many years. A fuse is a very basic protection device that melts and breaks the circuit should the current exceed the rating of the fuse. Once the fuse has **blown**, it needs to be replaced.

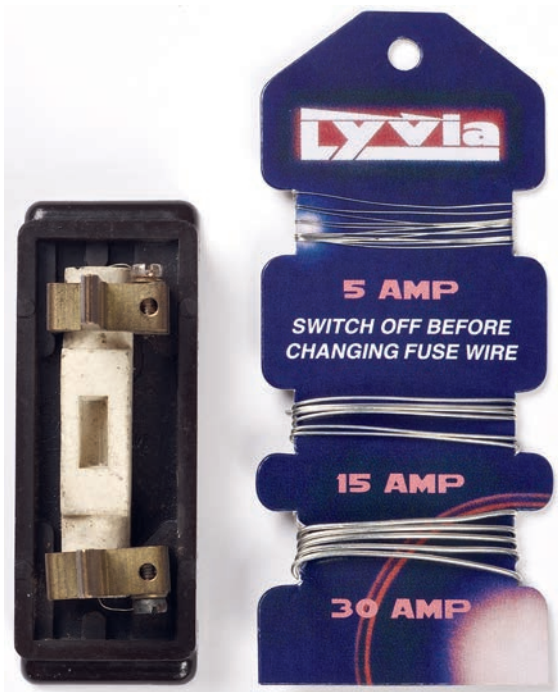

▲ Figure 3.11 Rewirable fuse and fuse wire card, showing how wrong wire can easily be used

Fuses have several ratings.

- I_n is the nominal current rating. This is the current that the fuse can carry, without disconnection, without reducing the expected life of the fuse.
- I_a is the disconnection current rating. This is the value of current that will cause the disconnection of the fuse in a given time.
- Breaking capacity (kA) rating is the current up to which the fuse can safely disconnect fault currents. Any fault current above this rating may cause the fuse and carrier to explode.

BS 3036 rewirable fuses

In older equipment, the fuse may be just a length of appropriate fuse wire fixed between two terminals. There are increasingly fewer of these devices around as electrical installations are rewired or updated.

One of the main problems associated with rewirable fuses is the overall lack of protection, including insufficient breaking capacity ratings. Another major problem is that the incorrect rating of wire can easily be inserted when changing the fuse, leaving the circuit underprotected.

KEY TERM

Selectivity: Ensuring that the lower rated protective device nearest the fault disconnects first. If another device disconnects which protects a collection of circuits, this would lead to disruption.

BS 88 fuses

These modern fuses are generally incorporated into sealed cylindrical ceramic bodies (or cartridges). If the element inside blows, the whole cartridge needs to be replaced. Although these devices have fixed time–current curves, they can be configured to assist **selectivity**.

The benefit of **BS 88** fuses, and similar fuses, is their simplicity and reliability, coupled with high short-circuit breaking capacity.

Within some types of BS 88 fuse, usually the bolted type, there may be more than one element. The purpose of this is to minimise the energy from a single explosion, should the fuse be subjected to high fault currents. Instead there will be several smaller explosions, allowing these devices to handle much higher fault currents of up to 80 kA.

Other BS 88 devices may be the clipped type, which do not have the two bolt tags. They are simply barrel shaped and slot into place in the carrier. They are often called cartridge fuses.

Another type of cartridge fuse is the **BS 1362** plug fuse. This fuse is fitted into 13 A plugs and is available in a range of ratings. Typical ratings are 3 A, 5 A and 13 A.

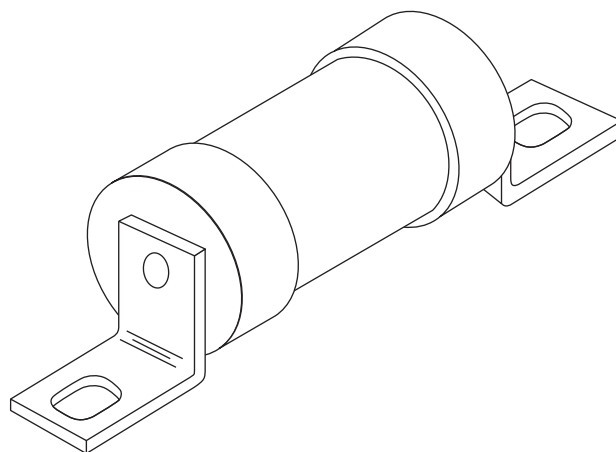

▲ Figure 3.12 **BS 88** bolted-type fuse

Circuit breakers

Circuit breakers (CBs) have several ratings.

- I_n is the nominal current rating. This is the current that the device can carry without disconnection, and without reducing the expected life of the device.
- I_a is the disconnection current. This is the value of current that will cause the disconnection of the device in a given time.
- I_{cn} is the value of fault current above which there is a danger of the device exploding or, worse, welding the contacts together.
- I_{cs} is the value of fault current that the device can handle and remain serviceable.

Circuit breakers are thermomagnetic devices capable of making, carrying and interrupting currents under normal and abnormal conditions. They fall into two categories:

- miniature circuit breakers (MCBs), which are common in most installations for the protection of final circuits
- moulded-case circuit breakers (MCCBs), which are normally used for larger distribution circuits.

Both types work on the same principle. They have a magnetic trip and an overload trip, which is usually a bimetallic strip. If a CB is subjected to overload current, the bimetallic strip bends due to the heating effect of the overcurrent. The bent strip eventually trips the switch, although this can take considerable time, depending on the level of overload.

Miniature circuit breakers

These thermomagnetic devices have different characteristics depending on their manufacture. They generally have a lower prospective short-circuit current rating than a high-rupturing capacity (HRC) fuse, ranging from approximately 6 kA to 10 kA. Specialist units are available for higher values.

The operating characteristics of MCBs can be shown in graphical form by a time–current curve.

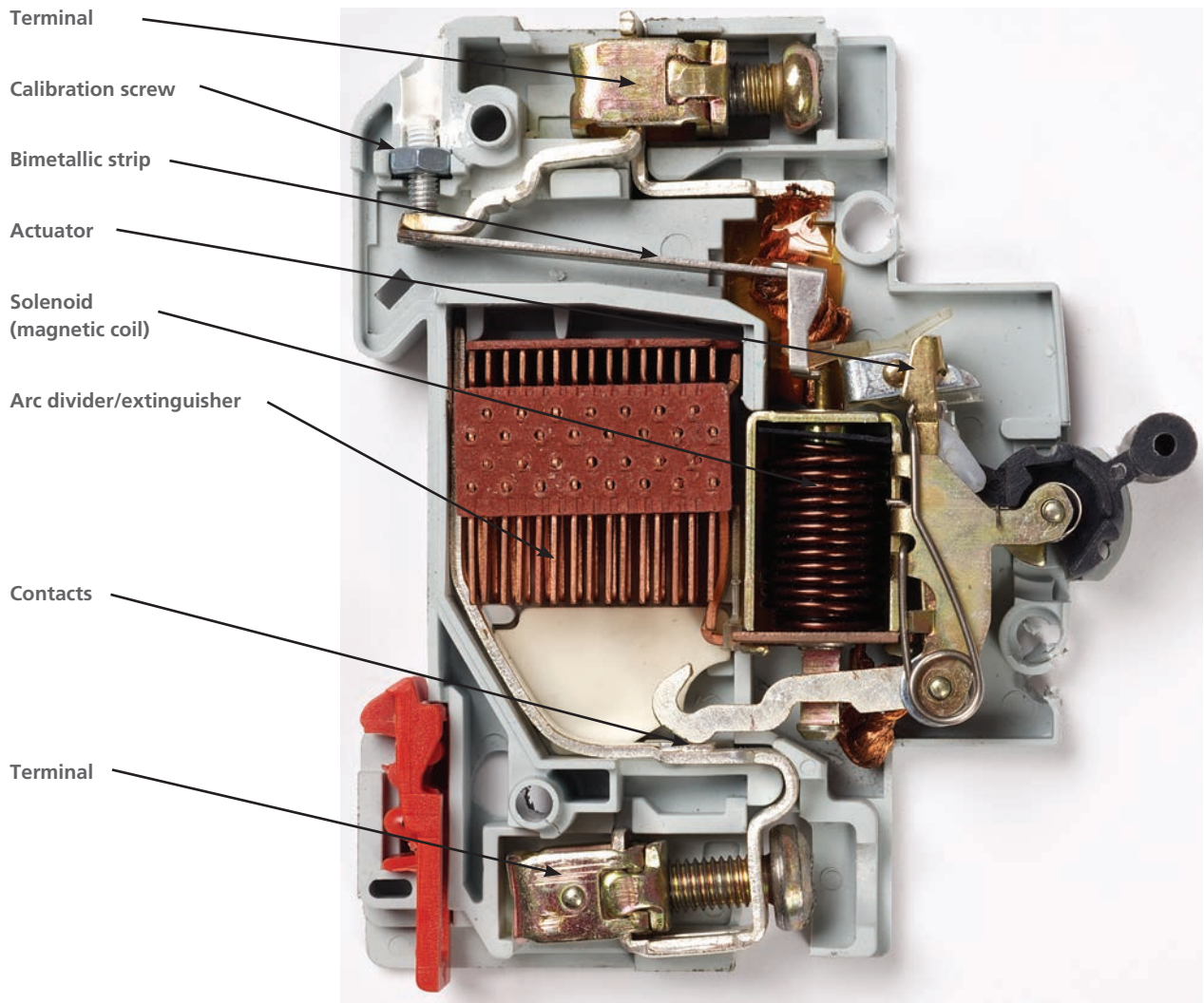

▲ Figure 3.13 Section through a circuit breaker

Miniature circuit breakers are generally faster acting than the standard curve in BS 88 fuses. A CB has a curve, then a straight line, whereas the BS 88 fuse is fully curved. This demonstrates the two tripping mechanisms in a CB. The magnetic trip is represented by the straight line on the graph, indicating that a predetermined value of fault current will disconnect the device rapidly.

The curve represents the device's thermal mechanism. Like a fuse, the thermal mechanism reacts within a time specific to the overload current. The bigger the overload, the faster the reaction.

Moulded-case circuit breakers

Although moulded-case circuit breakers work on the same principle as MCBs, the moulded-case construction and physical size of MCCBs gives them much higher breaking capacity ratings than those of MCBs. Many MCCBs have adjustable current settings.

Residual current devices and residual current circuit breakers with overload

Residual current devices (RCDs) operate by monitoring the current in both the line and neutral conductors of a circuit. If the circuit is healthy with no earth faults, the toroidal core inside the device remains balanced with no magnetic flux flow. If a residual earth fault occurs in the circuit, slightly more current flows in the line conductor compared with the neutral. If this imbalance exceeds the residual current setting of the device, the flux flowing in the core is sensed by the sensing coil, which induces a current to a solenoid, tripping the device.

Residual current breakers with overload (RCBOs) combine an overcurrent protective device with an RCD in the body of the CB.

Unlike CBs, both RCDs and RCBOs have a test button, which should be pressed at regular intervals to keep the mechanical parts working effectively. If the mechanical components in a CB stick, there is not much cause for concern as the energy needed to trip a CB is large enough to free any seized parts. As RCDs and RCBOs operate under earth fault conditions with relatively small residual currents, there may not be enough energy to free any seized parts.

Application of protective devices

BS 3036 rewirable fuses

Unlike most other protective devices, the **BS 3036** fuse arrangement does not have a very accurate operating time or current as it is dependent upon factors such as age, level of oxidation on the element and how the arrangement has been installed (e.g. whether it was badly tightened, open to air movement).

The lack of reliability of these fuses is a concern to designers and duty holders. Due to the lack of sensitivity, special factors have been applied to Appendix 4 of BS 7671 to account for these fuses. The rating factor to be applied (C_f) is 0.725.

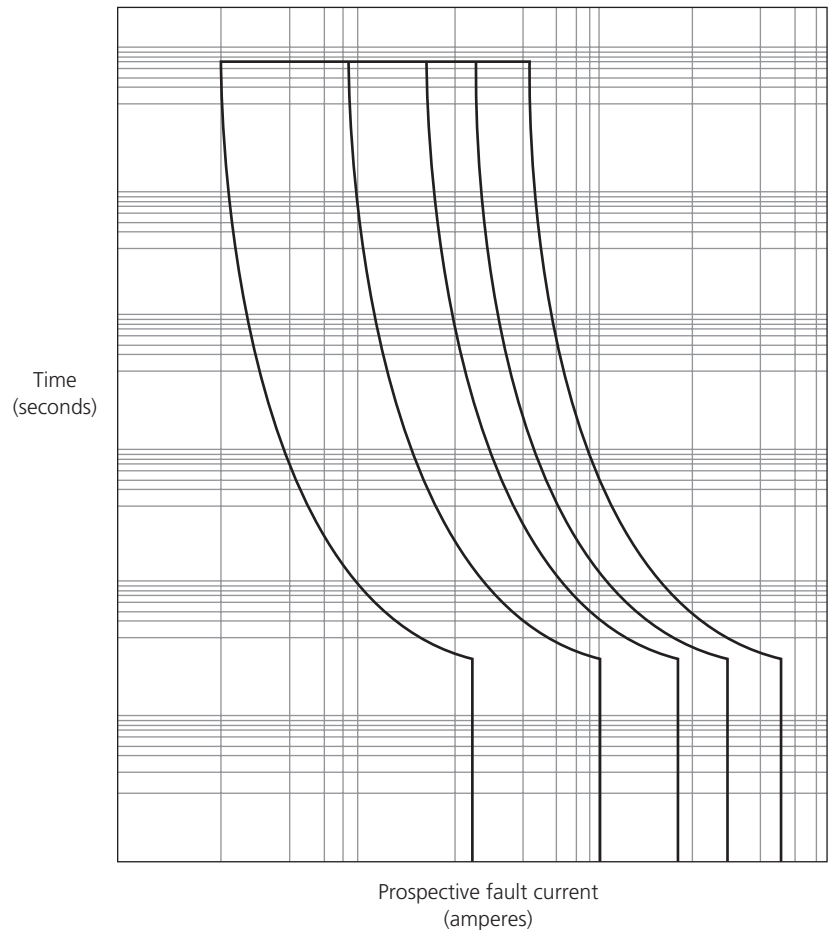

▲ Figure 3.14 Sample time–current characteristic graph

Source: Appendix 3, BS 7671: 2018 (2022) The IET Wiring Regulations, 18th Edition, IET

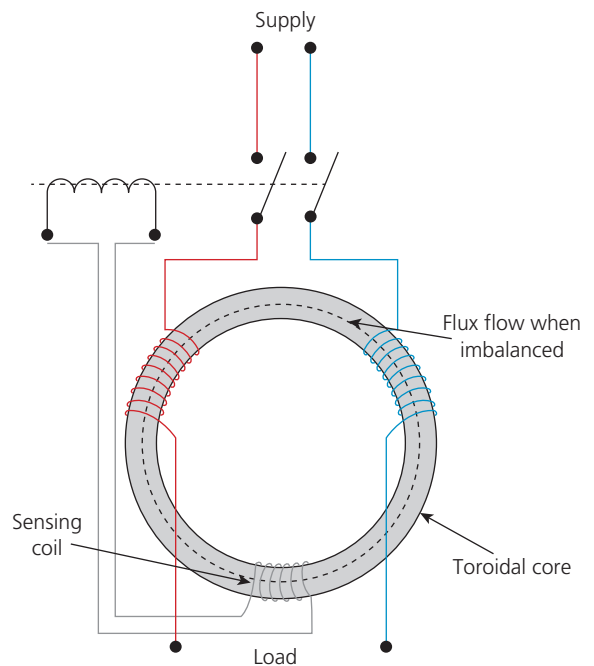

▲ Figure 3.15 Internal circuit diagram for an RCD



▲ Figure 3.16 A range of BS 3036 rewirable fuses: 5 A (white), 15 A (blue) and 20 A (red)

BS 88 fuses

High-rupturing capacity (HRC) or high-breaking capacity (HBC) fuses are common in many industrial installations. They are also very common in switch fuses or fused switches controlling specific items of equipment. They are particularly suited to installations with a high prospective fault current (I_{pf}) as they have breaking capacities of up to 80 kA.

BS 88 fuses come in two categories:

- gG for general circuit applications, where high inrush currents are not expected
- gM for motor-rated circuits or similar, where high inrush currents are expected.

Miniature circuit breakers

There are three common types of MCB; the difference between the devices is the value of current (I_a) at which the magnetic part of the device trips. The different types are selected to suit loads where particular inrush currents are expected.

Type B MCBs trip between three and five times the rated current (3 to $5 \times I_n$). These MCBs are normally used for domestic circuits and commercial applications where there is no inrush current to cause them to trip. For example, the magnetic tripping current in a 32 A Type B CB could be 160 A, so $I_a = 5 \times I_n$. These MCBs are used where maximum protection is required and therefore should be the choice for general socket-outlet applications.

Type C MCBs trip between five and ten times the rated current (5 to $10 \times I_n$). These MCBs are normally used for commercial applications where there are small to medium motors or fluorescent luminaires and where there is some inrush current that would cause the CB to trip. For example, the magnetic tripping current in a 32 A Type C CB could be 320 A, so $I_a = 10 \times I_n$.

Type D MCBs trip between ten and twenty times the rated current (10 to $20 \times I_n$). These MCBs are for specific industrial applications where there are large inrushes of current for industrial motors, X-ray units, welding equipment, etc. For example, the magnetic trip in a 32 A Type D CB could be 640 A, so $I_a = 20 \times I_n$.

Moulded-case circuit breakers

Moulded-case circuit breakers are available in various ranges. Lower-cost, simpler versions are thermomagnetic with no adjustment. Other devices have electronic trip units and sensitivity settings or the ability to be de-rated.

Most MCCBs are used on larger circuits or distribution circuits where larger prospective short circuits are likely but the flexibility of an electronic trip is also required.

Short-circuit breaking capacities

One of the greatest considerations when selecting a protective device for any installation is the suitability of the device to disconnect a fault current safely. If a fault current exceeds the breaking capacity of a protective device, the device may:

- explode, causing a risk of fire or burns
- damage the internal components, making the device inoperable in the case of CBs
- weld contacts together, so the device will not interrupt the fault current.

It is essential that designers of electrical installations select protective devices that have a rated short-circuit capacity or breaking capacity greater than the prospective fault current (I_{pf}) for that part of the electrical installation.

Table 3.4 shows the rated short-circuit capacities of commonly used protective devices.

▼ Table 3.4 Rated short-circuit capacities of protective devices

Device type	Device designation	Rated short-circuit capacity (kA)	
Semi-enclosed fuse to BS 3036 with category of duty	S1A	1	
	S2A	2	
	S4A	4	
BS 88-3		16	
		31.5	
General purpose fuse to BS 88-6		16.5 at 240 V 80 at 415 V	
Circuit breakers to BS 3871 (replaced by BS EN 60898)	M1	1	
	M1.5	1.5	
	M3	3	
	M4.5	4.5	
	M6	6	
	M9	9	
Circuit breakers to BS EN 60898* and residual current breakers with overload (RCBOs) to BS EN 61009		I_{cn}	I_{cs}
		1.5	(1.5)
		3.0	(3.0)
		6	(6.0)
		10	(7.5)
		15	(7.5)
		20	(10.0)
	25	(12.5)	

* Two short-circuit capacities are defined in BS EN 60898 and BS EN 61009: I_{cn} is the rated short-circuit capacity (marked on the device) and I_{cs} is the in-service short-circuit capacity.

Source: On-Site Guide, IET

KEY TERMS

Short circuits: When a fault occurs between live conductors. The fault could be between line and neutral or, in the case of a three-phase circuit, line to line.

If an installation has been correctly designed and a circuit disconnects within the required time because the earth fault loop impedances meet those in Tables 41.2–41.4 of BS 7671, it could be considered that a circuit will also disconnect safely under short-circuit conditions.

There is no specified disconnection time for short circuits but the protective device must disconnect before the cable reaches its final temperature; that is, the temperature at which the insulation is melting and the cable is no longer adequate. If a short circuit were allowed to continue, the heat could also cause a fire.

A cable's **final temperature** is the point at which the weakest part of the cable, usually the insulation, melts.

Overcurrent

You have already been introduced to overcurrent and examined the types of overcurrent devices. You will now explore in detail two forms of overcurrent. These are overload current and fault current.

Overload current

Overloads are not as common as you may think. If an installation has been designed correctly, only a few circuits may be liable to overload.

When you consider that most appliances are becoming more efficient – consuming much less current – circuits, such as traditional 32 A ring-final circuits for the upstairs of a house, will probably only be subjected to one or two amperes at any given time. For a short duration, a hairdryer may be used for approximately one minute each time, but it may only typically draw three or four amperes.

A circuit for which an overload may need to be designed could be located somewhere such as a conference room, which has multiple socket outlets for small power laptops or phone chargers. If, however, the heating broke down, the management team could bring in heaters and plug them into the circuit, potentially overloading it.

Fault current

Fault current comes in two forms: earth fault current and **short circuits**.

IMPROVE YOUR MATHS



Calculating disconnection time for short circuits

The following formula is used to calculate a suitable disconnection time for short circuits: $t = \frac{S^2 K^2}{I^2}$ in seconds

Where:

- S is the cross-sectional area (csa) of the circuit live conductors, in mm^2
- K is the factor for the cable insulation, which is taken from Table 43.1 in BS 7671
- I is the short-circuit fault current based on the total impedance
- t is the time, in seconds, the cable takes to reach the final limiting temperature.

The intention is to prove that a protective device will disconnect before the time (t) is reached, therefore protecting the circuit from overheating beyond the cable's permitted **final temperature**.

Below are the steps we can take to calculate the disconnection time for short circuits.

Step 1

Determine the circuit $R_1 + R_N$, which is the resistance of the line–neutral loop of the circuit in question. This is done by consulting Tables I1 and I3 from the IET On-Site Guide, using the live conductor cross-sectional area (S in the adiabatic equation).

Step 2

Determine the supply line–neutral loop impedance. This may be done by measurement or calculation or enquiry.

Step 3

Add the supply line–neutral loop impedance to the $R_1 + R_N$ to determine the overall short-circuit impedance, so

$$\text{Total short-circuit impedance} = Z_{\text{supply}} + R_1 + R_N$$

This impedance can then be used to determine the actual short-circuit current I_{psc} using Ohm’s law. This value of current would represent I in the adiabatic equation.

Step 4

From Table 43.1 in BS 7671, find the value of k based on the type of insulation.

Step 5

Using the values obtained, determine the value t using the adiabatic equation.

$$t = \frac{S^2 K^2}{I^2} \text{ in seconds}$$

Step 6

Using Appendix 3 of BS 7671, check how quickly the particular protective device will disconnect, using the current I current characteristic graph for that particular device and rating. Finally, the value t from the equation must be greater than the time taken for disconnection for the circuit to be adequately protected.

IMPROVE YOUR MATHS



Calculating disconnection time for short circuits: example

A 230 V single-phase final circuit is wired using flat-profile 70°C thermoplastic twin and cpc cable with 1.5/1.0 mm² copper conductors to a length of 25 m. The circuit is protected by a 10 A Type C circuit breaker. The supply line–neutral loop impedance is 0.4 Ω.

Determine if the circuit has adequate short-circuit protection.

Step 1

- Determine $R_1 + R_N$ using Tables I1 and I3 in the IET On-Site Guide.
- From Table I1, the resistance for a 1.5/1.5 mm² (live conductors) combination is 24.20 mΩ/m at 20°C. From Table I3, the factor of 1.2 is used as the cable is fully incorporated, so

$$\frac{24.2 \times 25 \times 1.2}{1000} = 0.73 \Omega \text{ at operating temperature } 70^\circ\text{C}$$

Step 2

So, the total short-circuit impedance is

Supply impedance + $R_1 + R_N$, so:

$$0.4 + 0.73 = 1.13 \Omega$$

Step 3

Therefore, the short-circuit current, using Ohm’s law, would be:

$$\frac{230}{1.13} = 203.54 \text{ A}$$

Step 4

From Table 43.1 in BS 7671, the value of k is 115 and, as previously found:

$$I = 203.54 \text{ and } S = 1.5$$

Now use these values in the adiabatic equation:

$$t = \frac{1.5^2 \times 115^2}{203.54^2} = 0.72 \text{ seconds}$$

This means that the cable would take 0.72 seconds to reach a temperature of 160°C and the insulation would begin to melt.

Step 5

Using the graphs in Appendix 3 of BS 7671, the time taken to disconnect a 10 A Type C circuit breaker is < 0.1 seconds.

As the device **trips before the cable melts**, this is a **safe** circuit.

Current coordination

For a circuit to comply with the requirements in Chapter 43 of BS 7671, it must be correctly coordinated. This means that the protective device rating is suitable for the design current and the cable has a current capacity that is suitable for the protective device. In short, a correctly coordinated circuit should meet the following:

$$I_b \leq I_n \leq I_z$$

Where:

- I_b is the circuit design current
- I_n is the rating of the protective device
- I_z is the current-carrying capacity of the conductor based on installed conditions.

If, on a rare occasion, a circuit may be reasonably subjected to overloads, then:

$$I_z \geq 1.45 \times I_n$$

So in a normal circuit where overloads are not expected, the circuit should be coordinated, such as in the following example.

Current coordination: example

If we had a circuit that:

- had a design current of 14 A
- was protected by a 16 A device
- had a circuit cable with a current-carrying capacity, after consideration of the installed conditions, of 24 A,

then this could be expressed as:

$$I_b = 14 \text{ A} < I_n = 16 \text{ A} < I_z = 24 \text{ A}$$

But if that circuit was liable to overloads, then:

$$16 \times 1.45 = 23.2 \text{ A} < 24 \text{ A } I_z$$

In this situation, the circuit would also have capabilities for any potential short-term overloads.

The reason for the 1.45 factor is that most protective devices would not reasonably disconnect at a current less than this. A quick look at Appendix 3 in BS 7671 shows that a 16 A Type B circuit breaker would not disconnect until approximately 23 A is reached. Even then, it would take 10 000 seconds, which is approximately 2 hours 45 minutes.

As long as the cable is capable of this current, it will not overheat.

Short-circuit capacity

In Chapter 43 of BS 7671, Regulation 434.5.1 requires that the rated short-circuit or breaking capacity of each protective device shall not be less than the prospective fault current at that part of the installation.

This regulation is the reason we test prospective fault current during an initial verification and check that the short-circuit capacity of the devices is **suitable** for that fault. We looked at capacities of devices earlier in this section.

Chapter 44: Protection Against Voltage Disturbances and Electromagnetic Interference

Most of Chapter 44 in BS 7671 is devoted to specialist design work. We will look at sections of this chapter that are relevant to most installations and one area specific to broadband and WiFi.

Chapter 44 has four sections:

- Section 442 – Protection of low-voltage installations against temporary overvoltages due to earth faults in the high-voltage system and faults in the low-voltage system
- Section 443 – Protection against overvoltages of atmospheric origin
- Section 444 – Measures against electromagnetic disturbances
- Section 445 – Protection against undervoltages.

Section 442

In this section, BS 7671 provides requirements for the design and installation of substation transformer systems. If you recall coverage of supply and distribution systems from your science studies, some installations are supplied at 33 kV or 11 kV. In these situations, the consumer is responsible for the substation, and Section 442 gives detailed requirements for this.

Section 443

Section 443 gives requirements for installations and networks where a voltage disturbance of atmospheric origin is a risk. In simple terms, that means

KEY TERM

Suitable: In this context means that a device can safely disconnect the fault without blowing up or, in the case of a circuit breaker, having the contacts weld together.

KEY TERMS

Electromagnetic interference (EMI):

The process of electromagnetic radiation interfering with sensitive electronic components. For example, when you turn a light switch on or off, a tiny arc occurs as the switch makes or breaks contact, resulting in electromagnetic interference.

Undervoltage: A reduction or loss of voltage; quite simply, a power cut.

INDUSTRY TIP

If you have a broadband router and you regularly lose your connection, it may be because your router is located close to something that is emitting electromagnetic radiation and interfering with the electronic components inside. This could be a fridge, TV or a fluorescent light. Placing your router in a position away from these sources can stop this.

If you have an FM radio (not DAB) and you switch on a fluorescent light, as the light strikes, you can hear the interference through the radio.

installations where there is a risk of a lightning strike on or near the overhead lines (or sometimes underground) supplying the installation. Equipment installed at the origin needs to be able to withstand high-voltage surges. Table 443.2 in BS 7671 gives the withstand rating of that equipment depending on the risk.

In most situations, surge protection devices are installed at the origin of the installation in order to conform with the requirements of this section. More detail on this is given in Chapter 53, within Section 534 for devices for overvoltage protection.

Section 444

Section 444 provides requirements and guidance on the avoidance of **electromagnetic interference (EMI)**.

Regulation 444.4.1 lists types of equipment that are potential sources of electromagnetic disturbance. Losing your home broadband can be disruptive, but imagine the ramifications to organisations, such as banks, of losing data and major IT networks through EMI.

Section 444 includes some methods for reducing the effects of EMI:

- segregation of data systems and wiring from low-voltage systems
- around equipment and cables, the use of earthed metallic screens or shields that act as an aerial, absorbing the EMI and protecting the equipment or cable; these shields may be built into the structure of a building around the equipment, such as in flooring systems
- minimising loops formed by data and signalling cable
- connections between neutral and earth to reduce stray currents in protective conductors, which will create electromagnetic fields around the conductors.

Regulation 444.4.1 lists types of equipment that are potential sources of EMI. These include items such as electric motors and switches, especially when the switch is controlling an inductive load, as that creates a bigger arc in the switch.

Section 445

Occurrences of **undervoltage** pose a major risk. Consider the potential consequences of undervoltage to a factory with many machines or production lines. All machines cease to operate, and an employee potentially puts their hand or head into a machine to see why it has stopped. Suddenly, the power comes back on! This could result in serious injury to that employee.

For this reason, undervoltage protection is provided for most machines we install. A simple example of an undervoltage protective device is a direct online (DOL) starter.

When you operate the green button on a DOL starter, the contactor inside makes contact and the machine starts. If there is a power cut, the contactor drops out, opening the circuit, so the only way the machine will come back on, is when someone makes sure that nobody is in a dangerous place and pushes the green button to close the contactor.

Chapter 46: Isolation and Switching

Many electrical installations include devices for switching equipment, circuits and entire installations on or off. Chapter 46 in BS 7671 states what is required to make an installation safe and functional. Chapter 53 is about the devices we can select from to ensure compliance with the requirements outlined in Chapter 46.

When we install a switch or isolator, it is intended for one or more of the following purposes:

- isolation
- functional switching
- switching off for mechanical maintenance
- emergency switching.

Other devices may be used for the purpose of firefighters' switching; see Chapter 53 in BS 7671.

Section 461

This section states that a protective earth and neutral (PEN) conductor shall not be switched. If a PEN conductor were to be switched, then an installation would lose its earthing.

Section 461 also states that, providing the earthing arrangement is a TN system, a neutral does not require isolation (except where stated in Section 462). It is common to see three-pole switches controlling three-phase installations where the neutral may be isolated by a mechanical link inside the distribution board.

Section 462

This section states the requirements for **isolation**.

Every electrical installation must have a means of isolating that installation from the supply. Isolation is achieved through use of a **linked** main switch or circuit breaker located as close to the origin of the installation as possible.

Section 462 also states that any main switch on a single-phase supply which is intended to be operated by Ordinary Persons must isolate both live conductors (line and neutral). This applies to all household or similar installations. So, the consumer unit in every house must have a double-pole switch.

In addition, every circuit must have a means of isolation, which we provide using fuses or circuit breakers.

Regulation 462.3 gives specific requirements for the locking of all isolating devices unless the device is located next to the equipment.

Section 463

Functional switching gives the ability to turn equipment on or off. A light switch in a room is an example of a functional switch.

Where functional switches are single pole, they must only switch the line conductor, with one exception.

INDUSTRY TIP

Remember, Part 5 of BS 7671 is focused on selecting the equipment.

KEY TERMS

Isolation: The disconnection and separation of an electrical installation from every source of electrical energy in such a way that this disconnection and separation is secure.

Linked: One switching action turns off all poles.

HEALTH AND SAFETY

A standard light switch should never be used for isolation!

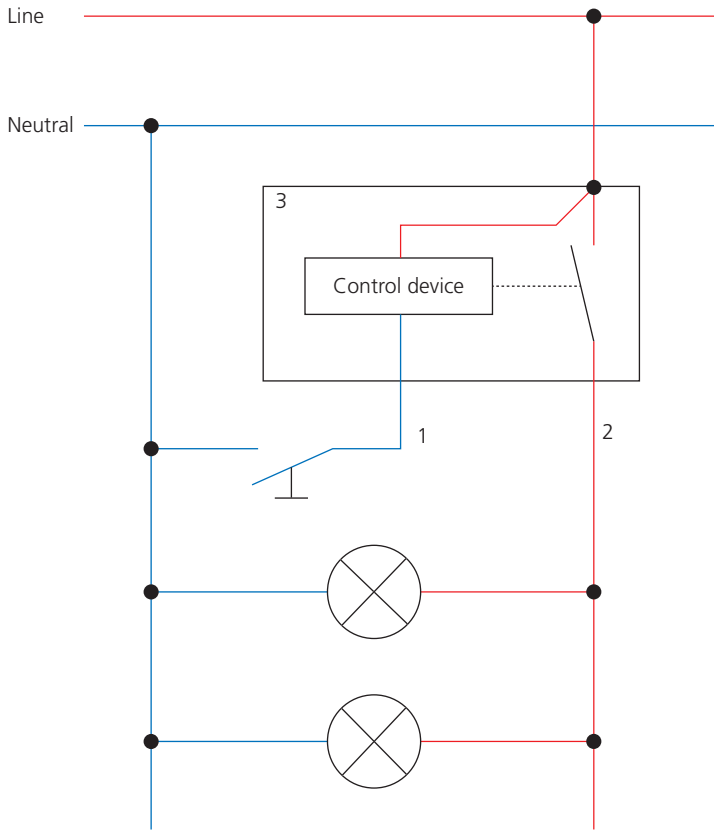

▲ Figure 3.17 Example showing where neutral switching is permissible

Figure 46.1 in BS 7671 (reproduced as Figure 3.17, here) shows the one exception where a neutral may be switched by a single-pole switch (1). The example shows a lamp control circuit where the lamps are controlled by a contactor or relay (3). In this situation, it is permissible to switch the neutral supplying the control device, but not the neutral to the lamps. The lamps are still controlled by the relay switching the line conductor (2).

Finally, this section gives requirements for the control of motor circuits for undervoltage.

Section 464

For any equipment requiring maintenance that does not involve exposure to electrical terminals, a means of switching the equipment off is required to prevent injury.

When we install equipment, we normally fit a fused connection unit or double-pole switch next to the equipment. This device is to allow maintenance on the equipment.

Look around you and see what is next to heaters, air-conditioning units and boilers. The means of switching off equipment for mechanical maintenance should ideally be next to the equipment, so it can be supervised at all times. For example, many air-conditioning units have filters inside that need regular cleaning. These filters may be next to the fan blades and if the equipment were operating, the person removing the filters may be at risk. By providing a switched fused connection unit next to the equipment, that person can reliably switch off the equipment and, as the switch is right there, ensure nobody else switches it back on.

If the device is in a location where it cannot be supervised, such as a rotary switch for a fan within large ducting, the device must be lockable.

Emergency switching

Emergency switching should be provided for any part of an installation where it is necessary to quickly remove an unexpected danger. Examples include a stop button in a workshop where a machine operator could easily and quickly switch the machine off if a dangerous situation occurred.

HEALTH AND SAFETY

If exposure to electrical parts is involved in the maintenance of the equipment, a means of secure isolation is required, and this would normally involve isolating the entire circuit.

INDUSTRY TIP

Remember, we will look at the sections within each chapter of BS 7671: 2018 (2022) that are relevant to the majority of electrical installations; some areas of specialism may be missed out.

PART 5: SELECTION AND ERECTION

In Part 4 we investigated the hazards associated with an electrical installation and ways to prevent harm. Our next task is to select and erect the installation equipment. Part 5 of BS 7671 specifies the requirements for the equipment we select and arrangements for the installation.

Chapter 51: Common Rules

As the name suggests, this chapter includes the rules that apply to all electrical installations. Consider the potential consequences if we did not standardise the colours we use to identify conductors in all electrical circuits. Non-standardisation could lead to some very dangerous situations.

Section 511

This section states that any equipment selected must comply with the relevant British Standard. If the equipment does not hold a British Standard, then the designer must verify that the equipment is of a similar standard to BS Standards, so has the same level of safety.

Section 512

This section states that equipment selected must be suitable for the operational conditions and any external influences that may affect it. Operational conditions include:

- voltage
- current
- frequency
- power
- compatibility with other installed equipment.

Section 513

This section simply states that all cable joints (except those given in Section 526) and equipment must be accessible to allow safe inspection, testing and maintenance.

Section 514

This section gives details on all required identification and notices, including:

- conductor identification by colour, letters or number (see Table 51 in BS 7671)
- the requirement to display, on or adjacent to every distribution board, diagrams and charts that give all the necessary circuit details (514.9.1)
- warning notices required for voltage and isolation (514.10, 514.11, 514.13, 514.14 and 514.15)
- general notices required for inspection and testing (514.12).

Chapter 52: Wiring Systems

This chapter covers most of the many factors that influence the choice of wiring system. When wiring systems are selected and installed, a wide range of factors and everyday activities can influence their performance.

Section 521

Much of this section states that the selected wiring system must comply with relevant standards, but it also covers areas such as:

- ensuring line and neutral conductors are run together to reduce electromagnetic effects (521.5)
- the wiring of more than one circuit within the same multi-core cable (521.7).

INDUSTRY TIP

Remember, a full list of all external influences is in Appendix 5 of BS 7671: 2018 (2022) and is broken down into three general categories. These are:

- environment (such as temperature, water, vibration, impact)
- utilisation (who is using the installation)
- building (what the building is constructed from).

INDUSTRY TIPS

Examples of these notices and labels, including the required dimensions, are contained in Appendix 11 of BS 7671: 2018 (2022).

514.9.1, requiring circuit charts to be installed next to all distribution boards, does not apply to domestic installations where a Guidance for Recipients, as detailed in Appendix 6, is issued with certification.

HEALTH AND SAFETY

Premature collapse (521.10.202)

The purpose of this regulation is to protect firefighters who are in burning buildings. Fire can cause non-metallic supports to melt, leading to the collapse of cables and systems, and trapping the firefighters or entangling their breathing apparatus.

By using a range of metallic supports, the risk of cables collapsing in these circumstances is greatly reduced.

Previously this regulation only applied to wiring systems in designated escape routes, but it now applies to all wiring.

Furthermore, that:

- circuits are arranged and distributed correctly (521.8)
- the use of flexible cables is restricted (521.9)
- non-sheathed cables are installed as per Table 4A1 in Appendix 4 of BS 7671 and that trunking provides at least IP4X protection (no gap in the trunking or lid exceeding 1 mm; see 521.10.1)
- all wiring systems are supported to prevent premature collapse (521.10.202).

Section 522

External influences are probably the greatest factors that affect the choice of wiring system. Section 522 covers choosing equipment and taking measures in order to protect the system from external influences, which include:

- ambient temperature
- heat sources, such as hot-water systems
- water and humidity
- foreign bodies, such as dust
- corrosive or polluting substances, including water or chemicals
- impact, which we will cover in detail below
- vibration, such as machine movement
- other mechanical stresses, such as bends in cables and supports, also covered in detail below
- flora (plants) and mould growth
- fauna, which are insects or animals, such as rats
- solar radiation, such as direct sunlight
- seismic effects, which are earthquakes, tremors or ground movement
- air movement, such as wind.

Impact protection

Regulation 522.6.201 states the measures that should be taken when cables are installed below a floor or in ceilings. It first identifies that the cable should not be run where the floor, ceiling or their fixings may damage it.

The regulation identifies that cables run through a joist of a ceiling or floor need to meet certain criteria. These criteria are that the cables must:

- be run at least 50 mm from the edge of the joist that is having the nails or screws driven into it; or
- be run in either armoured or mineral-insulated (MI) cables, with the armour or sheath connected to earth; or
- be run in steel conduit, which is then also connected to earth; or
- be run in steel trunking or ducting, which is then also connected to earth; or
- have additional mechanical protection on the top or bottom of each joist to prevent nails and screws from penetrating the cable; or
- be either a separated extra-low voltage (SELV) or a protective extra-low voltage (PELV) circuit.

The most common practice when installing cables through joists is to drill holes along the centre of the depth of the joist and to make sure that the top or bottom of the hole is more than 50 mm from the edge of the joist. Section 7.3.1 of the IET On-Site Guide (OSG) provides further guidance on the drilling of joists or the cutting of notches. The OSG takes into account the requirements of the Building Regulations with regards to the size, quantity and location of holes in joists.

Notes:

- 1 Maximum diameter of hole should be $0.25 \times$ joist depth.
- 2 Holes on centre line in a zone between 0.25 and $0.4 \times$ span.
- 3 Maximum depth of notch should be $0.125 \times$ joist depth.
- 4 Notches on top in a zone between 0.07 and $0.25 \times$ span.
- 5 Holes in the same joist should be at least 3 diameters apart.

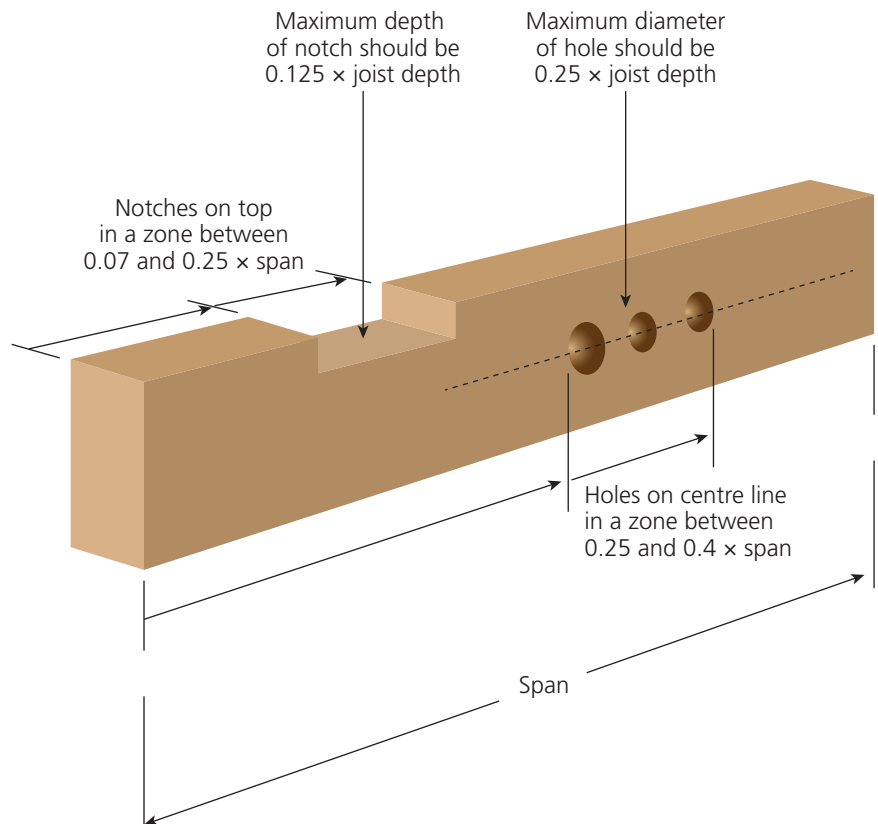

▲ Figure 3.18 Details for cutting holes or notches

Not many people damage cables installed in floor or ceiling spaces. People are most likely to damage a cable when they are mounting something on a wall. Section 522.6 identifies the measures that should be taken to protect the cable from damage when it is installed within a wall at a depth of 50 mm or less from the surface. These requirements are that the cable:

- be run in either steel-wire armoured (SWA) or mineral insulated (MI) cables with the armour or sheath connected to earth; or
- be run in steel conduit, which is then also connected to earth; or
- be run in steel trunking or ducting, which is then also connected to earth; or
- have additional mechanical protection to prevent nails and screws from penetrating the cable; or
- be run in prescribed zones of protection that extend 150 mm down from the ceiling or run in a location that falls within the width of the accessory from floor to ceiling, or the height of the accessory for the length of the wall; or
- be either a SELV or a PELV circuit.

Steel-wire armoured or mineral-insulated cable

The first option of using SWA or MI cable is not often considered, because of the additional costs associated with installing special cables. As SWA and MI cables would offer a higher-than-normal level of mechanical protection anyway, they are normally surface mounted.

Steel conduit, trunking or ducting

Approved document A states that a wall may not be chased horizontally any deeper than one-sixth of the thickness and no deeper than one-third of the thickness vertically. When the chasing is performed in a cavity wall, the thickness is that of the leaf of the wall, which is typically 100 mm. The result is that chasing cannot be deeper than 16.67 mm when running horizontally and 33.33 mm when running vertically.

This means that when a standard cavity wall forms part of the structure and needs to be chased, the options of steel conduit or steel trunking are not practical choices, as their standard sizing rules out the ability to install them deep enough to result in a flush finish for the wall.

Additional mechanical protection

The option of placing a metal plate over the cables is also not a practical choice when a standard cavity wall forms part of the structure. This is due to the thickness of the metal plate that would be required.

Prescribed zones of protection

Running cable in prescribed zones of protection is the most commonly used option within electrical installations. The IET On-Site Guide provides further guidance on the requirements of running cables within walls (see Figure 3.19, below) and focuses on clarifying where prescribed zones can be located. Another consideration is that a non-load bearing wall will not be as thick as a load-bearing wall. If it has a thickness of up to 100 mm, then the prescribed zone will be on both sides of the wall.

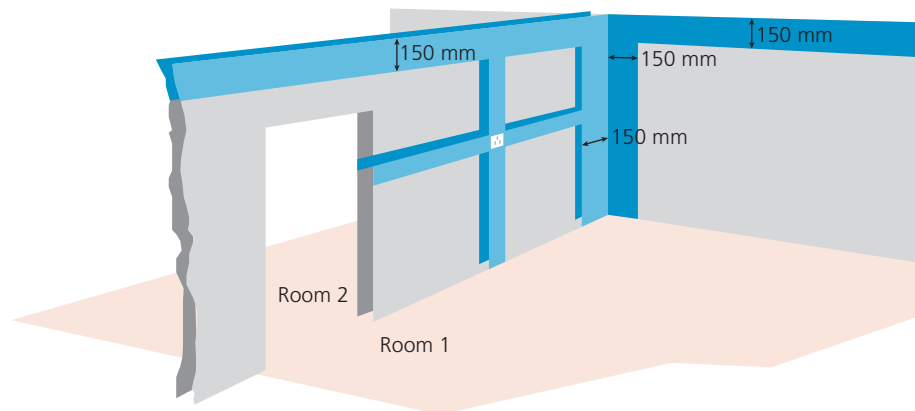

▲ Figure 3.19 Prescribed zones of protection

Stud walls

Not all walls are built the same. In many commercial and industrial properties, the use of a metal stud within a partition wall is common. Where cables are installed in walls built with metal studs, then further protection is required as per Section 522.6.

HEALTH AND SAFETY

Prescribed zones are also commonly known as 'safe zones'; however, this can be misleading as it gives the impression that if the cables are run in the zones, then everything is safe. Though the cables are run in these locations they still cannot be seen and the installation user may not be aware of our industry standards. This means that a nail or screw could still end up being driven through a cable.

Section 522.6 takes this into account and advises that, when a cable has been installed in prescribed zones and no other mechanical protection has been provided, and the circuit is not SELV or PELV, then additional protection must be provided for the circuit. The additional protection referred to is that of a residual current device (RCD) with a rating not exceeding 30 mA. Should the cable be penetrated, and a person were to touch the nail or screw, the RCD would operate and keep the person safe.

The regulation states that, when cables are installed in metal stud walls, similar requirements apply as for cables in a wall at a depth of less than 50 mm, with the exception that prescribed zones do not apply. Instead, if no other mechanical protection is provided, then the circuit must be provided with **additional protection** in the form of an RCD with a rating not exceeding 30 mA. This applies to all cables within the wall, irrespective of how deep they are, as it is the studs that provide the hazard, not just the cable being penetrated by nails and screws.

KEY TERM

Additional protection by an RCD is in addition to the basic protection. If someone puts a nail or screw through a cable, they have compromised the basic protection (the insulation).

Other mechanical stresses

Regulation subsection 522.8 deals with the other stresses and strains to which a cable may be subjected. This includes the strain that can come from the weight of the cable itself. Copper is a reasonably heavy material, but it is also soft, which means if the cable is not supported correctly, then the copper will stretch. This will result in the csa of the copper conductors becoming smaller, which can cause the cable to get hot or even break. Regulation 522.8.4 states:

‘Where the conductors or cables are not supported continuously due to the method of installation, they shall be supported by suitable means at appropriate intervals in such a manner that the conductors or cables do not suffer damage by their own weight.’

This means that when cables are installed using cable clips or cleats, then the clips and cleats must be at ‘appropriate’ intervals. The IET OSG provides guidance on what is deemed to be ‘appropriate’ within Appendix D, specifically in Table D1 (reproduced as Table 3.5, below).

▼ Table 3.5 Table D1 spacings of supports for cables in accessible positions

Overall diameter of cable, d* (mm)	Maximum spacings of clips (mm)							
	Non-armoured thermosetting or thermoplastic (PVC) sheathed cables				Armoured cables		Mineral-insulated copper-sheathed or aluminium-sheathed cables	
	Generally		In caravans					
	Horizontal**	Vertical**	Horizontal**	Vertical**	Horizontal**	Vertical**	Horizontal**	Vertical**
1	2	3	4	5	6	7	8	9
d ≤ 9	250	400	250 (for all sizes)	400 (for all sizes)	-	-	600	800
9 < d ≤ 15	300	400			350	450	900	1200
15 < d ≤ 20	350	450			400	550	1500	2000
20 < d ≤ 40	400	550			450	600	-	-

Note: For the spacing of supports for cables having an overall diameter exceeding 40 mm, the manufacturer’s recommendations should be observed.

* For flat cables taken as the dimension of the major axis.

** The spacings stated for horizontal runs may be applied also to runs at an angle of more than 30° from the vertical. For runs at an angle of 30° or less from the vertical, the vertical spacings are applicable.

Source: Table D1, On-Site Guide, IET

One common area where this matter also needs to be considered is when wiring is installed within vertical trunking, as the weight of the wiring itself will cause it to stretch. If the top bend is a right angle, then the cable's weight will be applied at the edge of the trunking, causing it to cut into the wiring. On long drops it is common to install support pins within the trunking, with the wiring woven between the pins, which helps to provide support to the cables.

Another source of stress and strain that cables encounter is when they are bent too tightly, causing pressure to be applied not only to the conductors, but also to the insulation of the cable. In the case of PVC-insulated cables, when the conductors carry the load current and get hot, this will warm the PVC, making the insulation soft and easy to split. With the added pressure of the bend, the copper conductors can easily cut through the softened insulation, causing a fault to occur. Regulation 522.8.3 states:

‘The radius of every bend in a wiring system shall be such that conductors or cables do not suffer damage and terminations are not stressed.’

When planning the route of a cable, consideration needs to be given to the number and tightness of the bends. Appendix D in the IET OSG, specifically Table D5 (reproduced as Table 3.6, below), gives guidance on the minimum bend radius of cables to ensure they are not subjected to undue stress and strain.

▼ Table 3.6 Table D5 minimum internal radii of bends in cables for fixed wiring

Insulation	Finish	Overall diameter, d* (mm)	Factor to be applied to overall diameter of cable to determine minimum internal radius of bend
Thermosetting or thermoplastic (PVC) (circular, or circular-stranded copper or aluminium conductors)	Non-armoured	$d \leq 10$	3(2)**
	Armoured	$10 < d \leq 25$	4(3)**
		$d > 25$	6
		Any	6
Thermosetting or thermoplastic (PVC) (solid aluminium or shaped-copper conductors)	Armoured or non-armoured	Any	8
Mineral	Copper sheath with or without covering	Any	6***

* For flat cables, the diameter refers to the major axis.

** The value in brackets relates to single-core circular conductors of stranded construction installed in conduit, ducting or trunking.

*** Mineral-insulated cables may be bent to a radius not less than three times the cable diameter over the copper sheath, provided that the bend is not reworked, i.e. straightened and re-bent.

Source: Table D5, On-Site Guide, IET

All of these considerations will have an impact, not only on the type of cables chosen, but also on the method of installation.

Section 523

Section 523 of BS 7671 outlines the requirements to be met when sizing cables. It covers the need to limit the conductor temperature under normal operating conditions and states the maximum operating temperatures of conductors, based on their insulating material.

▼ Table 3.7 Temperature limit of insulation

Type of insulation	Temperature limit
Thermoplastic	70°C at the conductor
Thermosetting	90°C at the conductor
Mineral-insulated copper-clad cable (MICC) that can be touched	70°C at the sheath
MICC that cannot be touched	105°C at the sheath

When a conductor is installed, several factors have an impact on the temperature of the conductor and the cable itself. A conductor's primary function is to carry electrical energy from the source to the destination. If the opposition to the flow of the electrical energy (the resistance) is too great, then insufficient energy will reach the load in order for it to function correctly.

Resistance is affected not only by the material, its length and its area, but also by temperature. If temperature is not considered during the design and installation stages, then the conductor may well become undersized and in turn will overheat.

Like a person doing physical exercise, a conductor has three things that can stop it cooling. These are:

- the surrounding ambient temperature
- the closeness of other heat sources, such as other loaded cables
- being wrapped in thermally insulating material.

These three main factors must be considered when selecting a conductor size. Section 532 of BS 7671 states that Appendix 4 should be used to size conductors. A series of tables in Appendix 4 identifies correction factors that are applied to the current rating of the circuit being designed, based on the rating of the protective device. These correction factors include:

- C_a – ambient temperature
- C_c – circuits buried in the ground
- C_d – depth of burial
- C_f – use of a **BS 3036** fuse
- C_g – grouping of circuits
- C_i – thermal insulation
- C_s – thermal resistivity of soil.

Chapter 4 of this book will look at these factors and Section 524 of BS 7671 in more detail.

Section 526

This section details the types of electrical connections permitted and what must be taken into account. It also gives requirements for cable joints that do not need to be accessible (526.2).

INDUSTRY TIP

Although possible, the use of a **BS 3036** fuse for new installations or circuits will be very unlikely as it would be difficult to provide necessary RCD (additional) protection or AFDD protection.

INDUSTRY TIP

Much of Chapter 53 of BS 7671 covers overvoltage protective devices and these are beyond the scope of this book.

INDUSTRY TIP

Selectivity is now the word used for discrimination. Many people will still refer to it as discrimination.

KEY TERMS

Pre-arcing (time): The time taken for a device to react to an overcurrent, up to the point where the device breaks and arcs.

Maximum operating characteristic: The time a device takes to complete the operation of disconnection – including pre-arcing time, arcing and disconnecting – leaving a gap big enough to prevent current flow. Manufacturers provide detailed graphs showing pre-arcing characteristics. Graphs in BS 7671 only show maximum operating characteristics.

Selectivity will be achieved for fuses if an upstream device is more than twice the rating of any downstream device. For example, if the upstream fuse (A) has a rating of 80 A and the local downstream fuse (B) is 32 A, selectivity would be achieved as neither of the characteristic curves cross one another.

Chapter 53: Isolation and Switching

This chapter deals with the selection and installation of devices used for:

- protection, such as fuses, circuit breakers used for protection against electric shock and overcurrent protection
- isolation
- switching devices for functional purposes, emergency and mechanical maintenance
- control devices for functional purposes
- monitoring devices, such as insulation monitors (IMs) or residual current monitors (RCMs).

Guidance is also given for the different types of RCD and where they should be used (531.3.3).

In Chapter 53, useful tables include:

- Table 53.1 – an extension of Table 41.5, which we saw when we looked at protection against electric shock (Chapter 41 of BS 7671) and allows for RCDs that have a residual current setting exceeding 500 mA. Table 53.1 covers RCDs with residual current ratings of 1000 mA (1 A) to 20 000 mA (20 A).
- Table 537.4 – shows what devices can be used for isolation, emergency switching and functional switching.
- Table A53.1 in Annex A53 – shows the different types of protective device and what they protect against. For example, it shows that a circuit breaker is classed as an overcurrent protective device and is suitable for overloads and short circuits but is not suitable for residual current protection or switching.

Selectivity of protective devices is also covered in Section 536 and Annex A53, which give guidance on coordination of devices to provide selectivity. Correct coordination allows for local devices to disconnect before main fuses or circuit breakers.

Selectivity between devices

Effective selectivity is achieved when a designer ensures that local protective devices disconnect before others located closer to the origin of the installation.

Selectivity is required:

- under normal load conditions
- under overload conditions.

In the event of a fault, selectivity is desirable, but if no danger and no inconvenience arise it may not be necessary.

Fuse-to-fuse selectivity

Two fuses in series will provide selectivity between one another under overload and fault conditions if the maximum **pre-arcing** characteristic of the upstream device exceeds the **maximum operating characteristic** of the downstream device.

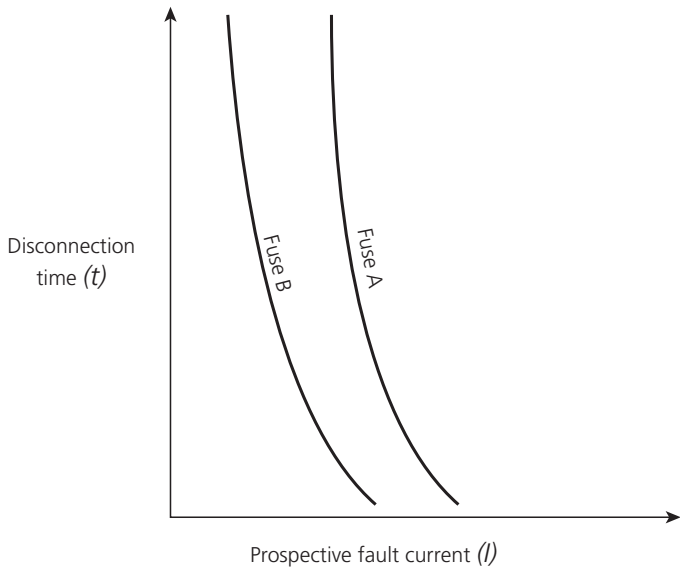

▲ Figure 3.20 Fuse characteristics

Circuit breaker to circuit breaker

The characteristics of circuit breakers are different from those of fuses. The circuit breaker has two characteristic features:

- a thermal characteristic similar to a fuse
- a magnetic characteristic that, when at a specified current, causes the circuit breaker to operate instantaneously (see Figure 3.21, below).

If the fault current exceeds the instantaneous operating current of the upstream device, there may not be selectivity if the two devices have the same frame type, whatever their ratings, as both devices may operate at the same time.

Manufacturers will provide information on circuit-breaker selectivity. It will normally be achieved by selecting different frame types for the upstream and downstream circuit breakers.

In some situations, a local circuit breaker may be of a different type to one installed nearer the origin. Even though the local device is only rated at 32 A (Type D) and the distribution device is rated at 100 A (Type B), selectivity will not be achieved.

Looking at Appendix 3 in BS 7671, we can see that a 32 A Type D circuit breaker will disconnect at a current of 640 A, whereas a 100 A Type B will disconnect at 500 A fault current. This means that the 100 A device will disconnect before the 32 A device.

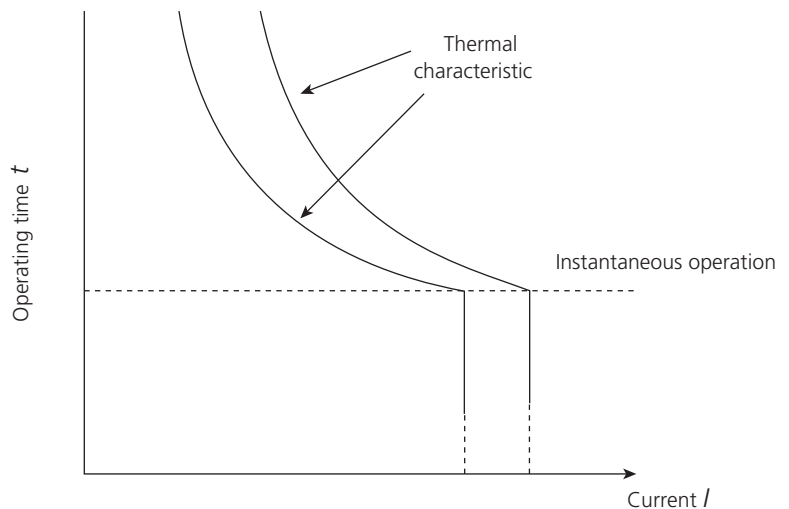

▲ Figure 3.21 Circuit-breaker characteristics

Chapter 54: Earthing Arrangements and Protective Conductors

Within an electrical installation there are several protective conductors. These are:

- the earthing conductor – linking the main earthing terminal (MET) to the means of earthing
- main protective bonding conductors – linking the MET to extraneous parts
- circuit protective conductors (cpc) – linking exposed conductive parts
- supplementary equipotential bonding conductors – linking exposed to extraneous parts
- high-integrity protective conductors – providing reliable connections to earth for equipment having protective conductor currents.

Chapter 54 details the requirements for the selection and arrangements of these conductors.

Section 542

This section provides detail on the supply arrangements, particularly earth electrodes. Regulation 542.2.2 gives a list of what may be used as an earth electrode.

As the earthing conductor for a TT installation is buried in order to reach the earth electrode, Table 54.1 in BS 7671 gives minimum permitted csa for these conductors depending on the cable material and the cable being protected against corrosion and mechanical damage.

Regulation 542.2.3 mentions **foundation earth electrode**. These are earth electrodes installed into the concrete foundations of a building, providing the concrete is in contact with the soil beneath it. Reinforcement used for the concrete may be used as the foundation electrode providing the reinforcement complies with regulation 542.2.8, and the reinforcement connections shall be made by welding, pressure connectors, clamps, or other suitable mechanical connectors. Using wrapped wire to form a connection between **rebars** is not suitable.

INDUSTRY TIP

Note that the minimum permitted size is a 2.5 mm² conductor. This is because a TT installation is protected by an RCD and therefore the earth fault current is unlikely to be high.

KEY TERMS

A **foundation earth electrode** is defined in BS 7671 as a conductive part buried in the soil under a building foundation or, preferably, embedded in concrete of a building foundation, generally in the form of a closed loop.

Rebars are steel bars used to reinforce concrete.



▲ Figure 3.22 Concrete being poured onto rebars to form a building foundation

There are several advantages to having foundation electrodes and these include:

- the provision of additional earth electrodes providing alternative paths for diverted neutral currents in the event of an open circuit supply PEN conductor
- they reduce the risk of electric shock for installations using Automatic Disconnection of Supply (ADS) by connecting the partially conductive floor to the bonding network
- they provide a suitable earthing provision when a prosumer's (see page 105) electrical installation (PEI) is in island mode (see Part 8 of BS 7671:2018 (2022))
- they help with reducing the effects of electromagnetic interference (EMI) by grounding metalwork, providing a means of shielding sensitive equipment, in the same way as some methods given in Section 444 of BS 7671.

INDUSTRY TIP

Where a foundation electrode is embedded in the foundation or is a separate ring, these are known as horizontal systems as the electrode is laid out horizontally.

Section 543

This section gives detail on what can be used as a protective conductor, such as a cpc or earthing conductor, as well as guidance on the correct csa.

Regulation 543.1.1 states that the csa can be sized in two ways:

- using Table 54.7 in BS 7671 and based on the circuit line conductor
- using the adiabatic equation.

IMPROVE YOUR MATHS



The adiabatic equation

This equation, in this format, is used to determine the minimum csa for a protective conductor (cpc or earthing conductor) under specific fault currents for specific durations.

Any smaller csa would cause the cable to exceed its 'final limiting temperature' and fail. The adiabatic equation is as follows:

$$S = \frac{\sqrt{I^2 t}}{k} \text{ in mm}^2$$

Where:

- S is the minimum acceptable size of cpc for the expected earth fault current
- I is the actual fault current based on the total earth fault loop impedance (Z_s)
- t is the actual disconnection time, using the graphs in Appendix 3
- K is the factor from Tables 54.2–54.5 in BS 7671, depending on how the cpc is installed.

Using the adiabatic equation step by step

- 1 Calculate the $R_1 + R_2$ for the circuit.
- 2 Determine the total earth fault loop impedance (Z_s).
- 3 Determine the actual earth fault current, using Ohm's law.
- 4 Use the graphs in Appendix 3 to work out the actual disconnection time (down to 0.1 seconds).

- 5** Determine the factor k from the following tables in BS 7671:
- Table 54.2, where the cpc is not incorporated in a cable or bunched. Examples may be the separate earthing conductor for an installation, the sheath of a mineral-insulated copper-clad (MICC) cable and a separate overlay cpc tagged to a steel-wired armour (SWA) cable.
 - Table 54.3, where the cpc is bunched or a core within a cable.
 - Table 54.4, where the armouring of an SWA cable is used as a cpc.
 - Table 54.5, where a containment, such as conduit or trunking, is used as a cpc.
- 6** Apply the adiabatic equation:

$$S = \frac{\sqrt{I^2 t}}{k} \text{ in mm}^2$$

If the value from the equation in mm^2 is smaller than the actual cpc csa, then the circuit is acceptable.

Adiabatic equation: example

A 230 V single-phase circuit is wired using 70°C thermoplastic flat-profile twin and cpc cable having 2.5/2.5 mm^2 copper conductors to a length of 43 m. The supply earth fault loop impedance (Z_e) is 0.1 Ω . Protection is by a 20 A Type C circuit breaker.

Using Table I1 in the IET On-Site Guide, a 2.5/2.5 mm^2 combination of conductor has a resistance of 14.82 $\text{m}\Omega/\text{m}$ at 20°C. Using Table I3, a factor of 1.2 is selected to allow for operating temperatures.

To calculate $R_1 + R_2$

$$\frac{14.82 \times 43 \times 1.2}{1000} = 0.76 \Omega$$

So, Z_s is:

$$0.1 + 0.76 = 0.86 \Omega$$

And therefore the fault current would be:

$$\frac{230}{0.86} = 267 \text{ A}$$

Using tables in Appendix 3 of BS 7671, the approximate disconnection time for this fault current is within 0.1 seconds.

Looking at Table 54.2 in BS 7671, as the cpc is incorporated in the cable, the value of k is 115.

Applying the adiabatic equation, the minimum cpc to handle this fault current for this duration of time, would be:

$$A = \frac{\sqrt{267^2 \times 0.1}}{115} = 0.73 \text{ mm}^2$$

As the cpc is actually 2.5 mm^2 , this is acceptable.

ACTIVITY



Determine the minimum acceptable cpc csa for a circuit protected by a 32 A Type B circuit breaker where the fault current to earth has been determined as 100 A. The cpc is a core within a 70°C thermoplastic multi-core cable.

Section 543 also gives requirements on what can be used as a protective conductor (see regulation 543.2.1), as well as earthing requirements for equipment having high protective conductor currents (see Section 543.7).

Types of equipment having high protective conductor currents are items that leak current to earth in order to function. These may include electronic or business equipment having filtered power supplies such as fixed PC workstations, printers or photocopiers.

In order to keep a reliable connection to earth for this earth leakage current, high integrity earth connections are needed depending on how the equipment is connected to the final circuit.

Section 544

This section deals with the csa and connection of bonding conductors. Note that the bonding conductors for a protective multiple earthing (PME) system must be larger than those of TN-S or TT.

BS 7671: 2018 (2022) now requires each building to have its own main protective bonding rather than each installation, which may have covered several buildings. In addition, if a building has several electrical installations, such as a block of flats, each installation requires main protective bonding. In these situations, the bonding is sized in accordance with the distribution circuit cable supplying that installation or building.

Regulation 544.1.2 states that where the bonding connection is made, metallic pipework, such as gas and water, must be bonded at the point of entry. Alternatively, if the meter or isolation point is within the installation, bonding must be connected on the consumer's side, within 600 mm of that point and before any junction.

Chapter 55: Other Equipment

As the title of this chapter suggests, whatever has not been covered in Chapters 51–54 will likely be covered here.

Much of Chapter 55 deals with:

- British Standards equipment that must be used for items such as socket outlets
- the arrangements for generator sets and how they are connected to an installation depending on their function (Section 551)
- requirements for specialised current-using equipment that includes:
 - electrode water heaters
 - immersed heating elements (immersion heaters)
 - heating conductors, such as trace heaters or soil heaters (Section 554).

Section 559 has the requirements for lighting installations and luminaires. Regulation 559.5.1 gives methods of connection for lighting to the fixed wiring system. Table 55.3 in BS 7671 shows common symbols associated with lighting systems.

ACTIVITY



A building is supplied using a cable having an earthing conductor with a 16 mm² csa. What is the minimum size of main protective bonding permitted for that building where the supply to the whole electrical installation forms a TN-S arrangement?

INDUSTRY TIP

Even though the minimum csa for a main protective bonding conductor is 6 mm², most electrical contractors will always install 10 mm² as the minimum.

Remember, though, just because most electrical contractors will install this size, it does not make a 6 mm² conductor incorrect if you are carrying out periodic inspections on an installation not on a PME supply.

PART 6: INSPECTION AND TESTING

The content of Part 6 of BS 7671 is covered in detail in Chapter 6 of this book.

There are two chapters in Part 6 of BS 7671. These are:

- Chapter 64, which gives requirements for the inspection, testing and certification for an initial verification
- Chapter 65, which gives requirements for the inspection, testing and reporting of periodic inspections.

PART 7: SPECIAL INSTALLATIONS OR LOCATIONS

When electrical installations are designed and installed, it is important to bear in mind that, although standard external influences must be considered when selecting and erecting equipment, not all installations are the same. In fact, not all parts of an installation may be the same. BS 7671: 2018 recognises that, in some areas of an installation, there is a higher risk of electric shock due to the nature of the location or type of installation.

BS 7671: 2018 identifies these locations and installations as 'special' and Part 7 lists them. When considering the work to be performed in a special location, or a special installation, it is important to understand the special requirements in terms of the international protection (IP) code ratings and changes to the protection required.

As Section 701, which deals with locations with baths or showers, is the most common section, we will look at this in detail.

INDUSTRY TIP

Section 701 does not apply to facilities that are there for emergency, such as Hazmat showers and decontamination showers.

Section 701: Locations with baths or showers

BS 7671 does not use the term 'bathroom' as this implies only one room, and baths and showers can be found in a variety of locations, including:

- bathrooms
- shower rooms
- wet rooms
- changing rooms
- utility rooms
- bedrooms
- birthing rooms.

In fact, Section 701 applies to anywhere that a bath or shower is located which is for general use.

Zones

A room containing a bath or shower has different levels of risk of electric shock in different areas of the location. BS 7671 splits the room up into different areas, based on the different levels of risk. These areas are called zones and can be simplified as shown in Table 3.8 (below).

▼ Table 3.8 Zones according to BS 7671

Zone	Description
0	This is the area where the water is held and it can be any size or shape, depending on the size and shape of the bath or basin.
1	This is the area of the perimeter of the bath or basin from the floor to a maximum height of 2.25 m. This would be the area occupied by a person if they were sitting or standing in zone 0.
2	This is the area immediately outside the perimeter of the bath or basin to a distance of 0.6 m from the bath or basin, to a maximum height of 2.25 m. This is the area that can be reached by extending an arm while sitting or standing in zone 0.

INDUSTRY TIP

Section 701 contains diagrams showing the zones.

In some instances, there may be a shower with no basin, for example, in a wet room or the showers at a sports gym. The zones in such circumstances are further clarified in BS 7671, in Figures 701.1 and 701.2. If a shower head is installed at a height greater than 2.25 m from the floor, then the height of zones 1 and 2 will be increased to the height of the shower head.

Selection of equipment

Because the location has been split into zones based on risk, each zone has different requirements with regards to the equipment that can be installed. The main focus in this location is the presence of water and so the IP ratings of equipment and accessories are important.

▼ Table 3.9 Equipment requirements according to zone

Zone	Equipment requirements
0	<ul style="list-style-type: none"> ● All equipment must have a minimum IP rating of IPX7. ● No switches or controls are to be installed in this zone. ● Only permanently connected, purpose-built equipment that operates on SELV with a voltage not exceeding 12 V AC rms may be installed.
1	<ul style="list-style-type: none"> ● All equipment must have a minimum IP rating of IPX4. ● Only switches and controls of SELV circuits with a maximum voltage of 12V AC rms are allowed. ● Only permanently connected, purpose-built equipment, such as electric showers, heated towel rails and luminaires, may be installed unless they are protected by SELV or PELV and have a voltage not exceeding 25 V AC rms.
2	<ul style="list-style-type: none"> ● All equipment must have a minimum IP rating of IPX4, except shaver-supply units complying with BS EN 61558-2-5, as long as they are installed where they are not likely to get wet from showers. ● Only switches and controls of SELV circuits are allowed. ● Only permanently connected, purpose-built equipment may be installed.

HEALTH AND SAFETY

Consider why the distance from the edge of the bath to any 230 V, 13 A socket outlet is 2.5 m. What is the average length of flexible cable fitted to most appliances? Have a look at a hairdryer or similar appliance.

Other key points to consider

- When performing electrical installations within a location containing a bath or shower, all circuits within the location need to be RCD-protected, in accordance with Regulation 701.411.3.3. This requires an RCD with a maximum rating of 30 mA.
- Supplementary equipotential bonding should be installed between all exposed metal work of the accessories fitted and extraneous conductive parts. This is to maintain the potential between these parts to 50 V AC or less.
- However, Regulation 701.415.2 makes it clear that equipotential bonding between all exposed metal work is not always required if the installation is within a location which already has main protective bonding installed. In order to omit supplementary equipotential bonding, three criteria must be met. These criteria are:
 - all final circuits within the location must meet the maximum disconnection times stated within Table 41.1 of BS 7671: 2018 by having an earth fault loop impedance, Z_s , within the limits specified in Tables 41.2 to 41.4, and
 - all final circuits of the installation must have additional protection in the form of an RCD, and
 - all extraneous conductive parts must be effectively connected to the main protective bonding.

The first two requirements are quite simple to establish but the third option requires a confirmation by testing. Using continuity test method 2 (from Guidance Note 3), the resistance between the metal part of the location and the MET can be measured. If the reading is low enough, then supplementary equipotential bonding is not required. The note below Regulation 701.415.2 identifies how to establish this. On a 30 mA RCD, the maximum resistance before supplementary bonding is required is 1667 Ω . If a reading above this value is obtained, then supplementary equipotential bonding is required. If a reading above 1 M Ω is obtained, then it can be confirmed that supplementary equipotential bonding is not required as the metal part of the location is insulated from earth and therefore is not an extraneous conductive part.

Other special locations

As mentioned earlier, BS 7671 covers many other special locations and installations, including:

- swimming pools and basins (702)
- sauna heaters (703)
- construction and demolition sites (704)
- agricultural and horticultural premises (705)
- conducting locations with restricted movement (706)
- caravan and camping parks (708)
- marinas (709)
- medical locations (710)

- exhibitions, shows and stands (711)
- solar photovoltaic (712)
- mobile and transportable units (717)
- caravans and motor homes (721)
- electric vehicle charging installation (722)
- gangways (729)
- onshore units of electrical shore connections for inland navigation vessels (730)
- fairgrounds, amusement parks and circuses (740)
- electric floor and ceiling heating (753).

INDUSTRY TIP

Note: Amendment 3 of BS 7671 also includes outdoor and low-voltage lighting as special installations.

Each special installation or location requires careful consideration with regards to how the installation is designed and installed. It is important for both the designer and installer to be familiar with the additional special requirements as specified in the relevant section of BS 7671.

Common key points to consider include the requirements for a higher level of IP rating than normal, the provision of additional protection by supplementary equipotential bonding and RCDs, and the use of SELV or PELV with restricted values.

PART 8: FUNCTIONAL REQUIREMENTS

Every edition and amendment of BS 7671 up to the year 2022 has only contained requirements that uphold the Fundamental Principles for safety as set out in Chapter 13.

As technology advances, there is more of a need to include requirements leading to the correct function of electrical installations and equipment. As a result, Part 8 has been introduced into BS 7671.

Chapter 82: Prosumers' low-voltage electrical installations

This is an entirely new chapter introduced into BS 7671:2018 (2022). Since electricity was first delivered to buildings by a supply network, utility companies have managed the public transmission and distribution network by having generators coming on- and offline to suit the national demand variations.

The purpose of this Chapter is to provide requirements so that electrical installations are suitable with the current and future ways of delivering electrical energy to current-using equipment, either from the public supply network, or from other local sources such as photovoltaic (PV) arrays on a house, a micro-wind turbine, or even a fully charged electric vehicle.

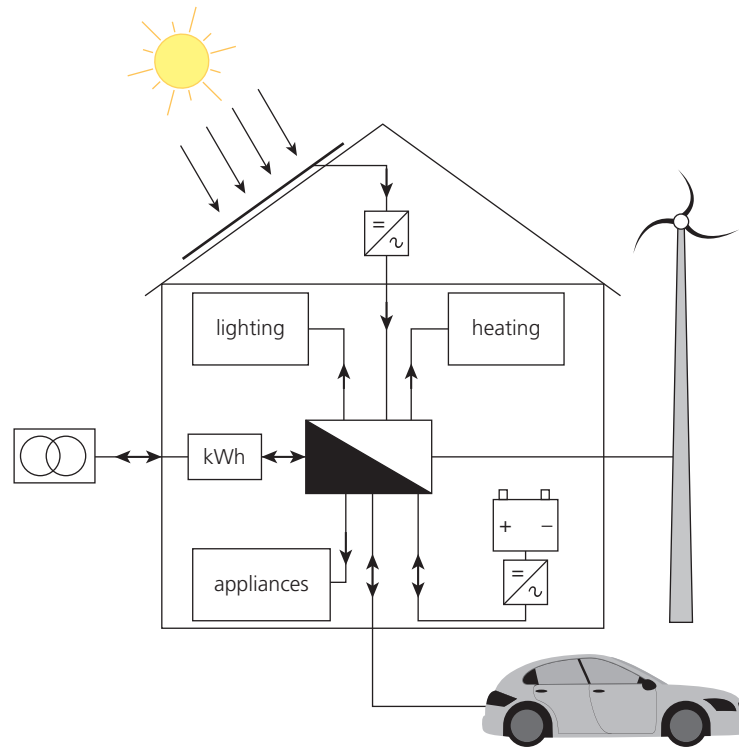

▲ Figure 3.23 A prosumer's installation which can consume energy from the public supply network as well as its own generator or electricity storage systems

Chapter 82 introduces some new terminology into BS 7671 such as:

- **prosumer:** someone who both consumes (uses) electricity from the supply network and produces electricity either for their own consumption, or to feed into the public network.
- **island mode:** an operating mode where a prosumer's electrical installation is disconnected from the public supply network but remains energised by the electricity being generated or stored locally within the electrical installation.
- **load shedding:** a system of energy management where appliances and other loads are controlled to suit times of peak demand, reducing consumption from the public supply network.

APPENDICES

BS 7671: 2018 (2022) includes Appendices that contain additional information in respect of the regulations. Table 3.10 (below) lists these Appendices and briefly describes their content.

▼ Table 3.10 Outline of BS 7671 Appendices

BS 7671: 2018 Appendix	Description
1 British Standards to which reference is made in BS 7671	Every British Standard (BS) or European Standard (EN) used within BS 7671 is listed and briefly described in this Appendix.
2 Statutory regulations and associated memoranda	This Appendix is a guide to statutory regulations and guidance that may need to be studied where installation work is carried out in the specific areas.
3 Time/current characteristics of overcurrent protective devices and residual current devices	Graphs show disconnection times of devices depending on the level of fault current.
4 Current-carrying capacity and voltage drop for cables	There are many tables in this section relating to the sizing and current capacity of live conductors.
5 Classification of external influences	Every possible external influence that can impact on an installation is listed here with detail.
6 Model forms for certification and reporting	Blank copies of forms used for inspection and testing are reproduced in this Appendix. BS 7671: 2018 (2022) has introduced revamped versions of the certificates, reports and schedules.
7	This Appendix is not used.
8 Current-carrying capacity and voltage drop for busbar trunking and powertrack systems	This Appendix includes specific guidance for busbar trunking and powertrack systems.
9 Definitions	This Appendix gives definitions for multiple source, DC and other systems arrangements, for systems not shown in Section 312.
10 Protection of conductors in parallel against overcurrent	This is a specialist area for ring distribution systems.
11 Warning and user instruction labels	Examples of the wording used for labels and instructions including dimensions.
12	This Appendix is not used.
13 Escape routes and fire protection	Guidance on what is classed as a designated escape route and the fire sealing of building elements.
14 Determination of prospective fault current	Guidance is given on the calculations for prospective current fault when inspecting and testing electrical installations.
15 Ring and radial final circuit arrangements, Regulation 433.1	Drawings show guidance on the arrangements of ring and radial circuits.
16 Devices for protection against overvoltage	Arrangements for overcurrent protection devices are included in this Appendix.
17 Energy efficiency	Appendix 17 is very detailed, giving guidance on the arrangements for electrical installations in order to improve energy efficiency.

In addition to the Appendices, the index of BS 7671 includes two tables that are useful. These tables show:

- the location of all the diagrams in BS 7671
- the location of all the tables in BS 7671.

Test your knowledge

If you answer incorrectly, don't lose heart – see it as an opportunity to hone your navigation skills. Use the Chapter or Section number highlighted in the answer section to find your own way through the regulations to the correct answer. As they say: Practice makes perfect.

- 1** Which installation is not within the scope of BS 7671?
 - a** Locations with a swimming pool.
 - b** Locations on a caravan park.
 - c** Equipment on board aircraft.
 - d** Equipment for exhibitions.
- 2** Which of the following is a fundamental principle when considering the method of installation?
 - a** Nature of the location.
 - b** Expected current demand.
 - c** Overcurrent protection.
 - d** Daily variations in demand.
- 3** What is a deliberate decision not to comply with BS 7671 defined as?
 - a** Limitation.
 - b** Departure.
 - c** Compliance.
 - d** Diversity.
- 4** What is the abbreviation for a protective device which is a residual current circuit breaker with integral overcurrent protection?
 - a** RCD.
 - b** OPD.
 - c** RCM.
 - d** RCBO.
- 5** Which earthing arrangement uses protective multiple earthing (PME)?
 - a** IT.
 - b** TT.
 - c** TN-C-S.
 - d** TN-S.
- 6** What is a characteristic of equipment that must be assessed for compatibility?
 - a** Power factor.
 - b** Design current.
 - c** Light output.
 - d** Weight.
- 7** Which of the following is a method of basic protection?
 - a** Bonding.
 - b** Earthing.
 - c** Insulation.
 - d** RCBOs.
- 8** What requires connection directly to the main earthing terminal (MET) by main protective bonding when automatic disconnection of supply (ADS) is the protective measure against electric shock?
 - a** Metal trunking.
 - b** Metal conduit.
 - c** Metal gas supply pipes.
 - d** Metal door frames.

WORKING ON SITE

INTRODUCTION

Organising and overseeing the workplace environment is a skill expected of most qualified electricians. Many electricians are expected to be able to plan electrical installation work, from the initial contact with the client, through supervising others during the construction stage, to final handover to the client. For large contracts, these tasks might involve more than one person. For the majority of electrical installation work in the UK, however, one person will carry them out.

The key to success within the electrotechnical industry is the ability to plan and supervise effectively. Careful planning will minimise any surprises during the work and lead to timely completion with little or no additional cost. Effective supervision will lead to reduced wastage of time and materials. Each will lead to good customer relationships, improved company image and, very importantly, a motivated and contented workforce.

Above all else, good planning promotes safety.

HOW THIS CHAPTER IS ORGANISED

T Level mapping grids are available on the Hodder Education website. These map the book to the occupational specialisms: 8710-353 (Electrical Engineering) and 8710-352 (Electrical and Electronic Equipment).

This unit covers the understanding needed to plan a worksite. Because of the way some units within **5357** and **5393** are written, some of the knowledge that belongs to the design unit sits here as it is much more related to planning work activities than electrical design. As **2365** does not have a specific unit relating to planning the worksite, much of the understanding covered here is within the **2365-305** unit.

There is a lot of crossover of information between Chapters 3, 4 and 5 in this book. The intention is to link as much learning that is unrelated to design calculations as possible. This will leave you prepared to focus on the design procedures in Chapter 5.

Table 4.1 shows the topics covered in this chapter.

▼ Table 4.1 Chapter 4 assessment criteria coverage

Topic	5357	2365 Unit 305: Electrical Systems Design	8202 Unit 301: Planning and Overseeing Electrical Work Activities	5393
Information: <ul style="list-style-type: none"> ● Information from others ● Information from employer organisation ● Contracts Customer service principles	Unit 105/005: Understand How to Plan and Oversee Electrical Work Activities 2.3; 2.4	1.2	2.3	Unit 105/005: Understand How to Plan and Oversee Electrical Work Activities 2.3; 2.4 3.4; 3.5; 3.6 4.1; 4.2; 4.3

▼ Table 4.1 Chapter 4 assessment criteria coverage (continued)

Topic	5357	2365 Unit 305: Electrical Systems Design	8202 Unit 301: Planning and Overseeing Electrical Work Activities	5393
Planning the worksite: <ul style="list-style-type: none"> ● The work environment ● Site services ● Site meetings ● Site induction training ● Pre-existing damage ● Managing a safe site ● Managing an efficient site 	Unit 104/004: Understand Design and Installation Practices and Procedures 1.2; 1.3; 1.4; 1.5; 1.6 Unit 105/005 1.4 2.1; 2.2; 2.5; 2.6; 2.7; 2.8; 2.9 3.1; 3.2; 3.3	1.1; 1.3; 1.4; 1.5; 1.6; 1.7	1.3; 1.4 2.1; 2.2; 2.4 3.1; 3.2; 3.3; 3.4	Unit 104/004: Understand Design and Installation Practices and Procedures 1.2; 4.3 Unit 105/005: Understand How to Plan and Oversee Electrical Work Activities 1.3; 1.4 2.1; 2.2; 2.5; 2.6; 2.7; 2.8; 2.9 3.1; 3.2; 3.3; 3.4; 3.5; 3.6; 3.7
Site restoration: <ul style="list-style-type: none"> ● Repair and restoration 		1.7		Unit 104/004 3.6; 3.7

INFORMATION

When planning, installing, commissioning and handing over electrical systems, a vast range of technical information is used. This information may include:

- statutory regulations
- non-statutory regulations
- codes of practice
- manufacturers' data and information
- wholesalers'/suppliers' data and information
- client and installation specifications
- information from employer organisation
- contract information, such as drawings, charts and graphs
- handover information.

We have covered statutory and non-statutory regulations and codes of practice in Book 1, Chapter 1.

Information from others

Manufacturers are responsible for providing a vast range of technical information, including:

- product specifications
- installation instructions
- user information
- safety certification.

INDUSTRY TIP

Note: 5357/8202 Unit 004 topic 1.1 was covered in Book 1, Chapter 3.

Product specifications

It is essential that equipment is fit for purpose. Before any equipment is purchased, the buyer must check the product specification. Many manufacturers will provide this information free of charge, either in the form of a printed catalogue or data sheet, or electronically as a web page or downloadable file.

In rare situations, manufacturers will only provide this information following the buyer making contact with a member of their sales team.

Product information will normally contain essential technical information. Depending on the product, this may include the following.

- Dimensions – essential when considering the location of equipment.
- Weight – essential when considering possible fixing methods or support.
- Loading – essential for determining circuit requirements, such as cable cross-sectional area, protective devices, maximum demands and power factor.
- Material – what the product is made of and whether the material will react with adjacent materials.
- Connection methods – many items or products may require specialist methods of connecting cables and terminating the conductors. This, in turn, affects the selection of cable used to supply the equipment and determines any specialist tools required.
- Output/performance – helps you determine whether the product will perform as required and actually do what is intended. This information may be in the form of a description or, in the case of lighting, photometric data.
- Finish – helps you determine whether the colour or material finish is suitable aesthetically and suitable for its intended location.
- Associated equipment – helps you determine whether you need to purchase any further products in order for the product to perform correctly and safely.
- Suitability for the environment – helps you determine whether the product has a suitable international protection (IP) code rating or protection for the intended environment.
- Temperature – helps you determine whether the product will pose a fire risk due to high operating temperatures, and whether the product is affected by the location's ambient temperature.

All of the above information must be carefully scrutinised before any product is purchased, as an incorrect product could be costly to replace or modify.

Installation instructions

All but the simplest products will have installation instructions. These are normally packed with the product but may be available from the manufacturer before the product is purchased. The installation instructions will normally provide key detail, such as suitable methods of fixing and how to connect the product.

A very important factor to note is that the manufacturer's instructions will normally supersede the requirements of **BS 7671**. An example of this could be that a manufacturer stipulates that a particular product should be protected by a 30 mA residual current device (RCD), yet BS 7671 may not require the particular product or circuit to be protected by an RCD. In this situation, the manufacturer's instructions should be followed over and above the requirements of BS 7671:

INDUSTRY TIP

Visit the manufacturer's website for product information and specifications. Manufacturers' websites have a large amount of product information but you may need to register to access this.

‘134.1.1 Good workmanship by one or more skilled or instructed persons and proper materials shall be used in the erection of the electrical installation. The installation of electrical equipment shall take account of manufacturers’ instructions.’

(BS 7671: 2018 (2022) Regulation 134.1.1, IET)

Installation instructions should ideally be researched and understood during the planning stage of any electrical installation in order to determine whether any further equipment is required.

User information

It is essential that installers of equipment pass on any user information provided by a manufacturer, to the client. This will also form a critical part of an operation and maintenance manual. What may seem a simple-to-use item to the installer may prove complicated to the end user. An example of this is a time switch. The installer may demonstrate the operation of the time switch to a client or user, but the user may quickly forget the verbal instructions.

User instructions or information will also contain information on any necessary spares or maintenance requirements for a particular product.

INDUSTRY TIP

Installation instructions should ideally be kept by the installer and passed on to the client, within any operation and maintenance manual for that installation, as they may contain essential commissioning and maintenance information required later.

IMPROVE YOUR ENGLISH



Remember, customers are unlikely to have the technical vocabulary you have, so be sure to communicate in layman’s terms (plain English), and provide written user information.

Safety certification

Any electrical product must carry a mark, label, or have associated certification supplied with it. This is to show that the product has been appropriately manufactured and tested to the product’s minimum safety standards. Caution must be exercised if you are asked to install a product that has no visible safety certification, if you are not sure of the product’s origin.

Wholesalers’/suppliers’ data and information

Many suppliers or wholesalers will pass on a manufacturer’s data, but many also produce their own paper-based and online catalogues. An electrical wholesaler will normally be able to provide verbal technical information about particular products. They will also have knowledge about any additional products that may be needed when installing any specific item of equipment.

Client and installation specification

Job specifications are compiled in a variety of ways depending on the size, complexity and contractual arrangement of a job. Generally, the specification for a project includes the following sections.

Preliminary information

This first section includes details of:

- the client
- the contract administrator

HEALTH AND SAFETY

If you have any concerns regarding electrical products and equipment and want to find out more information, visit the Electrical Safety First website.

INDUSTRY TIP

A big advantage of using wholesaler’s information is the ability to compare products from a range of manufacturers. There is, however, the disadvantage that the full specification for a product may not be published.

INDUSTRY TIP

JCT Minor Works is an example of the form of contract governing the project. You can find examples of these on the internet but it is important to ensure you are looking at UK versions.

- the form of contract governing the project (e.g. JCT Minor Works)
- further details, such as the anticipated overall contract period.

In order to give some indication of all the different trades involved, a construction programme may also be referred to in the preliminaries. In large multi-trade projects, the preliminaries also include the cost of site set-up and maintenance of items, such as welfare and storage cabins, given as a cost per day or per week.

Scope of works

The preliminaries are normally followed by a scope of works. This section determines the extent of the specification (i.e. the extent of what the contractor has to quote a price for). If the contract is agreed, the scope of works will become the extent of work to be carried out.

For example, a simplified scope of works may be:

‘The scope of works for this project is to install electrical systems within a new two-storey extension to an existing four-bedroom house. The works will include all wiring and containment systems for power, lighting and distribution. The works will not include the intruder alarm or fire-detection systems.’

Although this scope of works immediately eliminates the intruder alarm and fire-detection systems, there will be interfaces between systems that need to be defined. These are generally included in the particular specification and drawings that follow this section.

Specification of works

This section describes the particular works to be carried out. It gives as much detail as possible of what the designer and client require for that particular package of works. It may consist of simple descriptions or technical requirements laid down for the contractor (tenderer) to price and eventually work to. This could include details of every circuit required or details of the equipment that needs a supply, therefore leaving the design to the company tendering.

Materials and workmanship

Also known as the standard specification, this section is usually the same for all projects. It comprises a list of requirements in terms of workmanship and the selection of material grades and quality, along with any applicable British Standards or industry codes of practice.

Schedules

This section includes drawing issue sheets that indicate which drawings have been issued as part of the tender/contract. It also contains other schedules, such as equipment schedules, containing manufacturer selections, performance requirements, sizes and weights, and distribution board schedules.

Schedule of costs

This is usually the final document in the specification. The contractor (tenderer) has to complete it, specifying the cost of sections of work. Daywork rates also have to be specified in case unmeasured or urgent works need to be carried out that are not already contracted and cannot reasonably be priced or measured because of time pressures.

Information from employer organisation

During the planning and construction of an electrical installation, much information will be supplied to the site from your employer. This will include the client information and specification as detailed above, drawings as detailed below, and information relating to the administration of the organisation. Information from the employer organisation includes:

- copies of **purchase orders** so deliveries can be checked to ensure they are correct in quantity and type
- generic risk assessments and method statements. Many tasks that are carried out on site are repetitive and common to all construction sites. The employing organisation will have devised generic risk assessments and method statements which should require minimal revisions to suit the particular construction site. This saves a lot of time for the supervisor on the site, meaning that risk assessments and method statements only need to be completed from scratch for tasks that are unique to that site
- further health and safety information, such as Control of Substances Hazardous to Health (COSHH) data sheets
- regular updates and reports relating to labour, such as sickness or labour being diverted to other jobs.

KEY TERM

Purchase orders: Official orders that usually have an order number which links the purchased equipment to a specific contract. Purchase orders have a detailed list of materials that are required, to eliminate the risk of incorrect equipment being purchased.

Contract information

Numerous sets of drawings are produced to communicate information about individual systems or collections of systems within a project. They include:

- plans/layout drawings
- schematic (block) diagrams
- wiring diagrams
- circuit diagrams.

Other types of information, in the form of graphs and charts, which assist in the planning and construction of an electrical installation will be covered later in this chapter.

Drawings usually use British Standard symbols. However, in order to represent the wide variety of materials and equipment available, non-standard symbols may also be used. A legend or key explains them.

Plans or layout drawings are used to locate individual systems within the overall project and give an indication of the scale of the project. In addition, there may be drawings to show specific fixing, assembly and/or completion details. This is often the case where complex construction, lifting or use of a crane is required. These details may be provided in elevation, plan or both (covered in Book 1, Chapter 3). They will then become part of the contractor's method statement when the project goes into the construction phase.

Schematic (block) diagrams

Schematic (block) diagrams can serve many purposes, but are primarily provided to show the overall functionality of a system, including interfaces and operational requirements.

LEGEND	
	DISTRIBUTION BOARD
	FUSED CONNECTION UNIT WITH INDICATOR
	TWO-WAY SWITCH
	MULTI-GANG SWITCH
	CORD-OPERATED SWITCH
	13 A SOCKET OUTLET (2 DENOTES 2-GANG)

▲ Figure 4.1 Part of a drawing legend

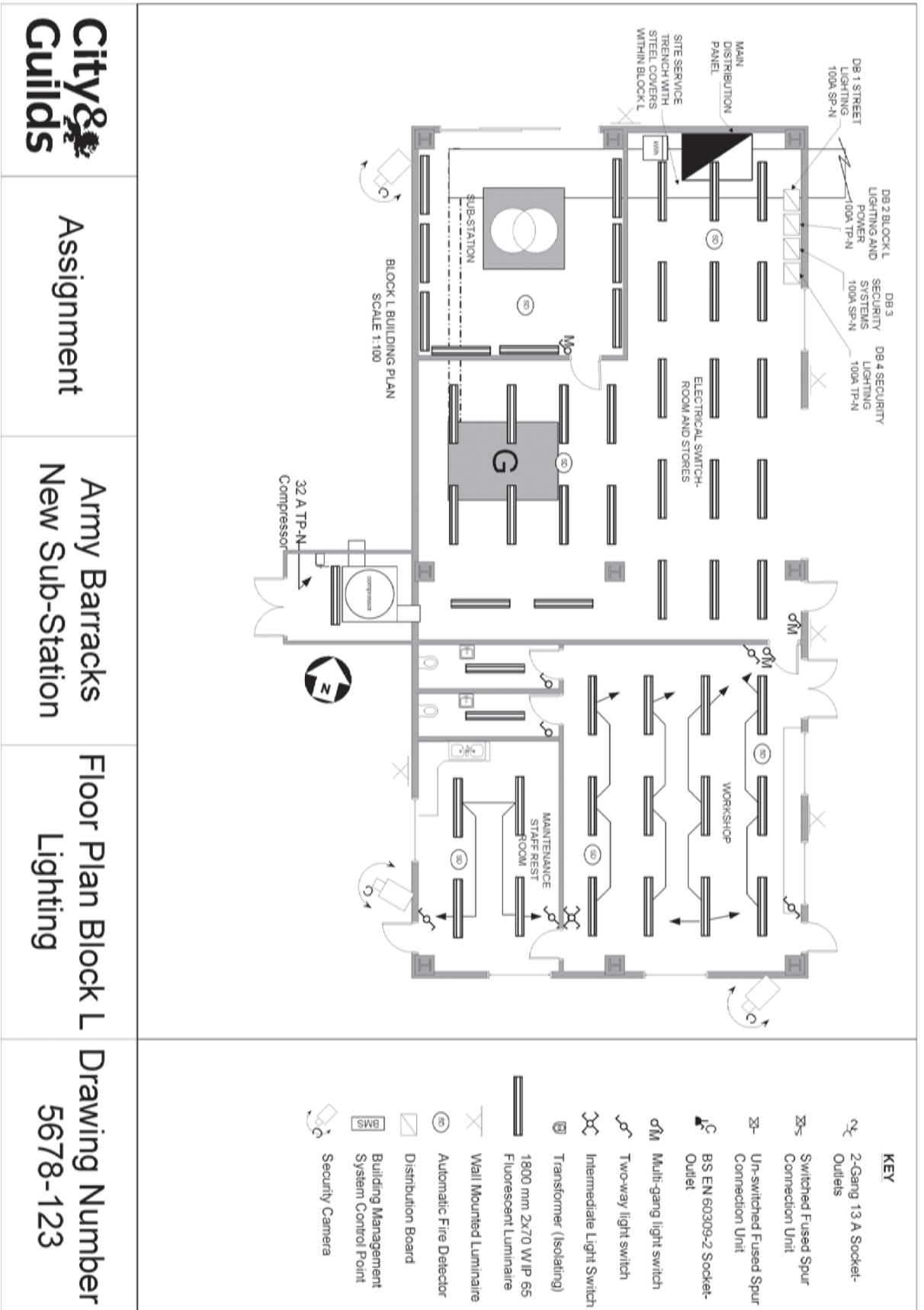

▲ Figure 4.2 Layout drawing

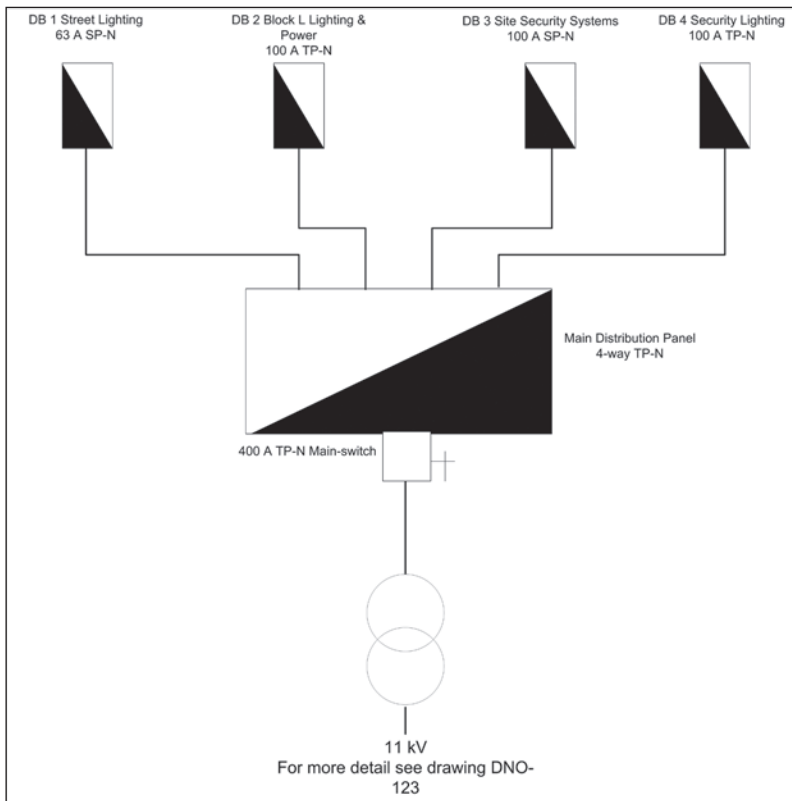

▲ Figure 4.3 Basic schematic drawing

Wiring diagrams

Wiring diagrams are generally provided to show in detail how a system or collection of systems is put together. They show locations, routing, the length of run and types of systems cabling. These types of diagrams are sometimes mistakenly referred to when it is actually a circuit diagram that is required.

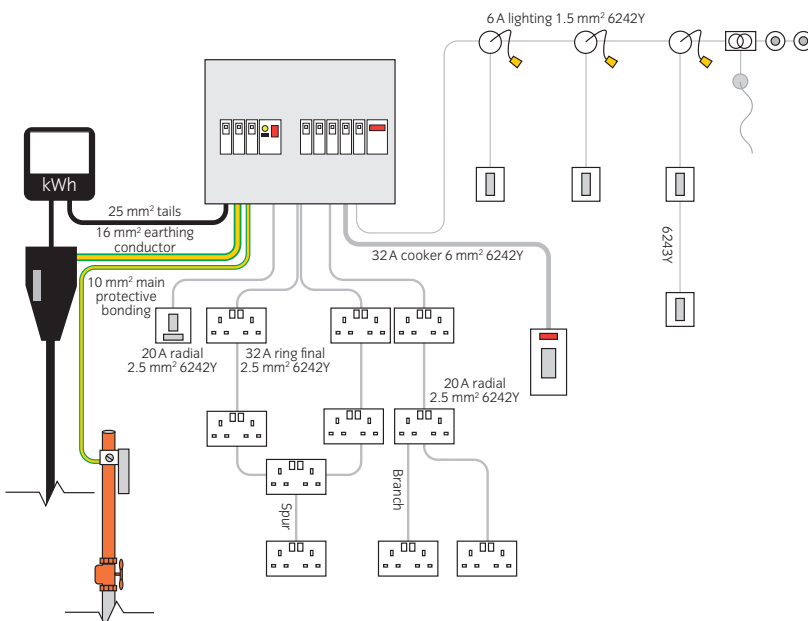

▲ Figure 4.4 Typical wiring drawing

Circuit diagrams

Circuit diagrams contain information on how circuits and systems operate. They can be provided as detailed layouts, although some information, such as length of run, may be omitted for clarity. In most instances, circuit diagrams are used for diagnostic purposes so that designers, installers and maintainers understand how their actions may influence a particular component or arrangement.

At different stages of work, the information on the drawings and diagrams is given in different levels of detail. The information becomes more detailed and accurate as the project develops.

ACTIVITY 

Figure 4.5 is a circuit diagram for a motor and its starter. Can you tell what type it is and how it works?



▲ Figure 4.5 Typical circuit diagram

Levels of drawing

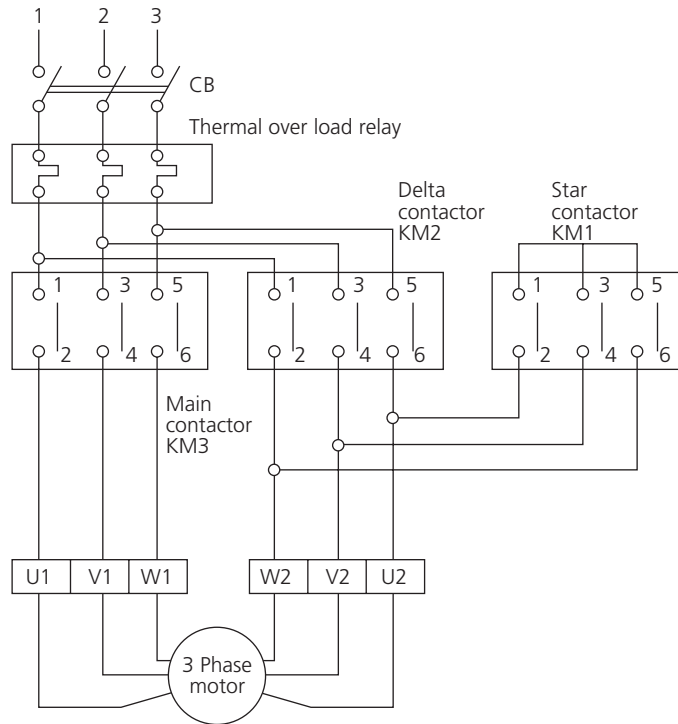
There are five main levels of drawing:

- sketch drawings/information
- design/tender drawings
- contract drawings
- working/construction drawings
- as fitted/installed drawings.

Sketch drawings

Sketch drawings are often hand-drawn sketches to help the designer demonstrate ideas and interpretations. They are usually drawn in the early stages of a project, when the scheme and designs are still fluid. They are therefore subject to change as every stakeholder is inputting to and potentially changing the scheme.

Sketch drawings are also often used at later stages of a project. Once the contractors have produced their working drawings, the designer may issue new sketch drawings for particular design details. These drawings become a contractual variation for that portion of the works and are recorded as a variation by the contract administrator.

Design/tender drawings









These are produced by a designer to convey the main design intent of the works. Although they are generally intended to be read in conjunction with the specification and other written documents, it is often easier to show the geographical scope of works by hatching out areas not covered on a drawing.

Design drawings are usually exchanged between designers initially to ensure coordination and then to communicate items for consideration under the Construction (Design and Management) Regulations (CDM), to other designers and stakeholders, including the client.

At the design stage of a project, the designer has a duty to eradicate hazards (whether notifiable under the CDM Regulations or not) where possible. A number of hazards may be unavoidable and these need to be pointed out to contractors.

Residual hazards should be identified on the drawings or schedules. The Health and Safety Executive (HSE) prefers residual hazards or hazard-reduction strategies to be indicated on drawings.

The design drawings are then put together with any stakeholder comments and issued with the specifications and schedules as tender drawings. Details of the residual hazards and hazard-reduction strategies on the drawings help contractors (tenderers) to understand any potential difficulties or additional requirements for completing the task safely. Allowances can then be incorporated into the preconstruction health and safety plan so that construction is carried out in a safe manner.

Area	DB reference	Drawing number								
Ground floor	DB-2	A-2011-3-R1	12	3	18	1	6	2	3	
First floor	DB-3	A-2011-4-R1	6	4	15	1	12	2	0	

▲ Figure 4.6 Sample take-off sheet

After the tender is awarded, the tender drawings usually form part of the contract on which the scope and detail of work has been priced. The tender drawings are usually re-issued, containing any contractual variations made during the tender period. They are then referred to as contract drawings.

On many smaller projects the general contractor usually refers to contract drawings as construction drawings (i.e. drawings of what the contractor tendered for and will install). However, in building services engineering, contractually there is a considerable difference between a design drawing or a briefly amended contract drawing and a construction/working drawing.

KEY TERM

Residual hazards:

Residual hazards are unavoidable hazards that will exist once the contract is complete and should be identified for the client to take reasonable precautions, such as working at height, working with electricity, etc. Although these tasks would not normally be undertaken by the client themselves, unless they had on-site maintenance teams, they are identified in operation and maintenance manuals, so that others are aware of the risks before work starts.

INDUSTRY TIP

During the tender procedure, the contractor will put together costs based on the material required. In order to gauge the amount of material efficiently, contractors will normally use a take-off sheet (for example, see Figure 4.6). The symbols used on the tender drawings are transferred to a take-off sheet and counted, giving the total for each piece of equipment required. We will cover take-off sheets in more detail later in this chapter.

Construction/working drawings

These are usually produced by the building services subcontractor. They are usually drawn at a very large scale and contain additional information not given on the previous drawings; for example, information on fixings, expansion measures, etc. This level of detail ensures installation exactly to the drawing. However, it is important that these drawings also reflect the overall design intent.

Installed/fitted drawings

Specialist shop drawings are a variant of construction drawings. They are normally produced so that manufacturers, suppliers and/or consultants can agree before manufacture takes place. In building services, installed/fitted drawings are normally produced by the subcontractor/installer. However, in structural engineering and certain architectural arrangements, they are provided by the structural engineer and architect respectively. This difference can cause problems and confusion.

Installed/fitted drawings should represent what has been installed, but also contain information on any residual hazards and risk-reduction strategies employed and instructions on how to clean, maintain or deconstruct the works if necessary. The drawings become part of a wider set of operation and maintenance manuals.

On completion of work which only involves electrical work, a specific **Operation and Maintenance (O&M) manual** should be provided for the electrical installation. This would include, depending on the extent of the work, key information such as:

- certification and test results
- circuit charts
- as-installed drawings
- what to do in the event of an emergency
- list of spare parts (lamps, fuses, types and ratings, etc.)
- instructions on use (timeclocks or other equipment)
- regular maintenance instructions (RCD test buttons, cleaning, etc.).

O&M manuals should also be updated or referred to when maintenance tasks are undertaken by electricians or additions made to the installation.

If maintained correctly, O&M manuals can save the client money. As a simple example, imagine that lamps need changing in one or two high bay light fittings. Getting to the lamps requires hiring special access equipment and once the fitting is accessed, it is discovered that the lamp type needed is not in stock and it will be three days until it is available.

If the O&M manual is referred to first, the lamp type can be looked up and ordered before the specialist access equipment is hired, meaning the access equipment is only needed once.

Maintained O&M manuals can also greatly assist in fault finding or spotting faults before they happen by referencing historical test results and seeing patterns of damage or failure.

Contracts

There are legal implications that you need to bear in mind when submitting a **tender** for work.

Contract law

English contract law regulates contracts in England and Wales. A contract generally forms when the contractor makes an offer and another person accepts it. Once a contract is made, it is enforceable in court.

If problems are to be avoided, the offer must be made clearly, in sufficient detail, including its terms and conditions. Obviously, it is preferable if the offer is made and accepted in writing.

Small works

Small works such as house rewires, or minor works such as additions or alterations, will usually be carried out under the contractor's own terms and conditions rather than the templates used for larger contracts.

The cost of the work is usually presented to the client in one of two ways:

- **as a quotation.** This is a fixed cost of the work. This is normally given where there are no hidden problems or issues that can create hidden additional costs. Where a quotation is given, the person providing the work must be confident that they have clearly understood the client's requirements and have undertaken a site survey.
- **as an estimate.** This is a method of providing a close as possible cost of works but with the understanding that there could be some factors that affect the cost. It is always a good idea to prepare the client for what the additional costs could be and for what reason. Nobody likes, and may be unwilling to pay for, a hugely inflated estimate.

When working out the cost of labour for small works, the cost must include **overheads**.

Overheads include items such as:

- business insurances such as public liability and tool/equipment theft
- office rent and costs of running the office, such as heating and lighting, telephones/internet etc.
- National Insurance contributions
- holiday pay
- general (i.e. not specific to the job) tools, plant and machinery
- transportation/vehicle costs such as MOT, servicing, insurance, tax
- salary/cost for support staff/services such as accountants, office staff, lawyers.

KEY TERM

Tender: An offer to carry out work for a certain amount of money, in accordance with a particular contract.

KEY TERM

Overheads are added to the labour costs as a percentage. Annual overheads should be calculated and divided into the expected hours worked annually to spread the cost of them over all works.



IMPROVE YOUR MATHS

A small organisation employs two electricians who are each paid £16 per hour. It is anticipated that annual overhead costs are expected to be £17 600.00 and the labour force work an average of 35 hours a week with 5 weeks holiday a year.

What would be their expected cost per hour to the client if 40% profit is added?

Annual hours worked:

$$35 \text{ hours} \times 2 \text{ persons} \times (52 \text{ weeks} - 5 \text{ weeks holiday}) = 3290 \text{ chargable hours}$$

Overheads per hour:

$$\frac{£17\,600}{3290} = £5.35 \text{ additional cost per hour}$$

So, cost of labour with overheads:

$$£16 + £5.35 = £21.35$$

Hourly rate with profit:

$$£21.35 + 40\% = £29.89 \text{ per hour}$$

So the charge out rate per hour would be £29.89.

Procurement methods

There are several methods the client can use to establish the right contractor for a project, some of which are explained below. The following factors need to be considered when deciding on the most suitable procurement method:

- budgets
- time to the start of the contract
- contract duration
- quality
- project limitations.

The client may already know which contractor they would like to use for their project, based on recommendations from others or having previously appointed them on another project. However, decisions must be made with value for money in mind. Is the price given by the preferred contractor competitive? The only way to know is by having other tenders to compare it with.

Open tendering

Where the client invites an offer for the contract from any organisation, this is referred to as open tendering. The advantage of this is that the process is fair as it isn't limited to preferred contractors. However, the client may have to choose a contractor whom they are not familiar with or who is less experienced. The client may have no alternative but to appoint a contractor based on their quotation and references from previous clients.

Two-stage tender

If the client would like to secure the services of a contractor early, without having all the relevant design information in place, they use a two-stage tender process. This would involve a contractor and client agreeing a cost based on the information provided so work can begin. At the second stage, when all

information is available, the contractor is able to negotiate a fixed price for completion of the work.

Preferred supplier (selective)

Clients with previous experience working on similar projects may have developed good working relationships with one or more contractors. Some of these contractors may be included on the client's list of preferred suppliers. From this list, the client may select several contractors and invite them to tender.

Negotiated tendering

Where a client has invited just one contractor to price for a project, this is referred to as negotiated tendering. Before building contracts are signed, the client usually negotiates the best price for the work. This may not be the best method for a client that needs to prove value for money as they have no other costs with which to compare.

Tender procedure for larger works

When a company receives an invitation to tender for a particular contract, the normal process to follow would be:









- record all documentation
- gather information to form the estimate
- determine prime costs
- determine provisional sum
- make final tender.

Record all documentation

All documents received in the invitation will be recorded and checked against the list of documents supplied, which should also be included. This ensures that all relevant documents are present and the most up-to-date versions of drawings are used. If, by mistake, an older version of drawings is used, this will reflect in the overall cost submitted.

Gather information to form the estimate

All documents and drawings will be carefully scrutinised and lists of materials will be written. These may be regular materials, such as switches and socket outlets, that are listed on a **take-off sheet**.

Area	DB reference	Drawing number								
Ground floor	DB-2	A-2011-3-R1	12	3	18	1	6	2	3	
First floor	DB-3	A-2011-4-R1	6	4	15	1	12	2	0	

▲ Figure 4.7 Sample take-off sheet

The sample take-off sheet shows the number of particular items needed for a particular area of the installation. The symbols would be used from the drawing, to minimise any confusion, and the specification would be checked for any specific manufacturer or finish required. At the bottom of the sheet,

KEY TERM

Take-off sheet: A list detailing the number and scope of items needed per area of installation.

KEY TERMS

Bill of quantities: A pre-prepared list of materials usually created by a quantity surveyor; replaces the take-off sheet.

Schedule of rates: A document that lists a labour/time cost for installing and connecting an individual item of equipment. Examples may be £2.50 to fix a ceiling rose securely to a plaster ceiling and £1.50 to connect the cable to it. Running the cable to the ceiling rose could be charged at a rate of £2.00 per metre.

INDUSTRY TIP

It is always wise, if possible, to visit the site at this point, to see whether there are any issues that may affect the installation process. For example, issues such as space constraints, giving rise to delivery and storage problems, would require a lot of labour time spent moving materials around from storage to site.

totals would indicate the quantity of each product required. The advantage of showing the quantity of items per area is that, should a contract be won, this information can be used to order materials at suitable installation stages.

Other major items of specialist equipment, such as large motors and generators, will be put out for quotation to major suppliers or manufacturers.

In some situations the client may provide a **bill of quantities**. This would be a ready-made list of specific materials and would normally be made by a quantity surveyor. This would replace the take-off sheet. Once the material costs, including any specialist plant, have been obtained, the cost estimate can be calculated. This will involve total material costs and estimated labour costs against each specific area. In some instances, a **schedule of rates** may be used to assist in this process.

Prime cost

Prime cost is an allowance for the supply of a particular item of equipment where the equipment has been specified by the client. For example, if the client specifically requires a particular type of decorative chandelier to be installed, the prime cost would be for the contractor to purchase the chandelier. This would not include the cost of installation. In some circumstances, prime cost may be a cost for supplying a service by a nominated subcontractor specified by the client. An example of this would be the prime cost for a specialist subcontractor to create and install a particular piece of decorative artwork, such as a statue or feature within a building.

Provisional sum

This is a sum of money that will cover the work required to install a particular item of equipment, when the actual cost is yet unknown. An example could be the installation of a decorative chandelier where the detail of its full size or weight is not yet known. In this case a provisional sum would be given to the client, which can be renegotiated later in the contract.

Final tender

Once all the costs of labour and materials, including prime costs and provisional sums, are determined, the company overheads will then be added to make the final tender. Overheads include the hidden costs of a business, such as the costs of:

- van insurances
- office staff
- holiday pay
- National Insurance contributions.

Overheads include many factors, but the list above gives some examples of what should be allowed for.

Finally, the tender is completed by a senior manager, using the benefit of their own experience to account for further costs, such as profit and other considerations that may arise. This involves a very careful balancing act to ensure that the company benefits from the work while keeping the overall cost competitive.

Alterations to a tender

If a tender is successful, a contract will be agreed and signed, based on the work contained in the tender and the agreed price. Rarely will an installation follow the tender exactly, as the various factors affecting the overall installation are likely to change during the work. Examples of this could be socket outlets needing to be re-sited, as a radiator needs to be fitted in a particular location and this not having been anticipated.

Where these instances occur, the installer must obtain a **variation order**. At this stage, an additional sum for the alterations may be agreed or the work could be undertaken on a rate per day. Day work sheets will be used to record the additional work and, at various points in the contract, the costs of these additional jobs will be agreed. Some major contracts require the day rates to be agreed prior to work starting.

Contract progress

The progress of a contract is set and monitored using a variety of tools, such as critical path networks and bar charts. These are covered in detail starting on page 257.

Should a contract fall behind expected progress, due to factors under the control of the electrical subcontractor, it is likely that penalty clauses would take effect. These clauses are imposed as part of a contract agreement to ensure timely completion. If completion is delayed, the client may need compensating due to loss of facilities. These penalties are set, normally at a single day rate, at the point where contracts are agreed. The longer the delay in completion, the larger the penalty imposed. For this reason, use of tools, such as critical path networks, can assist in avoiding delays.

Customer service principles

Good customer service is about exceeding the customers' expectations and providing a service that will make them want to recommend your organisation to others, as well of course use you again.

There are several points for employers and employees to consider that lead to an organisation providing good customer service. These include the following.

- Being helpful even if a request is beyond your abilities. Saying 'that isn't my job' to a request is not helpful. Better responses are 'I can find out for you' or 'Have you spoken to this person about that?'
- Asking for feedback and acting on it. Everyone likes to receive good feedback, but negative feedback is useful too. It gives you something to aim for to make your service better. Accept negative feedback and act on it!
- Knowing your products and work. It helps to know your subject, so you are always in a position to offer the client the right product or service.

INDUSTRY TIP

Architects may also request a change to original plans, by issuing an AI, which stands for architect's instruction.

KEY TERM

Variation order: A declared change to the original contract.

INDUSTRY TIP

Companies that have been accredited **ISO 9000** have demonstrated that they:

- perform effectively, using management systems
- meet regulatory requirements
- work to ensure they meet their clients' needs.

KEY TERM

ISO 9000: A quality standard for management systems to ensure that organisations meet the needs of their clients while meeting all regulations.

- Giving a great first impression. This applies to all persons at each stage of the work as each person that is new to the client is helping them to form an impression of your organisation.
- Planning and informing. Nobody likes inconvenience and unpleasant surprises. Planning work properly means you know what is coming up and you can give the client plenty of notice regarding occurrences such as power shutdowns or times where there will be limited access to particular areas, etc.
- Being proactive, not reactive. Get to know your client and act on situations before they arise as a problem. If you only react to something when the client has complained about it, it may be too late.

PLANNING THE WORK ON SITE

In the previous section we looked at preparations prior to starting work and the information needed to price or tender the work. When on site, a large amount of planning is required to keep the site efficient and safe.

The work environment

With the site management team taking care of the working environment, it is normally left to either the subcontractor or their nominated team leader to make the necessary preparations for the work activities that they will perform during the project.

When an installation tender is submitted, it is based on getting it right first time and therefore making a profit. Every error, change or omission, no matter how small, has an impact on the final profit. Correct planning and preparation are intended to ensure that the work is performed quickly and correctly first time, every time.

INDUSTRY TIP

The preparation work is essential to performing the task correctly, cost effectively and, of course, safely. It is worth noting the five 'P's:

- Proper
- Planning
- Prevents
- Poor
- Performance.

VALUES AND BEHAVIOURS

'Fail to plan, plan to fail.' This is very true in electrical installation work.

Site services

Before work begins on a construction site, the site needs to be ready for a variety of activities and persons, including:

- service provision
- ventilation provision
- waste disposal procedures
- storage facilities
- health, safety and welfare requirements
- access and egress.

Service provision

Services are required for a construction site to function, including:

- electricity supplies
- wholesome water and other water sources
- waste-water systems
- fuel sources.

Electricity supplies

Nearly all construction sites will require an electricity supply for power tools and lighting, as well as for administration and welfare blocks. Where the site is a refurbishment project, the existing electricity supply may be used but careful consideration must be given to the requirements in Section 704 of **BS 7671** (Construction and demolition site installations).

As most major construction sites which use the existing electricity supply cannot guarantee the reliable connection of the main protective bonding conductor during refurbishment work, the site supply may be converted to a TT earthing arrangement during the site work. This means that the earthing for the construction site will rely on an earth electrode. An assessment must also be made as to whether the existing supply is suitably rated for the intended load during construction (see the considerations for load, below). If the construction site is new or remote, then a new supply must be requested, or a generator obtained. In both cases, an assessment of the demand needs to be made. This is difficult as the total load will change regularly. A good way to gauge the overall load is to assess the overall kVA (kilo volt-amperes), taking into consideration:

- the quantity and rating of site transformers used to provide 110 V supplies
- charging points for battery-operated equipment
- total temporary lighting loads
- large plant and machinery, such as cranes, welders, bench saws, etc.

If the site is considerable in size, a three-phase supply may be required. If a new supply is required, an application needs to be made to the local distribution network operator (DNO).

Wholesome water and other water sources

Water is essential on site. Wholesome water is drinking water and is necessary for the welfare of those on site. Other reasons for requiring a water source are:

- mixing cement or other materials
- washing or showering
- cleaning equipment, roads or structures
- dealing with hazards, dust or chemicals.

In remote locations, **water bowzers** could be used to provide a water supply if mains water is not available. Water should not be drawn from rivers or lakes unless specific permission is granted from the Environment Agency.

INDUSTRY TIP

Any application to the DNO needs to be made well in advance of work commencing, as arranging and installing a new electricity supply can be a very lengthy process.

INDUSTRY TIP

All generators have a rated output measured in kVA not kW. Generators can be seriously overloaded if this is not considered.

KEY TERM

Water bowser: A transportable water tank or tanker.

KEY TERMS

Soakaway: A system where surface water or water from guttering is channelled into an area of ground that has been suitably prepared to allow the water to disperse in the ground without causing flood or damp issues.

Blackwater: Water that is contaminated to the point of no use and must be treated at a waste-water treatment facility. Sewage is classed as blackwater.

Waste-water systems

Waste water needs to be considered along with water supplies as mentioned above. Waste-water systems need to be looked at in two ways. Firstly, any surface water from rainfall needs to be diverted into local watercourses or **soakaways**. Secondly, **blackwater** needs to be discharged into either main sewers or septic tanks.

VALUES AND BEHAVIOURS

Water efficiency should also be considered on any project. Visit the Environment Agency's website for more information on sustainability and energy reduction, at: www.gov.uk/government/organisations/environment-agency

Fuel sources

Larger construction sites will need to consider storage of fuels, such as diesel, for plant, vehicles and generators.

Ventilation provision

Ventilation needs to be considered in situations such as confined locations, tunnels, underground works or, more generally, in large buildings. Ventilation should also be considered for specific tasks which involve a large amount of dust, where the area is to be sealed off.

Ventilation may also be required for particular items of equipment that are vulnerable to dust contamination. The most common method of ventilating areas is by a forced clean air system, where clean air is forced by fans through ducting into the area and, in many cases, extraction fans then remove stale air from the location.

Other locations and equipment may adopt a system where air is forced into an area or enclosure, creating a high pressure. This high pressure minimises contamination by keeping out dust and contamination from lower pressure areas.

Waste disposal procedures

Careful consideration needs to be given to areas set aside for waste storage and collection. As waste is normally collected by large vehicles, easy access is one of the most important factors that affects the location of waste storage. Methods of separating waste for recycling, or hazardous waste, are covered in detail in Book 1, Chapter 1, pages 12–13.

Construction sites for high-rise buildings require methods of moving waste from upper floor levels to waste collection points at ground level. This is normally done by rubbish chutes, which are flexible ducts that allow waste to fall safely, directly into a collection point.

Storage facilities

Good storage facilities must be provided for plant, machinery and materials in order to minimise:

- theft
- damage
- congestion.

A secure lockable area, such as a storage container, is a good method of reducing theft from sites as well as reducing the likelihood of damage from weather or general site activities. If a good secure area is not set aside for storage, materials left around a site can become a hazard by potentially blocking escape routes or becoming obstacles to others trying to carry out their tasks. As well as being a safety hazard, poor storage also becomes inefficient as it is more likely that materials will become damaged or lost, or time will be wasted moving the materials out of the way.

When locating storage facilities, consideration should be given to:

- ease of delivery of the storage container
- ease of delivery of the equipment to be stored
- minimising distances from storage to point of use
- keeping emergency routes clear
- keeping traffic areas clear, e.g. lorry turning circles
- avoiding any location that is likely to be built on as part of the project or where services are to be laid
- not blocking services or systems, e.g. avoiding placing a container next to a wall with a flue or vent
- not blocking daylight from windows
- presence of overhead cables
- security.

Health, safety and welfare requirements

All construction sites, regardless of their size, must provide basic amenities, such as:

- toilet facilities
- washing facilities (hot and cold water)
- first-aid facilities
- changing rooms or lockers.

On larger construction sites, rest areas which provide shelter from the weather should also be provided. Showers must be provided on sites where tasks involve working with chemicals or hazardous materials. When considering welfare facilities, the Health and Safety Executive (HSE) has produced an order of preference for the provision of welfare facilities, dependent on the nature of the construction.

INDUSTRY TIP

For more information on required welfare facilities, research the HSE website.

Planning for materials and equipment

The most significant cost of any installation work is that of the labour required; however, a close second is that of the materials to be used. When confronted with a new project, it is essential to understand what materials will be required to complete the work. To help understand this, the installation team needs a number of documents.

The technical specification

The **technical specification** is the most important document as it has been used as the basis of the agreed contract that is being followed. However, it is important to ensure that all variations and departures are also documented and have been included. The technical specification will indicate any client's preferred manufacturers for certain components, or even desired finishes that need to be complied with.

The technical specification will also detail what other standards are to be complied with, as well as extra options required. For example, the client may require a minimum of 25% extra capacity on every distribution board. This would have an impact on the equipment ordered. For example, if a distribution board was specified as providing a supply to ten circuits, then typically a 16-way distribution board would be required to meet the client's request.

Other key information that is normally contained within the technical specification is the detail of the building construction. The technical specification will detail the construction of the wall, along with the details of the floor, wall and ceilings finishes. This information is essential when planning an electrical installation, as it helps to identify where and how the wiring can be installed. If an installation team were not aware that the floor through which they were expecting to run cables was actually a concrete slab, then this would create a lot of problems on site and result in a significant delay if not discovered quickly.

It is also important to consider other factors, such as the purpose of the building, who will be using it and other environmental factors. These may be detailed within the technical specification but, if not, then the design team need to establish these external influences.

Materials list

Trying to keep track of all the materials required, just by marking up drawings, can become very complicated, especially on larger projects. Therefore, it is common practice to use a series of documents generically called the materials list.

Materials lists will contain different information, depending on company procedures and requirements; however, there are always some common aspects and these include:

- the index number – a simple numerical identifier that makes it easier to track items on the materials list
- the description – a brief description of the item to enable it to be identified

KEY TERM

Technical specification: A technical document giving concise details of the client's wishes and expectations.

INDUSTRY TIP

Appendix 5 of **BS 7671** is dedicated to external influences that may need to be accounted for when detailing an installation.

- the unit of measure – used to clarify what the quantities are measured in, e.g. litres, metres or individual items
- the quantity – how many of the items are required.

Other information that may appear on a materials list includes:

- cost – how much each item costs
- supplier – who is the current supplier or who stocks the item
- catalogue code – where a specific item must be used, this is the supplier's catalogue number.

Materials lists can be arranged in two different formats, depending on who is to use the information:

- Total counts of materials for buyers
- Staged counts for the installation team.

Electrical buyers may want to know the total counts of materials so that they can exploit a higher level of buying power. For example, if an electrical buyer needs to order several thousand components from the same supplier, then they will be able to request a bigger discount.

An installation team will require the materials list to be broken down, to show what they will need in each part of the installation. This enables them to undertake stock control and make sure that the correct quantities of materials are in place at the right time, reducing waste and other losses, such as delays, and avoiding **short shipments**.

Working from materials lists can enable bulk purchasing power to be used to gain a lower cost. It can also be used to set delivery schedules with the suppliers, using **just in time** systems. This means that there is less requirement for storage of materials on site and less chance of materials being lost, damaged or even stolen.

Tools and equipment

With the design completed, risk assessments performed, with method statements produced and all materials identified and ordered, the final stage of the preconstruction preparation is about ensuring that the correct tools are available, safe and in good working condition. In reviewing the site drawings, it will also have become apparent what access, equipment and working platforms will be required to perform the installation work safely.

The Provision and Use of Work Equipment Regulations (PUWER) states under Regulation 4 that:

- (1) Every employer shall ensure that work equipment is so constructed or adapted as to be suitable for the purpose for which it is used or provided.
- (2) In selecting work equipment, every employer shall have regard to the working conditions and to the risks to the health and safety of persons which exist in the premises or undertaking in which that work equipment is to be used and any additional risk posed by the use of that work equipment.'

KEY TERMS

Electrical buyer: The person who places the purchase orders with suppliers for electrical equipment. They are often required to source and negotiate deals to secure the best price and delivery for a wide selection of electrical accessories and components. Big discounts can be given by the supplier if the electrical buyer can place large orders.

Short shipments: Occur when the supplier delivers an incomplete order. There are normally items on the original order still to be delivered, or the quantity is short and the balance is yet to come.

Just in time: A site term used to describe an approach to stock/goods control; a large-quantity order is placed with a supplier, with agreement on a staged delivery. This means that the total order is placed at the start, to take advantage of quantity discounts, but the supplier stores the materials and only delivers the required quantity at the agreed times throughout the project.

INDUSTRY TIP

A guide to the Provision and Use of Work Equipment Regulations (PUWER) can be accessed via the HSE website.

HEALTH AND SAFETY

A clear warning and identification should be placed on any piece of equipment that is not safe to use, so that everyone is made aware. Defective equipment should not be stored in the same location as serviceable equipment.

All tools must be checked at this point, to make sure that they are safe to be used. Any defective tools or equipment must be replaced immediately. It is important also to confirm that the correct tools and equipment for the environment and task have been selected. The locations where tools and equipment are to be used and stored must be identified and an assessment must be made with regards to the locations' suitability.

In the event that any tool or piece of equipment is damaged, this needs to be reported and the tool taken out of service immediately. This is in accordance with Regulation 5 of PUWER, which states:

'(1) Every employer shall ensure that work equipment is maintained in an efficient state, in efficient working order and in good repair.

(2) Every employer shall ensure that where any machinery has a maintenance log, the log is kept up to date.'

Site meetings

From concept right through to completion, the key success factor to most projects is keeping the relevant trades and contractors informed and giving them a platform for their input. Site meetings are one way in which this can be achieved. The name 'site meeting' is sometimes misleading as these meetings do not always happen at the construction site. In fact, on many large contracts, the site meeting often starts in company boardrooms, where essential decisions have to be made to get the project started.

IMPROVE YOUR ENGLISH



Site meetings are key to keeping all involved up to date and 'on the same page'. Meetings provide an opportunity to communicate ideas or raise concerns. Having the confidence and skills to clearly articulate yourself is important to ensuring your input is heard and valued.

Once the construction site has been established, the site meetings take on a slightly different role as they are more about coordinating the activities being performed on the site. At this point the meetings are normally chaired by the main contractor. It is the main contractor who is ultimately responsible for what happens on a construction site and so they often use the meeting to ensure that all parties are working together and that the project is progressing to plan. It is through these meetings that the project progress can be established and monitored. Each meeting is minuted and a formal progress report is issued to the client and the architect. These reports are also used to confirm when the build has reached a critical point and that the next phase of work can be commenced.

One of the many other benefits of having regular communication between all the trades on a construction site is the ability to ensure that there is coordination among all affected trades on key items. The standard build of an electrical installation needs to happen at key points in the progress of the project. First fix must happen after the walls are erected but before they are plastered. This means that the installation team needs cooperation from both builders and plasterers. The site meeting can provide a means for achieving this.

Site induction training

On first arriving on a new site, every person must undertake site induction training. This is intended to ensure that everyone on the worksite is aware of key health and safety points, including:

- emergency evacuation procedures
- fire-alarm call-point locations
- first-aid locations and first-aiders
- site policies and procedures
- locations of welfare facilities
- locations of toilets and hygiene facilities
- details of restricted access locations
- site waste-disposal policies
- locations of storage provisions for each trade or company.

The purpose of site induction training is to ensure that everyone is aware of the basic safety and site requirements, so attendance is often mandatory, even if you have worked for the main contractor before. A record of attendance is kept, which is normally stored in the site safety file.

Pre-existing damage

It is important to remember that electrical installation work does not just happen on construction sites where the building work is being performed for the first time. Electrical installation work may be needed at any point during a building's lifetime. For example, additional work may be needed when:

- there is a change of use of the building
- there is a change of building occupancy
- there is an extension to the building
- there is an alteration within the building
- there has been damage caused by, for example, fire or flood.

In these circumstances, you need to consider the potential damage that you could cause to your client's belongings. This could include damage to:

- the actual building, in terms of its structure
- interior decorations, such as wallpaper
- furniture and fittings
- carpets and flooring
- doors, windows and their frames.

BS 7671: 2018 (2022) The IET Wiring Regulations, 18th Edition Regulation 132.16 states:

'No addition or alteration, temporary or permanent, shall be made to an existing installation, unless it has been ascertained that the rating and the condition of any existing equipment, including that of the distributor, will be adequate for the altered circumstances. Furthermore, the earthing and bonding arrangements, if necessary for the protective measure applied for the safety of the addition or alteration, shall be adequate.'

HEALTH AND SAFETY

Site induction training is designed to ensure the safety of everyone on site and should be attended by all involved in the installation.

VALUES AND BEHAVIOURS

Imagine you owned a brand new car and you took it to the garage for its service. You would not be happy if, when you collected your car, the seats were covered in grease and oil stains and the front wings were covered in scratches from the mechanic's tools. The same considerations exist with regards to people's homes and to commercial premises.

This means that the existing installation must undergo assessment before any work is carried out, and it is a good idea to ensure that this is done before the extent of the work has been agreed and a price set.

The pre-work survey

The pre-work survey is intended to establish if the current installation can support the proposed changes and to check the condition of the existing installation, including identifying any damage already present. It is therefore important to record the results of the inspection, noting whether everything is in good condition.

To perform a pre-work survey, an installer will need a test instrument to perform tests, such as:

- earth fault loop impedence
- prospective fault current
- polarity of supply.

INDUSTRY TIP

See Chapter 7 of this book, Figure 7.5, for an example of an Electrical Installation Condition Report (EICR).

They will also need a torch, a set of insulated screwdrivers, a camera and something to record their findings on. One document that can be used for this is the Electrical Installation Condition Report (EICR) complete with a Condition Report Inspection Schedule (CRIS). It is important to understand, though, that this is not the same as performing a periodic inspection of the system but is simply to confirm the current condition of the installation, prior to changes.

The purpose of the camera is to make sure that there is documented proof of the condition prior to work commencing, should any problems or damage be identified. Simply taking a picture of the damage or problem can often help to clarify with the client what work will be undertaken. It is important to focus on the area where the work is going to be performed, including access routes.

If a pre-work survey is not conducted and the client notices some damage to their property after the work is finished, they may blame the installer for the damage and expect it to be corrected, with the installer footing the bill, which can be expensive. If, however, a pre-work survey has been performed, this may prove that the installer is not responsible for the damage.

As well as checking the condition of the electrical installation, it is important to check the surrounding areas and access routes for existing damage, rather like checking a hire car before driving it away.

Checking for existing damage is important as it:

- may identify challenges for the installer that had not been noticed before
- can reveal potential problems within the installation
- can identify where further work may be required.

Table 4.2 shows some of the things that should be checked for outside of the installation.

▼ Table 4.2 Pre-installation checks

Damage to:	Look for:
the actual building in terms of its structure	<ul style="list-style-type: none"> ● cracks along walls and ceilings ● dents in walls and ceilings ● holes in walls and ceilings ● loose fittings caused by crumbling plaster.
decorations, such as wallpaper	<ul style="list-style-type: none"> ● torn or peeling wallpaper ● marks on wallpaper or painted walls ● chips to paintwork or other marks.
furniture and fittings	<ul style="list-style-type: none"> ● cuts, holes or burns on furniture ● water marks on wooden surfaces ● heat rings on wooden surfaces.
carpets and flooring	<ul style="list-style-type: none"> ● dirty marks ● stains from spills or paint ● holes, burns or cuts ● scratches on wooden floors.
doors, windows and their frames	<ul style="list-style-type: none"> ● broken or chipped glass ● broken handles or locks ● chips or cracks to woodwork ● existing holes or notches.

What to do if damage is discovered

If damage is discovered during the pre-work survey, then the installer simply needs to make a note of the damage and take a quick photograph. Then, before starting work, the installer should speak to the client and point out the damage identified.

It is always important to make the client aware that the damage is only being identified to confirm they are already aware of its existence. If damage is discovered during work, then it is important again for the installer to record it and, where possible, take a photograph of the damage. If the damage is severe, then the client also needs to be made aware of the damage as soon as possible. This may mean that work has to stop, depending on the severity of the damage. This typically includes damage to structural elements, such as floor joists that were not visible before the work commenced.

Another type of damage that might be identified at this time, rather than earlier, is damage to wiring caused by overheating conductors or rodents chewing cables. In this instance it is important to show this to the client as soon as is practicable, as it may require further action that is beyond the scope of the planned work.

HEALTH AND SAFETY

Damaged wiring presents an immediate risk of electric shock. It must be made safe immediately and this may involve safely isolating the circuit and getting guidance from the client as to the remedial action they require. This often will require the client to speak with the company employing the installer, to agree a contract detailing additional work to be performed and its cost.

VALUES AND BEHAVIOURS

When informing customers of damage identified pre-installation, a lot of tact is often required, as the installer will potentially be pointing out problems with the client's property.

Protecting the property

After checking for existing damage prior to starting work, it is just as important to make sure that damage does not occur as the work is being carried out.

VALUES AND BEHAVIOURS

Where the work areas house small items of valuable property belonging to the client, it is a good idea to ask the client if they are happy to remove them so that they do not get damaged. Doing this removes the risk of the items being damaged, either during the work process or even as they are being moved by the installer.

INDUSTRY TIP

For more information on hazardous locations, visit the Health and Safety Executive's website.

Precautions must be taken to prevent damage from occurring whenever possible. To prevent damage to key items, some simple measures can be taken, such as:

- wearing overshoes to protect the client's carpets
- using floor matting to protect the client's flooring
- laying dust sheets to protect the client's furnishings
- erecting hoardings to protect windows and other areas of the property.

Decommissioning systems

When working in existing installations and undertaking work such as re-wires of buildings or circuits, the existing wiring and systems will need to be decommissioned, disposed of and, where necessary, parts of the building need to be made good.

These situations require detailed planning with the following, amongst other factors, needing consideration:

- will the new system be wired whilst the existing system is operational to maintain a supply
- what damage will need making good when the old systems are removed
- will work involve working around existing live systems and what precautions are needed
- reviewing operation and maintenance (O&M) manuals for any information required for safe decommissioning and disposal
- can existing routes, holes in the building, etc., be utilised to minimise further damage.

Detailed planning could save a lot of time and delays. In addition, it is often the decommissioning and removal of old systems that gets overlooked when estimating the cost of the work as it is too easy to focus on the new, rather than the time and effort needed to remove the old systems. This time and effort can be considerable and therefore costly.

Managing a safe site

In Book 1, Chapter 1, we covered in detail the methods used to keep sites safe. These included risk assessment, method statements and the statutory and non-statutory regulations that must be complied with.

Some sites are classed as hazardous sites, needing much greater care and specific risk assessments and method statements. These sites could include mines, petro-chemical storage areas and petrol garages, and explosive environments. Many of these locations are zoned depending on the level of danger or proximity to hazardous materials. Careful consideration is needed regarding the types of plant and machinery used in these locations as many may need to have, for example, flame-proof enclosures.

Special training is always a requirement before working on these types of site.

Managing a standard site safely requires different types of information as well as trained personnel.

Information needed to promote health and safety

The principal contractor has responsibilities to secure health and safety on site. This involves gathering information from the contract documents, including the design specifications, and all stakeholders, including:

- the client
- the design team
- other contractors on site
- specialist contractors and consultants
- trade and contractor organisations
- equipment and material suppliers.

Additional information will also be required on special features, such as:

- asbestos or other contaminants
- overhead power lines and underground services
- unusual ground conditions
- public rights of way across the site
- nearby schools, footpaths, roads or railways
- other activities going on at the site.

Managing safety on site before work starts

The principal contractor must assess access to the work site, arrange a programme of work and ensure that access arrangements are suitable for subcontractors to use. Any specialist contractors who need to work in isolation for safety reasons (e.g. with chemicals or radio isotopes) should be consulted and appropriate time allowed in the programme of work for them to carry out their duties safely. In conjunction with the subcontractors, the principal contractor must ensure that:

- all relevant working methods have been identified and time allowed for them to be undertaken
- all equipment used on site is compatible with other operations on site at the time allocated on the programme
- all potential hazards have been considered and as many as possible eliminated (e.g. painting does not need to be done at height if materials are brought to site already finished)
- all remaining risks are assessed, decisions are taken on how to control them and procedures are put in place
- everyone working on site is competent and has the right equipment to do their work
- appropriate work methods are agreed
- site deliveries are arranged at the best times to minimise safety risks to the public, taking into account neighbourhood circumstances, such as school drop-off and pick-up times
- emergency and rescue procedures for the site are in place, including any additional training required (e.g. harness rescue from height).

Ensuring workers' competence and awareness of risks

Those who supervise the work must be adequately trained, have suitable experience and have access to additional guidance to ensure they are competent. They must ensure that agreed work methods are put into practice.

Workers must be competent to carry out their work, so their trade certificates and Construction Skills Certification Scheme (CSCS) card or trade skill card should be checked. They must have suitable equipment to carry out their work. The Electrotechnical Certification Scheme (ECS) card is one example of a trade card (see page 460).

It is also important to ensure that subcontractors on site have adequate supervision and that their operatives are trained and competent in the tasks they are employed to carry out.

Before any worker starts work on site, it is important to make sure they:

- understand the general risks on the site
- are familiar with the tasks they are being employed to carry out
- are aware of any additional hazards or increased risk due to local conditions.

This information will usually be set out in the workers' method statement, worked through at the site induction and checked on a regular basis, with formal follow-up in toolbox talks.

HEALTH AND SAFETY

Usually, the greater the risk during construction, the greater the degree of control and supervision required.

Health and safety during the construction phase

During the construction phase, there must be adequate management and supervision on site to ensure all operations are carried out as safely as possible. During construction, this includes a wide range of risks. These include risks from moving goods, working at height or in confined spaces or with electricity or dangerous substances, or even risks to the public.

It is necessary to ensure that all measures put in place are relevant and effective. It is therefore important to review procedures on a regular basis to make sure they continue to be relevant and effective as time goes by and the nature of work on site changes.

Monitoring of health and safety on site must be carried out by a trained and competent person, who is able to review the safety procedures in the context of all the changes in work and circumstances on site. The review process must also check that contractors and subcontractors are working safely and in line with their method statements. Action must be taken to deal with those who fail to work safely. The review should also consider whether similar problems reoccur, find out why and prompt appropriate action before there is an accident. This process should include monitoring minor accidents and near misses in the accident book, as this could give early warning of the potential for a more serious incident.

Access and egress

Suitable provision for safe and controlled access and **egress** is required for all construction sites. It is essential to be able to monitor who is on site, whether they are working on the site or only visiting. This ensures that:

- all people can be accounted for in an emergency
- information or instructions, resulting from ever-changing conditions or dangers, can be safely and speedily distributed
- the security of the site is closely controlled
- the safety of all on-site personnel, or members of the public who may accidentally stray onto the site, is closely controlled.

On most sites, all personnel and visitors should report in and sign an attendance record book. Construction site safety boards are usually located at the entrance points, providing instructions on the basic minimal safety requirements.

All sites must also provide suitable evacuation points that allow all persons to leave the site quickly and safely and go to a designated assembly point, should any emergency situations occur.

HSE inspections

HSE (Health and Safety Executive) inspectors routinely inspect places of work. Although it is unusual to call unannounced, they have the right to enter and inspect any workplace without giving notice.

If they are on a routine visit, rather than responding to a complaint or particular incident, inspectors inspect the workplace, work activities, and methods and procedures used for the management of health and safety, and check compliance with health and safety law relevant to the specific workplace. The inspector is empowered to talk to employees and their representatives, and to take photographs and samples.

Where breaches in requirements are observed, the inspector can serve the following, depending on the severity of the breach.

- **Informal warning** – Where the breach is minor, the inspector can explain on site what is required to the duty holder (usually the employer), following up with written advice explaining best practice and the legal requirements.
- **Improvement notice** – Where the breach is more serious, the notice will state what has to be done, why and when the remedial action has to be completed by. The inspector can take further legal action if the notice is not complied with within the time period specified. The duty holder has the right to appeal to an industrial tribunal.
- **Prohibition notice** – Where there is a risk of serious personal injury, the inspector can stop the activity immediately or after a specific period. The activity cannot be resumed until remedial action has taken place. The duty holder has the right of appeal to an industrial tribunal.
- **Prosecution** – In certain circumstances, the inspector may consider prosecution necessary to punish offenders and deter other potential offenders where circumstances result in serious danger to persons or property.

KEY TERM

Egress: Exiting or leaving an area.

INDUSTRY TIP

Many large construction sites will have security personnel who monitor all who enter or leave the site. Also, when working in an occupied commercial or industrial location, they may control access by means of security staff or access keys/codes and identity badges.

In addition, particular pieces of legislation may carry specific penalties, such as unlimited fines and custodial sentences. These include, as an example, breaching Regulation 9 (2) of the Work at Height Regulations 2005 by not providing sufficient guard rails or netting. Those breaching these measures are generally taken to court by an enforcing authority. In cases of health and safety legislation violation, this is done by the HSE. When cases go to court, specialist lawyers are called on to work through the complexities of the relevant area of law. Often the evidence of expert witnesses is sought to obtain professional opinions on the subject. The outcome will be an acquittal or a sentence with remedial/corrective action.

In general, employers are responsible for the actions of their employees and, where these result in breaches in legislation or accidents, it is the employer that is punished. However, where a breach is entirely due to an employee, the employer has the right to impose its own disciplinary processes, which, at worst, may result in a finding of gross misconduct and dismissal.

KEY TERM



Efficient is a process working with maximum productivity and minimum wasted effort.

Managing an efficient site

In order for a site to work **efficiently**, key planning is required to ensure all necessary plant, equipment and labour is on site as it is required. If too many people are on site, it is costly and if materials or plant are delivered too soon, there is a likelihood that they will become damaged and require replacing. In addition, materials will need to be paid for long in advance of when they are needed and before any interim payments are made to cover the material costs.

Building information modelling (BIM)

Building information modelling (BIM) is the production of a digital three-dimensional (3D) model of a building project. As well as providing detailed plans, layouts and views of a building in 3D, it also shows how different parts of the building interact, including installation sequencing. This in turn can be used to produce work programmes.

BIM can also provide the following benefits to building design and construction:

- a visual image of what the inside and outside of a building will look like for the client to agree. This could be in the form of a virtual tour.
- seeing the positions of controls or accessories or how services such as lighting can integrate.
- the possibility for several designers/stakeholders to collaborate together on a project in real time as the project changes and develops.
- it ensures smooth running of a contract by providing detailed specifications and schedules during the construction phase known as the Digital Plan of Work (DPoW). This is used to organise resources such as materials, plant and labour.

Once a critical path analysis has been carried out, the project manager may decide there is too much risk in a particular critical point and ask the planner to re-plan activities to remove it from the critical path. This involves building contingency time around that point. This will result in a slightly longer programme, but adds an element of realism so that if delays occur around the identified point, they do not affect the critical path.

The basic critical path technique is to:

- list all the activities necessary to complete the project
- add the time that each activity will take
- determine the dependency between the activities, e.g. activity C cannot start until activity B is completed.

The analysis will identify those activities or tasks that are essential – that generally take the longest time to complete and that form the critical path around which the other activities are to be organised.

Critical path example

In its simplest form, the critical path illustrated in Figure 4.9a shows how the sequence of tasks or activities affect each other.

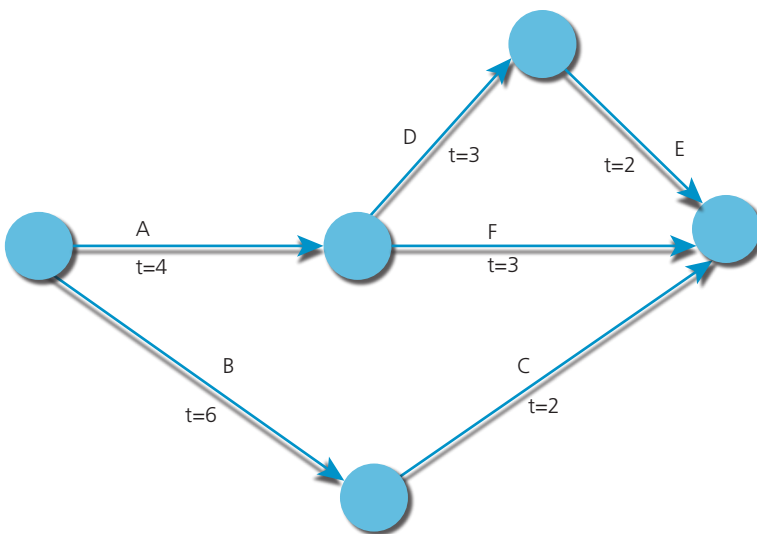

The job has 6 activities
 Activity A takes 4 units of time and is not dependent on any other activity
 Activity B takes 6 units of time and is not dependent on any other activity
 Activity C takes 2 units of time and is dependent on completion of B
 Activity D takes 3 units of time and is dependent on completion of A
 Activity E takes 2 units of time and is dependent on completion of D
 Activity F takes 3 units of time and is dependent on completion of A

The critical path of activity A through D and E and gives a minimum time of 9 units
 Activity F is sub critical and has a float of 2 units
 Path B through C is sub critical with a float of 1 unit

▲ Figure 4.9a Critical path method

- Looking at Figure 4.9, it can be seen that the critical path is the longest route, which is A-D-E, as that takes nine days. Tasks B-C take eight days and A-F take seven days.
- If task F, during the planning stage, was extended to six days, perhaps due to a specific curing or drying period, the whole job would be extended by one day and the path A-F would become the critical path.
- This diagram shows the task details in the connecting lines. Other critical path networks may show the task detail in the circles.

If a contractor or subcontractor fails to work to the specified schedule, they may face financial penalties, which would be set out as a penalty clause in the contract. Although programmes of work do allow for some potential delays, for example due to weather, one of the main benefits of using programmes of work is that the programme can be adjusted in order to minimise delays.

Example method for creating a simple critical path network and bar chart step by step

Below, is an example of how to create a critical path network and bar chart using a simple process of making and baking bread.

- Using a table, set out the tasks that are required and decide if any tasks are reliant on another being finished. For example, it is difficult to mix the ingredients before they are weighed; if you did, the overall process is badly in danger of failing. Also at this stage, consider the time it takes for each task.

▼ Table 4.3 Identify the tasks required

Task	Precede by	Time allowance (minutes)
A – weigh ingredients	-	1
B – mix ingredients	A	3
C – 1st prove mixture (rise)	B	60
D – prepare baking tins	-	1
E – pre-heat oven	-	10
F – knock back dough and place in tins	C&D	2
G – 2nd prove (rise)	F	15
H – cook	E&G	40

- Create path tools. There are several ways these could be represented and Figure 4.9b is one example of showing the information.

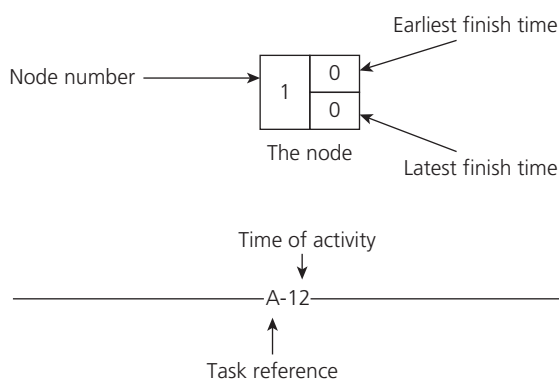

▲ Figure 4.9b Creating and representing path tools

- Create the critical path, taking care that tasks dependent on the completion of another follow each other. Also show tasks that can be carried out at any time, as time can be saved in the process by showing these. If tasks that can be carried out at any time are not shown, there is a danger of spending time on these early in the process and then standing around later

while waiting for something to happen. Tasks not dependent on others could be carried out in that waiting time.

Once the path has been created, this could then be transferred onto a bar chart, so the process is easy to follow and time can be maximised by filling in the gaps of time by the non-dependent tasks.

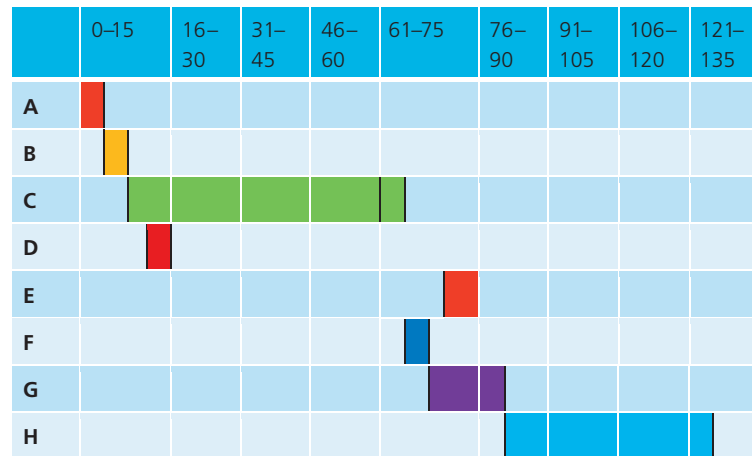
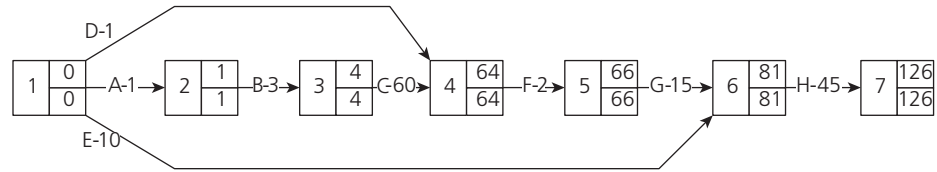

▲ Figure 4.9c Bar chart showing the critical path

Some things considered while creating the bar chart included:

- As H (cook) was dependent on E (pre-heat the oven) but E wasn't dependent on anything, E was carried out during waiting time for the dough to 2nd prove but not too early so that energy used to keep the oven hot was minimised.
- D (prepare baking tins) wasn't dependent on anything but F (knock back dough and place in tins) was dependent on D, so D was carried out in the time waiting for the dough to 1st prove.

INDUSTRY TIP

Changing conditions at the workplace can lead to delays and alterations in the work programme, but good communication between the contractor and other trades can minimise these delays.

Procedures for rescheduling work

Once the work has been scheduled using methods such as critical path networks, we need to consider what affects changes in the work schedule.

One of the most appropriate methods of overcoming changing conditions in the workplace is to hold a site meeting so the impact of the delays may be discussed by all parties concerned. If the rescheduling of work leads to changes to the original contract, a variation order would be issued.

Variation order

The purpose of a variation order (VO) is to change the conditions or clauses of an original contract due to the changing workplace or schedule. Rescheduling work may lead to a financial burden for subcontractors due to the need for additional

material or changing labour requirements. The VO effectively makes allowance for this change in contract. In many cases, the changing work, materials or labour costs would be documented by the subcontractor by issuing the contractor or client with daywork sheets.

Daywork sheets document the additional labour, materials and machinery costs involved from a VO. Daywork sheets are generally used when the VO costs are difficult to estimate.

During work operations, various documents will be used within an organisation. These include:

- purchase orders
- delivery notes
- time sheets.

Purchase orders

Purchase orders provide a method of documenting what materials or plant are purchased. By giving each order a unique number, specific materials can be accounted for to a particular project. Although many wholesalers or suppliers do not require the issue of purchase orders, it is always good practice to use them to allow the delivered items to be checked for accuracy.

Delivery notes

Delivery notes are the documents that are attached to or delivered with any delivery. It is essential that delivery notes are checked against the delivered materials, wherever possible at the time of delivery. This identifies if the wrong materials have been delivered and if items are missing. The delivery note normally requires a signature to confirm the number of items delivered.

If a problem with the delivery is discovered later, responsibility for the problem can be difficult and costly to prove. Missing components will also affect performance on site. The delay in supply of even simple products, such as bolt fixings to secure the structure, can affect the timing on a project badly.

Delivery notes should be checked off and processed through the supervisor. They may then be sent to the administrators for processing or direct to the contractor's quantity surveyor for costing against the project.

Time sheets

Time sheets are a simple but very effective tool in assigning work costs to particular jobs or budgets. They indicate where labour costs have been expended, including where additional works have been carried out and need charging to the client, which is of vital importance to profit levels.

Time sheets that break work down into specific tasks can also be used by managers and estimators to indicate areas where the estimate was totally inaccurate. This information can then be used when pricing future works.

Once submitted, a time sheet is a legal document stating the hours worked on a task or project.

SITE RESTORATION

Repair and restoration

When work is performed in a building, whether alterations, removal of equipment, or new installations, there will always be an element of restoration required. The most commonly damaged parts, either when adding or removing items, are the walls of the building. The three main areas likely to need attention are:

- plaster
- wallpaper
- wall tiles.

A variety of repair techniques can be applied but, in this chapter, just one technique for each form of damage is explained.

Repair to plaster

The amount of damage to the wall will determine the approach to repairing the plaster. In the case of a small crack or hole then a proprietary pre-mixed general-purpose filler may be used. The hole or crack would first be brushed clean of all dust and residue and then the filler would be applied directly, using a wet spatula, to ensure the filler penetrated the hole or crack.

INDUSTRY TIPS

Most general-purpose fillers will shrink as they set, which is why they can only be used on small holes or cracks.

Types of plaster are available that will fill chases, etc. to a depth of 50 mm with one application.



▲ Figure 4.10 Holes or cracks in walls

Once the hole or crack has been filled, the filler must be left to set. Setting and drying time will vary, depending on the make of the filler. The manufacturer's instructions will give guidance. Once set, the filler can be sanded level, but a subsequent layer of filler may be needed to ensure a perfectly smooth finish that can be painted or papered over.

Where the damage is more substantial, then it may be necessary to repair the plaster properly rather than just patch it with filler. Such damage may, of course, be a result of cutting a chase to install cables within a prescribed zone of a wall.

Repairing a wall can result in a lot of dust and debris and both brick dust and plaster dust can damage furniture and floorings. To protect against such damage,

covers must be in place both on the floor and on furniture, before work starts.

To repair a hole or chase, first remove all loose or crumbling plaster. This can be done using a stiff brush and a scraper. Once all loose material has been removed, the hole must have all the dust removed. This can be achieved using either a soft brush or a vacuum cleaner.

With the hole cleaned and free from all debris, spray the area with a fine spray of water and allow to dry. Next, a bonding agent must be applied to the wall. The purpose of the bonding agent is to help the plaster stick into place. Most bonding agents are in liquid form that is either painted on or, more commonly, sprayed on. The bonding agent must be left to dry. This typically takes about 45 minutes. On more porous walls, a second coat may be required but this is uncommon.

When the bonding agent is dry, the hole can now be partially filled with plaster applied with a 100 mm wide **broadknife**. When filling the hole, work out from the centre of the hole towards the edges. The hole must not be totally filled, as a layer of finish plaster will also be required. Leave about 1–2 mm of the depth of the hole unfilled and then, before the plaster sets, scratch the surface with the edge of the broadknife to create a criss-cross pattern.



▲ Figure 4.13 Criss-crossed plaster

The plaster should now be left to set. Some plasters require more than 24 hours, but more modern ones only take a few hours.

Once the first layer of plaster is set, then a finishing coat called a skim coat is applied. Use a 150 mm wide broadknife and start to fill the remainder of the



▲ Figure 4.11 Bonding agent



▲ Figure 4.12 A broadknife

KEY TERM

Broadknife: A tool rather like a wallpaper scraper but much more pliable.

INDUSTRY TIP

A standard plastering trowel is suitable for most repair work. Anything wider than a standard trowel width is best left to a skilled plasterer.

hole, again working from the centre outwards. Fill the hole as evenly as possible, overfilling slightly.

To level the surface, use a piece of straight-edged timber held at an angle or, if possible, use a metal rule. Move the straight-edge up the wall with a side-to-side action, holding it firmly against the existing sound plaster as a guide. Care should be taken to make sure that the straight-edge does not mark or damage the existing plaster.

When removing the straight-edge from the surface, together with the plaster you have scraped off, take care not to drop any on the floor or mark the newly finished plaster. You should now be able to see any hollows, which can be filled with more plaster before repeating the action with the straight-edge.

Keep a bucket of cold water handy at all times, so that you can keep tools clean – especially the broadknife and metal rule – as this will aid with applying and levelling the plaster. On smaller holes, rather than using a straight-edge, use a medium abrasive sand paper to smooth the plaster once it has set.

Plasterboard

Where the wall is not load-bearing, removal of wall accessories will often leave holes in the plasterboard that need to be filled. Unlike on a load-bearing wall,

any attempt to fill a hole in a plasterboard wall will result in the plaster simply falling down into the wall cavity. An alternative is to fit a blanking plate where the accessory was fitted, but these can often look out of place on the wall and may not be exactly what the client wants. If the wiring and pattress or back-box have also been removed, then there is a simple way to repair the hole.

The size of hole that most pattresses would leave, once removed, means it is not practical to try to plaster the hole. An easier method is to secure two pieces of batten just inside the hole, by screwing them in position. Next, cut a piece of plasterboard that is the same thickness as that used for the wall to fit the size of the hole.



▲ Figure 4.14 Repairing a hole in plasterboard

INDUSTRY TIP

When screwing the batten in place, be sure to use rust-protected, counter-sunk screws so that they form a recess which can then be filled with filler to conceal them.

Then insert the piece of plasterboard in the hole and screw it in position. Seal the gaps with filler to conceal the join. Once the filler has set, it can be sanded to a smooth finish. When painted or papered, the hole will no longer be visible. This method can also be used to repair holes in ceilings.

Repair to wallpaper

Hanging wallpaper is an art form and one that only practice can make perfect. Fortunately, modern wallpapers are easier to hang than traditional papers. Wallpaper can become damaged when installing cables in walls or moving items and can only really be repaired if some of the original wallpaper is available.

To repair the section of wallpaper, the original **drop** must first be removed, using a wallpaper scraper. Take care not to damage further drops where possible. Stripping wallpaper is a messy job, so cover carpets with dustsheets and also cover furniture that may be at risk of damage.

Use warm water to soften old, absorbent wall coverings, then use a wide wallpaper scraper to strip the paper off the wall. A steam-generating wallpaper stripper makes the job easier but it can cause damage to older walls. When removing painted wallpapers or washable wall coverings, scratch the surface with a wallpaper scorer to enable the moisture to penetrate. You can peel vinyl wall coverings off the wall, leaving the backing paper behind. If it is sound, just paper over the backing, or strip it like ordinary wallpaper.

Using the replacement wallpaper, measure the size of the drop required, taking care to match any pattern where possible. Cut the paper a little bit longer than required, to allow for trimming when the paper has been hung. Mix a small amount of wallpaper paste, according to the manufacturers' instructions, and then, using a broad brush, apply the paste sparingly to the back of the cut drop of paper. Make sure that all the back of the paper is covered.



▲ Figure 4.15 Stripping wallpaper

Position the pasted wallpaper onto the wall and then, using a dry, soft brush, smooth the paper into position, making sure to brush out any air bubbles and remembering always to work outwards from the centre. When the drop is in

KEY TERM

Drop: The amount of paper that is required to cover a strip from the ceiling to the floor.

INDUSTRY TIP

When pasting the paper, the paper can be folded back on itself to make it easier to carry.



▲ Figure 4.16 Pasting wallpaper

INDUSTRY TIP

Special tile saws are available. For straight lines, a tile-cutter, similar to a glass-cutter, can be used. For irregular or rectangular cut-outs, a masonry drill can be used at the corner of the hole and then a special blade can be used to cut the edges of the hole.

HEALTH AND SAFETY

Remember to wear eye protection, dust mask and gloves when drilling the tile.

place, trim the surplus, from the top and bottom of the piece, using a very sharp trimming knife and if necessary, a steel straight-edge.

VALUES AND BEHAVIOURS

Remember to protect the customer's property where possible. Do not get any of the paste on the front of the paper as this will mark the paper.

The alternative to doing this yourself is, of course, to hire in a professional or agree an action with the client before the work is commenced. Some clients will use this as a reason for some redecorating.

Replacing wall tiles

Wall tiles will be found in most installations near sinks, baths or showers. Once tiles become damaged, they cannot be repaired and need to be removed and replaced. This is a problem, as the damaged tile may be surrounded by other tiles that could also be damaged during removal of the original tile. Great care must be taken throughout the tile removal process.



▲ Figure 4.17 Damaged wall tiles

Before you can remove the damaged tile, you will need to weaken it by drilling 5 mm diameter holes in the surface. Most tiles have a smooth, glazed finish, so it can be helpful to use masking tape to create a large diagonal cross on the tile.

Then, using a masonry drill bit, drill a series of holes at regular intervals along the two lengths of tape with holes not more than 10 mm apart.

It is important only to drill through the tile and not into the wall, so use a drill depth gauge. A replacement tile can be used to establish the depth of hole required.

Once you have weakened the tile by drilling the holes, use a grout rake to remove the grout from around the tile. Take care to ensure that the surrounding tiles are not damaged when using the grouting rake. Sometimes tile spacers will have been used to ensure equal spacing between tiles. These plastic spacers can often cause a grout rake to slip, so take particular care at each corner.

With all the grout removed from around the damaged tile, the next stage is to start removing the tile. Using a sharp cold chisel and hammer, chip away at the tile, starting from the middle, and work out towards the edges along the masking tape. Care must be taken to avoid damaging the wall by hitting too hard, or through the chisel slipping.

Once the tile has been broken along the masking tape, remove the tape and clear away any of the tile that has come loose. The remaining pieces of broken tile also need to be removed. This is best performed using an old wood chisel, bevel-side down, underneath the remaining sections of tile.

With the tile now removed, it is important to prepare the wall for the replacement tile. Start by using the wood chisel to continue to remove the old adhesive. It is a good idea to use the new tile as a depth gauge to establish how much old adhesive needs to be removed, and from where. In order for the new tile to be easily and safely removed from the hole, it is a good idea to attach a piece of masking tape, as a tab, to the front of the tile to provide something to grip.

Once the wall has been cleaned to the correct depth, use an adhesive comb to apply tile adhesive to the back of the new tile. Having already used the tile to see if the wall was level will have given an indication of how much tile adhesive is needed. Use the tab to grip the tile and position the new tile in the prepared hole, making sure it is flush with the surrounding tiles.

The tile can be evenly spaced by using tile spacers, but this time with them positioned just in between the gaps at the bottom and sides rather than at the corners of each tile. With spacers in place, the tile adhesive must be left to harden. The time to set will vary, depending on the type of adhesive used, but typically, ready-mixed adhesive requires about twenty-four hours to set. Fast-setting adhesives are available, but always read the instructions.

Once the adhesive has set, the spacers can be removed and the space around the tile can be filled with grout to reseal the tiles. The grout can be applied with a grout-finishing tool and then any excess can be polished off with a dry cloth, once the grout has dried.

INDUSTRY TIP

If the drill to be used does not have a depth gauge, then a piece of masking tape can be wound round the drill bit to mark the maximum drill depth.



▲ Figure 4.18 Tile spacers

HEALTH AND SAFETY

Remember to wear eye protection, dust mask and gloves while breaking and removing the tile.



▲ Figure 4.19 Fast-setting tile adhesive

Tidying up

Once any repair work has been performed, it is important to clean up properly. This includes removing all rubbish and waste materials. Dust sheets and covers that have been used must be carefully folded in on themselves so as not to generate any more dust and to capture any residue inside the sheets.

With the dustsheets and protective covers removed from the work area, it is time to use the most important tools in terms of customer relations, the dustpan and brush and vacuum cleaner. Ensuring the work area is clean and tidy after you have finished will often go a long way towards bringing repeat business from many clients. It also provides a chance to confirm that all tools have been collected and packed away, rather than being lost or misplaced.

Handover information

Handover information needs to be delivered in order to achieve **practical completion**. As buildings have become more sophisticated, operation and maintenance documentation, for example, has become even more important. Handover information should include:

- a design philosophy and statement to say how the building has been designed and how it is to be operated – often now part of the building logbook
- Building Regulations tests and approvals, including the sign-off documents from the building control officer or approved inspector
- building leakage test certificates from construction
- the energy performance certification and registration information
- electrical test information
- lighting compliance certification (e.g. compliance with CIBSE LG7)
- emergency lighting test certification
- fire-alarm certification
- emergency voice communication or disabled refuge system certificate
- construction plans at a scale of 1:50 or 1:100 as appropriate
- **building envelope** details
- structural plans with floor loadings, any specialist support information for plant, etc.
- mechanical and electrical equipment layouts at a scale of 1:50 or 1:100 as appropriate
- plant and specialist area layouts at a scale of 1:50, or even 1:20, depending on complexity of the systems
- additional information relating to the cleaning, maintenance and deconstruction of any of the systems or components and any disposal requirements at the time of writing the handover information.

It is very important that the documents are up to date and specific and relevant to the building or project being handed over.

KEY TERMS

Practical completion:

Where a certificate is issued to verify all works have been undertaken as contracted.

Building envelope: The fabric of the building.

INDUSTRY TIP

Handover should ideally be carried out face-to-face with the client as this is a better way to gauge that they understand important instructions such as, for example, the need to test RCDs every six months.

Test your knowledge

- 1 Who is responsible for handing over the safety certification for installed electrical equipment, to the client, following installation work?
 - a Manufacturer.
 - b Architect.
 - c Contractor.
 - d Local authority.
- 2 What type of drawing shows a sequence of control?
 - a Plans.
 - b Schematics.
 - c Layout.
 - d Wiring.
- 3 Which of the following would be a residual hazard identified in an operation manual?
 - a An unavoidable hazard that exists on completion of work.
 - b A major hazard that exists during the construction phase.
 - c A minor hazard linked to installing electrical equipment.
 - d An avoidable hazard that is identified during installation.
- 4 What is used to help determine the number of socket outlets on a tender drawing?
 - a Circuit schedule.
 - b Drawing legend.
 - c Provisional sum.
 - d Take-off sheet.
- 5 What is a provisional sum?
 - a The entire tender price submitted to the client.
 - b The estimated cost to install a specific item of equipment.
 - c A quotation for all work subject to a variation order.
 - d A percentage of the overall quote to cover overheads.
- 6 What is issued by the client's representative when the quantity of sockets required increases during the work?
 - a Daywork sheet.
 - b Variation order.
 - c Schedule of rates.
 - d Bill of quantities.
- 7 What is an essential welfare facility?
 - a Canteens.
 - b Storage units.
 - c Toilets.
 - d Safety barriers.

- 8 What term is used to describe a delivery that does not include everything according to the original order?
- a Short shipment.
 - b Tall order.
 - c Interim order.
 - d Lost shipment.
- 9 What document is used to record dangerous defects in the existing part of an installation where new circuits have been added.
- a Schedule of test results.
 - b Electrical Installation Condition Report.
 - c Risk assessment document.
 - d Installation method statement.
- 10 What is egress?
- a A form of corrosion.
 - b Means of exiting a site.
 - c Working slowly.
 - d Missed completion times.
- 11 Explain the purpose of a prohibition notice issued by an HSE inspector.
- 12 Describe the purpose of a critical path.
- 13 List three methods of protecting a floor while working in a domestic property.
- 14 Describe the reasons for carrying out a pre-work survey.
- 15 Describe one factor when considering the location of a storage container.
- 16 What type of product description is 'polished chrome', when referring to a socket outlet?
- a Loading.
 - b Feature.
 - c Dimension.
 - d Finish.
- 17 What is the **main** advantage of using a wholesaler's catalogue over a manufacturer's catalogue?
- a Product dimensions are clearer.
 - b Product prices are always cheaper.
 - c Products from different manufacturers can be compared.
 - d Products from the same manufacturer can be compared.
- 18 What would be the actual length of a wall if it was shown on a 1:50 plan as 25 cm long?
- a 2.5 m
 - b 10.0 m
 - c 12.5 m
 - d 25.0 m
- 19 Which one of the following items of information must be included in an operation and maintenance manual?
- a Original tender drawings and specification.
 - b Manufacturer's installation instructions.
 - c Electrical Installation Certificates.
 - d Installation final invoice.

- 20** What quality standard shows that an organisation meets the needs of their clients while meeting regulations?
- a** BS 7671
 - b** ISO 9000
 - c** HSE GS38
 - d** IET GN1
- 21** What is the system of ordering materials when they are needed formally known as?
- a** Just in time.
 - b** Necessity ordering.
 - c** Prospective planning.
 - d** As and when.
- 22** What is the **most** appropriate method of protecting a carpet in a client's house from the outdoor mud on an operative's boots when they need to go inside to isolate a circuit?
- a** Place boards on top of the carpet.
 - b** Lay down plastic sheeting throughout.
 - c** Wear over-boot protectors.
 - d** Remove footwear altogether.
- 23** At what point in a contract should an Electrical Installation Certificate be issued?
- a** During handover once all works are complete and commissioned.
 - b** On payment of final invoice but before equipment is commissioned.
 - c** After the warranty period for the installation has expired.
 - d** Before the final equipment is installed as these may affect results.
- 24** Describe the difference between a quotation and estimate.
- 25** Explain **one** main advantage that using building information modelling (BIM) provides for a client.
- 26** Give **three** examples of good customer service principles.
- 27** Describe what should be included in overhead costs.

Practical task

Visit the City & Guilds website, at: www.cityandguilds.com

Access the Level 4 assessment material for '2396' and download a set of project drawings.

Ask your tutor to print them off in A3 format. They are supposed to be A1. In A3, work out a new scale for the drawings because the original A1 scales printed on them will no longer be correct. Tip: door widths are standard in size.

ELECTRICAL INSTALLATION DESIGN

INTRODUCTION

Every installation requires some degree of design. When an electrician simply selects a 2.5 mm² cable because that is what they always use, or when somebody spends dedicated time calculating each circuit, it is still design.

The individual who decides what is to be installed is effectively the designer for that installation and thus carries all associated responsibilities. Regulation 132 of **BS 7671: 2018 (2022)** The IET Wiring Regulations, 18th Edition states:

‘The electrical installation shall be designed by one or more skilled persons to provide for:

- the protection of persons, livestock and property in accordance with Section 131
- the proper functioning of the electrical installation for the intended use.

The information required as a basis for design is stated in Regulations 132.2 to 5. The requirements with which the design shall comply are stated in Regulations 132.6 to 16.’

BS 7671 makes it clear that before design begins, the designer must have information relating to:

- characteristics of supply
- nature of demand
- safety services
- environmental conditions.

Then, the design is based upon, where applicable, the **fundamental principles** in Regulations 132.6 to 132.16, which contain details relating to the design of:

- cross-sectional area (csa) of conductors
- type of wiring and method of installation
- protective equipment
- emergency control
- disconnecting devices
- prevention of mutual detrimental influences (deterioration of electrical or other services should they affect one another; an example is hot-water pipes damaging cables)
- accessibility of electrical equipment
- documentation for the electrical installation
- protective devices and switches
- isolation and switching
- additions or alteration to an installation (effects on existing systems).

This chapter looks at the process of design and how it is applied to common types of electrical installations. It pulls together all the knowledge covered in Book 1 and this book so far. Note that inspection and testing will be covered separately in Chapter 6 of this book, and fault diagnosis in Chapter 7.

The designer of an installation requires knowledge of:

- health and safety: the future installation must allow for safe and suitable operation and maintenance (Book 1, Chapter 1)
- scientific principles: how electricity affects cables, equipment, etc. (Book 1, Chapter 2; Book 2, Chapter 2)
- installation practices and technology: the characteristics of wiring and wiring systems (Book 1, Chapters 3 and 4)
- environmental technologies: how they integrate with electrical systems (Book 2, Chapter 1)

- working on site: the surveys needed to gain the correct and effective information (Book 2, Chapter 4)
- BS 7671: the very foundation of safe and efficient design (Book 2, Chapter 3).

KEY TERM

Fundamental principles:

The basis of Chapter 13 of **BS 7671**: they are not just the foundations of BS 7671 but are the design principles a designer should work to. Section 132 and the regulations within are considered as the designer's checklist.

HOW THIS CHAPTER IS ORGANISED

Before reading this chapter, you will need to remind yourself of the detail relating to wiring systems, installation methods, fixings and how to install them. These topics were all covered in Book 1, Chapter 4.

Table 5.1 shows the topics that will be covered in this chapter.

▼ Table 5.1 Chapter 5 assessment criteria coverage

Topic	5357-004/104 Understand Design and Installation Practices and Procedures	2365-305 Electrical Systems Design	8202-303 Electrical Design and Installation Practices and Procedures	5393 104/004 Understand Design and Installation Practices and Procedures
Supply characteristics: <ul style="list-style-type: none"> ● Existing supplies ● New supplies ● Responsibilities 	4.1; 4.2	4.1		4.1; 4.2; 4.3
Circuits: <ul style="list-style-type: none"> ● Arrangement ● Types 	7.1; 7.2	7.1; 7.2	4.1; 4.2	2.5 7.1; 7.2
Type of wiring system and method of installation: <ul style="list-style-type: none"> ● External influences 	2.1; 2.2; 2.3; 2.4; 2.5	2.1; 2.2; 2.3; 2.4; 2.5		
Protective equipment: <ul style="list-style-type: none"> ● Distribution ● Circuit protection ● Isolation and control 	4.3 6.1; 6.2; 6.3; 6.4	4.3 6.1; 6.2; 6.3; 6.4	3.1; 3.2; 3.3	4.5
Circuit design procedure: <ul style="list-style-type: none"> ● Single-circuit live conductors ● Full circuit design including protective conductors ● Considering overload 	5.3; 5.4; 5.5; 5.6; 5.7 8.2; 8.4; 8.5; 8.6; 8.7; 8.8; 8.9; 8.10; 8.11	5.3; 5.4; 5.5; 5.6; 5.7 8.2; 8.4; 8.5; 8.6; 8.7; 8.8; 8.9; 8.10; 8.11	2.1; 2.2; 2.3 5.2; 5.3; 5.4; 5.5; 5.6; 5.7; 5.8	11.1; 11.2; 11.3; 11.4; 11.5; 11.6; 11.7; 11.8; 11.9; 11.10; 11.11
Maximum demand and diversity	8.1; 8.3	8.1; 8.3	5.1	7.3
Accessibility aids in domestic installations				8.1; 8.2; 8.3; 8.4; 8.5

Make sure you have **first** studied the content in Chapter 3, which covers the knowledge underpinning the design processes described in this chapter. Chapter 3 and Chapter 5 are closely linked and there is significant crossover.

- **Chapter 3** sets **BS 7671** in context, explaining areas such as earthing arrangements, protective conductors and how automatic disconnection of supply works.
- **Chapter 5** focuses on the design procedure, including the many calculations required.

T Level mapping grids are available on the Hodder Education website. These map the book to the occupational specialisms: 8710-353 (Electrical Engineering) and 8710-352 (Electrical and Electronic Equipment).

SUPPLY CHARACTERISTICS

Part of the design process is having knowledge of the supply details or, if there is no supply available, knowing how to obtain one.

Existing supplies

Before any design is carried out within an electrical installation, details relating to the supply must be looked at and assessed as they can change the way the design is undertaken and what type of protection is used. If frequency and voltage are **nominal**, the supply details can be looked at in four ways:

- live conductors – how many?
- current – what is the maximum rating?
- prospective fault current – how large is it?
- earthing arrangement – what earthing system is used and what is the value of external impedance?

KEY TERM

Nominal: Nominal voltage to earth (U_0) in the UK is 230 V, so if you measure the voltage between line and earth, you should read 230 V. In reality, the voltage is likely to be higher than this or in some cases, lower. It all depends on where the installation is in relation to the substation transformer. The further away, the more voltage is lost, so the lower the real voltage. Voltage can also vary with demand. The more demand that is placed on a substation transformer, the lower the voltage will be.

As voltage can vary, a standard measurement is required that we can use in calculations. We use these nominal (normal) values:

- Nominal voltage to earth (U_0) = 230 V
- Nominal voltage (U) line to line or line to neutral = 400/230 V.

For information relating to the maximum and minimum actual supply voltages, see Appendix 2 of BS 7671: 2018 (2022) The IET Wiring Regulations, 18th Edition.

INDUSTRY TIP

Always remember that a neutral carries a current, so it is classed as a live conductor. Where supply has two live conductors, it is described as two-wire.

Live conductors

Supplies to small domestic-type installations are normally single-phase 230 V, so there are two live conductors (line and neutral).

Larger installations, which normally need more than 100 A, will typically be given as three-phase supplies, which allows the larger loading to be spread over the three phases at the substation transformer, keeping it more efficient.

Table 5.2 summarises the live conductor arrangements in the UK.

▼ Table 5.2 UK live conductor arrangements

Type	Arrangement	Where?
Single-phase 230 V L-N	Two-wire	Dwellings, small shops or small commercial buildings
Three-phase 400 V L-L	Three-wire (no neutral)	Not very common as supplies to installations because all circuits must be three-phase balanced loads
Three-phase and neutral 230 V L-N : 400 V L-L	Four-wire	Larger retail outlets, larger commercial or industrial buildings

Chapter 31 of **BS 7671** includes diagrams of the various conductor arrangements.

Current

Another factor that affects the supply is the current rating, which is known as maximum demand. Most average-sized houses in the UK will have a maximum demand less than 100 A and many houses in a road or estate will be supplied from a single substation transformer. Most commonly, house supplies are rated at 80 A.

Larger installations that have a maximum demand over 100 A are likely to be supplied using three phases in order to spread the load in the supply. Where a building needs a supply over 400 A per phase, it may have its own substation transformer installed on site.

The maximum demand for an electrical installation will be governed by the size of the incoming supply cables and the rating of the distribution network operator's (DNO's) service fuse, so where an installation is to be added to, you must always check that the supply has enough capacity for the extra load.

Where a new building is to be given a supply, the DNO needs to know the proposed maximum demand for the electrical installation, so it can provide an adequate supply. It would be the role of the designer to provide this.

Typical current ratings of DNO service fuses are 63 A, 80 A, 100 A, 125 A, 150 A, 200 A, 300 A, 400 A and 500 A.

The DNO's service fuse is fitted inside the electrical **service head (cut-out)**.

It is always important to know the supply rating, but it is not always easy to see what the DNO fuse rating is. In this situation, you should always contact the DNO, who can tell you all the supply details, such as rating.

Most DNO fuses will be in a fuse carrier that is 'sealed' to the service head, meaning the fuse can only be removed or replaced by a person approved by the DNO. The seal is a small wire which, with a special sealing crimp tool, locks the fuse to the service cut-out, so the seal must be broken if the fuse is to be removed. Connections to meters will also be sealed in this way. You must always contact the DNO if you need to remove a fuse from a service head.

Earthing arrangement

The earthing arrangement is the system describing how the electrical installation and supply is earthed. In the UK, there are three common earthing arrangements. These are described using abbreviations and were covered in detail in Chapter 3, pages 174–8. The type of earthing arrangement given by the DNO depends a lot on where the installation is located and how old the installation supply is.

The most common earthing arrangement now used in the UK is TN-C-S, otherwise known as protective multiple earthing (PME).

If you contact the DNO and ask for details of the supply, they will normally declare values of external loop impedance (Z_e) as:

- TN-C-S: 0.35 Ω
- TN-S: 0.8 Ω .

KEY TERM

Service head (cut-out):

The enclosure that the supply cable is terminated into before it tails to the meter.

New supplies

When a new building or facility is developed, there is no existing supply and so a new supply must be obtained from the DNO.

In order for a new supply to be arranged and installed, the DNO needs to know certain additional details or information before the supply can be installed.

These include:

- address
- site plans and location plans
- type of property and property details (e.g. number of bedrooms, number of outbuildings)
- load requirements (known as maximum demand, including diversity)
- notification if it will be a landlord's connection
- notification of 'disturbing loads', such as motors, lifts, welders, large refrigerators or machinery.

INDUSTRY TIP

Various examples of an application form for an electricity connection can be found on the internet, but be careful to use a known DNO's form, not a third party company who may charge additional fees to provide this service.

Responsibility

Once the supply has been metered, it generally stops being the responsibility of the DNO and now becomes the responsibility of the consumer, the person who owns the electrical system inside the building, or, in simple terms, the person who pays the electricity bill.

In some situations, more likely in newer buildings, there may be a switch between the meter and the consumer unit (CU). This switch may have been fitted by the DNO or by the contractor who carried out the installation work. If you are designing a new installation, it is always a good idea to fit a switch just after the meter so that work can be carried out to all parts of an installation, including inside the CU, with total isolation and without the need for the DNO to come and remove the cut-out fuse.

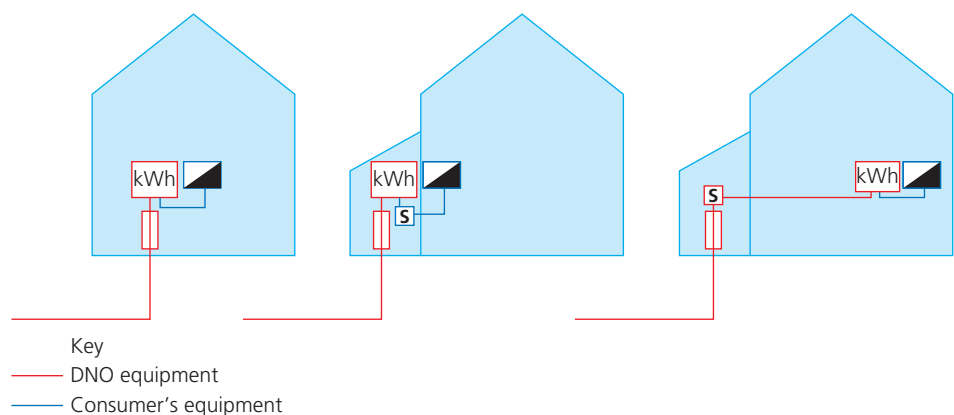

▲ Figure 5.1 Typical layouts indicating responsibility where the meter is in the house next to the CU, where the meter is external and the CU internal, where the cut-out is external and the meter internal

Tails

Tails is the name given to the single-core and sheathed cables that go into and out of the meter. Single-core cable is used to allow flexibility and easy installation.

Tails must be insulated and sheathed as they must have mechanical protection. Having two layers of insulating material gives them much better protection and reduces the risk of electric shock from them.

Tails must be as short as possible. The two layers of insulation must cover the entire cable, especially when inside a metal consumer control unit, right up to the point where they connect to the main switch inside the unit.

If the CU is located away from the meter point, then double-insulated tails should not be used and a much better cable, such as a steel-wire armour cable, should be used. The cross-sectional area (csa) of the tails is normally stipulated by the DNO or sized in accordance with the intended maximum demand.

Regulation 522.8.5 stipulates that meter tails must be supported in such a way that no undue strain should be placed upon the termination with equipment due to the weight of the cable so, except for really short tails, they should ideally be supported by clips or cleats.

CIRCUITS

There are generally three circuit arrangements. These are:

- radial power circuits
- ring-final circuits
- radial lighting circuits

Radial power circuits

Radial circuits are simply circuits that supply a single item of equipment or multiple items, such as socket outlets, using one cable containing a line or lines (for three phase), a neutral and a circuit protective conductor (cpc).

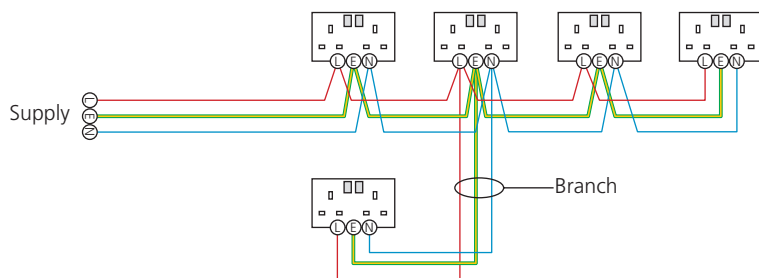

▲ Figure 5.2 Radial circuit showing branch

Radial power circuits generally supply socket outlets but may also supply individual appliances or loads. Power circuits may be wired in two different ways: ring-final and radial.

The major advantages for using radial power circuits is that the cable csa is designed and selected to match the load and protective device so, if designed correctly, the cable will be protected. In addition, should a fault occur in a circuit, such as a loose connection (open circuit), then the equipment will not function, meaning someone is likely to report the fault and have it corrected immediately.

INDUSTRY TIP

Remember, we covered the types of circuit in greater detail in Book 1, Chapter 3.

INDUSTRY TIP

Appendix H of the IET On-Site Guide and Appendix 15 of **BS 7671: 2018 (2022)** give more guidance on the configuration of radial power circuits.

Radial circuits may be branched where additional items are added or to ease the wiring to a socket outlet or equipment that is not on route with others and it may be easier to take a single cable instead of two; one there and one back. Branches are acceptable but should be minimised as too many could make fault detection harder.

Ring-final circuits

Ring-final circuits are the conventional means of wiring socket-outlet circuits within the UK. The reason for their use was to provide a high number of conveniently placed outlets adjacent to the loads. The circuit load is shared by two conductors in parallel. This also assists in improving voltage drop as the conductors being in parallel reduces the overall resistance.

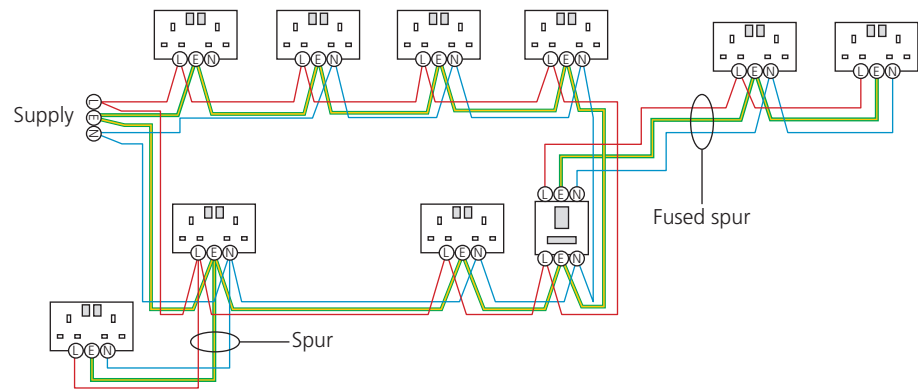

▲ Figure 5.3 Ring-final circuit showing spurs

INDUSTRY TIP

Appendix H of the IET On-Site Guide and Appendix 15 of **BS 7671** give more guidance on the configuration of ring-final circuits.

Ring-final circuits are able to supply an unlimited number of outlets serving a maximum floor area of 100 m². Permanent loads, such as immersion heaters, should not be connected to a ring-final circuit. Ring-final circuits supplying kitchens should be arranged to have the loads equally distributed around the circuit. The plugs and fused connection units are normally fitted with 3 A or 13 A fuses.

Spurs are like branches in a radial circuit and are common where socket outlets are added to existing ring circuits. There are limitations to the amount of spurs, and the amount of outlets per spur, as the cable used for the spur is undersized for the protective device as there is no second set of conductors in parallel to the spur.

With technology reducing the consumption of appliances and equipment, the need for a ring-final circuit is being questioned as this arrangement does have several disadvantages.

- If a ring-final circuit becomes an open circuit, this may not necessarily be detected by the user because power will still be distributed to all socket outlets. Circuit conductors may then become overloaded, leading to the possibility of fire.
- Earth fault loop impedances and circuit resistance values between live conductors may also increase due to this, leading to increased disconnection times.
- Testing the continuity of ring-final circuits is more time consuming than testing the continuity of radial circuits.

Designers today are very likely to specify radial socket-outlet circuits with a reduced nominal rating of protective device due to these reasons. This also reduces the inconvenience of many socket outlets being lost due to a single-circuit failure.

Radial lighting circuits

Lighting circuits are generally rated at 6 A but can in some installations be rated at 10 A or 16 A. With the rise in energy-efficient LED lighting, some lighting circuits need only be rated at 3 A. Consideration must be given to the type of lighting point connection used for higher rated circuits due to requirements within Chapter 55 of **BS 7671**.

Depending on the type of wiring system, lighting circuits may be wired:

- three-plate – for circuits wired in **composite cable**, such as thermosetting insulated and sheathed flat-profile cable, commonly found in domestic dwellings
- **conduit method** – for circuits wired in single-core cables within a suitable containment system.

Three-plate

Because composite cables limit the freedom to take a single conductor between one point and another, lighting circuits wired in composite cables require more joints within the circuit. These additional joints in the cable are called loop-ins and are usually in the form of a third live terminal within a light point, such as a ceiling rose. As the rose contains a third terminal, the system gets the name three-plate.

Although it is traditional to install the three-plate at the light point, this is not necessarily the case in all situations. Many installers will install the three-plate at a switch. This is now very common practice, especially when the wiring in the ceiling is difficult to access, such as in multi-storey flats or flat roofs. The added advantage to this is that it reduces the amount of connections at luminaires where many luminaires or drivers/transformers for luminaires do not have the terminal, or space, for the loop-in connection.

Figure 5.4 shows the loop-in connections at the light and that a two-core with cpc cable is used to connect the switch. Other light points can be installed on the circuit by looping off the ceiling rose. The circuit can be modified to allow two-way or intermediate switching, which we covered in Book 1, Chapter 3.

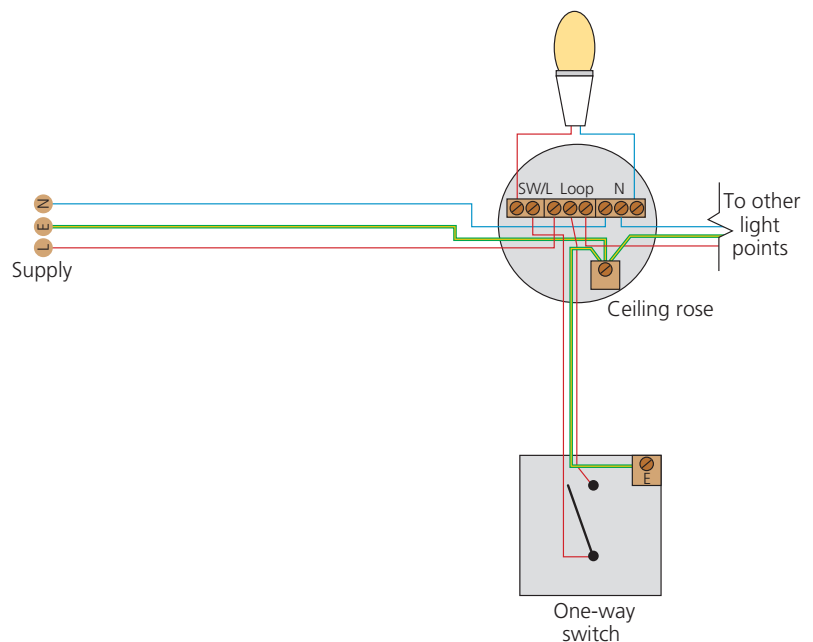

▲ Figure 5.4 A three-plate one-way lighting circuit

KEY TERMS

Composite cable: Multi-cored, where the cores are surrounded by a sheath providing mechanical protection.

Conduit method: This is a common name given to a system where the circuit is wired using single-core non-sheathed cables. They may be installed in trunking as well as conduit.

Conduit method

Because single-core cables can be drawn into conduit or trunking, there is no need to break the cable at the light point as the cable can be drawn straight to the switch. This has the advantage of reducing the amount of connections in a circuit and thus reducing the possibility of faults occurring. Circuits wired this way can also be easily reconfigured for additional lighting points or switches, such as two-way arrangements.

Energy efficiency

In commercial installations, lighting can account for much wasted energy. Lighting circuits, if arranged correctly, could be switched off during times of zero usage and full daylight. This could be achieved by zoning a lighting circuit and arranging automated switching devices to activate lighting by:

- daylight sensors or light-sensitive switches: to control luminaires located near windows by switching them off when the daylight provides suitable levels of light
- movement sensors: to keep luminaires switched off until the area in which they are located is accessed
- time-delay switches: to control luminaires located in less used walkways or stairways by switching them off after a suitable time.

VALUES AND BEHAVIOURS

Refer to Appendix 17 of **BS 7671** for guidance on improving the energy efficiency of installations.

INDUSTRY TIP

The whole nature of electrical sub-distribution and final distribution for commercial installations has changed in the last few years. There is a demand for more residual current device (RCD) protection of final circuits, more metering and often more control to meet energy-saving targets.

Types of circuit

Regulation 132.3 in **BS 7671: 2018 (2022)** The IET Wiring Regulations, 18th Edition states:

‘The number and type of circuits required for lighting, heating, power, control, signalling, communication and information technology, etc shall be determined from knowledge of:

- (i) location of points of power demand
- (ii) loads to be expected on the various circuits
- (iii) daily and yearly variations in demand
- (iv) any special conditions, such as Harmonics
- (v) requirements for control, signalling, communication and information technology, etc
- (vi) anticipated future demand if specified.’

This requirement demonstrates the importance of dividing an electrical installation into different circuit types to meet the different functions of a complete working electrical installation.

By dividing circuits into types based on location and expected loads, system reliability can be enhanced, cables can be kept to sensible sizes and appropriate protective devices can be used.

There are two types of circuit within an installation. These are:

- distribution circuits
- final circuits.

Distribution circuits

Distribution circuits link together distribution boards (DBs). When used effectively, they can reduce the lengths of final circuits by enabling DBs to be positioned centrally to the loads they are supplying.

Within an installation, the first point where the supply is divided is generally called the consumer unit (CU). Any further DBs within the installation are supplied using distribution circuits.

Distribution circuits are sized taking diversity into account. This takes into consideration the fact that not all of the loads supplied by the DB will be fully loaded at all times. As a result, the cable does not need to be sized to carry the full capacity of the DB or the full load of all its final circuits. Diversity will be covered in more detail later in this chapter.

Final circuits

Final circuits are those that supply the current-using equipment (loads). As we have seen, final circuits may be power and lighting, ring or radial. Apart from a few exceptions, such as a cooker circuit, diversity may not be applied to a final circuit, meaning it has to be rated and sized for the intended full-load current.

As long as a circuit has been sized correctly, there are no restrictions on what it can supply but consideration should be given to Section 314 of **BS 7671**, which gives reasons why installations are divided into circuits. The reasons are:

- to minimise danger or inconvenience should a fault occur by keeping other circuits, such as lighting circuits, operating if a fault occurs in one single circuit, tripping its circuit protective device
- to reduce the possibility of nuisance tripping of RCDs
- to allow for safe inspection, testing and maintenance by isolating sections of an installation.

Other circuits or terms used to classify circuits

While working in the electrical industry, you will hear many other terms used to describe or classify circuits or even sections of a circuit. Table 5.3 explains some of these terms.

INDUSTRY TIP

For more information on the application of diversity to a final circuit, see Table A1 in the IET On-Site Guide.

INDUSTRY TIP

The difference between a consumer unit and a distribution board

A consumer unit (CU) is a specific type of distribution board (DB) that is single-phase and rated up to 100 A. **It must have incorporated within it a main switch** and this switch must break both the line and neutral together.

A DB does not require the breaking of the neutral at the main switch (unless TT). In addition, the main switch does not have to be incorporated inside a DB.

Within this chapter, we will typically use the term DB unless the specific use of CU is applicable.

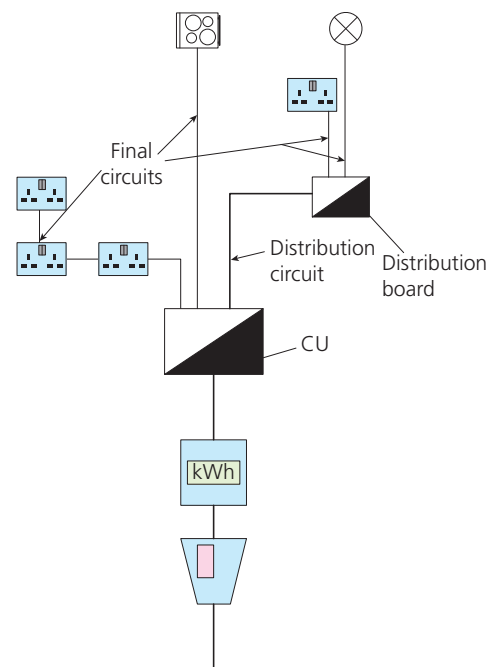

▲ Figure 5.5 Final and distribution circuits in a simple installation

▼ Table 5.3 Circuit classifications

Category	Description
Band I	A circuit operating at any voltage below low voltage (< 50 V AC or < 120 V DC). Such circuits could include telephone systems, data systems, extra-low voltage lighting and signal cables. Band I circuits shall never be in the same enclosure as Band II circuits unless they have the same degree of insulation.
Band II	A circuit operating at low voltage (> 50 V AC), such as general lighting and power circuits.
Safety circuit	A circuit operating fire alarm and emergency systems and which requires additional protective measures, such as separation from other circuits, so it is not affected by any faults on the other circuits. Further protection, by wiring the circuit in fire-proof cabling, may be considered. Other examples of safety circuits include centrally supplied emergency lighting, supplies to firefighters' lifts and supplies to pumps for sprinkler systems.
Essential circuits	These are supplies to equipment such as IT equipment or lighting in the stairwells of high-rise buildings. Essential circuits are dual supplied by the normal mains power and, in the event of power loss, a standby generator or uninterruptible power supply (UPS).
Emergency lighting circuit	An emergency lighting circuit is normally one where emergency lights are supplied from a central source, which could be a large battery set or generator. Sometimes it is also used when referring to part of a general lighting circuit, where sections may supply self-contained emergency lights and these are wired via a key-operated switch. This allows the emergency luminaires to be tested for function by taking away the power to them but leaving the general lighting on.
Auxiliary circuits	Circuits that control a main circuit and are used for remote switching or monitoring of a circuit, such as a motor control circuit with remote start and emergency stop buttons. The auxiliary circuit is supplied from the main circuit but requires protection as it is normally wired using much smaller cable than the main circuit. Methods used to protect these circuits are given in Chapter 55 of BS 7671 .
Boiler control circuit	Where timers, thermostats or controllers are used to activate zone-control valves and boilers.
Security circuits	For example, intruder alarm systems.
Photovoltaic (PV) circuits	These are the circuits that are supplied at DC from photovoltaic (solar) cells and are live all the time the PV cell is exposed to light.
Electric vehicle (EV) charging circuit	A dedicated circuit to supply electric vehicle charging equipment designed to charge electric cars. These are now mandatory in new build housing having suitably accessible parking facilities.

INDUSTRY TIP

Chapter 52 and Appendix 5 of **BS 7671** provide a lot of detail relating to type of wiring and method of containment or support. Also refer back to Chapter 3 of this book, pages 203–9.

TYPES OF WIRING SYSTEM AND METHODS OF INSTALLATION

The type of wiring system and method of containment or support have to be carefully selected by the designer based on many influencing factors, which generally include:

- external influences – see below
- aesthetics – what it will look like
- longevity – how long it will last or need to last
- accessibility – can it be maintained
- utilisation – who is the user of the installation and is it suitable for their needs.

The major factor from the list above is external influences.

External influences

The wiring system must be able to withstand all the external influences it will be subjected to, including those listed in Table 5.4.

▼ Table 5.4 External influences on a wiring system

External influence	Example
Ambient temperature	The general constant temperature of the environment
External heat sources	Proximity to hot-water pipes and heaters
Water or high humidity	Immersed cables in a marina Condensation in an unheated building
Solid foreign bodies	Dust
Corrosive or polluting substances	Substances found in a tannery, battery room, plating plant, cowshed
Impact	Vehicles in a garage or car park
Vibration	Connections to motors
Other mechanical stresses	Bends too tight to pull in cables Insufficient supports
Presence of flora or mould	Plants or moss
Presence of fauna	Vermin Livestock
Seismic effects	In locations susceptible to earthquakes
Movement of air	Sufficient to stress mountings
Nature of processed or stored materials	Risk of fire Degradation of insulation, for example, from oil spills and acid in plating shops
Building design	From building movement

Table 5.5 lists the most common wiring systems or installation methods, the requirements for them and their common use.

▼ Table 5.5 Common wiring systems

Wiring system	Requirements	Common use
Clipped direct	Sheathed without armour	For general application in domestic and commercial installations. Not usually acceptable to the client in new installations. Mechanical protection may be required in some locations via the installation of guards or the use of armoured cable.
Clipped direct	Sheathed with armour	Commonly adopted in industrial premises where the presence of cables is acceptable.
Installed in the building structure	If using insulated and sheathed cables (that is, not armoured or enclosed in conduit, etc.), precautions must be taken to prevent damage	Insulated and sheathed cables installed in metal-framed walls will probably require additional protection.
Buried cables	Buried cables must be enclosed in a conduit or duct or be armoured. A sufficient depth is required to prevent damage by reasonably foreseeable disturbance to the ground	This is the most practical solution for large-sized cables for power distribution in a supply company network or between buildings.
Plastic conduit systems	A very wide range of plastic conduits is available. Suitable for almost every location	The manufacturer's instructions must be read to ensure that the conduit is suitable for the particular environment. Expansion needs to be allowed for.
Steel conduit systems	Common types are black enamel and galvanised. Stainless steel conduits may be specified for onerous locations	Galvanised is suitable for onerous environments and may be selected where the good mechanical properties are necessary.

▼ Table 5.5 Common wiring systems (continued)

Wiring system	Requirements	Common use
Cable-trunking systems	Insulated cables may be used (without sheath)	Used where several small cables need to be run.
Cable-ducting systems	The most practical system for distributing large cables through a building or site	Normally formed by concrete for large cables or circular pipe for smaller cables.
Cable ladder, cable tray, cable brackets	Cables need further mechanical protection by a sheath as this is not a containment system	A practical solution for distributing large cables around a building or site.
Mineral insulated	Specific skills are required to install these cables	These cables have exceptional fire-resistance properties and so are used for circuits requiring high integrity under fire conditions.
On insulators	Widely adopted for electricity supply distribution in rural areas	Cheaper than laying cables in the ground, but may be considered unsightly and are susceptible to damage by high vehicles. Care is necessary in some locations, e.g. caravan sites, riverbanks, farms, etc.
Support wire	Low cost and may avoid considerable disturbance	Check that the height is sufficient for all vehicle movements, etc.

PROTECTIVE EQUIPMENT

Generally, the first unit in an installation where the supply is split into circuits is called the consumer unit (CU). The CU will have protective devices inside, such as:

- circuit breakers (CBs)
- residual current breakers with overload (RCBOs)
- fuses.

These protective devices control and protect the circuits. We will explore them in more detail later in this chapter (also refer to Chapter 3, pages 190–95).

Consumer units or distribution boards (DBs) need careful selection, taking into consideration the material they are constructed from to comply with Regulation 421.1.201 where located in a domestic installation, and the number of circuits they are expected to control.

Consumer units or distribution boards

The CU will have a main switch that can be used to isolate the entire installation. In a domestic dwelling, the main switch must be double-pole, meaning it isolates both line and neutral. In some three-phase installations which are part of a TN earthing arrangement, the main switch in the DB may be three-pole, switching the three line conductors only. In this situation, the neutral can be isolated by a link.

Three-phase installations with a TT earthing arrangement must have four-pole switches isolating all live conductors.

The main switch in a CU within a house must be the type that is rated to switch the full load current. Some isolator devices which act as main switches within DBs are not rated for full load current switching and if they were used regularly to switch full load, they would eventually fail.

INDUSTRY TIP

You will hear consumer units being called many different things, including CUs, consumer control units, fuse boards, DBs and distribution boards.

A DB is classed by the amount of modules or ways it can take.

- Modules – the amount of components that can be fitted into the unit. For example, a main switch controls both line and neutral so is classed as a two-module device. A circuit breaker is single-pole, so one module. If you needed a DB to control six circuits and have a main switch, you would need an eight-module board.
- Ways – the amount of circuits that can be controlled. A six-way single-phase board could house six circuit breakers as well as the main switch. A six-way three-phase board can house six three-phase circuit breakers or 18 single-phase circuit breakers. It could also house a combination of the two, such as 2 × three-phase (six ways) and 12 × single-phase (12 ways).

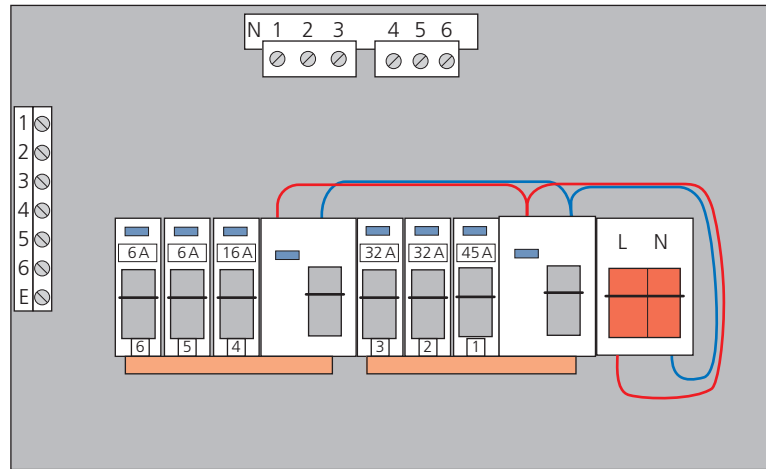

▲ Figure 5.6 Diagram of a split-way board showing three ways protected by one RCD and three ways protected by another. In total, the DB is 12-module

Some DBs are known as split-way boards. This means that some of the modules can be protected by one RCD or switch and the others by another RCD or switch. Split-way boards should always have one main switch that can isolate all circuits.

Circuit protection

The type of protective device chosen will depend on several factors, including:

- the nature or type of load
- the prospective fault current I_{pf} at that point of the installation
- any existing equipment, such as an existing DB that can only accept a certain type of device (providing it is suitable)
- the user of the installation, as a CB is easier to reset than a bolted-type high-rupturing capacity fuse.

▼ Table 5.6 Suitable devices for loads

Type of load	Suitable type of device
Resistive, such as heating elements, incandescent lighting, etc.	Type B circuit breakers gG BS 88 devices
Inductive, such as discharge lighting, small motors or extra-low voltage lighting transformers	Type C circuit breakers gM BS 88 devices
High inductive or surging, such as welding equipment, X-ray machines, large motors without soft starting	Type D circuit breakers

Protective devices are also selected for suitability against prospective fault current (PFC).

Breaking capacity

There is a limit to the maximum current that an overcurrent protective device (fuse or circuit breaker) can interrupt. This is called the rated short-circuit capacity or breaking capacity.

▼ Table 5.7 Rated short-circuit capacities of protective devices

Device type	Device designation	Rated short-circuit capacity (kA)	
Semi-enclosed fuse to BS 3036 with category of duty	S1A	1.0	
	S2A	2.0	
	S4A	4.0	
Cartridge fuse to BS 88-3	● Type I	16.0	
	● Type II	31.5	
General purpose fuse to BS 88-2		50 at 415 V	
		16.5 at 240 V	
		80.0 at 415 V	
Circuit breakers to BS EN 60898*		I_{cn}	I_{cs}
		1.5	(1.5)
		3.0	(3.0)
		6.0	(6.0)
		10.0	(7.5)
		15.0	(7.5)
		20.0	(10.0)
	25.0	(12.5)	

* Two short-circuit ratings are defined in BS EN 60898 and BS EN 61009

Notes:

I_{cn} is the rated short-circuit capacity (marked on the device); I_{cs} is the service short-circuit capacity. These are based on the condition of the circuit breaker after manufacturer's testing.

I_{cn} is the maximum fault current the breaker can interrupt safely, although the breaker may no longer be usable.

I_{cs} is the maximum fault current the breaker can interrupt safely without loss of performance.

The I_{cn} value is normally marked on the device in a rectangle, e.g. **6000**. For the majority of applications, the prospective fault current at the terminals of the circuit breaker should not exceed this value.

For domestic installations, the prospective fault current is unlikely to exceed 6 kA, up to which value the I_{cn} and I_{cs} values are the same.

Source: On-Site Guide, IET

Regulation 434.1 in **BS 7671** requires the prospective fault current under both short-circuit and earth-fault conditions to be determined at every relevant point of the complete installation. This means that at every point where switchgear is installed, the maximum fault current must be determined to ensure that the switchgear is adequately rated to interrupt the fault currents.

From Table 5.7, it can be seen that **BS 3036** devices have a very low breaking capacity compared with other devices. This is the main reason why these devices are no longer suitable for many installations.

Circuit breakers have two short-circuit capacity ratings.

- I_{cs} is the value of fault current up to which the device can operate safely and remain suitable and serviceable after the fault.
- I_{cn} is the value above which the device would not be able to interrupt faults safely. This could lead to the danger of explosion during faults of this magnitude or, even worse, the contacts welding and not interrupting the fault.

Any faults that occur between these two ratings will be interrupted safely but the device will probably require replacement.

Selectivity of protective devices

There will usually be several stages of protection in large systems. It is therefore necessary to ensure that series protective devices disconnect properly in order to avoid unnecessary disconnection of parts of the system not directly associated with the fault or overload. The system designer should therefore pay particular attention to selecting the appropriate type and rating of protective devices. This requires knowledge of the protective device performance characteristics, obtainable from manufacturers' published data sheets.

Regulation 434.5.1 in **BS 7671** requires any circuit protective device to have a fault rating at least as great as the fault level at its point of installation in a system. It does go on to state that a lower capacity device is permitted if there is back-up protection by a suitable device on the supply side of it.

If there is a fault in an installation, ideally only the equipment or cable that is faulty should be disconnected so that the remainder of the installation can continue to operate normally. It may be necessary to ensure continued functioning of the unaffected parts of the installation to prevent inconvenience or danger, such as a fault in a circuit causing lighting to be lost. By dividing the installation into circuits, including distribution circuits, we can minimise the chance of losing more than one section of an installation.

Effective selectivity is achieved when a designer ensures that local protective devices disconnect before others located closer to the origin of the installation. Selectivity is required:

- under normal load conditions
- under overcurrent conditions.

In the event of a fault, selectivity is desirable, but it may not be necessary if no danger and no inconvenience arise.

Fuse-to-fuse selectivity

Two fuses in series will discriminate between one another under overload and fault conditions if the maximum pre-arcing characteristic of the upstream device exceeds the maximum operating characteristic of the downstream device. Selectivity will be achieved for fuses if an upstream device is more than twice the rating of any downstream device. For example, if the upstream fuse (A) has a rating of 80 A and the local downstream fuse (B) is 32 A, selectivity would be achieved as neither of the characteristic curves cross one another. This is a simplistic way of checking selectivity and manufacturers should always be consulted.

INDUSTRY TIP

The 18th Edition of the IET Wiring Regulations now uses the term 'selectivity' instead of 'discrimination' but you will probably hear the word discrimination used for a few years to come.

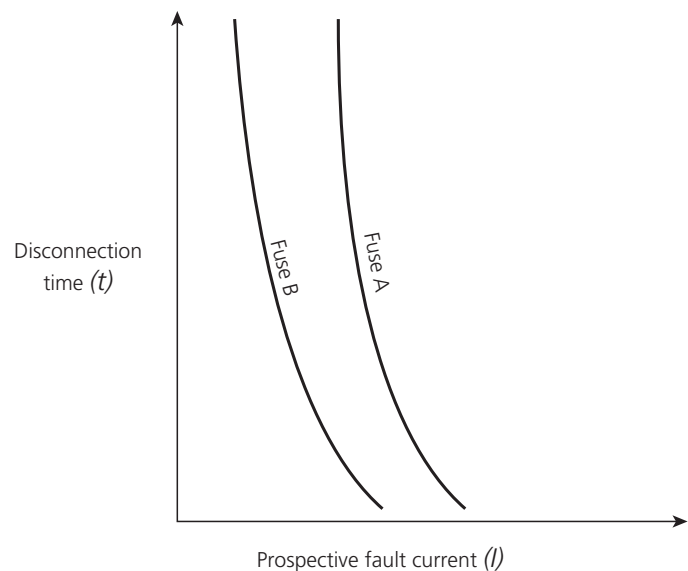

▲ Figure 5.7 Fuse characteristics

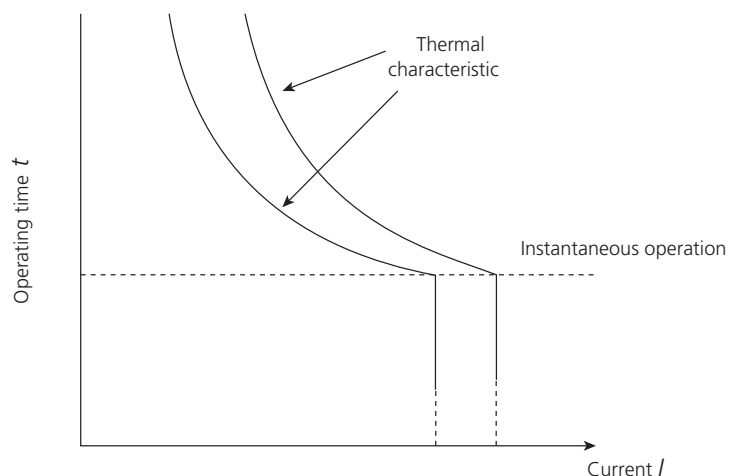

▲ Figure 5.8 Circuit-breaker characteristics

INDUSTRY TIP

Where two RCDs are in series, such as one at the origin of a TT installation and one on a circuit providing additional protection, the one installed at the origin should be time-delayed and have a residual current rating at least three times that protecting the circuit(s), as given in Regulation 536.4.1.4 of BS 7671.

INDUSTRY TIP

The term selectivity also relates to the short-circuit characteristics of a protective device to ensure that, if a fault current higher than the short-circuit capacity occurs, a device nearer the origin has a suitable short-circuit capacity to safely disconnect the fault before the local device is damaged.

Circuit breaker to circuit breaker

Circuit-breaker characteristics are different from those of fuses. The circuit breaker has two characteristic features:

- a thermal characteristic similar to a fuse
- a magnetic characteristic that, when at a specified current, causes the circuit breaker to operate instantaneously (see Figure 5.8).

If the fault current exceeds the instantaneous operating current of the upstream device, there may not be selectivity, whatever their ratings, as both devices may operate at the same time.

Manufacturers will provide information on circuit-breaker selectivity. In some situations, a local circuit breaker may be of a different type to one installed nearer the origin.

ACTIVITY

Look at Appendix 3 in BS 7671. We can see that a 32 A Type D circuit breaker will disconnect at a current of 640 A, whereas a 100 A Type B will disconnect at 500 A fault current. This means that the 100 A device will disconnect before the 32 A device.

Have a look at some other devices and make similar comparisons between high-current rated devices and lower ones.

Isolation and control

In Chapter 3 of this book, we looked at the need for isolation and switching in order to comply with the requirements of Chapters 46 and 53 in **BS 7671**, including why we install them and where.

A major consideration for any designer should be the suitability of the devices used as isolators or switches to control parts of an installation and their expected duty.

Devices selected for isolation or switching need to be rated for their particular expected use or located where use is restricted. If a device that is incorrectly rated is used for frequent switching, its terminals will degrade very quickly, leading to the risk of failure or fire.

If a device is selected that is not rated for frequent use, it should be installed in a location where access is by authorised persons, to minimise the risk of danger.

A sample of the switchgear usage category ratings and their typical uses is shown in Table 5.8 but more detail can be found in manufacturers' information.

▼ Table 5.8 Sample switchgear usage category ratings

Category for use		Typical uses
AC-20a	AC-20b	Connecting and disconnecting under no-load conditions
AC-21a	AC-21b	Switching of resistive loads, including moderate overloads

CIRCUIT DESIGN PROCEDURE

In this section we will look at two methods used to size live conductors. For the second method, we will also cover how protective conductors are selected.

Before we consider the procedures, we need to understand the terminology used.

Factors that affect design

There are several factors that impact on the effective current-carrying capacity of a conductor:

- conductor insulation
- ambient temperature
- thermal insulation
- grouping of circuits
- method of installation.

Conductor insulation

It is the conductor insulation that governs the overall capacity of a conductor, as it is the weak point. Copper can carry large currents before it reaches melting point but the insulation cannot. General thermoplastic insulation has a maximum operating temperature of 70°C, so it is this temperature that sets the current limit. It is assumed that the initial temperature of any conductor, and therefore insulation, is 30°C before any current is put through the conductor. As soon as current flows, the conductor temperature increases. The amount of current causing the temperature to reach 70°C is the upper limit of the conductor.

Looking at Table F6 in the IET On-Site Guide (reproduced as Table 5.9, below), it can be seen that a single-phase 4 mm² flat-profile cable installed in free air (method C, column 6) has a tabulated capacity of 37 A. This essentially means that, given no further influences, 37 A would cause the conductor's temperature to rise from 30°C to 70°C.

▼ Table 5.9 A selection of current-carrying capacity (amperes) and voltage drop (per ampere per metre): 70°C thermoplastic (PVC) insulated and sheathed flat cable with protective conductor (copper conductors), ambient temperature 30°C, conductor operation temperature 70°C for some reference methods

Conductor cross-sectional area	Reference method 100* (above a plasterboard ceiling covered by thermal insulation not exceeding 100 mm in thickness)	Reference method 101* (above a plasterboard ceiling covered by thermal insulation exceeding 100 mm in thickness)	Reference method 102* (in a stud wall with thermal insulation with cable touching the inner wall surface)	Reference method 103 (in a stud wall with thermal insulation with cable not touching the inner wall surface)	Reference method C (clipped direct)	Reference method A (enclosed conduit in an insulated wall)	Voltage drop
1	2	3	4	5	6	7	8
mm ²	A	A	A	A	A	A	mV/A/m
1	13	10.5	13	8	16	11.5	44
1.5	16	13	16	10	20	14.5	29
2.5	21	17	21	13.5	27	20	18
4	27	22	27	17.5	37	26	11
6	34	27	35	23.5	47	32	7.3
10	45	36	47	32	64	44	4.4
16	57	46	63	42.5	85	57	2.8

* Reference methods 100, 101 and 102 require the cable to be in contact with the plasterboard ceiling, wall or joist.

Source: Table F6, On-Site Guide, IET

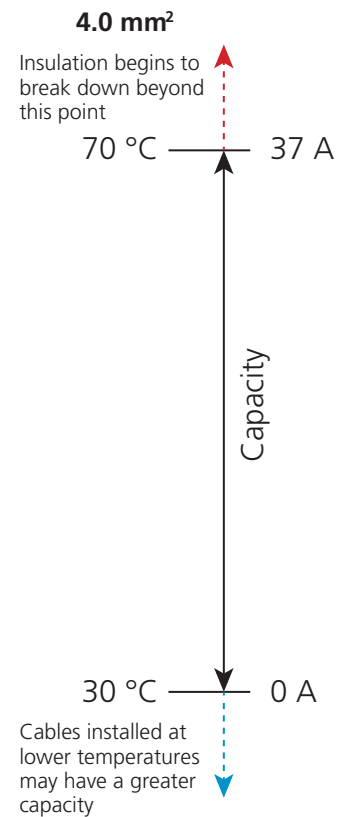

▲ Figure 5.9 PVC/PVC flat twin, 70°C thermoplastic, 30°C ambient temperature

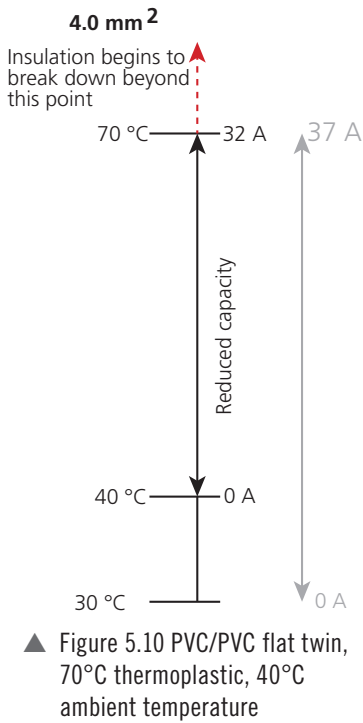

Ambient temperature

If cables are installed in ambient temperature other than 30°C, the capacity of the cable’s conductor is altered. If a cable were to be installed in an ambient temperature higher than 30°C, the capacity of the conductor would be reduced as the temperature of the cable, before any current flows, is higher. Rating factors (C_a) are used from Table 4C1 of **BS 7671** or Table F1 of the IET On-Site Guide.

These rating factors are used to alter the capacity of the conductor, depending on the ambient temperature of the cable and the type of insulation applied to the conductor. For any cable run which passes through a range of ambient temperatures, the highest shall be used to obtain a rating factor.

▼ Table 5.10 Ambient temperatures

Ambient temperature (°)	Insulation			
	70°C thermoplastic	90°C thermosetting	Mineral Thermoplastic covered or bare and exposed to touch 70°C	Mineral Bare and not exposed to touch 105°C
25	1.03	1.02	1.07	1.04
30	1.00	1.00	1.00	1.00
35	0.94	0.96	0.93	0.96
40	0.87	0.91	0.85	0.92

Source: Table F1, On-Site Guide, IET

INDUSTRY TIP

Do not apply rating factors for thermal insulation if method A or 100–103 is selected as the method of installation because thermal insulation is allowed for. These thermal insulation factors only really apply to method C or E to F (see page 292) where the cable is totally surrounded by thermal insulation.

Thermal insulation

Where a cable is totally surrounded by thermal insulation, the cable’s ability to dissipate heat is greatly reduced. As a result, rating factors for thermal insulation (C_i) need to be applied as the heat build-up in the cable will affect the temperature of the cable’s insulation. Ideally, thermal insulation should be avoided and cables should be clipped to a joist, or other thermally conducting surfaces, or should be sleeved by conduit as they pass through the thermal insulation. In these situations, a thermal insulation rating factor need not be applied as the current capacity is allowed for within the selection tables depending on the method of installation. Also, rating factors for thermal insulation do not need to be applied where conductors are greater than 10 mm².

As can be seen from Table 5.11 (below), a rating factor of 0.5 is applied to any cable which passes through 500 mm or more thermal insulation. This effectively reduces a conductor’s capacity by 50%, so thermal insulation is best avoided if possible. The values in this table are also shown in Appendix 4 of BS 7671.

▼ Table 5.11 Thermal insulation

Length in insulation (mm)	De-rating factor (C_i)
50	0.88
100	0.78
200	0.63
400	0.51
≥ 500	0.50

ACTIVITY

What is the difference between methods E and F (see page 292)?

Grouping of circuits

Where circuits are grouped together, either in the same containment system such as conduit, or clipped close together on a wall, the heat from one circuit can have an effect on others. Rating factors for grouping (C_g) are applied to circuits using Table F3 of the IET On-Site Guide (reproduced as Table 5.12, below) or Table 4C1 in **BS 7671**.

As can be seen from the tables, the more circuits that are grouped, the more the conductor's capacity is reduced. As an example, if a new circuit was installed into a cable basket with six other circuits, that would be seven in total. From the table, cables bunched in air (methods A to F) with a total number of circuits being seven has a rating factor of 0.54. This means that the conductor's capacity is reduced to 54% of the tabulated value.

Cables of similar size and type should be grouped together, as mixing of circuits means that Table 4C1 cannot be used and different calculations are required.

▼ Table 5.12 Grouping of circuits

Arrangement (cables touching)	Number of circuits or multi-core cables										Applicable reference method for current-carrying cables
	1	2	3	4	5	6	7	8	9	12	
Bunched in air, on a surface, embedded or enclosed	1.0	0.80	0.70	0.65	0.60	0.57	0.54	0.52	0.50	0.45	A to F (except those listed below)
Single layer on wall or floor	1.0	0.85	0.79	0.75	0.73	0.72	0.72	0.71	0.70	0.70	C
Single layer multicore on a perforated horizontal or vertical cable-tray system	1.0	0.88	0.82	0.77	0.75	0.73	0.73	0.72	0.72	0.72	E
Single layer multicore on a cable ladder system or cleats, etc.	1.0	0.87	0.82	0.80	0.80	0.79	0.79	0.78	0.78	0.78	E

Source: Table F3, On-Site Guide, IET

KEY FACT

Different calculations

Where a group contains a mixture of circuits of very different size and type – for example, a trunking (installed as method B) contains an 80 A distribution circuit, a 40 A final circuit and a 6 A lighting circuit – the group rating factor can be found using:

$$C_g = \frac{1}{\sqrt{n}}$$

Where n is the number of circuits in the group.

So using the above example, which has three circuits that are not similar, the grouping factor would be:

$$C_g = \frac{1}{\sqrt{3}} = 0.58$$

Whereas Table 4C1 or Table F3 would indicate a factor of 0.7 for three circuits grouped (as method B).

As a result, it is clearly beneficial to separate larger current circuits from smaller power circuits as the cables would require much harsher de-rating.

When using the table, consider:

- where the horizontal clearance between cables exceeds twice their diameter, no factor need be applied (for methods C, E and F)
- cables are assumed to be equally loaded. Where cables are expected to carry **no more than 30% of their grouped rating**, they may be ignored so far as grouping is concerned.

The IET On-Site Guide and BS 7671 contain more conditions regarding grouping.

30% grouped rating

Some cables, such as those for lighting circuits, may never be loaded at full capacity and where a cable does not carry a current larger than 30% of its **grouped rating**, it can be ignored for grouping purposes.

For example, a group of three single-phase circuits installed in trunking (method B) contained one circuit, which was expected to be wired in 1.5 mm² cable, and had a design current of 3 A.

The value of I_t for the 1.5 mm² cable is 17.5 A (from Table 4D1A) and the rating factor for three circuits is 0.7 from Table 4C1 or Table F3, so

As

$$17.5 \times 0.7 = 12.25 \text{ A}$$

12.25 A becomes its grouped rating, so

$$12.25 \times 0.3 \text{ (to find 30\%)} = 3.68 \text{ A}$$

The design current for this circuit is 3 A and therefore less than 30% of the cable's grouped rating.

As a result of this, this circuit can be ignored as part of the group and therefore the remaining cables in the group can use a rating factor based on two circuits.

KEY TERM

Methods of installation:

– detailed in two ways:

- Reference methods, which are the letters given in the right-hand column of Table 4A2 in BS 7671
- Installation methods, which are the numbers on the left-hand side of the same table.

Most of the time when the term 'method' is used it refers to the letter, with the exception of flat-profile cables when they are installed above ceilings or in stud walls. In this situation, the Installation method number is used.

ACTIVITY

Determine if the following **four** circuits, wired in non-sheathed, single-core cable, installed in a trunking, would need to be considered or excluded from grouping.

- 4 mm² cable with a design current of 12 A
- 2.5 mm² cable with a design current of 9 A
- 2.5 mm² cable with a design current of 5 A
- 1.5 mm² cable with a design current of 2 A.

Method of installation

Basic **methods of installation** are listed below but for a complete list, see Table 4A2 in Appendix 4 of **BS 7671**. The method used to install cables can affect the ability of a cable to dissipate heat, meaning that cables could run too hot if the correct method or table selection is not considered.

When selecting a conductor csa from the relevant current-capacity table, each column represents a different method of installation. The common methods include:

- **Method A:** enclosed in conduit in an insulated wall.
- **Method B:** enclosed in surface-mounted conduit.
- **Method C:** clipped directly to a surface in free air.
- **Method 100:** in contact with wooden joists or a plaster ceiling and covered by thermal insulation *not exceeding* 100 mm thickness.
- **Method 101:** in contact with wooden joists or a plaster ceiling and covered by thermal insulation *exceeding* 100 mm thickness.
- **Method 102:** in a stud wall containing thermal insulation with the cable touching the wall.
- **Method 103:** in a stud wall containing thermal insulation with the cable *not* in contact with the wall.

Simple single-circuit method of circuit design

This method is suitable for most situations and particularly suited to sizing a single circuit where voltage drop should not be an issue. If voltage drop does prove to be a problem, this method may require several repetitive calculations. This method was commonly used when BS 3036 devices were popular, as the only way to apply the factor of 0.725 for this type of device is as a divisor, dividing it into the fuse nominal rating (I_n). As BS 3036 fuses are rarely used today, this method does not need to be applied.

In order to determine a suitable conductor csa for a single-circuit cable, the following procedure is used.

Determining a suitable conductor csa for a single-circuit cable step by step

Step 1

Determine the design current (I_b). This is determined in several ways depending on the type of load and the allowance, if any, for diversity.

▼ Table 5.13 How to determine design current for simple single-phase final circuits

Load type and nature of the final circuit	How to determine design current (I_b)	Notes
Standard resistive loads, such as water heaters, electric space heaters and incandescent lighting	$I_b = \frac{\text{total watts}}{\text{volts}}$	For ceiling roses and similar in dwellings, each point is assumed as 100 W. See Table A1, IET On-Site Guide
Socket-outlet circuits, such as radial or ring-final circuits	$I_b = I_n$	Where I_n is the rating of protective device
For discharge lighting, such as circuits containing many fluorescent luminaires	$I_b = \frac{\text{total watts} \times 1.8}{230}$	The factor of 1.8 allows for increased current during starting, which all cables and switching devices must be capable of handling
For inductive loads where power factor is known, such as motors	$I_b = \frac{\text{total watts}}{\text{volts} \times \cos \theta}$	Where $\cos \theta$ is the power factor
Domestic cooker circuits	$I_b = \left(\frac{\text{total watts}}{\text{volts}} - 10 \right) \times 0.3 + 10$	See Table A1, IET On-Site Guide Add 5 A if the cooker control incorporates a socket outlet
Others	See Table A1, IET On-Site Guide	

Step 2

Select the nominal rating of protective device (I_n).

$$I_n \geq I_b$$

Step 3

Gather information, such as the following.

- Circuit length: this is the full length of the circuit from the distribution board to the final point of use on the circuit, in metres.
- Method of installation: see Table 4A2 in BS 7671 or Section 7 of the IET On-Site Guide.
- Rating factor for ambient temperature (C_a): see Table B1 in BS 7671 or Table F1 in the IET On-Site Guide.
- Rating factor for thermal insulation (C_i): see Table 52.2 in BS 7671 or Table F2 in the IET On-Site Guide.
- Rating factor for grouping of circuits (C_g): see Table 4C1 in BS 7671 or Table F3 in the IET On-Site Guide.
- Rating factor to be applied if the protective device is a **BS 3036** semi-enclosed fuse (C_f) = 0.725.
- Rating factor for soil thermal resistivity (for buried cables) (C_s): see Table 4B3 in BS 7671.
- Rating factor for depth of burial of a cable in the soil (C_d): see Table 4B4 in BS 7671.
- Rating factor for cables buried in the ground: $C_c = 0.9$.

Step 4

Apply the following calculation:

$$I_t \geq \frac{I_n}{C_a \times C_g \times C_s \times C_d \times C_c \times C_i \times C_f}$$

Where I_t is the tabulated current-carrying capacity specified (see step 5).

Note: any factor which is not applicable or 1 may be ignored.

Step 5

Use the correct table from **BS 7671: 2018 (2022)** The IET Wiring Regulations, 18th Edition or the On-Site Guide; see Table 5.14 (below).

▼ Table 5.14 Which table to use for current-carrying capacity

BS 7671 tables	On-Site Guide tables
<ul style="list-style-type: none"> ● Table 4D1A for single-core cables having 70°C thermoplastic insulation ● Table 4D2A for multi-core cables (non-armoured) having 70°C thermoplastic insulation ● Table 4D5 for multi-core flat-profile cables having 70°C thermoplastic insulation ● Table 4D4A for multi-core thermoplastic 70°C armoured cable (steel-wire armoured) 	<ul style="list-style-type: none"> ● Table F4(i) for single-core cables having 70°C thermoplastic insulation ● Table F5(i) for multi-core cables (non-armoured) having 70°C thermoplastic insulation ● Table F6 for multi-core flat-profile cables having 70°C thermoplastic insulation.

Select, using the correct column number relating to the installation method, a value of tabulated current **equal to or larger than** that calculated in step 4.

This will now ensure that the cable selected is of suitable current-carrying capacity.

Step 6

Taking voltage drop into account, ensure that the selected csa of the conductor is appropriate. For the cable csa selection tables used in step 5, each has a corresponding voltage-drop table or column.

The values given in these tables or columns represent the value of voltage drop, in millivolts per ampere per metre of circuit (mV/A/m).

The circuit length determined in step 3 is required to determine voltage drop but remember that the circuit (cable) length is the length of the line conductor with the neutral, not added to the neutral. For example, if a twin cable has a cable length of 10 m, that is the length of the line with neutral.

The line added to the neutral would be 20 m (there and back). The values of voltage drop per metre include the neutral resistance within the values.

Apply the following formula to determine the value of voltage drop:

$$\frac{\text{mV/A/m} \times \text{length} \times \text{design current } (I_b)}{1000} = \text{voltage drop}$$

Currently, Appendix 4 of **BS 7671** states that values of voltage drop for an installation supplied from a public network should not exceed:

- 3% of the supply voltage for lighting circuits (3% of 230 V = 6.9 V)
- 5% of the supply voltage for power circuits (5% of 230 V = 11.5 V).

As long as the voltage drop calculated for the selected cable csa is within the values above, the cable selected is suitable. If the calculated voltage drop is too high, the next largest csa is selected and calculated for voltage drop until a suitable csa is found.

INDUSTRY TIP

If a final circuit is supplied by a distribution circuit, the voltage drop for the distribution circuit will also need to be taken into account.

IMPROVE YOUR MATHS



Example for the circuit design procedure

A radial power circuit is to be installed in a surface-mounted trunking that contains four other circuits. The circuit is to be wired using single-core 70°C thermoplastic-insulated cable with copper conductors. The circuit is 15 m in length.

The design current for the single-phase circuit (I_b) is 17 A and the ambient temperature is 25°C. Protection against overload and short circuit is by a Type B circuit breaker to **BS EN 60898**. As $I_n \geq I_b$, then a 20 A device is selected.

Using the information contained in Appendix 4 of BS 7671, the installation method is reference B from Table 4A2.

$C_a = 1.03$ from Table 4B1 for 25°C and thermoplastic cable

$C_g = 0.6$ from Table 4C1, given the number of circuits is five in total, installed as method B

$C_i = 1$ as no thermal insulation exists

$C_f = 1$ as the device is *not* to **BS 3036**.

INDUSTRY TIP

Other rating factors do not apply so they too would be 1, which means they are not applicable.

ACTIVITY



Determine a suitable csa of conductors for current-carrying capacity and voltage drop for the following example.

A circuit is to be installed to supply a 230 V, 3 kW immersion heater. The circuit is to be wired in flat-profile 70°C thermoplastic cable where the majority of its 17 m length will be installed above a ceiling having < 100 mm of thermal insulation above it (note: it is installed under the thermal insulation, which has a bearing on the method. It is not totally surrounded by thermal insulation, so C_i for thermal insulation does not apply and would therefore be 1.) The cable is not grouped with any other circuit.

The ambient temperature is 35°C and protection is by an RCBO to **BS 61009**.

As:

$$I_t \geq \frac{I_n}{C_a \times C_g \times C_i \times C_t}$$

Then:

$$I_t \geq \frac{20}{1.03 \times 0.6 \times 1 \times 1}$$

Remember, any value of 1 may be ignored so:

$$I_t \geq \frac{20}{1.03 \times 0.6} = 32.36 \text{ A}$$

So, using the correct cable selection table for single-core 70°C thermoplastic cable from Appendix 4 of BS 7671, we can select a conductor cross-sectional area (csa). Using Table 4D1A, in particular column 4 as the circuit is single-phase and the method is B, the value of I_t suitable for the current calculated is 41 A, which indicates a 6 mm² conductor size.

Now we confirm the cable for voltage drop by:

$$\frac{\text{mV/A/m} \times \text{length} \times \text{design current } (I_b)}{1000} = \text{voltage drop}$$

So from Table 4D1B, column 3 for single-phase method A and B, select a value of mv/A/m of 7.3 for a 6 mm² conductor:

$$\frac{7.3 \times 17 \times 15}{1000} = 1.86 \text{ V}$$

The maximum voltage drop is 5% of the supply voltage, so:

$$\frac{230 \text{ V} \times 5}{100} = 11.5 \text{ V}$$

As the voltage drop for this power circuit is less than 11.5 V, this is acceptable. Remember to use brackets on your calculator when you input the bottom line. For example, if brackets are not used on the bottom line of a calculation, the formula

$$\frac{20}{1.03 \times 0.6}$$

becomes

$$\frac{20}{1.03} \times 0.6 = 11.65$$

and is incorrect, so

$$\frac{20}{(1.03 \times 0.6)} = 32.36$$

which is correct.

Also remember that any number multiplied or divided by 1 remains unchanged, so any value that is 1 can be disregarded in the calculation.

Design grid method for circuit design

Why use the grid method? When determining the csa of conductors for multiple circuits, the grid method is more efficient. If you are looking up rating factors for grouping for one circuit, you may as well stay on that table and find them for 20 circuits. It saves a lot of time.

More importantly, this method of using the rating factors as multipliers is the only way to determine a value of I_z and some regulations in BS 7671 require the I_z value to be determined or compared with.

Also, in certain circumstances, voltage drop may be the key factor that determines a cable csa because:

- distribution circuits have consumed voltage, so the voltage drop limits are smaller
- designers may set lower voltage-drop tolerances in order to save energy losses as *voltage loss contributes towards power loss*
- specific equipment may have voltage requirements that require less voltage loss
- the installation has an actual low supply voltage so, by design, voltage loss is minimised.

Within the grid, each column is given a number and the formula used in each case relates to the column number values.

In addition, the grid is used to determine the csa of circuit protective conductors (cpc) for suitability for earth fault loop impedance and thermal constraints.

The grid is a useful way to present and easily see the information for each circuit, just like a schedule of test results is easy to understand. We will be using one sample grid but there is nothing to stop you from making your own version.

Completing the grid for live conductors

The calculations that need to be made in order to complete the grid are multiple and often look complex. Looking at the grid in Figure 5.11a, you can note that each calculation has a number attached to it (e.g. calc 1): these indicate the order in which the calculations should be made or followed.

You will see as we work through, that the formula includes wording in brackets, such as (col 1). This indicates you use the value from the column number for that value in the calculation.

For example, where a calculation is required for column 12 (in yellow in Figure 5.11b), it shows you use calc (calculation) 2. Calculation 2 is:

$$\text{max mV/A/m} = \frac{\text{max volt drop (col 11)} \times 1000}{I_b(\text{col 2}) \times \text{length (col 10)}}$$

So this would involve values being inputted into the formula from columns 11, 10 and 2 (in green).

Also note, where the word 'stated' is used, this would be a value from information or tables. Each step will explain the necessary values and where to find them.

INDUSTRY TIP

Look at the opening paragraphs for Section 5 in Appendix 4 of BS 7671. It states there that the multiplier method is the method to use except for when BS 3036 fuses are used, where it is more convenient to use the divisor method. It also clearly states that using the divisor method does not provide a value of I_z .

	Circuit number		1	2	3	4	5	6	7	8
1	Watts	stated								
2	I_b design current	Calc 1 or known								
3	I_n device rating	select								
4	Method of installation	Table 4A2								
5	Ambient temp in °C	stated								
6	Cable type/insulation	stated								
7	C_a ambient temp. factor	Table 4B								
8	C_g grouping factor	Table 4C or $\frac{1}{\sqrt{n}}$								
9	C other factors that may be applicable	stated								
10	Length in metres	stated								
11	Max. Volt Drop	stated								
12	mV/A/m max.	Calc 2								
13	Size selected mm ² based on col 12 as suitable for voltage drop	Table 4D-								
14	It/csa	Table 4D--								
15	I_z (must be larger than I_n)	Calc 3								
16	Max. Disc. time	Table 41.1								
17	Max. Z_s	Table 41—								
18	OSG Table I3 factor	OSG								
19	Max. R_1+R_2 in mΩ/metre	Calc 4								
20	CPC size (from OSG Table I1 or as given by cable size)	OSG Calc 5 or stated								
21	Actual R_1+R_2	Calc 6								
22	Actual Z_s	Calc 7								
23	Actual fault current (at 230 V)	Calc 8								
24	Actual Disc. Time	App 3								
25	k values	Table 54.2								
26	Thermal constraint minimum csa	Calc 9								
		$Z_e =$								

▲ Figure 5.11a Sample grid

The sample design grid is in two parts:

- sizing live conductors (columns 1 to 15)
- sizing of protective conductors and calculating earth fault loop impedance (columns 16 to 26).

We still need to apply knowledge learnt from the single-circuit method, such as why we apply rating factors and where to find them.

2																
1																
	stated	Calc 1 or known	select	Table 4A2	stated	stated	Table 4B	Table 4C or $\frac{1}{\sqrt{n}}$	stated	stated	stated	Calc 2	Table 4D-			
Circuit number	Watts	I_b design current	I_n device rating	Method of installation	Ambient temp in °C	Cable type/insulation	Ca ambient temp. factor	Cg grouping factor	C other factors that may be applicable	Length in metres	Max. Volt Drop	mV/A/m max.	Size selected mm ² based on col			
1																
2																
3																
4																
5																
6																
7																
8																
9																
10																
11																
12																
13																

▲ Figure 5.11b Design grid sample

Calculating the csa of live conductors

The numbered points below refer to the column numbers in the sample grid and each has an explanation of what to insert in each case. In this section, we will cover columns 1–15 for live conductors.

- 1 Insert the value of watts or kVA for the load. If there is no value to work with because you know the design current, leave this column blank.
- 2 Determine I_b using one of the following formulae depending on the type of circuit and the type of load. If the design current is known, simply insert it. Whichever formula is suitable would be *calculation 1* in the design grid and each formula is based on:
 - Single-phase loads specified in watts and, where applicable, power factor¹
 - Single-phase discharge lighting loads
 - Three-phase balanced loads
 - Socket-outlet circuits where the circuit is governed by the protective device as the actual loading is unknown, or where the loading can be assumed based on the type of installation and its anticipated use.

- For standard loads:

$$I_b = \frac{\text{watts (col 1)}}{\text{volts} \times \text{power factor}}$$

- For discharge lights²:

$$\frac{\text{watts (col 1)}}{\text{volts}} \times 1.8$$

- For three-phase circuits having balanced loads:

$$I_b \text{ per line} = \frac{\text{watts (col 1)}}{\sqrt{3} \times 400 \times \text{pf}}$$

- For socket-outlet circuits: $I_b = I_n$

Or, apply diversity where you can determine an actual steady load.

For example, if socket outlets are intended for some chargers or laptops only,

I_b may be assumed to be 4 A in normal conditions.

Note 1: Power factor is only applicable for inductive loads (see Chapter 2 of this book, pages 98–102).

Note 2: The 1.8 factor for discharge lighting is to accommodate in-rush start-up current. See notes under Table A1 in the IET On-Site Guide. Other lighting, such as LED lighting, would not require the 1.8 factor but manufacturer's information should be looked at as some LED drivers may have in-rush start-up currents.

3 Once the I_b is determined, determine I_n , where $I_n \geq I_b$

Do not be afraid to select a value of I_n close to the design current as the nominal rating (I_n) is the current the device can work at continuously without deterioration. For example, if a design current was calculated to be 19 A, select a 20 A device rating.

4 Insert the method of installation number or reference letter from Table 4A2 of BS 7671.

5 Insert the actual ambient temperature.

6 Insert the cable type used or some form of abbreviation that you will know it by; this may be PVC/PVC for sheathed cable or, if you prefer, you can insert the table number from BS 7671 that relates to the cable-current capacity. For example, inserting 4D1A relates the cable to thermoplastic single-core, non-sheathed cable.

7 Insert the rating factor for ambient temperature, which is found in Table 4B in BS 7671.

8 Insert the rating factor for grouping, which is found in Table 4C of BS 7671.

9 Insert here any other rating factors that may apply. Grouping and ambient temperature are the most common ones (above) but other rating factors may apply, such as thermal insulation (C_i) or circuits buried in the ground (C_g).

10 Insert the circuit length.

11 Maximum voltage drop is inserted here and that may be based on permitted values, as given in Appendix 4 of BS 7671, for a public supply, which are:

- 3% of the supply voltage for lighting circuits (3% of 230 V = **6.9 V**)
- 5% of the supply voltage for power circuits (5% of 230 V = **11.5 V**)

Alternatively, the voltage drop may be limited because a distribution circuit supplies a distribution board (DB) and the final circuits on the DB must allow for the voltage drop in the distribution circuit.

If a lighting circuit supplied from a particular DB is allowed a voltage drop up to 3% of the supply voltage (6.9 V is 3% of a 230 V supply), but the DB is supplied by a distribution circuit which has a designed voltage drop of 2 V, that only leaves 4.9 V permitted for the final lighting circuit. In this situation, 4.9 V would be the maximum voltage drop that is inserted in column 11.

12 Determine the maximum mV/A/m that is permitted based on the maximum voltage drop.

A cable csa can be selected based on this value as long as the value in the table is less than the calculated value.

INDUSTRY TIP

Remind yourself of the formula that was used to determine the rating factor for grouping, where circuits installed in the same containment system were not similar in rating.

In the single-circuit method, we calculated actual voltage drop, using:

$$\frac{\text{mV/A/m} \times \text{length} \times \text{design current } (I_b)}{1000} = \text{voltage drop}$$

So if we transpose this formula to:

$$\text{max mV/A/m} = \frac{\text{voltage drop} \times 1000}{I_b \times \text{length}}$$

we can determine the maximum permissible value of mV/A/m and base our initial conductor csa on this.

That way, whatever conductor we end up using, as long as it is the same csa or larger, it will be suitable for the maximum voltage drop permitted or required. After a suitable cable has been selected, voltage drop can then be confirmed. This is because the conductor selected will be suitable and any larger csa we may select for current capacity will certainly be suitable as the voltage drop will only reduce in value the larger csa of conductor we select.

To determine the maximum mV/A/m, apply:

$$\text{max mV/A/m} = \frac{\text{max voltage drop (col 11)} \times 1000}{I_b \text{ (col 2)} \times \text{length (col 10)}}$$

The value of mV/A/m is recorded in column 12.

- 13 Then, go to the voltage drop tables and select a cable having an mV/A/m **lower** than this calculated value.

For example, if the calculation produced a result of 10 mV/A/m and a single-core thermoplastic cable was to be installed, Table 4D1B is the table we would use for voltage drop. If the circuit was single-phase as method B, we would look at column 3 and select a 6 mm² conductor as it has 7.3 mV/A/m voltage drop and this is less than 10 mV/A/m.

That way, we can be confident that voltage drop has been verified as suitable, as long as a 6 mm² conductor is used or larger.

- 14 Now the cable csa has been selected as the minimum size suitable for voltage drop, it must be proven for current-carrying capacity.

A quick first check is to compare the value with the rating of protective device (I_n) as in column 3. If the value of I_t is less than the value of I_n , it will not be suitable as the cable will not be protected, so a value of I_t larger than I_n needs to be selected and confirmed.

For example: Following a voltage drop calculation, a 2.5 mm² cable is selected with an I_t value (from Table 4D1B, column 4 of BS 7671) of 24 A.

As I_t is higher, this would be initially suitable and can be inserted into column 14 but it needs to be proven for current-carrying capacity under the **circuit installation conditions** using the rating factors by carrying out calculation 3 in column 15.

20	(2.5) 24
select	Table 4D--
I_n device rating	I_t /csa
3	14

▲ Figure 5.12 Example table rows

ACTIVITY

If a single-phase power circuit is supplied from a distribution circuit, and the distribution circuit has a calculated voltage drop of 4 V, what is the maximum allowed voltage drop for the power circuit supplied from it?

INDUSTRY TIP

Just a reminder where the cable-selection tables are in **BS 7671**:

- Table 4D1A/B for single-core cables having 70°C thermoplastic insulation
- Table 4D2A/B for multi-core cables (non-armoured) having 70°C thermoplastic insulation
- Table 4D5 for multi-core flat-profile cables having 70°C thermoplastic insulation
- Table 4D4A for multi-core thermoplastic 70°C armoured cable (SWA).

KEY TERM

Circuit installation conditions: The conditions that require rating factors, such as C_a , C_g , etc.

KEY FACT

Remember, only use the rating factors that apply. If they do not apply, they have a value of 1 and multiplying a value by 1 means it stays the same.

INDUSTRY TIP

We will return to columns 17–26 of the design grid for protective conductors later in this chapter.

15 To prove the cable csa and I_t is suitable for current-carrying capacity, calculation 3 is carried out:

$$I_z = I_t \times C_a \times C_g \times C_{\text{other}}$$

where:

- I_t is the value from column 14
- C_a is the rating factor for ambient temperature from column 7
- C_g is the rating factor for grouping from column 8
- C_{other} is any other rating factors that may apply from column 9.

The result from the calculation is I_z , which is defined by BS 7671 as the 'current carrying capacity of a cable for continuous service under the particular installation conditions concerned'.

I_z must be larger or equal to I_n to satisfy current capacity and the resulting I_z , if suitable, can be entered into column 15.

Once this part of the grid has been completed, the live conductors have been suitably sized; so a quick check, to ensure correct coordination for the circuit can be carried out to ensure:

$$I_b \leq I_n \leq I_z$$

If they all coordinate, the circuit is suitable.

ACTIVITY



We will use a worked example for the design grid later in this chapter, but as practice in working with the grid, try sizing a suitable live conductor csa for the following circuit.

A circuit is to be installed to supply a 230 V single-phase 3.6 kW heater and is to be wired using single-core non-sheathed 70°C thermoplastic cable in surface conduit for its 22 m length. Ambient temperature is 35°C and the circuit is to be protected by a **BS EN 60898** Type B circuit breaker. The conduit will contain one other similar circuit (so two in total).

1	3.6	15.7	16	B	35	70°C PVC singles	0.94	0.8	-	22	11.5	34	1.5 (29)	24 2.5	18
Circuit number	Watts	I_b design current	I_n device rating	Method of installation	Ambient temp in °C	Cable type/insulation	C_a ambient temp. factor	C_g grouping factor	C other factors that may be applicable	Length in metres	Max. Volt Drop	mV/A/m max	Size selected mm ² based on col 12 as suitable for voltage drop	I_t /csa	I_z (radial: must be larger than I_n or, ring: greater than 20 A)
1	3600	15.7	16	Table 4A2	35	70°C PVC singles	0.94	0.8	-	22	11.5	34	1.5 (29)	24 2.5	18

▲ Figure 5.13a Design grid for worked example

From the grid, a 1.5 mm² cable would be suitable for voltage drop but it would not be suitable for current-carrying capacity as the I_z based on a 1.5 mm² cable is 13.2 A, which is lower than 16 A (I_n). As a result, a 2.5 mm² cable was selected and proven as being suitable as 18 A (I_z) is larger than 16 A.

Where the suitability of a ring-final circuit is being undertaken, the I_z calculated must be greater than 20 A in accordance with regulation 433.1.204.

The maximum voltage drop in mV/A/m is calculated using the entire ring loop length. The max mV/A/m derived from the calculation is then divided by 4 and the resulting value used to select a cable csa.

EXAMPLE: RING-FINAL CIRCUIT CALCULATION

A ring-final circuit has the following conditions:

- estimated design current (I_b) is 22 A
- protective device is a 32 A Type B circuit breaker
- the circuit has a 58 m loop circuit length meaning this is the length of cable leaving the DB, supplying each socket outlet and returning to the DB
- wired using single-core 70°C thermoplastic cables in surface trunking.

We need to allow for two circuits grouped.

Ambient temperature is taken as 25°C.

Because a ring-final circuit cable shares the load through parallel conductors, Regulation 433.1.204 in BS 7671 requires the chosen conductors, after all conditions are taken into account, to have a capacity no less than 20 A.

As the circuit is installed in surface trunking, the reference installation method is B.

The ambient temperature is 25°C and from Table 4B1 in BS 7671, this has a factor C_a of 1.03. From Table 4C1, the factor C_g for two circuits grouped as method B (A-F) is **0.8** so

$$\frac{20}{(1.03 \times 0.8)} = 24.27 \text{ A}$$

From Table 4D1A of BS 7671, as it is single-core thermoplastic cable, single-phase method B (column 4), a cable that has a tabulated value exceeding this is **4 mm²** with a value of 32. The 2.5 mm² cable is quite close to call and so going by the calculation that the minimum exceeds 24 A, this would not be acceptable.

Alternatively, another suitable method to determine the minimum value is to take the value of I_t such as 24 A for the 2.5 mm² conductor and apply the factors as multipliers to find the actual I_z rating of the cable. Remember the two rating factors needed are 1.03 (C_a) and 0.8 (C_g).

$$24 \times 1.03 \times 0.8 = 19.78 \text{ A}$$

As this is less than 20 A as given in Regulation 433.1.204, this is not acceptable so a **4 mm²** conductor is selected and

$$32 \times 1.03 \times 0.8 = 26.37 \text{ A}$$

As this is greater than 20 A, this is acceptable.

To calculate the overall voltage drop: the value of mV/A/m for a 4 mm² conductor from Table 4D1B is 11 mV/A/m so voltage drop is

$$\frac{(11 \times 22 \times 58)}{1000} = 14.04 \text{ V}$$

but as it is a ring and the conductors are in parallel

$$\frac{14.04}{4} = 3.51 \text{ V}$$

INDUSTRY TIP

You should have studied Chapter 3 of this book and have access to **BS 7671** and the IET On-Site Guide to understand and carry out these cpc calculations.

Considering circuit protective conductors

Circuit protective conductors (cpc) need to be sized correctly for two reasons:

- To ensure that the total earth fault loop impedance (Z_s) is low enough to cause disconnection of the protective device and therefore be in accordance with Tables 41.2, 41.3 and 41.4 of BS 7671
- To ensure that the cpc can withstand the high fault current in the time it takes the protective device to disconnect without the conductor exceeding its final limiting temperature (the point at which the insulation melts). To prove this, the cpc must be larger than the result of the adiabatic equation as represented in Chapter 54 of BS 7671.

Before we continue with the calculations in the grid, we will once again look at how these values are designed.

Total earth fault loop impedance (Z_s) is the combination of the supply loop impedance external to the installation (Z_e) and the resistance of the circuit line (R_1) and cpc conductors (R_2) so:

$$Z_s = Z_e + R_1 + R_2$$

Where:

- Z_s is the total earth fault loop impedance
- Z_e is the impedance of the supply loop external to the installation
- R_1 is the resistance of the line conductor(s) in the installation
- R_2 is the resistance of the cpc conductor(s) in the installation.

In order to determine the $R_1 + R_2$ values, the following information is required:

- cable length
- cable conductor csa
- cable insulation, which affects the maximum operating temperature of the conductors
- how the cable is installed or arranged
- values of $m\Omega/m$ at 20°C from Table I1 in the IET On-Site Guide.

Table I1 in the IET On-Site Guide gives values of $R_1 + R_2$ resistance for a 1 m section of cable at a temperature of 20°C . As the live conductors within a cable will rise in temperature as current passes through them, the operating temperature of the live conductors will have an effect on the temperature of the cpc depending on how the cpc is installed. If the cpc is bunched against the live conductors, such as the cpc in a flat-profile twin and cpc cable, the cpc will rise significantly in temperature compared with one that is run separately.

To allow for a rise in temperature, and therefore a rise in resistance of the $R_1 + R_2$, which in turn will increase the value of Z_s , a **factor** needs to be applied.

Factor

A factor is used to design a circuit $R_1 + R_2$ to allow for operational temperatures; it is referred to as **the table I3 factor**. This factor allows for the rise in temperature a cpc reaches during the normal operation of the live conductors. This is dependent on how the cpc is situated in relation to the live conductors, as it is the

live conductors that generate the heat. The factor is also dependent on the type of insulation. See Table 5.15 for the factor applied.

▼ Table 5.15 Factors dependent on type of insulation

How the cpc is installed in relation to the live conductors	Factor	
	Insulating material being thermoplastic 70°C	Insulating material being thermosetting 90°C
Cables not bunched or incorporated into the cable: Examples: cpc tied to an SWA cable as an overlay; MICC cable sheath, single-core cables installed as method C, or method F providing the cable has mechanical protection	1.04	1.04
Cables are bunched or incorporated into the cable: Examples include the cpc installed as reference method B or the cpc is incorporated into a multi-core composite cable	1.2	1.28

With the necessary circuit information and factors, $R_1 + R_2$ for a circuit can be calculated by applying:

$$R_1 + R_2 = \frac{\text{m}\Omega/\text{m} \times \text{length} \times I_3 \text{ factor}}{1000}$$

where:

- $\text{m}\Omega/\text{m}$ is the value obtained from Table I1 of the IET On-Site Guide
- Length is the length of the cable in metres
- I_3 factor is the factor from Table I3 of the IET On-Site Guide
- 1000 is used to ensure the end result is in ohms, not milli-ohms.

Example: Calculating $R_1 + R_2$ for a circuit

Determine the $R_1 + R_2$ at operating temperature for a circuit wired in 4/1.5 mm² flat-profile twin and cpc cable having 70°C thermoplastic insulation. The circuit is 27 m in length.

Gather the following information:

- Table I1 value in $\text{m}\Omega/\text{m}$ for a 4/2.5 combination of conductors = 16.71
- Table I3 factor based on the cpc being incorporated into the 70°C thermoplastic cable = 1.2

So as:

$$R_1 + R_2 = \frac{\text{m}\Omega/\text{m} \times \text{length} \times I_3 \text{ factor}}{1000}$$

Then:

$$R_1 + R_2 = \frac{16.71 \times 27 \times 1.2}{1000} = 0.54 \Omega$$



ACTIVITY



What is the maximum Z_s permitted for a 16 A final circuit supplying a fixed heater and protected by a **BS 88-2** device?

Tip: a final circuit rated less than 32 A and supplying a fixed load must disconnect in 0.4 seconds. This was covered in Chapter 3 of this book.

IMPROVE YOUR MATHS



Determine the $R_1 + R_2$ for a circuit wired using 1.5 mm² 90°C thermosetting single-core non-sheathed cable wired in conduit for a length of 31 m. The cpc is the same csa as the live conductors.

INDUSTRY TIP

Always remember that the Z_e is the value of external loop impedance of the supply up to the origin of the circuit. If a circuit Z_s needs to be calculated and that circuit is supplied from a distribution board (DB) that is not at the origin of the installation, the resistance of the distribution circuit must be taken into account. If the $R_1 + R_2$ of a distribution circuit is 0.2Ω and the Z_e is 0.1Ω , the Z_s at the DB would be 0.3Ω . So to work out the Z_s of the final circuit, the following would be applied:

$$Z_s = Z_s \text{ at DB} + R_1 + R_2$$

Once the $R_1 + R_2$ has been calculated, the Z_s can be determined by:

$$Z_s = Z_e + R_1 + R_2$$

So if the above example had a Z_e of 0.35Ω , the Z_s would be:

$$0.35 + 0.54 = 0.89 \Omega$$

Remember, the Z_s must be lower than the maximum values of Z_s from the tables in Chapter 41 of BS 7671 to ensure that the circuit would disconnect in the event of a fault, in the required disconnection time specified by BS 7671. These tables are:

- Table 41.2 for circuits protected by fuses where disconnection must be within 0.4 seconds
- Table 41.3 for circuits protected by circuit breakers or RCBOs for all disconnection times
- Table 41.1 for circuits protected by fuses where disconnection up to 5 seconds is permitted.

On many occasions, the csa of the cpc is governed by the size of the live conductors, especially if the cpc is incorporated in the cable. If a circuit is wired using single-core cable, then it is up to the designer to select a cpc csa. In most cases, especially for small power circuits, the designer is very likely to select a cpc which is the same csa as the live conductors.

On larger circuits, significant cost savings can be made by selecting a suitably sized cpc with a reduced csa. The problem with this is that you are working with a blank canvas and the Z_s cannot be determined and verified without many hit and miss calculations. It is therefore better to work backwards, in this situation, using the maximum permitted Z_s . This can be done by applying:

$$\text{maximum } R_1 + R_2 = \frac{Z_s \text{ max} - Z_e}{I_s \text{ factor} \times \text{length}} \times 1000 \text{ (in m}\Omega\text{/metre)}$$

From this calculation, a suitable cpc csa can be selected from Table I1 of the IET On-Site Guide by ensuring that a cpc is selected, along with the live conductor csa (which has already been set), by selecting a $\text{m}\Omega\text{/m}$ value from the table less than the value from the calculation.

Example: Determining size of cpc

Determine the size of cpc that would be acceptable where a circuit is to be wired using 70°C thermoplastic insulated 4 mm^2 live conductors in surface conduit, the maximum Z_s from Table 41.2 is 1.37Ω and Z_e is 0.24Ω . The circuit is 18 m in length and is protected by a 32 A Type B circuit breaker to **BS EN 60898**.

From Table I3, a factor for bunched 70°C thermoplastic cables is 1.2.

So as:

$$\text{maximum } R_1 + R_2 = \frac{Z_s \text{ max} - Z_e}{I_s \text{ factor} \times \text{length}} \times 1000 \text{ (in m}\Omega\text{/metre)}$$

Then:

$$\frac{1.37 - 0.24}{1.2 \times 18} \times 1000 = 52.31 \text{ m}\Omega/\text{metre}$$

So, looking at Table I1 in the On-Site Guide, any shown combination of cpc can be used as they all have a combined value far below this calculated value. If a 1.5 mm² cpc is selected, it would have a combined resistance of 16.71 mΩ/m. If this 1.5 mm² cpc is selected, the actual $R_1 + R_2$ would be:

$$\frac{16.71 \times 1.2 \times 18}{1000} = 0.36 \Omega$$

And the Z_s would be:

$$0.24 + 0.36 = 0.6 \Omega$$

This is below the maximum 1.37 Ω permitted and is therefore acceptable. But we knew it would be!

Chapter 54 of **BS 7671** requires the cpc for a circuit to be suitable for thermal constraints. This means that the cpc must be capable of carrying the fault current, for the duration of time it takes the protective device to disconnect, without the cable rising above its final limiting temperature (see Chapter 3 of this book). In simple terms, the protective device should disconnect before the cable insulation melts and the hot conductor becomes a high risk.

To determine the minimum cpc csa suitable for this, the adiabatic equation is used as detailed in Chapter 54:

$$S = \frac{\sqrt{I^2 t}}{k}$$

where:

- S is the minimum cpc csa in mm² suitable for thermal constraints
- I is the actual fault current based on the circuit Z_s
- k is a constant value found in Tables 54.2 to 54.5 in BS 7671.

INDUSTRY TIP

Finding k : which table to use

- Table 54.2 where the cpc is not bunched or incorporated into the cable. Examples include a single-core cpc tied to an SWA cable or where the sheath of a MICC cable is used.
- Table 54.3 where the cpc is bunched with live conductors or is incorporated into a cable. This is the most commonly used table for all composite cables where a core is used as a cpc or where cables are installed in trunking or conduit.
- Table 54.4 where the armour or sheath of a cable, such as an SWA, is used as the cpc, except MICC as there is no copper value in this table.
- Table 54.5 where the metallic part of a wiring system is used as a cpc, such as conduit or trunking.

Using the earlier example, Z_s was calculated as 0.6 Ω using a 1.5 mm² cpc bunched in conduit, and protection was by a 32 A Type B circuit breaker.

Looking at Table 54.2, for a bunched cpc, the value of $k = 115$.

The fault current, which is dictated by the Z_s , is found using simple Ohm's law:

$$I = \frac{V}{Z}$$

So:

$$\frac{230}{0.6} = 383 \text{ A}$$

The value of t can be found using the time/current graphs in Appendix 3 of BS 7671, or by consulting manufacturers' information. Using Appendix 3, the protective device in this example would disconnect within 0.1 seconds with a fault current of 383 A.

So applying the adiabatic equation to determine the minimum permissible csa:

$$\frac{\sqrt{383^2 \times 0.1}}{115} = 1.05 \text{ mm}^2$$

INDUSTRY TIP

Remember, the numbered points below refer to each column in the design grid. We covered columns 1–15 for live conductors above.

As the selected cpc is 1.5 mm^2 , this is suitable.

Completion of the design grid for protective conductors

We can now see how the process of sizing protective conductors can be applied to the design grid. The section for protective conductors starts at column 16.

Note, if the cpc csa is already given because the cpc is part of a cable and therefore a fixed csa, the calculation in column 19 is not required.

16 Insert the maximum permissible disconnection time from BS 7671 into column 16.

17 Insert the maximum value of Z_s permitted by BS 7671 into column 17. These can be found in BS 7671:

- Table 41.2 for circuits protected by fuses where disconnection must be within 0.4 seconds
- Table 41.3 for circuits protected by circuit breakers or RCBOs for all disconnection times
- Table 41.1 for circuits protected by fuses where disconnection up to 5 seconds is permitted.

18 Insert the appropriate factor from Table I3 in the IET On-Site Guide into column 18.

19 Where a cpc csa is not known, use the following formula to determine the minimum combination of line and cpc in $\text{m}\Omega/\text{m}$ using Table I1 of the IET On-Site Guide:

$$\text{maximum } R_1 + R_2 = \frac{Z_s \text{ max (col 17)} - Z_e}{I_3 \text{ factor (col 18)} \times \text{length (col 10)}} \times 1000 \text{ (in m}\Omega/\text{metre)}$$

Where the cpc csa is known, ignore this step and insert the csa into column 20.

INDUSTRY TIP

If calculating final circuits at a remote distribution board (DB), use the value of Z_s at DB (Z_{db}) instead of Z_e .

20 If the cpc csa is known because the cpc is a core in the cable, insert the csa in column 20. If the cpc is to be selected based on the calculation in column 19, select a line/cpc combination from Table I1 that has a value less than that calculated in column 19.

21 Calculate the actual $R_1 + R_2$ using:

$$\text{actual } R_1 + R_2 = \frac{\text{m}\Omega/\text{metre (table I1 OSG for selected cable)} \times \text{length (col 10)} \times I_3 \text{ factor (col 18)}}{1000}$$

Insert the calculated value of $R_1 + R_2$ into column 21.

22 Calculate the actual Z_s at operating temperatures using:

$$Z_s = Z_e + (R_1 + R_2 \text{ column 21})$$

Insert the calculated Z_s into column 22.

Once the Z_s has been calculated, we can compare the calculated value to tables in BS 7671:

- Table 41.2 for circuits protected by fuses where disconnection must be within 0.4 seconds
- Table 41.3 for circuits protected by circuit breakers or RCBOs for all disconnection times
- Table 41.1 for circuits protected by fuses where disconnection up to 5 seconds is permitted.

23 Now, based on the nominal voltage to earth (generally 230 V) and the calculated Z_s , the actual fault current can now be determined using:

$$I = \frac{U_0}{Z_s \text{ (column 22)}}$$

The fault current calculated can be inserted into column 23.

24 Using Appendix 3 of BS 7671, determine the actual disconnection time, based on the actual fault current and protective device, then insert this into column 24.

25 Determine the values of k from BS 7671 depending on how the cpc is to be arranged.

26 Finally, calculate the minimum permissible cpc size for thermal constraint using the adiabatic equation.

$$S = \frac{\sqrt{I(\text{col 23})^2 \times t(\text{col 24})}}{k(\text{col 25})} \text{ in mm}^2$$

Providing that the cpc size calculated and inserted into column 26 is smaller in csa than the one actually selected and recorded in column 20, the cpc selected will be suitable under fault conditions.

One of the key advantages of using the design grid method is seeing all the information together: an essential part of grid design is ensuring calculated values meet the requirements, and that simple format allows values to be compared easily.

INDUSTRY TIP

Remember, each numbered step (1–26) refers to each column in the design grid.



Worked example of the design grid: sizing live and protective conductors

We will now apply what we have learnt to the following example.

A circuit is to be designed to supply a 7.2 kW three-phase motor having a power factor of 0.7. The circuit is to be wired using single-core 70°C thermoplastic single-core, non-sheathed cable in surface steel conduit to a length of 28 m and it will be grouped with two other similar circuits.

The circuit is protected by a circuit breaker to **BS EN 60898**. Ambient temperature is 30°C and Z_e at the origin of the installation and circuit is 0.12 Ω.

▼ Table 5.16 Circuit details in table format

Circuit	Load	Protective device	Length	Wired using	Ambient temperature	Grouping	Thermal insulation	cpc type	Z_e
1	7.2 kW three-phase motor with a power factor of 0.7	BS EN 60898	28 m	Single-core 70°C thermoplastic cable in surface steel conduit	30°C	2 other similar circuits	None	Single-core cable	0.12 Ω

- 1 Insert 7200 W into column 1.
- 2 Determine design current:

$$I_b = \frac{\text{watts (col 1)}}{\sqrt{3} \times 400 \times \text{pf}}$$

So:

$$\frac{7200 \text{ (col 1)}}{\sqrt{3} \times 400 \times 0.7} = 14.8 \text{ A per line}$$

Insert 14.8 into column 2.

- 3 Select I_n where $I_n \geq I_b$ so $I_n = 16$ A and, as it is a motor, a Type C circuit breaker is suitable.
- 4 Select reference method – B from Table 4A2 – and insert into column 4.
- 5 Insert 30°C into column 5 as this is the stated ambient temperature.
- 6 Insert a code that reflects the type of cable into column 6, such as 70°C PVC singles.
- 7 Select the appropriate rating factor (C_a) for the ambient temperature shown in column 5. As the temperature is 30°C, from Table 4B1 in BS 7671, the value is 1. Remember, 1 can be ignored or insert 1 into column 7.
- 8 Select a suitable rating factor for grouping (C_g) from Table 4C of BS 7671. Based on the conduit containing three circuits in total as reference method B, $C_g = 0.7$ which is inserted into column 8.
- 9 As there are no other rating factors to consider, column 9 can be left blank.
- 10 Insert the given circuit length into column 10, which is 28 m.
- 11 Insert the maximum allowed voltage drop. As this is a power circuit, this is allowed to be 5% of the supply voltage. As this is a three-phase supply, 5% of 400 V is 20 V. Based on the information gained so far, the grid should look like this:

ACTIVITY

Remind yourself as to why there are different types of circuit breakers and the reasons for selection. This was covered in Chapter 3 of this book, pages 191–5 and Chapter 3 of Book 1, pages 206–9.

Circuit number	1	2	3	4	5	6	7	8	9	10	11	12	13	14	15
Watts	7200	14.8	16 Type C	B	30	PVC singles 4D1	1	0.7	-	28	20				
I_b design current	stated	Calc 1 or known	select	Table 4A2	stated	stated	Table 4B	Table 4C or $\frac{1}{\sqrt{n}}$	stated	stated	stated	Calc 2	Table 4D-	Table 4D--	Calc 3
I_n device rating															
Method of installation															
Ambient temp in °C															
Cable type/insulation															
Ca ambient temp. factor															
Cg grouping factor															
C other factors that may be applicable															
Length in metres															
Max. Volt. Drop															
mV/A/m max.															
Size selected mm ² based on col 12 as suitable for voltage drop															
I_t /csa															
I_z (must be larger than I_n)															

▲ Figure 5.13b Design grid – up to completion of step 11

- 12 Determine the maximum voltage drop in mV/A/m to select a suitable minimum csa of conductor for voltage drop:

$$\max \text{ mV/A/m} = \frac{\text{max voltage drop (col 11)} \times 1000}{I_b \text{ (col 2)} \times \text{length (col 10)}}$$

As the maximum voltage drop is 20 V as it is a three-phase 400 V circuit (5% of 400 V):

$$\max \text{ mV/A/m} = \frac{20 \text{ (col 11)} \times 1000}{14.8 \text{ (col 2)} \times 28 \text{ (col 10)}} = 48.26 \text{ mV/A/m}$$

- 13 To select a suitable csa of live conductors for voltage drop, look at Table 4D1B and select a value less than 48.26 from column 6 as it is a three-phase circuit and method B.

Looking at the table, a 1 mm² conductor or larger will be suitable for voltage drop and this can be recorded in column 13. This proves that any conductor which is finally selected for current-carrying capacity, providing it is equal to or larger than 1 mm², will be suitable for voltage drop.

- 14 **However:**

Looking at the current capacities, from Table 4D1A: column 5, a 1 mm² conductor is only capable for 12 A. We know this is not suitable as the protective device is 16 A. Looking further down Table 4D1A, a 2.5 mm² conductor has an I_t value of 21 A, which is greater than 16 A, but to prove suitability we must ensure the I_z is greater than I_n :

$$I_z = I_t \text{ (col 14)} \times C_a \text{ (col 7)} \times C_g \text{ (col 8)} \times C_i \text{ (col 9)}$$

So the only applicable factor is C_g

$$I_z = 21 \times 0.7 \text{ (col 8)} = 14.7 \text{ A}$$

14.7 is less than 16 A; this is **not** acceptable so choose a **4 mm²** conductor which has an $I_t = 28 \text{ A}$

So:

$$I_z = 28 \times 0.7 \text{ (col 8)} = 19.6 \text{ A}$$

19.6 A is larger than 16 A so this is acceptable for current-carrying capacity.

15 In column 13, a 4 mm² conductor can be inserted and in column 14, the tabulated value for the cable which is 28 A. The calculated I_z of 19.6 can be inserted in column 15.

To make some comparisons at this point, as we know a 1 mm² conductor is suitable for voltage drop, a 4 mm² conductor certainly is and we have proven it for current capacity as I_z is greater than I_n .

1	7200	14.85	16 Type C	B	30	PVC singles 4D1	1	0.7	-	28	20	48.26	4	28	19.6
	stated	Calc 1 or known	select	Table 4A2	stated	stated	Table 4B	Table 4C or $\frac{1}{I_z}$	stated	stated	stated	Calc 2	Table 4D-	Table 4D--	Calc 3
	Watts	I_b design current	I_n device rating	Method of installation	Ambient temp in °C	Cable type/insulation	Ca ambient temp. factor	Cg grouping factor	C other factors that may be applicable	Length in metres	Max. Volt. Drop	mV/A/m max.	Size selected mm ² based on col 12 as suitable for voltage drop	It/csa	I_z (must be larger than I_n , or, ring: greater than 20 A)
1															

▲ Figure 5.13c Design grid – up to completion of step 15

16 Insert the maximum permissible disconnection time into column 16. The maximum disconnection time for this circuit is 0.4 seconds as it is a final circuit, supplying an item of fixed equipment rated below 32 A.

17 To get the cpc size correct to the Z_s , we need to determine the maximum permissible Z_s .

For this we look at Tables 41.2–4 (Chapter 41) depending on the protective device and disconnection time:

- Table 41.2 – Fuses 0.4 seconds
- Table 41.3 – Circuit breakers/RCBOs whatever the disconnection time (instantaneous)
- Table 41.4 – Fuses 5 second disconnection.

So for a 16 A Type C device, the value of $Z_s = 1.37 \Omega$

18 Using Table I3, the operating temperature factor for a 70°C thermoplastic cable bunched is 1.2 and this can be inserted into column 18.

19 Using the values obtained so far, calculate the maximum $R_1 + R_2$ in mΩ/m:

$$\text{maximum } R_1 + R_2 = \frac{Z_s \text{ max (col 17)} - Z_e}{I_3 \text{ factor (col 18)} \times \text{length (col 10)}} \times 1000 \text{ (in m}\Omega\text{/metre)}$$

$$\text{maximum } R_1 + R_2 = \frac{1.37 \text{ (col 17)} - 0.12}{1.2 \text{ (col 18)} \times 28 \text{ (col 10)}} \times 1000 = 37.2 \text{ m}\Omega\text{/m}$$

20 Looking at Table I1 of the IET On-Site Guide, and remembering we have 4 mm² line conductors, we need to select a line cpc combination having resistance value less than 37.2 and make a judgment on the size we want to select, so:

▼ Table 5.17 Section replicating some of the values shown in Table I3 in the IET On-Site Guide

Line	cpc	mΩ/m
4	1.5	16.71
4	2.5	12.02
4	4	9.22

As all the values are less than 37.2 mΩ/m, we can select a 1.5 mm² cpc which has a combination resistance of 16.71 mΩ/m at 20°C.

0.4	1.37	1.2	37.2	1.5						
Table 41.1	Table 41—	OSG	Calc 4	OSG Calc 5 or stated	Calc 6	Calc 7	Calc 8	App 3	Table 54.2	Calc 9
Max Disc. time	Max. Z _s	OSG Table I3 factor	Max. R ₁ +R ₂ in mΩ/metre	CPC size (from OSG Table I1 or as given by cable size)	Actual R ₁ +R ₂	Actual Z _s	Actual fault current (at 230 V)	Actual Disc. Time	k values	Thermal constraint minimum csa
16	17	18	19	20	21	22	23	24	25	26

▲ Figure 5.13d Design grid – up to completion of step 20

21 To calculate the actual R₁ + R₂ the following formula is used:

$$\text{actual } R_1 + R_2 = \frac{\text{m}\Omega/\text{metre (Table I1)} \times \text{length (col 10)} \times I_3 \text{ factor (col 18)}}{1000}$$

where:

$$\text{actual } R_1 + R_2 = \frac{16.71 \text{ (Table I1)} \times 28 \text{ (col 10)} \times 1.2 \text{ (col 18)}}{1000} = 0.56 \Omega$$

The calculated value of 0.56 Ω can now be inserted into column 21.

22 Z_s can now be determined by calculating:

$$Z_s = Z_e + R_1 + R_2 \text{ (col 21)}$$

So:

$$0.12 + 0.56 = 0.68 \Omega$$

The value of Z_s calculated as 0.68 Ω can now be inserted into column 22. To verify correct design, compare to the maximum permitted (column 17) and as 0.68 Ω is less than the permitted 1.37 Ω, this is acceptable.

	0.4	2.73	1.2	77.67	1.5	0.56	0.68				
	Table 41.1	Table 41—	OSG	Calc 4	OSG Calc 5 or stated	Calc 6	Calc 7				
	Max. Disc. time										
	Max. Z_s										
	OSG Table I3 factor										
	Max R_1+R_2 in mΩ/metre										
	CPC size (from OSG Table I1 or as given by cable size)										
	Actual R_1+R_2										
	Actual Z_s										
	Actual fault current (at 230 V)										
	Actual Disc. Time										
	k values										
	Thermal constraint minimum c_{sa}										
16											
17											
18											
19											
20											
21											
22											
23											
24											
25											
26											

▲ Figure 5.13e Design grid – up to completion of step 22

23 Knowing the Z_s value, this can be used to calculate the fault current to earth:

$$\frac{U_0}{Z_s \text{ (col 22)}} = \text{fault current to earth}$$

so:

$$\frac{230}{0.68} = 338 \text{ A}$$

24 Determine the actual disconnection time from Appendix 3 of BS 7671 based on the value of fault current shown in column 23.

As the protective device is a 20 A Type C circuit breaker to **BS EN 60898**, Table 3A5 is the particular graph needed. In this example, the actual fault current of 338 A exceeds the value of current shown in the table which causes the circuit breaker to disconnect instantaneously (0.1 seconds) which is shown as 200 A. As a result, 0.1 s can be inserted into column 24.

25 To calculate the adiabatic equation, we need to determine the value of k for the type of cable used and how it is installed. As Table 54.2 is for cables which are bunched and referencing 70°C thermoplastic cable, the value of k that can be recorded in column 25 is 115.

26 Now we have the required information, the adiabatic equation can be calculated to determine the minimum suitable cpc for thermal constraints.

$$\frac{\sqrt{I \text{ (col 23)}^2 \times t \text{ (col 24)}}}{k \text{ (col 25)}}$$

Putting this information into the calculation, remember:

- from column 25: $k = 115$
- from Appendix 3, a fault current of 338 A (column 23) would disconnect the 16 A Type C device in < 0.1 seconds (column 24).

INDUSTRY TIP

Putting in the time to complete an accurate grid will pay dividends later. By using the grid, we can easily see all our data for the circuit and, should anything change, such as cable length, we can easily make the changes and check them.

So, to calculate the minimum csa suitable, apply:

$$\frac{\sqrt{338 \text{ (col 23)}^2 \times 0.1 \text{ (col 24)}}}{115 \text{ (col 25)}} = 0.93 \text{ mm}^2$$

As the calculated minimum suitable cpc is 0.93 mm² and we have selected a 1.5 mm² cpc, this is suitable as 1.5 mm² is larger than the calculated 0.93 mm².

0.4	2.73	1.2	77.67	1.5	0.56	0.68	338	<0.1	115	0.93
Table 41.1	Table 41—	OSG	Calc 4	OSG Calc 5 or stated	Calc 6	Calc 7	Calc 8	App 3	Table 54.2	Calc 9
Max. Disc. time	Max. Z _s	OSG Table I3 factor	Max R ₁ +R ₂ in mΩ/metre	CPC size (from OSG Table I1 or as given by cable size)	Actual R ₁ +R ₂	Actual Z _s	Actual fault current (at 230 V)	Actual Disc. Time	k values	Thermal constraint minimum csa
16	17	18	19	20	21	22	23	24	25	26

▲ Figure 5.13f The completed grid for protective conductors

IMPROVE YOUR MATHS



Make use of your computer to ensure you keep your data safe and accurate. You can transfer the grid into a spreadsheet, input formulas into some of the cells, and the spreadsheet does the calculations for you.

KEY POINT



When undertaking the grid method, here are some final points to consider.

- If the calculated Z_s is larger than the permitted Z_s for the circuit from Tables 41.2, 41.3 or 41.4, but the device is an RCBO and the Z_s is within values permitted in Table 41.5, always check that the circuit has adequate short circuit protection using the adiabatic equation from Chapter 43 of BS 7671 (return to Chapter 3 of this book).
- Always check suitability of a value before moving onto the next step.
- As mentioned at the start of this section relating to the design grid, if you are researching values in BS 7671 for one circuit from a particular table, find the values for all the circuits while on that table. This makes designing multiple circuits much more efficient.

Overload situations

We discussed correct current coordination as we looked at the design process. As a reminder; for a circuit to comply with the requirements of Chapter 43, it must be correctly coordinated. This means that the protective device rating is suitable for the design current and the cable has a current capacity that is suitable for the protective device.

In short:

$$I_b \leq I_n \leq I_z$$

Where:

- I_b is the circuit design current
- I_n is the rating of protective device
- I_z is the current-carrying capacity of the conductor based on installed conditions.

If, on a rare occasion, a circuit may be reasonably subjected to overloads, Section 4 of Appendix 4 states:

$$I_z \geq 1.45 \times I_n$$

So in a normal circuit where overloads are not expected, as long as the circuit was coordinated, such as in the following example, the circuit is suitable.

Example



If we had a circuit that had a design current of 14 A, was protected by a 16 A device and the circuit cable had a current-carrying capacity, after consideration of the installed conditions, of 24 A, then this could be expressed as:

$$I_b = 14 \text{ A} < I_n = 16 \text{ A} < I_z = 24 \text{ A}$$

But if that circuit was liable to overloads then:

$$16 \times 1.45 = 23.2 \text{ A} < 24 \text{ A } I_z$$

So, in this situation, the circuit would also have capabilities for any potential short-term overloads.

The reason for the 1.45 factor is that most protective devices would not reasonably disconnect at a current less than this. A quick look at Appendix 3 shows that a 16 A Type B circuit breaker would not disconnect until approximately 23 A is reached. Even then, it would take 10 000 seconds, which is approximately 2 hours 45 minutes.

So as long as the cable is capable of this current, it will not severely overheat.

Overload is not something that should be of concern in most circuits, providing the design procedure has been followed. There are, however, certain circumstances where a designer may compensate for overload.

Imagine a hotel conference room where socket outlets may only normally supply power to laptops and mobile phone chargers. If, however, the heating broke, the hotel may bring in some temporary heaters. This may overload the circuit, so an experienced designer would ensure the cable selected would have an I_z value at least $1.45 \times I_n$.

MAXIMUM DEMAND AND DIVERSITY

The need to determine the **maximum demand** and include the application of **diversity** is essential when requesting a new supply from a distribution network

KEY TERMS

Maximum demand: The total consumption of an installation assuming everything is being used at the same time.

Diversity: The assessment of the total electrical equipment or loading in use at any one time within an installation. The designer will make this reasonable judgement based on knowledge of the expected operation of the installation.

operator (DNO). In order for them to provide an adequate supply for any new installation, they will need to review these figures.

As it is unrealistic for all equipment to be used at the same time, diversity is applied. Diversity is a careful assessment of what, within an installation, would be used at any one time, including the durations of use, to determine the actual consumption needs. This assessment would be influenced by the type of premises. These might be, for example

- domestic dwellings
- small shops and offices
- hotels
- large commercial buildings
- industrial facilities.

As an example, a hotel could have 60 rooms all containing a 16 A radial circuit supplying socket outlets. The assumed maximum demand of these circuits alone would be:

$$16 \times 60 = 960 \text{ A}$$

Obviously, these circuits will never be used at full load all of the time, so diversity is applied. Even though each room contains a TV, kettle and may have a laptop plugged in, the total loading at any one time is very unlikely to exceed 100 A. These assessments of actual demand are an example of diversity.

As well as making an assessment for maximum demand and diversity for a new supply, other reasons may include:

- installation of electric vehicle charging points
- tariff assessments where green technology is installed, such as PV arrays
- requiring a standby generator for when planned power outages occur
- assessing the impact of additions to an existing electrical installation
- fulfilling the requirements of Section 311 of **BS 7671** when designing installation work.

Maximum demand

Calculating the maximum demand for an installation is a relatively simple process; it is the sum of all the design currents of the individual final circuits per phase.

▼ Table 5.18 Example of maximum demand

Circuit no.	Type	Design current
1	Cooker	27.3 A
2	Water heater	13.1 A
3	Ring-final circuit socket outlets	32 A
4	Ring-final circuit socket outlets	32 A
5	Lighting	4.7 A
6	Lighting	3.8 A
	Total	112.9

INDUSTRY TIP

Chapter 2 of this book, pages 98–9, introduced and explained kVA and kW and the relationship between them. Always remember that kW is not the same as kVA, so if power factor is not properly considered, a system could be seriously overloaded if kVA is assumed the same as kW.

The maximum demand could also be expressed as kilo-volt-amperes by multiplying the volts and amperes and dividing the value by 1000 so:

$$\text{kVA} = \frac{V \times A}{1000}$$

Therefore for this installation:

$$\text{kVA} = \frac{230 \times 112.9}{1000} = 25.97 \text{ kVA}$$

IMPROVE YOUR MATHS



Three different single-phase, 230 V circuits are to be designed to supply three machines having the following characteristics:

- 3 kW $\cos \theta = 0.7$
- 2.2 kW $\cos \theta = 0.6$
- 1.6 kW $\cos \theta = 0.68$

Determine the:

- a kVA for each load
- b design current for each load
- c kW when all the loads are running together
- d kVA when all the loads are running together.

Diversity

There are three methods of applying diversity to the maximum demand:

- Table A2 in the IET On-Site Guide
- factoring individual final circuit
- factoring the entire installation.

INDUSTRY TIP

Remember, diversity is not applied to final circuits when calculating the csa of the circuit cable, except for those circuits listed in Table A1 of the IET On-Site Guide, such as cooker circuits.

Table A2 method of applying diversity

Table A2 in the IET On-Site Guide provides guidance on the application of diversity to an installation. The application depends on the type of circuit and the type of building use.

Based on a domestic property, the results are shown in Table 5.19.

▼ Table 5.19 Application of diversity using the On-Site Guide Table A2 method

Circuit no.	Type	Design current	Diversity as Table A2	Demand after diversity
1	Cooker	27.3 A	Already applied	27.3 A
2	Water heater	13.1 A	No diversity allowed	13.1 A
3	Ring-final circuit socket outlets	32 A	100%	32 A
4	Ring-final circuit socket outlets	32 A	40%	12.8 A
5	Lighting	4.7 A	66%	3.1 A
6	Lighting	3.8 A	66%	2.5 A
	Total	112.9		90.8 A

Factoring circuits method of applying diversity

With experience and the necessary information, a designer can make an assessment of the likely loading of a circuit.

As an example, a 32 A ring-final circuit could be installed for the 1st floor of a dwelling with three bedrooms. At any one period, the likely demand on that circuit could be a TV, clock radios and some table lamps, so realistically, the demand would be no more than 6 or 7 A. Periodically, and for relatively short durations, a hairdryer may be used, taking demand to 16 A but for a very short time. As a result, the circuit is only demanding 22% of the design current, which equates to a factor of 0.22.

Similarly, a socket-outlet circuit within a large open space, such as a restaurant, has many socket outlets but only for convenience of location and most are hardly used at any one time. In this situation, a factor of 0.1 could be applied to that circuit, meaning only 10% of the full load would be expected.

▼ Table 5.20 Application of diversity using the factoring method

Circuit no.	Type	Design current	Diversity factor	Demand after diversity
1	Cooker	27.3 A	1	27.3 A
2	Water heater	13.1 A	1	13.1 A
3	Ring-final circuit socket outlets	32 A	0.3	9.6 A
4	Ring-final circuit socket outlets	32 A	0.2	6.4 A
5	Lighting	4.7 A	0.6	2.8 A
6	Lighting	3.8 A	0.5	1.9 A
	Total	112.9		61.1 A

Factoring installations method of applying diversity

Many installations follow patterns of consumption, and as a result, DNOs and designers apply factors to the maximum demand based on the type and use of an installation. Some examples are shown below in Table 5.21.

▼ Table 5.21 Examples of factors applied to entire installations

Type of installation	Factor	Remarks
Dwellings	0.4	Without electric heating as the main form of heating
Hotels	0.6	Increases may be made depending on facilities within the hotel, such as restaurant size, function rooms, etc.
Shops	0.6	Department stores may be higher
Schools	0.7	
Assembly rooms, restaurants, theatres, etc.	0.6	

Using the previous example of the domestic dwelling, the calculation for factoring installation would now be:

$$112.9 \times 0.4 = 45.16 \text{ A}$$

Although a DNO would normally provide a 63 A or 80 A supply, they would use this figure when assessing the demand on the substation transformer.

INDUSTRY TIP

A detailed list of the factors applicable to entire installations can be found in Table 3.3 of the IET Electrical Installation Design Guide (2nd Edition).

Designers may use the above factor when designing distribution circuits in blocks of flats.

Load control for domestic installations

One of the problems when considering maximum demand in new housing is the added burden on the supply where electric vehicle charging is installed. On average, a vehicle charger may be rated at 7 kW which equates to 30 A being consumed during the initial part of the charging cycle. If this were to happen at the same time as an 8 kW electric shower (35 A) and a 7.6 kW induction hob (33 A) the supply would not cope.

There are two possible solutions to this.

- Supplementing the supply with photovoltaic (PV) solar panels and/or micro-wind turbines. At times of less demand, these can also store the energy generated into a battery storage system.
- Using smart metering in conjunction with load switching or smart charging devices to stop vehicle charging during times of high consumption. Alternatively, a charged vehicle can act as a storage system and provide electricity for the installation at times of peak demand.

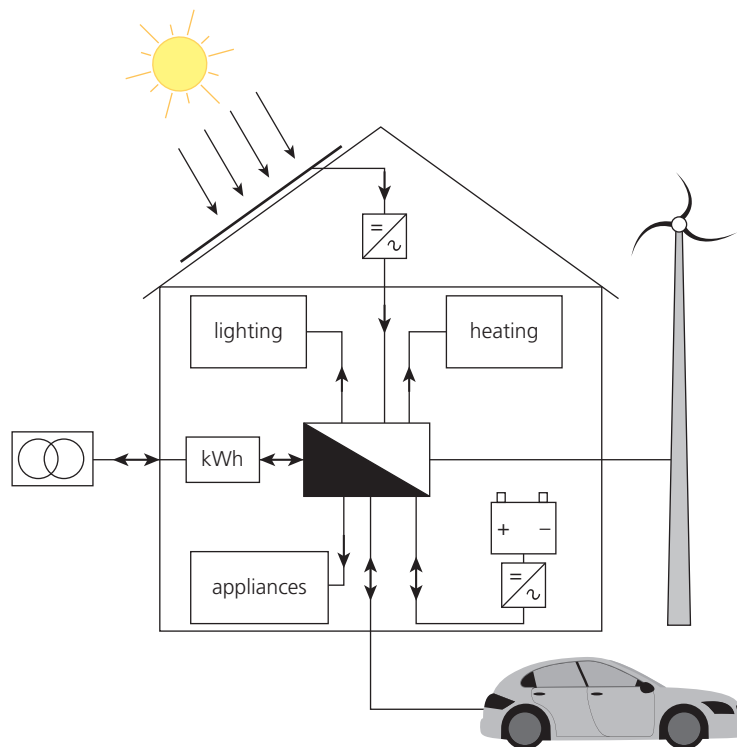

▲ Figure 5.14 A prosumer's installation which can consume energy from the public supply network as well as from its own generator or electricity storage systems

Accessibility aids in domestic installations

In the UK, more and more people are living longer, independent lives in their own homes. Add to this the growing number of people (of all ages) with limited mobility also living more independent lives, the need for accessibility aids in the home increases.

Approved Document M of the building regulations (England) does not give any requirements for accessibility aids in dwellings so the needs must be defined by the client and product manufacturer.

Accessibility aids in dwellings that involve electrical work can include these features.

- Stair lifts: these are chair lift systems that run on a rail fitted to the side of staircases. These are one of the most common forms of mobility aids in private dwellings giving less able people the ability to move between floors using a cost effective option.



▲ Figure 5.15 A chair-type stairlift

- 'Between floor' lifts: these are lift systems that pass through the floor to take people between floors within a house. They can be built into a house as a separate shaft but are more commonly retrofitted to existing houses. They could be installed internally by cutting through the floor and installing an (often transparent) shaft for the lift system. These lifts can also be installed externally to the side of a building where openings need to be cut into the side of a building to provide access to the internal floors. As these lifts are quite slow speed and intended for one person at a time, possibly in a wheelchair, power consumption is small and so can be added to an existing supply.
- Platform lifts: platform lifts are open lift systems and lift people between floors or levels in an open space such as a hallway. As these are open, the height they are used for is usually limited so the risk of a person dropping an object onto others is reduced.



▲ Figure 5.16 Building entrance equipped with special lifting platform for wheelchair users

- Overhead hoist systems: these are powered lifting hoists that can transport a person from one place to another on an overhead rail system. Most commonly, the lifting mechanism is electrically powered, but moving the hoist along the rails is generally not powered and relies on another person pushing the person in the hoist along. Overhead hoist systems are commonly used to lift a person from a mobility chair to a bed or into a bathroom or toilet area.
- Height-adjustable worktops or equipment: these can be electrically powered worktops, such as kitchen worktops, that can be lowered to suit the height of a person in a wheelchair and then raised to a suitable height for people standing. These are not limited to kitchen worktops but can include home office desks or medical stations.
- Home medical systems: these are specialist medical systems tailored to an individual's requirements. For example, people who have kidneys that do not work properly need regular machine dialysis to remove toxins from their blood several times a week. Some opt to have dialysis machines at home rather than visit a hospital each time. Considerations for this machine may include the need for an uninterruptible power supply (UPS) in case of a power failure. In addition, the room may need specific heat and ventilation requirements to keep humidity to a minimum.

INDUSTRY TIP

Remember, if equipment is to have no RCD protection, the circuit must not be concealed in a wall (Regulations group 522.6) and have no socket outlets (Regulation 411.3.3) to comply with BS 7671.

Whilst most of the above systems will probably be installed by other trades or specialists, sometimes they may require particular conditions for the electrical supply. This could be the need to remove RCD protection to eliminate the risk of becoming stranded in lifts due to nuisance tripping, or the need for UPS systems to back up the electrical supply.

Test your knowledge

- 1 Which chapter in BS 7671 gives the fundamental principles of design?
 - a 11
 - b 13
 - c 41
 - d 52
- 2 What is the maximum value of Z_e that a distribution network operator will declare for a TN-C-S system?
 - a 0.1Ω
 - b 0.35Ω
 - c 0.8Ω
 - d 21Ω
- 3 What essential information will a distribution network operator need on an application for a new supply?
 - a Building height.
 - b Tender sum.
 - c Location plan.
 - d Expected Z_s values.
- 4 A distribution circuit on a 230 V installation has a voltage drop of 3 V. What voltage drop is allowed for lighting circuits supplied from it?
 - a 3.6 V
 - b 6.9 V
 - c 8.5 V
 - d 11.5 V
- 5 What factor has the most impact on the selection of conduit which is to be concealed in a wall?
 - a Aesthetics.
 - b Accessibility.
 - c Electrical separation.
 - d External influences.
- 6 What type of circuit breaker is the most suitable for high inductive equipment?
 - a Type A.
 - b Type B.
 - c Type C.
 - d Type D.
- 7 What does selectivity ensure in the event of a fault?
 - a A protective device nearest the fault disconnects first.
 - b A protective device nearest the origin disconnects first.
 - c Equipment that is selected cannot have faults.
 - d Equipment of Class II is used in these situations.

- 8** A particular cable is 24 m long and has a tabulated value of 11 mV/A/m. What is the voltage drop when $I_b = 14$ A and $I_n = 20$ A?
- 3.7 V
 - 5.3 V
 - 6.9 V
 - 11.5 V
- 9** What is the rating factor for a 70°C thermoplastic cable installed in an ambient air temperature of 25°C?
- 0.70
 - 1.00
 - 1.03
 - 1.20
- 10** What is the design current for a 230 V, 16 kW cooker (without socket outlets) using the application of diversity?
- 16.4 A
 - 27.9 A
 - 45.1 A
 - 69.5 A
- 11** A single circuit is to be installed using 70°C thermoplastic single-core copper cable in surface-mounted conduit. The circuit is 28 m long and is to supply a 7.2 kW 230 V water heater. The ambient temperature is 35°C and the conduit contains one other circuit. Z_e has been recorded as 0.17 Ω at the origin of the circuit. The supply and installation is for a TN-S system. Determine:
- Design current.
 - Rating of protective device.
 - Method of installation.
 - Rating factor values for:
 - C_a
 - C_g
 - Minimum cross-sectional area of live conductors for current capacity and voltage drop.
 - $R_1 + R_2$, assuming the circuit protective conductor to be the same cross-sectional area as the line.
 - Z_s
- 12** What are the single-core cables connecting an installation energy meter called?
- Strappers.
 - Legs.
 - Heads.
 - Tails.

- 13** What name is given to a type of circuit that feeds a single item of equipment using one line and one neutral conductor?
- a** Ring-final.
 - b** Radial-final.
 - c** Direct-return.
 - d** Non-return.
- 14** Which is an example of a distribution circuit within a consumer's installation?
- a** A single-phase circuit supplying a 10-way DB.
 - b** A three-phase circuit supplying a transformer.
 - c** A single-phase circuit supplying a water heater.
 - d** A three-phase circuit supplying a warehouse hoist.
- 15** Which is a safe and recommended method of ensuring that a fault in one part of an installation will minimise inconvenience to other parts?
- a** Removing all protective devices.
 - b** Increasing the csa of all conductors.
 - c** Dividing an installation into circuits.
 - d** Install all circuits as ring-final.
- 16** Which appendix in BS 7671 gives time/current characteristics for protective devices?
- a** Appendix 1
 - b** Appendix 2
 - c** Appendix 3
 - d** Appendix 4
- 17** What is the percentage of full load current below which a conductor can be ignored for grouping?
- a** 5%
 - b** 15%
 - c** 30%
 - d** 50%
- 18** Which reference method of installation is given to a surface mounted conduit?
- a** A
 - b** B
 - c** C
 - d** F

- 19** What is determined when all rating factors are applied to a cable's given value of I_t as multipliers?
- a** I_z
 - b** I_b
 - c** I_a
 - d** I_n
- 20** Describe the difference between ways and modules when selecting a distribution board for an installation.
- 21** A 70°C thermoplastic cable is to be installed in an ambient air temperature of 45°C. Determine the rating factor for this and explain what the factor means.
- 22** A circuit is wired using 4/1.5 mm² twin and cpc flat profile PVC/PVC cable to a length of 32 m.
Determine the $R_1 + R_2$ of this circuit under load conditions.
- 23** Describe the importance of having a low earth fault loop impedance.

Practical task

Identify a circuit in your home or college. Assess what it supplies and how it is installed, then consider how you would design it. Do you agree with the original design?

INSPECTION, TESTING AND COMMISSIONING ELECTRICAL INSTALLATIONS

INTRODUCTION

Inspection, testing, commissioning and certification are very important stages of the safety process. Electricity can be very dangerous if the guidelines in **BS 7671: 2018 (2022)** The IET Wiring Regulations, 18th Edition are not followed. Refer back to Chapter 3 of this book.

Electrical inspection and testing can involve some degree of risk but if the guidelines are followed, the risk can be minimised. Every year, the Health and Safety Executive (HSE) investigates many cases of injury due to bad practice and poor workmanship; electric shock, burns and fatalities can happen. Many electricians do not mean to make mistakes but they can happen, and on busy sites, other trades can damage electrical parts without realising, leaving dangerous situations. Many of these incidents can be corrected through good inspection and testing following the installation work.

HOW THIS CHAPTER IS ORGANISED

This unit covers the health and safety requirements and includes the theory and testing skills required to become competent during the process of inspection, testing and commissioning of electrical installations.

Table 6.1 summarises the topics covered in this chapter.

T Level mapping grids are available on the Hodder Education website.

▼ Table 6.1 Chapter 6 assessment criteria coverage

Section	2365 Unit 304: Electrical Installations: Inspection, Testing and Commissioning	5357 Unit 112/012: Understand Inspection, Testing and Commissioning	8202 Unit 304: Principles of Inspection, Testing and Commissioning Electrical Systems	5393 Unit 112/012: Understand Inspection, Testing and Commissioning
Preparing for inspection and testing <ul style="list-style-type: none"> ● Regulatory requirements ● Safe isolation ● Purpose of inspection and testing ● Information required ● Documentation 	1.2; 1.3; 1.4; 1.5; 1.6 2.1; 2.2; 2.3; 2.4	1.2; 1.3; 1.4; 1.5; 1.6 2.1; 2.2; 2.3; 2.4	1.1; 1.2; 1.3; 1.4 4.1; 4.2	1.2; 1.3; 1.4; 1.5; 1.6; 1.7; 1.8 2.1; 2.2; 2.3; 2.4
The inspection processes <ul style="list-style-type: none"> ● Senses used ● The inspection schedule ● Inspection process 	3.1; 3.2; 3.3; 3.4; 3.5	3.1; 3.2; 3.3; 3.4; 3.5	1.5; 1.6; 1.7	3.1; 3.2; 3.3; 3.4
Testing <ul style="list-style-type: none"> ● The test sequence ● Test instruments ● The tests ● Completed documentation 	4.1; 4.2; 4.3; 4.4; 4.5; 4.6 5.1; 5.2; 5.3; 5.4; 5.5; 5.6; 5.7 6.1; 6.2; 6.3; 6.4; 6.5; 6.6; 6.7; 6.8; 6.9; 6.10; 6.11; 6.12; 6.13 7.1; 7.2; 7.3; 7.4; 7.5	4.1; 4.2; 4.3; 4.4; 4.5; 4.6 5.1; 5.2; 5.3; 5.4; 5.5; 5.6; 5.7 6.1; 6.2; 6.3; 6.4; 6.5; 6.6; 6.7; 6.8; 6.9; 6.10; 6.11; 6.12; 6.13 7.1; 7.2; 7.3; 7.4; 7.5	2.1; 2.2; 2.3; 2.4; 2.5; 2.6 3.1; 3.2; 3.3; 3.4; 3.5; 3.6 4.2	4.1; 4.2; 4.3; 4.4; 4.5; 4.6 5.1; 5.2; 5.3; 5.4; 5.5; 5.6; 5.7 6.1; 6.2; 6.3; 6.4; 6.5; 6.6; 6.7; 6.8; 6.9; 6.10; 6.11 7.1; 7.2; 7.3; 7.4; 7.5

PREPARING FOR INSPECTION AND TESTING

Inspection and testing can be a high-risk activity, not just for the inspector, but for anyone using or around the electrical installation being tested.

In order to safely inspect and test, inspectors need to know and understand the regulatory requirements as well as having a good understanding of the installation being inspected. Information relating to the installation is essential in order to carry out effective inspections and tests. In this section we will consider all the safety aspects of inspection and testing as well as the information needed.

Electricity at Work Regulations

You are expected to know the Electricity at Work Regulations 1989 (EAWR) and to understand how these impose responsibilities on the **duty holder** (you) when inspecting, testing, commissioning and certifying a new circuit or installation. Some important extracts from the EAWR 1989 are listed below.

KEY TERM

Duty holder: The person in control of the danger. This person must be competent by formal training and experience and with sufficient knowledge to avoid danger. The level of competence will differ for different items of work.

PART II GENERAL – Electricity at Work Regulations 1989

Regulation 4 – Systems, work activities and protective equipment

(1) All systems shall at all times be of such construction as to prevent, so far as is reasonably practicable, danger.

Regulation 13 – Precautions for work on equipment made dead

Adequate precautions shall be taken to prevent electrical equipment, which has been made dead in order to prevent danger while work is carried out on or near that equipment, from becoming electrically charged during that work if danger may thereby arise.

Regulation 14 – Work on or near live conductors

No person shall be engaged in any work activity on or so near any live conductor (other than one suitably covered with insulating material so as to prevent danger) that danger may arise unless –

- (a) it is unreasonable in all the circumstances for it to be dead; and
- (b) it is reasonable in all the circumstances for him to be at work on or near it while it is live; and
- (c) suitable precautions (including where necessary the provision of suitable protective equipment) are taken to prevent injury.

Regulation 15 – Working space, access and lighting

For the purposes of enabling injury to be prevented, adequate working space, adequate means of access, and adequate lighting shall be provided at all electrical equipment on which or near which work is being done in circumstances which may give rise to danger.

Regulation 16 – Persons to be competent to prevent danger and injury

No person shall be engaged in any work activity where technical knowledge or experience is necessary to prevent danger or, where appropriate, injury, unless he possesses such knowledge or experience, or is under such degree of supervision as may be appropriate having regard to the nature of the work.

▲ Figure 6.1 Extract from Electricity at Work Regulations 1989

How these regulations affect the inspection and testing process

The EAWR affects the inspection and testing process as follows:

- Regulation 4(1) – identifies the need to ensure that new electrical installations and circuits are subject to inspection, testing and commissioning before being put into service.
- Regulation 13 – identifies the need for equipment to be 'made dead' during the process of initial verification when undertaking **dead** tests. Isolation procedures will need to be adopted.

- Regulation 14 – identifies that working on or near **live** conductors will be necessary during initial verification, for example, in distribution boards and consumer units. Risk assessments, test equipment and safe working practices are covered in more detail in this chapter.
- Regulation 15 – involves working space, **access** and lighting. Good design and installation methods will ensure that access to electrical equipment is in accordance with these requirements.
- Regulation 16 – emphasises **competence** and the need to fully understand the task. There are many types of electrician – industrial, commercial and domestic, to name a few. When undertaking inspection, testing and commissioning, the duty holder must have the appropriate knowledge and experience of the system to work in a safe manner.

HEALTH AND SAFETY

The highlighted terms in the following phrase can act as a useful prompt for remembering Regulations 13, 14, 15 and 16 of the EAWR: **dead** or **live**, **access** with **competence**.

The correct procedure for safe isolation

Isolation can be very complex due to the differing industrial, commercial and domestic working environments, some of which require experience and knowledge of the system processes. This section deals with a basic practical procedure for the isolation and for the securing of isolation. It also looks at the reasons for safe isolation and the potential risks involved during the isolation process.

How to undertake a basic practical procedure for isolation

First, prepare all of the equipment required for this task. You will need the following equipment:

- a voltage indicator which has been manufactured and maintained in accordance with Health and Safety Executive (HSE) Guidance Note GS38
- a proving unit compatible with the voltage indicator
- a lock and/or multi-lock system (there are many types of lock available)
- warning notices which identify the work being carried out
- relevant personal protective equipment (PPE) that adheres to all site PPE rules.

INDUSTRY TIP

You can download HSE GS38 free from the HSE website. It is worth doing this and becoming familiar with it.



▲ Figure 6.2 Voltage indicator



▲ Figure 6.3 Proving unit



▲ Figure 6.4 Lock-out facility – can be used with one or more locks

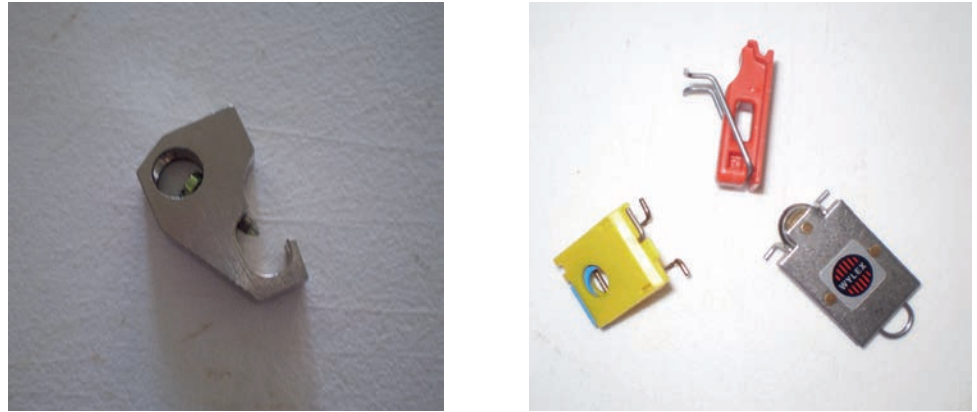

▲ Figure 6.5 Lock-out devices for circuit breakers and RCBs



▲ Figure 6.6 Typical warning notices

The equipment shown in the photographs can be used to isolate various main switches and isolators. To isolate individual circuit breakers with suitable locks and locking aids, you should consult the manufacturer's guidance. When working on or near electrical equipment and circuits, it is important to ensure that:

HEALTH AND SAFETY

Always make sure you check an approved voltage indicator for damage before using each time. Any damage can lead to electric shock.

- the correct point of isolation is identified
- an appropriate means of isolation is used
- the supply cannot inadvertently be reinstated while the work is in progress
- caution notices are applied at the point(s) of isolation
- conductors are proved to be dead at the point of work before they are touched
- safety barriers are erected as appropriate when working in an area that is open to other people.

Carry out the practical isolation

- 1 Identify – identify equipment or circuit to be worked on and point(s) of isolation.
- 2 Isolate – switch off, isolate and lock off (secure) equipment or circuit in an appropriate manner. Retain the key and post caution signs with details of work being carried out.
- 3 Check – check the condition of the voltage indicator leads and probes. Confirm that the voltage indicator is functioning correctly by using a proving unit.
- 4 Test – using voltage indicator, test the outgoing terminals of the isolation switch. Take precautions against adjacent live parts where necessary.

Single-phase isolation

During single-phase isolation there are three tests to be carried out:

- L – N
- L – E
- N – E

(L = Line, N = Neutral, E = Earth)

This is known as the three-point test.

Three-phase isolation

During three-phase isolation there are ten possible tests (if the neutral is present):

- L1 – N
- L2 – N
- L3 – N

- L1 – E
- L2 – E
- L3 – E

- L1 – L2
- L1 – L3
- L2 – L3

- N – E

(L = Line, N = Neutral, E = Earth)

This is known as the ten-point test.

- 5 Prove – using voltage indicator and proving unit, prove that the voltage indicator is still functioning correctly.
- 6 Confirm – confirm that the isolation is secure and the correct equipment has been isolated. This can be achieved by operating functional switching for the isolated circuit(s).
- 7 The relevant inspection and testing can now be carried out.

HEALTH AND SAFETY

Try to get into the habit of carrying out a current test using a clamp-meter on the earthing conductor before disconnecting it or any bonding. If there are any issues in a PME supply, diverted neutral current could be taking a path through that earthing and you could be the one who re-makes that circuit, causing shock.

Reinstate the supply

When the 'dead' electrical work is completed, you must ensure that all electrical barriers and enclosures are in place and that it is safe to switch on the isolated circuit.

- Remove the locking device and danger/warning signs.
- Reinstate the supply.
- Carry out system checks to ensure that the equipment is working correctly.

The requirements of the Electricity at Work Regulations

When undertaking the correct procedure for isolation, you will need to abide by Regulation 13 and Regulation 14, as shown in Figure 6.7.

PART II GENERAL – Electricity at Work Regulations 1989

Regulation 13 – Precautions for work on equipment made dead

Adequate precautions shall be taken to prevent electrical equipment, which has been made dead in order to prevent danger while work is carried out on or near that equipment, from becoming electrically charged during that work if danger may thereby arise.

Regulation 14 – Work on or near live conductors

No person shall be engaged in any work activity on or so near any live conductor (other than one suitably covered with insulating material so as to prevent danger) that danger may arise unless –
(a) it is unreasonable in all the circumstances for it to be dead

▲ Figure 6.7

HEALTH AND SAFETY

You can find additional information with in-depth explanations of the EAWR 1989 in relation to basic (and also to complex) isolation in the safe working practices booklet HSR25. This can be freely downloaded from the Health and Safety Executive (HSE) website.

How these regulations affect the inspection and testing process

The EAWR affects the inspection and testing process as follows.

- Regulation 13 identifies the need for equipment to be 'made dead' during the process of initial verification when undertaking dead tests. Isolation procedures will be needed.
- Regulation 14 acknowledges that during isolation, an electrician may be working on or near live conductors.

Safe isolation and implications

When you isolate an electricity supply, there will be disruption. So, careful planning should precede isolation of circuits. Consider isolating a section of a nursing home where elderly residents live. You will need to consult the nursing home staff to consider all the possible consequences of isolation and to prepare a procedure.

The following questions are useful before undertaking isolation to minimise issues:

- How will the isolation affect the staff and other personnel? For example, think about loss of power to lifts, heating and other essential systems.

- How could the isolation affect the residents and clients? For example, some residents may rely on oxygen, medical drips and ripple beds to aid circulation. These critical systems usually have battery back-up facilities for short durations.
- How could the isolation affect the members of the public? For example, fire alarms, nurse call systems, emergency lighting and other systems may stop working.
- How can an isolation affect systems? For example, IT programs and data systems could be affected; timing devices could be disrupted.

In this scenario, you must make the employers, employees, clients, residents and members of the public aware of the planned isolation. Alternative electrical back-up supplies may be required in the form of generators or uninterruptable power supply systems.

VALUES AND BEHAVIOURS

Remember to consider how any work might disrupt the client and make sure you communicate this clearly before commencing work.

Before any isolation is carried out, you must assess the risks involved. This section deals with the practical implications and the risks involved during the isolation procedure, if risk assessment and method statements are not followed.

Who is at risk and why?

If isolation is not carried out safely, what are the possible risks when performing inspection and testing tasks?

Risks to you

Risks to you might include:

- shock – touching a line conductor, e.g. if isolation is not secure
- burns – resulting from touching a line conductor and earth, or arcing
- arcing – due to a short circuit between live conductors, or an earth fault between a line conductor and earth
- explosion – arcing in certain environmental conditions, e.g. in the presence of airborne dust particles or gases, may cause an explosion.

Things that can cause risk to you include:

- inadequate information to enable safe or effective inspection and testing, i.e. no diagrams, legends or charts
- poor knowledge of the system you are working on (and so not meeting the competence requirements of Regulation 16 of EAWR)
- insufficient risk assessment
- inadequate test instruments (not manufactured or maintained to the standards of GS38).

Risks to other tradespersons, customers and clients

Risks to other tradespersons, customers and clients might include:

- switching off electrical circuits – e.g. switching off a heating system might cause hypothermia; if lifts stop, people may be trapped
- applying potentially dangerous test voltages and currents
- access to open distribution boards and consumer units
- loss of service or equipment, e.g.:
 - loss of essential supplies
 - loss of lights for access
 - loss of production.

HEALTH AND SAFETY

Note that, although safety services usually have back-up supplies such as batteries, these may only last for a few hours. Other safety or standby systems may have generator back-up, but this will also require isolation, leaving the building without any safety systems.

Risks to members of the public

Risks to members of the public might include prolonged loss of essential power supply, causing problems, for example, with safety and evacuation systems, such as:

- fire alarms
- emergency exit and corridor lighting.

Risks to buildings and systems within buildings

Risks to buildings and systems within buildings might involve applying excessive voltages to sensitive electronic equipment, for example:

- computers and associated IT equipment
- residual current devices (RCDs) and residual current operated circuit breakers with integral overcurrent protection (RCBOs)
- heating controls
- surge protection devices.

There might also be risk of loss of data and communications systems.

KEY TERM

Initial verification: The process of inspecting and testing an electrical installation for the first time, before it is put into service.

The purpose of inspection and testing

Inspection and testing of electrical installations is carried out for **initial verification** and for periodic inspection and testing:

- Initial verification – carried out to ensure that a new circuit (or installation) has been designed, installed, inspected and tested in accordance with **BS 7671**. This confirms that the installation is in a safe and suitable condition for use.
- Periodic inspecting and testing – carried out to assess the on-going safety of the existing electrical installation. This periodic report is not a certificate, since a certificate must have all inspection and test criteria in accordance with **BS 7671** with no faults or unsatisfactory comments. The periodic report allows for limitations and is used to give an overview of the on-going condition of the installation and whether it is suitable for continued use.

INDUSTRY TIP

If you think about it, any electrical product you buy comes with a safety certificate to say it is safe to use. Some products will need maintaining or repairing if they go wrong or become unsafe. An electrical installation is no different. Initial verification is the process to say the new installation is safe and suitable to be used, and periodic inspection and testing is part of the maintenance.

When an installation undergoes initial verification, three signatures are required on the certificate to state the installation is safe and suitable. The three persons who sign the certificate are:

- The designer – signs to state that the installation has been designed to be safe, suitable for the intended use and to comply with current regulations. If any part of their design does not comply with the regulations, they must declare this as a **departure**. As long as the departure does not leave the installation any less safe than what the regulations require, this is acceptable.
- The installer – signs to state that the installation has been constructed as designed and to the current regulations. Like the designer, the constructor must declare any departures.
- The inspector – signs to say that the inspection and testing process has been undertaken and that the installation is safe and suitable for the intended use and complies with the current regulations and that any departures are as safe as the regulations.

You can see that the initial verification process is very important to ensure that the installation is safe to be used, complies with regulations and is suitable for the intended use. The inspector who carries out the inspection and testing must be highly skilled and be able to fully understand all the risks that electricity can create.

To do this, the inspector needs to have a good understanding of all the statutory and non-statutory documents that relate to electrical installation work.

Statutory and non-statutory documentation, and requirements

Listed below are some of the documents (with explanations) that affect the processes of initial verification and periodic inspection and testing.

Statutory documents

There are six statutory documents that you need to abide by:

- The Health and Safety at Work Act 1974 (HSW Act) – imposes general duties on employers to ensure the health, safety and welfare at work of all employees. These duties apply to virtually everything in the workplace, including electrical systems and installations.
- The Electricity at Work Regulations 1989 (EAWR) – concerned specifically with electrical safety.

KEY TERM

Departure: A situation where the regulations could not be complied with. For example, Section 701 of BS 7671 states that socket outlets shall not be installed within 3 m of the edge of zone 1 of a shower tray. If the shower was in a leisure centre and a socket outlet was needed for cleaning purposes and it had to be installed 2 m from the shower, this would be a departure. As long as measures were taken to make it safe, this would be acceptable. These measures might be installing a key switch on the socket, so it can only be used by authorised people, and a risk assessment would show that the socket can only be used when the room is not in use.

- The Management of Health and Safety at Work Regulations 1999 – Regulation 3 requires every employer to carry out an assessment of the risks to workers and any others who may be affected.
- The Provision and Use of Work Equipment Regulations 1998 – apply to any machinery, appliance, apparatus or tool used for carrying out any work activity, whether or not electricity is involved. Regulation 5 requires such equipment to be maintained in an efficient state, in working order and in good repair. Also, any maintenance logs for machinery must be kept up to date.
- Electricity Safety, Quality and Continuity Regulations 2002 – apply to public and consumer safety with regard to electrical distribution and supply authorities.
- Part P of the Building Regulations – apply to electrical installations in domestic dwellings. While the EAWR places a statutory duty for electrical installations in places of work or public use to be safe, they do not include dwellings, so Part P is really an 'electricity at home regulations'.

KEY TERM

JPEL/64: A committee made up of representatives of many electrical industry organisations, the names of which are all listed at the front of BS 7671.

Non-statutory documents

The following non-statutory documents are important and are referred to throughout this book.

BS 7671: 2018 (2022) The IET Wiring Regulations, 18th Edition including Amendment 2

These regulations are based on internationally agreed documents – International Electrotechnical Commission (IEC) harmonised documents – and are international safety rules for electrical installations. A British Standards Institute (BSI) IET-led committee, known as **JPEL/64**, compiles a UK edition of these rules, selecting regulations specifically for the UK in agreement with a European committee known as CENELEC.

(Refer back to Chapter 3, BS 7671 Requirements for Electrical Installations, for more information on this.)

The IET On-Site Guide (OSG) to BS 7671

This is a simple guide to the requirements from the practical approach of designing, installing, inspecting and testing electrical installations. It can be used as a quick reference guide, but electrical installers should always consult **BS 7671** to satisfy themselves of compliance. It is expected that people carrying out work in accordance with this guide are competent to do so.

The IET Guidance Note 3: Inspection and Testing to BS 7671

This Guidance Note (GN) is one of a number of publications prepared by the IET, giving guidance to

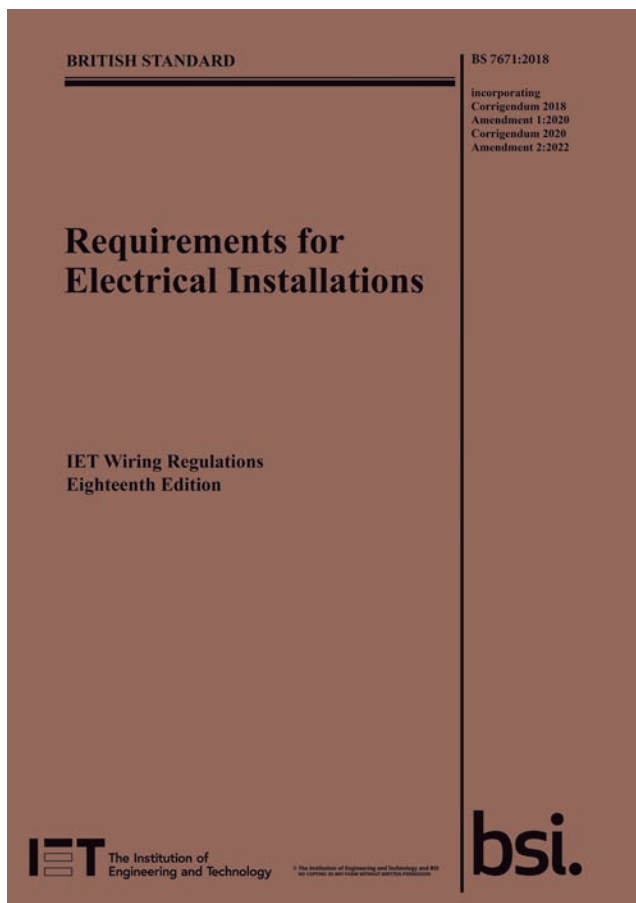

▲ Figure 6.8 BS 7671: 2018 (2022) The IET Wiring Regulations, 18th Edition including Amendment 2

BS 7671. GN3 is a descriptive guide to the requirements of BS 7671 and provides specific guidance on inspection and testing. Electrical installers should always consult BS 7671 to satisfy themselves of compliance. It is expected that people carrying out work in accordance with this guide are competent to do so.

HSE Guidance Note GS38: Electrical test equipment for use by electricians

Published by the Health and Safety Executive (HSE), this was written as a guideline to good practice when using test equipment. It is intended to be followed in order to reduce the risk of danger and injury when performing electrical tests. We will cover more on this later in this chapter.

Certification documentation

Within the non-statutory documentation, there are forms that must be completed for both initial verification and periodic inspections.

Initial verification documents

Initial verification forms must be completed for all new installations, new circuits, additions or alterations to existing circuits or replacement consumer units.

These forms are:

- Electrical Installation Certificate (EIC), which must include:
 - Schedule(s) of circuit details
 - Generic Schedule(s) of Test Results
- Minor Electrical Installation Works Certificate (MEIWC).

An EIC is used to certify any new installation, rewires or the installation of any one circuit. It is also used to certify a change of consumer unit or distribution board.

The MEIWC is used where an alteration or addition is made to an existing circuit, such as adding a light to an already working lighting circuit. If work involves alterations or additions to many circuits, an EIC could be used instead.

All documents must be completed and authenticated by a competent person(s) before certification is handed over.

Where additions to an electrical installation involve adding to several circuits, more than one MEIWC could be used, or an EIC could be used instead.

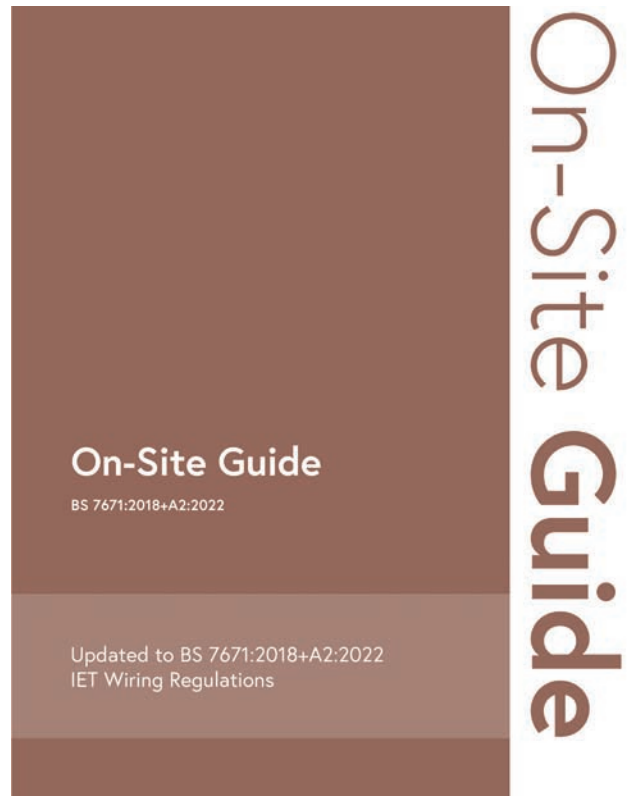

▲ Figure 6.9 IET On-Site Guide

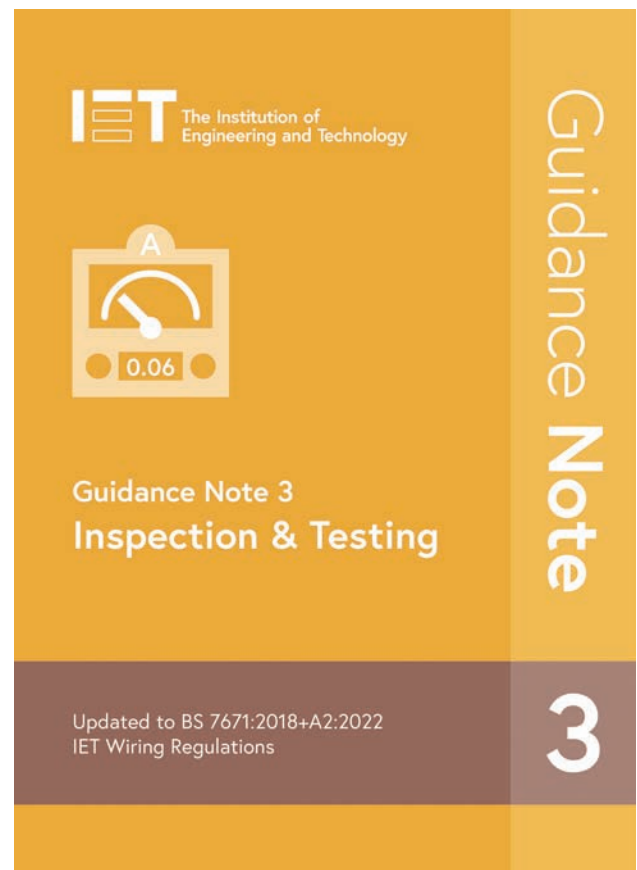

▲ Figure 6.10 IET Guidance Note 3

ELECTRICAL INSTALLATION CERTIFICATE (REQUIREMENTS FOR ELECTRICAL INSTALLATIONS - BS 7671)		Certificate No.:
DETAILS OF THE CLIENT		
INSTALLATION ADDRESS		
DESCRIPTION AND EXTENT OF THE INSTALLATION Description of installation:	New installation <input type="checkbox"/>	
Extent of installation covered by this Certificate: (Use continuation sheet if necessary)	Addition to an existing installation <input type="checkbox"/> Alteration to an existing installation <input type="checkbox"/>	
See continuation sheet No:		
FOR DESIGN I/We, being the person(s) responsible for the design of the electrical installation (as indicated by my/our signatures below), particulars of which are described above, having exercised reasonable skill and care when carrying out the design, hereby CERTIFY that the design work for which I/we have been responsible is to the best of my/our knowledge and belief in accordance with BS 7671:2018, amended to (date) except for the departures, if any, detailed as follows:		
Details of departures from BS 7671 (Regulations 120.3, 133.1.3 and 133.5):		
Details of permitted exceptions (Regulation 411.3.3). Where applicable, a suitable risk assessment(s) must be attached to this Certificate.		
Risk assessment attached <input type="checkbox"/>		
The extent of liability of the signatory or signatories is limited to the work described above as the subject of this Certificate.		
For the DESIGN of the installation: ** (Where there is mutual responsibility for the design)		
Signature: Date: Name (IN BLOCK CAPITALS): Designer No 1		
Signature: Date: Name (IN BLOCK CAPITALS): Designer No 2**		
FOR CONSTRUCTION I, being the person responsible for the construction of the electrical installation (as indicated by my signature below), particulars of which are described above, having exercised reasonable skill and care when carrying out the construction hereby CERTIFY that the work for which I have been responsible is to the best of my knowledge and belief in accordance with BS 7671:2018, amended to (date) except for the departures, if any, detailed as follows:		
Details of departures from BS 7671 (Regulations 120.3 and 133.5):		
The extent of liability of the signatory or signatories is limited to the work described above as the subject of this Certificate.		
For CONSTRUCTION of the installation:		
Signature: Date: Name (IN BLOCK CAPITALS): Constructor		
FOR INSPECTION AND TESTING I, being the person responsible for the inspection & testing of the electrical installation (as indicated by my signature below), particulars of which are described above, having exercised reasonable skill and care when carrying out the inspection & testing hereby CERTIFY that the work for which I have been responsible is to the best of my knowledge and belief in accordance with BS 7671:2018, amended to (date) except for the departures, if any, detailed as follows:		
Details of departures from BS 7671 (Regulations 120.3 and 133.5):		
The extent of liability of the signatory or signatories is limited to the work described above as the subject of this Certificate.		
For INSPECTION AND TESTING of the installation:		
Signature: Date: Name (IN BLOCK CAPITALS): Inspector		
NEXT INSPECTION I/We, the designer(s), recommend that this installation is further inspected and tested after an interval of not more than years/months.		

▲ Figure 6.11a Sample Electrical Installation Certificate (EIC)

Certificate No.:

PARTICULARS OF SIGNATORIES TO THE ELECTRICAL INSTALLATION CERTIFICATE					
Designer (No 1)	Name:	Company:	Address:		
	Address:	Postcode:	Tel No:		
Designer (No 2) (if applicable)	Name:	Company:	Address:		
	Address:	Postcode:	Tel No:		
Constructor	Name:	Company:	Address:		
	Address:	Postcode:	Tel No:		
Inspector	Name:	Company:	Address:		
	Address:	Postcode:	Tel No:		
SUPPLY CHARACTERISTICS AND EARTHING ARRANGEMENTS					
Earthing arrangements	Number and Type of Live Conductors		Nature of Supply Parameters	Supply Protective Device	
TN-C <input type="checkbox"/>	AC <input type="checkbox"/>		Nominal voltage, $U / U_0^{(1)}$ V	BS (EN)	
TN-S <input type="checkbox"/>	1-phase, 2-wire <input type="checkbox"/>	DC <input type="checkbox"/>	Nominal frequency, $f^{(1)}$ Hz	Type	
TN-C-S <input type="checkbox"/>	2-phase, 3-wire <input type="checkbox"/>	2-wire <input type="checkbox"/>	Prospective fault current, $I_{pf}^{(2)}$ kA	Rated current A	
TT <input type="checkbox"/>	3-phase, 3-wire <input type="checkbox"/>	3-wire <input type="checkbox"/>	External earth fault loop impedance, $Z_0^{(2)}$ Ω		
IT <input type="checkbox"/>	3-phase, 4-wire <input type="checkbox"/>	Other <input type="checkbox"/>			
	Confirmation of supply polarity <input type="checkbox"/>		<small>(Note: (1) by enquiry (2) by enquiry or by measurement)</small>		
Other sources of supply (as detailed on attached schedule) <input type="checkbox"/>					
PARTICULARS OF INSTALLATION REFERRED TO IN THE CERTIFICATE					
Means of Earthing		Maximum Demand			
Distributor's facility <input type="checkbox"/>		Maximum demand (load) kVA / Amps (Delete as appropriate)			
Installation earth electrode <input type="checkbox"/>		Details of Installation Earth Electrode (where applicable)			
		Type (e.g. rod(s), tape etc)			
		Location			
		Electrode resistance to Earth			
Main Protective Conductors					
Earthing conductor	Material	csa	mm ²	Connection / continuity verified <input type="checkbox"/>	
Main protective bonding conductors	Material	csa	mm ²	Connection / continuity verified <input type="checkbox"/>	
To water installation pipes <input type="checkbox"/> To gas installation pipes <input type="checkbox"/> To oil installation pipes <input type="checkbox"/> To structural steel <input type="checkbox"/> To lightning protection <input type="checkbox"/>					
To other <input type="checkbox"/> Specify					
Main switch / Switch-fuse / Circuit-breaker / RCD					
Location	Current rating	A		If RCD main switch	
BS (EN)	Fuse / device rating or setting	A			
No of poles	Voltage rating	V			
				RCD Type	
				Rated residual operating current ($I_{\Delta n}$) mA	
				Rated time delay	
				Measured operating time	
Schedule of Inspections					
Item No.	Description	Outcome ✓ / N/A	Item No.	Description	Outcome ✓ / N/A
1.0	Condition of consumer's intake equipment (Visual inspection only)		8.0	Circuits (Distribution and Final)	
			9.0	Isolation and switching	
2.0	Parallel or switched alternative sources of supply		10.0	Current-using equipment (permanently connected)	
3.0	Protective measure: Automatic Disconnection of Supply (ADS)		11.0	Identification and notices	
4.0	Basic protection		12.0	Location(s) containing a bath or shower	
5.0	Protective measures other than ADS		13.0	Other special installations or locations	
6.0	Additional protection		14.0	Prosumer's low voltage electrical installation(s)	
7.0	Distribution equipment				
COMMENTS ON EXISTING INSTALLATION (in the case of an addition or alteration see Regulation 644.1.2):					
.....					
.....					
.....					
.....					
SCHEDULES					
This Certificate is valid only when Schedules of Circuit Details and Test Results are attached. (Enter quantities of schedules attached).					

▲ Figure 6.11a Sample Electrical Installation Certificate (EIC) (continued)

GENERIC SCHEDULE OF TEST RESULTS

Certificate/Report No.:

Distribution board details

DB reference: Z_{db} Ω I_{pf} kA
 Confirmed: Correct polarity Phase sequence
 SPD: Operational status confirmed^{††} N/A

Details of test instruments used (serial and/or asset numbers)

Multifunction:
 Continuity:
 Insulation resistance:
 Earth fault loop impedance:
 RCD:
 Earth electrode resistance:

TEST RESULT DETAILS

Circuit number	Continuity (Ω)		Insulation resistance			Z_s (Ω)	RCD	AFDD	Remarks																				
	Ring final circuit	($R_1 + R_2$) or R_2	Test voltage (V)	Live - Live ($M\Omega$)	Live - Earth ($M\Omega$)																								
17	R_1 (line) (Ω)	18	19	R_2 (neutral)	20	R_2 (cpc)	21	($R_1 + R_2$)	22	R_2	23	Test voltage (V)	24	Live - Live ($M\Omega$)	25	Live - Earth ($M\Omega$)	26	Polarity#	27	Maximum measured	28	Disconnection time (ms)**	29	Test button operation	30	Manual test button operation	31		
				</																									

MINOR ELECTRICAL INSTALLATION WORKS CERTIFICATE
(REQUIREMENTS FOR ELECTRICAL INSTALLATIONS - BS 7671)

Certificate No.:

To be used only for minor electrical work which does not include the provision of a new circuit

PART 1: Description of the minor works

1. Details of the Client Date minor works completed
2. Installation location/address
3. Description of the minor works
4. Details of any departures from BS 7671:2018 as amended to (date) for the circuit altered or extended (Regulation 120.3, 133.1.3 and 133.5).
Details of permitted exceptions (Regulation 411.3.3). Where applicable, a suitable risk assessment(s) must be attached to this Certificate.
..... Risk assessment attached
5. **Comments on (including any defects observed in) the existing installation (Regulation 644.1.2):**
.....

PART 2: Presence and adequacy of installation earthing and bonding arrangements (Regulation 132.16)

1. System earthing arrangement: TN-S TN-C-S TT
2. Earth fault loop impedance at distribution board (Z_{db}) supplying the final circuit Ω
3. Presence of adequate main protective conductors:
Earthing conductor
Main protective bonding conductor(s) to: Water Gas Oil Structural steel Other (Specify).....

PART 3: Circuit details

DB Reference No.: DB Location and type:

Circuit No.: Circuit description: Installation reference method

Number & size of conductors: Live mm² cpc mm²

Circuit overcurrent protective device: BS (EN) Type Rating A

RCD: BS (EN) Type Rating A Rated residual operating current (I_{2n}) mA

AFDD: BS (EN) Rating A

SPD: BS (EN) Type

PART 4: Test results for the altered or extended circuit (where relevant and practicable)

Protective conductor continuity: ($R_1 + R_2$) Ω or R_2 Ω

Continuity of ring final circuit conductors: L/L Ω N/N Ω cpc/cpc Ω

Insulation resistance: Test voltage V Live - Live M Ω Live - Earth M Ω

Polarity satisfactory: Maximum measured earth fault loop impedance: Z_s Ω

RCD disconnection time at rated residual operating current (I_{2n}) ms Satisfactory test button operation:

AFDD satisfactory test button operation: NOTE: Not all AFDDs have a test button

SPD functionality confirmed: NOTE: Not all SPDs have visible functionality indication

PART 5: Declaration

I certify that the work covered by this certificate does not impair the safety of the existing installation and the work has been designed, constructed, inspected and tested in accordance with BS 7671:2018 amended to (date) and that to the best of my knowledge and belief, at the time of my inspection, complied with BS 7671 except as detailed in Part 1 above.

Name:

For and on behalf of:

Address:

.....

.....

.....

Signature:

Position:

Date:

▲ Figure 6.11d Sample MEIWC

INDUSTRY TIP

The sample documents are shown in Figure 6.11 but always check you are using the latest forms, as found on the IET website under model forms. Also make sure you read any accompanying notes, which may not be shown here.

These forms can also be found in Appendix 6 of BS 7671 and examples of completed documents are contained in the IET On-Site Guide or Guidance Note 3.

Periodic inspection and testing forms

Periodic inspection and testing is carried out to assess the on-going safety of existing electrical installations.

The following forms are blank samples. These forms are not classed as certification; they are reports relating to the condition of the electrical installation. The **extent** and **limitations** of the report must be agreed with the person ordering the work. The reasons for these limitations must be validated.

While this chapter focuses on the initial verification process, it is a good idea to see the forms used for periodic inspection and testing in order to understand how they differ. More information on periodic inspection and testing will be covered in Chapter 7, including reporting unsafe situations and the use of the report codes. The schedule of test results used for a periodic inspection and test is the same as that used for an EIC.

All documents must be completed and authenticated by a competent person(s) before a full report is handed over.

Documentation to be completed for periodic inspection and testing can also be found in Appendix 6 of **BS 7671** and on the IET website:

- Electrical Installation Condition Report
- Condition Report Inspection Schedule(s)
- Generic Schedule(s) of Test Results, and circuit details (which is the same as that used for an EIC).

KEY TERMS

Extent: The amount of inspection and testing. For example, in a third-floor flat with a single distribution board and eight circuits, the inspection will be visual only without removing covers and testing, and will involve sample tests at the final point of each circuit.

Limitation: A part of the inspection and test process that cannot be done for operational reasons. For example, the main protective bonding connection to the water system, located in the basement, could not be inspected as a key for the room was not available.

There are two types of limitations:

- Agreed limitations which are made before work begins. This may be, for example, where a certain safety circuit cannot be turned off.
- Operational limitations which are situations that arise during the work. This could be, for example, where a room was supposed to be inspected, but the person with the key was not available so access was not possible.

ELECTRICAL INSTALLATION CONDITION REPORT		Report No.:
SECTION A. DETAILS OF THE PERSON ORDERING THE REPORT		
Name		
Address		
.....		
SECTION B. REASON FOR PRODUCING THIS REPORT		
Date(s) on which inspection and testing was carried out		
.....		
SECTION C. DETAILS OF THE INSTALLATION WHICH IS THE SUBJECT OF THIS REPORT		
Occupier		
Address		
.....		
Description of premises		
Residential <input type="checkbox"/> Commercial <input type="checkbox"/> Industrial <input type="checkbox"/> Other (include brief description) <input type="checkbox"/>		
Estimated age of wiring system years		
Evidence of additions / alterations? Yes <input type="checkbox"/> No <input type="checkbox"/> Not apparent <input type="checkbox"/> If yes, estimate age years		
Installation records available? (Regulation 651.1) Yes <input type="checkbox"/> No <input type="checkbox"/> Date of last inspection (date)		
.....		
SECTION D. EXTENT AND LIMITATIONS OF INSPECTION AND TESTING		
Extent of the electrical installation covered by this report		
.....		
Agreed limitations including the reasons (see Regulation 653.2)		
.....		
Agreed with:		
Operational limitations including the reasons (see page no.....)		
.....		
The inspection and testing detailed in this report and accompanying schedules have been carried out in accordance with BS 7671:2018 as amended to		
.....		
It should be noted that cables concealed within trunking and conduits, under floors, in roof spaces, and generally within the fabric of the building or underground, have not been inspected unless specifically agreed between the client and inspector prior to the inspection. An inspection should be made within an accessible roof space housing other electrical equipment.		
.....		
SECTION E. SUMMARY OF THE CONDITION OF THE INSTALLATION		
General condition of the installation (in terms of electrical safety)		
.....		
.....		
Overall assessment of the installation in terms of its suitability for continued use SATISFACTORY / UNSATISFACTORY* (Delete as appropriate)		
*An unsatisfactory assessment indicates that dangerous (code C1) and/or potentially dangerous (code C2) conditions have been identified.		
.....		
SECTION F. RECOMMENDATIONS		
Where the overall assessment of the suitability of the installation for continued use above is stated as UNSATISFACTORY, I / we recommend that any observations classified as ' <i>Danger present</i> ' (code C1) or ' <i>Potentially dangerous</i> ' (code C2) are acted upon as a matter of urgency. Investigation without delay is recommended for observations identified as ' <i>Further investigation required</i> ' (code FI). Observations classified as ' <i>Improvement recommended</i> ' (code C3) should be given due consideration.		
Subject to the necessary remedial action being taken, I / We recommend that the installation is further inspected and tested by (date) for the following reasons.....		
.....		
SECTION G. DECLARATION		
I/We, being the person(s) responsible for the inspection and testing of the electrical installation (as indicated by my/our signatures below), particulars of which are described above, having exercised reasonable skill and care when carrying out the inspection and testing, hereby declare that the information in this report, including the observations and the attached schedules, provides an accurate assessment of the condition of the electrical installation taking into account the stated extent and limitations in section D of this report.		
Inspected and tested by:		Report authorised for issue by:
Name (Capitals)	Name (Capitals)	Name (Capitals)
Signature	Signature	Signature
For/on behalf of	For/on behalf of	For/on behalf of
Position	Position	Position
Address	Address	Address
Date	Date	Date
SECTION H. SCHEDULE(S)		
..... Inspection Schedule(s) and Schedule(s) of Circuit Details and Test Results are attached.		
The attached schedule(s) are part of this document and this report is valid only when they are attached to it.		

▲ Figure 6.12a Sample Electrical Installation Condition Report (page 1)

CONDITION REPORT INSPECTION SCHEDULE FOR RESIDENTIAL AND SIMILAR PREMISES WITH UP TO 100 A SUPPLY														Report No.:
NOTE: This form is suitable for many types of smaller installation, not exclusively residential. The persons responsible for the periodic inspection of the installation should include the relevant items in relation to the electrical installation, the inspection schedule can be reduced or expanded depending on the requirements for the installation.														
Outcomes	Acceptable condition	✓	Unacceptable condition	C1 or C2	Improvement recommended	C3	Further investigation	FI	Not verified	N/V	Limitation	LIM	Not applicable	N/A
Item No	Description									Outcome (Use codes above. Provide additional comment where appropriate. C1, C2, C3 and FI coded items to be recorded in Section K of the Condition Report)				
1.0	INTAKE EQUIPMENT (VISUAL INSPECTION ONLY) An outcome against an item in this section, other than access to live parts, should not be used to determine the overall outcome.													
1.1	<ul style="list-style-type: none"> - Service cable - Service head - Earthing arrangement - Meter tails - Metering equipment - Isolator (where present) <p>NOTE 1: Where inadequacies in the intake equipment are encountered, which may result in a dangerous or potentially dangerous situation, the person ordering the work and/or dutyholder must be informed. It is strongly recommended that the person ordering the work informs the appropriate authority.</p> <p>NOTE 2: For this section only, where inadequacies are found, an 'X' should be put against the appropriate item and a comment made in Section K.</p>													
	Person ordering work/dutyholder notified (Delete as appropriate)									Y / N/A				
1.2	Consumer's isolator (where present)													
1.3	Consumer's meter tails													
2.0	PRESENCE OF ADEQUATE ARRANGEMENTS FOR OTHER SOURCES SUCH AS MICROGENERATORS (551.6; 551.7)													
3.0	EARTHING / BONDING ARRANGEMENTS (411.3; Chap 54)													
3.1	Presence and condition of distributor's earthing arrangement (542.1.2.1; 542.1.2.2)													
3.2	Presence and condition of earth electrode connection where applicable (542.1.2.3)													
3.3	Provision of earthing/bonding labels at all appropriate locations (514.13.1)													
3.4	Confirmation of earthing conductor size (542.3; 543.1.1)													
3.5	Accessibility and condition of earthing conductor at MET (543.3.2)													
3.6	Confirmation of main protective bonding conductor sizes (544.1)													
3.7	Condition and accessibility of main protective bonding conductor connections (543.3.2; 544.1.2)													
3.8	Accessibility and condition of other protective bonding connections (543.3.1; 543.3.2)													
4.0	CONSUMER UNIT(S) / DISTRIBUTION BOARD(S)													
4.1	Adequacy of working space/accessibility to consumer unit/distribution board (132.12; 513.1)													
4.2	Security of fixing (134.1.1)													
4.3	Condition of enclosure(s) in terms of IP rating etc (416.2)													
4.4	Condition of enclosure(s) in terms of fire rating etc (421.1.201; 526.5)													
4.5	Enclosure not damaged/deteriorated so as to impair safety (651.2)													
4.6	Presence of main linked switch (as required by 462.1.201)													
4.7	Operation of main switch (functional check) (643.10)													
4.8	Manual operation of circuit-breakers and RCDs to prove disconnection (643.10)													
4.9	Correct identification of circuit details and protective devices (514.8.1; 514.9.1)													
4.10	Presence of RCD six-monthly test notice, where required (514.12.2)													
4.11	Presence of alternative supply warning notice at or near consumer unit/distribution board (514.15)													
4.12	Presence of other required labelling (please specify) (Section 514)													

▲ Figure 6.12c Sample condition report inspection schedule (page 1)

CONDITION REPORT INSPECTION SCHEDULE FOR RESIDENTIAL AND SIMILAR PREMISES WITH UP TO 100 A SUPPLY											Report No.:			
NOTE: This form is suitable for many types of smaller installation, not exclusively residential. The persons responsible for the periodic inspection of the installation should include the relevant items in relation to the electrical installation, the inspection schedule can be reduced or expanded depending on the requirements for the installation.														
Outcomes	Acceptable condition	✓	Unacceptable condition	C1 or C2	Improvement recommended	C3	Further investigation	FI	Not verified	N/V	Limitation	LIM	Not applicable	N/A
Item No	Description									Outcome (Use codes above. Provide additional comment where appropriate. C1, C2, C3 and FI coded items to be recorded in Section K of the Condition Report)				
4.13	Compatibility of protective devices, bases and other components; correct type and rating (No signs of unacceptable thermal damage, arcing or overheating) (411.3.2; 411.4; 411.5; 411.6; Sections 432, 433)													
4.14	Single-pole switching or protective devices in line conductor only (132.14.1; 530.3.3)													
4.15	Protection against mechanical damage where cables enter consumer unit/distribution board (522.8.1; 522.8.5; 522.8.11)													
4.16	Protection against electromagnetic effects where cables enter consumer unit/distribution board/enclosures (521.5.1)													
4.17	RCD's provided for fault protection - includes RCBOs (411.4.204; 411.5.2; 531.2)													
4.18	RCD(s) provided for additional protection/requirements - includes RCBOs (411.3.3; 415.1)													
4.19	Confirmation of indication that SPD is functional (651.4)													
4.20	Confirmation that ALL conductor connections, including connections to busbars, are correctly located in terminals and are tight and secure (526.1)													
4.21	Adequate arrangements where a generating set operates as a switched alternative to the public supply (551.6)													
4.22	Adequate arrangements where a generating set operates in parallel with the public supply (551.7)													
5.0	FINAL CIRCUITS													
5.1	Identification of conductors (514.3.1)													
5.2	Cables correctly supported throughout their run (521.10.202; 522.8.5)													
5.3	Condition of insulation of live parts (416.1)													
5.4	Non-sheathed cables protected by enclosure in conduit, ducting or trunking (521.10.1) • To include the integrity of conduit and trunking systems (metallic and plastic)													
5.5	Adequacy of cables for current-carrying capacity with regard for the type and nature of installation (Section 523)													
5.6	Coordination between conductors and overload protective devices (433.1; 533.2.1)													
5.7	Adequacy of protective devices: type and rated current for fault protection (411.3)													
5.8	Presence and adequacy of circuit protective conductors (411.3.1; Section 543)													
5.9	Wiring system(s) appropriate for the types and nature of the installation and external influences (Section 522)													
5.10	Concealed cables installed in prescribed zones (see Section D. Extent of limitations) (522.6.202)													
5.11	Cables concealed under floors, above ceilings or in walls/partitions, adequately protected against damage (see Section D. Extent and limitations) (522.6.2.4)													
5.12	Provision of additional requirements for protection by RCD not exceeding 30 mA • for all socket-outlets of rating 32 A or less, unless an exception is permitted (411.3.3) • for the supply of mobile equipment not exceeding 32 A rating for use outdoors (411.3.3) • for cables concealed in walls at a depth of less than 50 mm (522.6.202; 522.6.203) • for cables concealed in walls/partitions containing metal parts regardless of depth (522.6.203) • Final circuits supplying luminaires within domestic (household) premises (411.3.4)													
5.13	Provision of fire barriers, sealing arrangements and protection against thermal effects (Section 527)													
5.14	Band II cables segregated/separated from Band I cables (528.1)													
5.15	Cables segregated/separated from communications cabling (528.2)													

▲ Figure 6.12d Sample condition report inspection schedule (page 2)

CONDITION REPORT INSPECTION SCHEDULE FOR RESIDENTIAL AND SIMILAR PREMISES WITH UP TO 100 A SUPPLY

Report No.:

NOTE: This form is suitable for many types of smaller installation, not exclusively residential.

The persons responsible for the periodic inspection of the installation should include the relevant items in relation to the electrical installation, the inspection schedule can be reduced or expanded depending on the requirements for the installation.

Outcomes	Acceptable condition	✓	Unacceptable condition	C1 or C2	Improvement recommended	C3	Further investigation	FI	Not verified	N/V	Limitation	LIM	Not applicable	N/A
Item No	Description										Outcome (Use codes above. Provide additional comment where appropriate. C1, C2, C3 and FI coded items to be recorded in Section K of the Condition Report)			
5.16	Cables segregated/separated from non-electrical services (528.3)													
5.17	Termination of cables at enclosures - indicate extent of sampling in Section D of the report (Section 526) • Connections soundly made and under no undue strain (526.6) • No basic insulation of a conductor visible outside enclosure (526.8) • Connections of live conductors adequately enclosed (526.5) • Adequately connected at point of entry to enclosure (glands, bushes etc.) (522.8.5)													
5.18	Condition of accessories including socket-outlets, switches and joint boxes (651.2(v))													
5.19	Suitability of accessories for external influences (512.2)													
5.20	Adequacy of working space/accessibility to equipment (132.12; 513.1)													
5.21	Single-pole switching or protective devices in line conductors only (132.14.1; 530.3.3)													
6.0	LOCATION(S) CONTAINING A BATH OR SHOWER													
6.1	Additional protection for all low voltage (LV) circuits by RCD not exceeding 30 mA (701.411.3.3)													
6.2	Where used as a protective measure, requirements for SELV or PELV met (701.414.4.5)													
6.3	Shaver supply units comply with BS EN 61558-2-5 formerly BS 3535 (701.512.3)													
6.4	Presence of supplementary bonding conductors, unless not required by BS 7671:2018 (701.415.2)													
6.5	Low voltage (e.g. 230 V) socket-outlets sited at least 2.5 m from zone 1 (701.512.3)													
6.6	Suitability of equipment for external influences for installed location in terms of IP rating (701.512.2)													
6.7	Suitability of accessories and controlgear etc. for a particular zone (701.512.3)													
6.8	Suitability of current-using equipment for particular position within the location (701.55)													
7.0	OTHER PART 7 SPECIAL INSTALLATIONS OR LOCATIONS													
7.1	List all other special installations or locations present, if any. (Record separately the results of particular inspections applied.)													
8.0	PROSUMER'S LOW VOLTAGE ELECTRICAL INSTALLATION(S)													
8.1	Where the installation includes additional requirements and recommendations relating to Chapter 82, additional inspection items should be added to the checklist.													

Inspected by:

Name (Capitals) Signature Date

▲ Figure 6.12e Sample condition report inspection schedule (page 3)

Information required to carry out initial verification of an electrical installation

Before carrying out an initial verification of an electrical installation, you need the following information, in accordance with **BS 7671** The IET Wiring Regulations, 18th Edition and IET Guidance Note 3:

- maximum demand and diversity (Regulation 311)
- conductor and system earthing arrangements (TN or TT system) (Regulation 312)
- supply characteristics such as nominal voltage, current, frequency, prospective short-circuit current and external earth fault loop impedance (Z_e) (Regulation 313)
- diagrams, documents, plans and design criteria for the building (Regulation 514.9.1).

Maximum demand and diversity (Regulation 311)

The maximum demand of a new installation must be assessed. Appendix A of the IET OSG provides details of the methods used to calculate the maximum demand and diversity of small installations. We also covered other methods in Chapter 5, pages 316–22.

The assessed demand after diversity must be inserted on the Electrical Installation Certificate. This information should be provided by the designer but in many cases, the maximum demand is based on the rating of the supplier's fuse.

Conductor and system earthing arrangements (TN or TT system) (Section 312)

Understanding the system earthing arrangements is one of the most important parts of the inspection and testing process.

Supply characteristics (Section 313)

The following values are for low-voltage public electricity supply systems:

- the **nominal** voltage to earth (U_0) is 230 V and the nominal voltage (U) could either be 230 V for single-phase or 400 V for three-phase
- the current is normally alternating current (AC)
- the frequency is 50 Hz
- the prospective fault current (PFC) will vary with every installation
- the external earth fault loop impedance (Z_e) will vary with every system, supply arrangements and, therefore, installation.

The inspector needs to know these characteristics as some tests depend on them as well as results.

INDUSTRY TIP

These regulation numbers are from **BS 7671: 2018 (2022)** The IET Wiring Regulations, 18th Edition.

KEY TERM

Nominal: An expected value but in reality the value is different.

INDUSTRY TIP

Although the voltage you measure may be different from 230 V or 400 V, these values are still recorded as they are the nominal voltages. Nominal value is covered in depth in Chapters 2 and 3 of this book; see also page 274. Although the supply characteristics are, in the UK, as given here and you may remember these, technically, the only way you can determine the nominal voltage and frequency is by enquiry to the DNO. The external loop impedance (Z_e) and prospective fault current (I_{pf}) can be measured as well as found by enquiry.

Diagrams, documents, plans and design criteria for the building (BS 7671 Regulation 514.9.1)

The inspection and certification process requires documentation to be available for the person carrying out the work.

Regulation 514.9.1 lists the following:

INDUSTRY TIP

If you look at a schedule of circuit details, the information required by Regulation 514.9.1 is the set of information on the left-hand side of the form, so the inspector must have this to complete the form. As well as this, the inspector must have this information for both safety reasons and effective testing.

A diagram, chart or table or equivalent form of information shall be provided indicating:

- (i) the type and composition of each circuit (points of utilisation served, number and size of conductors, type of wiring)
- (ii) the method used for compliance with Regulation 410.3.2, for basic protective measures and independent fault protection. Additional protection may need to be considered under certain conditions
- (iii) the information necessary for the identification of each device performing the functions of protection, isolation and switching, and its location
- (iv) any circuit or equipment vulnerable to a typical test.

For simple installations the foregoing information may be given in a schedule. A durable copy of the schedule relating to a distribution board shall be provided within or adjacent to each distribution board.

▲ Figure 6.13 Extract from BS 7671: 2018 (2022) The IET Wiring Regulations

BS 7671 now states that the above information need not be supplied in the form of a chart or table for a domestic (household) installation, providing the necessary certification has been given detailing that information.

THE INSPECTION PROCESS

Much emphasis is put on testing installations as it is probably seen as the more technical side of the process, but it must be remembered that testing only reinforces the results of an inspection. The inspection is an incredibly important stage and detailed inspection of a new installation should occur during and on completion of the work.

In this section we will look at what needs inspecting, how we do it and what human senses we use throughout the inspection.

Human senses and inspection

Human senses, your sight, touch, hearing and smell, are vital to the inspection process. You need to know which senses are involved and be able to explain how to use them.

INDUSTRY TIP

There are five senses. Taste is not used in the inspection and testing process, but hearing, touch, sight and smell are used.

Using senses during inspection of electrical installations

Inspection is normally done with that part of the installation under inspection disconnected from the supply, in accordance with Regulation 642.1. The examples below show how to apply the human senses during the stages of initial verification. **Those stages highlighted in red usually occur when the installation is switched on.**

Sight

Sight is the most extensively used sense. It is used when:

- connecting conductors
- identifying circuits
- routing cables
- labelling circuits
- correctly connecting accessories
- identifying **signs of burning or overheating due to bad connection.**

Touch

Touch is used in:

- connection of conductors (using a screwdriver to check the connections)
- correct connection to equipment (e.g. in the physical connection to a water pipe)
- erection methods (e.g. fixings for distribution boards (DBs)/conduits/trunking)
- checking of barriers and enclosures (check for IPXXB and IPXXD in accordance with Regulation 416.2)
- checking for careless work methods (sharp edges in conduit)
- **detecting overheating of equipment.**

Hearing

Listening can detect:

- **arcing caused by loading, e.g. when switching on and off fluorescent fittings**
- **equipment noise, such as a motor bearing problem that causes a loud grinding sound**
- **arcing caused by insecure connections, e.g. at an accessory, junction box or distribution board.**

Smell

Smell is used to detect:

- **equipment that is overheating**
- **loose connections under load conditions**
- **burning of adjacent building materials, e.g. recessed lights without fire protection.**

Inspection items explained

Regulation 642.3 in **BS 7671** The IET Wiring Regulations, lists items that should be checked during the inspection. The list is not entirely compatible with the schedule of inspections for new works. The schedule uses these items but targets them to specific areas within the installation. Later we will see the schedule and how to use it but here we will take a simplistic look at the items listed in Chapter 64.

Below is a summary, with brief description, of what should be inspected to ensure the safety of an installation as detailed in Chapter 64. The list is not necessarily in the same order nor complete as some of the common specific inspections are detailed within the schedule of inspections later in this section.

INDUSTRY TIP

Chapter 64 is the first Chapter in Part 6 of **BS 7671** and details the requirements for initial verification. So why doesn't Part 6 start with Chapter 61? Well, in the 17th Edition it did, but Part 6 was reordered in the 18th Edition to include the reporting and certification requirements in the correct chapter. As this meant merging three chapters into two, it was decided to create two new chapter numbers to highlight the changes. As a result, Chapters 61 to 63 have now been deleted.

ACTIVITY

As you go through the list of inspections, consider what human sense you would use to carry out the inspection.

(i) Connection of conductors

Every connection between a conductor and equipment (or another conductor) should provide durable electrical continuity and adequate mechanical strength.

(ii) Identification of cables and conductors

Check that each core or bare conductor is identified as necessary.

(iii) Routing of cables

Cables and their cable management systems should be designed and installed to take into account the mechanical stresses that users will place on the installation.

(iv) Selection of conductors for current-carrying capacity and voltage drop

Where practicable, the cable size should be assessed against the protective devices for the circuit. In cases of doubt, the inspector should check this against the design to confirm the installer has followed the design.

(v) Connection of single-pole devices for protection or switching in line conductor only

Checking that switches and protective devices are controlling or protecting the line conductor. This can also be verified through testing.

(vi) Correct connection of accessories and equipment

Correct connection (suitability and polarity) and environmental conditions, such as the presence of dust or moisture, must be checked.

(vii) Presence of fire barriers, suitable seals and protection against thermal effects

Fire barriers, suitable seals and/or protection against thermal effects should be provided. These checks should be carried out during the installation process.

(viii) Methods of protection against electric shock

There are two general methods against electric shock. Basic protection, which protects against shock through contact with parts that are normally live, and fault protection, which is protection against parts made live due to a fault.

a. Both basic and fault protection

This applies where SELV, PELV or double and reinforced protection is used for basic and fault protection. SELV and PELV systems use extra-low voltages where double and reinforced protection is the use of class II protection.

b. Basic protection

Basic protection is most commonly provided by insulation of live parts and/or barriers and enclosures:

- Confirmation of the insulation of live parts should be carried out to ensure no damage has occurred during the installation process.
- Barriers and enclosures need to be checked to ensure a protection level of at least IPXXB or IP2X. For horizontal top surfaces of readily accessible enclosures, you must ensure at least IPXXD or IP4X.

The illustrations and tables that follow explain the **IP codes designated numbering and lettering system**.

IP codes indicate the degree of ingress protection. Figure 6.14 (below) shows the designated numbers and letters in the code, and Table 6.2 shows the characteristic numerals. Where a characteristic numeral does not have to be specified, it can be replaced by the letter 'X' ('000' if both numbers are omitted).

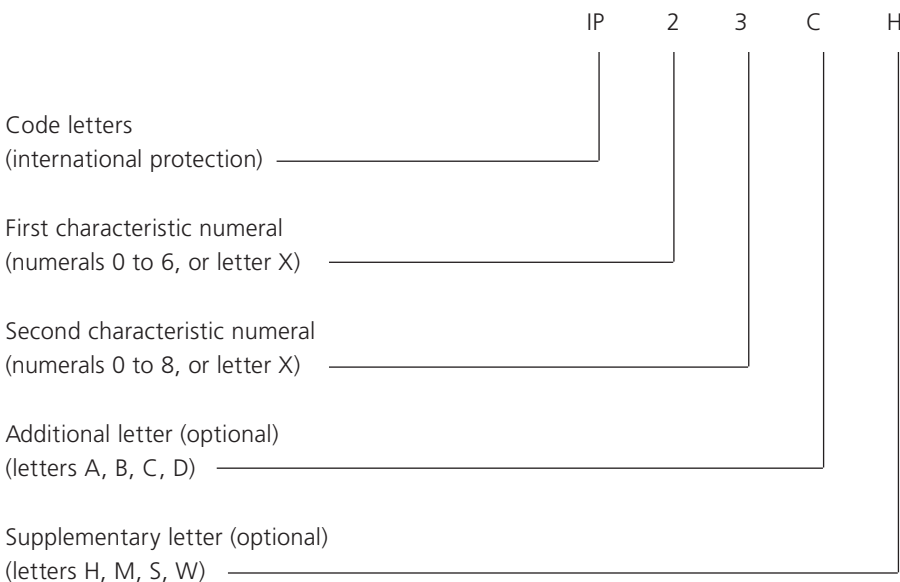

▲ Figure 6.14 IP code designated numbers and letters

IP characteristic numerals

The IP characteristic numerals are shown in Table 6.2.

▼ Table 6.2 IP code numbers and letter codes from IET Guidance Note 1: Selection and Erection of Equipment

First characteristic numeral		Second characteristic numeral	
(a) Protection of persons against access to hazardous parts inside enclosures (b) Protection of equipment against ingress of solid foreign objects		Protection of equipment against ingress of water	
No.	Degree of protection	No.	Degree of protection
0	(a) Not protected (b) Not protected	0	Not protected
1	(a) Protection against access to hazardous parts with the back of the hand (b) Protection against foreign solid objects of 50 mm diameter and greater	1	Protection against vertically falling water drops
2	(a) Protection against access to hazardous parts with a finger (b) Protection against solid foreign objects of 12.5 mm diameter and greater	2	Protected against vertically falling water drops when enclosure tilted up to 15°. Vertically falling water drops shall have no harmful effect when the enclosure is tilted at any angle up to 15° from the vertical
3	(a) Protection against contact by tools, wires or such like more than 2.5 mm thick (b) Protection against solid foreign objects of 2.5 mm diameter and greater	3	Protected against water spraying at an angle up to 60° on either side of the vertical
4	(a) As 3 above but against contact with a wire or strips more than 1.0 mm thick (b) Protection against solid foreign objects of 1.0 mm diameter and greater	4	Protected against water splashing from any direction
Additional letter		Brief description of protection	
A		Protected against access with the back of the hand (minimum 50 mm diameter sphere) (adequate clearance from live parts)	
B		Protected against access with a finger (minimum 12 mm diameter test finger, 80 mm long) (adequate clearance from live parts)	
C		Protected against access with a tool (minimum 2.5 mm diameter tool, 100 mm long) (adequate clearance from live parts)	
D		Protected against access with a wire (minimum 1 mm diameter wire, 100 mm long) (adequate clearance from live parts)	

Source: Guidance Note 1: Selection and Erection of Equipment, IET

Protection against access with a finger can be assessed using the British Standard finger (IPXXB), as shown in Figure 6.15.

Remember that the IP codes are used in conjunction with basic protection, as a guide to protection against contact with live parts and ingress of foreign bodies.

Note also that providing obstacles and placing installations out of reach are methods of protection against contact, but they can only be used as a method of protection in a controlled and supervised environment.

c. Fault protection

Fault protection inspection involves ensuring that earthing arrangements are in place. Part of this process includes automatic disconnection of supply, selection of protective devices and disconnection times, which will undergo further inspection and verification as you progress through the tests.

There are also some specialised systems of electric shock protection which are rarely used. They can be found in Section 418 of **BS 7671** and include:

- non-conducting location
- earth-free local equipotential bonding
- electrical separation for the supply to more than one item of current-using equipment.

Electrical separation for the supply to one item of equipment is more common. This may include the shaver point in a bathroom and confirming it is installed in the correct zone and complies with the correct standards.

Automatic disconnection of supply

The most common form of fault protection is automatic disconnection of supply (ADS). In order for ADS to be effective, a system of earthing and bonding is required.

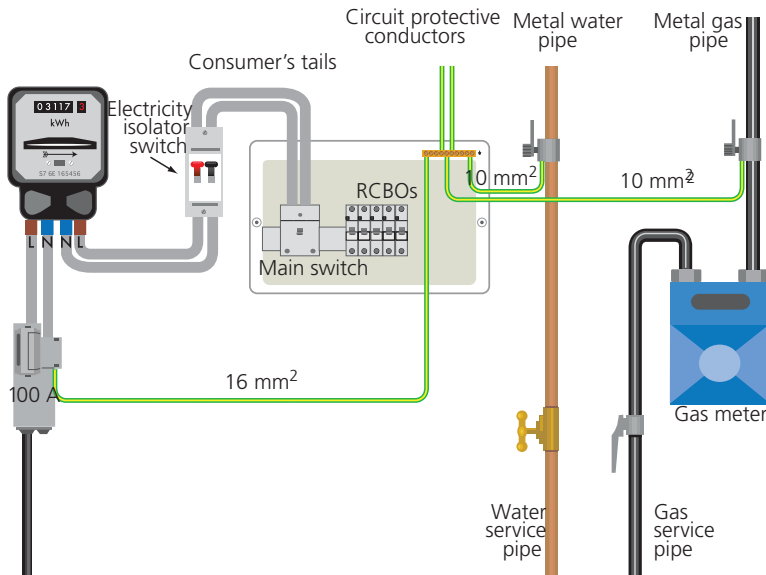

▲ Figure 6.16 Typical earthing and bonding arrangements for a simple single-phase supply

To inspect the earthing and bonding, the following is inspected:

- Presence of earthing conductor (shown as a 16 mm² cable)**
 - Check that the cable is continuous from the origin of the supply to the main earthing terminal (MET), consumer unit or distribution board.
 - Ensure that the connections are secure.
 - Ensure that the cable fixings are adequate.
 - Verify the cross-sectional area of the conductor and compare with calculation or selection in accordance with Regulation 543.1.1.

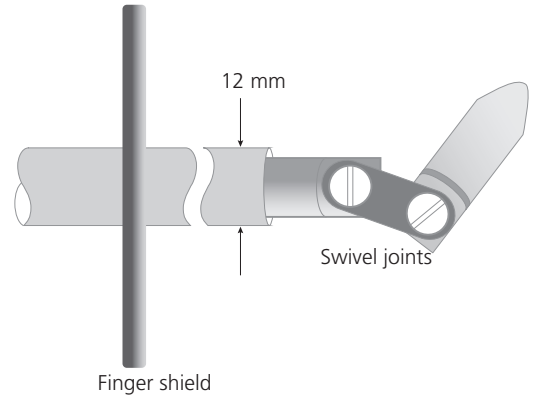

▲ Figure 6.15 British Standard finger (IPXXB)

- Ensure that the supply authority has supplied an earth connection at the origin (for TN-S and TN-C-S systems).
- Ensure that the earth electrode is installed correctly and that the cables are installed in accordance with Table 54.1 of BS 7671 for minimum cross-sectional area (TT system).
- ii. Presence of main protective bonding conductors (shown as a 10 mm² cable)**
 - Check that the cable is continuous from the MET to the water, gas structural metalwork and any other extraneous conductive parts in accordance with Regulation 411.3.1.2. (Where the cable is hidden for part of its length, this must be verified by test.)
 - Ensure that the connections are secure.
 - Ensure that the cable fixings are adequate.
 - Verify the cross-sectional area of the conductor and compare with Table 54.8 of BS 7671 for TN-C-S systems.
 - Verify the cross-sectional area of the conductor and compare with Regulation 544.1.1 for TN-S and TT systems.
- iii. Presence of supplementary protective bonding conductors**
 - Ensure that the conductors are appropriately installed.
 - Ensure that the connections are secure.
 - Ensure that the cable fixings are adequate.
 - Verify that the conductors are sized in accordance with Regulation section 544.2.3:

‘A supplementary bonding conductor connecting two extraneous conductive parts shall have a cross-sectional area not less than 2.5 mm² if sheathed or otherwise provided with mechanical protection or 4 mm² if mechanical protection is not provided.’
- iv. Presence of circuit protective conductors (cpc)**
 - Ensure that the conductors are appropriately installed.
 - Ensure that the connections are secure.
 - Ensure that the cable fixings are adequate.
 - Verify that the conductors are selected in accordance with Table 54.7 of BS 7671 or calculated by using Regulation 543.1.3.

Additional protection

There are two forms of additional protection:

- Additional to basic protection – where cables and accessories are at higher risk of damage due to the environment and location. Examples include cables concealed in a wall where a nail could accidentally be hammered into them or an item of equipment in a bathroom subjected to steam and water. In these types of situations, we provide additional protection by an RCD rated no more than 30 mA.
- Additional to fault protection – where disconnection times cannot be met due to higher than acceptable earth fault loop impedance where it is impractical or impossible to reduce the impedance, we provide supplementary equipotential bonding as additional protection.

(ix) Prevention of mutual detrimental influence

Regulations 132.11 and 515.1 require that the electrical installation and its equipment shall not cause detriment to other electrical and non-electrical installations. Equally, other non-electrical services shall not have a detrimental impact on electrical installations. The inspector is advised to step back and think about other systems when carrying out the inspection – for example, cables under floorboards that touch central heating pipes.

(x–xx) Selection and erection

The remainder of the list deals with the correct selection and erection of devices, labels, and wiring systems where needed. The devices needed include fault protective devices, AFDDs and surge protection devices.

Means of isolation (item x) should be provided as follows.

- **At the origin of the installation** – a main-linked switch or circuit breaker should be provided as a means of isolation and of interrupting the supply on load. For single-phase household and similar supplies that may be operated by unskilled persons, a double-pole device must be used for both TT and TN systems. For a three-phase supply to an installation forming part of a TT system, an isolator must interrupt the line and neutral conductors. In a TN-S or TN-C-S system only the line conductors need be interrupted as the installation has a reliable connection to earth.
- **For every circuit** – other than at the origin of the installation, every circuit or group of circuits that may have to be isolated without interrupting the supply to other circuits should be provided with its own isolating device.
- **For every item of equipment** – all fixed electrical equipment should be provided with a means of switching which can be used for the safety and maintenance of systems, from industrial production equipment to individual items, such as immersion heaters, hand dryers and showers.
- **For every motor** – every fixed electric motor should be provided with a readily accessible and easily operated device to switch off the motor and all associated equipment, including any automatic circuit breaker.
- **For every supply** – all isolators must be labelled or identified, if it is not obvious which circuits they control.

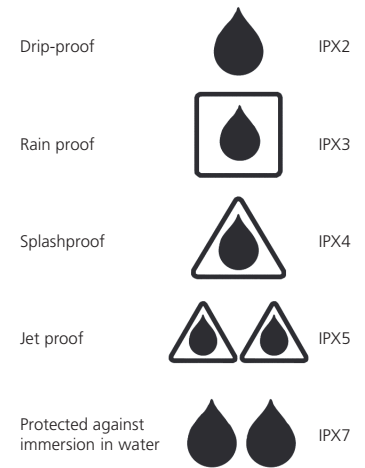

▲ Figure 6.17 Codes and signs used on equipment where water is likely to be present

INDUSTRY TIP

An isolator is a mechanical switching device which, in the open position, complies with the requirements specified for the isolating function. Most isolators are manufactured to switch on/off the supply during no-load conditions. The switching and control devices for the equipment must be used to de-energise the load before the isolator switching mechanism is opened. One of the most common causes of burnt-out terminals and conductor insulation within an isolator is not a loose terminal, as most would suspect, but the fact the isolator is being used as an on-load switch, which the device is not designed to do.

Part of the inspection process is to ensure that any device that is likely to be used as a switch within an installation, is actually rated as a switch. Always check the manufacturer's information regarding the rating of the device for switching.

The inspections checklist (for new installation work)

Amendment 2 of BS 7671 introduced a new type of Electrical Installation Certificate that contains the Schedule of Inspections within it. When completing the schedule of inspections, you should undertake this using the checklist in Appendix 6 of BS 7671.

Here we will look at the schedule of inspections checklist that is specifically for initial verification purposes. If a periodic inspection and test is undertaken, a condition report inspection schedule should be used.

INDUSTRY TIPS

Unlike SELV and PELV, a functional extra-low voltage (FELV) system is not regarded as a protective measure and forms part of ADS.

When completing a schedule of inspection for an Electrical Installation Certificate, boxes must be marked with either a tick for compliance, or as not applicable (n/a). No box should be marked as 'unsatisfactory' and anything found to be unsatisfactory should be corrected before any certification is issued.

Table 6.3 shows how the checklist is laid out and describes what should be considered, including the relevant regulation number from **BS 7671** The IET Wiring Regulations.

▼ Table 6.3 Outline of the schedule of inspections

Item no.	Description	Guidance (any numbers shown indicate regulation numbers or sections from BS 7671)
1.0	Condition of intake equipment	
1.1	Consumer's isolator (where present)	These items should be checked for their levels of basic protection against electric shock and how well they are fixed securely. That they are located for easy access for maintenance or proximity to other services such as gas. Inspectors should also look for signs of damage, tampering and ensure that all tails remain insulated to all terminations.
1.2	Consumer's meter tails	
2.0	Parallel or switched alternative sources of supply	
2.1	Adequate arrangements where a generating set operates as a switched alternative to the public supply	If the installation has a backup (standby) generator, is there a correctly fitted changeover switch in place which ensures that the generator, when on, doesn't power up the supply system? In addition, does the generator system have its own independent earthing system? (551.6)
2.2	Dedicated earthing arrangement independent of the public supply	If the installation is supplied with a form of generator which works with the supply, is there adequate means of ensuring the supply system is not energised if the supply system fails? A common example is where an installation has a photovoltaic (PV) system feeding the installation as well as the supply. In this case, the inverter for the PV will shut down if it detects a supply failure (551.7).
2.3	Presence of adequate arrangements where generator to operate in parallel with the public supply system	
2.4	Correct connection of generator in parallel	
2.5	Compatibility of characteristics of means of generation	
2.6	Means to provide automatic disconnection of generator in the event of loss of public supply system or voltage or frequency deviation beyond declared values	



Item no.	Description	Guidance (any numbers shown indicate regulation numbers or sections from BS 7671)
2.7	Means to prevent connection of generator in the event of loss of public supply system or voltage or frequency deviation beyond declared values	
3.0	Protective measure: automatic disconnection of supply	
3.1	Distributor's earthing arrangement	The Main Earthing Terminal (MET) is correctly connected to the means of earthing depending on the supply earthing arrangement. For example, for a TN-C-S, the earthing conductor is suitably connected to the supply PEN conductor.
3.2	Installation earth electrode (where applicable)	The MET is suitably connected to a correctly selected and erected earth electrode in the case of a TT earthing arrangement.
3.3	Earthing conductor and connections including accessibility	Suitably sized to be buried (TT as Table 54.1) or sized for current capacity (TN Table 54.7). Continuous (if not visible throughout its length it may require testing to confirm this). Connections tight, suitably supported.
3.4	Main protective bonding conductors connections including accessibility	All extraneous parts connected by main protective bonding (MPB) to the main earthing terminal (MET) as (411.3.1.2). Sized correctly (544.1 or Table 54.8), continuous (if not visible throughout its length it may require testing to confirm this). Connected at a suitable point at extraneous parts (within 600 mm of entry or on consumers' side of any valve, stop or meter and before any tee joints). Connections secure and the correct type of clamp used for the external influences (this may be identified by clamp colour coding).
3.5	Provision of safety electrical earthing/bonding labels at all appropriate locations	Suitable labelling 'safety electrical connection; do not remove' at any earth/bonding connection separate from any switchgear (514.13).
3.6	RCDs provided for fault protection	Where an RCD is relied upon as fault protection (disconnection times are not met by a protective device as Z_s values are too high) the RCD is selected in accordance with Table 514.4.9 and 41.5. If RCDs are not relied on for fault protection and are provided for additional protection only, this would be marked as n/a.
3.7	Provisions where automatic disconnection is not feasible	In situations where disconnections times cannot be met, perhaps due to high earth fault loop impedance, and the use of an RCD is not feasible as the continuity of service is important, local supplementary equipotential bonding may be provided in the location where a risk of touch voltages may exist. So, in the event of a fault of longer duration, the risk of shock is reduced by maintaining equal potential between extraneous parts local to the circuit equipment having higher disconnection times.
3.8	FELV – requirements satisfied	Any circuit where the voltage has been reduced to values < 50 V AC for functional reasons, and the requirements of SELV and PELV have not been met, the general requirements for ADS must apply.
3.9	RLV – requirements satisfied	Any circuit supplying equipment at 110 V AC must meet the requirements of Section 418 of BS 7671 including the values of earth fault loop impedance as Table 41.8.
4.0	Basic protection	
4.1	Presence and adequacy of measures to provide basic protection within the installation	
4.1	Insulation of live parts	All conductors should be insulated with material suitable for the intended voltage. The insulation must cover conductors right up to the terminal or connection with no bare conductor showing (416.1).



Item no.	Description	Guidance (any numbers shown indicate regulation numbers or sections from BS 7671)
4.2	Barriers and enclosures	All barriers and enclosures provide adequate protection stopping contact with live parts. This would include checking the correct level of IP protection such as IP2X or IPXXB applied to all surfaces with exception of any accessible top surface which must be IP4X or IPXXD. Live parts must only be accessible by the use of a tool or key. There are some exceptions such as a ceiling rose, but these items must be located in a generally inaccessible location, such as a ceiling where a person requires steps to gain access (416.2).
4.3	Obstacles	These two methods of protecting persons from contact with parts intended to be live are only permitted where they are under effective supervision by skilled persons. Examples of an obstacle include safety railings or fencing which can be removed without the use of a tool or key stopping accidental contact with live parts (417).
4.4	Placing out of reach	
5.0	Protective measures other than ADS	
5.1	SELV	Separated extra-low voltage circuits must be supplied by a suitable device, typically a transformer, which provides suitable separation. In addition, any metallic parts of a SELV system must be separated from earth. An inspection of the transformer type and that cables are segregated from each other would be required (414).
5.2	PELV	Protective extra-low voltage circuits are similar to SELV but in PELV systems, there may not be the separation from earth (414).
5.3	Double insulation i.e. Class II or equivalent equipment and associated circuits	Rarely used in most installations, Class II protection ensures the risk of parts becoming live is minimised by having basic insulation and further level of insulation or reinforced insulation. Where these circuits exist, the system would have to be under effective supervision by skilled persons (412). These may be used where, for example, the length of a circuit would not provide a low enough Z_s to achieve disconnection but the equipment being supplied is entirely Class II.
5.4	Reinforced insulation i.e. Class II or equivalent equipment and associated circuits	
5.5	Non-conducting locations	These two measures, detailed in Section 418 of BS 7671 are very specialised and are not applied in any general electrical installation. They may be used where disconnection of the supply under fault conditions is a bigger danger, such as a medical location, and the risk of electric shock is reduced to a minimum by local equipotential bonding or removed by having walls and floors that do not conduct electricity.
5.6	Earth free local equipotential bonding	
5.7	Electrical separation	The inspector must check that the device providing separation is a transformer to the correct BS standards, such as that for a shaver point. If the separated system is a circuit, perhaps between a transformer and socket outlet, check that the cables are suitably segregated or insulated from other circuits to minimise the risks of a second fault. Commonly found as fixed power supplies for power tools in large plant rooms in order to comply with the requirements for conductive locations with restricted movement (Part 7) (413).
6.0	Additional protection	
6.1	RCDs not exceeding 30 mA as specified	Where additional protection is provided, RCDs in accordance with 415.1 are used so it must be confirmed that the RCDs are rated with a residual current setting no more than 30 mA. The reasons for providing additional protection are covered in Section 8 later in this document. This box is ticked to confirm the rating is correct.
6.2	Supplementary bonding	To confirm, where required, supplementary bonding has been provided. This may include some special locations or situations where disconnection times cannot be met and the use of an RCD for fault protection is not feasible (Part 7 or Section 419).
7.0	Distribution equipment	
7.1	Adequacy of access and working space for items including switchgear	The inspector must be satisfied that all switchgear and control equipment is fully accessible for use and maintainability. The particular requirements of Section 729 may also need to be met. In dwellings, particular sections of the building regulations may also apply.



Item no.	Description	Guidance (any numbers shown indicate regulation numbers or sections from BS 7671)
7.2	Security of fixing	These are all checks to ensure the distribution equipment has not been damaged during erection and that all suitable fire seals (where needed) have been applied. The housing must provide basic protection (see box 4.2) and must provide suitable fire ratings for the intended location (421.1). Any CU or DB installed within a dwelling must have a suitable fire rating such as a metal enclosure (422.1.201).
7.3	Insulation of live parts not damaged during erection	
7.4	Adequacy/security of barriers	
7.5	Suitability of enclosure for IP and fire ratings	
7.6	Enclosure not damaged during erection	
7.7	Presence and effectiveness of obstacles	
7.8	Components are suitable and in accordance with manufacturer's instructions	
7.9	Presence of main switch(es) linked where required	
7.10	Isolators, for every circuit or group of circuits and all items of equipment	Suitable means of isolation provided for an installation and circuits. Devices should be capable of being locked in the off or open position (462.1) and does it operate without obstruction and free of mechanical damage?
7.11	Operation of main switch as a functional check	
7.12	Manual operation of circuit breakers, RCDs and AFDDs to prove functionality	Ensuring the switching action of these devices operates correctly and free of any obstruction.
7.13	Confirmation of integral test button causing RCDs to trip as a functional test	Ensuring the integral test button operates the RCD (note, the device must be energised for the RCD to operate).
7.14	Confirmation that overvoltage protection by SPDs is provided (where applicable)	Where needed, surge protection devices are installed and of the correct type for the location.
7.15	Selection of correct protective devices are correct type and rating	Are the right type of fuses or circuit breakers used? Check for the correct rating and short circuit/breaking capacity. Are they the correct type (gG or gM) of fuse or (B, C or D) circuit breaker for the intended application (411.4 and 432-433).
7.16	Single-pole devices in line conductor only	All single-pole devices, such as fuses or circuit breakers are connected to the line conductor only.
7.17	Protection against mechanical damage where cables enter equipment	Cables entering the enclosure must be provided with suitable mechanical protection such as glands, grommets or edging (522.8.5).
7.18	Protection against electromagnetic effects where cables enter ferromagnetic enclosures	Where conductors pass through metal enclosures, lines should be run with their corresponding neutrals to reduce heating effects caused by induced eddy currents (521.5.1).
7.19	Confirmation that ALL conductor connections, including connections to the busbars, are correctly located in terminals and are tight/secure	Connections must be tight and checked to ensure that good connection to the conductor exists and terminations aren't clamped onto the insulation (526.1).
8.0	Circuits (distribution and final)	
8.1	Identification of conductors	Are all conductors fully identifiable? (514.3.1)
8.2	Conductors are correctly identified by colour, lettering or numbering	Are the correct colour or number systems used so that every circuit conductor can be easily identifiable? (Table 51)
8.3	Cables correctly supported throughout, with protection against abrasion	The inspector must be satisfied that all electrical equipment, cables and containment systems are suitably and securely installed. As an example, does a conduit have adequate saddles which are correctly spaced? (521-522)



Item no.	Description	Guidance (any numbers shown indicate regulation numbers or sections from BS 7671)
8.4	No basic insulation of a conductor visible outside of an enclosure	A thorough inspection of all circuit conductors and cable support/management systems is required to ensure that the requirements of Chapter 52 are met and that no damage has occurred while the installation work has been carried out. Does the containment system have the correct IP ratings where non-sheathed cables are used? (521.10.1 and 526.8)
8.5	Examination of cables for signs of mechanical damage during installation	
8.6	Examination of insulation of live parts, not damaged during erect	
8.7	Non-sheathed cables protected by enclosure in conduit, ducting or trunking	
8.8	Suitability of containment systems (including flexible conduit)	
8.9	Correct temperature rating of cable insulation	
8.10	Adequacy of cables for current-carrying capacity with regard to the type and nature of installation	This is an area that mainly rests with the designer in that the circuits have been correctly designed, taking into consideration all factors such as grouping of circuits, ambient temperatures, installation methods etc. (Section 523).
8.11	Adequacy of overcurrent protective devices: type and fault current rating for fault protection	These areas ensure that the devices selected and installed for protection are suitably selected and installed in terms of type, rating and capacity. They must be suitable for all installation faults including short circuits, earth fault or arcs. In some situations, the function of all these may be in a single device.
8.12	Adequacy of RCDs: type and current rating	
8.13	Adequacy of AFDDs: current rating	
8.14	Presence, adequacy and correct termination of protective conductors	This is to verify that all protective conductors, other than those verified in 3.1, are selected (Chapter 54) and correctly terminated to all equipment as required by 411.3.1.1.
8.15	Coordination between conductors and overload protective devices	The inspector must be satisfied that all conductors are suitably sized for the intended load and voltage drop constraints. The inspector will be reliant on the designer's specification for this but a good level of experience is also required. The inspector must ensure correct coordination exists $I_b \leq I_n \leq I_z$ (523 and Chapter 43). This items links to item 7.8 of this document.
8.16	Wiring systems and cable installation methods/practices with regard to the type and nature of installation and external influences	Are cables installed using suitable containment or management systems or where applicable, clipped direct. The method used must be compatible for the external influences present and the type of cable used (Chapter 52).
8.17	Cables concealed under floors, above ceilings, in walls/partitions, adequately protected against damage	If cables are not in the zones of protection as detailed in 522.6.202, they must be protected by an earthed metallic covering. Also, where cables are concealed in a wall and are not provided with additional protection by an RCD as below (8.18 item iii and iv), they must comply with this section. Cables in floors or above ceilings must comply with 522.6.201.
8.18	Provision of additional protection by RCDs having a residual operating current not exceeding 30 mA for:	
	All socket outlets of rating 32 A or less, unless an exception is permitted	All socket outlets rated up to 32 A must have additional protection by RCDs or the designer has carried out a suitable risk assessment. The risk assessment should verify that the organisation using the socket outlets has adequately trained staff, equipment registers and carries out regular checks and tests on equipment used on the socket outlets and that the equipment is suitable for its environment and use (411.3.3 and Appendix 2).
	Supplies for mobile equipment not exceeding 32 A rating for use outdoors	RCDs in accordance with 415.1 must be provided for all mobile equipment used outdoors not exceeding 32 A (411.3.3).



Item no.	Description	Guidance (any numbers shown indicate regulation numbers or sections from BS 7671)
	Cables concealed in walls at a depth of less than 50 mm	Cables concealed in a wall and within the zones of protection given in 522.6.202 must have RCD protection in accordance with 415.1 or have further impact protection as 522.6.204.
	Cables concealed in walls/partitions having metal parts regardless of depth	Cables in partitions having metal parts other than screws, nails or similar, must have RCD protection in accordance with 415.1 or comply with 522.6.204 as stated in 522.6.203.
	Final circuits supplying luminaires within domestic premises	In dwellings, all circuits that supply a luminaire of any type must have additional protection by a 30 mA RCD.
8.19	Provision of fire barriers and sealing arrangements	The inspector must be satisfied that all electrical equipment provides suitable protection to stop the spread of fire/thermal effects in accordance with Chapter 42. It must also be verified that elements of the building structure affected by the installation, such as trunking passing through floors, are adequately sealed (527.2).
8.20	Segregation/separation of Band I and Band II circuits	The inspector must be satisfied that any electrical circuits operating at ELV are adequately segregated from low voltage circuits unless the ELV circuits are insulated to the low voltage standards. An example may be a doorbell circuit using bell wire must be segregated from lighting circuits. In addition, all electrical equipment, cables etc. is suitably distanced from any services that may affect the installation. An example may be hot water pipes near cables. If spacing is unavoidable, the electrical parts must be suited for the effect of the services. See Section 528.
8.21	Cables segregated/separated from non-electrical services	Cables are adequately spaced or protected from the effects of other services, such as damage that could occur from heating pipes (Section 528).
8.22	Termination of cables at enclosures	
	Connection under no undue strain	The correct type of connection has been used and that the connection is not under strain due to the conductor not being properly supported (522.8.5).
	No basic insulation visible outside enclosure	Sheathed cables must have the sheathing present up to the enclosure with no core insulation showing outside of that enclosure (526.8).
	Connection of live conductors adequately enclosed	That the enclosure used to house the connection is of the correct type and provides sufficient protection (526.5).
	Adequately connected at point of entry to enclosure by glands, bushes etc.	Ensuring the cable is securely held as it enters the enclosure (where needed) and that the cable is not placed under any strain as a result of the cable being secure (or not) (522.8.5).
8.23	Suitability of circuit accessories for external influences	The inspector must be satisfied that all electrical equipment is suitably selected and erected for all external influences it may be subjected to. A complete list of external influences can be seen in Appendix 5.
8.24	Circuit accessories not damaged, securely fixed, correctly connected, suitable for external influences	A very general check that all accessories on the circuit(s) are securely fixed or supported, not damaged and have been correctly selected for their environment and any dangers that could be reasonably expected due to their location.
8.25	Single-pole devices for switching or protection in line conductors only	The inspector must be satisfied that all single-pole devices control the line conductor of the circuit and not the neutral. This includes circuit breakers, fuses, switches etc. (132.14.1 and 530.3.2).
8.26	Cables and conductors correctly connected, enclosed and with no undue mechanical strain	All cable connections must be durable and of the correct type for the application (526).
8.27	Adequacy of connections, including cpc's, within accessories and at fixed and stationary equipment	Ensuring that the correct type of connection used for the circuit cable or conductor, including live and protective conductors. Examples include ensuring terminals are suitable for stranded conductors etc. (526.6).



Item no.	Description	Guidance (any numbers shown indicate regulation numbers or sections from BS 7671)
9.0	Isolation and switching	
9.1	Isolators	
	Presence and location of appropriate devices	Every installation shall have means of isolating the whole installation (main switch) and each individual circuit (circuit breakers etc.).
	Capable of being secured in the off position	These devices must be capable of being secured in the off position by means of padlocking, being in a lockable space or similar (Section 462).
	Correct operation verified (functional check)	
	The installation, circuit or part thereof that will be isolated clearly identified by location and/or durable marking	
9.2	Switching for mechanical maintenance	
	Presence of appropriate devices	Any item of equipment that requires mechanical maintenance (non-electrical works such as cleaning filters, tensioning belts etc.) must have an appropriate switch located where it can be supervised during those maintenance tasks. If it cannot be supervised, then the switch must be capable of being secured in the off position (464, 537.3).
	Acceptable location	
	Capable of being secured in the off position	
	Correct operation verified (functional check)	
9.3	Emergency switching off	
	Presence of appropriate devices	Certain items of equipment may require a means of stopping the equipment in the event of an emergency such as a rotating machine. Stop buttons are an example and an inspection would determine that they are the correct type (latchable or key latched as an example) and located in a readily accessible position (465.1, 537.3).
	Readily accessible for operation	
	Correct operation verified (functional check)	
	Firefighter's switch	Certain equipment operating at high voltages requires control using a firefighter's switch located and in accordance with (537.4). Statutory Regulations may also require firefighter's switches in accordance with Chapter 53 such as petrol filling stations.
9.4	Functional switching or control	
	Presence of appropriate devices	All current-using equipment must have a switching device which controls the equipment or several items of equipment. An example would be a light switch (463.1, 537.3.1).
	Correct operation verified (functional check)	
	Control of parts of the installation and current-using equipment as intended	
10.0	Current-using equipment (permanently connected)	
10.1	Suitability of equipment in terms of IP and fire ratings	Equipment must be suitable for all the external influences it will be subjected to. This would include equipment being mechanically sound and having suitable IP protection such as IPX4 for equipment installed outdoors where splashes of water from all directions are likely (Appendix 5).
10.2	Enclosure not damaged/deteriorated during installation so as to impair safety	
10.3	Suitability for the environment and external influences	
10.4	Security of fixing	All equipment must be secure, not just for mass but for the likely effects during function, such as vibration.
10.5	Cable entry holes in ceilings above luminaires, sized or sealed so as to restrict the spread of fire	Ensuring that the integrity of any fire compartments between floors are maintained so a fire within a luminaire will not spread to other floors or compartments in a building (527.2).



Item no.	Description	Guidance (any numbers shown indicate regulation numbers or sections from BS 7671)
10.6	Provision of undervoltage protection, where specified	Equipment, such as motors, must have an overload device set correctly for that equipment so if the machine jams, the overload device functions (Chapter 43). Undervoltage protection to motors may be provided by a contactor such as a DOL starter. This stops the equipment from suddenly re-starting should a power loss occur followed by sudden restoration of the power (445).
10.7	Provision of overload protection, where specified	
10.8	Provision of overload and/or undervoltage protection e.g. for rotating machines, if required	
10.9	Correct selection and installation of luminaires fitted	All luminaires within the installation have been correctly selected and erected to be suitable for their location, use and connection method to the final circuit (559.3).
10.10	Installed to minimise the build-up of heat and restrict the spread of fire	Equipment must be suitable for the material it is mounted on and suitable when a risk of fire exists due to the stored or processed material as Chapter 42. It should be verified that the equipment is suitable by mark or specification. An example may be a luminaire mounted on wood should carry a mark such as a D within a triangle showing it has a limited surface temperature (see Table 55.3).
10.11	Adequacy of working space/ accessibility to equipment	All equipment, including connections, must be accessible for maintenance, inspection and have sufficient space for safe operation (132.12 and 513.1).
11.0	Identification and notices	
11.1	Presence of RCD six-monthly test notice; where required	A range of labels, notices, schedules and charts are needed throughout an installation. These are all detailed in: 514.9 Diagrams and documents 514.10 to 17 Warning notices and general notices. Samples of the notices, including dimensions for each, can be found in Appendix 11 of BS 7671.
11.2	AFDD six-monthly test notice; where required	
11.3	Presence of diagrams, charts or schedules at or near each distribution board, where required	
11.4	Presence of alternative supply warning notice at or near:	
	The origin	
	The meter position, if remote from origin	
	The distribution board to which the alternative/additional sources are connected	
	All points of isolation of ALL sources of supply	
11.5	Presence of next inspection recommendation label	
11.6	Presence of other required labelling	
11.7	Presence of labels to indicate the purpose of switchgear and protective devices	
11.8	Warning notice posted in situation where live parts cannot be isolated by the operation of a single device	
11.9	The circuit or part thereof to be disconnected clearly identified by location and/or durable marking	
11.10	The installation, circuit or part thereof to be disconnected clearly identified by location and/or durable marking	



Item no.	Description	Guidance (any numbers shown indicate regulation numbers or sections from BS 7671)
12.0	Location(s) containing a bath or shower	
12.1	Additional protection for all low voltage (LV) circuits by RCD not exceeding 30 mA	The requirements of Section 701 of BS 7671 are to be verified including checking the items listed such as 30 mA protection to all LV circuits Equipment suitable for zones Supplementary bonding (where required) Adequate distances have been applied relative to the zones.
12.2	Where used as a protective measure, requirements for SELV or PELV met	
12.3	Shaver supply units comply with BS EN 61558-2-5 formerly BS 3535	
12.4	Presence of supplementary bonding conductors, unless not required by BS 7671	
12.5	Low voltage (e.g. 230 V) socket outlets sited at least 2.5 m from zone 1	
12.6	Suitability of equipment for external influences for installed location in terms of IP rating	
12.7	Suitability of accessories and control gear etc. for a particular zone	
12.8	Suitability of current-using equipment for particular position within the location	
13.0	Other special installations	
13.1	Where the installation includes special installations or locations relating to sections of Part 7, additional inspection items should be added to the checklist.	Inspection of the equipment should be made to verify that it is suitable for the location and complies with the relevant section of Part 7 of BS 7671. The inspector should complete their own additional schedule for each relevant special installation or location.
13.2	List all other special installations or locations present, if any. (Record separately the results of particular inspections applied)	
14.0	Prosumer's low voltage electrical installation(s)	
14.1	Where the installation includes additional requirements and recommendations relating to Chapter 82, additional inspection items should be added to the checklist	Chapter 82 of BS 7671 provides additional requirements for any electrical installations that produce, store, or supply electricity back into the grid. These installations are known as prosumer electrical installations (PEI).

TESTING

Testing follows inspection and is intended to support the inspection. In order to test effectively, inspectors need to be methodical, checking everything. It is important to note that the initial verification testing of an installation is probably the only time a full test is undertaken as future periodic testing will likely only be sampling. For that reason, comprehensive and reliable test results must be obtained during initial verification, ensuring all points are tested.

In addition, inspectors must consider their test instruments and the sequence of testing.

Appropriate tests and sequence for electrical installations

The tests which need to be carried out during initial verification are listed below. Some of the tests will not be applicable to all electrical installations.

Regulation section 643 – prescribed tests

The sequence of dead tests must be undertaken in the sequence shown below, as the result of one test, such as insulation resistance, relies on the reliable results of another, such as continuity.

The tests shown in **red** are rarely undertaken as those of 643.4 can normally be verified by inspection only and 643.5 is only applicable where the protective measure is a non-conducting location, which is a very rare installation. 643.11 is rarely actually undertaken if the installation has been designed correctly and this can be verified by design. This test will be briefly explained.

Dead tests

643.2 Continuity of conductors, to include:

- protective conductors, such as cpc, main and supplementary bonding conductors
- continuity of ring-final circuit conductors

643.3 Insulation resistance

643.4.1 Protection by SELV

643.4.2 Protection by PELV

643.4.3 Protection by electrical separation

643.4.5 Basic protection by a barrier or enclosure provided during erection

643.5 Insulation resistance/impedance of floors and walls

643.6 Polarity

643.7.2 Earth electrode resistance (if applicable and using an earth electrode resistance test instrument).

Live tests

643.7 Protection by automatic disconnection of supply, to include:

- earth electrode resistance (if applicable and using an earth fault loop impedance test instrument)
- earth fault loop impedance
- prospective fault current

643.8 Additional protection

643.9 Check of phase sequence

643.10 Functional testing

643.11 Verification of volt drop.

Because the tests for 643.5 are very rarely undertaken, they are not described in this book.

HEALTH AND SAFETY

Always take extreme care when testing live. Some instruments, such as RCD testers and earth fault loop impedance testers, use high currents in order to test and this means the earthing is live for short durations.

Test instruments

There are many different styles and manufacturers of test instruments. Many instruments are multifunction testers but some are still standalone testers. Whichever type you use, the preparation and safety requirements are almost the same. Efficient and safe testing relies on instruments being accurate, compliant with safety requirements and prepared for the test to be undertaken.

Setting up your test meter

Here we will look at each type of tester. Remember, these could be functions as part of a multifunction tester.

Low-resistance ohmmeter

The tests carried out with this meter are:

- continuity of protective conductors, including main and supplementary equipotential bonding
- continuity of ring-final circuit conductors
- polarity.

The meter setting is in ohms (Ω), as shown in Figure 6.18.

The test meter should be capable of supplying a no-load voltage of between 4 V and 24 V (AC or DC) and a short-circuit current of not less than 200 mA. The measuring range should span 0.2 Ω to 2 Ω , with a resolution of at least 0.01 Ω for digital instruments.

Note that general-purpose multi-meters are not capable of supplying these voltage and current parameters.

Insulation resistance tester

The tests carried out with this meter are:

- insulation resistance testing
- separation of circuits, including
 - SELV or PELV
 - electrical separation.

The meter setting is in megohms ($M\Omega$), as shown in Figure 6.19. The test meter must be capable of supplying an output test voltage of 250 V DC, 500 V DC or 1000 V DC, subject to the circuit to be tested. The readings can range from 0.00 $M\Omega$ to a maximum of 200 $M\Omega$, or with some instruments up to 999 $M\Omega$. Always consult the manufacturer's instructions to know the maximum range of your instrument.

Earth fault loop impedance tester

The tests carried out with this meter are:

- earth fault loop impedance
- prospective fault current
- earth fault loop impedance of earth electrodes.

Figure 6.20 shows the meter set to Loop – 20 Ω scale, which is usually used for TN systems and some TT systems. An earth fault loop impedance tester with a resolution of 0.01 Ω should be adequate for circuits rated up



▲ Figure 6.18 Continuity testing – the left dial is set to the Ω scale and the right dial is set at 20 Ω



▲ Figure 6.19 Insulation resistance testing – the left dial is set to 500 V and the right dial is set at 2000 $M\Omega$

to 50 A. Instruments conforming to **BS EN 61557-3** will fulfil the above requirements.

Earth fault loop impedance instruments may also offer additional facilities for deriving prospective fault current. The basic measuring principle is generally the same as for earth fault loop impedance testers.

Figure 6.21 shows the correct settings for deriving the prospective fault current. Prospective fault current is measured in kA.

The readings must be compared with the rated short-circuit capacity of the protective devices.

Residual current device (RCD) tester

The tests carried out with this meter are:

- additional protection
- residual current device operation.

RCDs must be checked to ensure that they are operating in accordance with the manufacturer's intended time limits. These results are given in milliseconds (ms). Methods and appropriate maximum trip times can be found in Section 11 of the IET On-Site Guide.

Figure 6.22 shows just one example of a typical setting for this test.

Earth electrode testing, polarity testing, phase rotation testing, functional testing and verification of voltage drop will be addressed as we progress through the test sequence.

Safe and correct use of instruments

When using test instruments, safety can be achieved by ensuring that the following points are followed.

Steps to follow when using instruments

1 Checking that the instruments being used conform to the appropriate British Standard safety specifications

The basic instrument standard is **BS EN 61557** 'Electrical safety in low-voltage distribution systems up to 1000 V AC and 1500 V DC. Equipment for testing, measuring or monitoring of protective measures.'

2 Instrument accuracy

Instrument accuracy of 5% is usually adequate for testing. This can be verified by checking the instrument against known values which are called check boards or check cards.

3 Calibration

- Calibration must be carried out on each piece of test equipment in accordance with the manufacturer's recommendations.
- Regular checking may be carried out using known references.
- Usually, annual calibration suffices, unless the instrument is subject to excessive mechanical stresses.



▲ Figure 6.20 Earth fault loop impedance testing – this example shows the dial set at Loop – 20 Ω . Loop 200 Ω and 2000 Ω may need to be used when testing TT systems



▲ Figure 6.21 Prospective fault current testing – this example shows the dial set at PSC – 20 kA



▲ Figure 6.22 RCD testing – this example shows the dial set at RCD – $\times \frac{1}{2}$ with the 30 mA setting displayed in the LCD

HEALTH AND SAFETY

Check that the fuses in the instrument leads are the correct type and rating, as specified by the manufacturer.

HEALTH AND SAFETY

The GS38 information listed below relates to the design and maintenance of approved electrical test equipment for use by electricians.

Probes should have:

- finger barriers
- an exposed metal tip not exceeding 4 mm; however, it is strongly recommended that this is reduced to 2 mm or less
- fuse, or fuses, with a low current rating (usually not exceeding 500 mA), or a current-limiting resistor and a fuse.

Leads should be:

- adequately insulated
- colour coded
- flexible and of sufficient capacity
- protected against mechanical damage
- long enough
- sealed into the body of the voltage detector and should not have accessible exposed conductors, other than the probe tips.

4 Understanding the equipment

You should understand the equipment to be used and its ranges. It is important, also, to understand the characteristics of the installation where the test instrument will be used.

5 Selecting and using the appropriate scales and settings

It is essential that the correct scale and setting are selected for an instrument in a particular testing situation. As a vast range of instruments exists, always read the manufacturer's instructions before using an unfamiliar instrument. Further things to consider are the following.

- When a meter displays a number 1 in the left of the display, it usually means that the instrument reading is over the range selected.
- For continuity testing, the lowest ohms scale must be selected as values are usually low.
- Remember that the values shown while insulation resistance testing is taking place are in megohms (millions of ohms).
- Many instruments feature a 'no-trip' function when testing earth fault loop impedance. This should only be used where an RCD is in the circuit. In all other cases, the 'high' setting should be used as this is much more accurate.
- Manufacturer's instructions must be followed when selecting the method of prospective fault current testing, including the test lead arrangement and voltage capabilities.

6 Checking test leads

Check that test leads, including any probes or clips, are in good order, are clean and have no cracked or broken insulation.

Where appropriate, the requirements of the Health and Safety Executive Guidance Note **GS38** should be observed for test leads. Figure 6.24 shows a test instrument with a range of test leads, probes and clips. These leads can be used for different tests.

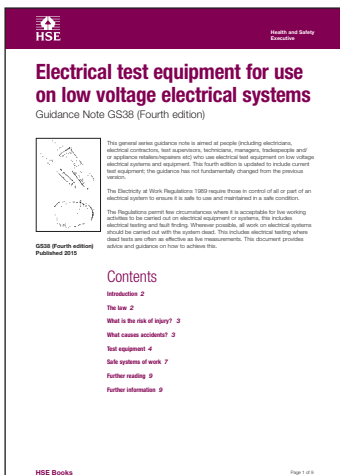

▲ Figure 6.23 The first page of HSE GS38



▲ Figure 6.24 Multi-function test instrument showing a range of leads and probes (image courtesy of Megger)

The tests

In order to obtain the most accurate results, the testing must be performed in particular ways to minimise factors that can affect the results, such as parallel paths.

Remember that the first tests are 'dead' tests and therefore it is assumed that safe isolation has been carried out. The state of the supply in terms of isolation for the 'live' tests will be explained for each test.

Continuity of conductors

▼ Table 6.4 Continuity of conductors

Test	Continuity of earthing conductor
Reasons for the test	This test must be carried out to ensure that the earthing conductor is not broken; it should connect the main earthing terminal to the means of earthing. This test is not required if the conductor can be seen throughout its length.
Meter to be used	Low-resistance ohmmeter
Additional equipment needed	Long wander lead depending on the length of the earthing conductor
Meter preparation	Check operation by open lead test then closed lead test. Null or zero any leads used for the test.
Preparation	Disconnect the earthing conductor at the MET to remove any possible parallel paths.
Health and safety considerations	Installation securely isolated. If a long wander lead is used, this may be a trip hazard for others. However, it is unlikely that this would be required as most earthing conductors are only 1 or 2 m in length.
Method	Test the conductor resistance from one end to the other, including any clamps that may be used.
Expected results	This depends on the length and csa of the conductor. If a clamp is used to connect the conductor to the means of earthing, the result may be slightly higher than that expected for the conductor alone.
Verifying results	Determine the expected resistance (R) using the IET On-site Guide Table I1 or Table B1 of GN3 (reproduced here as Table 6.5).  Find the resistance, in milli-ohms per metre ($m\Omega/m$), for the cable csa and calculate: $R = \frac{m\Omega/m \times \text{length}}{1000} \Omega$ So, as an example, a 16 mm^2 conductor has a resistance in $m\Omega/m$ of 1.15 and a length of 3 m so: $R = \frac{1.15 \times 3}{1000} = 0.003 \Omega$ But as most meters cannot measure below 0.01Ω , the value displayed is likely to be either 0.01 or 0.00. If a clamp is used to connect the conductor to the supplier's cable sheath or an earth electrode, the resistance will be slightly higher due to the clamp.

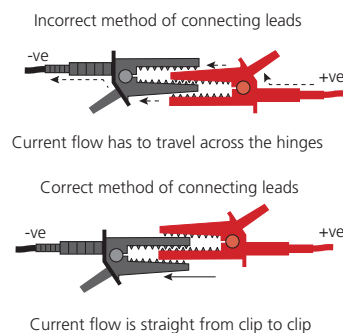

▲ Figure 6.25 Always connect leads correctly

HEALTH AND SAFETY

If the building is occupied, a full risk assessment should be carried out before using wander leads of any great length.

INDUSTRY TIP

If the readings you are getting with a low resistance ohmmeter will not settle and start to increase, reverse the test leads.

▼ Table 6.5 Resistance values for cables (information extracted from Table B1 of Guidance Note 3)

Conductor csa mm^2	Copper conductor resistance $m\Omega/m$
4	4.61
10	1.83
16	1.15

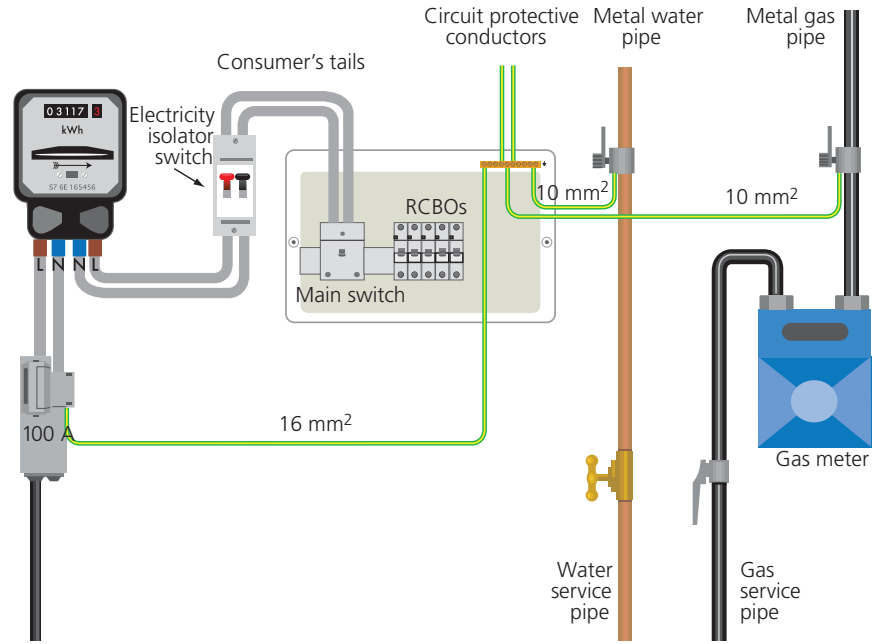

▲ Figure 6.26 Typical single-phase installation showing the earthing conductor (16 mm²) and two Main Protective Bonding Conductors (10 mm²) connected to the gas and water service pipes

▼ Table 6.6 Continuity of main protective bonding conductors

Test	Continuity of main protective bonding conductors
Reasons for the test	To ensure that the conductors are continuous with no breaks. To confirm that the resistance is low, which will ensure less voltage is lost across the conductor keeping equipotential (equal-potential) between extraneous parts and the installation MET.
Meter to be used	Low-resistance ohmmeter
Additional equipment needed	Long wander lead depending on the length of the conductor
Meter preparation	Check operation by open lead test then closed lead test. Null or zero any leads used for the test.
Circuit preparation	Disconnect the bonding conductor at the MET to remove any possible parallel paths.
Health and safety considerations	It is essential that the installation is securely isolated before any bonding is removed. If there is any issue on the supply PEN conductor, there will be a voltage difference between the installation earth and true earth. If bonding is disconnected at any point, then the person disconnecting will become a bridge with different voltages across their body, leading to a potentially dangerous electric shock. If a long wander lead is used, this may be a trip hazard for others.
Method	Test the conductor resistance from one end to the other, including any clamps that may be used, by testing onto the pipework, etc. depending on the extraneous part being tested.
Expected results	Determine the expected resistance (R) using the IET On-Site Guide Table I1 or Table B1 of GN3.  Find the resistance, in milli-ohms per metre (mΩ/m), for the cable csa and calculate: $R = \frac{\text{m}\Omega/\text{m} \times \text{length}}{1000} \Omega$

Test	Continuity of main protective bonding conductors
	So, as an example, a 10 mm ² conductor has a resistance of 1.83 mΩ/m and a length of 12 m so: $R = \frac{1.83 \times 12}{1000} = 0.02 \Omega$
What is recorded	No results are recorded but on the EIC, you tick the box confirming the continuity has been verified.
Verifying results	GN3 states the resistance of the clamp should be in the order of 0.05 Ω, so if the conductor in the example above was tested with a probe connection on the pipework, the reading expected should not exceed: 0.02 Ω + 0.05 Ω = 0.07 Ω Generally, values below 0.1 Ω are considered suitable.
Something to consider	If the bonding was not disconnected, parallel paths would exist. Imagine, in the diagram above for a single-phase installation, that there was a gas-fired water boiler connecting the gas and water pipes together. If the bonding of one conductor was measured without any disconnection, the path measured would also be through the other bonding conductor in parallel. This would have the effect of almost halving the result.

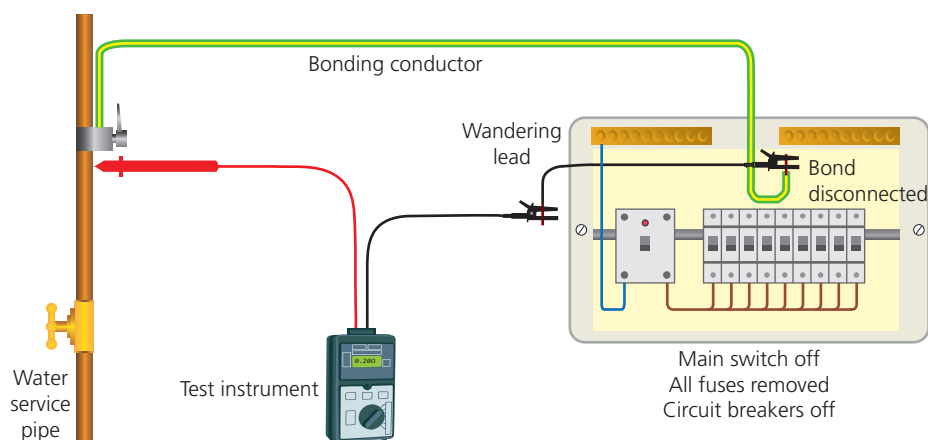

▲ Figure 6.27 Testing main protective bonding

▼ Table 6.7 Continuity of cpc for radial circuits

Test	Continuity of cpc for radial circuits
Reasons for the test	This test is carried out to ensure that a cpc is present and effectively connected to all points in the circuit, including all switches, sockets, luminaires and outlets.
Meter to be used	Low-resistance ohmmeter
Additional equipment needed	$R_1 + R_2$ method – temporary link lead, which could be a short length of cable or a pre-made test lead with crocodile clips on each end. R_2 method – long wander lead. When testing socket outlets, a plug adaptor enabling testing at the front tubes is a useful item to have as this test can also confirm polarity. When testing at the terminals of a socket outlet there is a danger of testing at a conductor by colour and not the labelled terminal, meaning cross-polarities would not be revealed.



INDUSTRY TIP

Every point in the circuit must be tested to confirm a cpc is present and connected as this is probably the only time this will be confirmed.

INDUSTRY TIP

Table I1 in the IET On-Site Guide is a very useful table when inspecting and testing but remember that the resistance values given in the table are based on a temperature of 20°C. So, if you are using the table for design purposes, you must always factor for operating temperatures. Because we generally test at temperatures around 20°C, we do not need to factor in temperature change.

Additionally, if testing is undertaken in temperatures different from 20°C, factors from Table I2 can be used to adjust the values determined, using Table I1 to suit test values at the stated temperatures.

Test	Continuity of cpc for radial circuits
Meter preparation	Check operation by open lead test then closed lead test. Null or zero all leads used for the test.
Circuit preparation	Every terminal should be accessible. If the wiring system is metallic, such as trunking, this can give parallel earth paths, so disconnecting the cpc from the earth terminal will reduce the effects of the parallel paths. If the entire installation is isolated (and only if), disconnect the main protective bonding from the MET to reduce parallel paths through extraneous parts, such as metallic service pipes.
Health and safety considerations	The circuit must be isolated. Ideally, the whole distribution board should be isolated. If a long wander lead is used, this may be a trip hazard for others.
Method	$R_1 + R_2$ method: <ul style="list-style-type: none"> Place a temporary link between line and cpc at the distribution board. At every point in the circuit, test between line and cpc. For three-phase circuits, treat each line conductor as a separate circuit. Ensure two-way switching arrangements are operated during the test at lighting points to ensure all line conductors are continuous. By operating any switch on the circuit during the test and observing the readings, open and close can also confirm polarity of the circuit. If testing L-E is not possible due to connected electronic devices such as PIR sensors, test the N-E as an alternative method of verifying continuity. R_2 method: <ul style="list-style-type: none"> Connect the wander lead to the cpc at the distribution board. At each point in the circuit, test between the connected cpc and the wander lead.
Expected results	The results depend on the csa and length of the line and cpc conductors in the case of the $R_1 + R_2$ method or just the cpc length and csa for the R_2 method.  Determine the expected resistance ($R_1 + R_2$) using the IET On-Site Guide Table I1 or Table B1 of GN3. Find the resistance, in milli-ohms per metre (mΩ/m), for the cable csa and calculate: $R_1 + R_2 = \frac{\text{m}\Omega/\text{m} \times \text{length}}{1000} \Omega$ So, as an example, circuit is wired using a 2.5 mm ² line conductor with a 1.5 mm ² cpc which has a resistance of 19.51 mΩ/m from Table I1 or B1, and the circuit length is 24 m so: $R_1 + R_2 = \frac{19.51 \times 24}{1000} = 0.47 \Omega$
What is recorded	The highest reading taken during the test is entered onto the schedule of test results in either the $R_1 + R_2$ column or the R_2 column, depending on the method used. If polarity was also confirmed, the polarity column can be ticked.
Verifying results	At this point, there is nothing to verify as long as the readings are as expected. If an $R_1 + R_2$ was recorded, this can be used later to determine and verify earth fault loop impedance values.



Test	Continuity of cpc for radial circuits
<p>Something to consider</p>	<p>The use of the R_2 method is not encouraged during an initial verification but mixing the methods is probably the most effective way to test.</p> <p>For several reasons explained below, it is encouraged to obtain $R_1 + R_2$ values for the circuit but if you are in a room and want to verify a metal switch or metallic parts and accessories of a system are connected to earth, you could use a wander lead (or just the test leads depending on distance) to check the cpc links the light and switch or metallic parts, etc. without the need to open accessories to get to the line conductor.</p> <p>The reasons why obtaining $R_1 + R_2$ is better are:</p> <ul style="list-style-type: none"> ● Having $R_1 + R_2$ results will make earth fault loop testing much easier later in the sequence ● When periodic testing is undertaken in the future, $R_1 + R_2$ results are good benchmark figures to have. When you consider earth fault loop impedance is the sum of the $R_1 + R_2$ and the external loop impedance (Z_e), the Z_e can vary depending on system loading, voltage variations and modifications to the supply system. This in turn will affect Z_s but the $R_1 + R_2$ should never change (unless of course someone alters the circuit but that should be tested afterwards). So if someone later gets higher Z_s values, they can measure $R_1 + R_2$ to see if the reason for this is circuit deterioration. ● By measuring $R_1 + R_2$ and successfully checking switching opens the circuit, polarity is also confirmed.

INDUSTRY TIP

Remember:

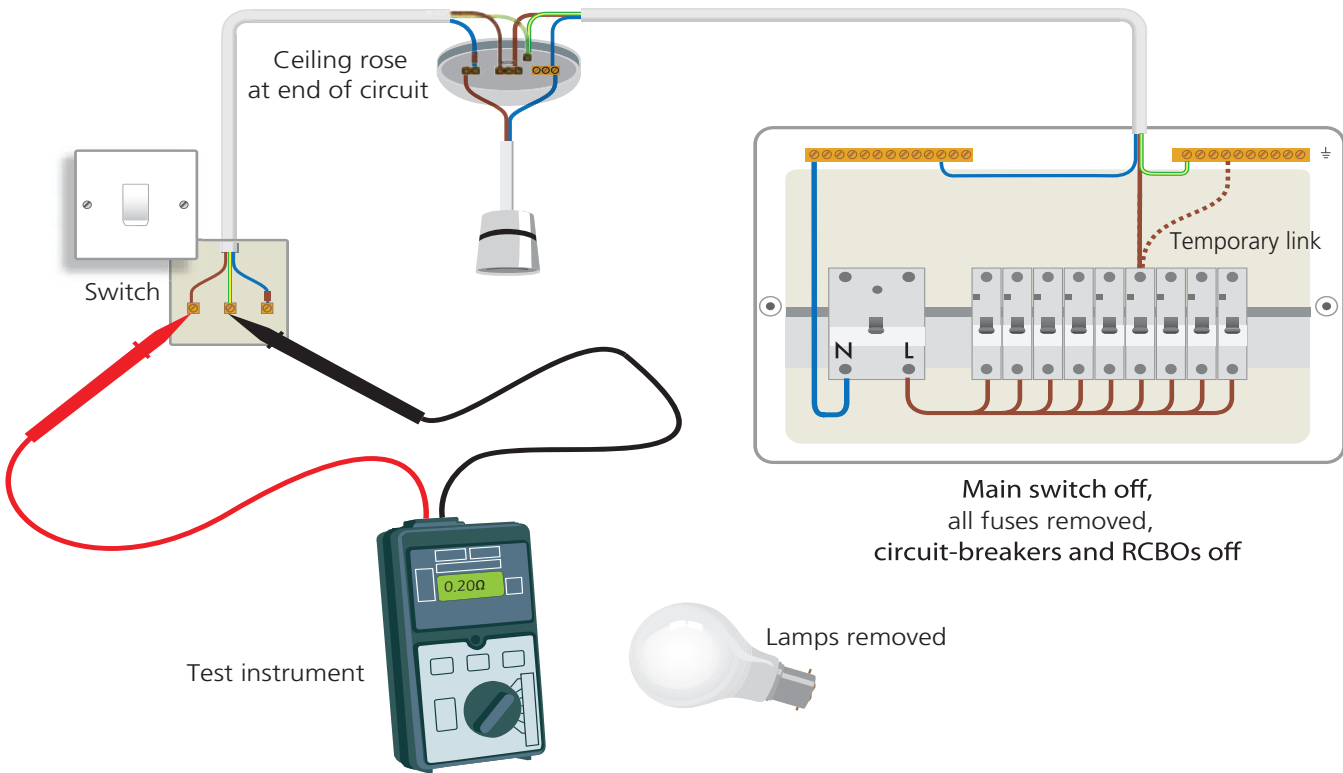
$$Z_s = Z_e + R_1 + R_2$$



▲ Figure 6.28 Continuity testing at a light switch using the $R_1 + R_2$ test method

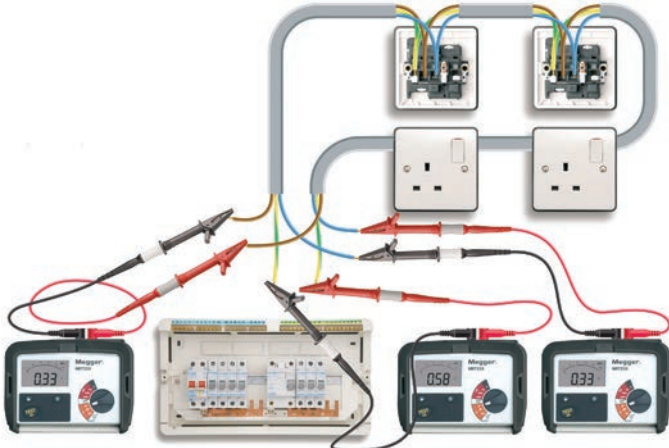

▼ Table 6.8 Continuity of ring-final circuits

Test	Continuity of ring-final circuits
Reasons for the test	To confirm that the ring is wired as a ring with no breaks, interconnections or incorrectly wired spurs.
Meter to be used	Low-resistance ohmmeter
Additional equipment needed	Plug adaptor to check the socket outlets at the front tubes. Connector block or similar to form the figure 8 test.
Meter preparation	Check operation by open lead test then closed lead test. Null or zero all leads used for the test.
Circuit preparation	The lines, neutrals and circuit protective conductors for the circuit must be disconnected from the distribution board in order to carry out this test. It is best to leave socket outlets connected and in place.
Health and safety considerations	The circuit must be isolated.
Method	<p>This test is undertaken in three steps.</p> <p>Step 1 – Test end-to-end resistance of the ring at the distribution board between the disconnected conductors and note down the readings as:</p> <ul style="list-style-type: none"> ● Line to line: r_1 ● Neutral to neutral: r_n ● cpc to cpc: r_2 <p>The readings taken should be the same if all conductors have the same csa and are correctly wired. If the cpc has a reduced csa, the reading r_2 will be proportionately higher. If the live conductors are 2.5 mm^2 and the cpc is 1.5 mm^2, the resistance r_2 should be $1.67 \times r_1$ as the csa of the line conductor is 67% bigger than the cpc.</p>
	<p style="text-align: center;">IMPROVE YOUR MATHS </p> <p>The difference in resistance is proportional to the difference in csa for conductors. If you divide 2.5 by 1.5 you get 1.67, meaning that a 2.5 mm^2 conductor is 67% bigger than a 1.5 mm^2 conductor. If you multiply the resistance of the 2.5 conductor by 1.67 (increasing by 67%) you get the resistance of the 1.5 conductor. So what are the resistance differences for 4/2.5 mm^2 conductors?</p>
	
	▲ Figure 6.29a Step 1 of the ring-final circuit testing
	Step 2 – Interconnect, using a connector, the line of one leg of the ring to the neutral of the other leg, then the remaining line and neutral together. This forms a figure 8 configuration. It is referred to as figure 8 owing to the way the conductors are configured during the test.

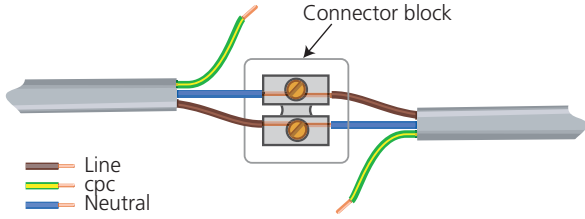
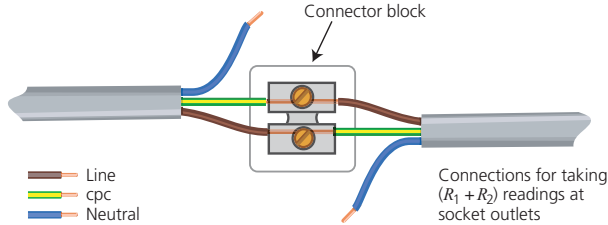

Test	Continuity of ring-final circuits
	<p>At every socket outlet on the circuit, test between line and neutral. The readings should be consistently similar at every socket outlet, providing they are connected into the ring and not spurs. See expected results below for the expected values.</p>  <p>▲ Figure 6.29b Step 2 of the ring-final circuit testing</p>
	<p>Step 3 – Interconnect, using a connector, lines and circuit protective conductors to form the figure 8. At every socket outlet on the circuit, test between line and cpc. The readings should be consistently similar at every socket outlet, providing they are connected into the ring and not spurs. See expected results below for the expected values.</p> <p>Ensure that all conductors are reconnected at the distribution board before moving on to any other test, and confirm the connections are tight!</p>  <p>▲ Figure 6.29c Step 3 of the ring-final circuit testing</p>
<p>Expected results</p> <div style="background-color: #ffff00; padding: 5px; text-align: center; font-weight: bold; margin-bottom: 10px;">INDUSTRY TIP</div> <p>The reason that the line loop (r_1), when added to the neutral or cpc loop (r_n or r_2), is divided by 4 is because there are four paths in parallel being tested. This quarters the overall reading.</p> <p>Another way to look at it is to say that the cross-sectional area is effectively doubled for the line (meaning half the resistance), as well as for the neutral or cpc (again half the resistance), thus overall the resistance is divided by 4.</p>	 <p>Step 1</p> <p>The results expected are dependent on the conductor csa and the length of the ring loop. These can be checked against calculated values using Table I1 of the IET On-Site Guide.</p> <p>Example: A ring-final circuit is wired using 2.5/1.5 mm² conductors and the results of step 1 were:</p> <ul style="list-style-type: none"> ● $r_1 = 0.8 \Omega$ ● $r_n = 0.8 \Omega$ ● $r_2 = 1.34 \Omega$ <p>Step 2</p> <p>The results obtained at each socket outlet should be very close to the results calculated as below:</p> $\frac{r_1 + r_n}{4}$ <p>So, using the example figures, the readings for step 2 at each socket outlet should be:</p> $\frac{0.8 + 0.8}{4} = 0.4 \Omega$ <p>Step 3</p> <p>The results obtained at each socket outlet should be very close to the results calculated as below:</p> $\frac{r_1 + r_2}{4}$ <p>So, using the example figures, the readings for step 3 at each socket outlet should be:</p> $\frac{0.8 + 1.34}{4} = 0.54 \Omega$

Test	Continuity of ring-final circuits
	If any result is higher than expected, once all the results are gathered, check to see if the socket outlet where higher results were obtained is wired as a spur.
What is recorded	The results of step 1 are recorded on the schedule of test results as r_1 , r_2 and r_n . The highest reading obtained during step 3 of the test between line and cpc is recorded as the circuit $R_1 + R_2$. If all results were as expected, the circuit polarity can be confirmed by ticking the polarity column.
Verifying results	Providing the results are consistent and as expected, the ring can be verified as correct and polarity of all the sockets can also be confirmed, providing the tests at the sockets were carried out using a plug adaptor.
Something to consider	<p>If results were not as expected, ensure that you note down all readings before trying to chase a fault. By having all readings, you are in a better position to judge what the fault is.</p> <p>For example, if we consider the expected results from the examples above but the results at one socket outlet were actually:</p> <p>Line to neutral (step 2) – open circuit (no reading) Line to cpc (step 3) – 0.54 Ω</p> <p>We would, without getting the results of step 3, start making an assumption that the socket was either disconnected or the line or neutral was an open circuit. By getting the result of step 3, a better judgement can be made.</p> <p>Looking at all the results, it could be concluded that the line and cpc were wrongly connected at the socket, giving an incorrect polarity.</p> <p>As we get a reading between line and cpc as expected, if the connections at the back of the socket were the wrong way round, we would get the same result as if they were correct.</p> <p>However, we got an open circuit between line and neutral because we were actually testing neutral to cpc. It is possible that the neutral has become disconnected, but if that was the case, we would not have got an r_n reading at step 1.</p> <p>Because of the possibility of faults, it is a good idea to produce a table to note down the results at each socket for each step. Some schedules of tests results produced by industry organisations already have these printed on the back.</p>

▼ Table 6.9 Insulation resistance

Test	Insulation resistance (general lighting and power circuits)
Reasons for the test	<p>To ensure that the insulation throughout the installation is undamaged and suitable for the intended voltage. Damaged or defective insulation will lead to short circuits or, even worse, earth faults and therefore potential electric shock.</p> <p>On a busy construction site with many trades, the risk of damage to a cable is high. Someone may drill a wall not realising there are cables there and damage the insulation; this would go unnoticed if this test wasn't properly carried out. Equally, cable insulation could become damaged when cables are drawn into conduits, etc.</p>
Meter to be used	<p>Insulation resistance tester set to the voltage applicable to the circuit being tested and as stated in Table 64 of BS 7671.</p> <p>SELV or PELV circuits – 250 V DC Circuits that operate up to 500 V or FELV circuits – 500 V DC Circuits that operate over 500 V – 1000 V DC.</p> <p>In certain circumstances, such as where circuits contain surge protection devices (SPDs), the test voltage for a 230 V circuit may be reduced to 250 V. Higher voltages will cause the SPD to operate as it is seen as a voltage surge and this will affect results. Some socket outlets have SPDs fitted. Always check manufacturer's documentation regarding voltage tolerances.</p> <p>Because the voltages used for this test are high, test current should be low to reduce the risk of electrocution. Typically, test currents are 1 mA.</p>

INDUSTRY TIP

Higher voltages than those the system operates at are used for this test to put the insulation under duress. Think of insulation resistance testing as pressure testing a water pipe to see if it leaks. Voltage is pressure too so if the insulation can handle 500 V without leaking, it will be able to cope with 230 V.



Test	Insulation resistance (general lighting and power circuits)
Additional equipment needed	Connectors if equipment requires bridging out.
Meter preparation	Check the meter functions correctly by applying an open circuit test (leads apart) and a closed circuit test (leads together). As this test uses voltages exceeding 120 V DC, the instrument and leads must be GS38 compliant.
Circuit preparation	Remove or disconnect (isolate) any loads as they may be damaged by the high voltages and give incorrect test values. Electronic switching devices, such as dimmer switches or PIR sensors, must be disconnected and bridged out using connector block or similar. RCBOs protecting the circuit may also give suspect results and may also need isolating from this test. Switches should be in the closed (on) position to allow readings throughout the entire circuit and contactors may need to be bridged, otherwise testing will need to be done separately for the section of circuit beyond the contactor. As much as possible, with exception of the above-mentioned equipment, the installation should be in a complete state with all accessories connected and covers on, and all bonding in place and connected. Ideally, the entire installation should be tested as one, so all circuit breakers and fuses must be in place and closed.
Health and safety considerations	The high voltages used for this test are a risk, not only to the inspector, but also anyone else in the area. GS38 must be observed with regards to test leads and instruments. In addition, ensure that when you test a circuit, make sure the button is released on the tester before moving the probes. When certain cables are tested, such as SWA or MICC cables, they can act like capacitors storing a charge. This charge could be released into someone if they came into contact with the conductors, causing electrocution. By releasing the test button on the circuit, most test instruments will also discharge any energy stored by the cables. Circuits may also have capacitors installed which could also release dangerous charges introduced by the test. When testing an installation, the supply must be isolated.
Method	At the distribution board, test between the following: Single-phase: <ul style="list-style-type: none"> ● Line to neutral (live to live) ● Line to earth (live to earth) ● Neutral to earth (live to earth) Three-phase: <ul style="list-style-type: none"> ● L₁ to L₂ (live to live) ● L₁ to L₃ (live to live) ● L₂ to L₃ (live to live) ● L₁ to N (live to live) ● L₂ to N (live to live) ● L₃ to N (live to live) ● L₁ to E (live to earth) ● L₂ to E (live to earth) ● L₃ to E (live to earth) ● N to E (live to earth) In situations where it is not reasonably practical to disconnect or isolate equipment, test between live and earth only, with all live conductors linked together. This will maintain an equal voltage across any load, minimising the risk of damage, but ideally, this should not apply to an initial verification unless discrete sections of the circuits were fully tested before equipment was connected and the live to earth test was a final check.

INDUSTRY TIP

Many socket outlets now include USB points and these can give incorrect values when tested. Always refer to the manufacturer's documentation when testing circuits including these types of socket outlet.

INDUSTRY TIP

Note that the description for insulation resistance testing uses the term earth and not cpc. When testing to earth, this should include all earthed points.

KEY TERM

Not reasonably practical: In this context, refers to something located in such a position that expensive or unavailable specialist equipment is needed to isolate it.

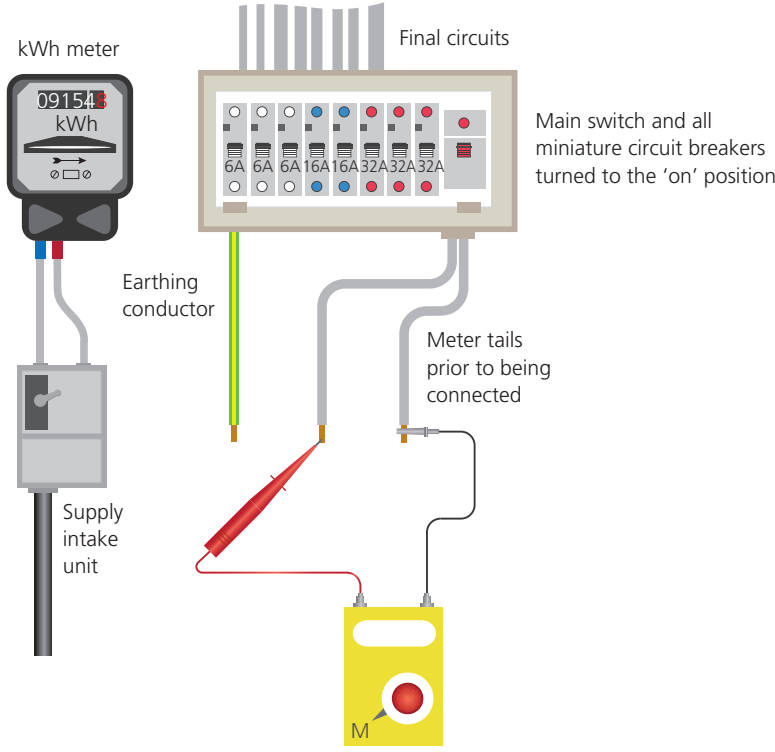

Test	Insulation resistance (general lighting and power circuits)
	<p>It is however reasonable to carry out this test when testing existing circuits during a Periodic Inspection and Test.</p> <p>Remember to operate any switching arrangements, such as two-way switches while testing to ensure all parts of a circuit are put under test.</p> <p>Following the test, remove any links or bridges and reconnect anything removed for the test.</p>  <p>▲ Figure 6.30 Line to neutral test being carried out</p>
<p>What is recorded</p>	<p>The lowest of the live to live tests in the L-L column and the lowest of the live to earth tests in the L-E column.</p> <p>When testing an entire installation, it is good practice to record one result per column and indicate that this covers all circuits. If a result is entered for every circuit, it would be assumed that all circuits were tested individually.</p> <p>The value recorded is dependent on the maximum value the instrument can read. Some instruments can read up to 999 MΩ, so the value recorded would be > 999. Other instruments can read up to 200 MΩ, so the value recorded would be > 200.</p> <p>If a reading value was obtained that was within the instrument range, then the lowest reading is recorded.</p>
<p>Expected results</p>	<p>All results should be as high as possible and, ideally, above the value that the instrument can read.</p> <p>As a rule, if a value below 2 MΩ is recorded for an entire installation, each circuit should be tested to ensure that the cause isn't one single circuit at fault.</p> <p>Results, such as 0.03 MΩ (30 000 Ω), could indicate something has been left connected, such as a neon indicator on a switch.</p>



Test	Insulation resistance (general lighting and power circuits)												
Verifying results	Table 64 of BS 7671 gives minimum values of insulation resistance as follows: <table border="1" style="margin-left: 20px;"> <thead> <tr> <th>Circuit nominal voltage</th> <th>Test voltage</th> <th>Minimum value</th> </tr> </thead> <tbody> <tr> <td>SELV or PELV</td> <td>250 V</td> <td>0.5 MΩ</td> </tr> <tr> <td>Up to and including 500 V (except SELV and PELV)</td> <td>500 V</td> <td>1.0 MΩ</td> </tr> <tr> <td>Above 500 V</td> <td>1000 V</td> <td>1.0 MΩ</td> </tr> </tbody> </table>	Circuit nominal voltage	Test voltage	Minimum value	SELV or PELV	250 V	0.5 MΩ	Up to and including 500 V (except SELV and PELV)	500 V	1.0 MΩ	Above 500 V	1000 V	1.0 MΩ
Circuit nominal voltage	Test voltage	Minimum value											
SELV or PELV	250 V	0.5 MΩ											
Up to and including 500 V (except SELV and PELV)	500 V	1.0 MΩ											
Above 500 V	1000 V	1.0 MΩ											
Something to consider	<p>There are some factors that can affect insulation reading in an otherwise healthy circuit.</p> <p>When testing an entire installation, the overall value could be lower than expected because all the circuits under test are in parallel and, as we know from our science knowledge, the more resistances we have in parallel, the lower the overall value will be.</p> <p>For example, if three individual circuits were tested between line and neutral and the results obtained were:</p> <ul style="list-style-type: none"> ● Circuit 1 – 20 MΩ ● Circuit 2 – 20 MΩ ● Circuit 3 – 50 MΩ <p>The overall resistance if tested together would be:</p> $\frac{1}{R_{total}} = \frac{1}{20} + \frac{1}{20} + \frac{1}{50} = 0.12 \text{ therefore } R_{total} = 8.33 \text{ M}\Omega$ <p>These calculations can be performed on a calculator using the x^{-1} feature. Try this: [20] [x^{-1}] [+] [20] [x^{-1}] [+] [50] [x^{-1}] [=] [x^{-1}] [=] and the answer displayed should be 8.333.</p> <p>Always remember the final x^{-1} or you will not get the desired result!</p>												

INDUSTRY TIP

Remember the golden rule with parallel resistances: the overall resistance must be less than the lowest resistance.

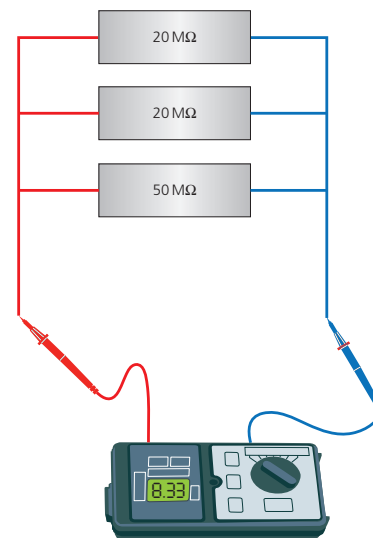

▲ Figure 6.31 The effects of testing parallel resistances

▼ Table 6.10 Separation of circuits

Test	Separation of circuits such as SELV, PELV or electrical separation
Reasons for the test	<p>To ensure circuits that rely on electrical separation are reliably separated from the source circuit and any other parts of the installation.</p> <p>This test is rarely carried out as it can mainly be verified by inspection. By checking that the secondary circuit is physically not in contact with any other circuit or earthed parts, separation can be confirmed. If, however, the secondary circuits share a containment system with other circuits, this test will be required.</p>
Meter to be used	Insulation-resistance tester set to 500 V DC
Additional equipment needed	None
Meter preparation	<p>Check the meter functions correctly by applying an open circuit test (leads apart) and a closed circuit test (leads together).</p> <p>As this test uses voltages exceeding 120 V DC, the instrument and leads must be GS38 compliant.</p>
Circuit preparation	<p>The supply of the primary source circuit must be isolated.</p> <p>Disconnect the transformer providing electrical separation and link the live conductors of the primary circuit together, then link the live conductors of the secondary circuit together.</p> <p>Ensure no loads are connected to the secondary circuit.</p>
Health and safety considerations	The high voltages used for this test are a risk, not only to the inspector, but also anyone else in the area. GS38 must be observed with regards to test leads and instruments.
What is recorded	There is no provision to record these results, so a remark can be made in the remarks column, giving the lowest results.
Expected results	Any result below 1 MΩ is not acceptable and separation is not adequate.

▼ Table 6.11 Polarity

Test	Polarity
Reasons for the test	To ensure: <ul style="list-style-type: none"> ● single-pole devices and switches are installed in the line conductor ● ES lampholders have their centre contact connected to the line conductor ● all accessories are correctly connected ● the supply polarity is correct.
Meter to be used	Low-resistance ohmmeter for circuit polarity Approved voltage indicator (AVI) for the supply polarity
Additional equipment needed	Temporary link lead for circuit polarity
Meter preparation	For circuit polarity, preparation is the same as undertaking an $R_1 + R_2$ test as is the testing procedure, so the information below will focus on the supply polarity test. The AVI should be tested for function on a known supply or proving unit.
Health and safety considerations	As this is a live test, care is needed, and the instrument must comply with GS38.
Method	For single-phase supplies, test: <ul style="list-style-type: none"> ● line to neutral ● line to earth ● neutral to earth. For three-phase supplies, test: <ul style="list-style-type: none"> ● L_1 to L_2 ● L_2 to L_3 ● L_2 to N ● L_3 to N ● L_1 to E ● L_2 to E ● L_3 to E ● N to E ● L_1 to L_3 ● L_1 to N
What is recorded	If the results are as expected, the polarity box on the EIC can be ticked as acceptable.
Expected results	For single-phase supplies: <ul style="list-style-type: none"> ● line to neutral – 230 V ● line to earth – 230 V ● neutral to earth – 0 V For three-phase supplies: <ul style="list-style-type: none"> ● L_1 to L_2 – 400 V ● L_1 to L_3 – 400 V ● L_2 to L_3 – 400 V ● L_1 to N – 230 V ● L_2 to N – 230 V ● L_3 to N – 230 V ● L_1 to E – 230 V ● L_2 to E – 230 V ● L_3 to E – 230 V ● N to E – 0 V
Further tests	Once the main tests are complete and functional checks are carried out, a live polarity indicator, such as those for socket outlets, can be used to check the correct function of a socket.

HEALTH AND SAFETY

Never assume the supply polarity is correct.

HEALTH AND SAFETY

Never undertake, in any circumstances, a live test that isn't necessary, where you expose yourself to live terminals. Using an approved voltage indicator (AVI) to confirm polarity of an accessory isn't necessary as we can prove polarity safely using a low-resistance ohmmeter on a dead circuit. There is, however, no alternative way to test a supply.

At this point in the testing sequence, the main dead tests are done and the installation is safe to energise to carry out live tests, unless the installation is TT and relies on an earth electrode as the means of earthing. Before we continue with the testing methods, it is a good idea to revise earth fault paths and why they are so important to test.

Methods of determining earth fault loop paths

There are three types of system earthing arrangements to consider:

- TN-S
- TN-C-S
- TT.

There are three methods of determining the external earth fault loop impedance (Z_e).

- Measurement: by testing at the origin of the installation – this is the most common and accurate method used.
- Enquiry: such as by contacting the electricity distributor, who will usually quote the maximum possible Z_e value in accordance with the Electricity Safety, Quality and Continuity Regulations 2002; you will require permission to use this system.
- Calculation: this is the most complex method and can only be used if the designer knows all of the relevant impedances and resistances of the system to be tested.

TN-S system and earth fault loop impedance

This section concentrates on the TN-S system. TN-S systems may be three-phase or single-phase.

Three-phase supply for a TN-S system

The three-phase supply for a TN-S installation is shown in Figure 6.32. The electricity distributor will supply the consumer with an earth, which is separated throughout the system but connected to the neutral at the centre point of the supply transformer.

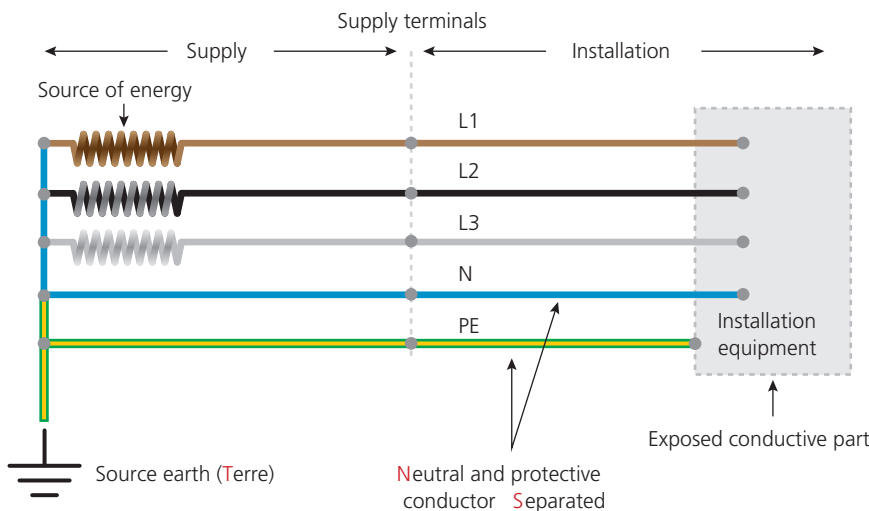

▲ Figure 6.32 Diagram of a three-phase supply for a TN-S installation

Single-phase supply for a TN-S system

This is typical of a domestic (or similar) installation. In both single- and three-phase supplies, a TN-S system will normally use the sheath of the supplier's cable as a means of earthing the installation. From this sheath, the earthing conductor will connect to the installation's main earthing terminal (MET). An enquiry to an electricity distributor regarding the characteristics of a domestic supply will result in them declaring the external earth fault loop impedance (Z_e) = 0.8Ω , which is the maximum for separate earth supplies in TN-S systems. The Z_e value in practice will normally be considerably less than 0.8Ω .

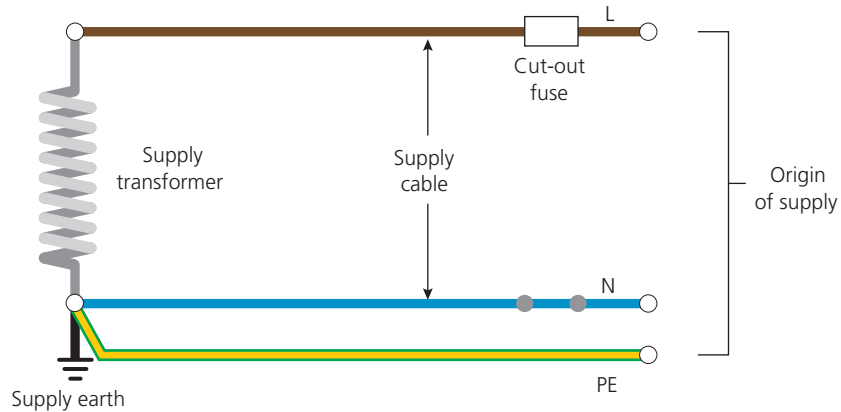

▲ Figure 6.33 Simple representation for a TN-S system

TN-C-S system and earth fault loop impedance

This section concentrates on the TN-C-S system (PME). There are three methods of determining the earth fault loop impedance (Z_e).

- Measurement: by testing at the origin of the installation – this is the most common and accurate method used.
- Enquiry: such as by contacting the electricity distributor, who will usually quote the maximum possible Z_e value in accordance with the Electricity Safety, Quality and Continuity Regulations.
- Calculation: this is the most complex method and can only be used if the designer knows all of the relevant impedances and resistances of the system to be tested.

Three-phase supply for a TN-C-S system

The three-phase supply for a TN-C-S installation is shown in Figure 6.34.

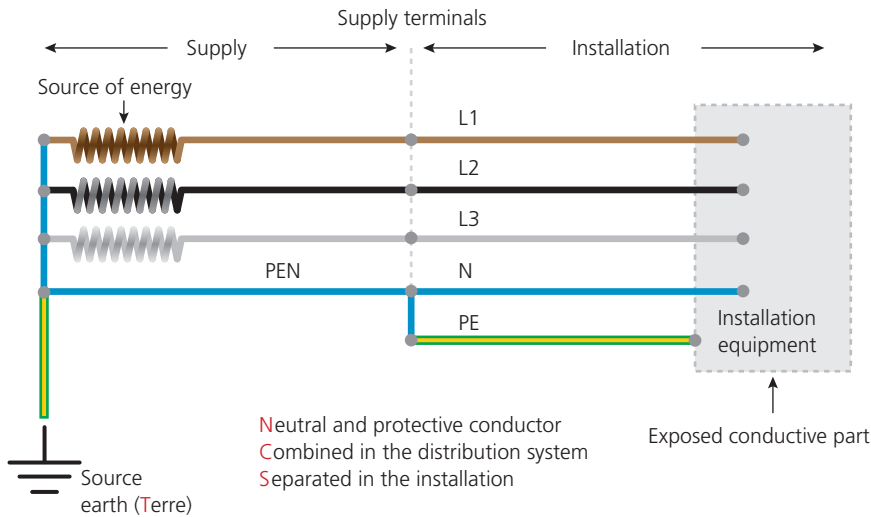

▲ Figure 6.34 A three-phase supply for a TN-C-S installation

Single-phase TN-C-S system

In both three- and single-phase cases the electrical distributor will supply the consumer with an earth which is connected to the neutral at the origin of the installation. The neutral is connected to the centre point of the supply transformer. As the neutral now doubles as an earth, it is referred to as a protective earthed neutral (PEN) conductor. In the UK the most common earthing arrangement is now TN-C-S, or PME.

New supplies will almost always be PME to provide for a TN-C-S system.

An enquiry to an electricity distributor for the characteristics of a domestic supply will result in them declaring the external earth fault loop impedance (Z_e) = 0.35 Ω , the maximum for PME supplies (TN-C-S systems). The Z_e value in practice will normally be considerably less than 0.35 Ω .

Protective multiple earthing is a system where multiple earth electrodes are installed to provide an alternative path to the star point of a substation transformer. As the PEN conductor is both a live conductor and earth, if this conductor becomes part of an open circuit in the supply, earthed parts of the installation may become live as current tries to find a path back to the substation. This situation is known as neutral current diversion.

Remember, if current flows into a circuit, the same current flows back on the neutral. If this neutral becomes open, that current needs an alternative path and, as the earthing of the installation is connected to the supplier's neutral, this may provide the path needed.

If the supply contains multiple earth electrodes, this risk is reduced as the electrodes should provide a more suitable return path.

TT system and earth fault loop impedance

A TT system is a system in which the electrical distributor does not supply the consumer with an earth. This may be because they can't guarantee the continuity of a protective conductor, such as in the case of a low-voltage supply to a

building by means of an overhead line which could deteriorate, break or become disconnected during adverse weather conditions.

TT systems may also be used on construction sites, caravan parks, marinas and many other locations. This is because the Electricity Safety, Quality and Continuity Regulations will not permit the connection of PME supplies to certain locations. So, the supplier does not give an earth in these situations and it is up to the consumer to provide an earth using an earth electrode.

Generators may also use TT-type systems in order to provide an alternative, reliable earth path. If a generator is installed for standby purposes, and the power is lost, the generator starts up. This generator must have an independent earth as the supplier may be working on the supply system.

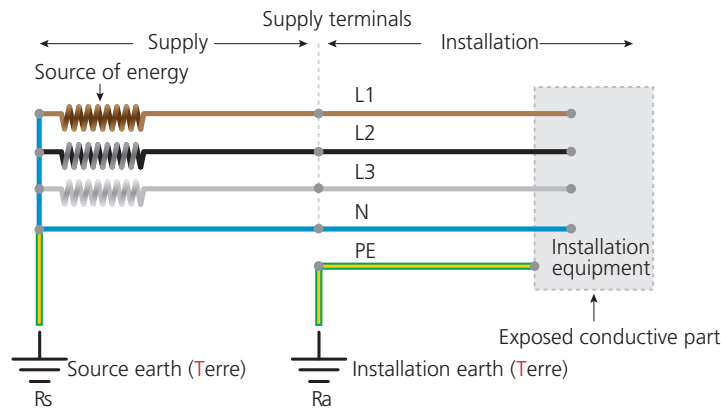

▲ Figure 6.35 A three-phase supply for a TT installation

▼ Table 6.12 Earth electrode resistance testing

Test	Earth electrode resistance testing
Reasons for the test	<p>To ensure that the earth electrode has a reliable connection to the ground and therefore earth.</p> <p>By testing using an earth fault loop impedance tester, the test verifies that the installation earth electrode has a suitable contact with the ground and the ground provides a suitably low resistance to form an earth fault loop path.</p> <p>When carrying out this test this way, the method is exactly the same as if the installation were a TN system, so the method of testing is the same as Z_e which follows this test in this section.</p> <p>If testing this way, results are recorded and verified as described below in this test.</p> <p>The earth electrode resistance tester method tests the resistance of the ground soil around the installation electrode to establish the ground conditions are suitable to dissipate any faults into the ground, allowing disconnection to occur.</p>
Meter to be used	<p>Earth electrode resistance tester</p> <p>Earth fault impedance tester (for test method, see Z_e)</p>
Additional equipment needed	Wet towels if the electrode is surrounded by a hard surface!
Meter preparation	Earth electrode test meter sets are specialised test instruments with their unique test LEDs and electrodes. Always read the manufacturer's instructions relating to the lead connections.

KEY TERM

Dissipate: Providing the ground resistance around the electrode is suitable and the supplier's transformer is connected to the ground, sufficient current will be drawn to and into earth to disconnect a protective device.

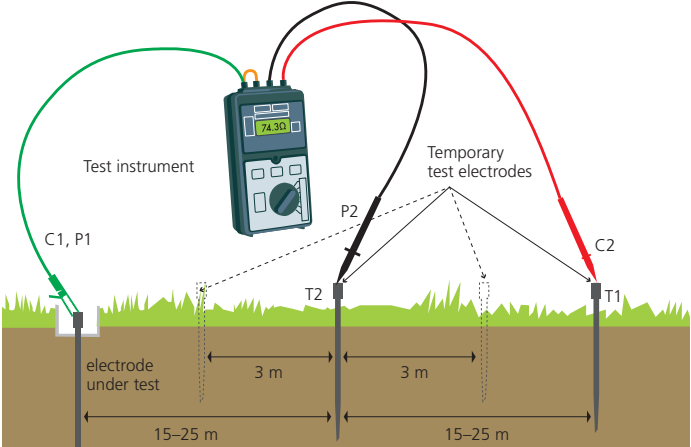

Test	Earth electrode resistance testing	
Circuit preparation	Isolate the installation from the supply. Disconnect the earthing conductor going to the electrode from the installation MET to remove potential parallel paths which will affect readings.	
Health and safety considerations	This test is carried out in a large open area, so consider all the risks associated with the location, such as moving cars in a car park potentially hitting you.	
Method	This test looks complicated but, in reality, is very easy to perform. The overall distance between the electrode under test and T3 (shown in Figure 6.36 as 30–50 m) is normally approximately ten times the length of the earth electrode under test but, in reality, the distance may be governed by the location. Set out the instrument as shown in Figure 6.36, with the test electrode T2 mid-way between the electrode under test and T3. Take reading 1 of 3. Move T2 10% of the overall distance (shown as 3 m) either nearer to T3 or to the earth electrode. Take reading 2 of 3. Move T2 to a position in the opposite direction, 10% of the overall distance from the mid-way point. Take reading 3 of 3. Ensure that the earthing conductor is reconnected following this test.	
	 <p>▲ Figure 6.36 Typical earth electrode test using a three-or-four terminal tester (not to scale)</p>	
What is recorded	The average of the three readings. As an example, if the results of the three readings were: <ul style="list-style-type: none"> • Reading 1 – 71 Ω • Reading 2 – 73 Ω • Reading 3 – 69 Ω The average would be: $\frac{71 + 73 + 69}{3} = 71 \Omega$ So 71 Ω would be recorded on the EIC as the installation earth electrode resistance (R_A). If the test was undertaken using an earth fault loop impedance tester using the Z_e method, and the installation was single-phase, the reading obtained would be recorded as Z_e (not R_A) as the loop was measured, not the electrode resistance.	

INDUSTRY TIP

The wet towel reference is not a joke. If an earth electrode was completely surrounded by a hard surface, such as a car park, the test electrodes could not be placed into the ground so instead, place them on wet towels and the test can be undertaken. This is absolutely true!

INDUSTRY TIP

There are other methods of undertaking this test such as using an instrument having a current clamp test coil. The test is carried out in a similar way to the electrode tester but current flow is measured using a clamp around the earthing conductor.

IMPROVE YOUR MATHS

Remember, an average is found by adding all the values together and dividing by the number of values.



Earth electrode resistance testing	
	If the installation was three-phase, the highest of the three readings from the loop impedance tester would be recorded as Z_e .
Expected results	<p>For the ground resistance around the earth electrode, when using an earth electrode resistance tester, to be regarded as suitable, the three readings should not change by more than 5% of the recorded average reading, so:</p> <p>+5% of $71 \Omega = 74.6 \Omega$ and $-5\% \text{ of } 71 = 67.5 \Omega$</p> <p>And as all the readings were inside of the tolerance of $67.5\text{--}74.5$, the ground is regarded as stable.</p> <p>If the test was undertaken using a loop impedance tester and a reading exceeding 200Ω was recorded, the earth fault loop is not considered reliable enough so a test of earth electrode resistance would be needed, using an earth electrode tester to test the reliability of the soil for dissipation.</p>
Verifying results	<p>The results are verified in conjunction with the device protecting the installation, which is normally an RCD.</p> <p>The value of R_A or Z_e recorded, when multiplied by the RCD residual current setting, in amperes (not mA), must not exceed 50 (V). Ohm's law in other words.</p> <p>To simplify this and transposing Ohm's law, if we found that the installation had a 100 mA (0.1 A) RCD as the main switch then:</p> $\frac{50 \text{ V}}{0.1 \text{ A}} = 500 \Omega$ <p>So as long as the recorded value of R_A or Z_e was less than 500Ω, this is acceptable.</p> <p>Tables 4.15 and 53.1 of BS 7671 have done the calculations and give maximum values acceptable depending on the RCD rating. Note the range of RCDs available, such as 20 A (or 20 000 mA).</p>
Something to consider	Soil resistance changes with weather and seasons. If you record a good earth electrode resistance in the summer and the conditions are dry, the resistance is not likely to get any worse. If, however, you get a borderline reading in the winter in wet conditions, it isn't likely to be suitable in the summer, so improvement is needed.

▼ Table 6.13 Earth fault loop impedance

Earth fault loop impedance (Z_e and Z_s)	
Reasons for the test	<p>To ensure disconnection times are met by the circuit protective device.</p> <p>The total earth fault loop impedance (EFLI) (Z_s) has a direct effect on the disconnection times under earth fault conditions as a very low EFLI will, under fault conditions, induce a high fault current, which in turn will disconnect devices quickly.</p> <p>In addition, if it can be proven that a fuse or circuit breaker disconnects in the required time, not an RCD or an RCD part of an RCBO, then it can be assumed that a circuit will also disconnect quickly enough under short-circuit conditions to protect the circuit.</p>
Meter to be used	Loop impedance tester

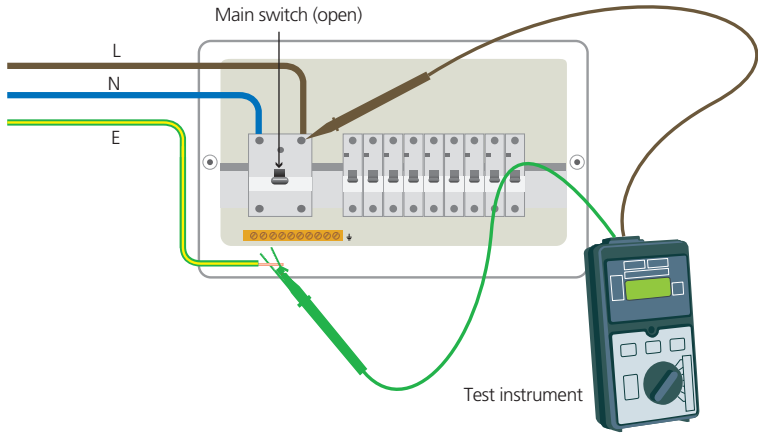

Test	Earth fault loop impedance (Z_e and Z_s)
Meter preparation	Many test instruments have two settings for this test: No-trip or low – this setting is used where the system under test has an RCD on the supply side of the test point. It tests using a lower current but for a much longer duration. The low current should not trip an RCD. This test will require three test leads to be connected to the instrument. High – this setting uses a much higher test current and if there is no concern regarding tripping RCDs, this test setting should be used as the test is far quicker and arguably, produces more accurate results. Generally, this test only requires two leads connected to the test instrument. Always check the manufacturer's instructions regarding settings and lead connections.
Circuit preparation	When testing the external earth fault loop impedance (Z_e) the installation must be isolated and the earthing conductor disconnected from the MET. If testing at accessories on final circuits, unless adaptors are used allowing safe testing such as plug adaptors, the circuit must be isolated to allow dismantling to expose the live terminals, restoration of the supply to test, then isolation to reassemble. When testing the total earth fault loop impedance (Z_s) live, always ensure bonding is fully connected.
Health and safety considerations	Never unnecessarily expose yourself to live terminals. Realistically, all final circuit values of Z_s can be calculated, meaning the only live test needed is to establish a reliable Z_e . As this is a live test, instruments and leads must comply with GS38.
Method	When testing the installation Z_e , test at the distribution board closest to the origin of the installation and on the supply side of the main switch. For single-phase installations, test: <ul style="list-style-type: none"> ● line to earth. For three-phase installations, test: <ul style="list-style-type: none"> ● L_1 to earth ● L_2 to earth ● L_3 to earth. When determining circuit Z_s values, calculate: $Z_s = Z_e + (R_1 + R_2)$ Or if testing Z_s directly at a point because there is no other reasonable way to do it, test between line and cpc, observing the health and safety requirements. 

▲ Figure 6.37 Earth fault loop impedance tester testing Z_e

HEALTH AND SAFETY

It is strongly recommended in IET Guidance Note 3 Appendix E that checks are made to determine the risk of diverted neutral currents.

Diverted neutral current can arise from other electrical installations where shared metallic services exist or other extraneous parts.

It is always worth testing for this before disconnecting any earthing or bonding such as the earthing conductor.

Using a clamp-on ammeter on the earthing conductor may detect diverted neutral current. Other safety checks are detailed in Appendix E of Guidance Note 3.

HEALTH AND SAFETY

Do you remember what the Electricity at Work Regulations states about working live? Only do so if there is no other reasonable alternative. When it comes to testing earth fault loop impedance on a final circuit, there is a reasonable alternative: add $R_1 + R_2$ to the Z_e !

KEY TERM

Distribution circuit: Unlike a final circuit, which supplies current-using equipment, a distribution circuit is the supply to a distribution board.

Test	Earth fault loop impedance (Z_e and Z_s)
What is recorded	<p>The value obtained for single-phase installations or the highest of the three-phase values is recorded on the EIC as Z_e.</p> <p>On the schedule of test results for the first distribution board of the supply (usually referred to as the consumer unit), the Z_e is also recorded as the Z_s at the distribution board.</p> <p>For circuit Z_s values, these are recorded on the schedule of test results in the Z_s column. Three-phase circuits should either have a Z_s value per line or the highest of the three values.</p> <p>When a Z_s value is established for a distribution circuit, it is also recorded on the schedule of test results for the distribution board the circuit is supplying, as Z_s at the distribution board.</p>
Expected results	<p>The results should be as low as possible.</p>
Verifying results	<p>Once values of Z_s are established and recorded, they can be checked against the maximum permissible values related to the type of circuit protective device and its rating.</p> <p>Maximum permitted values can be found in several places such as:</p> <ul style="list-style-type: none"> ● Tables B1–6 in the IET On-Site Guide, where direct comparison can be made. ● Tables A1–4 in Guidance Note 3, where direct comparison can be made. ● Tables 41.2–41.4 in BS 7671, where values in the tables need correcting due to operating temperatures. <ul style="list-style-type: none"> ● Table 41.2 is used where the circuit is protected by fuses and the circuit must disconnect in 0.4 seconds. ● Table 41.3 is used where the circuit is protected by circuit breakers or RCBOs and the circuit must disconnect in 0.4 or 5 seconds. ● Table 41.4 is used where the circuit is protected by fuses and the circuit must disconnect in 5 seconds. <p>As BS 7671 is intended primarily for designers, the maximum values of earth fault loop impedance in these tables are based on the circuit under load conditions. As the circuit was not loaded when testing was undertaken, the measured values of Z_s recorded on the schedule of test results must not exceed 80% of the values in BS 7671.</p> <p>For example, if a circuit was protected by a 32 A Type C circuit breaker, the Z_s value in the table is 0.68 Ω at operating temperature.</p> <p>The maximum test value should not exceed:</p> $0.68 \times 0.8 = 0.54 \Omega$ <p>So any test value of Z_s in this situation should not exceed 0.54 Ω.</p>
Something to consider	<p>If you decided to carry out a safe live EFLI test on a circuit where the Z_s values were calculated using Z_e added to the $R_1 + R_2$, the test value will likely be lower than the calculated value as the live test also takes in parallel paths. This is another good reason to use calculated values as they are the worst case.</p> <p>If you carry out a live test of EFLI on a ring-final circuit, the test value will certainly be much lower than the calculated value unless you tested the socket outlet closest to the midway point in the ring.</p> <p>If the value of EFLI for a circuit exceeds that permitted for a protective device but is acceptable for any RCD or the residual current trip of an RCBO, the designer of the installation must be consulted with regards to the protection of circuits under short-circuit conditions by use of the adiabatic equation given in Chapter 43 of BS 7671.</p>

▼ Table 6.14 Prospective fault current

Test	Prospective fault current (I_{pf})
Reasons for the test	To establish the maximum possible fault current for an installation and to ensure that protective devices are capable of withstanding the fault current and safely disconnecting wherever they are installed in the installation. Each device has a rated maximum current at which point they either explode or, in the case of circuit breakers, potentially fail and the contacts weld together. This value of current is called the rated short-circuit capacity in the case of fuses, circuit breakers and RCBs. Sometimes, the term breaking capacity is used in the case of fuses. It must be established that the breaking or short-circuit capacity of each protective device is suitable for the largest fault current likely where they are installed.
Meter to be used	Prospective fault current tester
Meter preparation	Some meters give prospective fault current readings when set to test earth fault loop impedance. Ensure you are familiar with your test instrument and always read the instructions. If a test instrument requires three leads to carry out this test, ensure you know what it is testing in terms of L-N or L-E. If in doubt, double up the earth and neutral leads so they are connected to the same terminal when testing.
Circuit preparation	Ideally, the supply is isolated. Ensure that everything, including the earthing conductor, is connected. Do not do this test as part of a Z_e test. This is because Z_e has the earth removed but prospective fault current needs all parallel paths included as this could raise the fault current.
Health and safety considerations	Never unnecessarily expose yourself to live terminals and always take extra care when testing live. As this is a live test, instruments and leads must comply with GS38.
Method	At the distribution board closest to the supply and on the supply side of the main switch: <ul style="list-style-type: none"> ● test for single-phase installations L-N (PSCC) then L-E (PEFC). ● test for three-phase installations L_1-N, L_2-N, L_3-N (all PSCC). There is no need to test the PEFC on a three-phase installation because the PEFC cannot be larger than the PSCC. As a fault between phases would be at 400 V, this makes it impossible for the PEFC to be larger.

KEY TERM**Safely disconnecting:**

In this situation we are considering if a device can disconnect without causing injury or damage, not about it meeting disconnection times.

INDUSTRY TIP

The test between L and N is called the prospective short-circuit current (PSCC). The test between L and E is called the prospective earth fault current (PEFC).

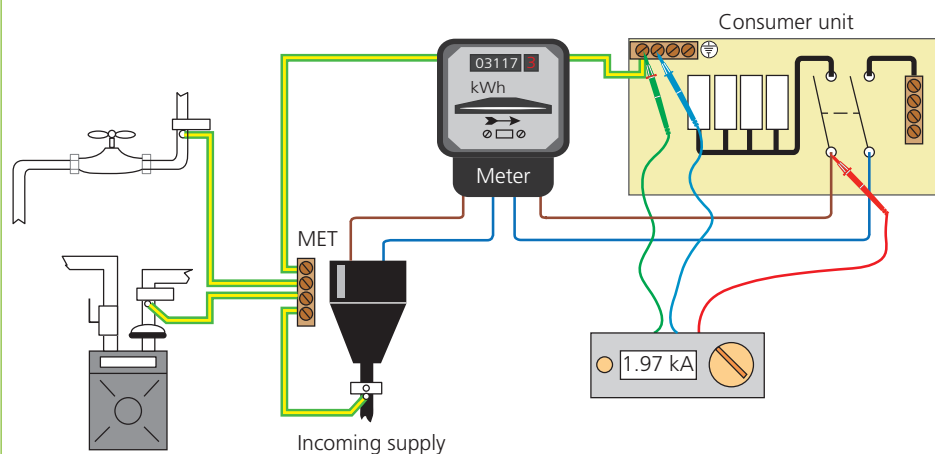

▲ Figure 6.38 Sometimes when testing prospective fault current using a three-lead tester, you may have to double up on the earth and neutral leads to get the most accurate results



INDUSTRY TIP

In dwellings where a consumer unit to **BS EN 61439** is used and the maximum prospective fault current declared by the DNO is 16 kA, it is not necessary to measure or calculate prospective fault current at the origin of the supply. See IET GN3 for more information.

Test	Prospective fault current (I_{pf})
What is recorded	Single-phase: the largest value of the two tests is taken and recorded in kilo-amperes (kA). Three-phase: the largest value of the three tests is taken and multiplied by two, to simulate a 400 V fault. The final result obtained is then recorded on the EIC and the schedule of test results for the distribution board where it was measured.
Verifying results	The recorded value of prospective fault current must not exceed the short-circuit capacities of any protective device in the installation. Table 7.2.7 in the IET On-Site Guide gives an overview of rated short-circuit capacities but if in doubt, the capacity should be on the device. If the capacity of a device at other distribution boards is less than that measured at the supply, further testing is required at that distribution board to establish that the I_{pf} has reduced sufficiently at that point in the installation.
Something to consider	Prospective fault current cannot get bigger in value in an installation, so the value recorded at the origin is the highest value. If for some reason it is not possible to test the I_{pf} , the value can be obtained by enquiry to the distribution network operator, but this will be an estimation.

▼ Table 6.15 Phase sequence



▲ Figure 6.39 Phase/sequence rotation tester

Test	Phase sequence
Reasons for the test	To ensure that the sequence of the three-phase supply conductors is maintained throughout the installation and to check that machines which are correctly wired rotate in the correct direction.
Meter to be used	Phase rotation tester This is a three-lead test set that could be either a rotating disc type (mini three-phase motor) or a digital display type.
Circuit preparation	This test must be undertaken before any phase-sequence sensitive equipment is energised.
Health and safety considerations	Never unnecessarily expose yourself to live terminals and always take extra care when testing live. As this is a live test, instruments and leads must comply with GS38.
Method	Connect the leads of the test equipment labelled or indicated as the correct sequence to the three-phase terminals where phase sensitive equipment is to be connected and check the given rotation as 'clockwise' or 'anticlockwise'. There isn't a correct way, although by convention, anticlockwise is considered correct, but it is expected that the same sequence should be obtained throughout the installation. If equipment is phase-sequence sensitive, check the manufacturer's handbook for correct sequence. Remember, phase rotation is checking the way machines rotate as described above, phase sequencing is checking that L1 remains L1 throughout the installation.
Something to consider	By swapping any two phases over, sequence will change.



▼ Table 6.16 Additional protection and functional testing of RCDs

Test	Additional protection and functional testing of RCDs
Reasons for the test	To ensure that any RCD functions as intended under simulated fault current conditions and when the test button is pushed.
Meter to be used	RCD tester
Meter preparation	Ensure that the test instrument is set to the residual current rating of the RCD. The test instrument requires three leads for this test.
Circuit preparation	The test must be undertaken on the load side of the RCD. If more than one RCD is in series, tests must be carried out on the load side of each RCD. In the case of an initial verification (but never when undertaking periodic testing), press the test button to check the RCD mechanism works before the instrument tests.
Health and safety considerations	Always test at the safest location, such as a socket outlet. As this is a live test, choose the location based on risk. For example, if you would need to use steps, it probably isn't the safest location and sometimes testing on the outgoing terminals of the RCD at the distribution board is safer. It makes no difference to the results where it is tested. As this is a live test, instruments and leads must comply with GS38. This test must be undertaken after earth fault loop impedance has been verified, as the test puts a fault into the earthing system.
Method	At the safest position, connect the meter to line, neutral and earth. With the instrument set to $0.5 \times I_{\Delta n}$, test. With the instrument set to 0° and $1 \times I_{\Delta n}$, test. Then test again at 180° . Some instruments have an auto-test facility that allows the inspector to stand by the RCD, resetting the RCD as the machine performs the above tests.
What is recorded	The highest of the $1 \times$ tests. These are recorded on the schedule of test results in the RCD tests columns.
Expected results	When tested at 0.5 times, the RCD should not trip (see below for others). If the device did trip, it could be prone to nuisance tripping, causing disruption and possibly danger as it is too sensitive.
Verifying results	General purpose RCDs must disconnect within: ● 300 milli-seconds at $1 \times$ test. For additional protection requirements, the RCD should be rated no more than 30 mA.
Something to consider	Time delayed (S type) RCDs may be installed to provide suitable selectivity . Check Table 3A of BS 7671 for their disconnection time range. As well as the function of RCDs being checked, the operation of other devices and equipment should also be checked to ensure they function. This is a simple test where you simply turn things on and off to make sure they work. Sockets can be functionally tested by plugging in a socket-type polarity indicator.

INDUSTRY TIP

Check your test instrument as all testers are different.
When testing an RCD upstream of another RCD, but the RCD nearest the origin trips first, testing across the RCD is possible (subject to instrument) by placing probes across the load neutral and supply side line of the RCD. See IET GN3 for more details or consult your instrument instructions.

INDUSTRY TIP

RCDs should be tested every six months by operating the test button. Many people do not do this because they then have to reset all their electrical clocks and other similar items when they do this test.

However, remember that the time changes every six months, so it is advisable to test RCDs when the hour goes forward or back. It helps people to remember to test their RCDs and causes less inconvenience.

KEY TERM

Selectivity: Previously called *discrimination*, this is where a device, such as a time-delay RCD used as a main switch, is selected to ensure that local devices trip first. If a problem persists, the time-delay RCD will trip, cutting the entire supply.

▼ Table 6.17 Verification of voltage drop

Test	Verification of voltage drop
Reasons for the test	To verify that the voltage at the end of each circuit is sufficient to allow for correct operation of equipment. Too much voltage drop could impair the safe operation of equipment.
Meter to be used	Low-resistance ohmmeter
Additional equipment needed	Temporary link lead
Meter preparation	Ensure that the meter functions and all leads used are nulled or zeroed.
Circuit preparation	The circuit must be isolated from the supply for this test and a temporary link made between line and neutral at the distribution board.
Health and safety considerations	The circuit must be isolated. Ideally, the whole distribution board should be isolated.
Method	With the link made between line and neutral at the distribution board, test between line and neutral at the furthest point in the circuit.
What is recorded	No results are recorded but if the voltage drop exceeds permitted values, the circuit must be corrected before certification is issued.
Expected results	<p>This depends on circuit length and conductor csa.</p> <p>Voltage drop can be calculated using the measured value, circuit design current (I_b) and the use of a temperature factor. The temperature factor is applied to adjust the measured resistance of the no-loaded circuit to that of a fully loaded circuit. The normal factor applied to do this is 1.2 to simulate a temperature rise from 20°C to 70°C.</p> <p>The voltage drop can then be calculated by:</p> $(R_1 + R_n) \times I_b \times 1.2 = \text{voltage drop (V)}$ <p>Consider a power circuit has a design current of 15 A and $R_1 + R_2$ was measured as 0.34 Ω at 20°C. The voltage drop would be:</p> $0.34 \times 15 \times 1.2 = 6.12 \text{ V}$
Verifying results	<p>The voltage drop of a circuit must not exceed that given in Appendix 4 of BS 7671 for installations connected to a public supply, which are:</p> <ul style="list-style-type: none"> ● 3% of the supply voltage for lighting circuits, which is 6.9 V for a 230 V supply and ● 5% of the supply voltage for power circuits, which is 11.5 V for a 230 V supply. <p>As our example was 6.12 V and the circuit is a power circuit, this is acceptable.</p>
Something to consider	Testing for voltage drop is generally not required for an initial verification if the installation has been designed correctly and installed as per the design. It may, however, be required for periodic inspection and testing if it is thought that equipment isn't functioning correctly, such as dim lights or heaters not heating up correctly.



Completed documentation

All electrical installation work must be designed, constructed, inspected and tested. When the inspection and testing is complete, the customer will be supplied with the relevant copies of the certification.

Electrical Installation Certificate

An Electrical Installation Certificate is a safety certificate issued to confirm that the electrical installation work to which it relates has been designed, constructed, inspected and tested in accordance with **BS 7671** The IET Wiring Regulations. As part of the certification, the Schedule of Circuit Details and the Schedule of Test Results must be completed with satisfactory outcomes.

The recipient should receive an 'original' certificate and the contractor should retain a duplicate. If you are the person ordering the work, but not the owner of

the installation, you should pass this certificate, or a full copy of it including the schedules, immediately to the owner.

The 'original' certificate should be retained in a safe place to be shown to any person inspecting or undertaking further work on the electrical installation in the future. If the property is later vacated, this certificate will demonstrate to the new owner that the electrical installation complied with the requirements of **BS 7671** at the time the certificate was issued. The Construction (Design and Management) Regulations require that, for a project covered by those regulations, a copy of this certificate, together with schedules, is included in the project health and safety documentation.

Minor Electrical Installations Works Certificate

A Minor Electrical Installations Works Certificate will be issued to confirm that the electrical installation work to which it relates has been designed, constructed, inspected and tested in accordance with **BS 7671** The IET Wiring Regulations.

Similarly, the recipient should receive an 'original' certificate and the contractor should retain a duplicate and, if necessary, the original certificate should be passed to the owner.

A separate certificate should be received for each existing circuit on which minor works have been carried out. This certificate is not appropriate if the contractor has undertaken more extensive installation work, for which an Electrical Installation Certificate is required.

As above, it should be retained in a safe place, displayed to any person inspecting or undertaking further work on the electrical installation, and if the property is later vacated, it will provide proof that the minor electrical installation work carried out complied with the requirements of **BS 7671** at the time the certificate was issued.

Schedule of Inspections

The Schedule of Inspections is completed as part of the Electrical Installation Certificate. This document must be completed with no faults recorded.

Generic Schedule of Test Results

The Schedule of Test Results is completed and supplied as part of the Electrical Installation Certificate. This document must be completed with no faults recorded and presented as part of the Electrical Installation Certificate. Complex installations may require more than one Schedule of Test Results. One schedule must be completed for each distribution board and consumer control unit (including distribution circuits).

Accompanying each Schedule of Test Results should be the Schedule of Circuit Details which carries all the information needed for each circuit.

Commissioning equipment

It is vitally important to follow manufacturers' documentation when setting up and commissioning electrical and electronic equipment. These instructions should be passed on to the client for future needs. They should form part of an Operation and Maintenance (O&M) manual.

Test your knowledge

- 1 What must happen if a defect is found during an initial verification?
 - a The defect is recorded on an Electrical Installation Condition Report, the report is then issued to the client.
 - b The defect is recorded on an Electrical Installation Certificate, the report is then issued to the client.
 - c The defect is ignored and the Electrical Installation Certificate is issued to the client.
 - d The defect is corrected, re-tested and an Electrical Installation Certificate is issued to the client.
- 2 What human sense is used to detect a loose terminal during the inspection of a new installation?
 - a Sight.
 - b Touch.
 - c Smell.
 - d Hearing.
- 3 Which column on a schedule of test results is used to record the continuity of line conductor during step 1 of a ring-final circuit test?
 - a R_2
 - b r_1
 - c r_n
 - d R_1
- 4 What would be inspected when the basic protection by barriers and enclosures is being verified on a three-phase distribution board?
 - a IP ratings.
 - b RCBO ratings.
 - c Terminations.
 - d Isolation.
- 5 What must be done with a low-resistance ohmmeter to ensure accurate results are obtained each time it is used?
 - a Calibration.
 - b Lead zeroing.
 - c Battery replacement.
 - d Test on known supply.
- 6 What are the three standard test voltages an insulation resistance tester provides?
 - a 100 V AC, 250 V AC, 500 V AC
 - b 230 V AC, 500 V AC, 1000 V AC
 - c 250 V DC, 500 V DC, 1000 V DC
 - d 500 V DC, 1000 V DC, 1500 V DC
- 7 What test current is applied to a 30 mA RCBO to check that it is not too sensitive?
 - a 15 mA
 - b 30 mA
 - c 50 mA
 - d 150 mA

- 8 What time must RCBOs trip within, when tested at $1 \times I_{\Delta N}$?
- 10 ms
 - 40 ms
 - 200 ms
 - 300 ms
- 9 What is the purpose of a PFC test?
- To confirm disconnection times are met in the event of a fault.
 - To ensure the circuit conductors are suitably sized for faults.
 - To verify that protective devices can safely withstand faults.
 - To check that protective devices are the correct rating and type.
- 10 Who is responsible for setting the interval between an initial verification and the first periodic inspection and test?
- The inspector.
 - The installer.
 - The designer.
 - The architect.
- 11 List the first three tests undertaken on a new lighting circuit.
- 12 Three individual circuits had insulation resistance values between live and earth of:
- 10 M Ω
 - 10 M Ω
 - 5 M Ω
- Determine the value of insulation resistance if the circuits were all tested together at the same time.
- 13 A test of earth fault loop impedance gave a result of 0.9 Ω on a circuit protected by a 32 A Type B circuit breaker. Determine if this is acceptable.
- 14 Explain why details of test instruments are listed on a schedule of test results.
- 15 Explain why the client should test an RCD, using a test button, every six months.
- 16 Which statutory document requires an inspector to be competent?
- EWR
 - HSWA
 - BS 7671
 - HSE GS38
- 17 Which of the following is a non-statutory document that gives specific guidance on the inspection and testing process?
- IET GN1
 - IET GN3
 - IET GN5
 - IET GN7

- 18** Which example of electrical work would be certificated using a Minor Works Certificate?
- a** Adding a circuit to an existing installation.
 - b** Rewiring a complete installation.
 - c** Wiring a complete new installation.
 - d** Adding a socket to an existing circuit.
- 19** A distribution board without a lockable lid is being inspected for basic protection. What is the **minimum** level of IP protection for the front of this unit?
- a** IP2X
 - b** IPX2
 - c** IP4X
 - d** IPX4
- 20** BS 7671 gives requirements for undertaking tests on new installations and the tests include the following:
- 1** Insulation resistance.
 - 2** Continuity of protective conductors.
 - 3** Polarity.
 - 4** Continuity of ring-final circuits.
 - 5** Earth fault loop impedance.
- What are the first three tests, in order, that should be carried out on a newly installed lighting circuit during initial verification?
- a** 2, 1, 3.
 - b** 1, 3, 4.
 - c** 2, 3, 1.
 - d** 1, 5, 4.
- 21** A circuit which is 50 m long has an $R_1 + R_2$ value of 0.2 Ω . What would be the value of $R_1 + R_2$ if the circuit was extended to 100 m using the same csa cable?
- a** 0.05 Ω
 - b** 0.10 Ω
 - c** 0.20 Ω
 - d** 0.40 Ω
- 22** A test for the continuity of a protective bonding conductor is to be carried out. What is the value of resistance that should be allowed for the bonding clamp to a pipe according to GN3?
- a** 0.01 Ω
 - b** 0.05 Ω
 - c** 0.10 Ω
 - d** 0.50 Ω

23 A test of PFC is to be undertaken on a three-phase installation and the measured values between each line and neutral were

- L1-N: 1.3 kA
- L2-N: 1.35 kA
- L3-N: 1.28 kA

What is recorded as the overall PFC?

- a** 1.28 kA
- b** 1.35 kA
- c** 2.70 kA
- d** 3.93 kA

24 A test of continuity of ring-final circuits is being undertaken and the initial step 1 results were:

- $r_1 - 0.4 \Omega$
- $r_n - 0.4 \Omega$
- $r_2 - 0.67 \Omega$

Calculate what results are expected during step 2 and step 3 of the test.

25 An $R_1 + R_2$ test was measured on a radial circuit and a value of 1.61Ω was recorded. Calculate the value of R_2 only if the line and cpc csa are $2.5/1.5 \text{ mm}^2$.

26 Explain, for a typical installation, why a direct measurement of earth fault loop impedance is likely to be lower than adding the measured $R_1 + R_2$ to the measured Z_e .

27 An earth electrode resistance test produced the following three readings: 46Ω , 44Ω , 47Ω . Determine if these are acceptable and what is recorded as the overall value on test documentation.

Practical task

Design a method statement detailing the full range of tests expected on a typical domestic installation and include on the document:

- initial safety considerations
- circuit preparation
- instrument selection and preparation
- how results are verified, where applicable.

ELECTRICAL SYSTEM FAULT DIAGNOSIS AND RECTIFICATION

INTRODUCTION

There are many types of fault that can occur in electrical circuits. These include not only the failure of physical components but also errors that may have been introduced during the original design or installation. This chapter will help you understand the principles, practices and legislation associated with diagnosing and correcting electrical faults in accordance with statutory and non-statutory regulations and requirements. This knowledge underpins the application of skills used for fault diagnosis and correction in electrotechnical systems and equipment in buildings, structures and the environment.

HOW THIS CHAPTER IS ORGANISED

We have covered the installation process from understanding **BS 7671** The IET Wiring Regulations to design and the inspection and testing process. In this chapter, we will be looking at what could go wrong with an installation once it is placed into service.

Working on faulty systems is a high-risk area, so understanding the regulatory requirements is a key safety factor. We also need to know the correct ways to record and report faulty or unsafe situations and how these should be acted on. Understanding symptoms of faults to be able to diagnose and locate them takes a great deal of skill and logic and once a fault is located, we must know how to rectify it.

Table 7.1 shows the topics covered in this chapter.

▼ Table 7.1 Chapter 7 assessment criteria coverage

Topic	5357-014/114 Understand Fault Diagnosis and Rectification	2365-303 Electrical Installations: Fault Diagnosis and Rectification	8202-306 Electrical System Fault Diagnosis and Rectification	5393-114/014 Understand Fault Diagnosis and Rectification
Safety and regulatory requirements	1.1; 1.2; 1.3 4.1; 4.3	1.1; 1.2; 1.3 4.1; 4.3	1.1; 1.2; 1.3 4.1; 4.3	1.1; 1.2; 1.3; 1.4 4.1; 4.3
Reporting and recording fault diagnosis work	2.1; 2.2; 2.3	2.1; 2.2; 2.3	2.1; 2.2; 2.3	2.1; 2.2
Fault diagnosis procedures	3.1; 3.2; 3.3 4.2; 4.3; 4.4; 4.5; 4.6	3.1; 3.2; 3.3 4.2; 4.3; 4.4; 4.5; 4.6	3.1; 3.2; 3.3 4.2; 4.3; 4.4	3.1; 3.2; 3.3; 3.4; 3.5; 3.6
Fault rectification	5.1; 5.2; 5.3	5.1; 5.2; 5.3	5.1; 5.2; 5.3	4.2; 4.3; 4.4; 4.5; 4.6

T Level mapping grids are available on the Hodder Education website. These map the book to the occupational specialisms: 8710-353 (Electrical Engineering) and 8710-352 (Electrical and Electronic Equipment).

SAFETY AND REGULATORY REQUIREMENTS

Fault finding can introduce many risks, especially when you are unsure what you are looking for. One of the high-risk areas of working with electricity is looking for faults without implementing a safe system of working. Far too much can go wrong, and things do not behave as expected. Because of this, adopting a safe system of working is a must for the safety of yourselves and others and it leads to much more efficient diagnosis.

Health and safety legislation

The basic concept of 'health and safety legislation' is to provide the legal framework for the protection of people from illness and physical injury that may occur in the workplace. The Health and Safety at Work Act (HSW) 1974 is the basis of all British health and safety law. It provides a comprehensive and integrated piece of legislation that sets out the general duties that employers have towards employees, contractors and members of the public, and that employees have to themselves and to each other. These duties are qualified in the HSW Act by the principle of 'so far as is reasonably practicable'. What the law expects is what good management and common sense would lead employers to do anyway: that is, to look at what the risks are and take sensible measures to tackle those risks.

The person(s) responsible for the risk and best placed to control that risk are usually designated the **duty holder**. The HSW Act, which is an enabling act, is based on the principle that those who create risks to employees or others in the course of carrying out work activities are responsible for controlling those risks. The Act places specific responsibilities on the following:

- employers
- self-employed workers
- employees
- designers
- manufacturers and suppliers
- importers.

The HSW Act lays down the general legal framework for health and safety in the workplace with specific duties being contained in regulations also called **Statutory Instruments** which are also examples of laws approved by Parliament. The HSW Act, and general duties in the Management of Health and Safety at Work Regulations 1999, are goal setting and leave employers the freedom to decide how to control risks that they identify.

However, some risks are so great, or the proper control measures so costly, that it would not be appropriate to leave employers to decide what to do about them. Regulations, such as the Electricity at Work Regulations (EAWR) 1989, identify these risks and set out the specific action that must be taken.

INDUSTRY TIP

Review the Health and Safety at Work Act 1974 and the Electricity at Work Regulations 1989, by visiting the HSE website.

KEY TERMS

Duty holder: The person in control of the danger is the duty holder. This person must be competent by formal training and experience and with sufficient knowledge to avoid danger. The level of competence will differ for different items of work.

Statutory Instruments: Acts of Parliament that give powers to another body or organisation to act on those powers. The HSE are empowered under the Health and Safety at Work Act to enforce the Act on behalf of Parliament.

The Electricity at Work Regulations 1989 are the main statutory regulations that deal with work on electrical systems and require people in control of electrical systems to ensure they are safe to use and maintained in a safe condition.

Statutory regulations covering building types

Maintenance activities, such as periodic inspection and testing, are made mandatory in some buildings due to statutory regulations covering these buildings.

Examples of these regulations include:

- the Electrical Safety Standards in the Private Rented Sector (England) Regulations 2020
- the Management of Houses of Multiple Occupation (England) Regulations 2020.

In addition, local authorities place a duty on some buildings to be regularly maintained, and this again can be proven by undertaking periodic inspection and testing at regular intervals. Examples of these are buildings requiring a licence such as:

- buildings selling alcohol
- places of public entertainment
- petrol filling stations
- touring caravan parks.

Generally, all commercial buildings are classed as places of work, so Regulation 4 of the Electricity at Work Regulations 1989 states the need for these buildings to be maintained to a safe condition.

Many hazardous installations, such as chemical plants, are covered by specific statutory regulations and some of these are detailed in Appendix 2 of BS 7671.

HEALTH AND SAFETY

Following guidance and non-statutory regulations is not compulsory and employers are free to take other action, but if they do follow the guidance they will normally be doing enough to comply with the law.

Guidance and non-statutory regulations

The HSE and other organisations publish guidance and non-statutory regulations on a range of subjects. Guidance can be specific to the health and safety problems of an industry or of a particular process used in a number of industries.

The main purposes of guidance are:

- to help people interpret and understand what the law says
- to help people comply with the law
- to give technical advice.

BS 7671 The IET Wiring Regulations

One very good example of guidance and non-statutory regulations is **BS 7671**, more usually known as the 'IET Wiring Regulations'. BS 7671 is the national standard in the United Kingdom for low-voltage electrical installations. The regulations deal with the design, selection, erection, inspection and testing of electrical installations operating at a voltage up to 1000 V AC and 1500 V DC.

If electrotechnical work is undertaken in accordance with BS 7671 it is almost certain to meet the requirements of the statutory regulations (the Electricity at Work Regulations) dealing with work with electrical equipment and systems.

Electricity

BS 7671, which is non-statutory regulations, relates principally to the design and erection of electrical installations so as to provide for safety and proper functioning for the intended use. If an installation is constructed in accordance with BS 7671, protection should be afforded to the user from:

- electric shock
- excessive temperature
- under-voltage, overvoltage and electromagnetic disturbances
- power supply interruptions
- arcing and burning.

However, a great number of electrical accidents occur because people are working on or near equipment that is thought to be dead but which is in fact live, or the equipment is known to be live but those involved in the work do not have adequate training or appropriate equipment, or they have not taken adequate precautions.

Regulation 4(3) of the EAWR requires that every work activity, including operation, use and maintenance of a system and work near a system, shall be carried out in such a manner as not to give rise, so far as is reasonably practicable, to danger.

The EAWR provides for two basic types of system of work: work on de-energised conductors (Regulation 13) and work on live conductors (Regulation 14).

Regulation 13 covers the preferred system of working, which is to remove the danger at source, i.e. by making the conductors dead. Regulation 14 requires adequate safeguards to protect the person at work from the hazards of live conductors.

Many accidents to electricians, technicians and electrical engineers occur when they are working on equipment that could have been isolated. In most cases, adequate planning and work programming will allow such jobs to be carried out as the regulations require, i.e. with the equipment dead and **isolated**.

Safe isolations

The preparation of electrical equipment for fault diagnosis and repair purposes often requires effective disconnection from all live supplies and a means for securing that disconnection, for example, by locking off with a suitable lock and single key. There is an important distinction between switching and isolation.

Switching is cutting off the supply while isolation is the secure disconnection and separation from all sources of electrical energy. A variety of control devices is available for switching, isolation or a combination of these functions, some incorporating protective devices.

Before starting work on a piece of isolated equipment, checks should be made, using an approved testing device, to ensure that the circuit is dead. See below for details of a standard isolation procedure. There are also secondary hazards associated with electrical testing that must be considered when risk assessments and a safe work practice document are being prepared.

HEALTH AND SAFETY

The big problem with electricity is obviously that you cannot see it. You can see the effects of electricity but a disconnected and dead cable looks exactly the same as a live cable. Only knowledge and the use of the correct instrumentation will prove it to be live or dead.

KEY TERM

Isolation: The disconnection and separation of the electrical equipment from every source of electrical energy in such a way that this disconnection and separation is secure.

HEALTH AND SAFETY

If the device used for the purpose of isolation is a fuse or removable handle instead of a lockable device, keep this securely under supervision while work is undertaken. If more than one person is working on a circuit, a multi-lock device should be used.

Safe isolation procedure step by step

A standard procedure for isolation is as follows.

- 1 Select an approved voltage indicator to GS38 and confirm operation.
- 2 Locate correct source of supply to the section needing isolation.
- 3 Confirm that the device used for isolation is suitable and may be secured effectively.
- 4 Power down circuit loads if the isolator is not suitable for on-load switching.
- 5 Disconnect using the located isolator (from step 2).
- 6 Secure in the off position, keep key on person and post warning signs.
- 7 Using voltage indicator, confirm isolation by checking ALL combinations.
- 8 Prove voltage indicator on known source, such as proving unit.

Carrying out a safe isolation procedure will safeguard not only the person undertaking work on the installation, but also other people who may be working within the building, such as:

- occupiers and other trades people (who may be inconvenienced by loss of supply to essential equipment/machinery)
- the customer or client for whom the work is being done (who may suffer from loss of service and downtime)
- members of the public (who are exposed to possible danger due to loss of essential services such as fire-alarm systems, emergency or escape lighting)
- those who require the continued provision of a supply for data and communication systems.

Remember that, if isolation is required to be carried out on a distribution board that is in a communal area, such as at the entrance to flats, a shop or hotel, there will be additional requirements, such as barriers and notices to prevent unauthorised access to the work area.

Potential consequences of not ensuring safe isolations

If the correct isolation procedure is not undertaken, it can have implications not only for the person who is carrying out the work on the installation but also for other people, such as the occupiers of the building, clients or customers, other trades or personnel working within the building and members of the public.

The implications:

- to the person carrying out the work and to members of the public – risk of electric shock or burns
- to the occupiers of the building – risk of contact with electrical parts when basic protection has been removed
- to clients and customers – risk of shock or burns and damage to equipment.

An incorrect isolation procedure may also present a risk of damage to electrical equipment and to building fabric.

Safe working procedures for fault diagnosis

Electricity is a safe, clean and powerful source of energy and is in use in practically every factory, office, workshop and home in the country. However, this energy source can also be very hazardous – with a risk of causing death, if it is not treated with care. Injury can occur when live electrical parts are exposed and can be touched, or when metalwork that is meant to be earthed becomes live at a dangerous voltage.

The possibility of touching live parts is increased during electrical testing and fault-finding, when conductors at dangerous voltages are often exposed. This risk can be reduced if testing is done while the equipment is isolated from any source of electrical supply. However, this is not always possible and, if this is the case, it is important to follow procedures that prevent contact with any hazardous voltages internal to the system.

But before fault finding and testing work commences, reference must be made to the following relevant legal duties.

- The Electricity at Work Regulations 1989 (EAWR)
 - This is the principal legislation relating to work on electrical systems.
 - Regulation 4(3) requires that: 'work on or near to an electrical system shall be carried out in such a manner as not to give rise, so far as is reasonably practicable, to danger'.
 - The regulations provide for two basic types of system of work: work on de-energised conductors (Regulation 13) and work on live conductors (Regulation 14).
- The Management of Health and Safety at Work Regulations 1999
 - These require employers to assess the risks to the health and safety of their employees while they are at work, in order to identify and put in place the necessary precautions to ensure safety.
 - Depending on the extent of the work, this requires either a formal written risk assessment or one that relies on a generic system for simple work activities. A sample risk assessment is shown in Figure 7.2.



▲ Figure 7.1 Make sure all precautions are taken

What are the hazards?	Who might be harmed and how?	What actions have been taken?	Any further actions required to manage this risk?	Action by whom?	Action by when?	Done
Electric shock	<p>Staff carrying out fault finding.</p> <p>Failure to carry out correct isolation procedure prior to testing; Working on equipment that is live; Failure to provide suitable barriers where live equipment needs to be shrouded; Use of faulty test equipment; Failure to use appropriate PPE Unsafe situations left unresolved.</p> <p>Visitors to and occupants of the building.</p> <p>Test area not properly guarded and notices not posted; Making contact with exposed conductive parts during testing</p>	<p>All electricians have received training in the following:</p> <p>Correct method of isolation; Safe testing procedures; Safe use of test instruments First aid training; Correct selection and use of PPE Correct procedure regarding action to be taken if unsafe situations are identified</p> <p>All electricians have received training in the following:</p> <p>Safe work area demarcation – barriers, notices.</p>	Regular audits by supervisor to confirm correct testing procedures are being observed; Refresher training for all electricians.	Supervisor	01/02/2022	01/02/2022
Lone working	<p>Lone worker.</p> <p>Increased risk of injury due to being unable to summon assistance.</p>	<p>All electricians have received effective means of communication (eg landline or mobile phone). Any person working alone will notify their supervisor of their itinerary including where they will be working and what time they expect to finish.</p>	No	Supervisor	01/02/2022	01/02/2022
Asbestos	<p>Staff carrying out fault finding.</p> <p>Failure to identify presence of asbestos and drilling or abrading asbestos board or ceiling tiles</p>	<p>All electricians have received training in the following: Asbestos awareness</p> <p>A risk assessment has been carried out and a safe system of work prepared.</p>				
Slips trips and falls	<p>Staff and visitors.</p> <p>May be injured if they trip over objects or slip on spillages</p>	<p>General good housekeeping. All areas are well lit including stairs. There are no trailing leads or cables. Staff to keep work areas clear, eg no boxes left in walkways.</p>	Better housekeeping is needed in staff kitchen, eg on spills.	Site responsible person. All staff, supervisor to monitor	01/02/2022	01/02/2022

▲ Figure 7.2 Sample risk assessment

The method statement

Once the risk assessment has been carried out, a safe system of work, sometimes called a method statement, can be prepared to enable the work to be undertaken in a safe manner. Risk assessments and method statements are often known collectively by the acronym RAMS: Risk Assessment and Method Statement.

The safe system of work or method statement will include such items as:

- who is authorised to undertake testing and, where appropriate, how to access a test area and who should not enter the test area
- arrangements for isolating equipment and how the isolation is secured
- provision and use of personal protective equipment (PPE) where necessary
- the correct use of tools and equipment
- the correct use of additional protection measures, e.g. flexible insulation that may need to be applied to the equipment under test while its covers are removed
- use of barriers and positioning of notices
- safe and correct use of measuring instruments

- safe working arrangements to be agreed with client, duty holder or responsible person
- how defects are to be reported and recorded
- instructions regarding action to be taken if unsafe situations are identified.

Details of safe systems of work or safe working procedures for fault diagnosis, testing and fault repair activities should, wherever it is reasonably practicable to do so, be written down.

Safe working procedures should be reviewed regularly, to make sure that they are being followed and are still appropriate for the work that is being carried out. If any changes are made to the procedures, all people who are involved in the fault diagnosis regime should be given relevant instruction and training.

Permit to work

A permit to work (PTW) procedure is a specialised written safe system of work that ensures potentially dangerous work, such as work on high-voltage electrical systems (above 1000 V) or complex lower-voltage electrical systems, is done safely. The PTW also serves as a means of communication between those controlling the danger (the duty holder) and those who carry out the hazardous work.

Essential features of PTW systems are:

- clear identification of who may authorise particular jobs (and any limits to their authority), and who is responsible for specifying the necessary precautions
- that the permit should only be issued by a technically competent person, who is familiar with the system and equipment, and who is authorised in writing by the employer to issue such documents
- provision of training and instruction in the issue, use and closure of permits
- monitoring and auditing to ensure that the PTW system works as intended
- clear identification of the types of work considered hazardous
- clear and standardised identification of tasks, risk assessments, permitted task duration and any additional activity or control measure that occurs at the same time.

A PTW should state clearly:

- the person the permit is addressed to, that is the person carrying out the work or the leader of the group or working party who will be present throughout the work
- the exact equipment that has been made dead and its precise location
- the points of isolation
- where the conductors are earthed (on high-voltage systems)
- where warning notices are posted and special safety locks fitted
- the nature of the work to be carried out
- the presence of any other source of hazard, with cross-reference to other relevant permits
- further precautions to be taken during the course of the work.

INDUSTRY TIP

Guidance on the Electricity at Work Regulations 1989 (HSR 25) can be downloaded free of charge from the HSE website.

The effective operation of a PTW system requires involvement and cooperation from a number of people, and the procedure for issuing a PTW should be written down and adhered to.

IMPROVE YOUR ENGLISH



Ensure that the instructions on the permit to work are written in clear language so there is no chance of misunderstanding what is required.

INDUSTRY TIP

Good communication is key when dealing with clients. Always keep them informed of downtimes and disruptions so they can plan for them.

Planning and agreeing procedures

Plan your maintenance activity carefully, so when you approach the client to agree safe working arrangements and downtimes, you are clear you know what you will do.

Consider what tools and equipment are needed, as well as the time each activity will take to complete. Activities include:

- selecting tools and equipment
- creating or obtaining method statements and risk assessments
- carrying out safe isolation procedure
- carrying out the maintenance activity
- commissioning repair or replacement where needed, including any functional testing
- removing the secure isolation.

Before fault diagnosis is carried out, the safe working arrangements must be discussed and agreed with the client and/or the duty holder (or responsible person for the installation).

IMPROVE YOUR ENGLISH



When communicating with the client or duty holder, make sure you do so in a clear, concise and courteous manner. This demonstrates your professionalism, as well as ensuring all involved understand the process and designated responsibilities. Do not bombard them with technical information as they may not understand you. Duty holders are not necessarily electrically competent people so use simple, clear language.

VALUES AND BEHAVIOURS

The testing and inspection procedure must be a planned activity as it will almost certainly affect people who work or live in the premises where the installation is being tested. It is good practice to make sure the client understands any effects this could have on their day to day routine to prepare for any potential disruptions that may arise.

This ensures that everyone who is concerned with the work understands what actions need to be taken, such as:

- which areas of the installation may be subject to disconnection
- anticipated disruption times

- who might be affected by the work
- health and safety requirements for the site
- which area will have restricted access
- whether temporary supplies will be required while the fault diagnosis is underway
- reaching agreement on who has authority for the diagnosis and repair.

It may be that a specific person has responsibility for the safe isolation of a particular section of an installation and that person should be identified and the isolation arrangements agreed. By entering into dialogue with the client before work commences, the potential for unforeseen events will be minimised and good customer relations will be fostered. For example, in an office block where the electrical installation is complex and provides supplies to many different tenants located on a number of floors, the safe isolation of a sub-circuit for testing purposes may require a larger portion of the installation to be turned off initially. In order to achieve this with minimal disruption, an agreement must be reached between the competent person tasked to carry out the work and the person responsible for the installations affected. This responsible person could be the office manager, the designated electrical engineer for the site or, in some cases, the landlord of the building.

HEALTH AND SAFETY

You should appreciate the difference between ‘the duty holder’ and ‘the responsible person’.

- The person in control of the danger is the duty holder. This person must be competent by formal training and experience and with sufficient knowledge to avoid danger. The level of competence will differ for different items of work.
- The person who is designated the responsible person has delegated responsibility for certain aspects of a company’s operational functions, such as fire safety, electrical operational safety or the day-to-day responsibility for controlling any identified risk, such as *Legionella* bacteria.

INDUSTRY TIP

The Electricity at Work Regulations considers a competent person as someone with suitable knowledge and experience to carry out the work. **BS 7671** no longer refers to a person as ‘competent’ but instead uses the terms ‘Skilled Person (electrically)’ and ‘Instructed Person (electrically)’.

- A skilled person is someone who, like a competent person, has suitable knowledge and experience but the definition goes further, stating that the skilled person must also be able to perceive (understand and be aware of) the risks electricity can create in all situations.
- Instructed persons are those that have knowledge and experience in particular tasks but cannot necessarily perceive the risk when those situations change.

Everyone involved in the work (e.g. client, electrician and those in the workplace) has a responsibility for their own health and safety and that of others who may be affected by the work.

IMPROVE YOUR ENGLISH



Remember, clear communication between all parties will ensure compliance with the respective health and safety requirements.

INDUSTRY TIP

Access the Electrical test equipment for use on low voltage electrical systems Guidance Note GS38 (Fourth edition), by visiting the HSE website.

Safe and correct use of measuring instruments

In fault diagnosis, the use of suitable and safe voltage-indicating devices and measuring instruments is as important as the competency of the person undertaking the fault-finding activities. The possibility of touching live parts is increased during electrical testing and fault finding, when conductors at dangerous voltages are often exposed. The risks can be reduced if testing is done while the equipment or part of an installation is made dead and is isolated from any dangerous source of electrical supply. Special attention should be paid when carrying out tests with instruments capable of generating test voltages greater than 50 V or which use the supply voltage for the purpose of earth-loop testing or a residual-current device test.

Refer back to Chapter 6 of this book for more information.

Use of instruments for fault diagnosis

The HSE has produced Guidance Note GS38 (Electrical test equipment for use on low voltage electrical systems), which is intended to provide guidance for electrically competent people, including electricians, electrical contractors, test supervisors, technicians, managers and/or appliance retailers. It offers advice in the selection and use of test probes, leads, lamps and voltage-indicating devices.

Using instruments safely

When using test instruments to carry out fault diagnosis, follow these basic precautions to achieve safe working.

Understanding the equipment

Make sure you are familiar with the instrument to be used and its ranges; check its suitability for the characteristics of the installation it will be used on.

Self-test

Many organisations regularly test instruments on known values to ensure they remain accurate. These tests would be documented.

Calibration

All electrical test instruments should be calibrated on a regular basis. The time between calibrations will depend on the amount of usage that the instrument receives, although this should not exceed 12 months under any circumstances.

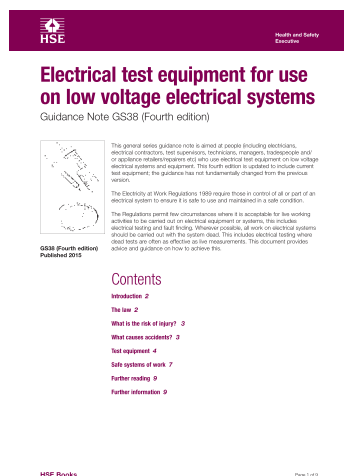

▲ Figure 7.3 Guidance Note GS38, an essential tool for electricians and others

HEALTH AND SAFETY

Remember the requirements of GS38? We covered this document in Chapter 6.

Instruments have to be calibrated under laboratory conditions, against standards that can be traced back to national standards; therefore, this usually means returning the instrument to a specialist laboratory.

Once calibrated, the instrument will have a calibration label attached to it, stating the date the calibration took place and the date the next calibration is due. It will also be issued with a calibration certificate, detailing the tests that have been carried out, and a reference to the equipment used.

Instruments that are subject to any electrical or mechanical misuse (e.g. if the instrument undergoes an electrical short circuit or is dropped) should be returned for recalibration before being used again.

Electrical test instruments are relatively delicate and expensive items of equipment and should be handled with care. When not in use, they should be stored in clean, dry conditions at normal room temperature. Care should also be taken of instrument leads and probes, to prevent damage to their insulation and to maintain them in safe working condition.

Check test leads

Make sure that these and any associated probes or clips are in good order, are clean and have no cracked or broken insulation. Where appropriate, the requirements of the HSE Guidance Note GS38 should be observed for test leads.

Select appropriate scales and settings

It is essential that the correct scale and settings are selected for an instrument. Manufacturers' instructions must be observed under all circumstances.

Tools and equipment

The responsibilities of users of work equipment are covered in Section 7 of the HSW Act and Regulation 14 of the Management of Health and Safety at Work Regulations. Work equipment includes hand tools and hand-held power tools.

- Section 7 of the HSW Act requires employees to take reasonable care for themselves and for others who may be affected by their acts or omissions at work and to cooperate with the employer to enable the employer to discharge their duties under the Act.
- Regulation 14 of the Management Regulations requires employees to use equipment properly in accordance with instructions and training and to report to the employer any dangerous situations that might arise during the course of their work.

The hand tools that are most commonly used in electrical installation work are: screwdrivers, pliers, side cutters, hacksaw, adjustable spanners, hammers, chisels, cold chisels, files, centre punches, wire strippers, cable strippers, crimpers, ratchet hand, scissors, etc.

INDUSTRY TIP

Review the Management of Health and Safety at Work Regulations 1999, which can be found on the HSE or .gov websites.

Injuries associated with tools and equipment

The most common injuries from the use of hand tools are:

- blows and cuts to the hands or other parts of the body
- eye injuries due to the projection of fragments or particles
- sprains due to very abrupt movements or strains
- contact with live conductors.

The principal causes of injury are:

- inappropriate use of the tools
- use of faulty or inappropriate tools
- use of poor-quality tools
- not using personal protection equipment
- forced postures.

Preventive measures are:

- use quality tools in accordance with the type of work being carried out
- ensure employees are trained in the correct use of tools
- use approved insulated hand tools (IEC 60900) when working in the vicinity of live parts
- use protective goggles or glasses (**BS EN 166**) in all cases and above all when there is a risk of projected particles
- use gloves to handle sharp tools
- periodically check tools (repair, sharpening, cleaning, etc.)
- periodically check the state of handles, insulating coverings, etc.
- store and/or transport tools in tool boxes.

Hand-held power tools (portable electrical equipment)

Almost 25% of all reportable accidents involve portable electrical equipment, the majority being caused by electric shock. Electrical equipment that is hand held or being handled when switched on presents a large degree of risk to the user if it does develop a fault.

Injuries associated with hand-held power tools

The principal causes of accidents are:

- use of damaged, defective or unsuitable equipment
- lack of effective maintenance
- misuse of equipment
- 'unauthorised' equipment (e.g. electric heaters, kettles, coffee percolators, electric fans) being used by employees
- use of power tools in a harsh environment (construction sites, etc.).

ACTIVITY

What is the purpose of a torque setting on an electric screwdriver?

HEALTH AND SAFETY

Always use correctly sharpened drills whether drilling wood, metal or building materials. Pushing harder is not an answer.



▲ Figure 7.4 Damaged transformer and poorly maintained equipment lead to a high risk of injury

Preventive measures are:

- correct selection and use of equipment
- ensure employees are trained in the correct use of tools
- effective maintenance regime for all power tools, including user checks
- keeping of test records following portable appliance testing
- removal of damaged equipment from use.

Personal protective equipment

Nearly all types of personal protective equipment (PPE) are covered by the Personal Protective Equipment at Work Regulations 1992 (PPE Regulations), with the exception being respiratory equipment.

PPE is defined in the PPE Regulations as 'all equipment (including clothing affording protection against the weather) which is intended to be worn or held by a person at work and which protects them against one or more risks to their health or safety'. Such equipment includes safety helmets, gloves, eye protection, high-visibility clothing, safety footwear and safety harnesses. Employers are responsible for providing, replacing and paying for PPE.

Hearing protection and respiratory protective equipment provided for most work situations are not covered by these regulations because other regulations apply to them. However, these items need to be compatible with any other PPE provided.

Procedures for recording unsafe situations

If, during the course of any work, an electrician discovers an unsafe situation which is an immediate threat to life, they must report it, in writing, to the responsible person or client immediately. If it is reasonable for them to

INDUSTRY TIP

Access Personal Protective Equipment at Work Regulations 1992, at the HSE website.

KEY TERMS

Responsible person: The person who is designated as the responsible person has delegated responsibility for certain aspects of a company's operational functions, such as fire safety, electrical operational safety or the day-to-day responsibility for controlling any identified risk, such as *Legionella* bacteria.

Competent person: In the context of the Electricity at Work Regulations, the term competent person is used to describe the person who possesses skill and knowledge of the electrical systems and who can understand the dangers that may arise from them. **BS 7671** now defines that person as Skilled (electrically).

HEALTH AND SAFETY

Always remember safe systems of work when undertaking fault location work as Regulation 14 of the EAWR places a strict prohibition on working on, or near, live conductors unless:

- it is unreasonable for the equipment to be dead
- it is reasonable for the work to take place on or near the live conductor and
- suitable precautions have been taken to prevent injury.

Always remember the SAFE ISOLATION.

immediately make the situation safe, they should do so. For example, if an electrician discovers a plastic light switch that is damaged and live parts can easily be touched, it is not unreasonable for the electrician to replace that switch whether the client agrees to pay for the repair/replacement or not.

VALUES AND BEHAVIOURS

When working as an electrician you will have a duty of care to report or make safe dangerous electrical situations. Situations that could eventually lead to danger should never be ignored.

Ultimately, it is the responsibility of the client or **responsible person** to decide if any repairs or replacements should be carried out. It is the duty of a **competent person** to advise them of the severity of any fault and what the statutory duty of the responsible person, or client, is and this must always be done in writing.

IMPROVE YOUR ENGLISH

Always ensure any written communication or record is clear, and sufficiently details the problem, particularly when concerning fault reporting, in order to keep all parties informed and safe.



REPORTING AND RECORDING OF FAULT DIAGNOSIS WORK

A fault is defined in **BS 7671** The IET Wiring Regulations as: 'A circuit condition in which current flows through an abnormal or unintended path. This may result from an insulation failure or a bridging of insulation.'

In addition to this, a fault could also be the term used to describe a defect, such as something not working properly (a faulty light fitting). It may not be faults that need correction work. Regular inspection and testing may also reveal non-compliances which may give rise to danger if not corrected. This is something that does not comply with BS 7671, such as poorly supported cables, and these, if not corrected, could fall, causing a danger or fault.

Procedures for recording information on electrical fault diagnosis

Electrical faults can happen at any time, and fault diagnosis and repair will often be undertaken in difficult circumstances. Whatever the circumstances, the information gathered during the fault diagnosis and after repair must be recorded and retained for future use.

The importance of recording this information is critical in order to make future decisions. As an example, if no records were kept for a socket outlet that has been damaged on several occasions, then repaired each time by different people, who is going to make the connection that perhaps the socket outlet is in the wrong place

or of the wrong type? If no records were kept, the last person to replace it would not know it had been replaced three times before. In other words, no pattern of failure is recognised.

When things get recorded, patterns of failure can be identified, and suitable action taken, such as re-siting the socket or installing a more robust metal socket. It may be that something really simple could be installed instead; perhaps a door stop that would stop a door hitting the socket and damaging it!

It is important to recognise the correct form to be used for each stage in the fault diagnosis and once found, the corrective work to make the installation safe and suitable.

Electrical Installation Condition Report

The Electrical Installation Condition Report (EICR) should only be used for reporting on the condition of an electrical installation. It is intended primarily for the person who is ordering the work (the client, duty holder or responsible person for the installation) and anyone subsequently involved in additional or remedial work. Its purpose is to confirm, so far as is reasonably practicable, whether or not the electrical installation is in a satisfactory condition for continued service.

As **BS 7671** is non-statutory there is no legislative requirement which stipulates that a duty holder, responsible person or person in control of the premises must have or retain any kind of electrical inspection report. However, from a liability and safety perspective, it is advisable and provides proof that the requirements of the EAWR are being met. Rented properties and certain types of public place, such as theatres, restaurants, cinemas, clubs and hotels, are generally required to have some kind of report for insurance purposes and an EICR (as recommended in BS 7671) fulfils this role. In the event of a death or serious injury, resulting from failure to maintain the electrical integrity of an installation, some form of legal action could result.

Every observation of a problem or concern relating to the safety of an installation, such as a fault, should be given an appropriate classification code selected from standard classification codes as follows.

- C1: Danger present. Risk of injury. Immediate remedial action required.
- C2: Potentially dangerous. Urgent remedial action required.
- C3: Improvement recommended.
- FI: Further investigation is required (although this is a code that would lead to the need for fault diagnosis work).

An Electrical Installation Condition Report will have attached to it a set of guidance notes explaining the purpose of the report. When an electrical fault has been diagnosed, identified and then repaired, **BS 7671** requires that the circuit, system or individual piece of equipment be inspected and tested and that functional tests should be carried out.

Depending on the extent of the fault and subsequent repair, either an Electrical Installation Certificate (EIC) or a Minor Electrical Installation Works Certificate (MEIWC) will be issued to the person requesting the work following successful rectification.

INDUSTRY TIP

Access a blank Electrical Installation Condition Report, at the IET Model Forms webpages

INDUSTRY TIP

Successful communication is key. While the Electrical Installation Condition Report must contain detailed technical language for reporting fault codes, you will need to consider ways of getting the information over to the client in a way they understand.

Electrical installations degrade with time due to physical damage to switches, sockets and other fittings, together with deterioration of cables. The severity of degradation is more pronounced in installations within buildings where:

- construction work is in progress
- adverse elements (such as corrosive chemicals or extreme temperatures) are involved
- maintenance has been poor.

To ensure the safety of everyone who may come into contact with an electrical installation, such as users or people who undertake maintenance, it is vital that the installation is regularly inspected and tested to identify any faults or potential failures. Regulation 4(2) of the EAWR (1989) states: 'As may be necessary to prevent danger, all systems shall be maintained so as to prevent, so far as reasonably practicable, such danger.'

Report codes

As its title suggests, the EICR is a report, not a certificate. It relates to an assessment of the in-service condition of an electrical installation against the requirements of the issue of **BS 7671** current at the time of the inspection, irrespective of the age of the installation.

The results, measurements and values taken during the inspection and testing are clearly recorded in a report and the associated schedules. Appropriate recommendations, if applicable, are made to rectify any damage, deterioration or defects, dangerous conditions and non-compliance with the requirements of the regulations that may give rise to danger.

The EICR contains 11 sections, which are identified alphabetically from A to K. Section K, 'Observations' has two columns to be completed. Observation(s) are entered in the first column. The second column requires a classification code (C1, C2 or C3) with reference to the observation(s).

In some situations, there are limitations to the inspection and testing. This could be something like:

- not able to gain access to a particular room as nobody has the keys
- not able to isolate a circuit as specialist equipment is connected that cannot be turned off
- not able to fully inspect something as it is in an inaccessible position needing specialist access equipment or in a built-in space in the building.

In these situations, a proper judgement on the severity of the fault cannot be made so an FI code is recorded, meaning Further Investigation is required without delay.

In the case of an FI code, the competent person would need to discuss with the client suitable times where this investigation work can be undertaken in order to fully investigate the problem.

HEALTH AND SAFETY

Remember, never attempt to investigate a fault where the circuit cannot be isolated. A fault can lead to very dangerous situations for anyone around that installation, especially you, the person investigating the fault.

ELECTRICAL INSTALLATION CONDITION REPORT	
SECTION A. DETAILS OF THE CLIENT / PERSON ORDERING THE REPORT	
Name	
Address	
.....	
SECTION B. REASON FOR PRODUCING THIS REPORT	
.....	
Date(s) on which inspection and testing was carried out	
SECTION C. DETAILS OF THE INSTALLATION WHICH IS THE SUBJECT OF THIS REPORT	
Occupier	
Address	
.....	
Description of premises	
Domestic <input type="checkbox"/> Commercial <input type="checkbox"/> Industrial <input type="checkbox"/> Other (include brief description) <input type="checkbox"/>	
Estimated age of wiring systemyears	
Evidence of additions / alterations Yes <input type="checkbox"/> No <input type="checkbox"/> Not apparent <input type="checkbox"/> If yes, estimate ageyears	
Installation records available? (Regulation 621.1) Yes <input type="checkbox"/> No <input type="checkbox"/> Date of last inspection (date)	
SECTION D. EXTENT AND LIMITATIONS OF INSPECTION AND TESTING	
Extent of the electrical installation covered by this report	
.....	
.....	
Agreed limitations including the reasons (see Regulation 634.2)	
.....	
Agreed with:	
Operational limitations including the reasons (see page no.....)	
.....	
The inspection and testing detailed in this report and accompanying schedules have been carried out in accordance with BS 7671: 2008 (IET Wiring Regulations) as amended to	
It should be noted that cables concealed within trunking and conduits, under floors, in roof spaces, and generally within the fabric of the building or underground, have not been inspected unless specifically agreed between the client and inspector prior to the inspection. An inspection should be made within an accessible roof space housing other electrical equipment.	
SECTION E. SUMMARY OF THE CONDITION OF THE INSTALLATION	
General condition of the installation (in terms of electrical safety)	
.....	
.....	
Overall assessment of the installation in terms of its suitability for continued use	
SATISFACTORY / UNSATISFACTORY* (Delete as appropriate)	
*An unsatisfactory assessment indicates that dangerous (code C1) and/or potentially dangerous (code C2) conditions have been identified.	
SECTION F. RECOMMENDATIONS	
Where the overall assessment of the suitability of the installation for continued use above is stated as UNSATISFACTORY, I / we recommend that any observations classified as 'Danger present' (code C1) or 'Potentially dangerous' (code C2) are acted upon as a matter of urgency.	
Investigation without delay is recommended for observations identified as 'Further investigation required' (code FI).	
Observations classified as 'Improvement recommended' (code C3) should be given due consideration.	
Subject to the necessary remedial action being taken, I / we recommend that the installation is further inspected and tested by(date)	
SECTION G. DECLARATION	
I/We, being the person(s) responsible for the inspection and testing of the electrical installation (as indicated by my/our signatures below), particulars of which are described above, having exercised reasonable skill and care when carrying out the inspection and testing, hereby declare that the information in this report, including the observations and the attached schedules, provides an accurate assessment of the condition of the electrical installation taking into account the stated extent and limitations in section D of this report.	
Inspected and tested by:	Report authorised for issue by:
Name (Capitals)	Name (Capitals)
Signature	Signature
For/on behalf of	For/on behalf of
Position	Position
Address	Address
Date	Date
SECTION H. SCHEDULE(S)	
.....inspection schedule(s) andschedule(s) of circuit details and test results are attached.	
The attached schedule(s) are part of this document and this report is valid only when they are attached to it.	

▲ Figure 7.5 Electrical Installation Condition Report

Code C1: danger present

This code indicates that there is a risk of injury and that immediate remedial action is required to remove the dangerous condition.

Code C1 allows those carrying out an inspection to report to the client or responsible person that a risk of injury exists, which could be, for example, accessible live conductors due to damage, poorly modified enclosures or removed maintenance panels. Incorrect polarity would also attract a Code C1 as it may allow conductive parts, not normally expected to be live, to become live.

A reported Code C1 warrants immediate action to be taken. This involves immediately informing the client or responsible person for the installation, both verbally and in writing, that a risk of injury exists. A detailed explanation of this risk should be recorded on the report, together with details of any verbal and written warnings. If possible, dangerous situations should be made safe or rectified before further work or inspections are carried out.

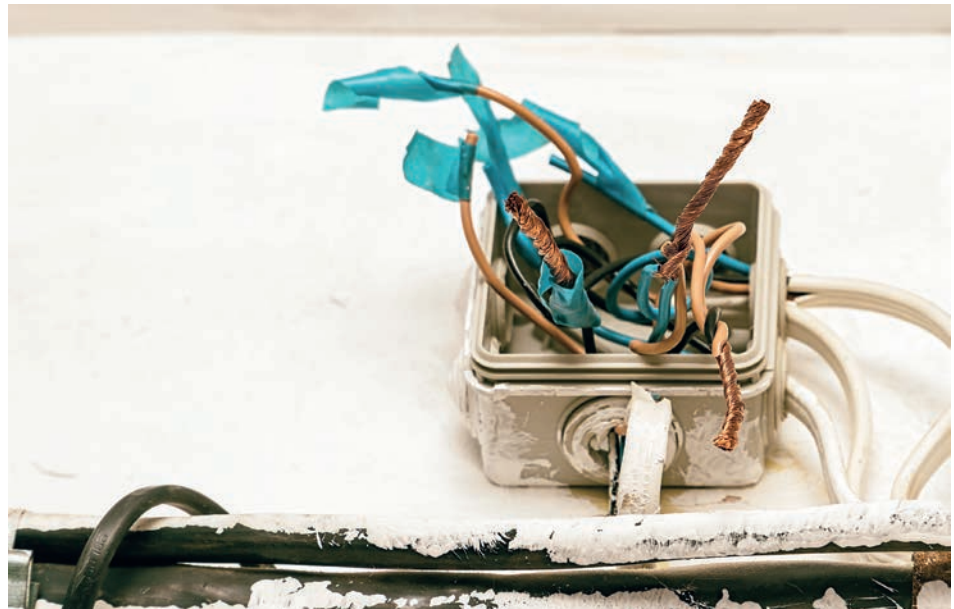

▲ Figure 7.6 Code C1: Dangerous wiring leaving exposed live parts

Wherever practicable, items classified as 'danger present' (C1) should be made safe on discovery. The duty holder or responsible person ordering the report should be advised of the action taken and on the necessary remedial work to be undertaken. If that is not practical you must take other appropriate action, such as switching off and isolating the affected parts of the installation to prevent danger.

There are two separate and distinct requirements for making a section of an electrical system safe when a Code C1 has been observed and recorded.

KEY TERM

Secure: Achieved by locking off with a safety lock, such as a lock with a unique key. The posting of a warning notice also serves to alert others to the isolation.

- Cutting/switching off the supply – depending on the equipment and the circumstances, this may be no more than carrying out normal functional switching (on/off) or emergency switching by means of a stop button or a trip switch.
- Isolation – this means the disconnection and separation of the electrical equipment from *'every source of electrical energy'* in such a way that this disconnection and separation is **secure**.



▲ Figure 7.7 Secure isolation using suitable locks and labelling

Alternatively, if an unsafe situation can be made good at a low cost or with ease, such as replacing a simple light switch or replacing a cover which has not been properly fitted, this is the preferred method. If a simple fix is all that is required, that doesn't remove the need to document the situation. All discoveries that are dangerous must be documented.

Code C2: potentially dangerous

This code indicates that urgent remedial action is required. The EICR should declare the nature of the problem, but not the remedial actions required.

The phrase 'potentially dangerous' indicates a risk of injury from contact with live parts following a 'sequence of events'. A sequence of events could mean that an individual would need to move, open or gain access to live parts when undertaking a daily task that would not normally be expected to give access to live parts.

An example of this would be an isolator with a damaged casing, in a locked cupboard. This might leave exposed live parts. But these could only be accessed with the use of access equipment, such as a specialist tool or key. An individual would need to gain access to the cupboard before coming into contact with live parts, but nevertheless the potential for risk of injury is high.

The lack of an adequate earthing arrangement for an installation, the use of utility pipes as the means of earthing or an undersized earthing conductor (in accordance with **BS 7671** Regulation 543.1.3) would also warrant a Code C2 because a primary fault would be needed in order for these scenarios to become potentially dangerous. Other examples include high earth fault loop impedance values leading to increased disconnection times or loose or disconnected bonding clamps on pipes.

For items classified as 'potentially dangerous' (C2), the safety of those using the installation may be at risk and it is recommended that a competent person undertakes any necessary remedial work as a matter of urgency.

ACTIVITY

Consider situations that would need a C2 code.

If this potentially dangerous situation can be rectified by an addition or a simple alteration to the installation, the client will probably request that this is carried out. It should be remembered that this is not part of the initial agreement. If the work does not involve major system changes, such as the installation of a new circuit, then a MEIWC should be issued. Remember an EIC is to be used only for the initial certification of a new installation or for an alteration or addition to an existing installation where new circuits have been introduced.

Code C3: improvement recommended

This code implies that, while the installation may not comply with the current edition of the regulations, it does comply with a previous edition and is deemed safe, although improvements could be made. An example could be where an installation not modified in recent years has cables concealed in a wall that are not provided with additional protection by an RCD.

For items classified as Code C3, 'improvement recommended', the inspector has found some problems that are not immediate risks but may become risks if not improved. One example may be that the inspection has found circuits that have not got 'additional protection', as required by current regulations. This isn't necessarily unsafe but could be improved.

For safety reasons, the electrical installation will need to be re-inspected at appropriate intervals by a competent person. The recommended date by which the next inspection is due should be included in the report, under 'Recommendations', and on a label near to the consumer unit or distribution board.

The time period to the next inspection is a decision made by the inspector. If an inspector found several C3 non-compliances, this duration would be shorter than finding one C3.

Actions to be taken in response to Report Codes issued

An EICR is intended primarily for the person who is ordering the work to be undertaken (the client, duty holder or responsible person for the installation) and anyone subsequently involved in additional or remedial work or additional inspections to confirm, so far as reasonably practicable, whether or not the electrical installation is in a satisfactory condition for continued service.

On completion of the inspection, the client, duty holder or responsible person ordering the work should receive the original report and the inspector should retain a duplicate copy. The original report should be retained in a safe place and be made available to any person inspecting or undertaking work on the electrical installation in the future. If the property is vacated, the report will provide the new owner or occupier with details of the condition of the electrical installation at the time the report was issued.

IMPROVE YOUR ENGLISH



Communicating the results of an inspection is very important, and in some cases, where unsafe situations have been found, the report should be backed up by a detailed letter or email detailing the responsibility of the person ordering the work to have those items rectified immediately.

FAULT DIAGNOSIS PROCEDURES

Fault diagnosis is one of the highest risk tasks when working on electrical installations due to the unknown issues that could be causing the fault. As a result, persons undertaking fault diagnosis and location work must consider the following:

- Hazards associated with fault diagnosis and minimising those hazards
- Safe working and logical procedures
- Understanding the types of faults
- Preparation and use of test instruments
- Interpreting results and data.

Hazards associated with fault diagnosis

The Electricity at Work Regulations 1989 (EAWR) require those in control of part or all of an electrical system to ensure that it is safe to use and that it is maintained in a safe condition. The process of identifying and rectifying faults will inevitably involve exposure to some hazards and these must be dealt with in accordance with the requirements of the EAWR.

Electrical injuries are the most likely hazard and the following may occur due to contact with electricity:

- electric shock
- electrical burns
- loss of muscle control
- fires arising from electrical causes
- arcing and explosion.

Electric shock

Electric shock may arise either from direct contact with a live part during the testing process or, indirectly, by contact with an exposed conductive part that has become live as a result of a fault condition, such as:

- contact with live electrical parts if basic protection has been removed
- a cracked equipment case causing 'tracking' from internal live parts to the external surface
- poor installation practice exposing bare live conductors at terminations
- exposure to static electricity from industrial processes or something as simple as walking on a carpet.

The magnitude (size) and duration of the shock current are the two most significant factors determining the severity of an electric shock. The magnitude of the shock current depends on the contact voltage and impedance (electrical resistance) of the shock path. A possible shock path always exists through ground contact (e.g. through a hand-to-feet route); in this case the shock path impedance is the body impedance plus any external impedance. A more dangerous situation is a hand-to-hand shock path, when one hand is in contact with an exposed conductive part, such as an earthed metal equipment case, while the other simultaneously touches a live part. In this case, the current will be limited only by the body impedance.

INDUSTRY TIP

At 230 V the average person has a body impedance of approximately 1300 Ω . At mains voltage and frequency (230 V, 50 Hz), currents as low as 50 milliamps (0.05 A) can prove fatal, particularly if flowing through the body for a few seconds.

Remember, impedance is like resistance, but impedance can change with frequency. See Chapter 2, pages 89–90.

As the voltage increases, so the body impedance decreases – this increases the shock current. When the voltage decreases the body impedance increases, which reduces the shock current.

Systems where voltages are below 50 V AC or 120 V DC (extra-low voltage) reduce the risk of electric shock to a low level. If the system energy levels are low, then arcing is unlikely to cause burns.

Electric burns

Electric burn injury may arise due to:

- the passage of shock current through the body, particularly if at high voltage
- exposure to high-frequency radiation, e.g. from radio transmission antennas.

An electrical burn may not show on the skin at all or may appear minor, but the damage can extend deep into the tissues beneath the skin. Medical advice should always be sought if an electrical burn is sustained.

Loss of muscle control

People who experience an electric shock often get painful muscle spasms that are strong enough to break bones or dislocate joints. This loss of muscle control may mean that the person cannot let go to escape the electric shock. Alternatively, the person may fall if they are working at height or be thrown into nearby machinery and structures.

Direct current (DC) is particularly high risk as the current locks a person's muscle, meaning they cannot let go if they are holding a live conductive part.

Fires arising from electrical causes

In 2016/17 more than 10% of fires in domestic premises had electricity distribution as the factor in their cause. The principal causes of fires arising from electricity are wiring with defects such as insulation failure, the overloading of switches and isolators or conductors, lack of electrical protection, poor connections and the incorrect storage of flammable materials.

Arcing and explosion

This frequently occurs due to short-circuit flashover accidentally caused while working on live equipment (either intentionally or unintentionally). Arcing generates UV radiation, causing severe sunburn; molten metal particles are also likely to be ejected onto exposed skin surfaces.

There are two main electrical causes of explosion:

- short circuit – due to an equipment fault
- ignition of flammable vapours or liquids – caused by sparks or high surface temperatures.

Minimising hazards of fault diagnosis

Understanding the measures used to minimise the hazards of fault diagnosis is essential, not just for the safety of the inspector, but also for protecting others and the electrical equipment.

HEALTH AND SAFETY

For the latest information relating to fires in domestic premises, research the Home Office's Detailed analysis of fires attended by fire and rescue services.

Isolation and switching of supply

The preparation of electrical equipment for fault diagnosis and repair purposes often requires effective disconnection from all live supplies and a means for securing that disconnection, for example, by locking off with a suitable lock and single key. There is an important distinction between switching and isolation.

Switching is cutting off the supply while isolation is the secure disconnection and separation from all sources of electrical energy. A variety of control devices is available for switching, isolation or a combination of these functions, some incorporating protective devices. Before starting work on a piece of isolated equipment, checks should be made, using an approved testing device, to ensure that the circuit is dead.

There are also secondary hazards, detailed below, associated with electrical testing that must be considered when risk assessments and a safe work practice document are being prepared.

Minimising hazards of lone working

Fault diagnosis, which may require some form of live electrical work, is often undertaken by people working alone and without close or direct supervision. There is no specific requirement contained in the Electricity at Work Regulations for two people to be present in 'livework' situations. It is the responsibility of the duty holder to assess the need for a second person in terms of the nature of the danger and other precautionary measures to be adopted (such as role planning and relevant training). If a second person is *not* present, consideration must be given to special procedures for the lone worker, such as:

- making sure that every site visit is recorded in a visitor log book
- keeping in contact with the employer by making regular telephone calls
- signing out when leaving the site for any reason
- making contact with the site owner on returning to site, to confirm that there have been no material changes to the system since the last visit.

It is likely that an electrician visiting a site for fault rectification purposes will be required to undergo some form of induction training which will explain the requirement to observe site-specific elements appropriate to their own work and/or site-specific activities, such as:

- site hazards and risks, e.g. open excavations, presence of overhead power lines, confined spaces and hazardous areas
- fire risks and site fire procedures
- areas of work that will require specific authorisation to proceed, such as a permit to work
- restricted areas and the reasons for the control measures in place.

Minimising hazards from static electricity

Static electricity is produced by the build-up of electrons in weak electrical conductors or insulating materials. These materials may be gaseous, liquid or solid and may include flammable liquids, powders, plastic films and granules.

KEY TERM

Livework: Working on or near live parts.

A simple example of static electricity is a person walking across a carpeted floor, who builds up a static charge because of the friction of their shoes on the carpet. When the person touches an object that is either uncharged or that has an opposite charge, a short pulse of very high-voltage static charge is released quickly. This can cause damage to sensitive circuitry in computers, laptops and communication systems. Anti-static carpet sprays can be used to combat this problem.

Large static charges may develop on drive belts between motors and machinery, such as those involving laminate manufacturing processes or large rolls of paper for toilet tissue or kitchen roll running at high speeds. If not diverted through proper earthing, the built-up static charges may discharge suddenly and cause damage to electronic equipment, such as proximity switches and programmable logic controllers. Earthed anti-static strips, which look similar to tinsel, can be strategically positioned to continuously discharge these unwanted voltages.

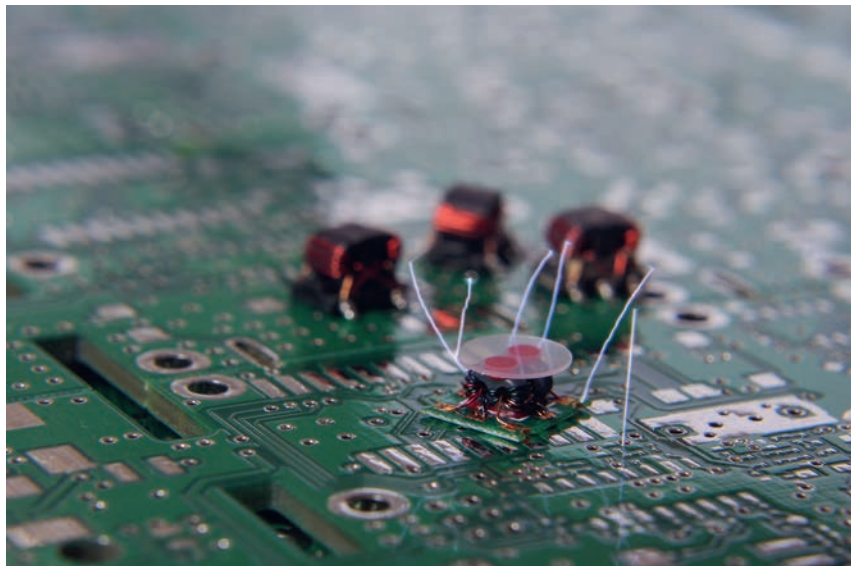

▲ Figure 7.8 Static sparks can damage electronics components

In areas containing explosive materials, great care must be taken to prevent static discharges, since a spark could set off a violent explosion. The use of large-diameter pipes for the transfer of liquids reduces the flow rate and, hence, the build-up of static charge. Airborne fibres, dust or flecks of paper – such as those produced in industrial processes – should be removed at source and not be allowed to accumulate as this may create a fire risk if static is likely. The static effect is increased in environments with low humidity and in buildings with air conditioning and high levels of heating, such as computer suites, and this should be considered when undertaking electrical work in such areas.

Minimising hazards from fibre-optic cabling

As more fibre-optic cable systems are introduced into installations, the maintenance and fault-finding demands increase. Probably the greatest hazard to deal with, for approved electricians, is fibre-optic cable's benign appearance. It does not carry electricity, so there is no electrocution risk; it isn't a source of heat or combustion so there is no fire risk; and it is not possible to know when it is operating.

Energy is transferred along fibre-optic cables as digital pulses of laser light and, therefore, direct eye contact with the light should be avoided. However, damage to the eye caused by looking into a damaged fibre-optic cable is rare as the broken surface of the cable tends to scatter the light coming through it.

A more serious hazard of optical-fibre work comes from the fibres themselves. Fibres are pieces of optical glass which, like any piece or sliver of glass, can cause injury. Hazards arise when cables are opened and fibres penetrate the hands or are transferred to the respiratory or alimentary system. Therefore, suitable PPE (such as gloves and face masks) should be used when working with fibre-optic cabling.

Fibre-optic cables have a similar appearance to steel wire armour cables (SWA) but are much lighter. They should be installed in the same way and given a similar level of protection as steel wire armour cables. Fibre-optic terminations should always be carried out in accordance with the manufacturer's instructions.

Minimising hazards from electronic devices

The use of electronic circuits in all types of electrical equipment is now commonplace, with components being found in motor starting equipment, control circuits, emergency lighting, discharge lighting, intruder alarms, special-effect lighting and dimmer switches, and domestic appliances. Electrical installations usually operate at currents in excess of 1 A and up to many hundreds of amperes; all electronic components and circuits are low voltage and usually operate in mA or μA . Therefore, this fact must be considered when the choice of electrical test equipment is made.

The working voltage of a standard insulation resistance tester (250 V/500 V) may cause damage to any of the electronic devices described above, if not rated for this voltage. When carrying out insulation resistance tests as part of a prescribed test, or after fault repair, all electronic devices must be disconnected. Should resistance measurements be required on electronic circuits and components, a battery-operated ohmmeter with high impedance must be used.

Minimising hazards from high-frequency or capacitive circuits

Capacitors that are used in fluorescent fittings and single-phase motors are a potential source of electric shock arising from:

- the discharge of electrical energy retained by the capacitor unit(s) after they have been isolated
- inadequate precautions to guard against electric shock as a result of any charged conductors or associated fittings
- charged capacitors that are inadequately short circuited
- equipment retaining or regaining a charge.

Live working is to be avoided where possible, but any equipment containing a capacitor must be assumed to be live or charged until it is proven, beyond any doubt, that the circuits are dead and the capacitors are discharged and are unable to recharge.



▲ Figure 7.9 Electricians should use appropriate PPE when dealing with fibre-optic cables

Minimising hazards from storage batteries

Batteries are used to store electrical energy. Their ability to provide instant output makes them a regular source of standby power for emergency lighting, emergency trip coils and uninterruptable power supplies (UPS) at computer, data storage and telecommunication facilities, for example. They can prove invaluable for maintaining supplies where a supply interruption could cause business issues. There is, however, risk attached to these larger battery systems which, if used incorrectly, can be dangerous and can cause explosions.

There are two main classes of battery.

- Lead–acid batteries are the most common large-capacity rechargeable batteries. They are fitted extensively in UPS of computer and communication facilities, and process and machinery control systems.
- Alkaline rechargeable batteries, such as nickel–cadmium, nickel–metal hydride and lithium ion, are widely used in small items, such as laptop computers, but large-capacity versions of these cells are now being used in UPS applications.

The two main hazards from batteries are described below.

- Chemical: lead–acid batteries are usually filled with electrolytes, such as sulphuric acid or potassium hydroxide. These very corrosive chemicals can permanently damage the eyes and produce serious chemical burns to the skin. If acid gets into the eyes, they should be flushed immediately with water for 15 minutes, and prompt medical attention should be sought. If acid gets on the skin, the affected area should immediately be rinsed with large amounts of water and prompt medical attention should be sought if the chemical burn appears serious. Emergency wash stations should be located near lead–acid battery storage and charging areas. Under severe overcharge conditions, hydrogen gas may be vented from lead–acid batteries and this may form an explosive mixture with air if the concentration exceeds 3.8% by volume. Adequate ventilation and correct charging arrangements should always be observed.
- Electrical: batteries contain a lot of stored energy. Under certain circumstances, this energy may be released very quickly and unexpectedly. This can happen when the terminals are short circuited, e.g. with an uninsulated metal spanner or screwdriver. When this happens, a large amount of electricity flows through the metal object, making it very hot, very quickly. If the battery explodes, the resulting shower of molten metal and plastic can cause serious burns and can ignite any explosive gases present around the battery. The short circuit may also produce ultraviolet (UV) light which can damage the eyes.



▲ Figure 7.10 Batteries can explode if used incorrectly



▲ Figure 7.11 Storage batteries

Most batteries produce quite low voltages, and so there is little risk of direct electric shock. However, as some large battery combinations produce more than 120 V DC precautions should be taken to protect users and those working in the vicinity of these installations.

- Ensure that live conductors are effectively insulated or protected.
- Keep metal tools and jewellery away from the battery.
- Post suitable notices and labels warning of the danger.
- Control access to areas where dangerous voltages are present.
- Provide effective ventilation to stop dangerous levels of hydrogen and air or oxygen accumulating in the charging area.

Minimising hazards from information and technology (IT) equipment

All modern offices contain computers that are operated as standalone units or networked (linked together). Most computer systems are sensitive to variations in the mains supply, which can be caused by external mains switching operations, faults on adjacent electricity distribution network circuits, which cause a voltage rise, and industrial processes such as induction furnaces and electric arc welding. These system disturbances are often well within the electricity supply companies' statutory voltage limits but may be sufficient to cause computers to crash.

To avoid the effects of this system 'noise', computer networks are normally provided with a clean supply, including a 'clean earth'. This is obtained by taking the supply to the computer network from a point as close as possible to the supply intake position of the building. The fitting of noise suppressors or noise filters provides additional protection to the computer system. If a production process disruption or data loss is a serious business risk, an uninterruptable power supply (UPS) is a sensible solution.

INDUSTRY TIP

If battery cables are removed for any reason, ensure that they are clearly marked 'positive' and 'negative' so that they are reconnected with the correct polarity.

A UPS provides emergency power by supplying power from a separate source (normally batteries) when the supply from the local supply company is unavailable. It differs from an auxiliary or emergency power system or standby generator, as these do not provide instant protection from a temporary power interruption. A UPS can be used to provide uninterrupted power to equipment, typically for 5 to 15 minutes, until an auxiliary power supply can be turned on, mains power restored, or equipment safely shut down. UPS units come in sizes ranging from units that will back up a single computer without monitor (around 200 W) to units that will power entire data centres or buildings (several megawatts (MW)).



▲ Figure 7.12 Many single computers and installations have uninterruptable power supplies, so that they may be live even if the mains power is off

HEALTH AND SAFETY

Proving dead at the point of work is the most important part of ensuring a safe system of work. If the isolation has been incorrectly applied, the act of proving dead should identify that the circuit is, in fact, still live. A proper procedure, using a suitable proving device, is therefore essential.

All of the above features are designed to keep power supplies constant for IT and similar equipment to prevent data loss, but fault diagnosis can impact on this requirement. Before any fault diagnosis is carried out, confirm whether the standby or UPS will present a danger to the electrician undertaking the work. Remember, the preferred method of work is with the system dead and, as such, it must be isolated from all points of supply, including auxiliary circuits, and dual or alternative supplies, such as UPS or a standby generator (that may be set for automatic start-up).

If it is necessary to isolate the computer supply network, permission must be sought from the duty holder or the responsible person for the computer systems to avoid any loss of data or damage to the computers. However, standby or UPS back-up systems can also be used to avoid IT shutdowns during fault diagnosis and testing by maintaining supplies to critical areas.

Minimising hazards from hazardous areas

Although all the hazards discussed above could be considered to give rise to hazardous areas, a 'hazardous area' is defined in the Dangerous Substances and Explosive Atmospheres Regulations 2002 (DSEAR) as 'any place in which

an explosive atmosphere may occur in quantities such as to require special precautions to protect the safety of workers'. These regulations provide a specific legal requirement to carry out a hazardous area study and document the conclusions in the form of zones. In the context of the definition, 'special precautions' relate to the construction, installation and use of apparatus, as given in **BS EN 60079-10**.

Hazardous areas are classified into zones based on an assessment of the frequency of the occurrence and duration of an explosive gas atmosphere, as follows:

- Zone 0: an area in which an explosive gas atmosphere is present continuously or for long periods
- Zone 1: an area in which an explosive gas atmosphere is likely to occur in normal operation
- Zone 2: an area in which an explosive gas atmosphere is not likely to occur in normal operation and, if it occurs, will only exist for a short time.

Most volatile materials (those that disperse readily in air) only form explosive mixtures between certain concentration limits. The **flash point** of a volatile material is the lowest temperature at which it can vaporise to form an ignitable mixture in air; flash point refers to both **flammable** liquids and **combustible** liquids.

The primary risk associated with combustible gases and vapours is the possibility of an explosion. Explosion, like fire, requires three elements: fuel, oxygen and an ignition source. Each combustible gas or vapour will ignite only within a specific range of fuel/oxygen mixtures.

Too little or too much gas and the gas or vapour will not ignite. These conditions are defined by the lower explosive limit (LEL) and the upper explosive limit (UEL). Any amount of gas between the two limits is explosive.

Sources of ignition should be effectively controlled in all hazardous areas by a combination of design measures and systems of work. All electrical equipment must carry the appropriate markings if the integrity of the wiring system is to be maintained. A luminaire to IP 65 (this International Protection code means the fitting is dust-tight and water-jet protected) is an example of equipment used in hazardous areas.

When any work is to be undertaken on electrical equipment in a hazardous area, the following procedures must be observed:

- a written safe work procedure (PTW system) that includes control of activities which may cause sparks, hot surfaces or naked flames, should be in place
- control of the working area with signs and barriers
- use of appropriate PPE
- only authorised and competent people to be engaged in the work activity
- only approved tools and equipment to be used
- prohibition of smoking, use of matches and lighters.

INDUSTRY TIP

Read more on the Dangerous Substances and Explosive Atmospheres Regulations 2002, at: www.hse.gov.uk/fireandexplosion/dsear.htm

KEY TERMS

Flash point: Refers to liquids that are flammable. Gases are ignitable and we use LEL and UEL to define limits when a gas will ignite or explode.

Flammability: A measure of how easy it is for something to burn or ignite, causing a fire.

Combustion: A chemical reaction between fuel, oxygen and an ignition source (e.g. matches). The fuel can be a gas, a liquid or a solid, such as wood or paper.

If work is to be undertaken in a hazardous area, the hazards and the requirements to be observed will normally be explained during the site induction process.

Safe working and logical procedures

The possibility of touching live parts is increased during fault finding and repair, when conductors at dangerous voltages are often exposed. This risk can be reduced if work is done while the equipment is isolated from any dangerous source of electrical supply. However, this may not always be possible and, if this is the case, procedures should be followed to prevent danger.

Planning and agreeing procedures

Before fault rectification is carried out, the safe working arrangements must be discussed and agreed with the client and/or the duty holder (or responsible person for the installation) in a clear, concise and courteous manner. The procedure must be a planned activity as it will almost certainly affect people who work or live in the premises where the installation is being tested. This ensures that everyone who is concerned with the work understands what actions need to be taken, such as:

- which areas of the installation may be subject to disconnection
- anticipated disruption times
- who might be affected by the work
- health and safety requirements for the site
- which area will have restricted access
- whether temporary supplies will be required while the fault repair is underway
- the agreement reached on who has authority for the repair.

It may be that a specific person has responsibility for the safe isolation of a particular section of an installation, in which case that person should be identified and the isolation arrangements agreed.

VALUES AND BEHAVIOURS

Entering into dialogue with the client, before work commences, will minimise the potential for unforeseen events and foster good customer relations.

For example, in an office block where the electrical installation is complex and provides supplies to many different tenants located on a number of floors, the safe isolation of a sub-circuit for testing purposes may require a larger portion of the installation to be turned off initially. To achieve this with minimal disruption, an agreement must be reached between the competent person tasked to carry out the work and the person responsible for the installations affected. This responsible person may be the office manager, the designated electrical engineer for the site or, in some cases, the landlord of the building.



▲ Figure 7.13 Isolation of an installation should be part of a planned and agreed procedure

IMPROVE YOUR ENGLISH



Everyone involved in the work (e.g. client, electrician and those in the workplace) has a responsibility for their own health and safety and that of others who may be affected by the work. Communication between all parties will ensure compliance with the respective health and safety requirements.

A logical approach for locating electrical faults

Locating faults that occur on an electrical system requires a logical approach. This approach includes:

- identifying the symptoms
- collecting and analysing data
- using information, such as drawings, certificates, instructions
- checking maintenance records
- using experience
- inspecting, checking and testing.

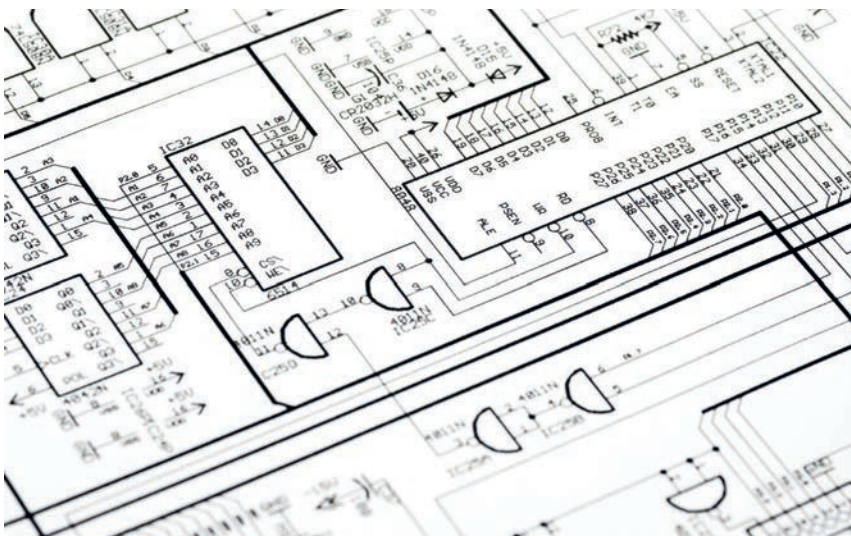

▲ Figure 7.14 Detailed information helps to diagnose faults

Information

In order to follow the logical approach to safe working as detailed above, the approved electrician must have:

- an approved safe working procedure or method statement, including a risk assessment
- a thorough knowledge and understanding of the electrical installation and electrical equipment (including access to site-specific circuit diagrams and drawings, manufacturers' information and operating instructions, design data, copies of previous Schedules of Inspection or certificates, installation specification and maintenance records)
- information relating to the fault, including any available knowledge of events leading up to the fault (such as unusual smells or observations); this can be obtained from users, the duty holder or the responsible person
- details of personnel relevant to the operation of the installation. If a fault has occurred, it is likely that users of the system will have reported a loss of supply or changes in the way the system operates; they will probably be able to identify the areas affected. Determining which protective device has operated (main circuit breaker, individual circuit breaker or residual current device) will narrow the search area and a flow diagram can often assist in this process.

Questions to ask users include the following.

- Which parts of the system are without supply – the whole installation or a particular item of equipment?
- Is the failure a permanent problem or does it only happen at certain times or on certain days?
- What are the events that led up to the fault occurring?

Visual inspection

A visual inspection is a quick way of identifying defects, damage or deterioration of the electrical installation. Although this check is commonly called a visual inspection, other senses such as smell, touch and hearing are also used. Touch can be used to test conductors to see if they are loose at joints and connections, and smell can be used to identify overheating of thermoplastic material caused by a high resistance fault. Hearing can be used to detect arcing at a loose termination.

When conducting a visual inspection, you should consider:

- joints and connections – are conductors loose or is a connection missing?
- conductors – do they show signs of overheating?
- flexible cables and cords – are there signs of exposed insulation or conductors?
- switching devices – any signs of overheating?
- protective devices – have they operated?
- enclosures and mechanical protection – any signs of overheating or physical damage?

Check the supply voltage

When checking the supply voltage, you should consider:

- is the complete system, together with all circuits, dead?
- is a particular section of the installation dead?
- has an individual piece of equipment failed?

Use an approved voltage tester to check for a supply voltage. If there is no incoming supply from the distribution network operator (DNO), this may be due to a main fuse failure, circuit breaker operation or a fault on the DNO network. It will be necessary to contact the distribution company to effect a repair.

INDUSTRY TIP

When you dismantle equipment make sure you label, if necessary, all parts and store them securely.



▲ Figure 7.15 Checking the supply voltage

Check the protective devices

When checking the protective devices, you should consider:

- has the main circuit breaker tripped?
- is the system overloaded; have unauthorised items of equipment been connected to the system?
- is the wiring in the distribution board damaged in some way, or is there a short circuit somewhere in the system between live and neutral conductors?

Common causes of electrical faults

Knowing some of the common causes of faults will enable a person undertaking fault diagnosis work to work more efficiently and logically.

Many faults are caused through:

- poor system design
- incorrect implementation of the designer's specification
- a poor standard of installation workmanship
- poor maintenance or neglect of equipment or installation
- misuse, abuse or deliberate ill-treatment of equipment.

Poor system design

The proper specification and design of electrical systems and equipment is fundamental to the safe operation of installations. The designer of a low-voltage system will need a good working knowledge of **BS 7671** The IET Wiring Regulations, associated IET Guidance Notes and codes of practice, technical and equipment standards. They should also understand the duties imposed by Regulations 4 to 15 of the EAWR and the technical reasons behind them.

In addition, designers will want the best in terms of equipment but sometimes budgets mean cheaper equipment is used, leading to decreased reliability.

Failure to implement the designer's specification correctly

However good the design of a system, it has to be installed correctly to function as intended. Those concerned with installing the system must be competent to ensure that the designer's specification is correctly implemented and all workmanship is to a high standard.

Poor standard of installation workmanship

Typical areas of poor installation practice are:

- poor termination of conductors, which creates overheating due to poor electrical contact
- loose bushings and couplings, which may lead to poor earth continuity and risk of shock
- use of incorrectly sized conductors, leading to overheating
- cable damage that occurs when drawing in cables
- heavily populated trunking or conduit, leading to overheating
- incorrect connections at components, which may lead to crossed polarity (so that a circuit remains live although the protective device has operated).

Those concerned with installation work need to know not only *how* to do a job, but *why* it is important to do it in the specified way.

Misuse of equipment

EAW Regulation 4(3) requires that: 'every work activity, including operation, use and maintenance of a system and work near a system, shall be carried out in such a manner as not to give rise, so far as is reasonably practicable, to danger and users (the duty holder) have a responsibility to use equipment in the manner for which it was intended'. Deliberate or unintentional misuse, such as overloading a radial circuit supplying socket outlets with too many electric heaters, could be seen as misuse.

Abuse or deliberate ill-treatment of equipment, such as removal of barriers or covers, may result in a short circuit because of contact between live conductors.

Understanding common faults

An electrical fault can reveal itself in a number of ways or in a combination of those ways, for example:

- complete loss of power throughout the whole installation
- partial or localised loss of power
- failure of an individual component.

Failure of an individual component

Faults in components such as switches, contactors, time switches and photo electric cells may result in particular circuits not operating as was intended. For example, heaters that are programmed to operate via a time switch can only be turned off by operation of the protective device.

Total failure of a piece of equipment

An example might be the failure of a heating element in a fire or shower, resulting in an earth fault or short circuit.

Insulation failure

An insulation fault can allow current leakage. As insulation ages, its insulating properties and performance deteriorates; this is accelerated in harsh environments, such as those with temperature extremes and/or chemical contamination. This deterioration can result in dangerous conditions for people and poor reliability in installations. It is important to recognise this deterioration so that corrective steps can be taken.

Excess current

If excess current is drawn by a circuit, protective devices will operate frequently. This could be caused by too many items of equipment being connected at the same time.

Short circuits

These occur when two or more components, which would normally be separated by insulation or barriers, come into contact with each other. For example, in an overload condition the circuit conductors are carrying more current than the manufacturer's design specification allows and, if this is allowed to continue indefinitely, the conductors will become very hot, causing deterioration of the electrical insulation surrounding the live conductors. This may eventually lead to breakdown of the insulation and a short circuit. In this overload situation, it is likely that the protective device, if specified correctly, will operate before a short-circuit condition is reached. Continual operation of a protective device should be investigated immediately, by isolating the circuit or carrying out an insulation resistance test, or by using a clamp meter or clip-on meter to check load readings.

Open circuits

An open circuit generally occurs when there is a break in the circuit. This could be the result of a broken conductor, a loose connection caused by excessive mechanical stress or a component that has failed due to age, damage, overloading, suitability for continued use and overheating.

Transient overvoltage

This is caused by heavy current switching and distribution network operator (DNO) system faults. Occasionally, large internal loads may cause such transient overvoltages.

The designer of a system must ensure that all system components are selected according to their intended use and are appropriately rated. Two main factors must be considered:

INDUSTRY TIP

More information on the CENELEC harmonised documents can be accessed at the CENELEC website, www.cenelec.eu

- switchgear, fuse gear and cables must be of adequate rating to carry both normal and any likely fault current safely
- the equipment should meet appropriate British, European or International Standards or CENELEC harmonised documents in order to withstand prospective fault conditions in the system.

However, design work does not cater for abnormal transient voltages caused by DNO faults on the supply network, heavy current switching that causes voltage drops, lightning strikes on overhead line conductors, electronic equipment and earth fault voltages. In some installations, such as IT networks, where transient voltages can cause problems, additional measures are included. Filters added to IT networks can suppress transient voltages and provide stabilised voltage levels.

High-resistance faults

These faults usually occur in a circuit where a cable or conductor is poorly joined in an accessory, such as a socket outlet, switch, light fitting, or junction box. The most common cause is simply a loose screw terminal connection, because the connection was not made sufficiently well in the first place, debris is present in the connection (e.g. pieces of stripped insulation), or it might be that the connection has become loose over time. Connections can work loose through the normal thermal cycling of a circuit. If a circuit routinely carries a significant proportion of its maximum design current, the cable will be subject to repeated heating and cooling cycles. This can result in expansion and contraction, which can loosen the terminal screws. Vibration can also affect joints and connections, and that is why connections for generators need to be crimped or brazed.

Where common faults are found

The following list is not exhaustive but it highlights the major areas where faults may occur.

Wiring systems

Wiring faults do occur in low-voltage systems but cable damage is not a common occurrence if the installation has been constructed in accordance with Chapter 52 of **BS 7671** The IET Wiring Regulations. However, if the installation has not been constructed to a high standard, damage may occur and a latent fault may exist, causing a failure at a later date. PVC-insulated and sheathed wiring is extensively used for wiring in domestic and light industrial installations, and the very act of installing cable runs can result in mechanical damage to the cable due to impact, abrasion, compression or penetration (which must be minimised at all times).

Where cables have to be turned or bent, the radius should be such that it does not damage the conductors. Where cables are installed in walls behind plaster or in a stud wall, mechanical protection is only required if the depth of the cable is less than 50 mm, or if they are not placed within accepted zones that are 150 mm wide around wall edges and ceiling–wall joints, or if the cables are

not run horizontally or vertically to an accessory point. If it is not possible to provide such protection and the installation is used by people with no technical background, additional protection must be provided by the installation of a residual current device.

When designers calculate the conductor sizes for installations, based on load factors, they also specify how the cables should be installed. Any deviation from the specification could have an adverse effect – cable current-carrying capacities will be reduced by such factors as grouping, surrounding the cables with thermal insulation and siting the cables in a hot environment that will cause overheating. Bear in mind that this could take place after the installation was originally commissioned. Poor installation practice could also result in cables being subjected to compression, pinching or abrasive damage.



▲ Figure 7.16 Thorough test and inspection at the initial verification stage can minimise faults occurring by picking up installation errors

Surface cabling in industrial workplaces, or where there is movement of materials or goods, must be protected from mechanical damage. This may be achieved by the use of cables incorporating mechanical protection (such as steel wire armoured or mineral-insulated cable) or by the installation of cables in steel conduit or trunking, or by locating the cables where they will not be liable to damage.

Poor terminations will result in localised heating (and an increased fire risk) and progressive deterioration of the joint or termination. There will be evidence of pitting, arcing, carbon build-up or corrosion that could lead to eventual failure and an open circuit. Loose connections developing into a short circuit are often accompanied by audible sounds such as 'crackling' or 'fizzing' and by referred problems in adjacent parts of the installation.

HEALTH AND SAFETY

Wiring faults often occur where cables are jointed or terminated. A termination is a connection between a conductor and other equipment (e.g. distribution boards or fixed appliances), or an accessory. Connections between conductors are usually termed 'joints'. A poorly constructed joint or termination may give rise to arcing with the passage of load current.

When a fault occurs elsewhere on an associated part of an electrical system, a poor joint or termination may constitute a hazard by limiting the flow of fault current, thereby causing delayed operation of the circuit protective device. In an extreme case, the passage of high fault current may cause the defective joint to burn into an open-circuit fault before the circuit protective device has time to operate, with the result that the original fault remains uncleared. This is particularly hazardous in the case of an earth fault, since exposed conductive parts may become and remain live at the system voltage, giving an increased risk of electric shock.

Equipment and accessories

Faults can also occur in equipment and accessories, such as switches, sockets, control equipment, motor contactors and electric appliances or at the point of connection with electronic equipment. Contacts that make and break a circuit are a potential source of failure, depending on the amount of operation they are subjected to. Socket outlets and isolating switches that control fans in kitchens or bathrooms, or showers in bathrooms, that are subjected to regular use with capacity loads may fail due to overheating and loose connections.

Failure of an individual component, such as an electric shower or immersion heater element, may lead to an open-circuit fault. Photoelectric cells and time switches may fail in the 'closed position' and then do not operate as intended. Faulty RCDs may cause nuisance tripping. The correct operation of a suspected faulty RCD would need to be determined by the use of an approved RCD tester.

Modern RCD testers include a facility called a ramp test. The ramp test slowly increases the tripping current until the RCD trips. The display is in mA and will identify if an RCD is susceptible to nuisance tripping or is out of specification. It can also be used to indicate which circuits have high leakage currents and can be used when there is evidence of frequent trips on a particular RCD.

Under certain circumstances these tests can result in potentially dangerous voltages appearing on exposed and extraneous conductive parts within the installation. Therefore, suitable precautions must be taken to prevent contact by persons or livestock with any such part. Other users of the building should be made aware of the tests being carried out and warning notices should be posted as necessary. Cables that are terminated at an accessory contained in, or passing through, a metal box should be bushed with a rubber grommet to prevent abrasion of the cable.

Instrument and metering panels

Faults can occur in instrument and metering panels as a result of a faulty component, such as a burnt-out current transformer (CT) or voltage transformer (VT), or as a result of faulty test probes being applied to the instrument.

Protective devices

These may be subject to loose connections. If an incorrect device was selected for the circuit and does not offer the correct protection or selectivity, a fault may result.

Luminaires

Light fittings often fault because the lamp has expired. Fluorescent fittings (discharge lighting) grow dimmer with age and may even begin to flicker or to flash on and off. These are warning signals and the necessary repairs should be made as soon as there is any change in the lamp's normal performance. A dim tube usually requires replacement, and failure to replace it can strain other parts of the fixture. Likewise, repeated flickering or flashing will wear out the starter, causing the insulation at the starter to deteriorate.

Flexible cords

Many faults occur when flexible cords are terminated because they are:

- of too small cross-sectional area for the load
- not adequately anchored to reduce mechanical stresses
- not suitable for the ambient temperature at the point of termination.

Signal faults

Poorly installed cabling and poor connections can lead to electromagnetic interference (EMI). Electromagnetic interference can have serious effects on data and signalling cable used for information and technology (IT) systems or WiFi. If your WiFi router is located in a position adjacent to equipment that regularly switches, such as a fridge, the arcing caused by the switch creates EMI, which can cause WiFi to drop. Similarly, data or signal cables installed in close proximity to power cables are liable to signal faults brought about by the magnetic field induced around cables. See Chapter 3 of this book, in particular, page 199 for the section relating to Chapter 44 of **BS 7671** The IET Wiring Regulations.

Using instruments safely

When using test instruments to carry out fault diagnosis, follow these basic precautions to achieve safe working.

- Understanding the equipment: make sure you are familiar with the instrument to be used and its ranges; check its suitability for the characteristics of the installation it will be used on.
- Self-test: many organisations regularly test instruments on known values to ensure they remain accurate. These tests would be documented.
- Calibration: all electrical test instruments should be calibrated on a regular basis. The time between calibrations will depend on the amount of usage that the instrument receives, although this should not exceed 12 months under any circumstances. Instruments have to be calibrated under laboratory conditions, against standards that can be traced back to national standards; therefore, this usually means returning the instrument to a specialist laboratory. Once calibrated, the instrument will have a calibration label attached to it, stating the date the calibration took place and the date the next calibration is due. It will also be issued with a calibration certificate, detailing the tests that have been carried out, and a reference to the equipment used. Instruments that are subject to any electrical or mechanical misuse (e.g. if the instrument undergoes an electrical short circuit or is dropped) should be returned for recalibration before being used again.

HEALTH AND SAFETY

It should be remembered that components are less likely than poor installation practices to cause a fault on an installation. Therefore, adherence to EAWR and **BS 7671** is vital to ensuring that the electrical installation remains fault free.

Electrical test instruments are relatively delicate and expensive items of equipment. They should:

- be handled with care
- when not in use, be stored in clean, dry conditions at normal room temperature.

Furthermore:

- Check test leads: make sure that these and any associated probes or clips are in good order, are clean and have no cracked or broken insulation. Where appropriate, the requirements of the HSE Guidance Note GS38 should be observed for test leads.
- Select appropriate scales and settings: it is essential that the correct scale and settings are selected for an instrument. Manufacturers' instructions must be observed under all circumstances.

Interpreting test results

Table 7.2 (below) gives an overview of typical common faults, the instrument used to detect the fault and some typical readings, including what the readings may reveal. This table is for basic indications and does not replace a good level of experience!

▼ Table 7.2 Common faults found in electrical installations

Type of fault	Instrument used	Readings which indicate this	Other readings	What these readings may mean
Open circuit	Low-resistance ohmmeter	Open circuit (above range)	Readings that are not stable	Probable loose connection
Short circuit	Insulation resistance tester	0.00 MΩ	0.03 MΩ or above	Equipment still connected
Loss of supply	Approved voltage indicator	0 V	Readings indicating a lower than expected voltage	Possible lost neutral so the meter detects voltage but is unable to read it
Insulation failure	Insulation resistance tester	0.01 to 1 MΩ	Over 1 MΩ	Acceptable but may be deteriorating. Check previous results
High-resistance faults	Low-resistance ohmmeter	2 Ω or above for a single conductor	Lower values than expected through calculation will also cause high voltage loss and readings that do not settle may indicate loose connections	

FAULT RECTIFICATION

Electrical faults do not occur at convenient times, and fault diagnosis and repair are often undertaken in difficult circumstances. For the duty holder or person responsible for the electrical installation, it can be difficult to determine the most suitable arrangements for fault rectification, due to the potential for danger to people and equipment, time delay and lost production.

The consequences of a fault on an electrical installation can be considerable: lost production due to the unavailability of a machine, lost business where goods, products or services are not being made available to a customer and data loss

if, for example, the back-up UPS fails to function. Therefore, a suitable process needs to be established in order to keep inconvenience and costs to an acceptable level, without compromising the safety of users of the system and electricians undertaking the fault repair.

The process of fault rectification

Having identified the fault, the most suitable rectification process should be identified. This could be as simple as correcting a loose connection at an accessory terminal or undertaking a repair by replacing a faulty conductor.

Agreeing the process of fault rectification

Often the solution will be fairly straightforward but, in some circumstances, options must be discussed and agreed with the duty holder or responsible person. Some or all of the following issues may be open to consideration.

- What is the cost of replacement?
- What is the availability of suitably trained staff?
- Is it possible to replace a lesser number of components?
- What is the cost comparison of replacing or repairing a component?
- What is the potential disruption to the manufacturing process or computer availability?
- What is the availability of replacement parts, if required?
- Can other parts of the system be energised while the repair is carried out?
- What is availability of emergency or standby supplies?
- What is the anticipated 'down time' while a repair is carried out?
- Is there a requirement for a continuous supply?
- Will out-of-hours working be required?
- Are there any legal or personnel issues to be considered (warranties, contracts)?

Once the decision on how the fault rectification is to proceed has been made and agreed with the duty holder or responsible person, a work activity plan should be



▲ Figure 7.17 Is repairing something easier than replacing it?

prepared. This, once again, must be agreed with the duty holder. The plan should include a safe system of work and requirements for circuit outages.

Unless the fault diagnosis and rectification are being undertaken by an in-house electrician, site access must be granted by the duty holder or responsible person. This could involve a site induction, with site access passes being issued. There might also be a logging-in procedure (visitors' book) required for each visit.

The preceding arrangements are all concerned with a fault or supply failure on the client's system. However, the initial fault diagnosis may determine that the problem is connected with the system of the distribution network operator (DNO). If this is the case, the responsibility for the fault rectification rests with the network operator. Under these circumstances, it is good business practice to advise the client on how to deal with the DNO, requesting the provision of temporary standby supplies in the form of a back-up generator if required.

The work activity should be managed with appropriate technical support and resource allocations to ensure that an effective repair is completed within the agreed timescales.

Planning and agreeing procedures

Before fault diagnosis is carried out, the safe working arrangements must be discussed and agreed with the client and/or the duty holder (or responsible person for the installation) in a clear, concise and courteous manner. The testing and inspection procedure must be a planned activity as it will almost certainly affect people who work or live in the premises where the installation is being tested. This ensures that everyone who is concerned with the work understands what actions need to be taken, such as:

- which areas of the installation may be subject to disconnection
- anticipated disruption times
- who might be affected by the work
- health and safety requirements for the site
- which area will have restricted access
- whether temporary supplies will be required while the fault diagnosis is underway
- the agreement reached on who has authority for the diagnosis and repair.

It may be that a specific person has responsibility for the safe isolation of a particular section of an installation and that person should be identified and the isolation arrangements agreed. By entering into dialogue with the client before work commences, the potential for unforeseen events will be minimised and good customer relations will be fostered.

For example, in an office block where the electrical installation is complex and provides supplies to many different tenants located on a number of floors, the safe isolation of a sub-circuit for testing purposes may require a larger portion of the installation to be turned off initially. In order to achieve this with minimal disruption, an agreement must be reached between the competent person tasked to carry out the work and the person responsible for the installations affected.

This responsible person could be the office manager, the designated electrical engineer for the site or, in some cases, the landlord of the building.

Everyone involved in the work (e.g. client, electrician and those in the workplace) has a responsibility for their own health and safety and that of others who may be affected by the work. Communication between all parties will ensure compliance with the respective health and safety requirements.

Restoring the building fabric

There may be a requirement to disturb the fabric or structure of the building and, if this is the case, it is very important for all aspects of the rectification to be discussed with the client. Agreement must be obtained for the work to be undertaken, for the extent of the repair necessary (to brick, block, plaster, concrete, screed, plasterboard and decorations, for example) and for the contractual arrangements (who is paying for the repair). The fabric and structure of the building must always be left in a condition that does not compromise either fire safety or the building's structural performance.

Minor cosmetic repair works, such as patch plastering, disturbance to stud walls or decoration, are often within the capability of an experienced electrical technician, but you must always recognise your own limitations. Expert advice, such as from a specialist contractor, should be sought if any structural modifications are required.

Waste disposal

Another important part of the fault repair process is the safe disposal of waste in compliance with the relevant legislation, such as the Waste Electrical and Electronic Equipment (WEEE) Regulations, the Control of Asbestos at Work Regulations and other regulations linked to the Environmental Protection Act.

VALUES AND BEHAVIOURS

Proper waste disposal ensures good customer relations.

The WEEE Regulations apply to all electrical and electronic equipment placed on the market in the UK, in any of following ten product categories:

- large household appliances
- small household appliances
- IT and telecoms equipment
- consumer equipment
- lighting equipment
- electrical and electronic tools
- toys, leisure and sports equipment
- medical devices (except implants and infected products)
- monitoring and control equipment
- automatic dispensers.

INDUSTRY TIP

Access:

- the Waste Electrical and Electronic Equipment Regulations 2006 (WEEE Regulations) at: www.legislation.gov.uk/ukxi/2006/3289/contents/made
- the Control of Asbestos Regulations 2012 at: www.legislation.gov.uk/ukxi/2012/632/contents/made

The regulations require any 'producer' of such equipment, that is a manufacturer, rebrander or importer of electrical and electronic equipment, to finance the costs of collection and treatment of waste electrical and electronic equipment that arises over a calendar year, in proportion to the amount by weight placed on the market. Producers meet their obligations by registering with an approved producer compliance scheme. Through this scheme, producers fund reuse, recovery and recycling of electrical goods at an approved authorised treatment facility (AATF) or approved exporter (AE).

In 2009 there were several amendments made to the UK WEEE Regulations that mainly affect producer compliance schemes, approved authorised treatment facilities and approved exporters. The UK has also implemented an EU Directive (The Waste Framework Directive), which is the primary European legislation for the management of waste, through a series of regulations dealing with waste. The directive has been revised and these revisions have been implemented in England and Wales through the Waste (England and Wales) Regulations 2011 and ancillary legislation in Wales.

The on-site disposal of waste materials following electrical installation work will be dealt with in a number of ways.

- The packaging material from the electrical fittings and accessories (mainly cardboard) is normally stored and arrangements made for collection, transport and recycling.
- Small amounts of non-recyclable material can be disposed of in the electrical contractor's skip or in the client's skip, if agreement has been reached for this to take place.
- Off-cuts of cable, conduit, trunking, cable tray and general ferrous and non-ferrous materials are often collected for disposal at a metal recycling plant.
- Useable off-cuts of cable, conduit, trunking and cable tray should be returned to stock for future use.

Asbestos

The Control of Asbestos at Work Regulations 2012 affects anyone who owns, occupies, manages or otherwise has responsibilities for the maintenance and repair of buildings that may contain asbestos. Asbestos materials may be encountered by electricians during the course of their work. Asbestos materials in good condition are usually safe. However, if asbestos fibres become airborne they are very dangerous. This may happen when materials are damaged, due to demolition or remedial works on or in the vicinity of ceiling tiles, asbestos cement roofs, wall sheets, sprayed asbestos coating on steel structures, and lagging.

If asbestos is discovered during electrical installation or remedial work, work must be stopped immediately. Specialist contractors must be engaged to ascertain the condition of the asbestos and to determine any actions necessary for its removal, treatment or retention.

Fluorescent tubes

Fluorescent tubes generally contain 94% glass, 4% ferrous and non-ferrous metals and 2% phosphor powder, which itself contains mercury. Fluorescent tubes

HEALTH AND SAFETY

The disposal of asbestos should only be undertaken by specialist contractors.

are classified as hazardous waste in England and Wales and as special waste in Scotland. Preferably, they should be recycled or, if absolutely necessary, taken to specialist disposal sites. They must not be disposed of as general waste.

Leaving the installation safe

Once repairs have been completed, initial verification of the repairs may be required unless the replacement was a like-for-like accessory or item of equipment.

Any replacement of cable or modification of a circuit requires initial verification as detailed in Chapter 6.

Depending on the nature of repair, one of the following may be used to certificate the repair as safe:

- Electrical Installation Certificate (EIC)
- Minor Electrical Installation Works Certificate (MEIWC).

Electrical Installation Certificate

This would be used where the repairs were major or involved the rewire of a circuit or replacement of a distribution board. Only the circuit in question would be tested and the existing installation where no work was undertaken would not be included as part of the scope of the certificate.

Minor Electrical Installation Works Certificate

This would be used to certificate a repair or modification to an existing circuit which does not include the rewiring of the complete circuit.

Although a MEIWC is not required for a like-for-like replacement, such as the replacement of a damaged light switch, it is recommended that one is completed as this adds to the history of the installation and is good evidence when judging the history of an installation for a pattern of defects.

Test your knowledge

- 1 What is the **most** likely reason for the continuous operation of an RCBO protecting a lighting circuit within a building being refurbished?
 - a Overloading of the circuit.
 - b Damage to a concealed cable.
 - c Corrosion in a light switch.
 - d Loose earth connection in light.
- 2 What is the **most** likely cause when a circuit breaker operates, is re-set, then operates again after several minutes?
 - a Voltage drop.
 - b Overloading.
 - c Short circuit.
 - d Open circuit.
- 3 What is the **main** risk when working on isolated equipment having power factor correction capacitors?
 - a Shock through discharge energy.
 - b Shock from the supply cable.
 - c Burns from the outer casing.
 - d Fire from the capacitor electrolyte.
- 4 What is the instrument used to locate the fault on a circuit where the protective device continually trips with no loads connected?
 - a Low-resistance ohmmeter.
 - b Earth loop impedance tester.
 - c Insulation resistance tester.
 - d Phase sequence tester.
- 5 Which test result, from a previous schedule of test results, would be used for comparison when locating a potential loose connection in a radial circuit line conductor?
 - a $R_1 + R_2$
 - b Polarity
 - c RCD time
 - d r_1
- 6 What is the first test undertaken before any fault diagnosis work is carried out on a circuit where the circuit breaker keeps operating?
 - a Isolation test using an approved voltage indicator.
 - b Continuity using a low-resistance ohmmeter.
 - c Insulation resistance using an insulation tester.
 - d Earth fault loop using an earth fault loop impedance tester.
- 7 What classification code indicates 'danger present'?

a C1	c C3
b C2	d FI

- 8 What AC voltage is the minimum, above which GS38 applies to test leads?
- a 25 V
 - b 50 V
 - c 110 V
 - d 120 V
- 9 What factor affects the overall decision to replace or repair an item of equipment?
- a Equipment rating.
 - b Equipment orientation.
 - c Equipment downtime.
 - d Equipment manufacturer.
- 10 Which regulations control the disposal of electrical waste products?
- a BS 7671
 - b EWR
 - c WEEE
 - d PUWER
- 11 List three requirements of GS38 that are applicable to test leads.
- 12 Describe how a test of continuity can also prove polarity.
- 13 Explain why phase sequence is important on a three-phase installation.
- 14 Describe why some information and technology equipment may trip an RCD when there is no fault present.
- 15 Explain the term 'limitation' when used on an EICR.
- 16 What contributes to minimising inconvenience to a client when undertaking fault diagnosis work?
- a Posting warning signs.
 - b Securely isolating circuits.
 - c Clear communications.
 - d Following risk assessments.
- 17 What is the title given, under the Electricity at Work Regulations, to the person who has the electrical installation under their control?
- a Ordinary person.
 - b Responsible person.
 - c Safety supervisor.
 - d Duty holder.
- 18 Which document details the safety guidance for test instruments and leads used on electrical systems?
- a GS38
 - b GN1
 - c BS 7671
 - d Part P

- 19 What is the purpose of an EICR?
- a To document the condition of an existing installation.
 - b To certificate a new or rewired electrical installation.
 - c To document any alterations to an existing circuit.
 - d To confirm the safety of a newly installed circuit.
- 20 What report code would be given to a fault in a lighting circuit leading to a high earth fault loop impedance and increased disconnection times?
- a C1
 - b C2
 - c C3
 - d FI
- 21 Which of the following is already listed as outside of the scope of a periodic inspection on an EICR?
- a Sockets behind fridges.
 - b Wiring in roof spaces.
 - c Terminations in a switch.
 - d Circuits in a bathroom.
- 22 What instrument is most suitable for detecting an open circuit fault on an isolated circuit?
- a Voltage indicator.
 - b Insulation resistance tester.
 - c Low resistance ohmmeter.
 - d RCD tester.
- 23 Which of the following sets of readings would indicate a suitable single-phase supply polarity?
- a L-N: 230 V, L-E: 0 V, N-E: 230 V
 - b L-N: 0 V, L-E: 0 V, N-E: 230 V
 - c L-N: 230 V, L-E: 230 V, N-E: 0 V
 - d L-N: 0 V, L-E: 0 V, N-E: 0 V
- 24 Explain what is meant by the term 'extent' when undertaking periodic inspection.
- 25 Describe **two** risks associated with working around lead acid batteries.
- 26 Describe a risk associated with fault diagnosis on a system incorporating a UPS.
- 27 List **three** examples where asbestos may be encountered when undertaking fault diagnosis.

Practical task

A fault has occurred where an RCD trips at particular times of the day while equipment is used, but with no equipment in use, it does not trip. Describe a logical process for locating the fault.

Practice synoptic assessment

Part of your qualification is a synoptic assessment, to test your skills as a whole. These assessments are based on a particular electrical installation and an 'assignment brief' that generally outlines the assignment scenario.

The synoptic is normally broken down into four tasks as follows.

- 1 Design and plan the installation
- 2 Initial verification of the installation
- 3 Fault diagnosis and rectification
- 4 Self-evaluation.

Below is an example of what you can expect to see for a synoptic assignment, along with some tips about completing the non-practical tasks.

ASSIGNMENT BRIEF

You have been asked by your employer to design sections of the electrical installation for a new product repair and test facility within a new self-contained building on a large site. The floor plan for this new building is shown in the drawing.

When putting together a design for the installation, you have also been asked to consider a plan for the resource (labour and material) requirements. Your employer has provided you with the initial high-level requirements in the table below which you will need to present in a labour resource bar chart and a materials take-off sheet.

There are also a number of existing buildings on site, and as part of the contract you are required to carry out inspection and testing of the electrical installations installed within these buildings. In addition to this, the client has reported several faults which need to be diagnosed and rectified.

Once you have completed the inspection, verification and fault rectification, you will need to complete a self-evaluation reflecting on the work you have carried out. You will need to consider what went well and what you would do differently if you were to carry out a job like this again in the future.

LABOUR REQUIREMENTS

	Task	Duration	Operatives
1	Install ceiling lighting conduits	16 hours	2
2	Builders to erect internal stud walls	20 hours	N/A
3	Install conduit drops for switches	4 hours	2
4	Pull in lighting cables into trunking/conduit	8 hours	2
5	Builders screed floor (no other works allowed during period)	36 hours	N/A
6	Install dado trunking	8 hours	2
7	Suspended ceiling to be installed by others	18 hours	N/A
8	Pull power cables into trunking	6 hours	2
9	Fix distribution board (DB)	4 hours	1

	Task	Duration	Operatives
10	Terminate DB	4 hours	1
11	Install luminaires	8 hours	2
12	Terminate all luminaires	4 hours	1
13	Install and terminate wall sockets and switches	4 hours	1
14	Initial verification	8 hours	2

Note, the above tasks are not necessarily in logical order.

(Note, this drawing here is not to scale but the one in your actual synoptic assessment will be. It should be printed on A3 paper to allow you to use the scale to measure proposed cable routes and to estimate materials.)

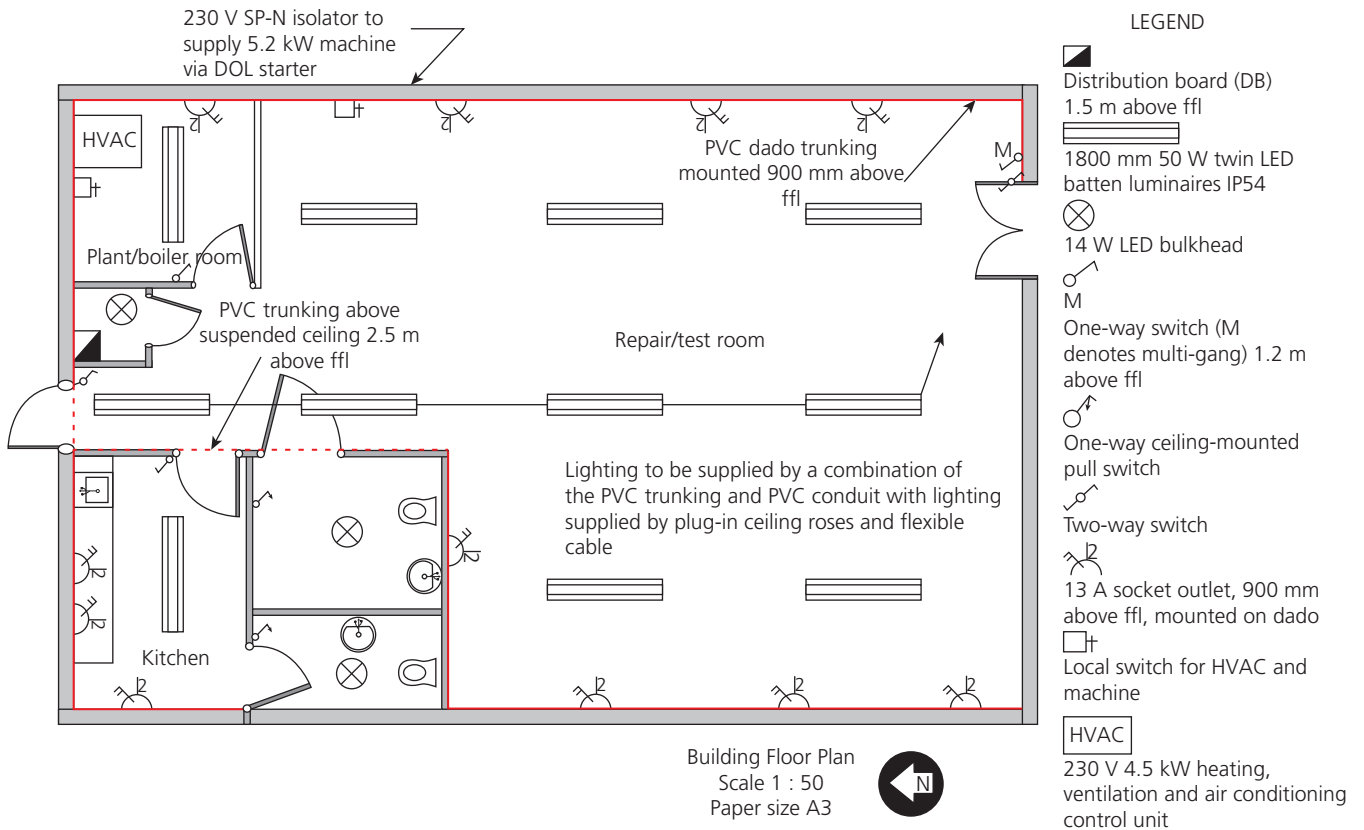

▼ Circuit design grid

Consumer unit located in workshop unit VOLTAGE DROP TO COMPLY WITH BS 7671	Nominal voltage (U) 230 V			Earthing arrangement TN-C-S External earth fault loop impedance (Z_e) 0.3 Ω		
Circuit	1	2	3	4	5	6
Description	Ring-final repairs & plant room	Radial-HVAC	Radial-sockets kitchen x3 twin	5.2 kW machine in repairs	Lighting repairs east/centre	Lighting repairs west/kitchen/toilets/HVAC
No. outlets	8 x 2-gang	1	3 x 2-gang	1	7	7

Consumer unit located in workshop unit VOLTAGE DROP TO COMPLY WITH BS 7671		Nominal voltage (U) 230 V		Earthing arrangement TN-C-S External earth fault loop impedance (Z_e) 0.3 Ω		
Type of wiring	70°C thermoplastic single-core non-sheathed	70°C thermoplastic single-core non-sheathed	70°C thermoplastic single-core non-sheathed	70°C thermoplastic single-core non-sheathed	70°C thermoplastic single-core non-sheathed	70°C thermoplastic single-core non-sheathed
Design current (I_b)	22 A (estimate)	19.6 A	9 A (estimate)	22.6 A	1.52 A	0.7 A
Type and nominal rating (I_n)	32 A B	20 A C	20 A B	25 A C	6 A C	6 A C
Length (metres)	58 m loop		10 m	9 m		20 m
Installation method		B	B	B		
Ambient temperature °C	25°C	25°C	25°C	30°C	30°C	30°C
Rating factor ambient air temp. C_a				1	1	1
Total circuits in group	2	2	2	1	2	2
Rating factor grouping C_g				1		
Minimum current capacity ($<I_t$)				25		
mV/A/m						
Actual voltage drop						
Minimum conductor csa mm ²			4	4	1.5	1.5

Tasks

Task 1 – Designing an electrical system

- 1a** Produce a labour resource bar chart and materials take-off sheet needed in the planning of the installation.
- 1b** Annotate the drawing to show routes for the PVC conduit runs to supply the ceiling mounted luminaires.
- 1c** Complete the design criteria within the design grid. Circuit lengths are to be estimated using the scaled drawing.
- 1d** Determine, for circuit 3 in the circuit grid,
 - the total earth fault loop impedance (assume the cpc to be one of the cores in the cable)
 - the suitability of this cpc for thermal constraints, using the formula contained in Regulation 543.1.3 in BS 7671.
- 1e** Annotate the drawing showing where self-contained standalone emergency luminaires should be positioned. Ensure you have indicated if each of the luminaires are maintained or non-maintained.

HOW TO APPROACH THE SYNOPTIC ASSESSMENT

Make sure you study the drawings and work schedule carefully and take in all information. Anything not mentioned may be assumed. It is always a good idea to list these assumptions as you go.

As the drawing in this book is not scaled, and the lengths of two of the circuits are required, we will take those as being:

- circuit 2 – 3 m
- circuit 5 – 22 m

In your synoptic assessment, always use the scale on the drawing and a rule and estimate your circuit lengths using given heights. You will probably not be exact, and you do not need to be. You are allowed up to 5 metres or so of tolerance either way where the wiring route is obvious. Where routes are not obvious, consider the shortest distance the wiring could take within the wiring systems. Also consider that for lighting circuits, wiring will go to switches but do not include switch line return wiring as voltage drop calculations already take into consideration the line and neutral of a circuit and the return from a switch is the same as a neutral.

The design part of a synoptic is about demonstrating understanding and this can be done by justifying everything you do. Where calculations are needed, show them in your work and why you have come to the conclusion that a result of a given calculation is right.

Try to remember that the work you produce will be marked and/or moderated by someone who has never met you, so you need to show what you know through your response to the assignment.

Appendix 1: Introduction to the electrotechnical qualifications

You are completing one of the following qualifications:

- Level 3 Diploma in Electrical Installation (2365-03)
- Level 3 Technical Certificate in Electrical Installation (8202-30)
- T Level Technical Qualification in Building Services Engineering for Construction (8710)
- Level 3 Electrotechnical Qualification (installation or maintenance) (5357-03).

These qualifications aim to equip you with the practical skills and technical knowledge necessary to help you gain employment within the industry, or progress your training within the current apprenticeship route.

Alternatively, you may be completing the Level 3 Technical Certificate (8202-30) as a means of progressing to further education at Level 4 and above.

Whatever route you wish to take, these qualifications fully integrate with each other, allowing seamless progression.

HOW TO BECOME AN ELECTRICIAN

To become a fully recognised electrician, you must complete the following:

- 5357-03 knowledge units
- 5357-03 on-site performance units
- Achievement Measurement Test 2 (AM2) synoptic end test.

In addition, on completion of the above, you may also gain EngTech recognition from the Engineering Council through a fast-track process, as the on-site performances measure the behaviours the Engineering Council requires for this recognition. That means you can use the EngTech initials after your name, showing professional recognition.

If you are not currently enrolled on the Electrotechnical Qualification (5357-03), do not worry. You can transfer your skills gained through the Diploma or Technical Certificate towards the 5357 knowledge units, meaning you will not need to complete all of the assessments.

The easiest way to explain your progression route is to show each qualification side by side.

INDUSTRY TIP

For more information on EngTech, please visit the IET's website.

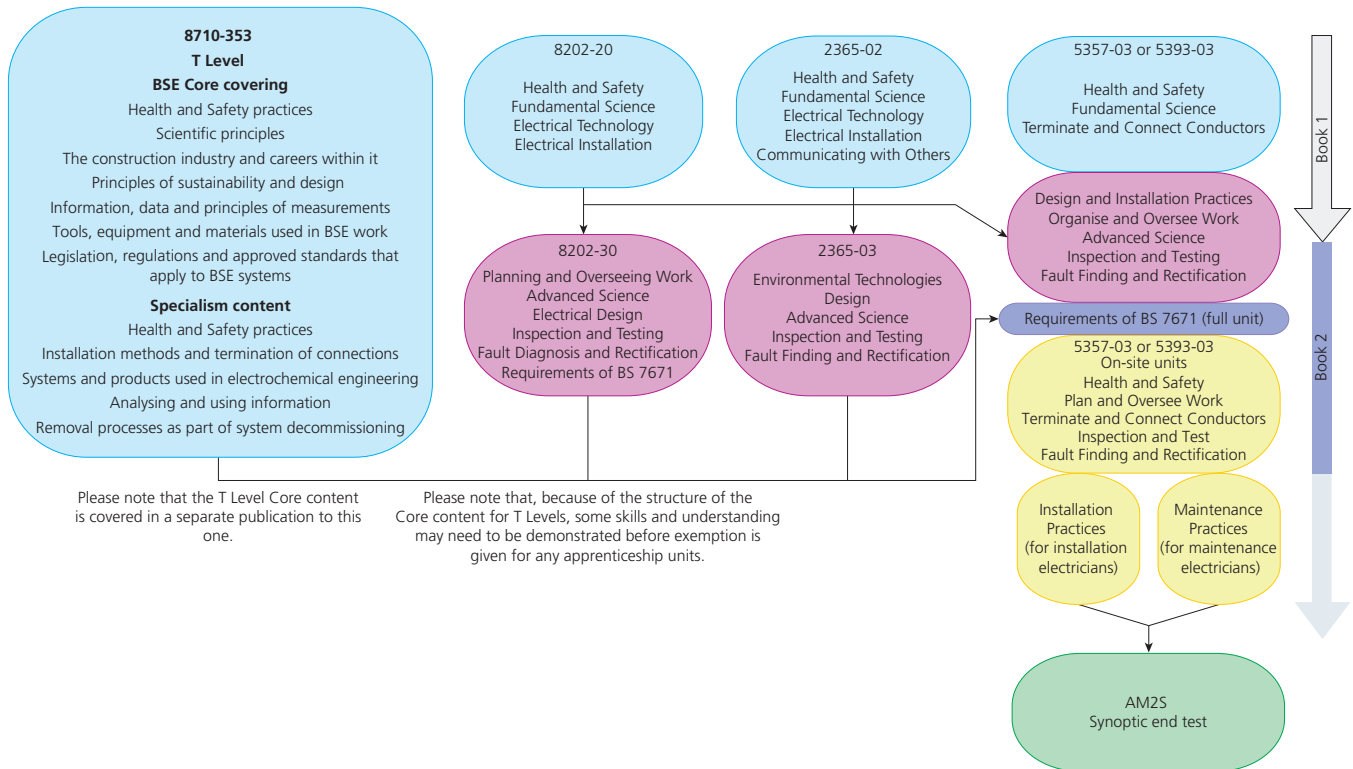

▲ Qualification progression routes

The 5393 Domestic Electrician Apprenticeship was introduced in September 2022 as an alternative apprenticeship to the 5357 route, specifically for those who work solely in domestic dwellings. The unit structure is very much the same as 5357.

Why are there different routes?

The route you take into a career as an electrician will depend on a number of factors, such as your age, employment status and where you live within the UK.

- Learners who are 16–19 and not employed full time within the electrical industry would enrol on 8202-20 or 8710-353.
- Adult learners wishing to become electricians would enrol on 2365-02.
- Apprentices of any age working within the electrical industry would enrol on 5357-03 to become full electricians, or 5393 to become domestic electricians.

How to achieve your qualification

The requirements for successfully obtaining your qualification depend on which programme you are enrolled on.

8710 T Levels

T Levels are nationally recognised qualifications that are equivalent to 3 A Levels but focus on specific careers in industry. T Levels are two-year full-time courses of study.

As well as classroom- and workshop-based learning, 8710-353 (Electrical Engineering) or 8710-352 (Electrical and Electronic Equipment) provide, within the course, nine weeks of work experience with an employer.

The courses share a core unit that looks at the common elements across building services and this serves as a great insight into other occupational specialisms, including the science behind them. So, as well as learning about the electrical industry, students will also learn much about the other building services such as air-conditioning systems, heating, etc.

In addition, the course covers the specific specialism content which is covered in this book.

At the time of writing, it is anticipated that the T Levels will integrate into the 5357 apprenticeship in the same way as 8202 and 2365.

The diagram above shows the progression route with T Levels.

8202-20/30

Level 2 is assessed using one on-screen multiple-choice examination and one practical synoptic assignment.

For the synoptic assignment, a typical brief might be to install a cable and wiring system. You will need to draw on skills and understanding developed across the qualification content in order to consider the specific requirements of the particular wiring system and the related electrical principles, and carry out the brief. This includes the ability to plan tasks, such as marking out and cutting cables, and apply the appropriate practical and hand skills to carry them out using appropriate tools and equipment.

You will also demonstrate that you are following health and safety regulations at all times by drawing upon your knowledge of legislation and regulations.

The exam draws from learning across the entire content of the qualification, using multiple-choice questions to:

- confirm breadth of knowledge and understanding
- test applied knowledge and understanding – giving candidates the opportunity to demonstrate higher-level integrated understanding through application, analysis and evaluation.

At Level 3, you are expected to complete a written examination, marked by external examiners, which covers the knowledge requirements across all of all units.

You will also need to complete a synoptic assignment that covers the following subject areas:

- electrical design
- inspection, testing and commissioning
- fault diagnosis and rectification.

Your work could be subject to moderation by external moderators.

2365, 5357-03 and 5393-03

The Level 2 2365 and the corresponding units of 5357-03 are assessed using a range of assessments, including practical assessments, written examinations and online multiple-choice examinations. Each examination, whether it be written or multiple-choice, will have a test specification. These test specifications show the following information:

- assessment method, e.g. multiple-choice/written
- examination duration
- permitted materials, e.g. closed/open book
- number of questions
- approximate grade boundaries

The grade boundaries may be subject to slight changes to ensure fairness, should any variations in the difficulty of the test be identified.

In addition, within 2365-03 and the advanced stages of 5357, you will be expected to demonstrate your knowledge of the following, using a range of projects and practical assessments:

- designing electrical installations
- inspection, testing and commissioning
- fault diagnosis and rectification.

INDUSTRY TIP

The way in which knowledge is assessed by each test is laid out in the Test Specifications. These can be found on the qualification pages at www.cityandguilds.com, by searching the qualification number at the top of the screen.

Only candidates who are enrolled on 5357-03 are assessed on their knowledge and understanding of the requirements of **BS 7671**, in the form of a multiple-choice assessment. Those who are enrolled on 2365 or 8202 would need to complete this assessment, or City & Guilds 2382, in order to progress onto the industry end point assessment known as Achievement and Measurement test 2, or simply AM2.

There are several AM2 end point assessments depending on your pathway. For example, AM2D is for the domestic electrician apprenticeship and AM2S for full apprenticeship.

The Evolve platform

All City & Guilds multiple-choice online tests are taken using the Evolve platform. The following points explain how you can navigate the Evolve tests.

- 1 Signing in.



- The keycode is not case sensitive.
- Change screen colour scheme. This can also be done later, or at any time during the exam. See Section 5.2.2 for more details.

- 2 Once you have signed in using your keycode, you can change preferences. Some people prefer to read text using different colours or different backgrounds. For example, some people with dyslexia find reading black text on a yellow background much easier. If you do not set preferences, the default will be black text on a white background. You can change your preferences at any point during the examination.



- 3 You will then be shown a screen with your details. Ensure they are correct as you wouldn't want to pass an exam for someone else!

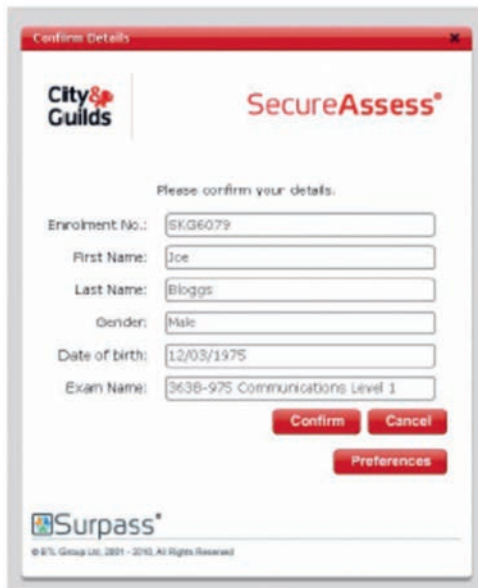

- 4 The welcome screen will give you options to either take a practice familiarisation session, or to carry on and start your examination. The clock does not start until you start the actual exam so if you are not familiar with the features of an Evolve test, use the practice session.



- 5 When you are taking the examination, the screen has several features.

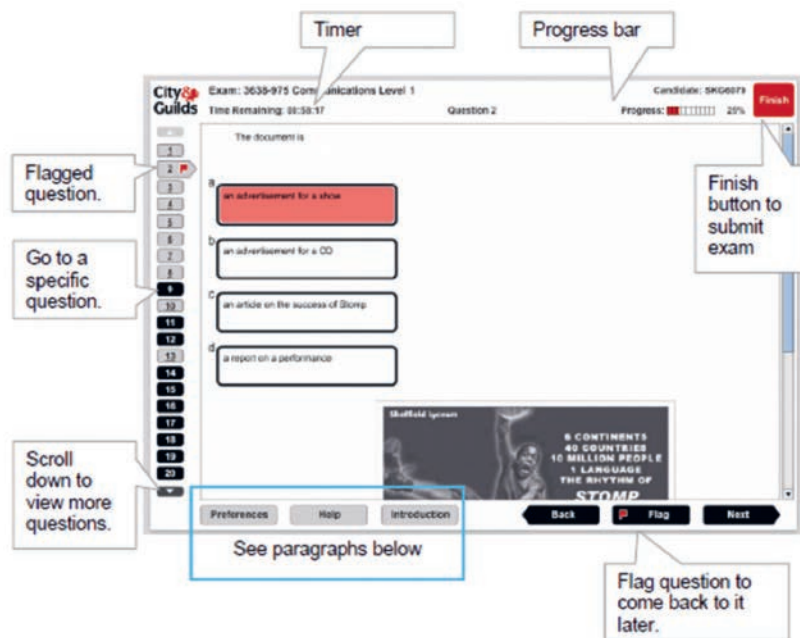

- *Timer* – shows the time remaining for the examination.
- *Progress* – gives you an indication of how much of the examination you have completed.
- *Finish* – only click this button when you are sure you have completed the examination.
- *Question numbers* – the numbers at the side show the individual question numbers. These indicate the questions that have been answered and the questions that have not been answered. They also indicate any questions that have been flagged (see below). You can navigate through the questions

by clicking on each number or by using the 'back' and 'next' buttons at the bottom of the screen.

- Flag – if there are any questions you had doubts with, click the 'flag' button and a flag will appear by the question number. This means you can easily navigate back to that question should you have time.
- *Preferences* – throughout the examination you can change the screen preferences.
- Help – this offers help with the features of the system (not with the examination questions, unfortunately!)
- *Introduction* – takes you back to the welcome screen.

INDUSTRY TIP

This section will also provide useful information for those enrolled on 2365 Unit 308, Career awareness in building services engineering.

KEY TERMS

Competent or **skilled**: the person has sufficient and relevant **knowledge** and **experience** in working on electrotechnical systems

KEY TERMS

Achievement Measurement 2 (AM2) Practical Performance Assessment: an industry-devised skills assessment of competence for the apprenticeship framework (City & Guilds 2357) and Mature Candidate Assessment. It should not be used for students undertaking the new apprenticeship standard (City & Guilds 5357) and will not be accepted as the end-point assessment for the standard.

AM2S: the end-point assessment for the new apprenticeship standard (City & Guilds 5357). It should not be used for anyone on the older apprenticeship framework or undertaking the Mature Candidate Assessment. The AM2 and AM2S assessments are managed by NET. More information can be found at www.netservices.org.uk

Appendix 2: Next steps

What defines an electrician? Working on electrical installations as an 'electrician' is not a regulated industry role. What that means is that there is no single stipulated qualification to become an electrician.

In terms of the law, the Electricity at Work Regulations (1989) state that persons working on electrical systems should be **competent**. **BS 7671** refers to persons being **skilled** or instructed (electrically).

THE ELECTROTECHNICAL CARD SCHEME (ECS) GOLD CARD

The benchmark many use to qualify the term 'electrician' is the Electrotechnical Certification Scheme (ECS) Installation Electrician Gold Card.



▲ The ECS Gold Card

The routes to obtaining an ECS Gold Card are varied and the knowledge requirements used to demonstrate competence depend on the qualifications you hold. There are a range of ECS card occupations; each has their own qualification requirements, listed on the ECS card website.

Two common factors are that all those applying for an ECS Gold Card must be able to demonstrate their experience by:

- completing on-site assessments to prove that they have suitable on-site experience
- successfully completing a competency or end-point assessment such as the **AM2**, **AM2S** or AM2D.

To apply for an ECS Installation Electrician Gold Card, you must hold a formal JIB-recognised electrotechnical apprenticeship, or a JIB-approved equivalent qualification that meets the same industry benchmark. The AM2 or AM2S must also be held.

ELECTROTECHNICAL QUALIFICATIONS

For more information about qualification routes, see www.hoddereducation.co.uk/subjects/general/products/16-19/the-city-guilds-textbook-electrical-installatio

HOW TO PLAN FOR CAREERS IN THE ELECTROTECHNICAL INDUSTRY

The only possible way to be eligible to apply for an ECS Gold Card is to be employed in the electrical industry. Opportunities for employment can be rare; to ensure you are in the best possible position to be considered for employment, or even to get an interview, it is a good idea to plan for an opportunity or make yourself known.

Resources for career planning

There are many publications that relate to career development, time management and personal improvement. If you invest time and commitment in studying these, you will reap the rewards in terms of ensuring you are prepared and ready to enter the job market.

The internet is an accessible source of information to support career planning.

The most useful sites for career planning are generally those provided by UK government departments or agencies sponsored to promote career awareness.

The National Careers Service provides general advice and career planning information. Once you have decided on your career path, the National Careers Service website can provide useful information in a general context, including information on government support and guidance. Depending on circumstances, individuals may be able to seek government funding support for certain retraining.

Specific requirements and qualifications need to be researched from relevant trade organisations, competent person registration schemes, etc. There are many UK Accreditation Service (UKAS) accredited awarding bodies that provide support and guidance to trainees and to those already qualified and wishing to update themselves and maintain their own continuing professional development (CPD). If you are already qualified in a specific trade or profession, your professional institution will have a recognised development programme, criteria for meeting their requirements, a mapping process and access to mentors so you can complete the process.

Organisations such as the Joint Industries Board (JIB) also provide support to member companies and their employees. Much of the JIB's work relates to practical issues such as pay and conditions, and relies on the employer accepting the JIB's terms. However, it gives employees of member organisations access to mentors, etc., to ensure that they adopt an appropriate approach and undertake

INDUSTRY TIP

Only use websites from verified industry sources. Always assess the quality of the information provided in light of the original purpose of the website or blog; for example, many websites only relate to employment in one country, or to a specific industry sector. Before relying on such information, make sure it is relevant to your needs.

INDUSTRY TIP

The National Careers Service can be accessed at <http://nationalcareersservice.direct.gov.uk> (It is funded in association with the European Social Fund and is provided on behalf of the Department for Business Innovation and Skills.)

appropriate development in order to achieve ECS gold card status, once the training period has been completed.

If you wish to develop other skills, such as estimating and design, the next step is to register with a professional institution such as the Institution of Engineering and Technology (IET). This provides a route to developing a career path in engineering or management. The IET provides information and guidance on the qualifications and experience you need to progress to the desired level. It also provides **mentors** to talk through application and development issues to make the process of gaining qualification and membership easier.

KEY TERM

Mentor: an advisor, counsellor or trainer who gives guidance and acts as a role model.

ACTIVITY

Visit the IET website at www.theiet.org

Investigate what technical assistance the institution offers to trainees or newly qualified operatives.

ACTIVITY

Obtain copies of electrical trade magazines that contain job advertisements from employers and recruitment agencies. Assess which of the roles that are being advertised most closely match your skills and knowledge and the qualifications you hold.

INDUSTRY TIP

Some people find networking difficult. However, simply keeping in touch with colleagues can be an effective way of finding out what is happening within the job market.

KEY TERM

SWOT analysis: The assessment of Strengths, Weaknesses, Opportunities and Threats.

Recruitment

Recruitment agencies operate in all employment sectors. These organisations will offer your curriculum vitae (CV) and services around their contacts. If an employer agrees to employ you, the agency will charge the employer a finder's fee.

Another common method of recruitment is to place advertisements in local or national newspapers or in professional journals. In this way, an employer can target a specific audience for an advertisement.

Other routes to employment include attending recruitment fairs and individual company recruitment events.

Networking

Networking events are useful for finding out what opportunities are available in the market place and where they are being offered. It is also a useful method for targeting specific positions of work. It might be the slowest method for finding employment, but it has the potential to reap the best rewards.

Elements of career planning

Analysis

When planning your career, the first thing to look at is what you can already do. Ask yourself: What am I already good at or what do I have an aptitude for? It may be that you already have a number of skills and qualifications that are transferrable to a new career. A useful self-analysis tool is **SWOT analysis**.

SWOT analysis is a simple tool for examining strengths, weaknesses, opportunities and threats. It is credited to Albert Humphrey, who led a convention at the Stanford Research Institute in the 1960s. Although SWOT analysis is normally associated with examining the strategic position and aims of corporate organisations, it can also be applied to an individual's goals or objectives.

Strengths are the qualities that allow a business or individual to move towards their goal, assuming the status quo means that no changes are needed and they can continue as they are.

Weaknesses are the characteristics that hold back or impede a business or individual. If they do not address these weaknesses, an individual might lose a

particular job or a business might lose an opportunity to a competitor who has developed a strength in that area.

Opportunities are the openings or changes in the external environment that can bring about new challenges or horizons. An example could be a newly qualified 20-year-old electrician who has shown an interest in inspection and testing. This type of work is normally given to more experienced workers but, due to an unusual level of sickness in the company, this electrician is asked to carry out inspection and testing on a number of industrial projects. The company say that, subject to the work being completed to a satisfactory standard, any future work of this type will be given to this individual. When a permanent testing job becomes available, the individual will have the required experience.

In a business context, threats usually come from competition or changes in the market. They can come from anywhere and are usually more devastating when they come from an unanticipated source. Therefore, when 'horizon scanning' for opportunities, it is necessary to check if there are also any threats, such as a competitor moving into a new area of business that overlaps yours. Every threat should be examined. Responses to threats bring about change, which will usually create opportunity.

SWOT analysis involves a mixture of internal and external factors:

- **Internal strengths:** What are you good at?
For example, I can rewire a house more quickly than anyone else, so I should focus on the domestic market where I excel over others.
- **Internal weaknesses:** What do you believe you could do better?
This is normally something you don't like to do. For example, I don't fill in my inspection forms very neatly as my handwriting is poor.
- **Opportunities in the external environment:** What can you do that is different or how can you adapt to a changing environment to address new opportunities to be successful?
For example, the surge in people wishing to train has created a demand for additional tutors, which gives me the opportunity to teach at evening classes.
- **Threats in the external environment.**
The increase in general unemployment levels and the financial climate has created a shortage of work across all industries. However, with my qualifications I can look to work as an assessor for a Competent Person Scheme operator, which is less prone to the financial challenges faced by companies in the construction industry.

These factors can be analysed for a particular venture or career objective and represented in a matrix or diagram format, to allow easy interpretation of the results.

	Positive factors	Negative factors
Internal	Strengths <ul style="list-style-type: none"> • example • example • example • example 	Weaknesses <ul style="list-style-type: none"> • example • example • example • example
External	Opportunities <ul style="list-style-type: none"> • example • example • example • example 	Threats <ul style="list-style-type: none"> • example • example • example • example

▲ Example of a SWOT analysis diagram

INDUSTRY TIP

Setting your targets too low could lead you to become dissatisfied in your role. Setting your targets too high, too soon, could cause you to lose confidence and motivation to progress.

Knowing yourself

Having taken stock and reviewed your existing skills and qualifications, you need to consider what you would like to do in the future. Challenge and push yourself while being honest about your skills and strengths to set realistic targets and milestones that you can achieve.

Once you have decided what you want to do next, you should determine what you need to do and learn in order to achieve your goal. This will involve finding out what is really required to fulfil the job or career objective, including what training you will need.

Goal setting

Setting goals is an important step towards a strategy for change that will lead you in the direction you want to go. People often refer to setting goals and objectives without any thought to the difference between the two terms. However, it is important to understand the difference, to avoid using the wrong terminology.

- **Goal:** a strategic requirement or outcome that an individual or organisation is trying to reach. It is likely to be quite general and long-range; it can look quite idealistic and doesn't include all the practical details of exactly what is required and when it is required by. An example of a goal could be to have a complete career change within the next five years. This may be not fully detailed but that goal is the starting point in the planning process.
- **Objectives:** short-term tactical approaches that help to achieve a goal. Asking 'who, why, what, where and when?' questions will assist you in deciding on appropriate objectives. They should be clearly defined and an effective objective needs to be **SMART**.

A SMART objective is:

- Specific (clearly defined so you know exactly what needs to be achieved)
- Measurable (there are concrete criteria for measuring progress and successful completion)
- Achievable (you know it is possible to achieve)
- Realistic (you have the time and resources to achieve it)
- Timely (there is a deadline for completion).

In setting each objective, check that it meets the SMART criteria and that the intended outcome will meet, or help to meet, the overall goal. Progress with objectives should be reviewed regularly, at timely intervals that allow for specific stages to be realistically achieved. A review may show that the objective is working well towards the goal, needs changing slightly to achieve the same goal or needs changing altogether. It may also be that the overall goal needs to change, in which case new objectives will also be needed. If objectives need changing, you simply start the process again.

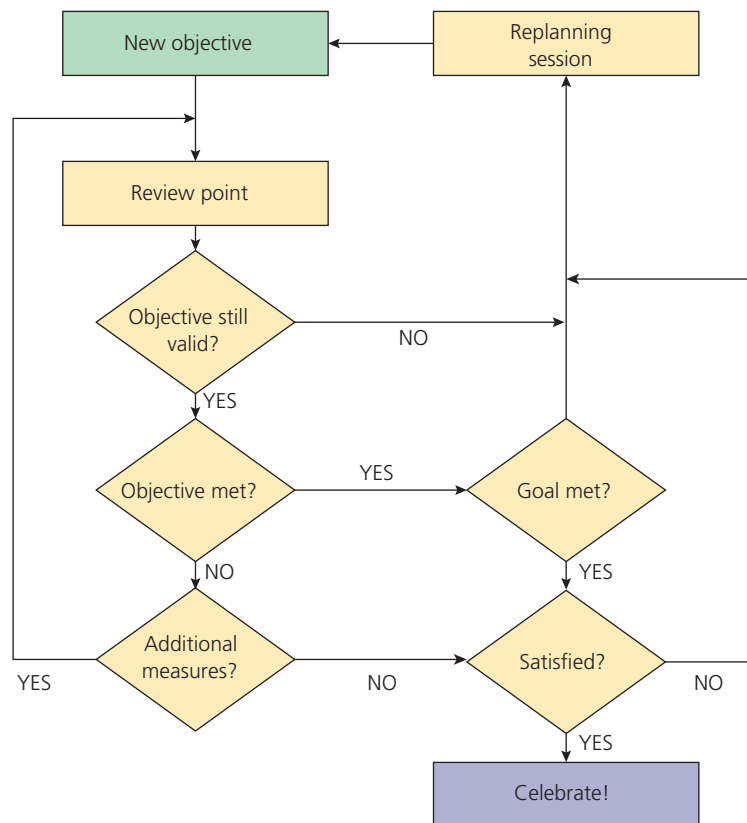

▲ Example of an objective review

Personal goal setting

Personal goal setting is an excellent way to think about your ideal future and motivate yourself to turn your vision of this future into reality. Setting goals helps you choose where you want to go in life. It is generally acknowledged that goal setting motivates individuals to 'better themselves' or to achieve more.

Goals give an individual something to aim for. However, as with setting objectives, when setting a goal it is important that it is achievable. It is easy to be discouraged, go off target or even give up if your goal is not achievable. Impossible goals are merely pipe dreams, so aim high but keep it real.

Goals give you the opportunity to study the 'bigger picture', to take stock of your wishes and aspirations and to set down what you want to do and where you would like to go.

Initially, a brainstorming or concept-mapping session with a relative or mentor will allow you to record lots of different ideas. Goals can be selected in different categories or areas of life, such as:

- career
- education
- relationships
- finances.

In an ideal world, the goals would be complementary to each other so that one supports or assists the other.

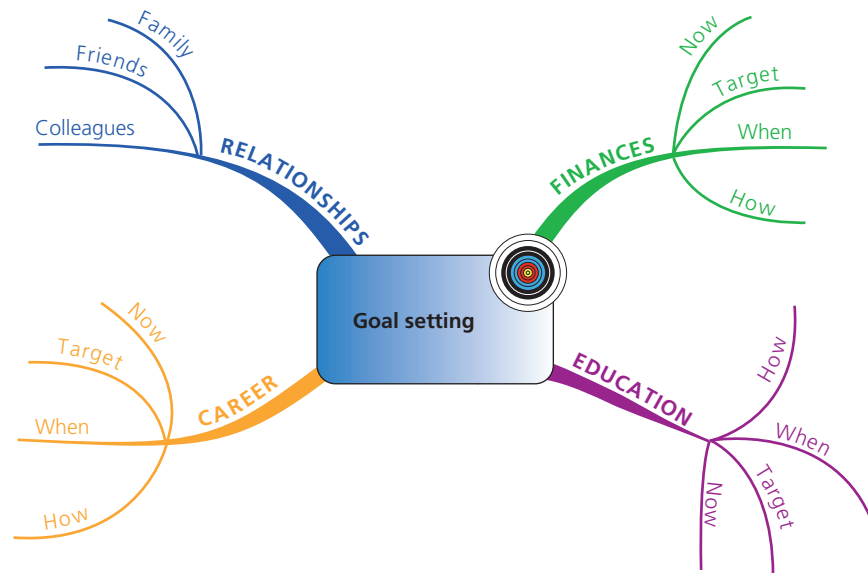

▲ Use a visual image like this to map out your thoughts

The next stage after the brainstorming or concept-mapping session is to trim down or prioritise your goals, so that initially you do not have too many, as failure to achieve can often be demotivating. It is important that they are goals that you really want to achieve, not ones that others want you to achieve.

INDUSTRY TIP

Write the goals down: this makes them tangible and real.

Setting these lifetime goals gives you perspective, allowing you to shape your decision-making processes for the future.

Once you have set lifetime or big-picture goals, you need to break them down into smaller goals, as milestones on the way to achieving the overall goal. Milestone goals need to take a SMART approach in the same way as objectives (see page 460). If you never meet any of the smaller goals used as midway markers, they will put you off instead of providing motivation.

In summary, you should take these steps:

- 1 Look at the bigger picture (assisted by brainstorming, mind mapping, etc.).
- 2 Look at where you want to be (starting with only a few goals in small bite-sized chunks).
- 3 Make sure the goals are your goals (not what someone else wants for you).
- 4 Set milestone goals (to check you are on course and it is still what you want to do).
- 5 Review and set short-term SMART objectives to ensure you meet your milestone goals.

Documents to support career development

There are a range of documents you can obtain or create to help you on the career path throughout your working life, from initially getting a job in the industry, to progressing further within the organisation once qualified, or perhaps setting up your own company.

Career action plan

A career action plan is a useful document for planning career development. It allows you to plan your career and development in your existing job, or to plan a different career path in the future. It helps you to look at the skills and qualifications you need to reach your goal, and then to monitor your progress. A typical career action plan can be developed by asking the following questions:

- Where am I now and what electrical qualifications and skills do I possess?
- What do I like about where I am and what skills do I most like to use (academic or practical perhaps)?
- What do I want to change, for example do I need to go further with my skills and perhaps take an electrical short course such as Portable Appliance Testing (City & Guilds 2377) or inspection and testing (City & Guilds 2391)?
- How can I change what I don't like, such as aspects of the electrician's role that I do not want to work on?
- What will I need to create that change, and will I need further training in a specific or specialist area?
- How do I get there?

After careful consideration, you can decide on a goal. An example might be to gain more experience in inspection and testing. You should set a target date for achieving your goal. In this example, it might be in 12 months' time. In order to reach your goal, you will need to make a plan and put it into action.

As you progress towards your goal, your action plan will make it clear when you are on track or going off track. It may even show that you need to change direction altogether, in which case you can re-plan and create a revised action plan.

Plan–Do–Check–Act

Many organisations use the Plan–Do–Check–Act (PDCA) process in their professional development or career development programmes. Also known as the Deming Cycle, the PDCA process is made up of these factors:

- **Plan** – establish objectives to deliver the required goals.
- **Do** – carry out the plan.
- **Check** – study the results to spot any differences between the actions planned and done.
- **Act/adjust** – take corrective action to put the plan back on course.

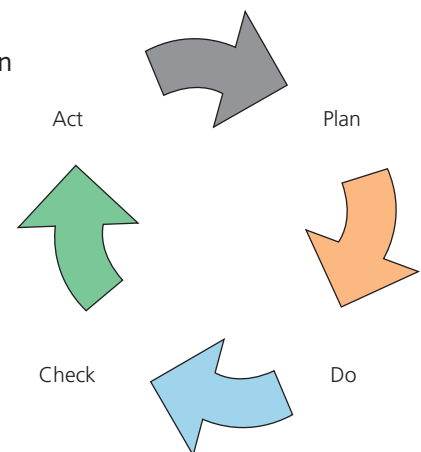

▲ Plan–Do–Check–Act (PDCA)

Applied logically, this approach can be used for any type of development process, personal or professional. Here is a career development example:

- **Plan:** to become a fully qualified designer, holding a City and Guilds Level 4 2396 certificate in design of electrical installations, and gain employment or work experience in a contractor's design office within the next 12 months.
- **Do:** within 8 months you obtain the qualification.
- **Check:** after 10 months, no opportunities have arisen to work in a design office, but there have been many for working as an electrician with medium-sized enterprises.
- **Act/adjust:** as the opportunity to go straight into design has not arisen, work closely with the organisation as an electrician but take an interest in the design aspects – opportunities may come along.

Portfolio

A portfolio is a collection of well-presented documents, such as your site-based portfolio, that demonstrates the type and nature of work an individual (usually a student or trainee) has carried out. It can be presented as a collection of evidence to show what the individual can do, either to the assessor of a course or to a potential employer in place of a detailed curriculum vitae (CV).

INDUSTRY TIP

Employers usually scan CVs rather than reading them thoroughly. Therefore, it is essential to limit your CV to two pages if possible, making sure that the important information is clearly visible.

Curriculum vitae (CV)

A CV is an important resumé of your work and professional experience to date. Ideally CVs should be short and easily readable to keep the reader's interest. They should be supported by a covering letter when you apply for a job.

A good CV sets out all the details that a potential employer needs to decide whether you have the skills and experience required for the position you are applying for. The details must be informative, clearly presented and to the point. The aim is to get the employer to invite you for an interview.

Make sure the information provided first is most specific to the role, for example listing your electrical qualifications before your GCSEs. Do the same with your experiences and achievements: there is no point listing a 50 m swimming badge at the top of your achievements when applying for a job as an electrician.

Ensure you have some people who are able to provide a reference for you, should this be required. You must have their agreement.

There are many different ways of presenting a CV. However, information must be presented in a logical order.

Initial information

This should include your personal details, address and contact information.

Personal statement

The next element of the CV should be a personal statement outlining your key strengths and achievements. Include those you think will be important and relevant to the potential employer. If possible, tailor this statement to suit the needs of each employer you contact, so that they can quickly check your skills and attributes against their requirements. Limit your personal statement to 200 words.

Experience and qualifications

It is often useful to indicate your work experience next. It is essential to identify all your relevant experience, without including any information that an employer does not need.

It is usual to list work experience in reverse chronological order. This means presenting your current position first, with the date you were appointed, describing your role, responsibilities and any achievements or professional developments made.

Repeat this for each previous employer. Consider including less detail, as you go back in time, to help keep your CV as brief as possible. There is little need for a chartered engineer of many years' experience, for example, to go into much detail about their apprenticeship. It would be better to choose a few words to cover the overall experience and save the space for more important details elsewhere on the CV.

If you are still studying, or if you have lots of experience in a large number of positions, you might choose to give your qualifications first so that a prospective employer can see them more quickly. Present your education in reverse chronological order, indicating all the educational establishments you have attended or are still attending.

Other skills, hobbies and interests

Next include other skills that are relevant but not job-specific. For example, you may have particular computer skills, fluency in a foreign language or be a qualified first-aider. A short section relating to your hobbies and interests may also be included if you feel they are particularly relevant to the position you are applying for.

Referees

If requested, you should provide the contact details for your referees (see 'References' below). However, if your CV is speculative and not in response to a specific request, you simply say that referees' details are available on request so that you can keep control over other people's contact information.

INDUSTRY TIP

Make sure you research the company you are applying to. You should visit the company website and read any information about the company background and services. You should demonstrate in your cover letter that you are knowledgeable about the company's background and **ethos** to demonstrate how you are suited to the role and how you would fit well into the company structure.

KEY TERM

Ethos: the beliefs and approach of a group or institution.

INDUSTRY TIP

If you have named someone as a referee, it is good manners (but often overlooked) to let them know so that they are prepared for the contact, which is sometimes initially by telephone. This avoids potential embarrassment and also ensures you have the referee's cooperation, which is useful in terms of receiving a positive reference.

CURRICULUM VITAE: John Jones

PERSONAL DETAILS

Name John Jones
 Date of birth 11 November 2002
 Address 1 Market Street
 Any Town
 Any City
 AB12 3CD
 Mobile 0799 321654
 E-mail john.jones@interweb.co.uk

Personal statement

I am currently working as a personal care and support carer. I always worked hard at school and was head boy in my last year. I believe this shows I have maturity and a sense of responsibility. My school results show I am able to pass examinations. I believe I would be an excellent trainee electrician.

SCHOOL EDUCATION

2012–2019 Any Town High School
 School Road
 Any Town
 AD12 3CE
 Telephone: 01789 567123

Qualifications obtained

Subject	Level	Grade achieved	Date achieved
Maths	GCSE	8	July 2019
English Language	GCSE	8	July 2019
English Literature	GCSE	7	July 2019
Science	GCSE	7	July 2019
Additional Science	GCSE	5	July 2019
Spanish	GCSE	6	July 2019
Geography	GCSE	4	July 2019
Media	GCSE	8	July 2019
Drama	GCSE	6	July 2019

▲ Sample CV

Covering letter

This letter should be professional and to the point, although it should say more than just 'please find the enclosed CV...'. It provides a chance for you to show that you understand the employer's organisation and how your skills and experience can meet their requirements. It is a chance to stand out from the other applicants so that the reader will consider your application carefully.

References

References are important to verify what sort of person you are and whether you are reliable, honest, trustworthy and, most importantly, employable.

Ideally, your referees should know you personally. It is better to have a reference from your supervisor, who knows and works with you closely, rather than a standard employers' reference from the managing director, who may only exchange pleasantries with you.

Glossary

Achievement Measurement 2 (AM2) Practical Performance Assessment

An industry-devised skills assessment of competence for the old apprenticeship framework (City & Guilds 2357) and Mature Candidate Assessment.

Additional protection by an RCD is in addition to the basic protection. If someone puts a nail or screw through a cable, they have compromised the basic protection (the insulation).

AM2S The end-point assessment for the new apprenticeship standard (City & Guilds 5357).

Arc fault detection devices (AFDD)

Devices that detect variations in the current sine wave, which are common when loose terminals cause arcing. If these devices detect the signature of an arc, they disconnect the circuit in question.

Average conditions Not too much heat and not too humid. Humidity causes sweat, and sweat causes the pores of the skin to open, reducing resistance and increasing the risk of electric shock. The humid environment of bathrooms is why they are classed as special locations.

Average person The mean between two extremes. As an example, some people have fairer skin than others, so their safe voltage level will be lower; whereas someone who works with hand tools has tougher skin on their hands, so has a higher resistance.

Azimuth Refers to the angle that the panel direction **diverges** from facing due south.

Bill of quantities A pre-prepared list of materials usually created by a quantity surveyor; replaces the take-off sheet.

Biomass The biological material from living or recently living organisms; biomass fuels are usually derived

from plant-based material but could be derived from animal material. Fuel pellets can be made from woodworking offcuts, cereals or grain products, oils, animal fats and waste fish products.

Blackwater Water that is contaminated to the point of no use and must be treated at a waste-water treatment facility. Sewage is classed as blackwater.

Blown In the context of fuses, when the element in the fuse has melted or ruptured due to excessive current.

Broadknife A tool rather like a wallpaper scraper but much more pliable.

BSO The British Standards Institution document that sets the rules for all BS documents such as BS 7671.

Building envelope The fabric of the building.

Calorific value Energy given off by burning.

Circuit installation conditions The conditions that require rating factors, such as C_a , C_g , etc.

Class II equipment Double insulated or reinforced insulated equipment, having the symbol



Combustion A chemical reaction between fuel, oxygen and an ignition source (e.g. matches). The fuel can be a gas, a liquid or a solid, such as wood or paper.

Competent person In the context of the Electricity at Work Regulations, the term competent person is used to describe the person who possesses skill and knowledge of the electrical systems and who can understand the dangers that may arise from them.

BS 7671 now defines that person as Skilled (electrically).

Composite cable Multi-cored, where the cores are surrounded by a sheath providing mechanical protection.

Conduit method This is a common name given to a system where the circuit is wired using single-core non-sheathed cables. They may be installed in trunking as well as conduit.

Critical path The sequence of key events and activities that determines the minimum time needed for a process, such as building a construction project.

Departure A situation where the regulations could not be complied with. For example, Section 701 of **BS 7671** states that socket outlets shall not be installed within 3 m of the edge of zone 1 of a shower tray. If the shower was in a leisure centre and a socket outlet was needed for cleaning purposes and it had to be installed 2 m from the shower, this would be a departure. As long as measures were taken to make it safe, this would be acceptable. These measures might be installing a key switch on the socket, so it can only be used by authorised people, and a risk assessment would show that the socket can only be used when the room is not in use.

Dissipate Providing the ground resistance around the electrode is suitable and the supplier's transformer is connected to the ground, sufficient current will be drawn to and into earth to disconnect a protective device.

Distribution circuit Unlike a final circuit, which supplies current-using equipment, a distribution circuit is the supply to a distribution board.

Diverges When something is off by an amount or differs

Diversity The assessment of the total electrical equipment or loading in use

at any one time within an installation. The designer will make this reasonable judgement based on knowledge of the expected operation of the installation.

Drop The amount of paper that is required to cover a strip from the ceiling to the floor.

Duty holder The person in control of the danger. This person must be competent by formal training and experience and with sufficient knowledge to avoid danger. The level of competence will differ for different items of work.

Earth fault loop impedance The impedance of the earth fault current loop starting and ending at the point of earth fault. This impedance is denoted by the symbol Z_s .

Efficacy The ratio of power in and power out, measured in two different units. For example, the ratio of light output in lumens to the electrical power measured in watts.

Efficiency The ratio between power in and power out, measured in the same unit.

Efficiency percentage The higher the percentage, the greater the efficiency.

Egress Exiting or leaving an area.

Electrical buyer The person who places the purchase orders with suppliers for electrical equipment. They are often required to source and negotiate deals to secure the best price and delivery for a wide selection of electrical accessories and components. Big discounts can be given by the supplier if the electrical buyer can place large orders.

Electrolyte A chemical solution that contains many ions. Examples include salty water and lemon juice. In major battery production, these may be alkaline or acid solutions, or gels.

Electromagnetic interference (EMI) The process of electromagnetic radiation interfering with sensitive electronic components. For example, when you turn a light switch on or off, a tiny arc occurs as the switch makes or breaks contact, resulting in electromagnetic interference.

Ethos The beliefs and approach of a group or institution.

Exposed conductive parts Parts of the electrical system that can easily be touched and have live parts within, such as metal cases housing wiring systems.

Extent The amount of inspection and testing. For example, in a third-floor flat with a single distribution board and eight circuits, the inspection will be visual only without removing covers and testing, and will involve sample tests at the final point of each circuit.

Extraneous conductive parts Parts that are not part of the electrical system but which may provide a path to earth, such as metal water pipes or the steel supports of a building.

Final temperature A cable's final temperature is the point at which the weakest part of the cable, usually the insulation, melts.

Flammability A measure of how easy it is for something to burn or ignite, causing a fire.

Flash point Refers to liquids that are **flammable**. Gases are **ignitable** and we use LEL and UEL to define limits when a gas will ignite or explode.

Foundation earth electrode Defined in **BS 7671** as a conductive part buried in the soil under a building foundation or, preferably, embedded in concrete of a building foundation, generally in the form of a closed loop.

Fundamental principles The basis of Chapter 13 of **BS 7671**; they are not just the foundations of BS 7671 but are the design principles a designer should work to. Section 132 and the

regulations within are considered as the designer's checklist.

Greywater Waste water from wash basins, showers, baths, kitchen sinks and washing machines.

Induction motor The induction motor is the simplest form of alternating current (AC) motor. It is also known as the asynchronous motor.

Initial verification The process of inspecting and testing an electrical installation for the first time, before it is put into service.

ISO 9000 A quality standard for management systems to ensure that organisations meet the needs of their clients while meeting all regulations.

Isolation The disconnection and separation of an electrical installation from every source of electrical energy in such a way that this disconnection and separation is secure.

JPEL/64 A committee made up of representatives of many electrical industry organisations, the names of which are all listed in the front of **BS 7671**.

Just in time A site term used to describe an approach to stock/goods control; a large-quantity order is placed with a supplier, with agreement on a staged delivery. This means that the total order is placed at the start, to take advantage of quantity discounts, but the supplier stores the materials and only delivers the required quantity at the agreed times throughout the project.

Kinetic energy Energy of motion; the movement of an object can do work (energy) on anything it hits or is connected to.

Limitation A part of the inspection and test process that cannot be done for operational reasons. For example, the main protective bonding connection to the water system, located in the basement, could not be

inspected as a key for the room was not available.

There are two types of limitations:

- Agreed limitations which are made before work begins. This may be, for example, where a certain safety circuit cannot be turned off.
- Operational limitations which are situations that arise during the work. This could be, for example, where a room was supposed to be inspected, but the person with the key was not available, so access was not possible.

Linked One switching action turns off all poles.

Livework Working on or near live parts.

Load shedding Where technology is used to monitor loading of the electrical supply and turns off any excessive loads that could be used at times of lower demand, such as washing machines.

Maximum demand The total demand of an installation at full load; the total consumption assuming everything is being used at the same time.

Maximum operating characteristic The time a device takes to complete the operation of disconnection – including pre-arcing time, arcing and disconnecting – leaving a gap big enough to prevent current flow. Manufacturers provide detailed graphs showing pre-arcing characteristics. Graphs in [BS 7671](#) only show maximum operating characteristics.

Selectivity will be achieved for fuses if an upstream device is more than twice the rating of any downstream device. For example, if the upstream fuse (A) has a rating of 80 A and the local downstream fuse (B) is 32 A, selectivity would be achieved as neither of the characteristic curves cross one another.

Mentor An advisor, counsellor or trainer who gives guidance and acts as a role model.

Methods of installation detailed in two ways:

- Reference methods, which are the letters given in the right-hand column of Table 4A2 in [BS 7671](#)
- Installation methods, which are the numbers on the left-hand side of the same table.

Most of the time when the term 'method' is used it refers to the letter, with the exception of flat-profile cables when they are installed above ceilings or in stud walls. In this situation, the Installation method number is used.

Microgeneration The small-scale generation of heat or electric power by individuals, small businesses and communities to meet their own needs, as alternatives or in addition to traditional, centralised, grid-connected power, such as power stations.

Microgeneration technologies Small-scale methods of generating electricity, such as solar photovoltaic, wind turbine and hydro.

Micro-renewable energy Small-scale generation of energy that is collected from renewable resources which are naturally replenished on a human timescale, such as sunlight, wind, rain, tides, waves and geothermal heat.

Multi-phase More than one phase. [BS 7671](#) sometimes uses the term polyphase to mean more than one phase.

Nominal An expected value but in reality the value is different. Nominal voltage to earth (U_0) in the UK is 230 V, so if you measure the voltage between line and earth, you should read 230 V. In reality, the voltage is likely to be higher than this or, in some cases, lower. It depends on where the installation is in relation to the substation transformer: the further

away, the more voltage is lost, so the lower the actual voltage. Voltage can also vary with demand: the more demand that is placed on a substation transformer, the lower the voltage will be.

As voltage can vary, a standard measurement is required that we can use in calculations. We use these nominal values:

- Nominal voltage to earth (U_0) = 230 V
- Nominal voltage (U) line to line or line to neutral = 400/230 V.

Non-statutory Not a legal document or requirement, but a good practice guide. See Section 114 of [BS 7671](#).

Not reasonably practical In this context, refers to something located in such a position that expensive or unavailable specialist equipment is needed to isolate it.

Overcurrent More current in a circuit than is intended.

Overheads Overheads are added to the labour costs as a percentage. Annual overheads should be calculated and divided into the expected hours worked annually to spread the cost of them over all works.

Permitted development Allows certain projects or building work to be carried out without the need for planning permission.

Photons Particles of energy from the Sun.

Practical completion Where a certificate is issued to verify all works have been undertaken as contracted.

Pre-arcing (time) The time taken for a device to react to an overcurrent, up to the point where the device breaks and arcs.

Protective extra-low voltage (PELV) Operates at extra-low voltage but may have a connection to earth.

Protective measures The methods used to protect against faults, with the most common being automatic disconnection of supply (ADS).

Purchase orders Official orders that usually have an order number which links the purchased equipment to a specific contract. Purchase orders have a detailed list of materials that are required, to eliminate the risk of incorrect equipment being purchased.

Rainwater Water captured from gutters and downpipes.

Rebars Steel bars used to reinforce concrete.

Residual hazards Residual hazards are unavoidable hazards that will exist once the contract is complete and should be identified for the client to take reasonable precautions, such as working at height, working with electricity, etc. Although these tasks would not normally be undertaken by the client themselves, unless they had on-site maintenance teams, they are identified in operation and maintenance manuals, so that others are aware of the risks before work starts.

Responsible person The person who is designated as the responsible person has delegated responsibility for certain aspects of a company's operational functions, such as fire safety, electrical operational safety or the day-to-day responsibility for controlling any identified risk, such as *Legionella* bacteria.

Rotor speed The actual speed at which the rotor rotates in revolutions/second (r/s).

Safely disconnecting In this situation we are considering if a device can disconnect without causing injury or damage, not about it meeting disconnection times.

Schedule of rates A document that lists a labour/time cost for installing

and connecting an individual item of equipment. Examples may be £2.50 to fix a ceiling rose securely to a plaster ceiling and £1.50 to connect the cable to it. Running the cable to the ceiling rose could be charged at a rate of £2.00 per metre.

Secure Achieved by locking off with a safety lock – such as a lock with a unique key. The posting of a warning notice also serves to alert others to the isolation.

Selectivity Previously called *discrimination*, this is where a device, such as a time-delay RCD used as a main switch, is selected to ensure that local devices trip first. If a problem persists, the time-delay RCD will trip, cutting the entire supply.

Semiconductor A material with resistivity that sits between that of an insulator and a conductor.

Separated extra-low voltage (SELV) The same as electrical separation but the voltage is extra low (< 50 V AC).

Service head (cut-out) The enclosure that the supply cable is terminated into before it tails to the meter.

Short circuits When a fault occurs between live conductors. The fault could be between line and neutral or, in the case of a three-phase circuit, line to line.

If an installation has been correctly designed and a circuit disconnects within the required time because the earth fault loop impedances meet those in Tables 41.2–41.4 of **BS 7671**, it could be considered that a circuit will also disconnect safely under short-circuit conditions.

There is no specified disconnection time for short circuits but the protective device must disconnect before the cable reaches its final limiting temperature; that is, the

temperature at which the insulation is melting and the cable is no longer adequate. If a short circuit were allowed to continue, the heat could also cause a fire.

Short shipments Occur when the supplier delivers an incomplete order. There are normally items on the original order still to be delivered, or the quantity is short and the balance is yet to come.

Slip The difference between the synchronous speed and the rotor speed expressed as a percentage or per unit value.

Soakaway A system where surface water or water from guttering is channelled into an area of ground that has been suitably prepared to allow the water to disperse in the ground without causing flood or damp issues.

Statutory Instruments Acts of Parliament that give powers to another body or organisation to act on those powers. The HSE are empowered under the Health and Safety at Work Act to enforce the Act on behalf of Parliament.

Step-down transformer A transformer that has a proportionally higher number of turns on the primary than on the secondary.

Step-up transformer A transformer that has a proportionally higher number of turns on the secondary (output stage) than on the primary (input stage).

Suitable In this context means that a device can safely disconnect the fault without blowing up or, in the case of a circuit breaker, having the contacts weld together.

SWOT analysis The assessment of Strengths, Weaknesses, Opportunities and Threats.

Synchronous speed The speed at which the rotating field rotates around the field poles.

Take-off sheet A list detailing the number and scope of items needed per area of installation.

Technical specification A technical document giving concise details of the client's wishes and expectations.

Tender An offer to carry out work for a certain amount of money, in accordance with a particular contract.

Undervoltage A reduction or loss of voltage; quite simply, a power cut.

BS 7671 requires undervoltage protection on any machine where the sudden re-starting of the machine may cause a danger. Using motor controls that require somebody to manually switch the machine back on after a power cut provides undervoltage protection.

Variation order A declared change to the original contract.

Water bowser A transportable water tank or tanker.

Wholesome water Water that is palatable and suitable for human consumption; the water that is obtained from the utility company supply and is also known as 'potable' and 'white water'.

Common acronyms

The following are some acronyms commonly used in electrical industries for installation, maintenance and design work.

AATF	approved authorised treatment facility	CHP	combined heat and power	ECS	Electrotechnical Certification Scheme
AC	alternating current	CNE	combined neutral/earth	EFLI	earth fault loop impedance
ADS	automatic disconnection of supply	CO ₂	carbon dioxide	EIC	Electrical Installation Certificate
AE	approved exporter	COP	coefficient of performance	EICR	Electrical Installation Condition Report
AFDDs	arc fault detection devices	COSHH	Control of Substances Hazardous to Health	emf	electromotive force
ASHPs	air-source heat pumps	cpc	circuit protective conductors	EMI	electromagnetic interference
AVI	approved voltage indicator	CPM	critical path method	EN	European Standard
BS	British Standard	CRIS	Condition Report Inspection Schedule	ESA	environment site audit
BSI	British Standards Institute	CRT	carbon-reduction technologies	ESQCR	Electricity Safety, Quality and Continuity Regulations
C	capacitance	csa	cross-sectional area	EVC	emergency voice communication
CB	circuit breakers	CSCS	Construction Skills Certification Scheme	F	measured in farads
CCTV	closed circuit TV	CT	current transformer	F	fluorinated
cd	candela	CU	consumer unit	ffl	finished floor level
CDM	Construction (Design and Management) Regulations	DB	distribution board	GLS	general lighting service
CEGB	Central Electricity Generating Board	DC	direct current	GN	Guidance Note
CENELEC	Comité européen de normalisation en électronique et en électrotechnique; European Committee for Electrotechnical Standardization	DG	distributed general	GSHPs	ground-source heat pumps
CF	compact fluorescent	DG	Distributed Generation	HAWT	horizontal-axis wind turbine
		DNO	distribution network operator	HBC	high-breaking capacity
		DOL	direct online	HDs	harmonised documents
		DSEAR	Dangerous Substances and Explosive Atmospheres Regulations	HID	metal halide
		DTC	differential temperature controller	HRC	high-rupturing capacity
		EA	the Environment Agency	HSE	Health and Safety Executive
		EAWR	the Electricity at Work Regulations	HSWA	the Health and Safety at Work Act
				IDNO	independent distribution network operator

IEC International Electrotechnical Commission	MCCBs moulded-case circuit breakers	PV photovoltaic
IET Institution of Engineering and Technology	MCS Microgeneration Certification Scheme	RCBOs residual current breakers with overload
IM insulation monitors	MEIWC Minor Electrical Installation Works Certificate	RCD residual current device
IP ingress protection	MET main earthing terminal	RCMs residual current monitors
IP international protection	MI mineral-insulated	SELV separated extra-low voltage
IPS isolated power supplies	MICC mineral-insulated copper-clad cable	SON high-pressure sodium
IT impeded earth	MPB main protective bonding	SOX low-pressure sodium
IT information and technology	MW megawatts	SPDs surge protection devices
kW kilowatts	OSG On-Site Guide	SWA steel-wire armoured
LABC Local Authority Building Control	PEFC prospective earth fault current	UEL upper explosive limit
LED light-emitting diode	PELV protective extra-low voltage	UPS uninterrupted power supply
LEL lower explosive limit	PEN protective earthed neutral	UV ultraviolet
lm lumen	PFC prospective fault current	VAWT vertical-axis wind turbine
LPG liquid propane gas	PLCs programmable logic controllers	VFD variable frequency drive
lux lumens per metre ²	PME protective multiple earthing	VL line voltage
m/s metres per second	PPE personal protective equipment	VO variation order
m ³ /s cubic metres per second	PSCC prospective short-circuit current	VP phase voltage
MBFU high-pressure mercury	PTW permit to work	VT voltage transformer
mCHP micro-combined heat and power	PUWER the Provision and Use of Work Equipment Regulations	WEEE the Waste Electrical and Electronic Equipment Regulations
MCCBs miniature circuit breakers		WRAS Water Regulations

Formula sheet

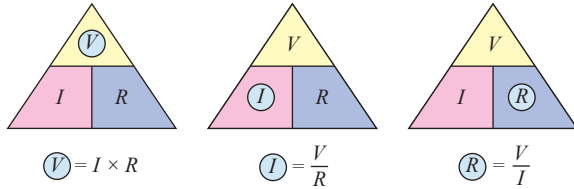
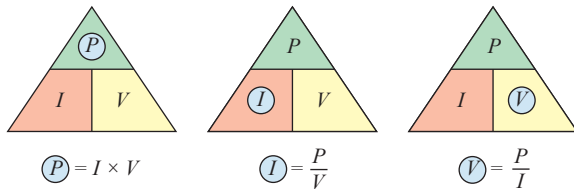
Subject	Formula	Where to find it
Ohm's law		Revision from Book 1
Power		Revision from Book 1
Resistances in series	$R_{total} = R_1 + R_2 + R_3 \dots$	Revision from Book 1
Resistances in parallel	$\frac{1}{R_{total}} = \frac{1}{R_1} + \frac{1}{R_2} + \frac{1}{R_3} \dots$	Revision from Book 1

Subject	Formula	Where to find it
Resistivity	$R = \frac{\rho L}{A}$	Revision from Book 1
Three-phase star connections	$I_L = I_P$ and $V_P = \frac{V_L}{\sqrt{3}}$ or $V_L = V_P \times \sqrt{3}$	Chapter 2 page 73
Three-phase delta connections	$V_L = V_P$ and $I_L = I_P \times \sqrt{3}$ or $I_P = \frac{I_L}{\sqrt{3}}$	Chapter 2 page 75
Three-phase neutral current	$N = \sqrt{L_1^2 + L_2^2 + L_3^2 - (L_1 \times L_2) - (L_1 \times L_3) - (L_2 \times L_3)}$	Chapter 2 page 107
Transformer ratios	$\frac{N_p}{N_s} = \frac{V_p}{V_s} = \frac{I_s}{I_p}$	Chapter 2 page 82
Inductive reactance in AC circuits	$X_L = 2\pi fL$	Chapter 2 page 86
Capacitive reactance in AC circuits	$X_C = \frac{1}{2\pi fC}$	Chapter 2 page 88
Impedance in AC circuits	$Z = \sqrt{R^2 + X^2}$ Note: X is either X_L or X_C . Where the circuit has both components, take the smallest value from the largest to obtain X	Chapter 2 page 89
Current in AC circuits	$I = \frac{V}{Z}$	Chapter 2 page 91
Power triangle	$kVA = \sqrt{kW^2 + kVA_r^2}$	Chapter 2 page 98
Power factor	$\cos \theta = \frac{R}{Z}$ and $\cos \theta = \frac{kW}{kVA}$	Chapter 2 page 100 Chapter 2 page 103
Rotor speed	$n_r = n_s - \frac{n_s \times \text{slip}\%}{100}$	Chapter 2 page 118
Synchronous speed	$n_s = \frac{f}{p}$	Chapter 2 page 118
Inverse square law	$E = \frac{I}{d^2}$ (lux)	Chapter 2 page 138
Inverse cosine law	$E = \frac{I}{h^2} \times \cos \theta$ (lux)	Chapter 2 page 140

Subject	Formula	Where to find it
Lumen method	$N = \frac{E_{\text{average}} \times \text{Area}}{\text{Mf} \times \text{Uf} \times F}$	Chapter 2 page 143
Efficacy	$\text{efficacy} = \frac{\text{lumens}}{\text{watts}}$	Chapter 2 page 145
Adiabatic equation	For short circuit protection $t = \frac{k^2 \times S^2}{I^2}$ For determining csa of a cpc $S = \frac{\sqrt{I^2 \times t}}{k}$	Chapter 3 page 196 Chapter 3 page 213
Design current (I_b)	$I_b = \frac{\text{watts}}{\text{volts}}$ $I_b = \frac{\text{watts} \times 1.8}{\text{volts}}$ $I_b = \sqrt{3} \times V_L \times \cos \theta$	Chapter 5 page 293
Minimum conductor csa	$I_t \leq \frac{I_n}{C_a C_g C_i C_s C_d C_c}$	Chapter 5 page 294
Voltage drop	$V = \frac{\text{mV/A/m} \times L \times I_b}{1000}$	Chapter 5 page 295
Max mV/A/m	$\text{max mV/A/m} = \frac{\text{max volt drop} \times 1000}{I_b \times \text{length}}$	Chapter 5 page 301
Minimum current capacity I_z	$I_z = I_t \times C_a \times C_g \times C_i \dots$	Chapter 5 page 302
$R_1 + R_2$	$R_1 + R_2 = \frac{\text{m/m} \times \text{length} \times f_{\text{temp}}}{1000}$	Chapter 5 page 305
Earth fault loop impedance	$Z_s = Z_e + (R_1 + R_2)$	Chapter 5 page 306

Answers

CHAPTER 1

- 1 **D** Part E contains the specific requirements for resistance to the passage of sound.
- 2 **B** Solar collectors are used in this system to heat a fluid which, in turn, heats the water.
- 3 **D** Slinkies are laid in the ground to maximise contact in ground-source heat pump systems.
- 4 **A** Food waste is one of the materials which is burned to create energy.
- 5 **C** Systems not connected to the general electricity supply (feed in) are classed as off-grid systems.
- 6 **C** Inverters convert DC to AC, while rectifiers convert AC to DC.
- 7 **A** Optimum output is gained from arrays that are facing south and tilted to an angle between 30° and 40°.
- 8 **B** As wind turbines rotate, they create moving shadows. This is known as shadow flicker.
- 9 **C** The penstock is the name given to the pipework that takes water from the forebay to the turbines linked to the generator.
- 10 **D** Combined heat and power systems use one fuel source to heat the property and generate electricity, and are commonly referred to as CHP systems.
- 11 Answers may include:
 - for flushing toilets
 - for washing vehicles
 - for watering the garden
 - for the operation of washing machines
 - other suitable uses.Harvested rainwater is not suitable for food preparation, consumption or personal hygiene uses.
- 12 The PV array must be facing as southerly as possible with a tilt angle between 30 and 40° and in a position not shadowed by structures or trees.
- 13 The general components include:
 - solar collector
 - differential temperature controller
 - circulating pump
 - storage cylinder
 - auxiliary heat source.
- 14 Part A gives requirements for the structure of the building and so consideration needs to be given to the weight of the array and whether the building is capable of supporting the array. The type of fixing needs to be compatible with the building, such as tiles not being suitable to support the array. A further consideration is spacing from the structure, owing to the potential heat produced by the array.
- 15 Permitted development is where certain buildings, structures or extensions/additions to buildings are allowed without obtaining planning permission from the local authority. An example would be a PV array that does not extend the existing roof height by more than 200 mm.
- 16 **B** An evacuated-tube collector is found in solar thermal systems where solar energy is absorbed by the tube creating a thermal transfer.
- 17 **C** Ground-source heat pumps use F gas as the medium for heat transfer in the refrigeration cycle.
- 18 **A** Wholesome water means the water is suitable for drinking.
- 19 **D** Approved Document S sets out requirements for the provision of electric vehicle charging circuits.
- 20 **A** An air-source heat pump can produce around 3 kW heat output compared to an input of just 1 kW.
- 21 **B** Buffer tanks are used to store excess heat produced by an air or ground-source heat pump.
- 22 **D** The compressor squeezes the gas increasing its pressure and therefore increases its temperature. Whilst the refrigerant is heated by the ground or outside air, the refrigerant is not a gas at this point but becomes a gas when initially heated.
- 23 **C** In the UK, the best tilt angle to capture the Sun all year round is 30° to 40°.
- 24 Planning consent may be needed where an addition to a building extends beyond the current roofline. For example, if a PV system is mounted on a flat roof, the roof line changes. Also, if a building is listed or in a conservation area, it will require planning consent to alter this too.
- 25 Wind turbines are best situated on hills where the ground rises gradually. A steep cliff causes the wind to become turbulent, meaning it flows

in many directions, minimising its strength in one particular direction.

- 26 The boiler doesn't just produce heat by burning fuel, such as gas, but also utilises the energy to generate electricity using a Stirling engine/generator.
- 27 Two disadvantages may include:
- noise – the outside unit can be noisy and if located near neighbouring houses, could be considered a noise nuisance.
 - they are not always compatible with or suitable for retrofitting, as radiators may need to be enlarged due to the lower heat that will be generated.

Other suitable answers such as initial costs, less efficient in winter, need a defrost cycle.

CHAPTER 2

- 1 C 33 kV forms part of the distribution network. 400 kV and 275 kV are transmission voltages and 25 kV is a generating voltage.
- 2 A Three-phase supply systems in the UK have a line voltage of 400 V and a phase voltage of 230 V.
- 3 D When all three phases are balanced, no current will flow in the neutral of the system.
- 4 B By laminating the core using thin, insulated sections to construct the core, eddy currents, which create heat, are minimised.

5 B The current is determined by $\frac{400}{230} = 1.74 \text{ A}$

6 C $2\pi \times 50 \times 12 \times 10^{-3} = 3.77 \Omega$

7 B $\frac{1}{2\pi \times 25 \times 200 \times 10^{-6}} = 31.8 \Omega$

And

$$\frac{100}{31.8} = 3.14 \text{ A}$$

- 8 C kW represents true power.
- 9 D An induction motor has a rotor that isn't electrically connected, and current is induced into the rotor.
- 10 D Lux is the unit of measurement for illuminance.

- 11 Approximately 53 A would be present in the neutral conductor and this may be determined by:
- calculation
 - phasor
 - equilateral triangle.
- See page 106 for methods.

12

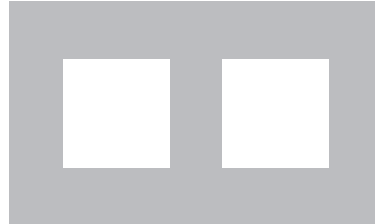

Shell core shape

13 $\frac{6}{0.5} = 12$ so 12:1 ratio

And

$$\frac{230 \times 0.5}{6} = 19.2 \text{ V}$$

14

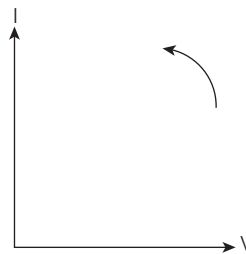

Phasor showing current leading voltage by 90°

15

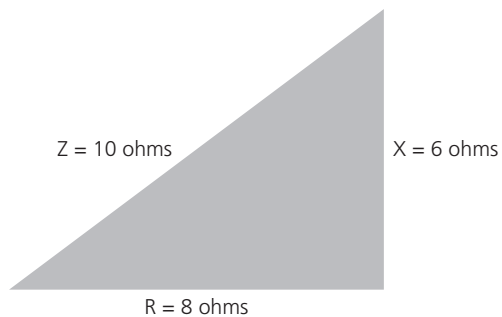

Scaled triangle resulting in an impedance (Z) of 10 Ω

16 $\frac{90}{3^2} = 10 \text{ lux}$

- 17 It is a measure of the output of a lamp when compared with the power input measured in lumens/watt.
- 18 The capacitor is required for starting the motor. Once the motor is running, the capacitor is not required, so a centrifugal switch opens the circuit to the capacitor when the motor rotates.
- 19 The heater heats air; the heated air rises into the room and falls when cool. As heat rises, the cooler air below is drawn into the heater.

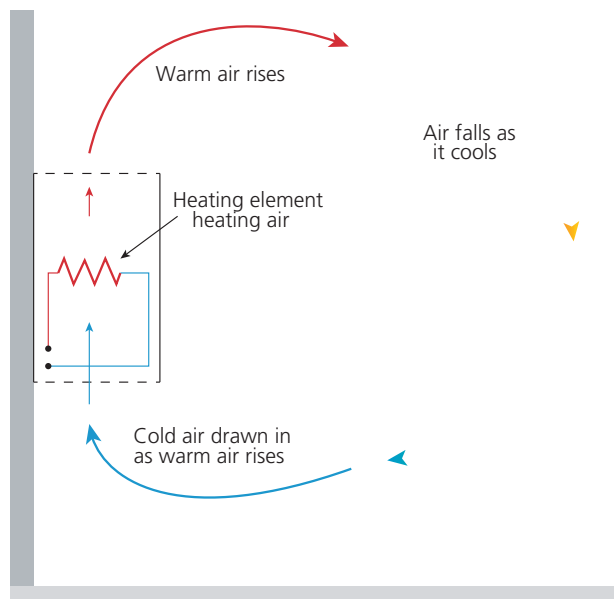

- 20 At off-peak (cheaper) times, elements heat bricks which store the heat. Heat is then used during the day when energy costs are higher.
- 21 **C** Magnetic flux needs to cut across a conductor at 90° to induce the maximum current. While flux at 45° may induce a current, the induction will not be as effective and therefore less current will be induced. Flux running with a conductor at 0 and 180° will not induce current.
- 22 **B** The term that describes the sharing of electricity between two nations/countries is interconnected capacity.
- 23 **C** Wood is classed as a biomass fuel whereas gas, coal and oil are all fossil fuels.
- 24 **B** An electrolyte, which is a chemical solution such as alkaline, is used to separate two metals in cells making batteries.
- 25 **C** Each phase in a three-phase system is separated by 120° .
- 26 **A** A current transformer (CT) surrounds a conductor and the magnetic field induced by it. The flux induces a current in the transformer relative to the current in the conductor, but much lower so it can be read by the ammeter proportionately.
- 27 **C** The efficacy of a lamp is measured in lumens per watt.
- 28 **B** Conduction is the main method of transferring heat from the immersion heater to the water. The water does then move in the same way as air through a convection heater.
- 29 Water from a lake high up on a mountain is released to turn turbines connected to generators. At night, when consumption is low, the water is pumped back up to the lake ready for immediate use when needed.
- 30 In a delta system, the line voltage is the same as the phase voltage so, using Ohm's law, the phase current in each phase is
- $$\frac{400}{20} = 20 \text{ A}$$
- In a delta system,
- $$I_L = I_p \times \sqrt{3}$$
- So
- $$20 \times \sqrt{3} = 34.64 \text{ A per line.}$$
- 31 Series arc – when a conductor or joint becomes loose, creating a casual open circuit where arcs jump between.
Parallel arcs – when an insulation fault causes arcing between two different conductors.
- 32 The power to the boiler and pump is diverted through the microswitch in the valve as the switch will only close, completing the circuit, when the valve has completely opened. This ensures the pump does not try to pump against a closed valve. See Figure 2.132.

CHAPTER 3

Activity (page 215)

The MPB must be at least half the csa of the incoming conductor to a minimum of 6 mm^2 , so half of 16 is 8. As you cannot get an 8 mm^2 cable, a 10 mm^2 conductor must be used.

Answers in this section will simply contain chapter or section numbers within **BS 7671: 2018 (2022)** The IET Wiring Regulations, 18th Edition, so you can research the answers if you were incorrect.

- 1 C 110.2
- 2 A 132.7
- 3 B Definitions: Part 2
- 4 D Abbreviations table in Part 2
- 5 C 331.2
- 6 A 331.1
- 7 C Chapter 41; contents page shows insulation as a form of basic protection. See 416
- 8 C 411.3.1.2
- 9 D 411.3.2.3 as fixed equipment rated over 32 A does not need to comply with 411.3.2.2 and therefore Table 41.1
- 10 B 411.3.3 or 415
- 11 C Table 41.2 as this circuit must disconnect in 0.4 seconds
- 12 C Table 41.5
- 13 D 411.8.3
- 14 C 416.2.2
- 15 A 422.4.2
- 16 B 434.5.2; equation and k value from Table 43.1
- 17 D Table 537.4
- 18 B From Table 54.3; as the cpc is incorporated in cable
- 19 C 701.512.3
- 20 D Appendix 3 Fig 3A2(a)
- 21 D Regulation 110.1.3 item (ix) specifically mentions lightning protection systems as being excluded from the scope, whereas the other options are all within the scope of BS 7671 in regulations 110.1.1 or 110.1.2.
- 22 A Unless you know the answer to this, you will need to look up each word in Part 2: Definitions within BS 7671 until you see the definition that matches the wording of the question.
- 23 D The answer is found in the symbols section of BS 7671 towards the end of Part 2: Definitions.
- 24 B I refers to isolated. The types of earthing arrangements are described in regulation 312.2.
- 25 C The clue in this question is 'where a particular risk of fire exists' and as the question relates to fire, check the contents page for Chapter 42 where you will see this is the wording used for section 422.3. Regulation 422.3.9 is where wiring system requirements are given in these locations and here, a maximum 300 mA RCD is permitted to protect cables other than mineral insulated ones.
- 26 A Table 42.1 in Chapter 42: Protection against thermal effects, gives maximum temperature limits for accessible parts of equipment.
- 27 C Chapter 44 and in particular Section 444 deals with electromagnetic disturbances. In particular, 444.6 deals with segregation and within 444.6.2, 130 mm is given as the minimum segregation distance.
- 28 A 2022 is pink. Before 2022 it was cream. As the cable is new, it must be to the current edition.
- 29 B Selection and erection is Part 45 and Chapter 53 deals with the selection of devices for protection control isolation and switching. Section 531.3 deals with RCDs and in particular, 531.3.2 deals with Unwanted Tripping where a value of 30% is given.
- 30 B During an initial verification (Chapter 64) insulation resistance tests values should be in accordance with Table 64 where a value of 1 M Ω is given.
- 31 B Appendix 4 contains tables with rating factors that should be applied when determining the current-carrying capacity of a conductor. The table in Section 2.6 gives the rating factors based on the length the thermal insulation totally surrounds the cable. In previous editions of BS 7671, this table was in Chapter 52.
- 32 C All BS and BS EN numbers that are featured in BS 7671 are listed, in numeric order, in Appendix 1 with a description of what they apply to.

CHAPTER 4

Activity (page 234)

It is a Star/Delta starter and works by closing contacts KM3 and KM1 first, placing 230 V across the windings of the motor to enable starting of the motor. After a short period of time, KM1 drops out and KM2 closes placing 400 V across the motor.

- 1 C It is the responsibility of the contractor to hand over safety certification to the client on completion of work.

- 2 **B** Schematic diagrams show the sequence of control.
- 3 **A** A residual hazard is an unavoidable hazard relating to installed equipment. The hazard must be identified in an operation manual, under Construction Design and Management Regulations.
- 4 **D** A take-off sheet is used to help determine the quantity of accessories on the contract drawings.
- 5 **B** A provisional sum is estimated where there is minimal information relating to a specific item of equipment, meaning that detailed installation costs cannot be worked out.
- 6 **B** Changes to the original contract require the issue of a variation order.
- 7 **C** Toilets are an essential facility for any place of work, including construction sites.
- 8 **A** Where items are missing from an order and will be delivered at a later time, this is called a short shipment.
- 9 **B** Where defects are found on the existing part of an electrical installation, they should be recorded on either the Electrical Installation Certificate (EIC) (not given as an option in the question) or an Electrical Installation Condition Report (EICR).
- 10 **B** Egress is a safe means of being able to leave a building or site.
- 11 Where there is a risk of serious personal injury, the inspector can stop the activity immediately or after a specific period. The activity cannot be resumed until remedial action has taken place to make a situation safe.
- 12 A critical path shows the tasks to be performed and in what order they should be completed. It can be used to indicate potential problems in the work programme.
- 13 Answers may include:
- wearing overshoes
 - putting down floor matting
 - putting down dust sheets
 - changing routes.
- Other similar answers are acceptable.
- 14 A pre-work survey is undertaken to assess and document any existing damage that might be present on a site, so the client cannot blame the damage on works carried out.
- 15 Descriptions may be on the following areas of consideration:
- ease of delivery
 - security
 - ease of getting materials to point of use
 - avoiding areas of construction.
- 16 **D** The finish of a product is the type of material and/or colour such as white, brass, Victorian brass etc.
- 17 **C** As a wholesaler stocks products from many different manufacturers, their literature has the advantage of showing them all for comparison.
- 18 **C** A scale of 1:50 means that 1 mm on the drawing is 50 mm in reality.
So $250 \text{ mm} \times 50 = 12\,500 \text{ mm}$ or 12.5 m
- 19 **C** Documents relating to the final installed work should be in an O&M manual including certification.
- 20 **B** ISO 9000 is a quality standard which is achieved by organisations who have proven that they meet the needs of the client whilst meeting all regulations.
- 21 **A** The system of ordering materials to arrive just as they are needed is known as 'just in time'.
- 22 **C** Options a and b are expensive and time-consuming when all that is needed is to isolate a circuit. Option d is not considered safe as footwear is a part of PPE and should not be removed.
- 23 **A** Certification is issued during the handover stage when all works are complete and in compliance.
- 24 An estimate is a guide towards the cost of works based on nothing unexpected happening whereas a quotation is a fixed agreed price.
- 25 Building information modelling can provide a 3D virtual reality tour or image of a building, internally or externally, before it is built. This enables a client to change specifications before work is undertaken.
- 26 Answers may include examples of three of the following.
- Be helpful even if a request is beyond your abilities.
 - Ask for feedback and act on it.
 - Know your products and work.
 - Create a great first impression.
 - Plan and inform.
 - Be proactive, not reactive.

- 27 Overhead costs should include all hidden costs of operating a company which includes the costs of items such as insurances, vehicle maintenance or transportation, support staff, offices and other suitable costs.

CHAPTER 5

- 1 **B** Chapter 13 contains the fundamental principles.
 2 **B** 0.35 Ω is the maximum declared value of Z_e .
 3 **C** A location plan is required information on an application for supply.
 4 **A** The maximum voltage drop for lighting is 3% of 230 V = 6.9 V. If the distribution circuit loses 3 V, that leaves 3.9 V for the final circuit.
 5 **D** External influences are the major factors to be considered when selecting wiring systems.
 6 **D** Type D circuit breakers can tolerate the highest inrush currents common with high inductive loads.
 7 **A** Selectivity is coordination between protective devices, ensuring the local device disconnects first.

8 **A**

$$\frac{11 \times 24 \times 14}{1000} = 3.7 \text{ V}$$

9 **C** From Table 4B1, the factor is 1.03

10 **B**

$$\frac{16000}{230} = 69.6 \text{ A}$$

Then $69.6 - 10 = 59.6 \text{ A}$

Then $59.6 \times 0.3 = 17.9 + 10 = 27.9 \text{ A}$

11 a $\frac{7200}{230} = 31.3 \text{ A}$

b 32 A

c B (Table 4A2)

d 0.94 (Table 4B1)

0.8 (Table 4C1)

e $\frac{32}{0.94 \times 0.8} = 42.55 \text{ A}$

Using Table 4D1A column 4 = 10 mm²

Table 4D1B – 10 mm² = 4.4 mV/A/m, so

$$\frac{4.4 \times 28 \times 31.3}{1000} = 3.86 \text{ V}$$

Less than 11.5 V, so acceptable

f 10/10 from Table I1 – 3.66 mΩ/m

Table I3 factor – 1.2 so

$$\frac{3.66 \times 1.2 \times 28}{1000} = 0.13 \text{ Ω}$$

g 0.17 + 0.13 = 0.3 Ω

- 12 **D** The cables connecting the service head to the meter, then the meter to the CU are known as tails.
 13 **B** The type of circuit that uses one cable to supply current-using equipment is a radial-final circuit.
 14 **A** A distribution circuit is one that supplies a distribution board (DB) or consumer unit (CU). Final circuits supply current-using equipment.
 15 **C** Section 314 of BS 7671 states that an installation should be divided into circuits to minimise inconvenience in the case of a fault.
 16 **C** Appendix 3 of BS 7671 contains time/current characteristics for protective devices.
 17 **C** Where a conductor has a steady load current less than 30% of the conductor's full current capacity, it can be ignored for grouping as it will not heat up significantly.
 18 **B** Table 4A2 of BS 7671 gives all the reference methods for all the different wiring systems and surface conduit is designated as B.
 19 **A** When the rating factors for circuit conditions are applied to the tabulated current capacity of a cable as multipliers, the result is known as I_z which is the current capacity of the given cable under those conditions.
 20 Equipment such as distribution boards uses the following descriptions.
 - Ways – the number of circuits the board can supply.
 - Modules – combination of components that can be fitted to the board depending on how many modules it can take. A double pole main switch for example takes two modules and a circuit breaker is usually a single module.
 21 The factor from Table 4B1 of BS 7671 is 0.79. This essentially means that the increase in temperature reduces the cable capacity to 79% or reduces capacity by 21%.

- 22 From Table I1 of the IET On-site Guide, a value of $m\Omega/m$ for this conductor combination is 16.71 $m\Omega/m$. From Table I3, the factor for a cable where the conductors are all incorporated is 1.2 so

$$\frac{16.71 \times 32 \times 1.2}{1000} = 0.64 \Omega$$

- 23 A low earth fault loop impedance means that, under earth fault conditions, a high fault current is induced, and disconnection occurs rapidly. If EFLI values were allowed to increase, disconnection times would be increased to dangerous levels.

CHAPTER 6

- 1 **D** All defects must be made good and re-tested before an Electrical Installation Certificate (EIC) is issued.
- 2 **B** Only by physically touching the terminal will a loose terminal be revealed. Terminals may be detected using smell or hearing (arcing) but a new installation should not be live at this point.
- 3 **B** During step 1 of a ring-final circuit test, the continuity of line conductor is recorded as r_1 .
- 4 **A** When the basic protection by barriers and enclosures is being verified, the level of ingress protection is checked to ensure that all surfaces provide IP protection.
- 5 **B** Before each use, to ensure readings are accurate, an inspector using a low-resistance ohmmeter should always zero the leads. Each time leads are changed or adaptors used, these too must be checked for resistance and, where necessary, nulled/zeroed.
- 6 **C** Insulation resistance testers test using a DC voltage. The typical voltage ranges are 250 V, 500 V and 1000 V.
- 7 **A** A test at $0.5 \times I_{\Delta N}$ is carried out to ensure the device does not trip. This ensures the device is not too sensitive.
- 8 **D** In order to comply with the requirements for additional protection, the RCD must trip within 300 ms when tested at one times its residual current setting.
- 9 **C** The test measures the maximum fault current, and protective devices are verified to ensure they are suitable to disconnect that current safely.
- 10 **C** It is the responsibility of the designer to set the interval between the initial verification and the first periodic inspection and test.
- 11 Continuity of cpc; insulation resistance; polarity.
- 12 As the circuits are in parallel to each other:

$$\frac{1}{10} + \frac{1}{10} + \frac{1}{5} = \frac{1}{0.4} = 2.5 M\Omega$$
- 13 From BS 7671 Table 42.3, the max tabulated $Z_s = 1.37 \Omega$
As this is at operating temperature and the test was not:
 $1.37 \times 0.8 = 1.10$, so 0.9 is acceptable
- 14 Details of test instruments are listed on a schedule of test results so that the instruments are fully traceable. If the instruments are found to be inaccurate, tests done using those instruments can be rechecked.
- 15 By pressing the test button, the client checks that internal mechanical parts activate and therefore do not stick.
- 16 **A** The Electricity at Work Regulations require a person undertaking inspection and testing to be competent. Option b is not specific in terms of competence and options c and d are not statutory.
- 17 **B** IET Guidance Note (GN) 3 is specific to the inspection and testing process.
- 18 **D** A Minor Works Certificate should only be used for the addition or alteration to an existing circuit.
- 19 **A** The minimum level of IP protection for any surface (except for accessible horizontal top surfaces) must have at least IP2X protection as Section 416 of BS 7671. IPX2 refers to drops of water.
- 20 **A** The 'dead' tests must be undertaken in a given order as stated in Regulation 643.1 of BS 7671. As the lighting circuit is not a ring-final circuit, that test is not applicable so the correct sequence would be tests 2 (continuity of protective conductors), 1 (insulation resistance) and 3 (polarity). Test 5 is a live test.
- 21 **D** When a circuit is extended, the resistance will increase. If the circuit is doubled in length, so will its resistance.

- 22 **B** Guidance Note 3 states that an allowance of approximately 0.05Ω should be made for the clamp onto the pipe when verifying a resistance test result by calculation of the conductor resistance based on csa and length.
- 23 **C** One approved method used to establish three-phase PFC is to double the highest single-phase value. As this was 1.35 kA, when doubled it is 2.7 kA.

24 Step 2 expected results

$$\frac{0.4 + 0.4}{4} = 0.2 \Omega$$

Step 3 expected results

$$\frac{0.4 + 0.67}{4} = 0.27 \Omega$$

25 Resistance is proportional to the difference in csa so

$$\frac{1.5}{2.5} = 0.6$$

So

$$1.61 \Omega \times 0.6 = 0.97 \Omega$$

So R_2 would be 0.97Ω (meaning the R_1 value would be the remainder – 0.64Ω).

- 26 When earth fault loop impedance is to be measured directly, all earthing and bonding must be connected in place. When $R_1 + R_2$ is measured, parallel paths through mechanical services are likely to be disconnected. So when EFLI is measured directly live, the parallel paths through other services will reduce the value.
- 27 To determine suitability of the results, first find the average

$$\frac{46 + 44 + 47}{3} = 45.67 \Omega$$

So $\pm 5\%$ of the average is

$$45.67 \times 1.05 = 47.96 \Omega$$

$$45.67 \times 0.95 = 43.38 \Omega$$

So all values measured must be within the two tolerances of $\pm 5\%$ and as they fall in between these readings, the ground resistance is stable. The average of 45.67Ω is recorded on documentation.

CHAPTER 7

- 1 **B** The **most** likely fault that has caused the continuous operation of a protective device in this particular location is damage to a concealed cable, as it is likely that the cable was damaged by a drill or fixing.
- 2 **B** When a circuit is overloaded, the thermal part of a circuit breaker will operate after several minutes. Once the circuit breaker cools, it can be re-set and will then trip again if the overloading continues.
- 3 **A** Equipment that has capacitors fitted must be discharged before working on it. The capacitors store a charge that can be released, causing electrocution if contact is made with the equipment terminals.
- 4 **C** With the symptoms described and no loads connected, the most likely fault is an insulation fault between line and earth or line and neutral.
- 5 **A** This result would show the resistance of the line and cpc when the circuit was considered healthy, so any open circuit or deterioration could be identified.
- 6 **A** Circuits must always be proven dead and securely isolated **before** any work is undertaken, even if you think the circuit is dead because the circuit breaker has disconnected.
- 7 **A** A C1 code indicates that a danger is present.
- 8 **B** GS38 applies to any test instruments used to measure or produce a voltage above 50 V AC.
- 9 **C** The length of time the equipment is out of action ultimately affects the decision, depending on which is quicker/cheaper.
- 10 **C** Waste Electrical and Electronic Equipment Regulations (WEEE) control the disposal of electrical waste products.
- 11 Answers include:
 - max 4 mm exposed tips
 - finger guards fitted
 - fused
 - colour identification
 - shrouded terminals for connection to instrument.
- 12 If the test method used was the $R_1 + R_2$ method with a temporary link and, during testing, switches or single-pole devices were operated, the meter

should read open/closed to confirm the line is switched and not the neutral.

- 13** If any machine were connected and the sequence was incorrect, the machine could rotate in the incorrect direction, causing potential damage.
- 14** IT equipment may leak current to earth during normal operation and too much equipment may be detected as a fault by an RCD.
- 15** A limitation is where, due to operation or logistical problems, some inspections or tests cannot be undertaken, such as a locked door stopping access to equipment.
- 16** **C** Clearly communicating to a client about times of isolation or disruption will lead to less inconvenience to the client.
- 17** **D** The person who is control of the installation and therefore is responsible for the safety and welfare of those around the installation is the Duty Holder.
- 18** **A** The HSE produce GS38 which gives guidance on test instruments and leads used on systems above 50 V AC or 120 V DC.
- 19** **A** An Electrical Installation Condition report is used to report on the condition of an existing electrical system.
- 20** **B** A C2 code means potentially dangerous. The circuit is not an immediate risk but would be if something else went wrong such as an earth fault developing in a luminaire.
- 21** **B** Cables that are within a roof space (other than an accessible loft) are outside the scope of an inspection.
- 22** **C** A low resistance ohmmeter is used to test for continuity safely and therefore would be most suitable.
- 23** **C** The voltage that should be measured on a healthy 230 V single-phase circuit should be
Line – Neutral – 230 V
Line – Earth – 230 V
Neutral – Earth – 0V
- 24** The extent of a report means precisely what parts of an electrical installation are included in the report. Some buildings may have several electrical systems so it is important to document exactly what is being covered.
- 25** The two main risks are:
- The risk of contact with corrosive acids such as sulphuric acid. Leaks or spills can cause serious harm.
 - Shock/explosion with stored energy. Battery systems can hold a huge charge that can be released quickly causing an explosion which can also ignite explosive gases emitted by the batteries under normal charging conditions.
- 26** An Uninterrupted Power Supply (UPS) maintains power to a circuit when the supply is lost, such as when someone isolates a circuit to work on it. The circuit may be energised still even though the person thinks it is safe to work on.
- 27** The most likely answers include:
- inside old semi-enclosed fuse carriers
 - older plaster boarding such as ceilings
 - pipe lagging
 - fire proofing/barriers such as those around structural steel.

HOW TO APPROACH THE SYNOPTIC ASSESSMENT

Task 1a: Produce a labour resource bar chart and materials take-off sheet needed in the planning of the installation

For this task, consider what tasks must be done before others. For example, cables cannot be pulled into conduits before the conduit is installed. If needed, make some assumptions. Try to keep labour resources to a minimum but make sure they are sufficient to keep the progression on time. Below is an example of how this may work but there are several possibilities and right answers. Above all, it needs to be logical.

Task	Days (8 hours per day)														
	1	2	3	4	5	6	7	8	9	10	11	12			
1	Install ceiling lighting conduits														
2	Builders to erect internal stud walls														
3	Install conduit drops for switches														
4	Pull in lighting cables														
5	Builders screed floor														
6	Install dado trunking														
7	Suspended ceiling to be installed														
8	Pull cables into trunking														
9	Fix distribution board (DB)														
10	Terminate DB														
11	Install luminaires														
12	Terminate all luminaires														
13	Install and terminate accessories														
14	Initial verification														
Task needing 1 person		People needed per day													
	Tasks needing 2 people	2	4	2	0	0	0	0	3	4	2	1	1		

The take-off sheet that you produce needs to show all the items on the drawing, a description of what they are and a total of how many.

The sample shown here in the diagram below shows some of the items from the drawing. Note the detail in the description that goes beyond the key of the drawing such as colour, which would match PVC trunking. The number of ways and type of DB included also show understanding.

Symbol	Quantity	Description
	1	Minimum six-way single-phase distribution board with DP switch
	3	14 W ceiling-mounted bulkhead round luminaire white
	11	Two-gang 13 A switched socket outlet white
	2	Ceiling-mounted 6 A pull cord switch

Task 1b: Annotate the drawing to show routes for the PVC conduit runs to supply the ceiling mounted luminaires

As for other tasks, there is no single right answer. Show a logical route and consider how the circuits are to be wired. Once you have decided how they are to be wired, show on your drawing where the conduits will go in the ceiling to supply each light and pick up each switch drop. The plug-in ceiling roses do not need to be directly over each luminaire, just close enough to supply with a flexible cable.

Task 1c: Complete the design criteria within the design grid (circuit lengths are to be estimated using the scaled drawing)

Below is a sample of the completed grid for this installation. Have a look at the values in the blue boxes and see how they have been established. Below the grid is an example of one circuit together with the calculations and assumptions.

Consumer unit located in workshop unit		Nominal voltage (U) 230 V			Earthing Arrangement TN-C-S External earth fault loop impedance (Z_e) 0.3 Ω	
VOLTAGE DROP TO COMPLY WITH BS 7671						
Circuit	1	2	3	4	5	6
Description	Ring-final repairs & plant room	Radial-HVAC	Radial-sockets kitchen \times 3 twin	5.2 kW machine in repairs	Lighting repairs east/centre	Lighting repairs west/kitchen/toilets/HVAC
No. outlets	8 \times 2-gang	1	3 \times 2-gang	1	7	7
Type of wiring	70°C thermoplastic single-core non-sheathed	70°C thermoplastic single-core non-sheathed	70°C thermoplastic single-core non-sheathed	70°C thermoplastic single-core non-sheathed	70°C thermoplastic single-core non-sheathed	70°C thermoplastic single-core non-sheathed
Design current (I_b)	22 A (estimate)	19.6 A	9 A (estimate)	22.6 A	1.52 A	0.7 A
Type and nominal rating (I_n)	32 A B	20 A C	20 A B	25 A C	6 A C	6 A C
Length (metres)	58 m loop	3 m	10 m	9 m	22 m	20 m
Installation method	B	B	B	B	B	B
Ambient temperature °C	25°C	25°C	25°C	30°C	30°C	30°C
Rating factor ambient air temp. C_a	1.03	1.03	1.03	1	1	1
Total circuits in group	2	2	2	1	2	2
Rating factor grouping C_g	0.8	0.8	0.8	1	0.8	0.8
Minimum current capacity ($<I_c$)	24.3	24.3	24.3	25	7.5	7.5
mV/A/m	11(/4)	11	11	11	29	29
Actual voltage drop	3.51	0.64	0.99	2.5	0.97	0.41
Minimum conductor csa mm^2	4	4	4	4	1.5	1.5

Circuit 1 (ring-final circuit)

Information given in the grid-estimated design current (I_b) is 22 A, 32 A Type B circuit breaker, 58 m loop circuit length, meaning this is the length of cable leaving the DB, supplying each socket outlet and returning to the DB. You need to allow for two circuits grouped together.

Because a ring-final circuit cable shares the load through parallel conductors, Regulation 433.1.204 in BS 7671 requires the chosen conductors, after all conditions are taken into account, to have a capacity no less than 20 A.

As the circuit is installed in surface trunking, the reference installation method is B.

As this building has HVAC and is therefore temperature controlled, I am assuming the ambient temperature at the height of the dado to be 25°C and from Table 4B1 in BS 7671, this has a factor of 1.03. From Table 4C1, the factor for two circuits grouped as method B (A–F) is 0.8 so

$$\frac{20}{1.03 \times 0.8} = 24.27 \text{ A}$$

From Table 4D1A of BS 7671, single-phase method B (column 4), a cable that has a tabulated value exceeding this is 4 mm² with a value of 32. The 2.5 mm² cable is quite close to call and so going by the calculation that the minimum exceeds 24 A, this would not be acceptable.

Alternatively, another suitable method to determine the minimum value is to take the value of I_t such as 24 for the 2.5 mm² conductor and apply

$$24 \times 1.03 \times 0.8 = 19.78 \text{ A}$$

As this is less than 20 A as given in Regulation 433.1.204, this is not acceptable so a 4 mm² conductor is selected and

$$32 \times 1.03 \times 0.8 = 26.37 \text{ A}$$

As this is greater than 20 A, this is acceptable.

To calculate the overall voltage drop: the value of mV/A/m for a 4 mm² conductor from Table 4D1B is 11 mV/A/m so voltage drop is

$$\frac{11 \times 22 \times 58}{1000} = 14.04 \text{ but as it is a ring } \frac{14.04}{4} = 3.51 \text{ V}$$

Task 1d: Determine, for circuit 3

- the total earth fault loop impedance (assume the cpc to be one of the cores in the cable)
- the suitability of this cpc for thermal constraints, using the formula contained in Regulation 543.1.3 in BS 7671.

For this task you will need to reference BS 7671 as well as the IET On-Site Guide for this task, and in particular, Table I1 and I3.

- a The live conductors for circuit 3 are wired using single-core cables in trunking, bunched but the csa of the cpc is up to you to choose, as long as it is justified as correct.

For this calculation, we will consider a 2.5 mm² cpc so, using Table I1 and I3, we can calculate the $R_1 + R_2$ based on the circuit length of 10 m.

Looking at Table I1, the value of mΩ/m for a 4/2.5 mm² combination is 12.02 mΩ/m.

Looking at Table I3, the factor for allowing for the increase in resistance due to load is 1.2

$$\frac{12.02 \times 10 \times 1.2}{1000} = 0.14 \Omega$$

So Z_s is $0.3 + 0.14 = 0.44 \Omega$

As the maximum permitted value of Z_s from Table 41.3 for a 20 A Type B circuit breaker is 2.19 Ω and the calculated value of 0.44 Ω is less than this, disconnection under fault conditions will occur in time.

Remember, justification is important and show clear stages to your calculations.

As the total earth fault loop impedance is 0.44 Ω, the fault current will be

$$\frac{230}{0.44} = 522 \text{ A}$$

This means disconnection will occur within 0.1 seconds using Appendix 3 of BS 7671.

Include justification once again.

Looking at Table 54.4 from BS 7671, because the separate cpc is bunched with the live conductors, the value of k is 115.

So

$$s = \frac{\sqrt{522^2 \times 0.1}}{115} = 1.4 \text{ mm}^2$$

As the value from this calculation is 1.4 mm², which is less than the actual cable csa of 2.5 mm² for the cpc, this is suitable as the cable will handle the fault without getting too hot.

Once again, show understanding through justification.

Task 1e: Annotate the drawing showing where self-contained standalone emergency luminaires should be positioned (indicate if maintained)

This task requires you to show on the drawing the positions of self-contained emergency luminaires. These may be maintained or non-maintained.

Remember the golden rules to comply with BS 5266:

- above any exit door and on the outside of final exits
- any change of direction
- any change of level (not applicable to this building)
- any toilet area having no natural light
- providing a minimum of 1 lux of light on designated escape routes
- providing 0.5 lux in open areas.

This is not a public building but a place of work where people are likely to be familiar with this simple building, so maintained lighting is probably not required. If it was provided, it would be suitable over doors as they are lit all the time, or when switched on with other lighting.

Suitable locations for a luminaire include: each toilet, kitchen, above the DB, plant room, over each external door inside and out, one or two in the open repair room area.

Index

- A**
 abstraction licence 43
 AC (alternating current) systems 65
 calculating unknown values 90–7
 capacitance 87–9
 circuits 83–97
 impedance 89–90
 inductance 85–7
 machines 115–23
 transformers 76–7
 accessibility 320–2
 air-source heat pumps (ASHP) 12, 17–20, 35
 alkaline rechargeable batteries 426
 ambient temperature 290
 arc fault detection devices (AFDDs) 136–7, 188
 asbestos, disposal of 444
 Automatic Disconnection of Supply (ADS) 213, 355–6
 average conditions 180
- B**
 backflow prevention 52, 53
 basic insulation 186–7
 bathrooms, as special installations 216–7
 batteries 68, 426–7
 DC battery systems 69
 see also electricity-producing microrenewable energy technologies
 bill of quantities 240
 biomass 20–4, 67
 building regulations 22, 23
 planning permission 23
 blackwater 244
 bonding 182, 215, 356
 equipotential 218
 British Standard finger (IPXXB) 355
 BS 88 fuses 128, 130, 134, 190–1, 194, 286
 BS 1362 plug fuse 128, 191
 BS 3036 rewirable fuses 128, 133–4, 190, 193–4, 209, 286
 BS 7671: 2018 (2022) The IET Wiring Regulations, 18th Edition 10, 16, 402
 Appendices 221–2
 arc fault detection devices (AFDDs) 136–7
 circuit breakers 129, 136
 circuits 280, 291–2
 construction site 249
 electricity 403
 guidance notes 336–7
 how to use 167
 inspection and testing 344, 351–2, 358, 395
 installation instructions 228–9
 legal status 171–2
 methods of installation 292
 numbering system 170–1
 Part 1: scope, object and fundamental principles 172–3
 Part 2: definitions 173
 Part 3: general characteristics 173–9
 Part 4: protection 179–202
 Part 5: selection and erection 202–15
 Part 6: inspection and testing 216
 Part 7: special installations 216–9
 Part 8: functional requirements 219–20
 protective devices 286–8
 structure of 168–70
 understanding 166
 undervoltage 123
 BS 7671 (Construction and demolition site installations) 243
 BS EN 60079-10 429
 BS EN 61558-2-5 79
 building information modelling (BIM) 256
 building regulations 3–4
 accessibility 321
 biomass 22, 23
 chasing 206
 greywater reuse systems 57
 heat pumps 16, 19
 heat-producing microrenewable energy technologies 9–10
 micro-combined heat and power 47
 micro-hydro systems 42
 Part P 336
 rainwater harvesting 52, 53
 solar photovoltaic systems 30
 wind turbines 36
- C**
 cables
 and ambient temperature 290
 bending 208
 clipping regulations 207
 composite 279
 impact protection 207
 sizing 208–9
 cage induction motors 117–8
 calibration 439
 calorific value 21
 capacitance 87–9
 capacitor-start motors 120–1
 capacity, interconnected 66
 carbon dioxide (CO₂) 20–1, 45
 chasing 206
 circuit breakers 128–31, 191–5
 selectivity 211
 see also miniature circuit breakers (MCBs); moulded-case circuit breakers (MCCBs); residual current devices (RCDs)
 circuit protective conductors 304–15, 356
 circuits
 AC (alternating current) systems 83–97
 breaking capacity 285–6
 calculating unknown values 90–7
 capacitance 87–9
 classifications 282
 components in parallel 95–6

- disconnection times 182–3
- distribution 281
- final 281–2
- grouping 291–2
- impedance 89–90
- inductance 85–7, 92
- installation conditions 302
- open circuits 435
- protective devices 284–8
- radial lighting circuits 279–80
- radial power circuits 277–8
- resistance 84
- ring-final circuits 278–9
- RLC series 93–5
- separation of 381–2
- series connected 91–3
- short-circuits 435
- types of 281–2
 - see also* testing
- circulating pump 6
- Class II equipment 185
- Clean Air Act 1956 22
- climate 48
- Climate Change and Sustainable Energy Act 2006 3
- clipping cables 207
- coefficient of performance (COP) 12
- co-generation energy technologies
 - see* micro-combined heat and power
- combined heat and power (CHP) 45, 68
 - see also* micro-combined heat and power
- combustible gases 429
- combustion 429
- commissioning equipment 395
- competence, of workers 254
- composite cable 279
- compound motors 114–5
- conditions, average 180
- conduction 154
- conductor, insulation 289
- conductors
 - continuity of 371–4
 - see also* live conductors
- conduit method 279–80
- conservation areas 23
 - see also* World Heritage Sites
- Construction (Design and Management) Regulations (CDM) 235
- construction site
 - access 255
 - decommissioning systems 252
 - efficiency 256
 - egress 255
 - health and safety 245, 251–6
 - induction training 249
 - materials list 246–7
 - meetings 248
 - pre-existing damage 249–52
 - pre-work survey 249–51
 - protecting property 251–2
 - repair and restoration 262–7
 - site services 242
 - storage facilities 245
 - technical specification 246
 - tidying up 268
 - tools and equipment 247–8
 - ventilation provision 244
 - waste disposal procedures 244
 - waste-water systems 244
 - wholesome water 243
 - work environment 242
 - work programmes 257–60
 - see also* installation
- Construction Skills Certification Scheme (CSCS) 254
- consumer unit (CU) 281, 284–5
- contactors 127, 133
- continuity of conductors 371–4
- contract information 231
- contract law 237
- Control of Asbestos at Work Regulations 2012 444
- convection 153–4
- cosine 100
 - law of illumination 139–42
- critical path 257–60
- current
 - coordination 198–9
 - defining 180
 - excess 435
 - installation 275
 - neutral 105–7
 - three-phase and neutral 105–8
 - see also* AC (alternating current) systems; DC (direct current) systems; overcurrent; transformers
- current transformers 78–9
- customer service 241–2
- D**
- Dangerous Substances and Explosive Atmospheres Regulations 2002 (DSEAR) 428–9
- DC (direct current) systems 69, 111–5
 - generators 111–2
 - motors 113–5
 - transformers 76–7
- dead tests 328, 367, 371
- decommissioning systems,
 - construction site 252
- delivery notes 261
- design
 - of installation 274, 289–315
 - poor 433–4
- differential temperature controller (DTC) 6
- discharge lamps 147–50
- disconnection times 182–3
- distributed generation (DG) 63
- distribution board (DB) 281, 284–5
- distribution circuits 281, 390
- distribution network operators (DNOs) 63–4, 275–6
- domestic voltage 66
- drawings
 - circuit diagrams 234
 - construction/working 236
 - design/tender 235
 - schematic (block) diagrams 231–3
 - sketch 234–5
 - wiring diagrams 233
- duty holder 328, 401
- E**
- earth electrodes 212–3
- earth fault loop impedance

- power supply 75–6
- testing 368–9, 383–6, 388–90
- TN-C-S system 384–5
- TN-S system 383
- TT system 385–6
- earthing 182, 212, 355–6
 - installation 275
 - main earthing terminal (MET) 212
 - TN systems 201
- earthing transformers 80
- efficiency percentage 27
- electric burns 422
- electric shock 181, 421–2
 - protection from 181–8, 353–6
 - risk of 217
- electrical components 126–36
 - see also* fuses; protective devices
- electrical faults *see* fault diagnosis; fault rectification
- electrical fire 422
- Electrical Installation Certificate (EIC) 358, 394–5, 415, 445
- Electrical Installation Condition Report (EICR) 415–7
 - codes 416–20
- electrical separation 185, 355
- electricity, defining 180
- Electricity at Work Regulations (EAWR) 1989 328–9, 332, 403, 405, 421, 434
- Electricity Safety, Quality and Continuity Regulations 2002 336
- electricity supply
 - automatic disconnection of 213, 355–6
 - checking 433
 - construction site 243
 - existing 274–5
 - new installation 276
 - responsibility 276
- electricity-producing microrenewable energy technologies 24–5, 68
 - building regulations 30, 36, 42, 47
 - micro-combined heat and power 44–8
 - micro-hydro systems 37–44
 - planning permission 30, 35–6, 42, 47
 - solar photovoltaic systems 25–31, 68
 - wind turbines 31–7, 68
- electrolyte 68
- electromagnetic interference (EMI) 200, 439
- electronic devices 425
- electronic motor starters 125
- Electrotechnical Certification Scheme (ECS) 254
- emergency switching 202
- enclosures 187–8
- Energy Saving Trust 49
- environment
 - hazardous areas 428–9
 - safe working arrangements 429–30
- environmental site audit (ESA) 43
- equilateral triangle 70–1, 107–8
- equipment
 - calibration 439
 - construction site 247–8
 - faults in 438
 - hand-held 412–3
 - health and safety 410–3
 - installation instructions 228–9
 - misuse of 434
 - product specifications 228
- equipotential bonding 218
- estimate 237, 239–40
- exposed conductive parts 181
- extraneous conductive parts 181
- F**
- fault current 196
- fault diagnosis 405, 410, 414–5, 421–40
- fault protection 355
- fault rectification 440–3
- fibre-optic cabling 424–5
- final circuits 281–2
- final tender 240
- fire, electrical 422
- flammability 429
- flash point 429
- fluorescent tubes, disposal of 444–5
- fossil fuels 20–1, 67
- foundation earth electrodes 212–3
- fuses 127, 190
 - BS 88 fuses 128, 130, 134, 190–1, 194
 - BS 1362 plug fuse 128, 191
 - BS 3036 rewirable fuses 128, 133–4, 190, 193–4, 209
 - circuit breakers 128–31
 - rated short-circuit capacity 130
 - selectivity 210–1
 - fuse-to-fuse selectivity 210–1
- G**
- Gas Safe register 48
- gas supply 172
 - see also* bonding; earthing
- gases
 - and batteries 426
 - combustible 429
 - discharge lamps 147–9
 - resistance 147
 - risks 333
- generators, DC 111–2
- greywater reuse systems 54–8
- grid method, installation design 308–15
- ground-source heat pumps (GSHP) 12–7
- H**
- halogen cycle 146–7
- handover information 268
- hazards
 - chemical 426
 - electronic devices 425
 - fibre-optic cabling 424–5
 - hazardous areas 428–9
 - high-frequency circuits 425
 - information and technology equipment 427–8
 - lone working 423
 - static electricity 423–4
 - storage batteries 426
 - see also* health and safety; risk
- health and safety
 - construction site 245, 251–6
 - fault diagnosis 405

- injuries 412–3
- isolation procedure 329–33, 403–5
- legislation 401–9
- method statement 406–7
- permit to work 407–8
- personal protective equipment (PPE) 413
- recording unsafe situations 413–4
- risk assessment 405–6
- risks 333–4
- tools and equipment 410–3
- use of instruments 410–1
- Health and Safety at Work Act (HSW) 1974 335, 401
- Health and Safety Executive (HSE) 235
 - inspectors 255–6
- heat pumps
 - air source 12, 17–20, 35
 - buffer tank 12–3
 - building regulations 16, 19
 - ground source 12–7
 - microrenewable energy technologies 10–20
 - planning permission 15, 18–9
 - working principles 11, 13–5, 17–8
- heating, underfloor 155
- heating, electrical
 - conduction 154
 - controlling 159–62
 - convection 153–4
 - principles and applications 152–62
 - programmers 161–2
 - radiation 154
 - room thermostats 159
 - space heaters 155–7
 - time switches 161–2
 - water heaters 157–9
- heat-producing microrenewable energy technologies
 - auxiliary heat source 7–8
 - biomass 20
 - building requirements 8
 - heat pumps 10–20
 - hot-water storage cylinder 6–7
 - planning permission 9
 - solar thermal collectors 5, 8–9
 - solar thermal (hot-water) systems 4–10
- high-frequency circuits 425
- high-resistance faults 436
- home medical systems 322
- hot water storage cylinder
 - direct system 7
 - microrenewable energy technologies 6
 - twin-coil 6–7
- hot water systems, electrical 157–9
- hydroelectric energy 67
 - see also* micro-hydro systems
- I**
- ignition, sources of 429
- immersion heater systems 157–8
- impact protection, wiring systems 204–5
- impedance 89–90
- impedance triangles 101
- impoundment licence 43
- improvement notice 255
- incandescent lamps 146
- inductance 85–7, 92
 - transformers 81–2
- induction motors 117–9, 123
- informal warning 255
- information and technology (IT) equipment 427–8
- infrared heaters 157
- initial verification 334–5, 349
- injuries 412–3
- inspection
 - initial verification 334–5
 - periodic 343–8
 - process 350–8
 - schedule of inspections 358–66
 - using human senses 350–1
 - visual 432
- installation
 - cablings 206–9
 - certification documentation 337–42
 - circuits 277–82
 - current 275
 - design 274, 289–315
 - diversity 317–20
 - domestic 274
 - earthing arrangement 275
 - existing supply 274–5
 - failure 435
 - grid method 297–303, 308–15
 - instructions 228–9
 - isolation and control 288, 357–8
 - job specification 229–30
 - lighting circuits 277–80
 - live conductors 274
 - load control 320
 - maximum demand 316–8
 - methods of 292–3
 - nominal voltage 274
 - non-statutory documents 336
 - overload 315–6
 - practical completion 236
 - protective devices 284–8
 - schedule of inspections 358–66
 - schedules 230
 - scope of works 230
 - single-circuit method 293–6
 - special locations 216–9
 - statutory documents 335–6
 - wiring systems 282–8
- instantaneous water heaters 158–9
- insulation
 - basic 186–7
 - conductor 289
 - thermal 290
- insulation resistance tester 368, 425
- interconnected capacity 66
- inverse square law 138–9
- island mode 220
- isolated supply 79
- isolation 201, 210, 288, 357–8
 - procedure 329–33, 403–5
- isolation transformers 79
- J**
- job specification 229–30
- just in time systems 247

- K**
kilovolt-amperes (kVA) 98
kinetic energy 37
- L**
land drainage licence 43
laws of illumination 136
lead-acid batteries 426
lifts 321
light-emitting diode (LED) lamps
 137–8, 151–2
lighting circuits
 installation 277–80
 testing 374–81
lighting systems 137–52
 colour rendering 145
 cosine law 139–42
 discharge lamps 147–50
 efficacy 137, 144–5
 efficiency 137
 faults in 439
 fluorescent lamps 151
 halogen cycle 146–7
 illumination levels 142
 incandescent lamps 146
 inverse square law 138–9
 lamp operation 145–52
 laws of illumination 136
 light-emitting diode (LED) lamps
 137–8, 151–2
 lumen method 142–3
 space-height ratios 144
 terms and units 136
 tungsten filament lamps 146
 tungsten-halogen lamps 146–7
live conductors 274, 297–300
live tests 367
livework 423
load control 320
load profiling 104–5
load shedding 220
Local Authority Building Control
 (LABC) 3
lone working, hazards of 423
lower explosive limit (LEL) 429
low-resistance ohmmeter 368
- M**
machines
 AC 115–23
 DC 111–5
magnetic flux 77
main earthing terminal (MET) 212
Management of Health and Safety at
 Work Regulations 1999 336,
 405, 411
maximum demand 316–8, 349
maximum operating characteristic
 210
mechanical stresses 207
method statement 406–7
micro-combined heat and power
 (mCHP) 44–8
 building regulations 47
 location requirements 46–7
 planning permission 47
microgeneration 3
Microgeneration Certification
 Scheme (MCS) 35, 43
microgeneration technologies 37
micro-hydro systems 37–44
 building regulations 42
 location requirements 41–2
 planning permission 42
microrenewable energy technologies
 see electricity-producing
 microrenewable energy
 technologies
micro-wind *see* wind turbines
mineral-insulated cable 206
miniature circuit breakers (MCBs)
 130, 134–5, 192, 194
Minor Electrical Installations Works
 Certificate (MEIWC) 395,
 415, 445
motors
 AC 115–23
 DC 112–4
 starters 123–5
moulded-case circuit breakers
 (MCCBs) 131, 135, 192, 194
muscle control, loss of 422
- mutual detrimental influence 357
mutual-inductance 82
- N**
National Grid 63–4
National Power 63
negotiated tendering 239
neutral current
 power supply 70, 74
 three-phase and neutral supplies
 105–7
nominal voltage 274, 349
non-statutory documents,
 installation 336
non-statutory regulations 402–3
- O**
obstacles, and basic protection 188
Ohm's law 84–5
open tendering 238
Operation and Maintenance (O&M)
 manuals 236
overcurrent
 protection 189–90, 196–9
 see also circuit breakers
overhead hoist systems 322
overheads 237
overload 315–6
overload current 196
overvoltage 435–6
- P**
panel heaters 157
parallelogram 92–3
periodic inspection 343–8
periodic testing 343–8
permit to work 407–8
permitted development 3
personal protective equipment (PPE)
 413
phase sequence, testing 392
phasor diagram, constructing 92–3,
 94–5, 96
photons 25
photovoltaic energy 25–7
 see also electricity-producing
 microrenewable energy
 technologies

- pipework, labelling 53, 57
 planning
 biomass 23
 greywater reuse systems 57
 heat pumps 15, 18–9
 heat-producing microrenewable energy technologies 9
 micro-combined heat and power 47
 micro-hydro systems 42
 permitted development 2–3
 rainwater harvesting 53
 solar photovoltaic systems 30
 wind turbines 35–6
 plaster, repairing 262–4
 plasterboard, repairing 264
 platform lifts 321
 polarity, testing 382–3
 portable electrical equipment 412–3
 power circuits *see* circuits
 power cut 123
 power factors 101–2
 correction 102–4
 impedance triangles 101
 power generation 63–8
 power ratings, transformers 83
 power stations 63
 power supply 63
 direct current (DC) 69
 earth fault loop impedance 75–6
 load profiling 104–5
 neutral current 70, 74
 single-phase AC 69–70
 source and arrangement of 69–76
 three-phase AC (delta connected) 74–6
 three-phase AC generators 64–6
 three-phase and neutral (star connected) 71–4
 power transformers 78
 power triangle 98
 Powergen 63
 practical completion 236, 268
 pre-arcing 210
 preferred supplier 239
 premature collapse 204
 prescribed zones of protection 206
 prime cost 240
 privatised power system 63
 procurement methods 238–40
 programmers 161–2
 prohibition notice 255
 prosecution 255
 prospective fault current, testing 391–2
 prosumer 105, 220
 protection
 electric shock 180–91, 353–6
 fault 355
 IP codes 353–5
 overcurrent 189–99
 thermal effects 188–9
 undervoltage 200
 protective conductors 212
 protective devices
 checking 433
 faults in 438
 installation 284–8
 see also circuit breakers
 protective earth and neutral (PEN) conductor 201
 protective extra-low voltage (PELV) 185
 protective measures 181–3
 protective multiple earthing (PME) system 215
 Provision and Use of Work Equipment Regulations (PUWER) 1998 247–8, 336
 provisional sum 240
 purchase orders 231, 261
 Pythagoras' theorem 90
Q
 quotation 237
R
 radial circuits, testing 373–5
 radial lighting circuits 279–80
 radial power circuits 277–8
 radiation, heating sources 154
 rainwater harvesting 49–54
 rebars 212
 reduced low-voltage systems 184
 relays 126–7, 132–3
 rescheduling work 260–1
 residual current circuit breakers with overload (RCBOs) 131, 136, 193
 residual current devices (RCDs) 76, 131, 193, 218, 285, 322, 438
 testing 369, 393
 residual hazards 235
 resistance
 AC circuits 84–5
 defining 180
 of gas 147
 and impedance 89–90
 and inductance 90–3
 in motors 119–25
 responsible person 414
 ring-final circuits 278–9
 testing 376–8
 risk
 assessment 405–6
 isolation 333
 RLC series circuits 93–5
 room thermostats 159
 rotor resistance starters 125
 rotor speed 117
S
 safe working arrangements 429–30
 schedule of rates 240
 schedules 230
 see also drawings; installation
 scope of works 230
 selectivity 191, 210
 self-inductance 81–2
 semiconductor 25
 separated extra-low voltage (SELV) 185
 series connected circuits 91–3
 series motors 112–3
 service head (cut out) 275
 shaded-pole motors 121

- shaver sockets 79
- short shipments 247
- short-circuit capacities 130, 199, 286–7
- short-circuits 195–6, 199, 435
- shunt motors 113–4
- signal faults 439
- single-phase AC supply 69–70
 - induction motors 119–20
 - isolation 331
 - machines 115–7
 - TN-C-S system 385
 - TN-S system 384
- slip 117–8
- small works 237–8
- smart homes 162
- smart meter technology 104–5
- smoke-controlled areas 22–3
- soakaways 244
- solar energy 4–6, 67
 - see also* electricity-producing microrenewable energy technologies; heat-producing microrenewable energy technologies
- solar photovoltaic systems 25–31, 68, 320
 - location requirements 28–9
 - planning permission 30
- solar thermal collectors 5, 8–9
- solar thermal (hot-water) systems 4–10
- solenoids 126, 132
- space heaters 155–7
- special locations 216–9
- split-phase induction motors 120
- stair lifts 321
- star-delta starters 124–5
- static electricity 423–4
- statutory documents 335
 - installation 335–6
- statutory instruments 401
- steel conduit 206
- steel-wired armoured cable 206
- step-down transformer 66
- step-up transformer 66
- Stirling engine generator 46
- storage batteries 426–7
- storage facilities, construction site 245
- storage heaters 155–7
- stud walls 206–7
- substations 66
- switching 210
 - emergency 202
 - functional 201–2
- synchronous speed 117
- T**
- take-off sheet 239–40
- temperature, ambient 290
- tender procedure 238–41
- testing 334, 366
 - continuity of conductors 371–4
 - dead tests 328, 367, 371
 - documentation 394–5
 - earth electrode resistance 386–8
 - earth fault loop impedance 383–6, 388–90
 - earth fault loop impedance tester 368–9
 - insulation resistance 368, 378–81
 - interpreting results 440
 - lighting circuits 374–81
 - live tests 367
 - low-resistance ohmmeter 368
 - phase sequence 392
 - polarity 382–3
 - process 371
 - prospective fault current 391–2
 - radial circuits 373–5
 - residual current device (RCD) tester 369
 - residual current devices (RCDs) 393
 - ring-final circuits 376–8
 - test instruments 368–70
 - verification of voltage drop 394
- thermal insulation 290
- three-phase AC (delta connected) 109–11
 - power supply 74–6
 - voltage 109–11
- three-phase AC generators 64–6
 - see also* AC systems
- three-phase and neutral (star connected)
 - neutral current 105–7
 - power supply 71–4
- three-phase isolation 331–2
- three-phase supply
 - TN-C-S system 384–5
 - TN-S system 383
- tiles, repairing 266–8
- time sheets 261
- time switches 161–2
- TN system 183–4
 - earthing 201
- TN-C-S system
 - earth fault loop impedance 384–5
 - single-phase supply 385
 - three-phase supply 384–5
- TN-S system
 - earth fault loop impedance 383
 - single-phase supply 384
 - three-phase supply 384
- tools and equipment *see* equipment
- Town and Country Planning Act 1990 3
- transformers 76–83
 - cores 80
 - emf and number of turns 82–3
 - inductance 81–2
 - laminations 80–1
 - power ratings 83
 - types of 78–80
 - voltage 80
- transient overvoltage 435–6
- true power relationship 98–9
- trunking 206
- TT system 184–5, 212
 - earth fault loop impedance 385–6
- tungsten filament lamps 146
- tungsten halogen lamps 146–7
- two-stage tender 238–9
- U**
- underfloor heating 155
- undervoltage 123, 200

- uninterruptable power supply (UPS)
 - 427–8
- universal motors 121–2
- unsafe situations 413–4
- upper explosive limit (UEL) 429
- user information 229
- V**
- variation order 241, 260–1
- ventilation provision, construction
 - site 244
- voltage
 - batteries 427
 - checking 433
 - components in parallel 95–6
 - and current 98–9
 - current and resistance 84
 - defining 180
 - domestic 66
 - drop 394
 - hazards 425
 - nominal 349
 - power factors 100–4
 - three-phase (delta connected)
 - 109–11
 - three-phase and neutral (star connected) 108–9
- transformers 80
 - see also* undervoltage
- volt-amperes (VA) 98
- W**
- wall tiles, repairing 266–8
- wallpaper, repairing 265–6
- warning signage 330
- waste disposal
 - construction site 244
 - legislation 443–4
- Waste Electrical and Electronic Equipment (WEEE)
 - Regulations 2006 150, 443–4
- waste-water systems, on
 - construction sites 244
- water
 - blackwater 244
 - conservation technologies
 - 48–58
 - greywater reuse systems 54–8
 - micro-hydro systems 37–44
 - rainwater harvesting 49–54
 - wholesome 49, 243
 - see also* hot water systems
- water bowser 243
- Water Supply (Water Fittings)
 - Regulations 1999 53, 55, 57
- wholesome water 49
 - on construction sites 243
- wind turbines 31–7, 67–8
 - building regulations 36
 - location requirements 33–5
 - planning permission 35–6
- wiring systems
 - choice of 202–4
 - external influences 283
 - faults in 436–8
 - impact protection 204–5
 - installation 282–8
 - installation methods 284
- Work at Height Regulations 2005
 - 256
- work programmes, construction site
 - 257–60
- World Heritage Sites
 - air-source heat pumps (ASHP)
 - 19
 - flues 23, 47
- wound rotor induction motors 119
- Z**
- zones of protection 206



The City & Guilds Textbook: Book 2 Electrical Installations, Second Edition Boost eBook

Boost eBooks are interactive, accessible and flexible. They use the latest research and technology to provide the very best experience for students and teachers.

- **Personalise.** Easily navigate the eBook with search, zoom and an image gallery. Make it your own with notes, bookmarks and highlights.
- **Revise.** Select key facts and definitions in the text and save them as flash cards for revision.
- **Listen.** Use text-to-speech to make the content more accessible to students and to improve comprehension and pronunciation.
- **Switch.** Seamlessly move between the printed view for front-of-class teaching and the interactive view for independent study.
- **Download.** Access the eBook offline on any device – in college, at home or on the move – with the Boost eBooks app (available on Android and iOS).

To subscribe or register for a free trial, visit
hoddereducation.co.uk/construction



Book 2

Electrical Installations

SECOND EDITION

LEVEL 3 ELECTROTECHNICAL APPRENTICESHIP (5357)
LEVEL 3 ELECTROTECHNICAL IN DWELLINGS APPRENTICESHIP (5393)
LEVEL 3 ADVANCED TECHNICAL DIPLOMA (8202)
LEVEL 3 DIPLOMA (2365)
T LEVEL OCCUPATIONAL SPECIALISMS (352/353)

Peter Tanner

Equip yourself with the tools for success in **Electrical Installations** with this comprehensive and updated edition of the bestselling textbook, published in association with City & Guilds and IET.

- Study with confidence using the most up-to-date information available for the new industry standards, including the 2022 amendments to BS7671: 2018, The IET Wiring Regulations 18th Edition.
- Enhance your understanding of concepts in electrical installation with hundreds of clear and accurate technical drawings and step-by-step photo sequences.
- Practise maths and English in context, with embedded 'Improve your maths' and 'Improve your English' activities.
- Get ready for the workplace with industry tips.
- Prepare for your trade tests or end-of-year exams with end-of-chapter practice questions and end-of-book synoptic assignments.
- Engage with author Peter Tanner's accessible text, drawing on his extensive industry experience.
- Target your learning with detailed qualification mapping grids for the latest City & Guilds Level 2 qualifications – including the 2365, 8202, 5357 and 5393 specifications, as well as the 352 and 353 T Level occupational specialisms.



Boost

This title is also available as an eBook with learning support.

Visit hoddereducation.co.uk/boost to find out more.

HODDER EDUCATION

t: 01235 827827

e: education@hachette.co.uk

w: hoddereducation.co.uk

Schools have a Licence to Copy
one chapter or 5% for teaching



CLA Copyright
Licensing Agency

ISBN 978-1-3983-6160-7

